

Instructions for SLO-SYN[®] MICRO SERIES Translator Oscillator Modules Types 230-TOH and 430-TOH

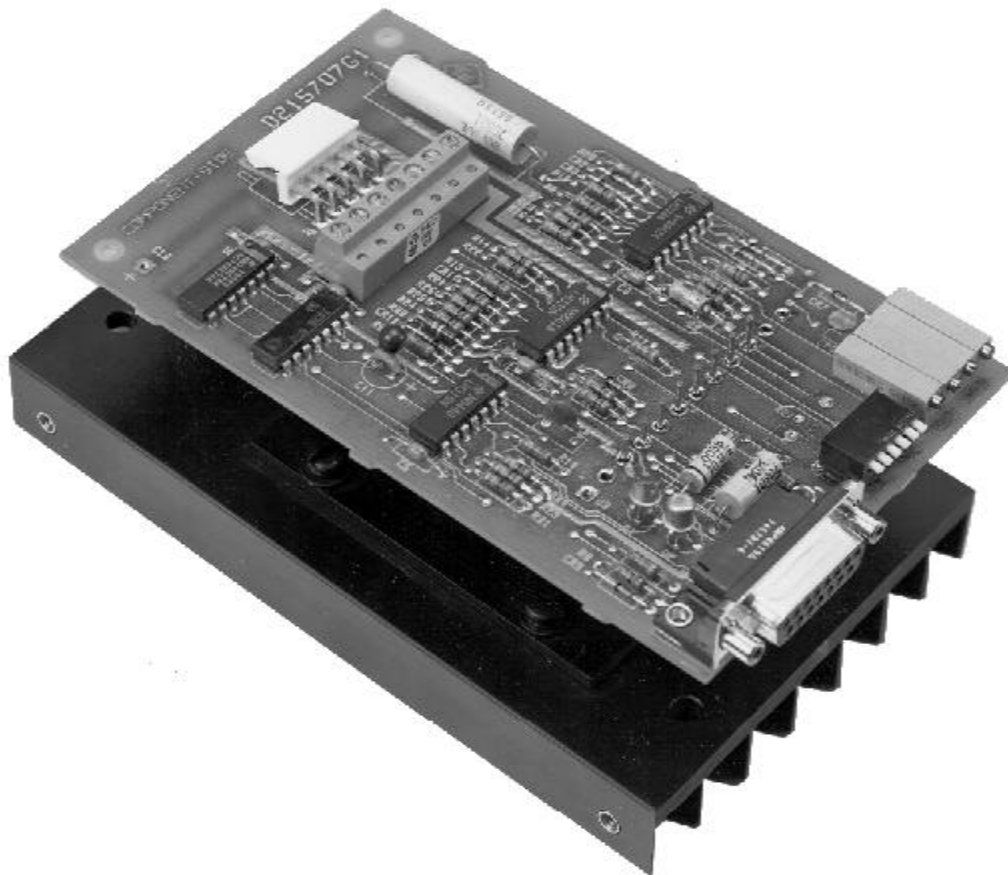

Superior
Electric

EXPRESS START-UP PROCEDURE

STEPS NECESSARY TO BECOME OPERATIONAL

This section outlines the minimum steps necessary for the unit to become operational. **FAILURE TO PERFORM THESE STEPS MAY RESULT IN DAMAGE TO THE DRIVE.**

I. POWER SUPPLIES

Be absolutely certain that the power supplied to the Translator/Oscillator meets the following specifications:

Supply Type	Nominal Voltage	Voltage Range (Worst Case)	Current (Amperes)	Connector J2 Pin Number
Logic	+5 Vdc	+4.75 to +5.25 Vdc (without SSP-500)	0.6*	2
		+5.00 to +5.25 (with SSP-500)	0.9*	2
Digital	+15 Vdc	+12 to +16 Vdc	0.030	1
Logic Common	—	—	—	3
Motor (Vm)	+28 Vdc	+26 to +32 Vdc	2.5 (230 drive)	4
			4.0 (430 drive)	4
Motor Supply Common	—	—	—	5

* Current Level is Logic board (Translator/Oscillator, Indexer) dependent.

The Power Supply peak ripple voltages must not go higher than 32 volts or lower than 26 volts.

POWER CONNECTOR (mates with J2 on printed circuit board)
Superior Electric part number B209270-003
AMP part number 640599-5

MOTOR CONNECTOR (mates with J4 on printed circuit board)
Superior Electric part number B215744-007
Electrovert part number 25.600.0753

NOTE: These parts are supplied in the accessory kit provided with your unit.

**RECOMMENDED 24Vdc MOTOR POWER SUPPLY
230/430T DRIVES**

"Generic" Configuration --

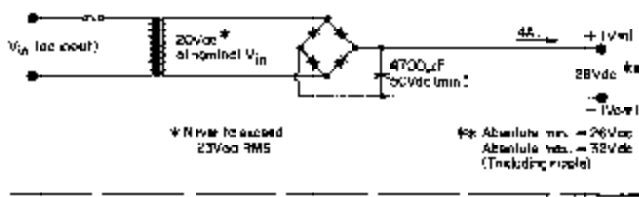

Actual Configuration for 115Vac operation --

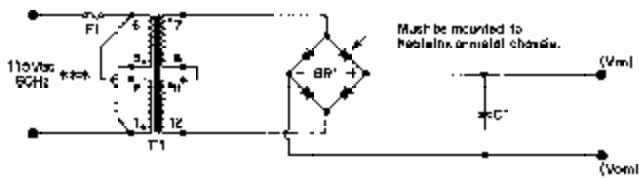

PARTS LIST

ITEM	TYPE	RATING	TYPICAL MFR. & PART NO.
F1	FUSE	1A., 250V. SLOW-BLOW	BUSSEMAN MDA-3
T1	TRANSFORMER	30VA, 115/230V PRIM, 20V CT, SECONDARY	SIGNAL 24"-10"-20
BR	RECTIFYING BRIDGE	30A., 200V	VARO VKE24B
C1	ELECTROLYTIC CAPACITOR	4700µF, 50Vdc 5.53A RMS	SPRAGUE 58D-12606-0114

For 230Vac, 50Hz operation, connect
*** T1 primary windings in series
(Rest of the circuit remains the same)

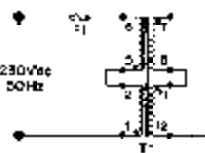

**RECOMMENDED POWER SUPPLY CONFIGURATIONS
SINGLE UNIT APPLICATIONS
FIGURE 1**

**RECOMMENDED POWER SUPPLY CONFIGURATIONS
FOR 230/430T
MULTIPLE DRIVES ON ONE SUPPLY**

OBJECTIVE: Eliminate stepping of reference voltage to multiple drives.

NOTE: --

1) Using Diode Isolation --

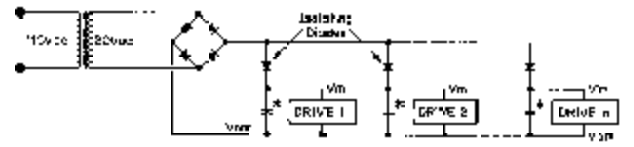

2) Using separate Transformer Windings --

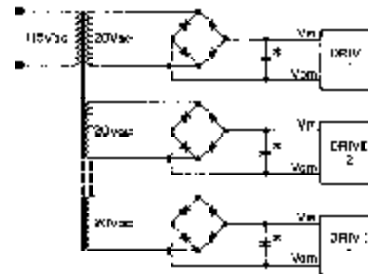

3) Using separate Bridge Rectifiers --

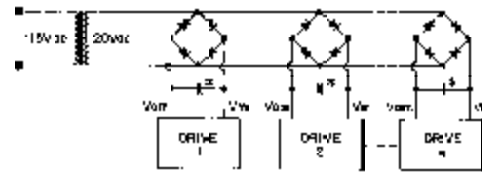

* All filter capacitors are 4700µF, 50Vdc (min.)

**RECOMMENDED POWER SUPPLY CONFIGURATIONS
MULTIPLE UNITS FROM ONE POWER SUPPLY
FIGURE 2**

II. DRIVE

1. Make sure the motor to be used is compatible with the drive. Refer to the Section 3.3 for a list of compatible motors.
2. Use the motor connection diagrams shown in section 2.2 for connection 4-, 6- or 8-lead motors. When using a 6-lead motor, be sure to insulate and isolate the unused motor leads to prevent inadvertent shorts to ground or to each other.
3. Install a resistor of appropriate value between the REDUCE CURRENT- pin and the LOGIC COMMON pin. Refer to the speed versus torque data in section 4 and the resistor versus current table in Section 3.7. If you desire to run the REDUCE CURRENT- manually, refer to the circuit shown in Figure 3.
4. Caution: The Drive Module case is connected to the Vom and LOGIC COMMON pins internally. Do not connect your power supply to ground at any other location.
5. Caution: Erratic operation may occur at speeds less than 350 steps per second due to motor resonance. Avoid this speed range if a problem exists.

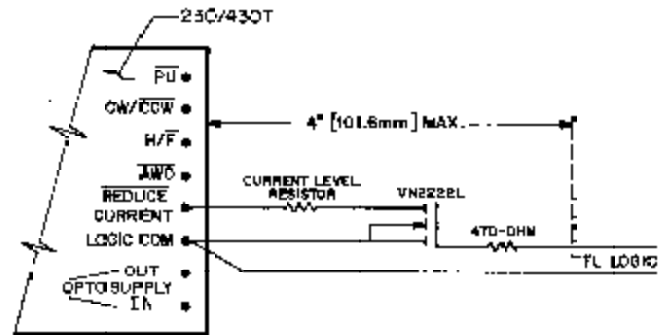

NOTES: --

1. - A "HIGH" level TTL signal on the input activates REDUCE CURRENT.
2. - Keep the FET and current level resistor within four inches of the Module.
3. - Refer to the manual for current level resistor values.

**TYPICAL REDUCED CURRENT INTERFACE
FIGURE 3**

INSTALLATION GUIDELINES FOR REDUCED NOISE INTERFERENCE

I. General Comments

SLO-SYN Micro Series drives use modern solid-state electronics such as microprocessors to provide the features needed for advanced motion control applications. In some cases, these applications produce electromagnetic interference (EMI, or electrical "noise") that may cause inappropriate operation of the microprocessor logic used in the Micro Series product, or in any other computer-type equipment in the user's system.

This guide is aimed toward helping users avoid such problems at the start by applying "good engineering practices" when designing their systems. Following these guidelines will usually prevent EMI noise from interfering with drive operation.

II. Noise Sources

What causes electrical noise? In general, any equipment that causes arcs or sparks or that switches voltage or current at high frequencies can cause interference. In addition, ac utility lines are often "polluted" with electrical noise from sources outside a user's control (such as equipment in the factory next door).

The following are some of the more common causes of electrical interference:

- power from the utility ac line
- relays, contactors and solenoids
- light dimmers
- arc welders
- motors and motor starters
- induction heaters
- radio controls or transmitters
- switch-mode power supplies
- computer-based equipment
- high frequency lighting equipment
- dc servo and stepper motors and drives

III. Mounting Location

When selecting a mounting location, it is preferable to keep the drive away from obvious noise sources, such as those listed above. If possible, locate the drive in its own metal enclosure to shield it and its wiring from noise sources. If this cannot be done, keep the drive at least three feet from any noise sources.

IV. Wiring Practices - "Dos and Don'ts"

Do the following when installing or wiring your drive or indexer:

- **Do** keep the drive and its wiring as far away; from noise sources as possible
- **Do** provide a good, solid ground connection to the ac system earth ground conductor. Bond the drive case to the system enclosure.
- **Do** use a single-point grounding scheme for all related components of a system (this looks like a "hub and spokes" arrangement).
- **Do** keep the ground connection short and direct.

- **Do** use a line filter on the ac input (Corcom type 10B1, 10S1 or 10K1 or equivalent) for noisy ac lines. Particularly bad ac lines may need to be conditioned with a ferroresonant type isolation transformer to provide "clean" power to the drive or indexer.
- **Do** keep signal and drive wiring well separated. If the wires must cross, they should do so at right angles to minimize coupling. Power wiring includes ac wiring, motor wiring, etc. and signal wiring includes inputs and outputs (I/O), serial communications (RS232 lines), etc.
- **Do** use separate conduits or ducts for signal and I/O wiring. Keep all power wiring out of these signal line conduits.
- **Do** use shielded, twisted-pair cables for indexer I/O lines.
- **Do** ground shields only at one end, the indexer/drive end.
- **Do** use twisted-pair, shielded cable for the motor wiring.
- **Do** use solid-state relays instead of electromechanical contact types wherever possible to minimize noise generation.
- **Do** suppress all relays to prevent noise generation. Typical suppressors are capacitors or MOV's. See manufacturers literature for complete information.
- **Do** use shielded, twisted-pair cable for connection to RS232 serial port.

Do Not do the following when installing your drive or indexer:

- **Do not** install sensitive computer-based equipment (such as an indexer/drive) near a source of electromagnetic noise.
- **Do not** bundle power and signal lines together.
- **Do not** bundle motor cables and signal lines together.
- **Do not** fail to use shielded, twisted-pair cables for signals.
- **Do not** fail to properly connect the system grounds.
- **Do not** use "daisy-chained" grounds.
- **Do not** fail to ground signal cable shields at only one end.
- **Do not** assume that power from the ac line is adequately "clean".

V Troubleshooting Guide

Electrical interference problems are common with today's computer-based controls, and such problems are often difficult to diagnose and cure. If such a problem occurs with your system, it is recommended that the following checks be made to locate the cause of the problem.

1. Check the quality of the ac line voltage using an oscilloscope and a line monitor, such as Superior Electric's VMS series. If line voltage problems exist, use appropriate line conditioning, such as line filters or isolation transformers.
2. Be certain all of the previous Dos and Don'ts are followed for location, grounding, wiring and relay suppression.
3. Double check the grounding connections to be sure they are good electrical connections and are as short and direct as possible.
4. Try operating the drive with all suspected noise sources switched off. If the drive functions properly, switch the noise sources on again, one at a time, and try to isolate which ones are causing the interference problems. When a noise source is located, try rerouting wiring, suppressing relays or other measures to eliminate the problem.

Recommended Wiring Practices

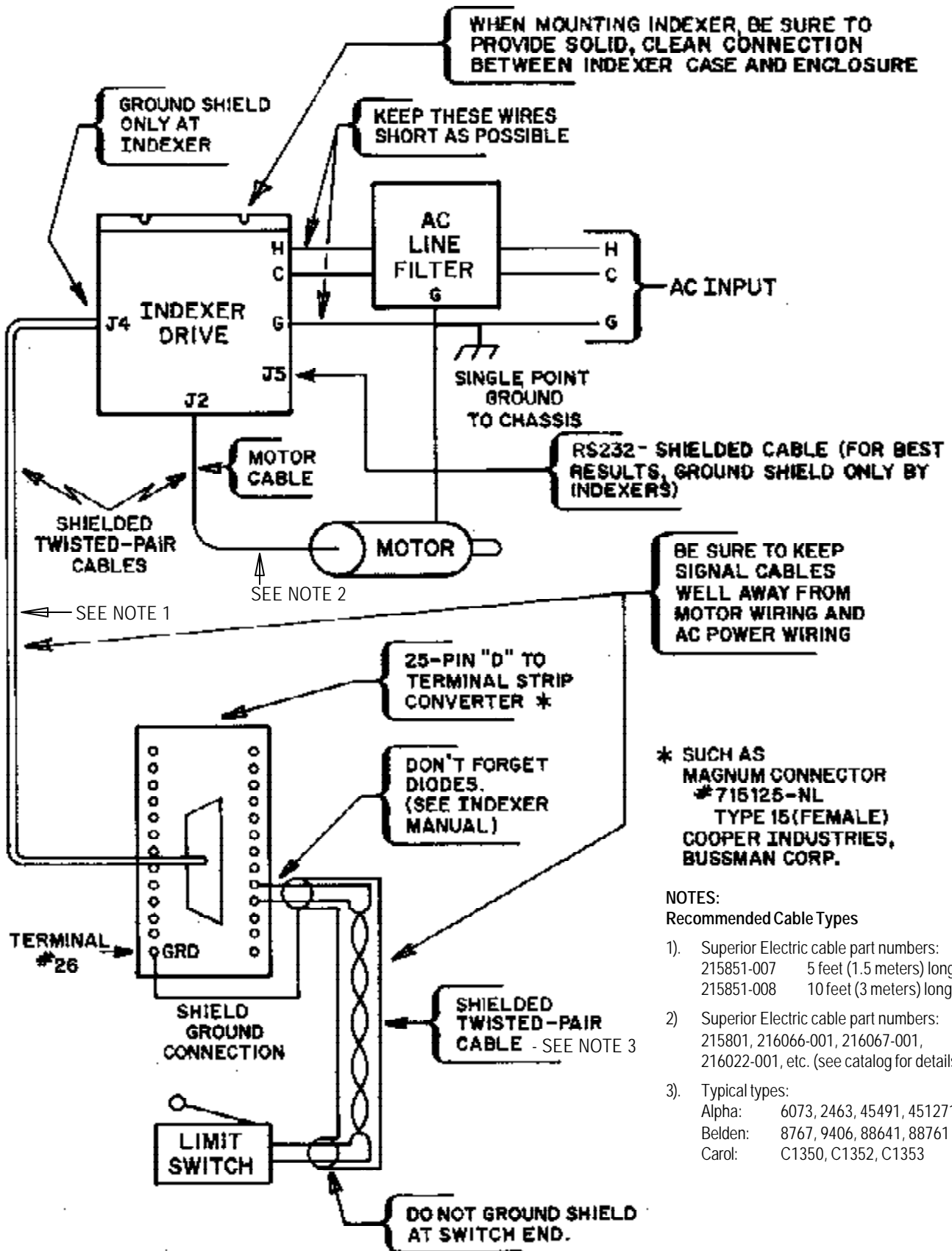

WARNINGS

- Voltage is present on unprotected pins when unit is operational.
- No short circuit protection is provided in this unit.

LIMITS OF USE

- Superior Electric disclaims any liability for operating this unit without the correct filter capacitor.
- Assure motor compatibility before using the unit.
- Case temperature must be maintained between 0 and 75 degrees C. (32 and 167 degrees F).
- Reconfiguration of the circuit in any fashion not shown in this manual will void the warranty.

- All Windings Off should be used with caution, as all holding torque is lost.

NOTES:

1. Clockwise and counterclockwise directions are properly oriented when viewing the motor from the *lable end*.
2. Motor connector, J4, consists of 7 pins arranged symmetrically around the center pin. If the connector is inadvertently rotated 180 degrees, motor direction (CW, CCW) will be reversed. Motor direction can also be reversed by swapping the two motor connections of the *same phase* (for example, by swapping M1 and M3).

SECTION 1: INTRODUCTION

1.1 FEATURES OVERVIEW

The 230-TOH and 430-TOH are differentiated as follows:

	MOTOR CURRENT PER PHASE	VA PER PHASE
230-TOH	2 Amps peak	56 VA nominal
430-TOH	3.5 Amps peak	96 VA nominal

The 230-TOH and the 430-TOH are low-cost pulse generators that are integrally packaged with a motor drive unit and a heat sink. These translators are low to medium power, high efficiency units that can control a wide range of Superior Electric SLO-SYN two-phase stepping motors with 4, 6 or 8 leads. These modules provide full-and half-step operation.

The translator modules are designed as small, easily mounted packages and allow for the external control of basic motor functions as well as the manual adjustment of motor speed, acceleration and deceleration.

1.2 INSPECTION PARTS LIST

The drive module, oscillator, and heat sink come fully assembled as a single unit and are marked with the part number, either 230-TOH or 430-TOH.

The terminal strip that is used to connect the motor leads to the Oscillator/Driver unit is packaged separately, and is identified as Superior Electric part # B215744-007.

1.3 USING THIS MANUAL

This manual is an installation and operating guide to the 230-TOH and 430-TOH modules. All the information provided is necessary for using these modules successfully.

We strongly recommend that this manual be read thoroughly and completely before attempting to install and operate the equipment.

1.3.1 Organization

All entries in this manual refer to both the 230-TOH and the 430-TOH modules, unless otherwise specified.

This manual is organized for the convenience of the operator. Section 2, "Mounting and Pin Assignments," provides diagrams and reminders that are necessary, even for the experienced user and installer.

Complete specifications (Section 3) will provide easily referenced information concerning all aspects of installation, power and interface requirements, as well as performance specifications.

The "Functional Description" (Section 4) provides operational information in narrative form. This presentation is useful in design, diagnostic, and troubleshooting.

Section 5, "Pin Descriptions," provides detailed information on functions of the input connections in advance of using the equipment.

Section 6, "Operating Instructions," lists the procedures for using a remote potentiometer, setting base speed and high speed and the acceleration and deceleration potentiometers.

The following sections contain additional drawings and information useful for setting up and operating the oscillator modules.

1.3.2 LOGIC and VOLTAGE CONVENTIONS

Throughout this manual, the following conventions are followed:

- The designation "Vo" signifies the logic signal common terminal. "Vom" signifies the motor supply voltage common terminal. Vom is internally connected to the drive module's aluminum case.
- All logic functions are *low true logic*. A logic low or logic 0 will activate a function and a logic high, or a logic 1 will deactivate a function. Thus,

IN THIS MANUAL THE TERMS ACTIVE OR ACTIVATE WILL IMPLY A LOGIC LOW CONDITION AND THE TERMS INACTIVE OR DEACTIVATE WILL IMPLY A LOGIC HIGH CONDITION.

- In cases where the function changes with a change in logic state,

the low true (active) will be indicated with a bar. For example, in the case of CW/CCW, CW is active with no connection.

- All logic control pins are optically isolated internally. When a pin is left *open*, it is clamped in a **logic high** (inactivated) state.
- The motor drive changes state and advances the motor one step (or on-half step in the half-step mode) on a positive going (low to high) pulse edge.
- Clockwise (CW) and counterclockwise (CCW) are oriented correctly when viewing the motor from the label end.

SECTION 2: MOUNTING AND PIN ASSIGNMENTS

2.1 MOUNTING

The 230-TOH and 430-TOH modules are mounted by affixing the heat sink to a flat surface. Figure 2.1 shows the mounting hole locations and diameters. It is recommended that 6-32 or 8-32 screws be used for mounting.

The major mounting consideration is that the aluminum case temperature be maintained below 167°F (75°C).

The heat sink should always be mounted with the fins oriented vertically, or proper cooling will not occur.

If the heat sink is separated from the motor drive module for mounting on opposite sides of a bulkhead, silicone heat sink compound (such as Dow-Corning 340) should always be used during reassembly. A very thin coating is sufficient; too much is worse than none at all. Aluminum is the preferred bulkhead material if this reconfiguration is done.

2.2 MOTOR CONNECTIONS

All motor connections are made via 7 pins on the oscillator board. The terminal strip supplied by Superior Electric (Part # B215744-007) is the recommended mounting method. Figure 2.2 shows the location and function of the motor drive pins.

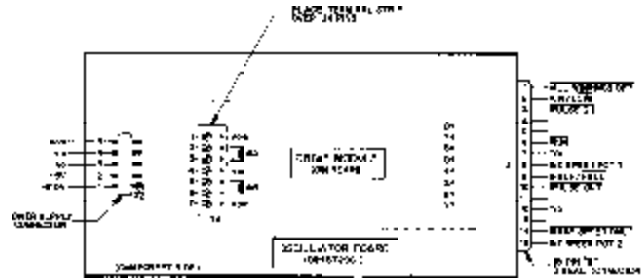

Figure 2.2
Motor and I/O Signal Pin Connections

It is suggested that a Superior Electric motor cable be used. They are available as follows:

LENGTH	NO TERMINALS PART NUMBER	WITH MATING TERMINAL FOR SUPERIOR ELECTRIC CONNECTOR MOTORS PART NUMBER
10 ft (3m)	B216022-001	B216067-001
20 ft (7.6m)	B216022-002	B216067-002
50 ft (15.2m)	B216022-003	B216067-003

PLEASE NOTE: The motor drive pins are arranged symmetrically about the center Vm pin. When connecting the motor, if the motor connector is inadvertently rotated 180 degrees, then the CW and CCW directions will be reversed. See Figure 2.2

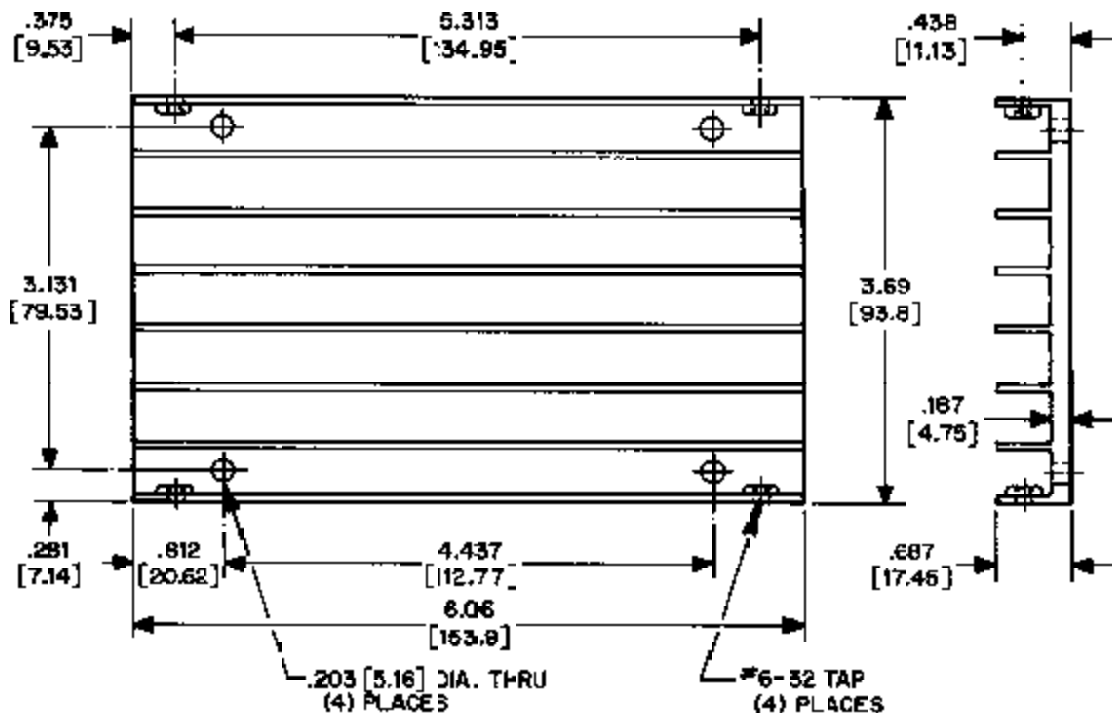
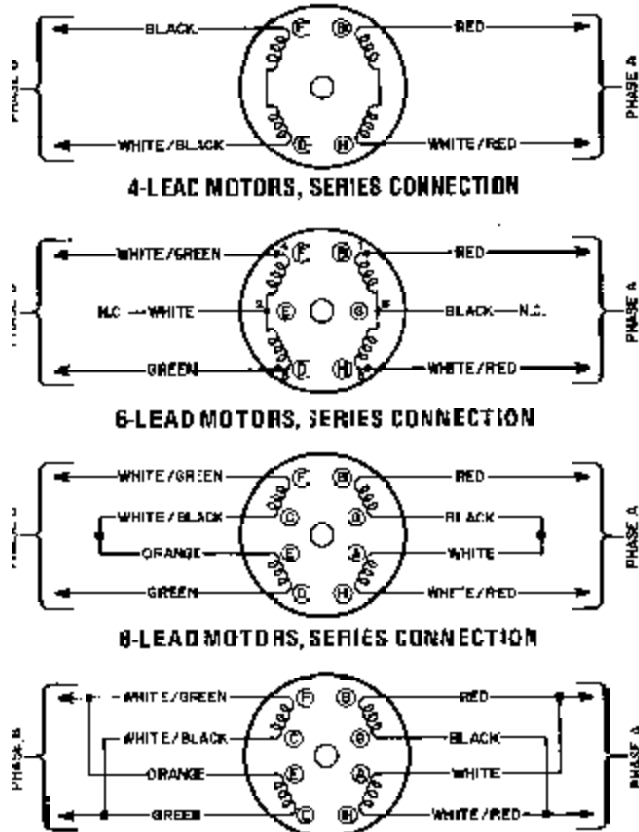

Figure 2.1: Mounting Diagram

The 230-TOH and 430-TOH can be used with 4-lead, 6-lead and 8-lead SLO-SYN motors. Figure 2.2 shows the correct connections for each possible motor configuration.



MOTOR CONNECTIONS, FIGURE 2.3

SECTION 3: SPECIFICATIONS

3.1 PRODUCT DESCRIPTION

Bipolar, speed adjustable, 2-phase stepping motor drive with translator and oscillator

Full and half step only

Power semiconductor type: H-bridge power IC

Translator: Internal IC

Control signals are optically isolated from the motor drive module (except for Reduce Current)

Power supplies are necessary: (see Section 3.5.1.1)

3.2 PERFORMANCE

Resolution: Half-step or full-step

Step Rate: 0 to 10,000 full-steps/sec.;
0 to 10,000 half-steps/sec.

Oscillator base speed frequency range: 0 Hz to 2500 Hz

(BASE SPEED ONLY connected to SIGNAL COMMON)

Oscillator high speed frequency range 0 HZ to 25k HZ

(HI SPEED POT 1 and 2 connected; Adjustment with user-supplied 500 k ohm HI SPEED POT)

Accel/Decel adjustable range:

50ms to 2 sec.

Oscillator stability: Velocity; Accel/Decel \pm 5% over temperature and power supply range.

Speed/Torque: All specifications uses typical data.

See Section 7 for typical Speed/Torque curves.

Drive power dissipation (worst case)

230-TOH: 25 watts

430-TOH: 40 watts

3.3 MOTOR COMPATIBILITY

	<u>230-TOH</u>	<u>430-TOH</u>
Frame Sizes:	M061 to M092	M063 to M112
No. of Leads:	4, 6, 8	4, 6, 8
Min. Inductance		0.55 MH
Max. Resistance	3.5 ohms including drive-to-motor cable	

CAUTION: DO NOT USE LARGER FRAME SIZE MOTOR THAN THOSE LISTED, OR THE DRIVE MAY BE DAMAGED.

MOTOR FAMILIES

MOTORS FOR USE WITH 230-TOH

WITH CONNECTOR

M061-CS08	M062-CS09	M063-CS06
M061-CE08	M062-CE09	M063-CS09
		M063-CE09

WITH LEADS

M061-LS08	M063-LE09	M092-FD09
M061-LE08	M091-FC09	M092-FD310
M062-LS09	M091-FD09	M092-FD8009
M062-LE09	M091-FD8009	M092-FD8109
M063-LS06	M091-FD8109	M092-FD8814
M063-LS09	M092-FC09	

MOTORS FOR USE WITH 430-TOH

WITH CONNECTOR

M061-CS08	M062-CE09	M063-CS09
M061-CE08	M063-CS06	M063-CE09
M062-CS09	M063-CE06	

WITH LEADS

M061-LS08	M091-FD06	M093-FD8011
M061-LE08	M091-FD8106	M093-FD8014
M062-LS09	M092-FC09	M111-FD12
M062-LE09	M092-FD09	M111-FD16
M063-LS06	M092-FD310	M111-FD8012
M063-LE06	M092-FD8009	M112-FD327
M063-LS09	M092-FD8109	M112-FD8012
M063-LE09	M093-FC14	M112-FJ8012
M091-FC06	M093-FD14	M112-FJ8030

Table 3.1: Motor Families

3.4 MECHANICAL SPECIFICATIONS

Size (inches/mm): 3.7"D x 6.3"W x 2.25"H
(94mm D x 160mm W x 57mm H)

Weight (lbs/kg): 230-TOH: 1.5 (0.68 kg)
430-TOH: 2.0 (0.91 kg)

3.5 ELECTRICAL SPECIFICATIONS

3.5.1 INPUT POWER SUPPLY

3.5.1.1 Power and Voltages

Power Supply Requirements

Logic Voltage: +15 VDC
Range: +12.5 VDC to +17.5 VDC
Current: 40 milliamps max.
Digital Voltage: +5 VDC
Range: +4.75 VDC to +5.25 VDC
Current: 100 milliamps max.

NOTE: Logic and digital voltage power supplies should be isolated from the motor power supply.

Motor Supply Voltage: 28 VDC nominal, 24 min. to 36 max.
including ripple

Motor Supply Current: 230-TOH 2.5 Amperes
430-TOH 4.0 Amperes

NOTE: Operation from a 28-30 VDC supply gives the best overall performance, considering trade-offs of motor and drive heating power supply current and torque vs. speed.

3.5.1.2 Connections

Method: 5 Pin MTA type connector (e.g., AMP P/N 640599-5)

Assignment: J2

Pin	Assignment
1	+15V
2	+5
3	Vo (signal common)
4	Vm (motor supply positive terminal)
5	Vom (motor supply negative terminal)

Vom and Vo are internally connected to the module's aluminum case.

Cable Size: 14 gauge max.

Cable Length: 20 ft (6.1m) max., twisted

3.5.2 OUTPUT TO MOTOR

3.5.2.1 Motor Connections

Assignment: J4: 7 pins on oscillator board (See Figure 2.2)

Pin	Assignment
1	Vom — INTERNAL CONNECTION — DO NOT USE
2	M1
3	M3
4	VM — INTERNAL CONNECTION — DO NOT USE
5	M4
6	M5
7	Vom — INTERNAL CONNECTION — DO NOT USE

NOTE: The motor supply voltage connections are made internally between J-2 and the Vm and Vom pins on connector J4. Vom is connected internally to the aluminum case of the drive module.

Method: Pins or terminal block (Part #B215744-007).

Assignment: Vm = +, Vom = Common

Cable Size: 14 Gauge max., when using terminal block. Superior Electric cables are recommended; see Section 2.2 for part numbers.

3.6 I/O (Interface)

3.6.1 I/O Connector: J1: 15 pin, "D" type female.
(see Figure 2.2)

Pin Assignments:

Pin #	Assignment
1	ALL WINDINGS OFF
2	CW/CCW
3	PULSE IN
4	DO NOT USE
5	DO NOT USE
6	RUN
7	Vo (signal common)
8	HI SPEED POT 1
9	HALF/FULL
10	PULSE OUT
11	DO NOT USE
12	Vo (signal common)
13	DO NOT USE
14	BASE SPEED ONLY
15	HI SPEED POT 2

NOTE: The bar denotes low logic, active state

Wire Size: 28 AWG minimum
Run Length: 50 feet (15 meters) max.; 15 feet (4.6 meters) max. for HI SPEED POT 1 and HI SPEED POT 2.
Shielded cable must be used for highest noise immunity. Be sure to ground the shield only at one end of the cable.

3.6.2 Potentiometers (see Figure 9.0 for potentiometer locations)

R1 Deceleration	R3 High Speed
R2 Acceleration	R4 Base Speed

3.6.3 I/O Characteristics

<u>RUN, BASE SPEED ONLY</u> (Input Characteristics)	
High Voltage Level	+5.5 VDC to +15 VDC
High Level Current	600 microamperes max.
Low Level Voltage	0 VDC to +4.5 VDC
Low Level Current	1.8 milliamperes max.

<u>AWO, CW/CCW, PULSE IN, HALF/FULL</u> (Input Characteristics)	
High Level Input Sinking Current	less than 1 milliampere
Low Level Input Sinking Current	10 to 20 milliamperes

NOTE: These inputs are tied to Signal Common (7, 12) for a low level input and open collectored for the high input level.

<u>PULSE OUT</u> Output Characteristics	
High Level Output Characteristics	+24 VDC
Low Level Output Voltage	+0.7 VDC max. at 40 milliamperes max.

3.7 ENVIRONMENTAL REQUIREMENTS

Storage Temp:	-40°F to +185°F (-40°C to +85°C)
Operating Temp:	
Drive Module:	+32°F to +167°F (0°C to +75°C) on case
Oscillator:	+32°F to +122°F (0°C to +50°C) free air ambient
Humidity:	95% max., noncondensing
Altitude:	10,000 feet (3048 meters) max.
Thermal Requirements:	Maintain drive module case temperature below 167°F (75°C)

NOTE: The drive module will operate within its temperature limit if heat sink fins are vertical and free air ambient is within the specified limits.

SECTION 4: FUNCTIONAL DESCRIPTION

4.1 OVERVIEW

The 230-TOH and 430-TOH are motor drive/translator/pulse generator modules that allow for the operation of all basic motor functions.

External power to the unit is required.

The functions that the module performs are:

- Adjustable acceleration and deceleration
- Adjustable base speed
- Clockwise/counterclockwise direction control
- Full-step/half-step control
- Run-stop control
- Remote mechanical speed adjustment

4.2 Operational description

The 230-TOH and 430-TOH modules can be functionally divided into four components:

1. Motor drive circuitry
2. Translator circuitry
3. Oscillator/pulse generator circuits
4. Logic control functions

To drive the motor, a technique called "chopping" is used. Compared to older drive techniques, chopping gives improved motor performance while allowing the drive circuitry to dissipate less power. The voltage applied to the motor windings is turned on and off very rapidly, or **chopped**, so that the desired current is produced.

The translator circuitry accepts a single pulse as an input and determines which windings (phases) of the motor must be turned on and off in order to advance the motor shaft one step, in the full-step mode. The translator circuit is fully self-contained and is not accessible through any of the function pins.

The pulse input to the translator is internally generated by the oscillator. **This is accomplished by setting switch S1, position 4 to the "on" (closed) state, unless an external pulse source is utilized.** The oscillator circuitry controls the frequency of the pulse train for acceleration, deceleration, high and base speeds in accordance with the settings of potentiometers R1 thru R4.

The logic control circuitry accepts high or low logic levels through the pins on connector J1 and adjusts the motor operational parameters as described in Section 5.

The 230-TOH and 430-TOH enable the user to remotely control the high speed rate by connecting a 500 k ohm potentiometer between pins 8 & 15 on connector J1. **If no external potentiometer is required, set position 3 of switch S1 to the "on" (closed) state.**

SECTION 5: PIN CONNECTIONS

(Reference Figure 2.2)

Connector J1, 15-pin "D" type connector, female

5.1 AWO (ALL WINDINGS OFF) - Pin 1

When connected to SIGNAL COMMON (closed), i.e., when activated, turns off all power to the motor windings. The motor shaft can now be turned by hand. No motion can occur if this signal is active.

When this pin is left open, all windings are on.

WARNING:

Holding torque is eliminated when this signal is active. Ensure that the motor load, when released by this command, will not injure property or personnel.

5.2 CW/CCW (DIRECTION) - Pin 2

A logical high causes the motor shaft to step in the clockwise direction as viewed from the label end of the motor. A logical low, or connection to LOGIC COMMON results in counterclockwise direction. With this pin left open, the motor will step in a CW direction.

5.3 \overline{PU} (PULSE IN) - Pin 3

A low to high transition (positive going edge) on this pin causes the motor to take one step in the direction selected by the CW/CCW pin.

Normally, when the oscillator board is used for control, this pin is connected to $\overline{PULSE\ OUT}$, pin #10, by placing position 4 of switch S1 in the "on" (closed) state.

Minimum pulse width low is 15 microseconds; minimum pulse width high is 50 microseconds.

5.4 DO NOT USE - Pin 4

This pin is not available to the operator

5.5 DO NOT USE - Pin 5

This pin is not available to the operator

5.6 \overline{RUN} - Pin 6

When connected to "Signal Common" (logic low), enables the oscillator.

If BASE SPEED ONLY is open (logic high) when RUN is activated, the motor will accelerate according to the set rate, to the predetermined high speed. When RUN is open (logic high), the motor will decelerate according to the set rate until base speed is reached and will then stop.

If BASE SPEED ONLY is activated (logic low) when RUN is activated (logic low), the motor will run at base speed until RUN is open (logic high).

5.7 LOGIC COMMON (Vo) - Pin 7

Reference point for inputs and outputs.

5.8 HI SPEED POT 1 - Pin 8

Allows for control of high speed by means of an external 500k ohm potentiometer, when used in conjunction with HI SPEED POT 2 (pin #15).

This is also a test point for acceleration and deceleration.

5.9 H/\overline{F} (HALF/FULL) - Pin 9

When the pin H/\overline{F} is connected to "SIGNAL COMMON" (logic low), the motor operates in the *full-step mode*.

An open pin (logic high) selects the half-step mode. When operated in the half-step mode the motor provides smoother motion with finer resolution, but at approximately 30% less torque.

NOTE: When a transition from half-step to full-step operation is made, Vm power should be removed to avoid a full-step, one winding on operating mode.

5.10 $\overline{PULSE\ OUT}$ - Pin 10

Produces a pulse (square wave output) from oscillator. Connect to "PULSE IN" by placing position 4 of switch S1 in the "on" (closed) state if an external source is not required.

This is also a test point for monitoring base speed and high speed. This output is an open collector output and should be connected to PULSE IN if used for monitoring purposes.

5.11 DO NOT USE - Pin 11

This pin is not available to the operator.

5.12 SIGNAL COMMON - Pin 12

Reference point for all logic inputs and outputs.

5.13 DO NOT USE - Pin 13

This pin not available to the operator.

5.14 BASE SPEED ONLY - Pin 14

When connected to "SIGNAL COMMON," (logic low) permits only base speed velocity from oscillator.

Frequency Range: 0 Hz to 2500 Hz

There is no acceleration or deceleration when operating at base speed.

If this pin is open (logic high), high speed mode is selected.

5.15 HI SPEED POT 2 - Pin 15

Allows for control of high speed by means of an external potentiometer when used in conjunction with HI SPEED POT 1 (pin #8). As an alternative to using an external potentiometer, the high speed can be controlled by connecting an analog voltage (5 to 9 volts dc) to this input. It will be necessary to "ramp" the analog input to control acceleration and deceleration of the pulse train. Position 3 of switch S1 must be "off" (open) when using analog voltage.

Note: 500k ohm (connected across pins #8 and #15) is recommended when external control is required and position 3 of switch S1 must be "off" (open).

SECTION 6: OPERATING INSTRUCTIONS

6.1 INTRODUCTION

This section outlines the procedures for adding an external high speed potentiometer to the 230-TOH and 430-TOH modules, for setting base speed, and for adjusting high speed, acceleration and deceleration.

6.2 OPERATION FROM EXTERNAL OR ON BOARD POTENTIOMETERS

1. HI SPEED POT 1 and 2 allow connections to a **remote potentiometer for control of HI SPEED setting.**
2. Connect a 500k ohm potentiometer between J1 pins #8 and #15 for external control.

OR:

Connect HI SPEED POT 1 to HI SPEED POT 2 by placing position 3 of switch S1 in the "on" (closed) position when no external control is required.

6.3 BASE SPEED

Base speed is the rate at which a specific motor and load will start of stop with no acceleration or deceleration.

1. Connect BASE SPEED ONLY (J1, pin #14) to SIGNAL COMMON.

RANGE	APPROX. BASE SPEED RANGE	APPROX. HIGH SPEED RANGE	SWITCH POSITIONS			
			S1-1	S1-2	S1-5	S1-6
1	0 — 1250 Hz	0 — 10 kHz	ON	OFF	OFF	ON
2	0 — 2500 Hz	0 — 20 kHz	ON	OFF	ON	OFF
3	0 — 5000 Hz	0 — 50 kHz*	OFF	ON	OFF	ON

* The maximum speed attainable by the drive is 10 kHz

The following table lists approximate settings for Base Speed Potentiometer R4 when using range 2 (0 — 2500 Hz) and with High Speed Potentiometer R3 set for 20 kHz.

BASE SPEED (HZ)	POTENTIOMETER R4 SETTING (number of turns CW from fully CCW position)
0	0
100	4
200	6
400	10-1/2
600	14-1/4
800	16-1/2
1000	18-1/4
1250	19-1/2
1500	20-1/2
1750	21-1/4
2000	22
2500	22-3/4

6.4 HIGH SPEED

HI SPEED POTS 1 AND 2 ARE EITHER CONNECTED TOGETHER (FOR ON BOARD OPERATION) OR ARE CONNECTED TO A REMOTE POTENTIOMETER. (Potentiometer set at minimum resistance.)

1. Make sure that BASE SPEED ONLY (J1 pin #14) is OPEN.
2. Connect RUN (J1 pin #6) to SIGNAL COMMON.
3. Turn HIGH SPEED POT (R3) counterclockwise to increase velocity to desired maximum limit.

Speed (pulse frequency) can be monitored at J-1, pin #10 (PULSE OUT). Position 4 of switch S1 should be "on" (closed).

The settings of "DIP" switch S1, described in 6.3, also affects the High Speed Range as noted in 6.3.

2. Connect RUN (J1, pin #6) to SIGNAL COMMON.
3. Turn "Base Speed Pot" (R4) clockwise to increase base speed. Speed (pulse frequency) can be monitored at J-1, pin #10 (PULSE OUT). Position 4 of switch S1 should be "on" (closed).

Three ranges of Base Speed and High Speed can be selected with DIP switch S1 as follows.

The following table lists approximate settings for High Speed Potentiometer R3 when using range 2 and with Base Speed Potentiometer R4 set for 0 Hz.

BASE SPEED (HZ)	POTENTIOMETER R4 SETTING (number of turns CW from fully CCW position)
0	0
0.15	1/2
0.5	3/4
1	1
2	1-1/2
3	2
4	2-1/2
5	3
7	4
9	5-1/4
10	5-3/4
12	7
14	8-1/2
16	10
18	12
20	13-1/2

NOTE: Because of the oscillator design, the high speed cannot be set lower than the speed set on the base speed potentiometer. For example, if base speed is set to 200 Hz, the high speed can be set no lower than 200 Hz.

6.5 ACCELERATION

Acceleration time to high speed, with the Acel potentiometer (R2) fully counterclockwise is approximately 50 milliseconds. Range is from 50 milliseconds to 2 seconds (approximately).

Measure acceleration with an oscilloscope connected between HI SPEED POT 1 and SIGNAL COMMON. Oscilloscope should be triggered when RUN (J1 pin #6) goes low.

Then make the following settings:

1. Make sure BASE SPEED ONLY is *Open*.
2. Set RUN to *Open*.
This signal must be open circuited long enough to allow complete deceleration.
3. Connect RUN to SIGNAL COMMON (logic low).
4. Measure acceleration time.
5. Adjust Acceleration potentiometer (R2) clockwise to increase acceleration time.
6. Repeat steps 2 - 5 until acceleration is attained.

The following table gives approximate settings for the Acceleration potentiometer (R2).

ACCELERATION TIME (milliseconds)	POTENTIOMETER R2 SETTING (number of turns CW from fully CCW position)
22	0
60	1/2
100	1
200	2
300	3
400	4
500	5
600	6
800	8
1000	10
1250	12-1/2
1500	15
1750	17-1/2
2000	20
2200	22

The acceleration times are essentially unaffected by any potentiometer or switch settings.

6.6 DECELERATION

Deceleration time from high speed to base speed, with the Deceleration potentiometer (R1) fully counterclockwise is 50 milliseconds. Range is from 50 milliseconds to 2 seconds.

Measure deceleration with an oscilloscope connected to HI SPEED POT 1 and SIGNAL COMMON. Oscilloscope should trigger when RUN (J1 pin #6) goes high.

Then make the following settings:

1. Make sure BASE SPEED ONLY is *Open*.
2. Connect RUN (J1 pin #6) to SIGNAL COMMON (low).
Maintain low until high speed is achieved.
3. Remove RUN connection to SIGNAL COMMON.
Maintain until measurement is complete
[Oscilloscope will be triggered when RUN is open. This signal must be open circuited long enough to allow complete deceleration.]
4. Measure deceleration time.

5. Adjust Deceleration potentiometer (R1). Clockwise movement increases deceleration time.

6. Repeat steps 2 - 5 until desired deceleration is reached.

The following table give approximate settings for the Deceleration Potentiometer (R1).

DECELERATION TIME (milliseconds)	POTENTIOMETER R1 SETTING (number of turns CW from fully CCW position)
22	0
60	1/2
100	1
200	2
300	3
400	4
500	5
600	6
800	8
1000	10
1250	13
1500	15-1/2
1750	18
2000	20

6.7 REDUCED CURRENT

6.7.1 Reduced Current for 230-TOH

It is possible to configure the 230-TOH drive to deliver less than 2.0 amps to the motor. To do this, a jumper or a resistor is connected between the LOGIC COMMON (J3 pin #3) and REDUCE CURRENT (J3 pin #4) pins on the motor drive module. These pins protrude through holes in the oscillator circuit board and are shown in Figure 9.0.

Care should be taken to keep the resistor or jumper leads under 2 inches (51mm) long. This signal is not optically isolated. The proper values for resistors and their associated current are:

CURRENT (amperes)	RESISTOR (ohms)
1.00	0 (jumper)
1.25	2.49 k, 1/4 watt, 1%
1.50	7.50 k, 1/4 watt, 1%
1.75	23.7 k, 1/4 watt, 1%
2.0	open

6.7.2 Reduced Current for 430-TOH

The 430-TOH drive can operate at reduced current in the same fashion. The proper resistor values and their associated currents are:

CURRENT (amperes)	RESISTOR (ohms)
1.5	0 (jumper)
2.0	1.78k, 1/4 watt, 1%
2.5	5.62k, 1/4 watt, 1%
3.0	16.2k, 1/4 watt, 1%
3.5	open

TYPICAL SPEED VS. TORQUE CHARACTERISTICS

230 SERIES MOTION CONTROLS

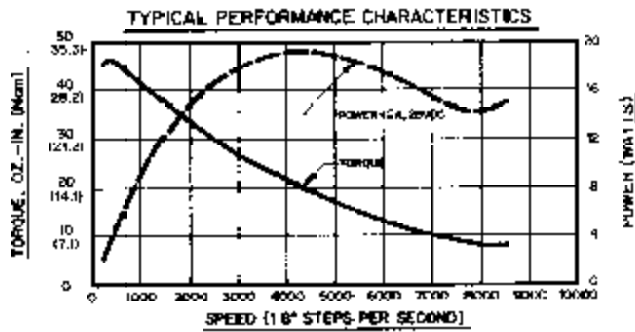

SERIES CONNECTION
MO61-CS08 AND MO61-LS08 MOTORS

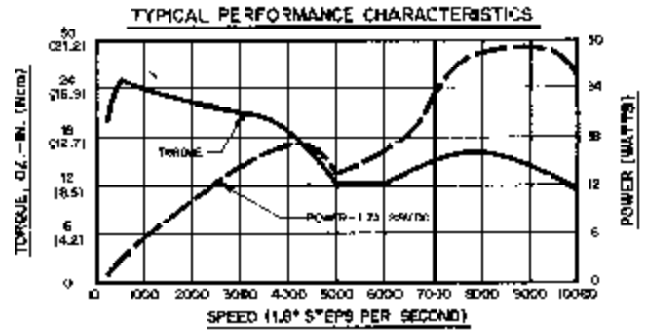

PARALLEL CONNECTION
MO61-CE03 AND MO61-LE03 MOTORS

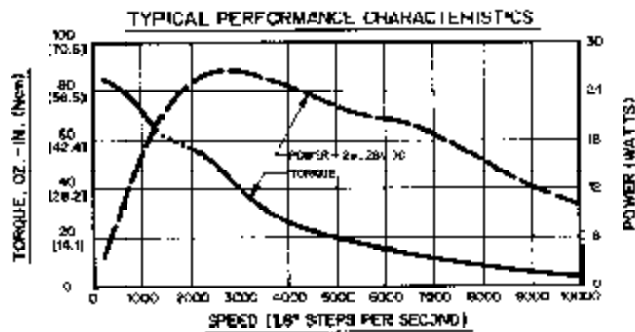

SERIES CONNECTION
MO62-CS09 AND MO62-LS09 MOTORS

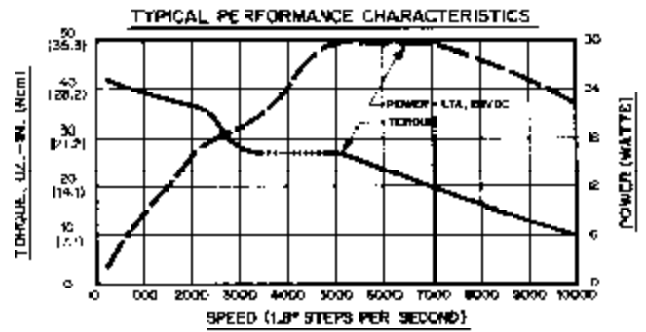

PARALLEL CONNECTION
MO62-CE09 AND MO62-LE09 MOTORS

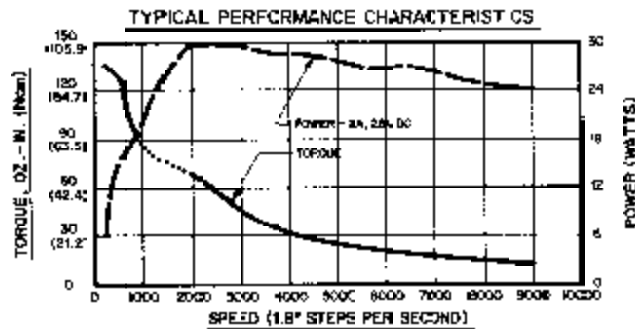

SERIES CONNECTION
MO63-CS09 AND MO63-LS09 MOTORS

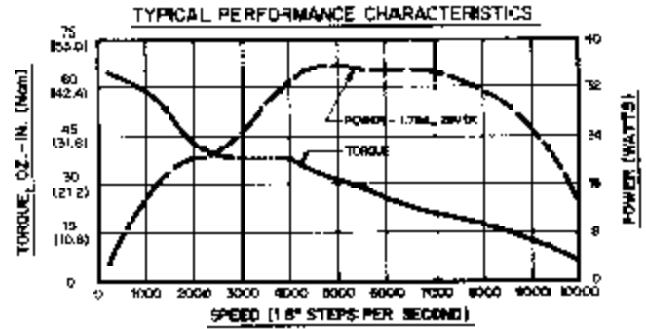

PARALLEL CONNECTION
MO63-CE09 AND MO63-LE09 MOTORS

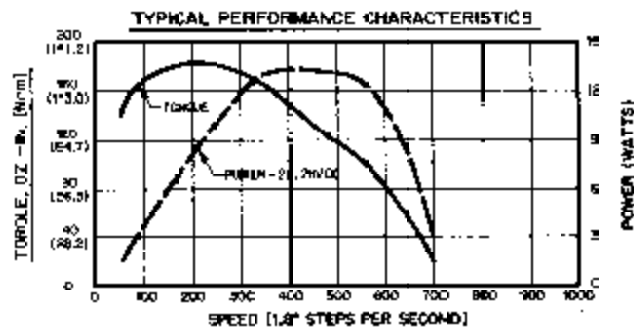

SERIES CONNECTION
MO63-CS06 AND MO63-LS06 MOTORS

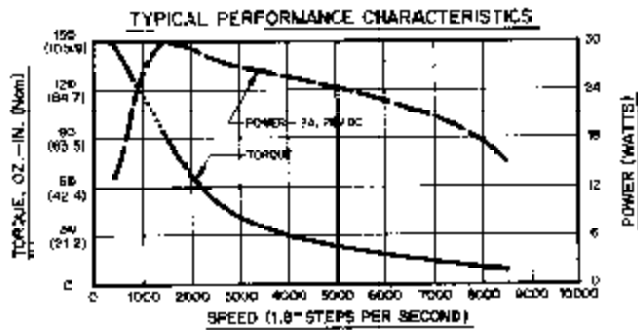

**SERIES CONNECTION
M091-FC09 AND M091-FD09 MOTORS**

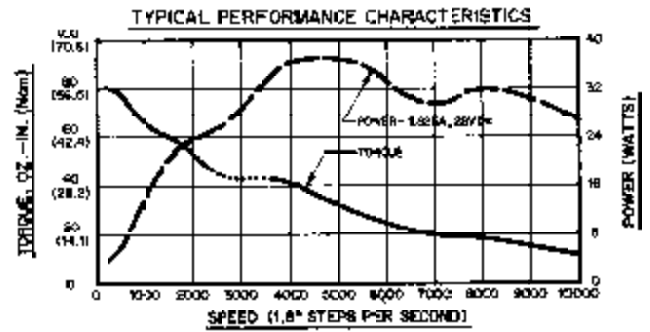

**PARALLEL CONNECTION
M091-FD8009 AND M091-FD8109 MOTORS**

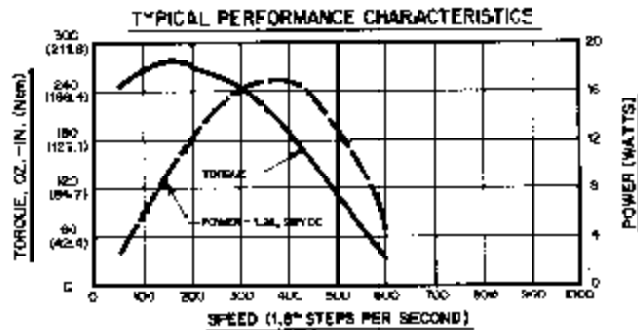

**SERIES CONNECTION
M092-FC09 AND M092-FD09 MOTORS**

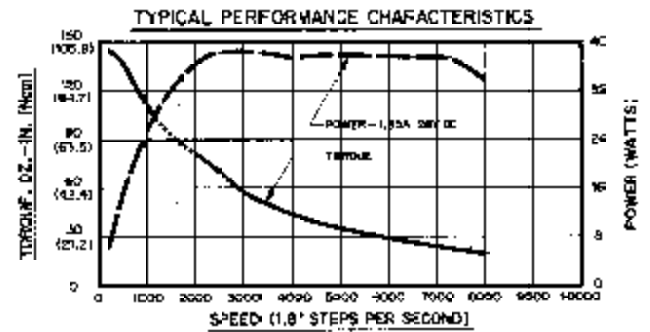

**PARALLEL CONNECTION
M092-FD8109 AND M092-FD8309 MOTORS**

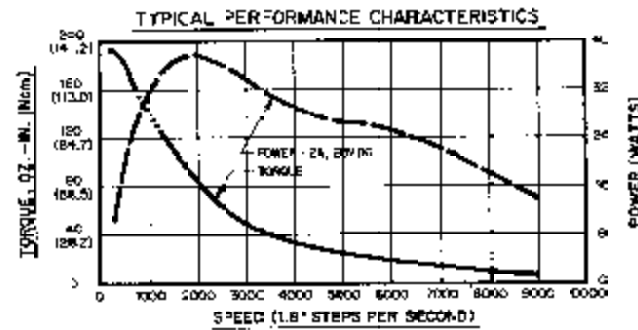

**SERIES CONNECTION
M092-FD310 MOTOR**

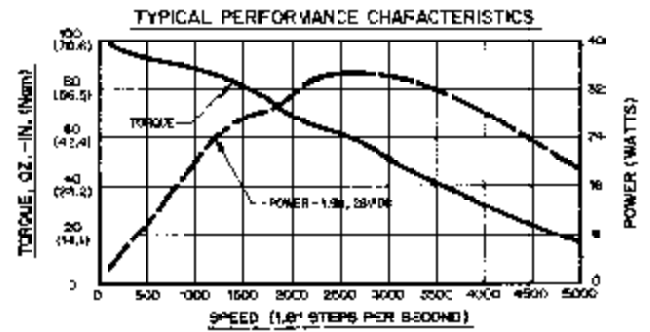

**PARALLEL CONNECTION
M092-FD8814 MOTOR**

TYPICAL SPEED VS. TORQUE CHARACTERISTICS

430 SERIES MOTION CONTROLS

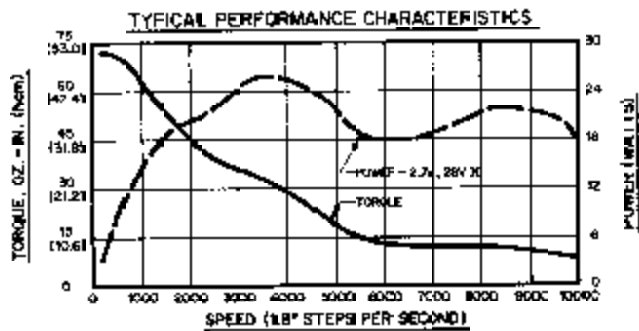

SERIES CONNECTION
MO61-CS08 AND MO61-LS08 MOTORS

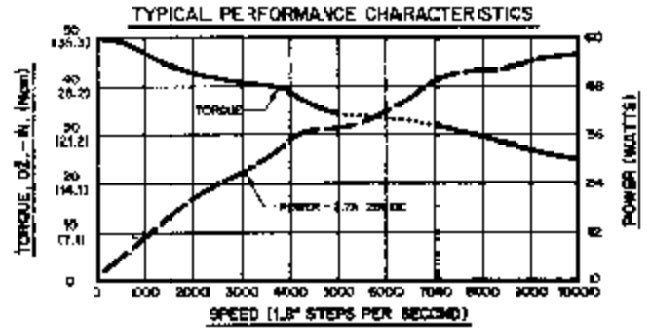

PARALLEL CONNECTION
MO61-CE08 AND MO61-LE08 MOTORS

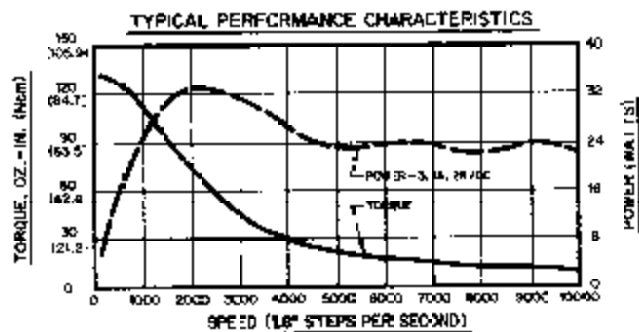

SERIES CONNECTION
MO62-CS09 AND MO62-LS09 MOTORS

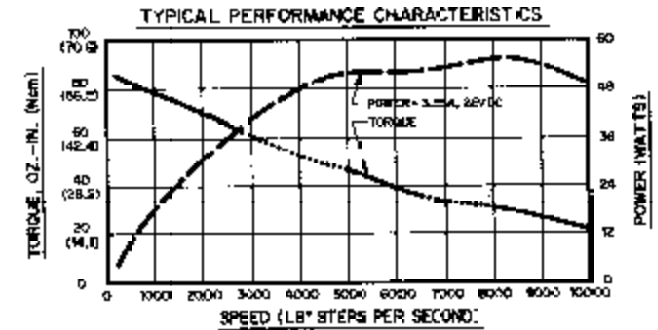

PARALLEL CONNECTION
MO62-CE09 AND MO62-LE09 MOTORS

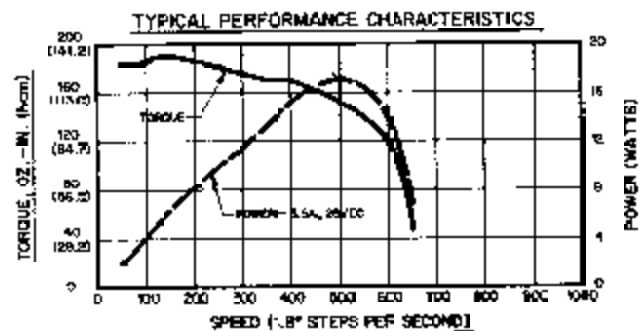

SERIES CONNECTION
MO63-CS06 AND MO63-LS06 MOTORS

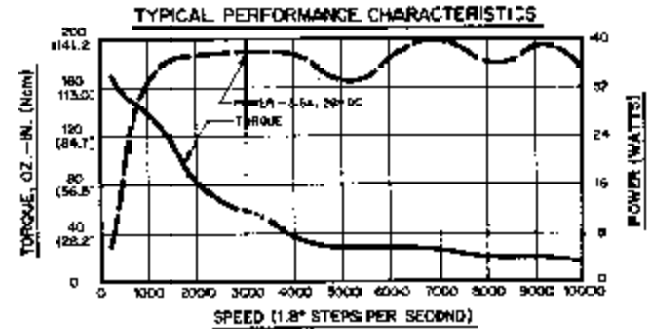

PARALLEL CONNECTION
MO63-CE06 AND MO63-LE06 MOTORS

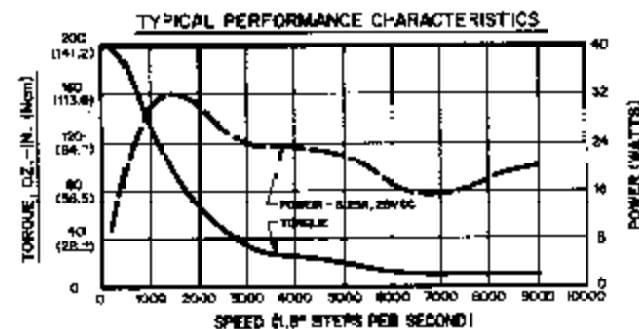

SERIES CONNECTION
MO63-CS09 AND MO63-LS09 MOTORS

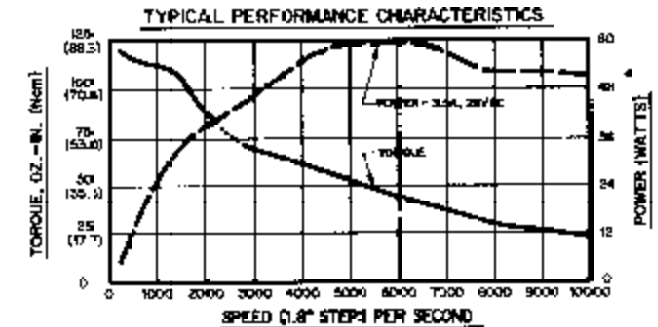

PARALLEL CONNECTION
MO63-CE09 AND MO63-LE09 MOTORS

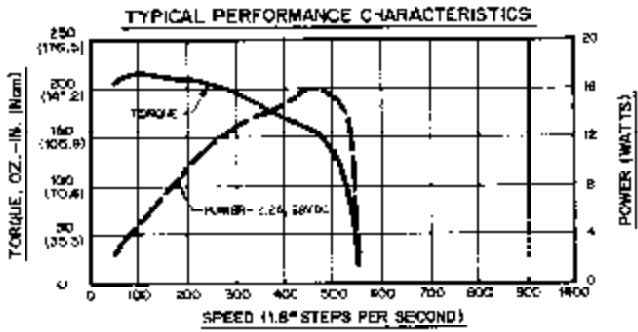

**SERIES CONNECTION
MO91-FC06 AND MO91-FD06 MOTORS**

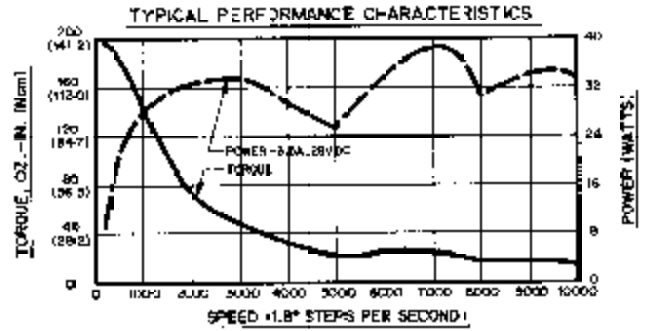

**PARALLEL CONNECTION
MO91-FD06106 MOTOR**

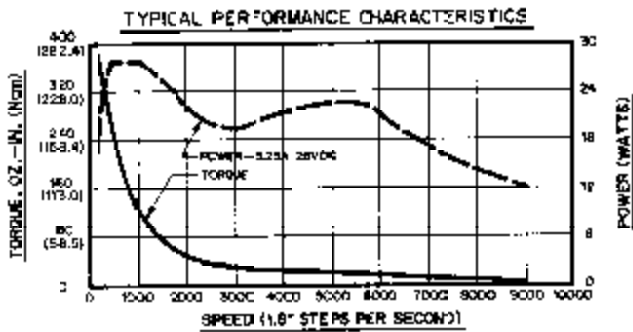

**SERIES CONNECTION
MO92-FC09 AND MO92-FD09 MOTORS**

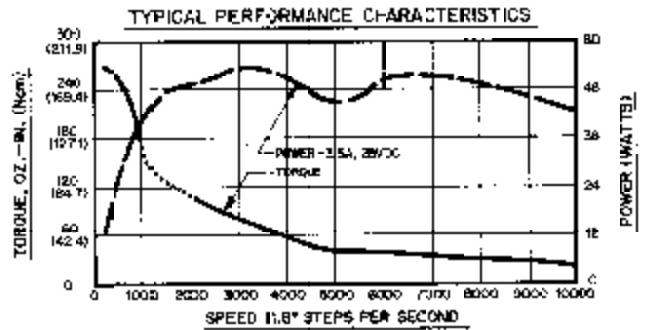

**PARALLEL CONNECTION
MO92-FD8109 AND MO92-FD8009 MOTORS**

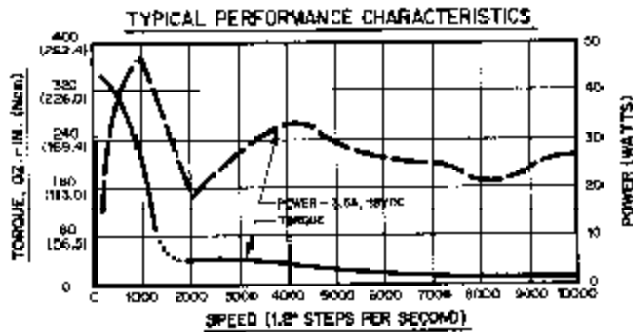

**SERIES CONNECTION
MO92-FD3-10 MOTOR**

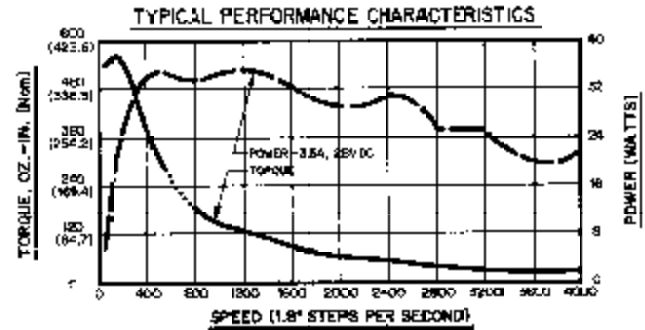

**SERIES CONNECTION
MO93-FD8011 MOTOR**

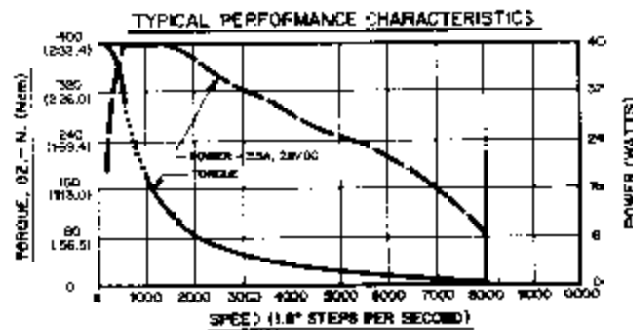

**SERIES CONNECTION
MO93-FC14 AND MO93-FD14 MOTORS**

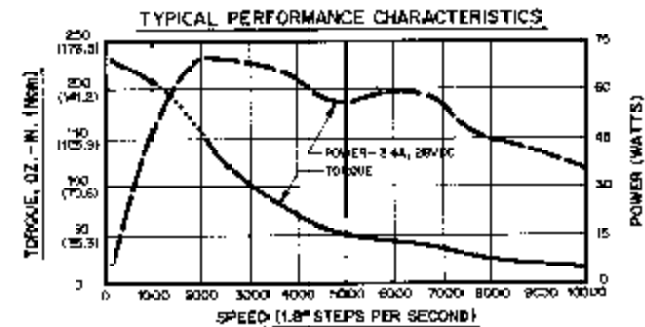

**PARALLEL CONNECTION
MO93-FD8014 MOTOR**

430 SERIES MOTION CONTROLS (Continued)

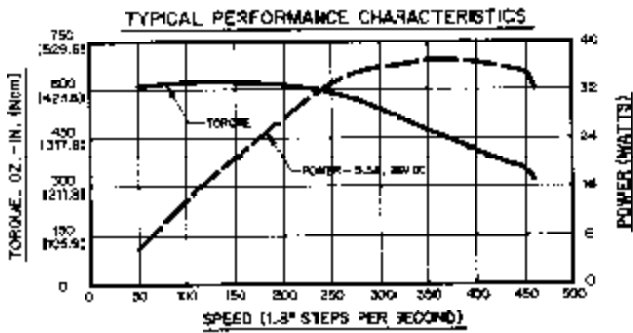

**SERIES CONNECTION
M111-FD12 MOTOR**

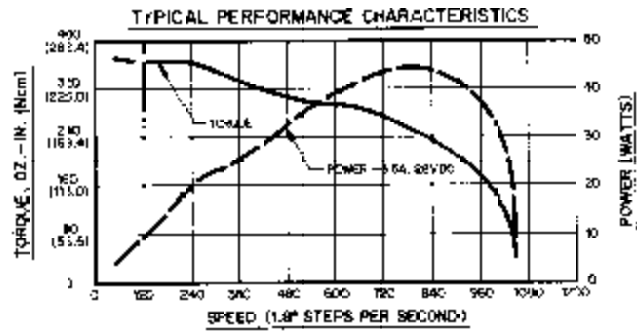

**PARALLEL CONNECTION
M111-FD8012 MOTOR**

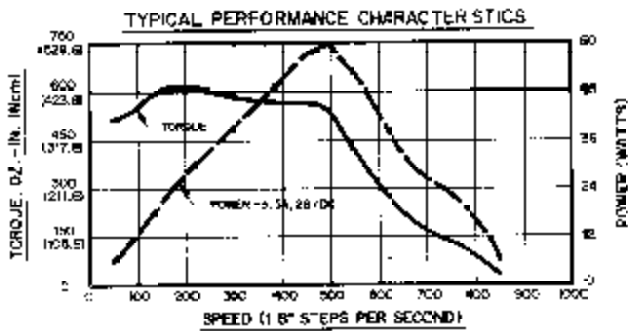

**SERIES CONNECTION
M112-FJ3030 MOTOR**

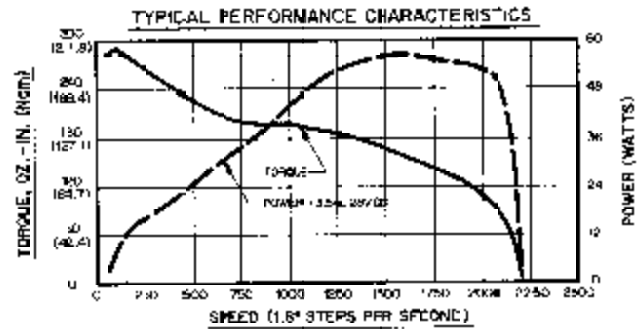

**PARALLEL CONNECTION
M112-FJ8030 MOTOR**

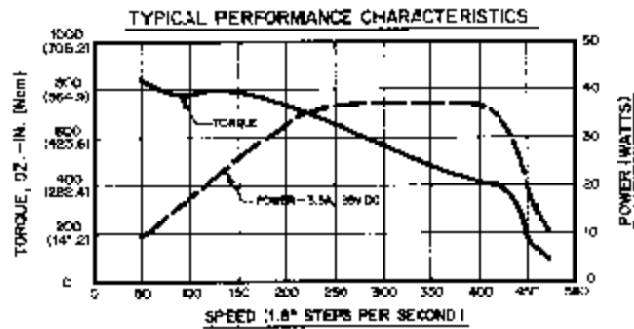

**SERIES CONNECTION
M112-FJ327 MOTOR**

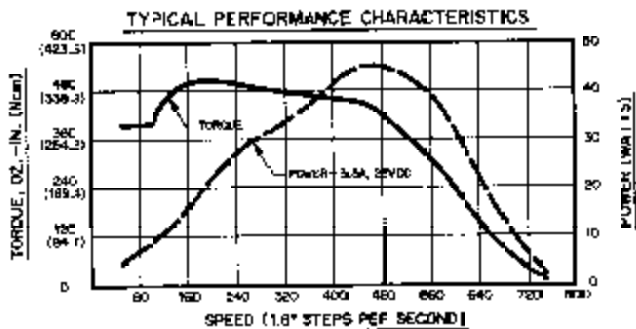

**SERIES CONNECTION
M111-FD16 MOTOR**

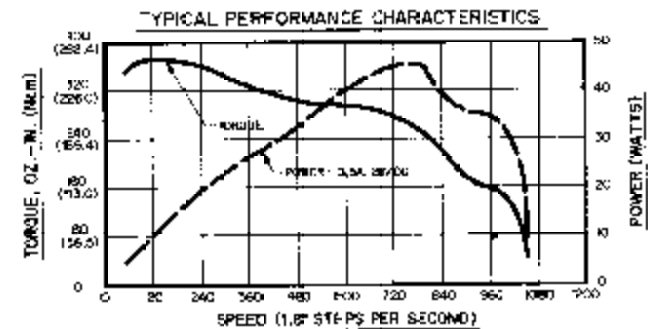

**PARALLEL CONNECTION
M112-FD8012 AND M112-FJ8012 MOTORS**

SECTION 8: TROUBLESHOOTING

WARNING

Motors connected to this drive can develop high torque and large amounts of mechanical energy.

Keep clear of the motor shaft, and all parts mechanically linked to the motor shaft.

Turn off the power to the drive before performing work on parts mechanically coupled to the motor.

If installation and operation instructions have been followed carefully, this unit should perform correctly. If motor fails to step properly, the following checklist will be helpful.

In General:

- Check all installation wiring carefully for wiring errors or poor connections.
- Check to see that the proper DC voltage level is being supplied to the unit.
- Be sure the motor is compatible for use with this unit.

8.1 IF MOTOR DIRECTION (CW, CCW) IS REVERSED, CHECK:

Connections to the J2 Motor Connector are reversed.

8.2 IF THE MOTOR MOTION IS ERRATIC, Check:

- Low filter capacitor
- Input pulses not of proper level or width.
- Supply voltage out of tolerance.
- Motion parameters (base speed, high speed, acceleration/deceleration) may need adjustment.

8.3 IF TORQUE IS LOW, Check:

AWO (All Windings Off) active or REDUCED CURRENT active.
Improper supply voltage.

If a malfunction occurs that cannot be corrected by making these correction, contact Superior Electric.

SECTION 9: COMPONENT LAYOUT

See Figure 9.0 below

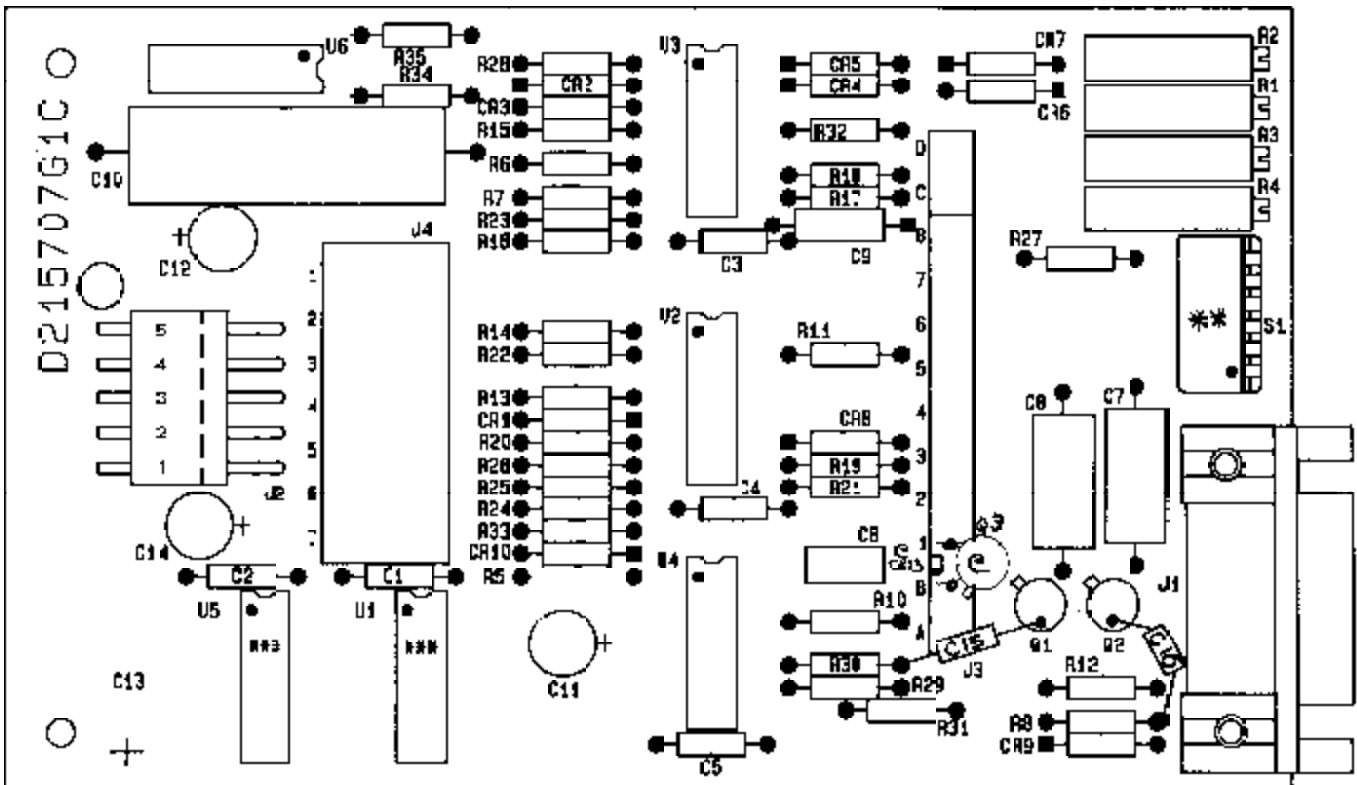

Figure 9.0 Component Layout

Distribution Coast-To-Coast and International

Superior Electric, is a global leader in the engineering, manufacturing, and marketing of precision motion and control products for industrial applications. All SLO-SYN® step motors, servo motors and controls are backed by highly specialized engineers and service people who can help solve your production challenges. Superior Electric's capabilities and products have improved operations for companies around the world.

Through an extensive authorized distributor network, Superior Electric products are available worldwide. These distributors provide convenient services by offering technical support, replacement parts, and literature, as well as an extensive inventory of models off-the-shelf for the fastest possible delivery. Call Superior Electric customer service for ordering and application information or for the address of the nearest authorized distributor for Superior Electric products.

In U.S.A. and Canada

Customer Service: 1-800-787-3532
Product Application: 1-800-787-3532
Product Literature Request: 1-800-787-3532
Fax: 1-800-766-6366

In Europe

Warner Electric (Int.) Inc.

La Pierreire
CH-1029 Villars-Ste-Croix, Switzerland
Tel: 41 21 631 33 55
Fax: 41 21 636 07 04

Superior Electric

SLO-SYN® Step/Servo Motors and Controls
POWERSTAT® Variable Transformers
SUPERCON® Electrical Connectors
BRONCO® AC and DC Drives
NEXTRIVE™ Adjustable Frequency Drives

LUXTROL® Lighting Controls
STABILINE® Power Protection Products
5-WAY® Binding Posts
SECO® Adjustable Speed Drives

Warner Engineered Systems

Integrator of **Superior Electric**, and **Warner Linear** components as well as components of other manufacturers into complete motion control/drive system solutions.

WARRANTY AND LIMITATION OF LIABILITY

Superior Electric, Bristol, Connecticut, warrants to the first end user purchaser (the "purchaser") of equipment manufactured by Superior Electric that such equipment, if new, unused and in original unopened cartons at the time of purchase, will be free from defects in material and workmanship under normal use and service for a period of two years from date of shipment from Superior Electric's factory or a warehouse of Superior Electric in the event that the equipment is purchased from Superior Electric or for a period of two years from the date of shipment from the business establishment of an authorized distributor of Superior Electric in the event that the equipment is purchased from an authorized distributor.

SUPERIOR ELECTRIC'S OBLIGATION UNDER THIS WARRANTY SHALL BE STRICTLY AND EXCLUSIVELY LIMITED TO REPAIRING OR REPLACING, AT THE FACTORY OR A SERVICE CENTER OF SUPERIOR ELECTRIC, ANY SUCH EQUIPMENT OR PARTS THEREOF WHICH AN AUTHORIZED REPRESENTATIVE OF THE COMPANY FINDS TO BE DEFECTIVE IN MATERIAL OR WORKMANSHIP UNDER NORMAL USE AND SERVICE WITHIN SUCH PERIOD OF TWO YEARS. SUPERIOR ELECTRIC RESERVES THE RIGHT TO SATISFY SUCH OBLIGATION IN FULL BE REFUNDING THE FULL PURCHASE PRICE OF ANY SUCH DEFECTIVE EQUIPMENT. This warranty does not apply to any equipment which has been tampered with or altered in any way, which has been improperly installed or which has been subject to misuse, neglect or accident.

THE FOREGOING WARRANTY IS IN LIEU OF ANY OTHER WARRANTIES, EXPRESS OR IMPLIED, INCLUDING, WITHOUT LIMITATION, ANY IMPLIED WARRANTY OF MERCHANTABILITY OR FITNESS FOR A PARTICULAR PURPOSE, and of any other obligations or liabilities on the part of Superior Electric; and no person is authorized to assume for Superior Electric any other liability with respect to equipment manufactured by Superior Electric. Superior Electric shall have no liability with respect to equipment not of its manufacture. SUPERIOR ELECTRIC SHALL HAVE NO LIABILITY WHATSOEVER IN ANY EVENT FOR PAYMENT OF ANY INCIDENTAL OR CONSEQUENTIAL DAMAGES, INCLUDING, WITHOUT LIMITATION, DAMAGES FOR INJURY TO ANY PERSON OR PROPERTY.

Written authorization to return any equipment or parts thereof must be obtained from Superior Electric. Superior Electric shall not be responsible for any transportation charges.

IF FOR ANY REASON ANY OF THE FOREGOING PROVISIONS SHALL BE INEFFECTIVE, SUPERIOR ELECTRIC'S LIABILITY FOR DAMAGES ARISING OUT OF ITS MANUFACTURE OR SALE OF EQUIPMENT, OR USE THEREOF, WHETHER SUCH LIABILITY IS BASED ON WARRANTY, CONTRACT, NEGLIGENCE, STRICT LIABILITY IN TORT OR OTHERWISE, SHALL NOT IN ANY EVENT EXCEED THE FULL PURCHASE PRICE OF SUCH EQUIPMENT.

Any action against Superior Electric based upon any liability or obligation arising hereunder or under any law applicable to the sale of equipment, or the use thereof, must be commenced within one year after the cause of such action arises.

The right to make engineering refinements on all products is reserved. Dimensions and other details are subject to change.

Web Site: www.superiorelectric.com



383 Middle Street • Bristol, CT 06010 USA
Tel: 860.585.4500 • Fax: 860.584.1483



Warner Engineered Systems
13500-J South Point Blvd. • Charlotte, NC 28273
Tel: 704.588.5693 • Fax: 704.588.5695