

AKD®

Using AKD EtherNet/IP with RSLogix Manual



Edition: K, October 2020

Valid for firmware version 1.20

Part Number 903-200009-00

Keep all manuals as a product component during the life span of the product.
Pass all manuals to future users/owners of the product.

KOLLMORGEN®

Because Motion Matters™

Record of Document Revisions:

Revision	Remarks
A, 10/2011	Launch version
C, 06/2012	Changes made to AKD_Jog and AKD_Stop_Smooth instructions.
D, 08/2012	Minor changes made to phrasing and formatting.
E, 09/2013	Information on using Unicast connection added → p. 13.
F, 12/2013	Controller Support (→ p. 7) information updated . Data size of IL.FB corrected in Appendix B: Parameter Listing (→ p. 62).
G, 05/2014	Steps 6 and 7 updated in Quick Start with the AKD Sample Project (→ p. 10).
H, 03/2017	Quick Start with the AKD Sample Project (→ p. 10) updated.
J, 11/2018	Added link to external resources on kollmorgen.com in Quick Start with the AKD Sample Project (→ p. 10).
K, 10/2020	Update to Motion Axis Set Mode Operands table in AKD Instructions (→ p. 28).

EtherNet/IP is a registered trademark of ODVA, Inc.
Windows is a registered trademark of Microsoft Corporation
AKD is a registered trademark of Kollmorgen Corporation

Technical changes which improve the performance of the device may be made without prior notice.

Printed in the United States of America

This document is the intellectual property of Kollmorgen. All rights reserved. No part of this work may be reproduced in any form (by photocopying, microfilm or any other method) or stored, processed, copied or distributed by electronic means without the written permission of Kollmorgen.

1 Table of Contents

1	Table of Contents	3
2	Introduction	7
2.1	Controller Support	7
2.2	Add-On Instructions	7
3	AKD Installation and Setup	9
4	Quick Start with the AKD Sample Project	10
5	Adding AKD Support to a New or Existing Project	11
5.1	Adding the Ethernet IO Module for AKD Communication	11
5.2	Importing the AKD Add-On Instructions to a Project	15
5.3	Using the AKD Add-On Instructions in a Project	21
5.4	Reading and Writing Drive Parameters	24
5.4.1	Read Drive Parameter	24
5.4.2	Write Drive Parameter	26
5.4.3	Execute Drive Command Parameter	26
6	AKD Instructions	28
6.1	Motion Axis Drive Communication (AKD_Drive)	28
6.1.1	Description	28
6.1.2	Operands	28
6.1.3	AKD_DRIVE Structure	28
6.1.4	Execution	29
6.1.5	Changes to Axis Status Bits	29
6.2	Motion Axis On (AKD_Enable)	29
6.2.1	Description	29
6.2.2	Operands	29
6.2.3	AKD_ENABLE Structure	29
6.2.4	Execution	30
6.2.5	Changes to Axis Status Bits	30
6.3	Motion Axis Off (AKD_Disable)	30
6.3.1	Description	30
6.3.2	Operands	30
6.3.3	AKD_DISABLE Structure	31
6.3.4	Execution	31
6.3.5	Changes to Axis Status Bits	31
6.4	Motion Axis Home (AKD_Home)	31
6.4.1	Description	31
6.4.2	Operands	32
6.4.3	AKD_HOME Structure	32
6.4.4	Execution	32
6.4.5	Changes to Axis Status Bits	32
6.5	Motion Axis Jog (AKD_Jog)	33
6.5.1	Description	33
6.5.2	Operands	33
6.5.3	AKD_JOG Structure	33
6.5.4	Programming Guidelines	34

6.5.5 Execution	34
6.5.6 Changes to Axis Status Bits	34
6.6 Motion Axis Move (AKD_Move)	34
6.6.1 Description	34
6.6.2 Operands	35
6.6.3 AKD_MOVE Structure	35
6.6.4 Programming Guidelines	35
6.6.5 Choosing a Move Type	35
6.6.6 Execution	36
6.6.7 Changes to Axis Status Bits	36
6.7 Motion Axis Set Home Mode (AKD_Set_Home_Mode)	36
6.7.1 Description	36
6.7.2 Operands	36
6.7.3 AKD_SET_HOME_MODE Structure	37
6.7.4 Homing Modes	37
6.7.5 Execution	37
6.7.6 Changes to Axis Status Bit	38
6.8 Motion Axis Set Acceleration (AKD_Set_Accel)	38
6.8.1 Description	38
6.8.2 Operands	38
6.8.3 AKD_SET_ACCEL Structure	38
6.8.4 Execution	39
6.8.5 Changes to Axis Status Bits	39
6.9 Motion Axis Set Deceleration (AKD_Set_Decel)	39
6.9.1 Description	39
6.9.2 Operands	39
6.9.3 AKD_SET_DECCEL Structure	40
6.9.4 Execution	40
6.9.5 Changes to Axis Bits	40
6.10 Motion Axis Set Mode (AKD_Set_Mode)	40
6.10.1 Description	40
6.10.2 Operands	41
6.10.3 AKD_SET_MODE Structure	41
6.10.4 Operation Modes	41
6.10.5 Execution	41
6.10.6 Changes to Axis Status Bits	42
6.11 Motion Axis Set Position (AKD_Set_Position)	42
6.11.1 Description	42
6.11.2 Operands	42
6.11.3 AKD_SET_POSITION Structure	43
6.11.4 Execution	43
6.11.5 Changes to Axis Status Bits	43
6.12 Motion Axis Set Velocity (AKD_Set_Velocity)	43
6.12.1 Description	43
6.12.2 Operands	44
6.12.3 AKD_SET_VELOCITY Structure	44
6.12.4 Execution	44

6.12.5 Changes to Axis Status Bits	44
6.13 Motion Axis Shutdown (AKD_Shutdown)	45
6.13.0.1 Description	45
6.13.1 Operands	45
6.13.2 AKD_SHUTDOWN Structure	45
6.13.3 Execution	46
6.13.4 Changes to Axis Status Bits	46
6.14 Motion Axis Shutdown Reset (AKD_Shutdown_Reset)	46
6.14.1 Description	46
6.14.2 Operands	46
6.14.3 AKD_SHUTDOWN_RESET Structure	47
6.14.4 Execution	47
6.14.5 Changes to Axis Status Bits	47
6.15 Motion Axis Smooth Stop (AKD_Stop_Smooth)	47
6.15.1 Description	47
6.15.2 Operands	48
6.15.3 AKD_STOP_SMOOTH Structure	48
6.15.4 Execution	48
6.15.5 Changes to Axis Status Bits	48
6.16 Motion Axis Get Position Controller Attribute (AKD_Get_Attribute)	49
6.16.1 Description	49
6.16.2 Operands	49
6.16.3 AKD_GET_ATTRIBUTE Structure	49
6.16.4 Execution	50
6.16.5 Changes to Axis Status Bits	50
6.17 Motion Axis Get Parameter (AKD_Get_Parameter)	50
6.17.1 Description	50
6.17.2 Operands	50
6.17.3 AKD_GET_PARAMETER Structure	51
6.17.4 Execution	51
6.17.5 Changes to Axis Status Bits	51
6.18 Motion Axis Set Position Controller Attribute (AKD_Set_Attribute)	51
6.18.1 Description	51
6.18.2 Operands	52
6.18.3 AKD_SET_ATTRIBUTE Structure	52
6.18.4 Execution	52
6.18.5 Changes to Axis Status Bits	52
6.19 Motion Axis Set Parameter (AKD_Set_Parameter)	53
6.19.1 Description	53
6.19.2 Operands	53
6.19.3 AKD_SET_PARAMETER Structure	53
6.19.4 Execution	53
6.19.5 Changes to Axis Status Bits	54
6.20 Motion Axis Set Units (AKD_Set_Units)	54
6.20.1 Description	54
6.20.2 Operands	54
6.20.3 AKD_SET_UNITS Structure	54

6.20.4 Execution	55
6.20.5 Changes to Axis Status Bits	55
6.21 Motion Axis Torque (AKD_Torque_Move)	55
6.21.1 Description	55
6.21.2 Operands	55
6.21.3 AKD_TORQUE_MOVE Structure	56
6.21.4 Programming Guidelines	56
6.21.5 Execution	56
6.21.6 Changes to Axis Status Bits	56
6.22 Fault Reset (AKD_Fault_Reset)	57
6.22.1 Description	57
6.22.2 Operands	57
6.22.3 AKD_FAULT_RESET Structure	57
6.22.4 Programming Guidelines	57
6.22.5 Execution	58
6.22.6 Changes to Axis Status Bits	58
7 Troubleshooting	59
7.1 Introduction	59
7.2 .ER (Error) bit	59
7.2.1 Unconfigured Axis was Specified	59
7.2.2 Communication Timeout	59
7.2.3 Operand value out of range	60
7.3 AKD Fault	60
7.3.1 Fieldbus Fault – F702	60
8 Appendix A: EtherNet/IP Objects and Attributes	61
8.1 Position Controller Object 0x25	61
9 Appendix B: Parameter Listing	62
10 Appendix C: RSLogix 500	84
10.1 PLC & Drive TCP/IP Settings	85
10.2 Read Explicit Message Setup	86
10.3 Write Explicit Message Setup	88

2 Introduction

This manual provides an easy start guide for using AKD with RSLogix5000, an overview on how to import and configure the AKD Add-On instructions using RSLogix5000 version 16 or later, as well as a reference to the Add-On instructions.

RSLogix sample projects and add-on instructions, which demonstrate an EtherNet/IP network with a Compact Logix controller and the AKD are available on kollmorgen.com.

The sample projects are based on an L32E CompactLogix controller, which can easily be changed to another controller which supports RSLogix5000.

This document assumes that the reader has a basic knowledge of EtherNet/IP protocols, AKD drives, and Rockwell RSLogix5000.

2.1 Controller Support

The Add-On Instructions described in this manual are only supported on CompactLogix and ControlLogix controllers. A sample project is available on kollmorgen.com.

MicroLogix 1400 controllers are supported but the Add-On Instructions provided with RSLogix5000 cannot be used. Only explicit messaging is supported.

MicroLogix 1100 and SLC500 are not supported.

2.2 Add-On Instructions

The AKD Add-On Instructions are RSLogix instructions that define AKD drives and axis configurations. These instructions are made to be imported into an RSLogix5000 project. Once defined in a project, they function just as a native RSLogix instruction. The add-on instructions encapsulate the most commonly used logic for AKD axes. They provide easily reusable tools to operate drives and axes, promoting consistency across different projects.

Note that the native MSG instruction is used in RSLogix for sending Explicit Messages.

A set of Add-On instructions are provided for easy creation of AKD programs with RSLogix. The instructions are written to mirror the native instructions, leveraging existing knowledge of the software. They provide easy control of IO Assembly messages.

Add-On Instructions include:

- AKD_Disable
- AKD_Drive
- AKD_Enable
- AKD_Fault_Reset
- AKD_Get_Attribute
- AKD_Get_Parameter
- AKD_Home
- AKD_Jog
- AKD_Move
- AKD_Set_Accel
- AKD_Set_Attribute
- AKD_Set_Decel
- AKD_Set_Home_Mode
- AKD_Set_Mode
- AKD_Set_Parameter
- AKD_Set_Position
- AKD_Set_Units
- AKD_Set_Velocity
- AKD_Shutdown
- AKD_Shutdown_Reset

- AKD_Stop_Smooth
- AKD_Torque_Move

3 AKD Installation and Setup

See the following manuals for installation and setup of an AKD drive:

- AKD Installation Manual. This manual provides instructions for installation and drive setup.
- AKD WorkBench Online Help. This help system describes how to use your drive in common applications. It also provides tips for maximizing your system performance with the AKD. The Online Help includes the Parameter and Command Reference Guide which provides documentation for the parameters and commands used to program the AKD.
- Accessories Manual. This manual provides documentation for accessories like cables and regen resistors used with AKD. Regional versions of this manual exist.
- AKDEtherNet/IP Communication Guide. This guide describes the communication profile and use of EtherNet/IP with the AKD.

4 Quick Start with the AKD Sample Project

The [Add On Instruction Library for AKD Ethernet IP](#) can be downloaded from kollmorgen.com.

This zip file contains:

1. The most recent library of Add On Instructions and Data Types (see Chapter 5 for details).
2. Summary of the library, including revision number of each AOI.
3. Change log indicating historical changes and fixes/enhancements.
4. The Getting Started With AKD Ethernet IP application note.
5. The Simple Example Program *.ACD project.

For application notes, FAQ and other supplementary AKD EtherNet/IP support, see the [AKD EtherNet/IP Support Landing Page](#) on the Kollmorgen website.

5 Adding AKD Support to a New or Existing Project

5.1 Adding the Ethernet IO Module for AKD Communication

These basic instructions can be used for any Rockwell PLC that uses RSLogix5000 and supports Ether-Net/IP.

1. Start RSLogix5000 and open the project with which you want to use the AKD drive.
2. Right click on the Ethernet port in the I/O Configuration and select “New Module...” (Figure 5-1: Adding New Module)

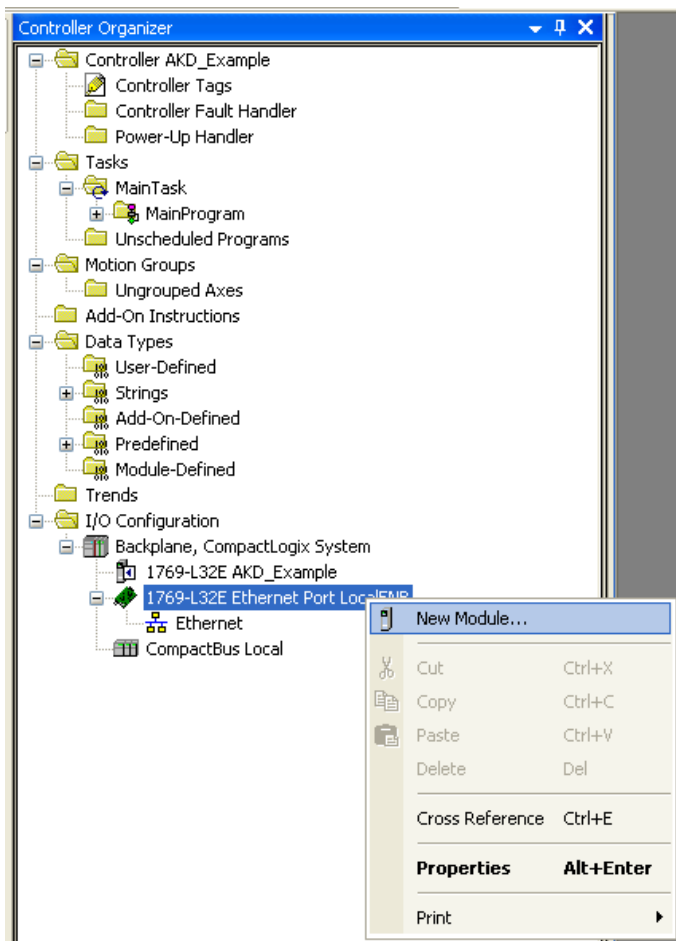

Figure 5-1: Adding New Module

3. Select “ETHERNET-MODULE” under “Communications” and click OK (Figure 5-2: Selecting Module Type)

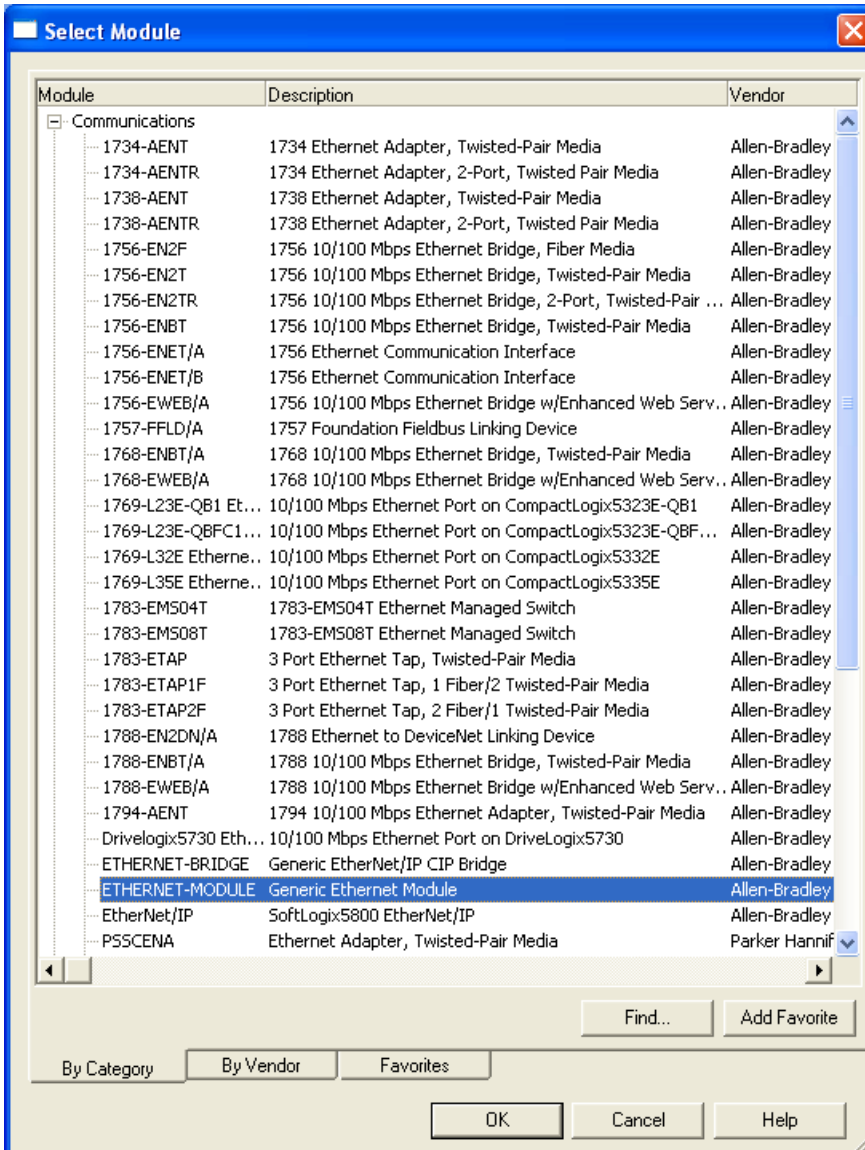

Figure 5-2: Selecting Module Type

4. Enter the settings for the new module as described below, make sure the “Open Module Properties” checkbox is checked, and click OK (Table 4 1: Module Setting Values & Figure 5-3: Entering Module Settings)

Field	Value
Name	AKD_Drive
Description	Text description for drive
Comm Format	Data--SINT
IP Address	Ethernet IP address for drive
Input Assembly Instance	102
Input Size	64
Output Assembly Instance	101
Output Size	64

Field	Value
Configuration Assembly Instance	100
Configuration Size	0

Table 5-1: Module Setting Values

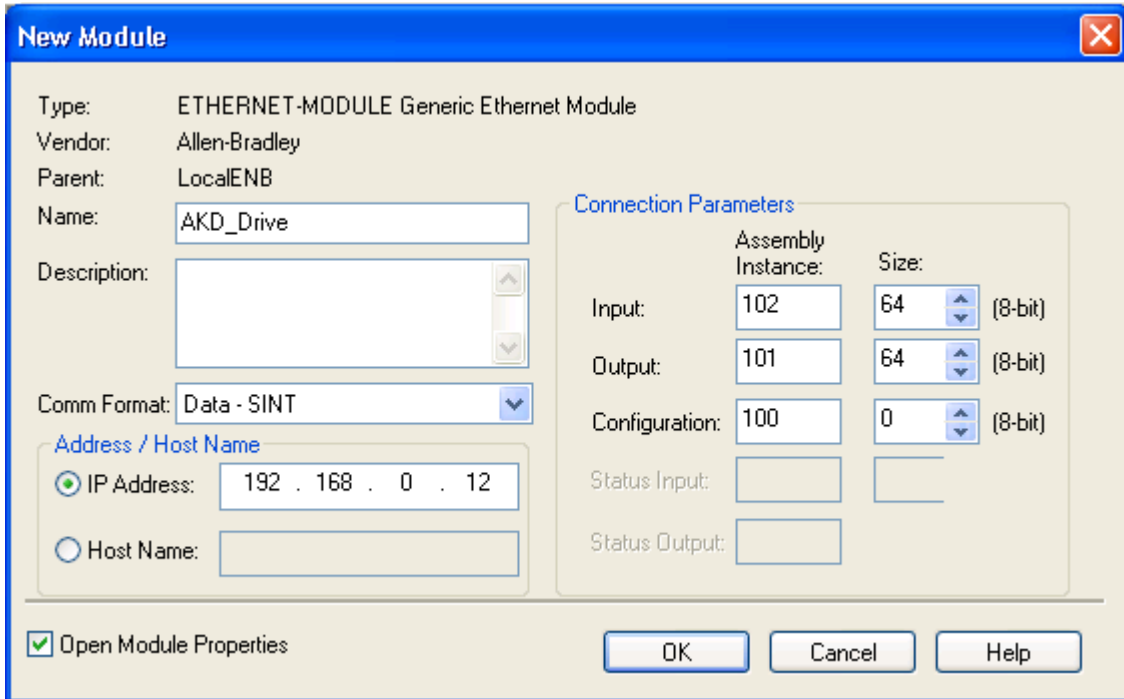

Figure 5-3: Entering Module Settings

- The “New Module” window now appears as a “Module Properties: LocalENB” window with the Connection tab selected. Set the “Requested Packet Interval (RPI)” value to 20.0 ms (this can be reduced to 10.0ms when not using WorkBench in combination with EtherNet/IP). If using firmware version 1.8 or higher, check the box “Use Unicast Connection over EtherNet/IP” if the option is available. For older versions of firmware leave this box unchecked. Click OK. (Figure 5-4: Setting Module RPI).

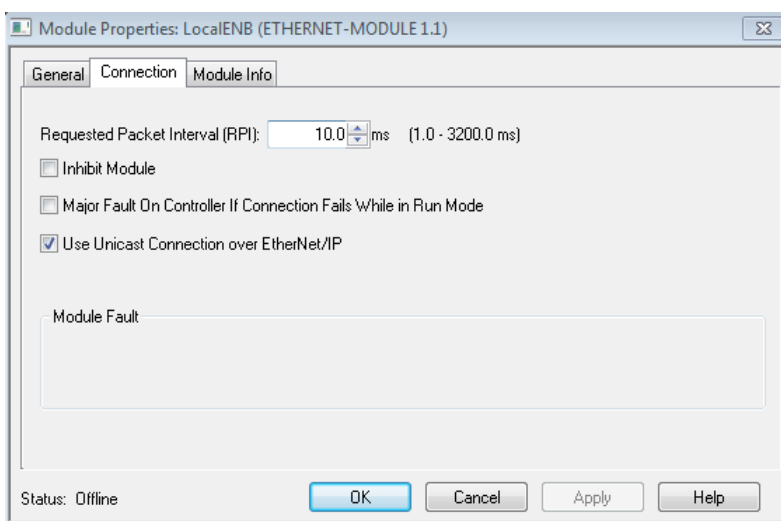

Figure 5-4: Setting Module RPI

6. The drive should now be configured and will show up under the Ethernet Port (Figure 5-5: Module Successfully Added to Project)

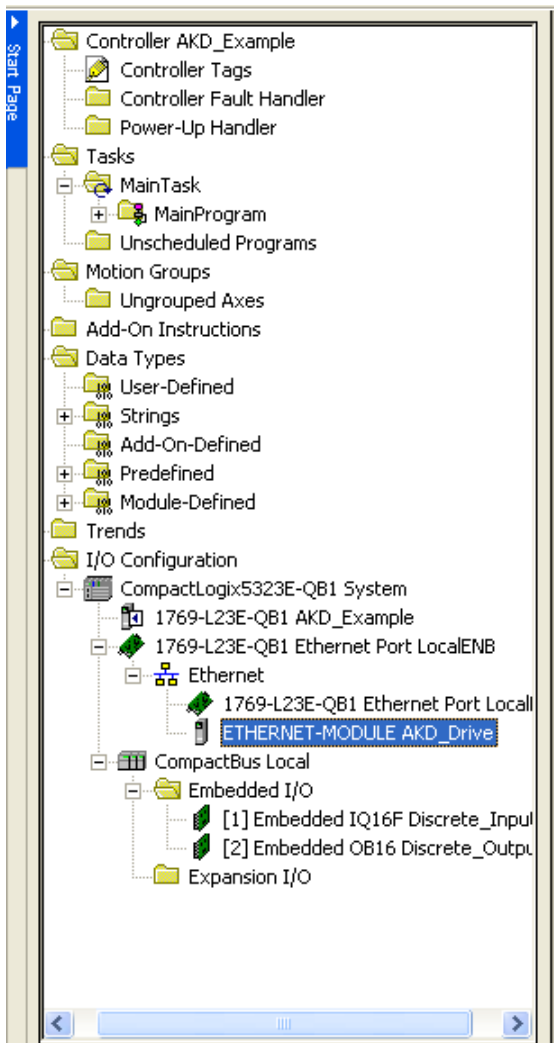

Figure 5-5: Module Successfully Added to Project

7. Make sure that the Ethernet port for your controller is setup with a compatible IP address on the same subnet as the AKD drive IP address. This can be configured by right-clicking on 1769-L23E-QB1 Ethernet Port Local and selecting properties. See your controller user manual for more information.

5.2 Importing the AKD Add-On Instructions to a Project

NOTE

The User Defined Data Types must be imported before the Add-On Instructions.

1. Right click the “User-Defined” folder under “Data Types” and select “Import Data Type...” (Figure 5-6: Importing Data Types)

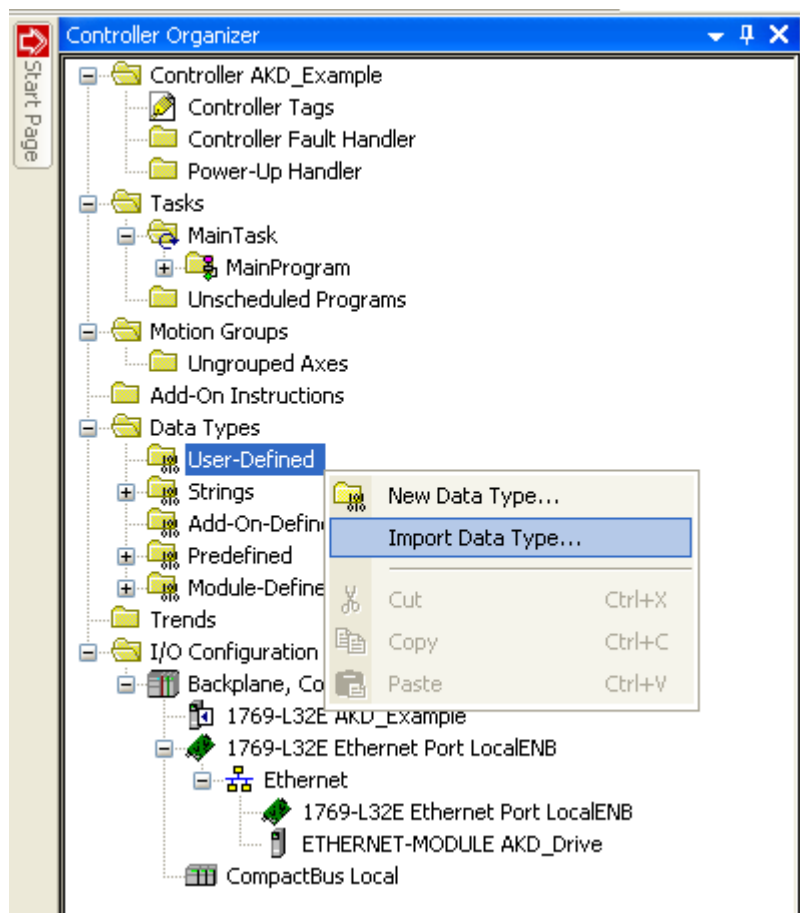

Figure 5-6: Importing Data Types

2. Browse to the location of the AKD User Defined Data Type library and select the desired User Defined Data Type then click “Import...” (Figure 5-7: Selecting a UDT)
 1. Import the data types in the order shown in Table 5-2: UDT Import Order.

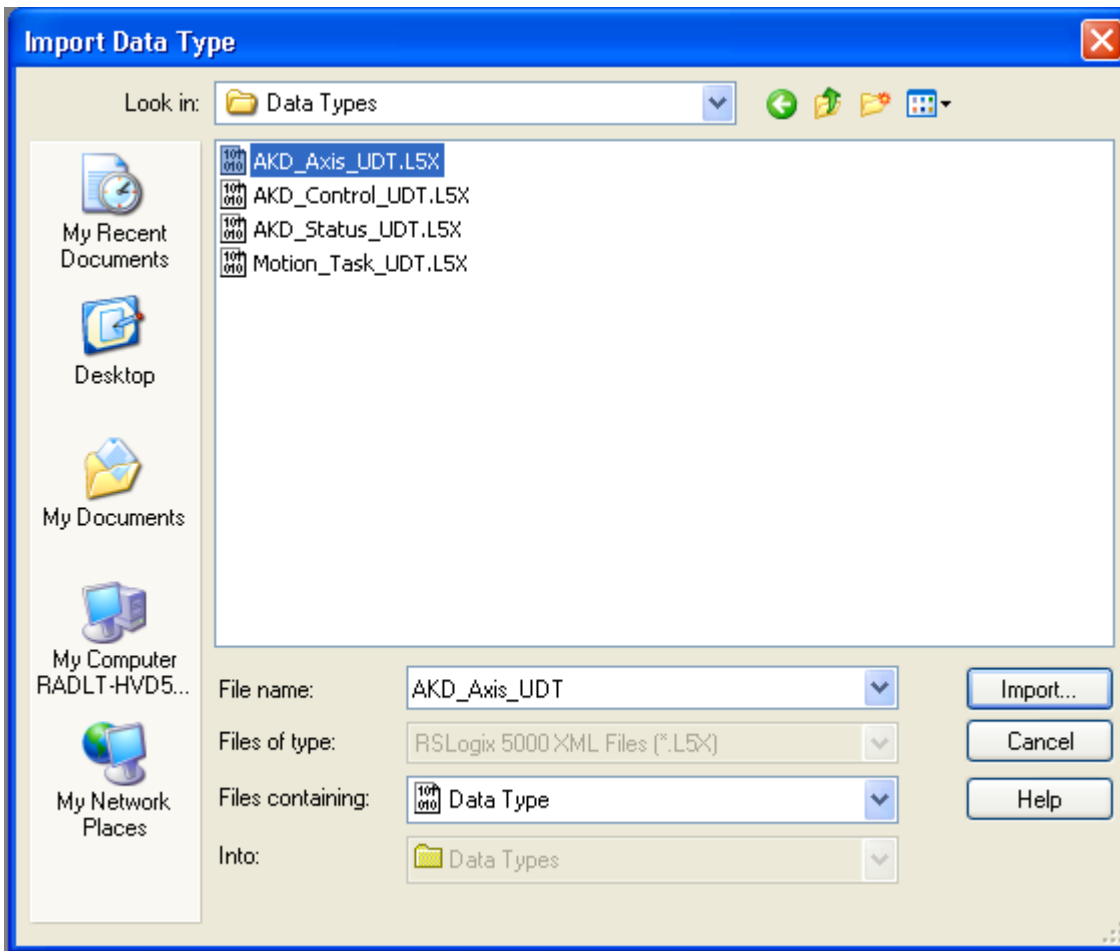

Figure 5-7: Selecting a UDT

Order	File	Description
1	AKD_Control_UDT.L5X	Control message for sending to axis
2	AKD_Status_UDT.L5X	Status message for updating from axis
3	AKD_Axis_UDT.L5X	Axis definition
4	Motion_Task_UDT.L5X	Motion Task data table structure

Table 5-2: UDT Import Order

3. Click OK on the import configuration dialog, if one appears. Repeat for all files in “Table 5-2: UDT Import Order” to import all of the needed data types
4. The data types should now show up under the “Data Types > User-Defined” folder (Figure 5-8: Data Types Successfully Imported)

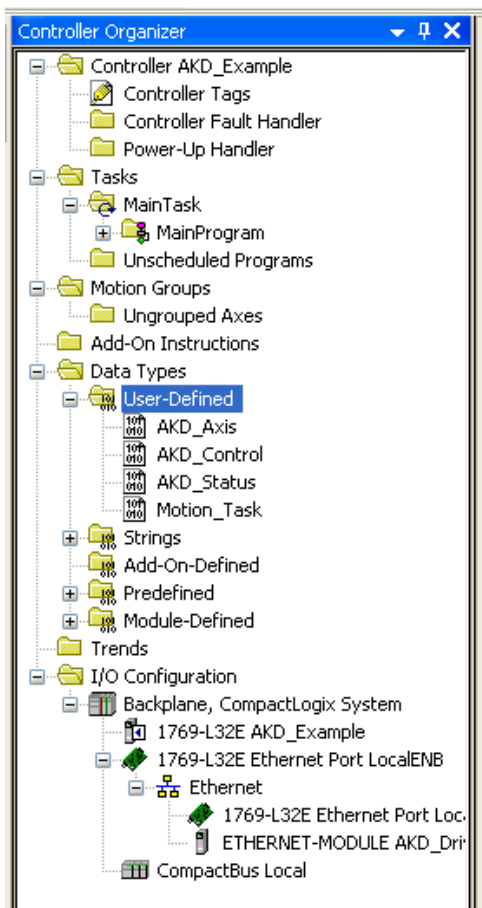

Figure 5-8: Data Types Successfully Imported

5. Next, to import the add-on instructions, right click on the “Add-On Instructions” folder and select “Import Add-On Instruction...” (Figure 5-9: Importing Add-On Instructions)

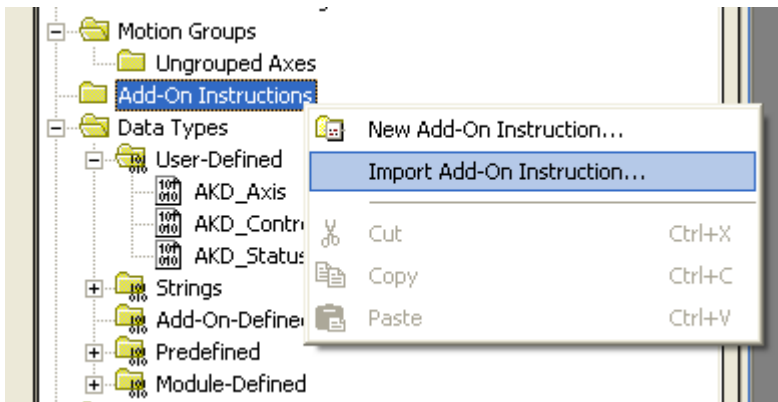

Figure 5-9: Importing Add-On Instructions

6. Browse to the location of the AKD Add On Instruction library and select the desired AOI then click “Import...” (Figure 5-10: Selecting an AOI)
 1. For complete functionality, import all of the files listed in “Table 5-3: All Add On Instructions”

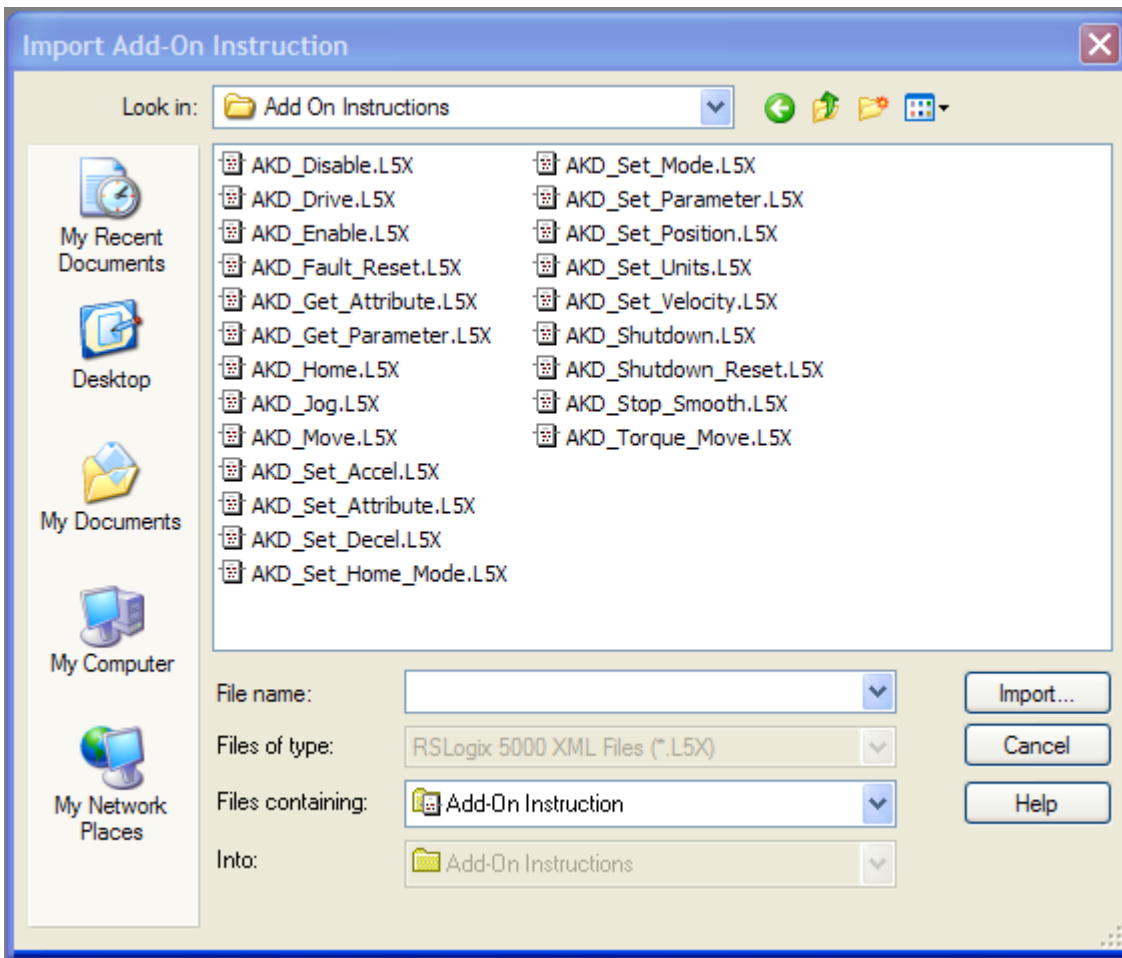

Figure 5-10: Selecting an AIO

File	Description
AKD_Disable_AOI.L5X	Motion Axis Off
AKD_Drive_AOI.L5X	Drive Communication
AKD_Enable_AOI.L5X	Motion Axis On
AKD_Fault_Reset_AOI.L5X	Motion Axis Fault Reset
AKD_Get_Attribute_AOI.L5X	Get Axis Attribute
AKD_Get_Parameter_AOI.L5X	Get Axis Parameter
AKD_Home_AOI.L5X	Motion Axis Home
AKD_Jog_AOI.L5X	Motion Axis Jog
AKD_Move_AOI.L5X	Motion Axis Move
AKD_Set_Accel_AOI.L5X	Motion Axis Set Acceleration
AKD_Set_Attribute_AOI.L5X	Set Axis Attribute
AKD_Set_Decel_AOI.L5X	Motion Axis Set Deceleration
AKD_Set_Home_Mode_AOI.L5X	Motion Axis Set Home Mode
AKD_Set_Mode_AOI.L5X	Motion Axis Set Mode

File	Description
AKD_Set_Parameter_AOI.L5X	Set Axis Parameter
AKD_Set_Position_AOI.L5X	Motion Axis Set Position
AKD_Set_Units_AOI.L5X	Motion Axis Set Units
AKD_Set_Velocity_AOI.L5X	Motion Axis Set Velocity
AKD_Shutdown_AOI.L5X	Motion Axis Shutdown
AKD_Shutdown_Reset_AOI.L5X	Motion Axis Shutdown Reset
AKD_Stop_Smooth_AOI.L5X	Motion Axis Smooth Stop
AKD_Torque_Move_AOI.L5X	Motion Axis Torque

Table 5-3: All Add On Instructions

7. Click OK on the import configuration dialog, if any appear. Repeat for all files in “Table 5-3: All Add On Instructions” to import all of the needed instructions for full functionality
8. The instructions should now show up under the “Add-On Instructions” folder (Figure 5-11: AOI's Successfully Imported)

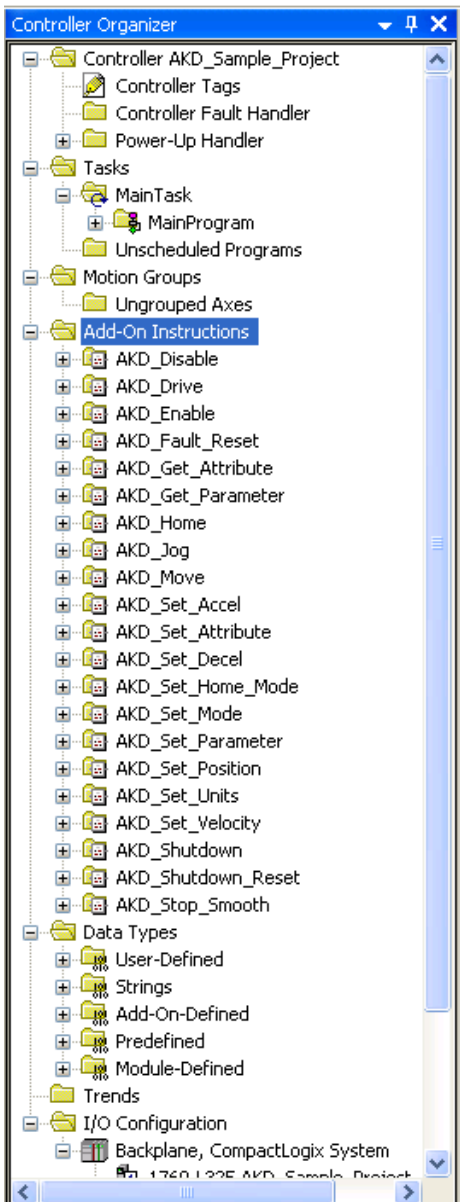

Figure 5-11: AOI's Successfully Imported

5.3 Using the AKD Add-On Instructions in a Project

In any project where you want to use the AKD Add-On instructions, you will need to include one instance of the Drive Communication logic for each axis (AKD_Drive instruction).

1. Add the AKD_Drive instruction to your ladder diagram.

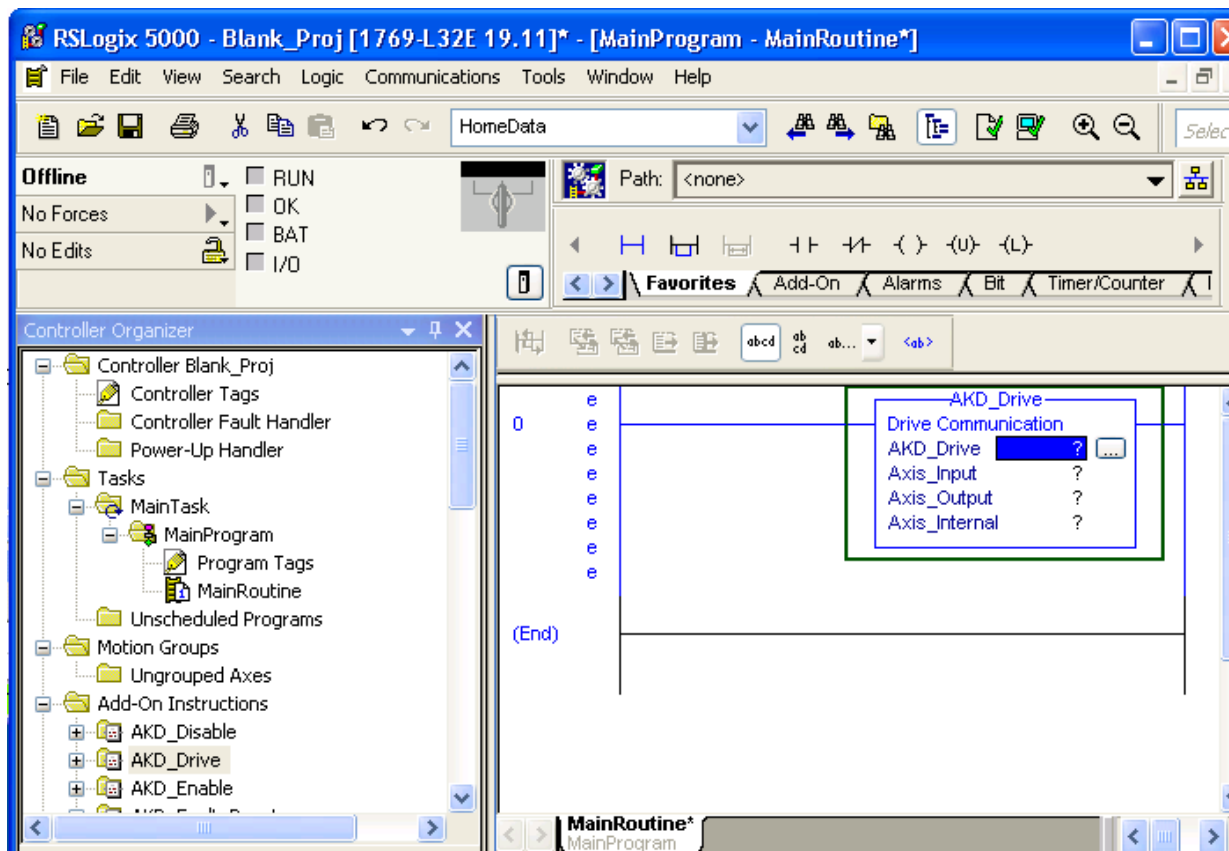

Figure 5-12: AKD_Drive Instruction

2. Right click the AKD_Drive parameter (first question mark) in the AKD_Drive instruction, and select New Tag...

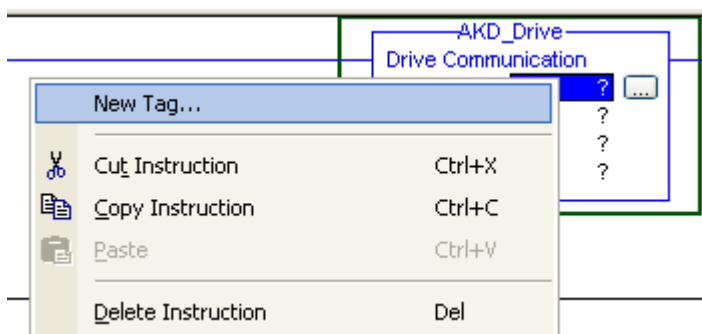

Figure 5-13: Add New Instruction Tag

3. Fill in a name and description. The data type should be AKD_Drive.

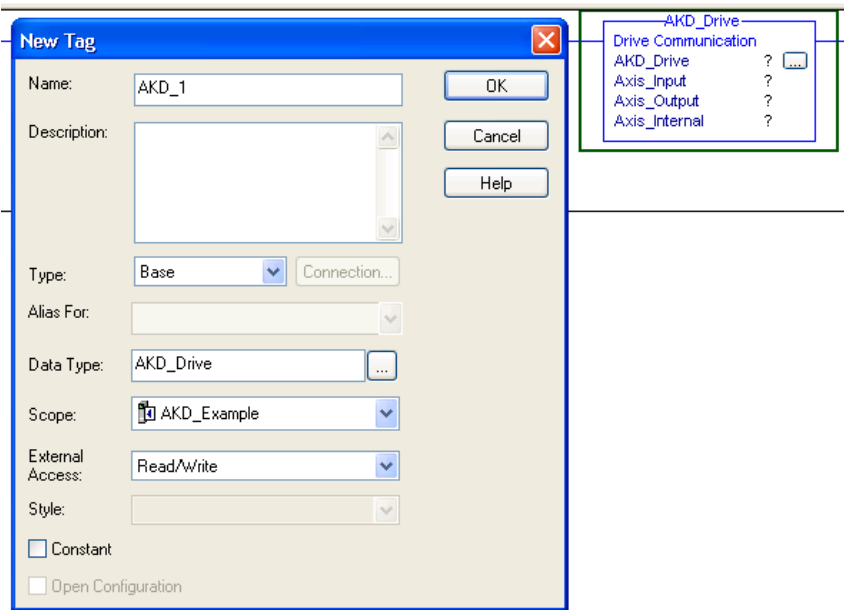

Figure 5-14: Adding Drive Communication

4. Click OK in the New Tag window to create your tag. It will now show up in your controller under “Controller Tags”

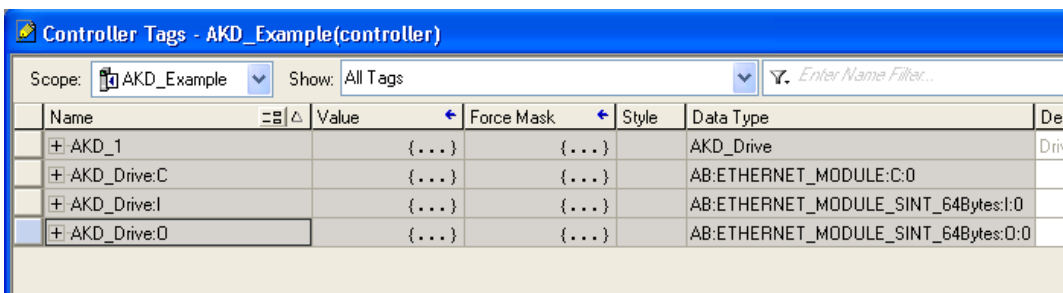

Figure 5-15: Tag Added to Program

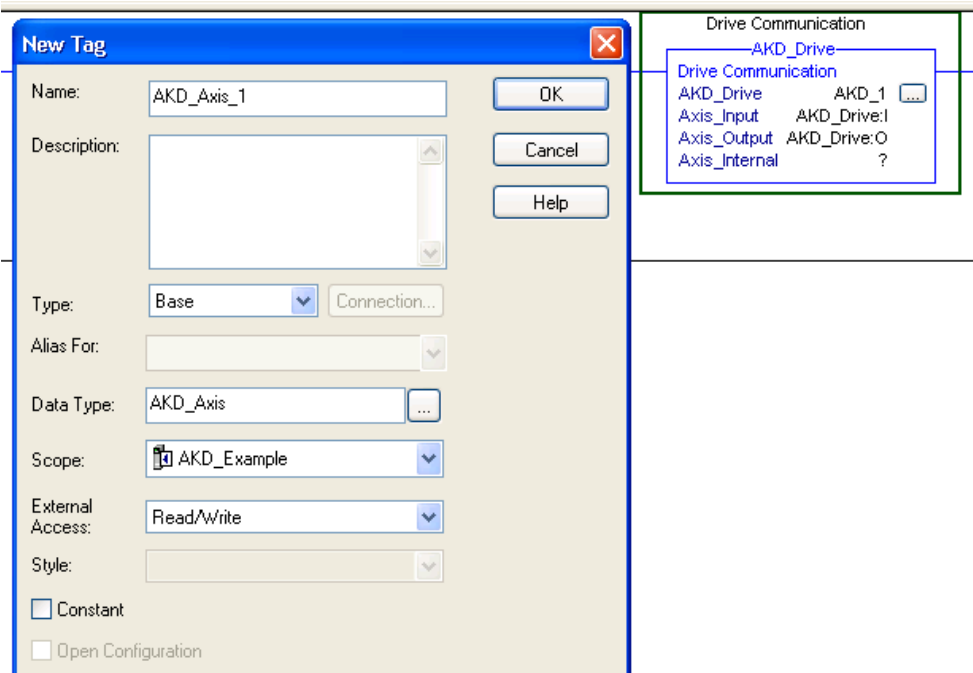
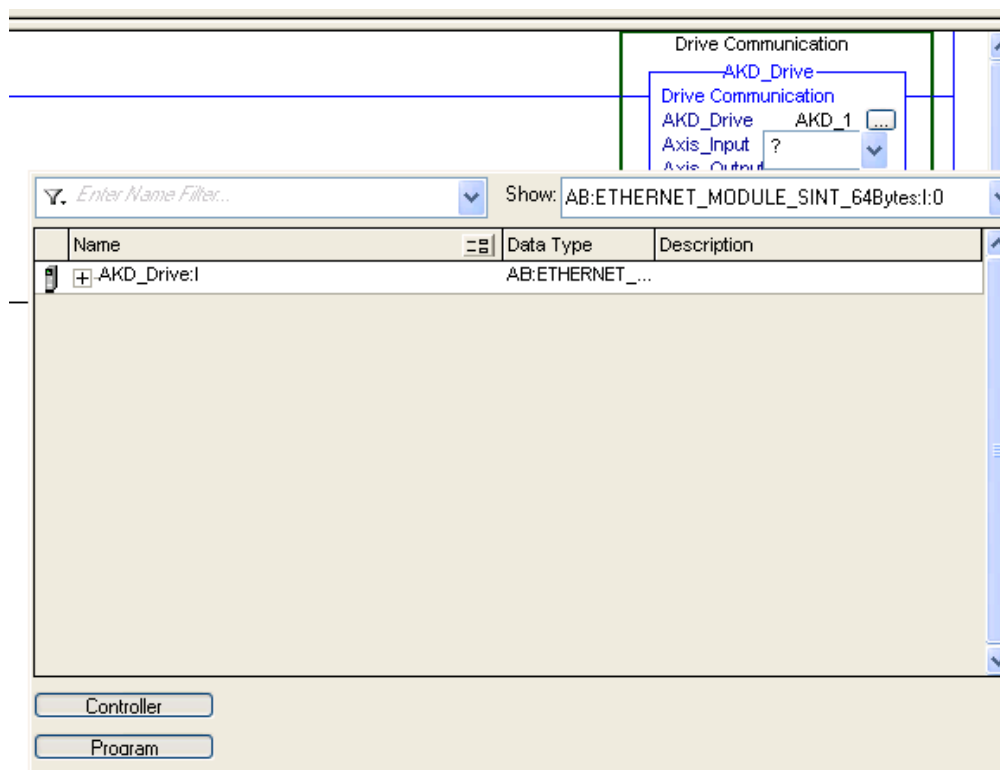

Figure 5-16: Adding Axis_Internal Parameter

5. Set the Axis_Input parameter to the input data of the axis for which you are setting up communication (Figure 5-18: Axis Communication Input). Double click the "?". A drop down box will appear. Select the input data tag that corresponds to the "ETHERNET-MODULE" object you created in the I/O Configuration of the project.

**Figure 5-17: Axis Communication Input**

6. Set the Axis_Output parameter to the output data of the axis for which you are setting up communication (Figure 5-18: Axis Communication Output). Double click the "?". A drop down box will appear. Select the output data tag that corresponds to the "ETHERNET-MODULE" object you created in the I/O Configuration of the project.

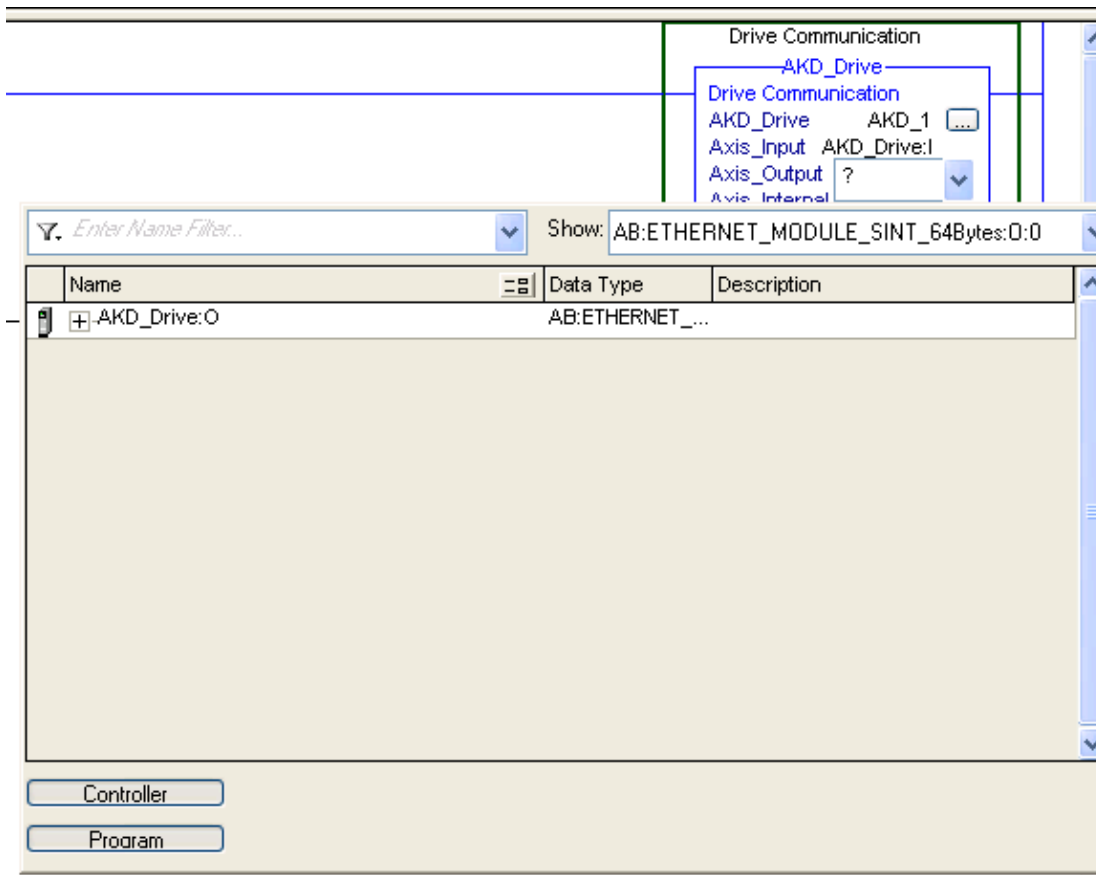

Figure 5-18: Axis Communication Output

7. Once you have configured the drive communication block, you should be able to use any of the other AKD Add-On instructions as you would the native RSLogix instructions.
8. Repeat steps 2-4 to add a new tag to the Axis_Internal parameter of the instruction, with a data type of AKD_Axis.
9. For more information on each instruction, see “Section 5: AKD Instructions” below.

5.4 Reading and Writing Drive Parameters

In addition to the Add-On instructions listed in this manual, almost all drive parameters can be read or set through the use of a MSG instruction.

Appendix B provides a list of parameters which are available.

5.4.1 Read Drive Parameter

To read a parameter, create a MSG instruction with the following settings:

Field	Value
Message Type	CIP Generic
Service Type	Parameter Read
Service Code	e (Hex)
Class	f (Hex)
Instance	Parameter Instance from Appendix B

Field	Value
Attribute	1
Destination	Create a tag to hold the value
Communication > Path	Name of the ETHERNET-MODULE for the AKD axis. Use the Browse button.

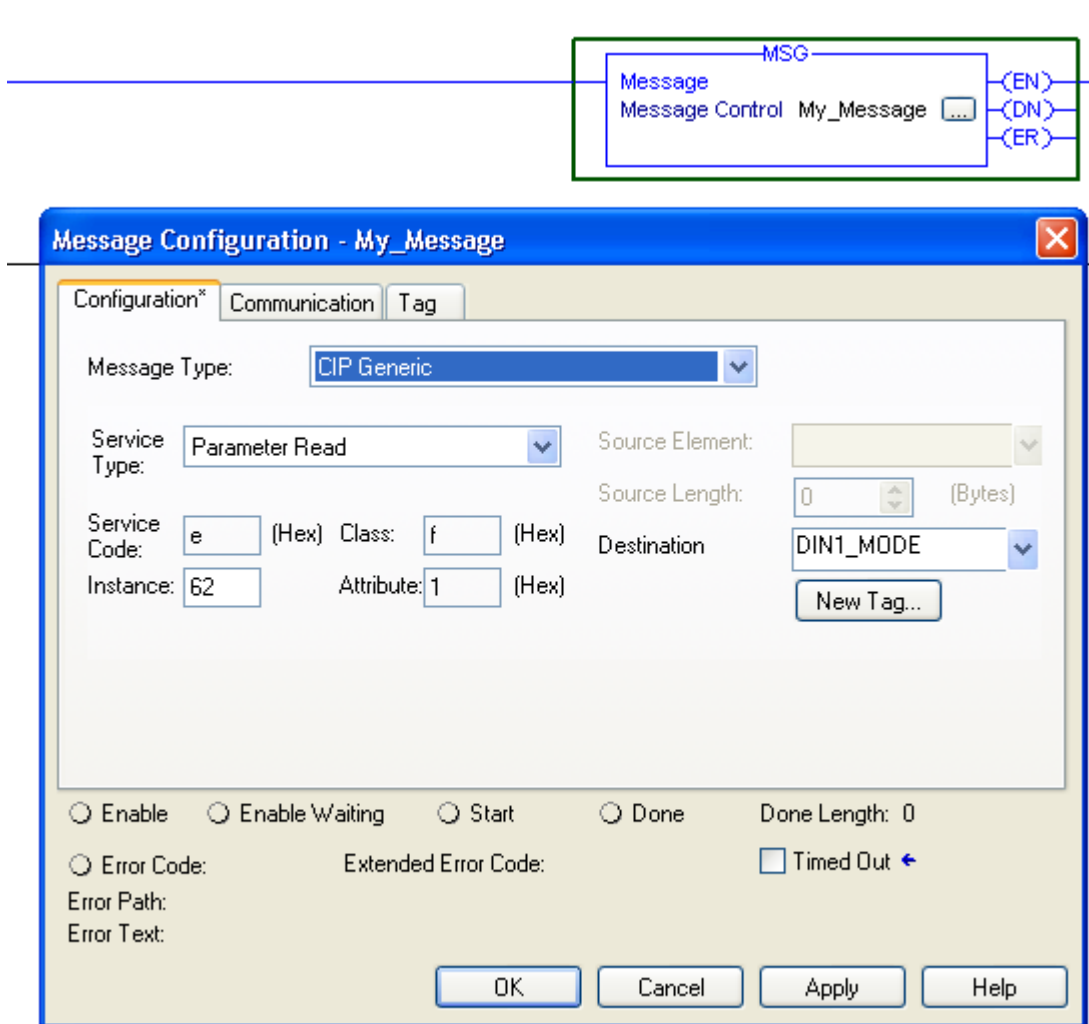

Figure 5-19: Message Configuration

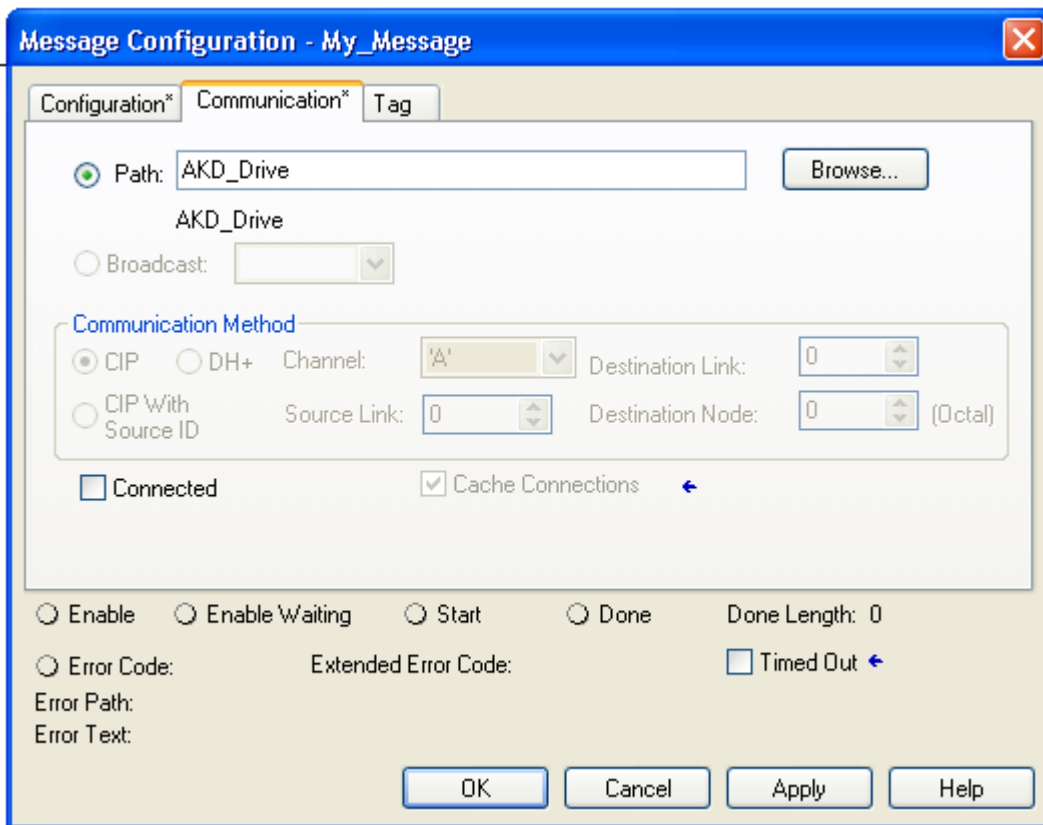

Figure 5-20: Message Configuration | Communication

5.4.2 Write Drive Parameter

To set a parameter, create a MSG instruction with the following settings:

Field	Value
Message Type	CIP Generic
Service Type	Parameter Write
Service Code	10 (Hex)
Class	f (Hex)
Instance	Parameter Instance from Appendix B
Attribute	1
Source Element	Create a tag to hold the value
Source Length	Parameter size from Appendix B
Communication > Path	Name of the ETHERNET-MODULE for the AKD axis. Use the Browse button.

5.4.3 Execute Drive Command Parameter

Some drive parameters are actually commands which do not take a value, but execute a drive function such as HOME.MOVE or DRV.CLEARFAULTS. To execute a command, create a MSG instruction to write to the command:

Field	Value
Message Type	CIP Generic
Service Type	Parameter Write
Service Code	10 (Hex)
Class	f (Hex)
Instance	Parameter Instance from Appendix B
Attribute	1
Source Element	Create a tag to hold the value. Any actual value may be used - it is ignored.
Source Length	1 byte
Communication > Path	Name of the ETHERNET-MODULE for the AKD axis. Use the Browse button.

6 AKD Instructions

The AKD Add-On Instructions are RSLogix instructions that define AKD drives and axis configurations. These instructions are made to be imported into an RSLogix5000 project. Once defined in a project, they function just as a native RSLogix Motion instruction. The add-on instructions are written to mirror the native instructions, leveraging existing knowledge of the software. The add-on instructions encapsulate the most commonly used logic for AKD axes. They provide easily reusable tools to operate drives and axes, promoting consistency across different projects. They provide easy control of I/O Assembly Messages. The native MSG instruction is used in RSLogix for sending Explicit Messages.

NOTE

Only one AKD add-on instruction can be enabled at a time in your project. The add-on instructions write to the same data structure (the Command Assembly) to set control bits and command motion. Trying to enable or execute two add-on instructions at one time would create a conflict for the control of the communication channel. Keep this in mind when writing programs that utilize these instructions.

6.1 Motion Axis Drive Communication (AKD_Drive)

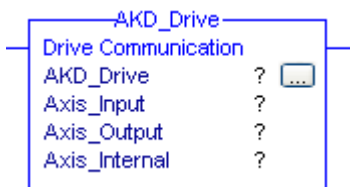

6.1.1 Description

Use the motion axis drive communication (AKD_Drive) instruction to initiate communication for an axis. This command is required for all other AKD commands to function properly.

6.1.2 Operands

Operand	Type	Format	Description
AKD_Drive	AKD_DRIVE	Tag	Control tag for this instruction.
Axis_Input	AB:ETHERNET_MODULE_SINT_8Bytes:I:0	Tag	Input memory space for axis.
Axis_Output	AB:ETHERNET_MODULE_SINT_8Bytes:O:0	Tag	Output memory space for axis.
Axis_Internal	AKD_AXIS	Tag	The name of the axis to initialize. This tag is an input parameter for all AKD instructions.

6.1.3 AKD_DRIVE Structure

Mnemonic	Data Type	Description
.EnableIn	BOOL	The enable input bit indicates that the instruction is enabled. It remains set until the instruction completes and the rung-condition-in goes false.
.EnableOut	BOOL	The enable output bit is the output of the enable input bit.

6.1.4 Execution

Condition	Ladder Diagram Action
Instruction execution	Read response message and send command message to axis.

6.1.5 Changes to Axis Status Bits

Bit Name	Meaning
All	All axis status bits are updated from drive.

6.2 Motion Axis On (AKD_Enable)

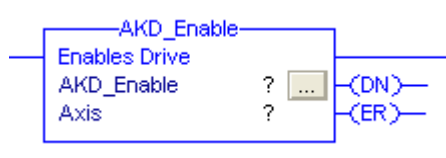

6.2.1 Description

The Motion Axis On (AKD_Enable) instruction directly activates the drive and enables the configured servo loops associated with a physical servo axis. It can be used anywhere in a program. Corresponds to the MSO instruction in Rockwell drives.

The AKD_Enable instruction automatically enables the specified axis by activating the drive and by activating the associated servo loop. The most common use of this instruction is to activate the servo loop for the specified axis in its current position in preparation for commanding motion.

NOTE

The AKD_Enable instruction execution may take multiple scans to execute because it requires transmission of a message to the motion module and time for the drive output to stabilize and the servo loop to activate. The Done (.DN) bit is not set immediately, but only after the axis is in the Enabled state.

6.2.2 Operands

Operand	Type	Format	Description
AKD_Enable	AKD_ENABLE	Tag	Control tag for this instruction.
Axis	AKD_AXIS	Tag	The name of the axis to enable.

6.2.3 AKD_ENABLE Structure

Mnemonic	Data Type	Description
.EnableIn	BOOL	The enable input bit indicates that the instruction is enabled. It remains set until the instruction completes and the rung-condition-in goes false.
.EnableOut	BOOL	The enable output bit is the output of the enable input bit.
.DN (Done)	BOOL	The done bit indicates when the enable instruction completes.
.ER (Error)	BOOL	The error bit indicates if the instruction detects an error.
.Axis	AKD_AXIS	The axis being enabled.

6.2.4 Execution

Condition	Ladder Diagram Action
Prescan	Initialize variables and clear timeout.
Rung-condition-in is false	Initialize variables and clear timeout.
Instruction execution	Set enable bit in the command message to the drive if the drive does not have any faults. Then, set the done bit when the enabled response is returned. If the drive has a general fault or there is a communication timeout, set the error bit.

6.2.5 Changes to Axis Status Bits

Bit Name	State	Meaning
Enable	True	Axis is in Enabled state with the servo loop active.

6.3 Motion Axis Off (AKD_Disable)

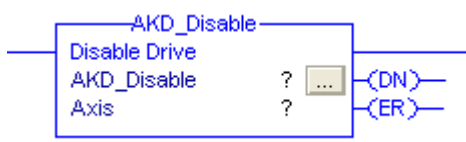

6.3.1 Description

The Motion Axis Off (AKD_Disable) instruction directly and immediately turns off drive output and disables the servo loop on any physical servo axis. This places the axis in the Disabled state. The AKD_Disable instruction also disables any motions that may be active at the time of execution. Corresponds to the MSF instruction in Rockwell drives.

The AKD_Disable instruction requires no parameters - simply enter the desired axis. Use the Tag Editor to create and configure a new axis.

You can use the AKD_Disable instruction to turn servo action OFF when you must move the axis by hand. Since the position continues to be tracked even with the servo action Off, when the servo loop is turned On again by the AKD_Enable instruction, the axis is again under closed-loop control, at the new position.

NOTE

The AKD_Disable instruction execution may take multiple scans to execute because it requires transmission of a message to the motion module and time for the drive output and servo loop to be fully deactivated. The Done (.DN) bit is not set until this message has been successfully transmitted and the axis transitions to the Disabled state.

6.3.2 Operands

Operand	Type	Format	Description
AKD_Disable	AKD_DISABLE	Tag	Control tag for this instruction.
Axis	AKD_AXIS	Tag	The name of the axis to disable.

6.3.3 AKD_DISABLE Structure

Mnemonic	Data Type	Description
.EnableIn	BOOL	The enable input bit indicates that the instruction is enabled. It remains set until the instruction completes and the rung-condition-in goes false.
.EnableOut	BOOL	The enable output bit is the output of the enable input bit.
.DN (Done)	BOOL	The done bit indicates when the disable instruction completes.
.ER (Error)	BOOL	The error bit indicates if the instruction detects an error.
.Axis	AKD_AXIS	The axis being disabled.

6.3.4 Execution

Condition	Ladder Diagram Action
Prescan	Initialize variables and clear timeout.
Rung-condition-in is false	Initialize variables and clear timeout.
Instruction execution	Reset enable bit in the command message to the drive. Then, set the done bit when the disabled response is returned. If the drive has a general fault or there is a communication timeout, set the error bit.

6.3.5 Changes to Axis Status Bits

Bit Name	State	Meaning
Enable	False	Axis is in Disabled state with the servo loop active.

6.4 Motion Axis Home (AKD_Home)

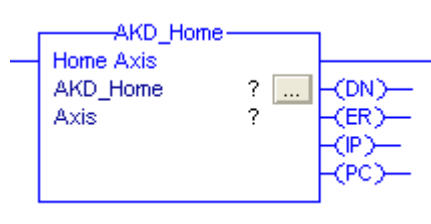

6.4.1 Description

The Motion Axis Home (AKD_Home) instruction triggers the axis to home using the currently configured homing mode. See the [WorkBench User Guide](#) for homing modes and setting instructions. This command triggers the drive to start the procedure and monitors for the process to complete. Similar to the MAH instruction in Rockwell drives.

Drive must be enabled in order to execute this instruction.

This is a transitional instruction:

- In ladder diagram, toggle the rung-condition-in from cleared to set each time the instruction should execute.

NOTE

The AKD_HOME instruction execution may take multiple scans to execute because it requires transmission of a message to the motion module and time for the drive to perform the homing procedure.

6.4.2 Operands

Operand	Type	Format	Description
AKD_Home	AKD_HOME	Tag	Control tag for this instruction.
Axis	AKD_AXIS	Tag	The name of the axis to home.

6.4.3 AKD_HOME Structure

Mnemonic	Data Type	Description
.EnableIn	BOOL	The enable input bit indicates that the instruction is enabled. It remains set until the instruction completes and the rung-condition-in goes false.
.EnableOut	BOOL	The enable output bit is the output of the enable input bit.
.DN (Done)	BOOL	The done bit indicates when the homing instruction completes.
.ER (Error)	BOOL	The error bit indicates if the instruction detects an error.
.IP (In Process)	BOOL	The in process bit is set when the command is enabled and remains true until the command completes or is terminated.
.PC (Process Complete)	BOOL	The process complete bit is set when the homing command has successfully completed.

6.4.4 Execution

Condition	Ladder Diagram Action
Prescan	Initialize variables and clear timeout.
Rung-condition-in is false	Initialize variables and clear timeout.
Instruction execution	Set the home command in the command message to the drive. Then, set the done bit when the command has initiated. The in process bit is set during execution and the process complete bit is set when the command has successfully completed. If the drive has a general fault or there is a communication timeout, set the error bit.

6.4.5 Changes to Axis Status Bits

Bit Name	State	Meaning
Home_Level	True	Level of home input.
Profile_In_Progress	True	Profile move is in progress (this bit may be set and cleared during instruction execution).

6.5 Motion Axis Jog (AKD_Jog)

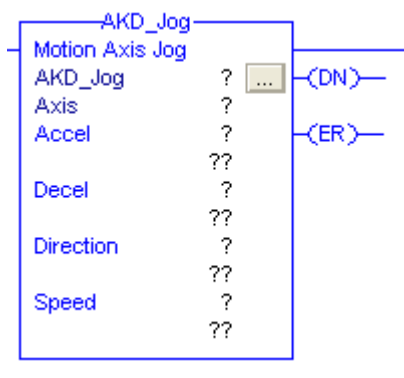

6.5.1 Description

Use the motion axis jog (AKD_Jog) instruction to move the axis at a constant speed until you tell it to stop. Corresponds to the MAJ instruction in Rockwell drives.

Drive must be enabled and in velocity or position mode in order to execute this instruction. A general status bit can be used to test if the jog motion is in progress.

6.5.2 Operands

Operand	Type	Format	Description	
AKD_Jog	AKD_JOG	Tag	Control tag for this instruction.	
Axis	AKD_AXIS	Tag	The name of the axis to enable.	
Accel	DINT	Immediate	Acceleration rate of the axis.	
Decel	DINT	Immediate	Deceleration rate of the axis.	
Direction	DINT	Immediate	For this jog direction: Enter:	
			Forward	1
			Reverse	0
Speed	DINT	Immediate	Speed to move the axis.	

6.5.3 AKD_JOG Structure

Mnemonic	Data Type	Description
.EnableIn	BOOL	The enable input bit indicates that the instruction is enabled. It remains set until the instruction completes and the rung-condition-in goes false.
.EnableOut	BOOL	The enable output bit is the output of the enable input bit.
.DN (Done)	BOOL	The done bit indicates when the jog instruction is successfully initiated.
.ER (Error)	BOOL	The error bit indicates if the instruction detects an error.

6.5.4 Programming Guidelines

Guideline	Details
In ladder diagram, toggle the rung condition each time you want to execute the instruction.	This is a transitional instruction. In ladder diagram, toggle the rung-condition-in from cleared to set each time you want to execute the instruction.
Use an AKD_Stop_Smooth instruction to stop the jog.	See the AKD_Stop_Smooth instruction for more details.

6.5.5 Execution

Condition	Ladder Diagram Action
Prescan	Initialize variables and clear timeout.
Rung-condition-in is false	Reset in progress bit when axis profile is no longer in progress.
Instruction execution	Send smooth stop to axis. Set the in progress bit to indicate that the command has initiated successfully and command is running. Set the done bit when the axis has stopped moving. If a general fault occurs, set the error bit.

6.5.6 Changes to Axis Status Bits

Bit Name	State	Meaning
Current_Direction	<Input Defined>	Velocity mode direction (False = Reverse, True = Forward) set based on parameter input.
Profile_In_Progress	True	Profile move is in progress.

6.6 Motion Axis Move (AKD_Move)

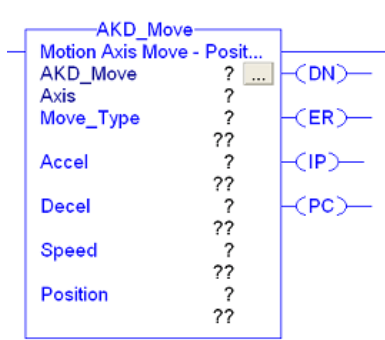

6.6.1 Description

Use the motion axis move (AKD_Move) instruction to move an axis to a specified relative or absolute position. Corresponds to the MAM instruction in Rockwell drives.

Drive must be enabled, homed, and in position mode in order to execute this instruction.

6.6.2 Operands

Operand	Type	Format	Description	
AKD_Move	AKD_MOVE	Tag	Control tag for this instruction.	
Axis	AKD_AXIS	Tag	The name of the axis to enable.	
Move Type	SINT	Immediate	For this move mode	
			Absolute	Enter: 0
			Relative to Command Position	1
Accel	DINT	Immediate	Acceleration rate of the axis.	
Decel	DINT	Immediate	Deceleration rate of the axis.	
Speed	DINT	Immediate	Speed to move the axis.	
Position	DINT	Immediate	Target position for move.	

6.6.3 AKD_MOVE Structure

Mnemonic	Data Type	Description
.EnableIn	BOOL	The enable input bit indicates that the instruction is enabled. It remains set until the instruction completes and the rung-condition-in goes false.
.EnableOut	BOOL	The enable output bit is the output of the enable input bit.
.DN (Done)	BOOL	The done bit indicates when the move instruction is successfully initiated.
.ER (Error)	BOOL	The error bit indicates if the instruction detects an error.
.IP (In Process)	BOOL	The in process bit is set when the command is enabled and remains true until the move completes or is terminated.
.PC (Process Complete)	BOOL	The process complete bit is set when the command is complete.

6.6.4 Programming Guidelines

Guideline	Details
In ladder diagram, toggle the rung condition each time you want to execute the instruction.	This is a transitional instruction. In ladder diagram, toggle the rung-condition-in from cleared to set each time you want to execute the instruction.
Use the AKD_Move instruction to change one that is already in progress.	You can change the position target, speed, acceleration, or deceleration limits and the change will take place immediately. The axis will move to the updated position, possibly even changing direction, without stopping at the old end position.

6.6.5 Choosing a Move Type

See the [WorkBench Online Help](#) for more information on position move types.

6.6.6 Execution

Condition	Ladder Diagram Action
Prescan	Initialize variables and clear timeout.
Rung-condition-in is false	Reset in process bit when axis profile is no longer in progress. Set process complete bit when move command successfully completes.
Instruction execution	Reset done and error bits, then set accel, decel, speed, and position. Start move and set the done bit to indicate command started and set the in process bit to indicate that the command is running. If the motion stops, clear the in process bit. Set process complete bit when move command successfully completes. If a general fault occurs or there is a communication response timeout, set the error bit.

6.6.7 Changes to Axis Status Bits

Bit Name	State	Meaning
Profile_In_Progress	True	Profile move is in progress.
On_Target_Position	True	True once current position equals last target position.

6.7 Motion Axis Set Home Mode (AKD_Set_Home_Mode)

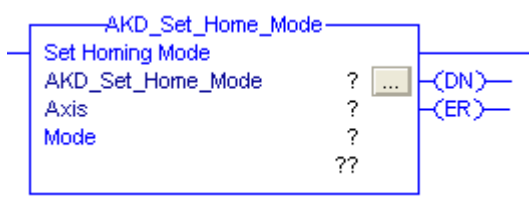

6.7.1 Description

Use the motion axis set home mode (AKD_Set_Home_Mode) instruction to set the homing mode used by the drive when the AKD_Home command is called.

NOTE

The AKD_Set_Home_Mode instruction execution may take multiple scans to execute because it requires transmission of a message to the motion module. The Done (.DN) bit is not set immediately, but only after the home mode is set.

This is a transitional instruction:

- In ladder diagram, toggle the rung-condition-in from cleared to set each time the instruction should execute.

6.7.2 Operands

Operand	Type	Format	Description
AKD_Set_Home_Mode	AKD_SET_HOME_MODE	Tag	Control tag for this instruction.
Axis	AKD_AXIS	Tag	The name of the axis to modify.

Operand	Type	Format	Description	
Mode	SINT	Immediate	For Mode	Enter:
			Current Position	0
			Limit Input	1
			Limit/Zero Angle	2
			Limit/Index	3
			Home Input	4
			Home/Zero Angle	5
			Home/Index	6
			Zero Angle	7
			Position Error	8
			Position Error/Zero Angle	9
			Position Error/Index	10
			Index	11
Home OR Position Error	12			

6.7.3 AKD_SET_HOME_MODE Structure

Mnemonic	Data Type	Description
.EnableIn	BOOL	The enable input bit indicates that the instruction is enabled. It remains set until the instruction completes and the rung-condition-in goes false.
.EnableOut	BOOL	The enable output bit is the output of the enable input bit.
.DN (Done)	BOOL	The done bit indicates when the mode is successfully set.
.ER (Error)	BOOL	The error bit indicates if the instruction detects an error.

6.7.4 Homing Modes

See the [WorkBench Online Help](#) for a full description of each homing mode. This value corresponds to the drive parameter HOME.MODE.

6.7.5 Execution

Condition	Ladder Diagram Action
Prescan	Initialize variables and clear timeout.
Rung-condition-in is false	Initialize variables and clear timeout.
Instruction execution	Reset the done and error bits and set homing mode when instruction is enabled. Set done bit when axis homing mode is set. If a general fault occurs or there is a communication response timeout, set the error bit.

6.7.6 Changes to Axis Status Bit

Bit Name	State	Meaning
(none)		

6.8 Motion Axis Set Acceleration (AKD_Set_Accel)

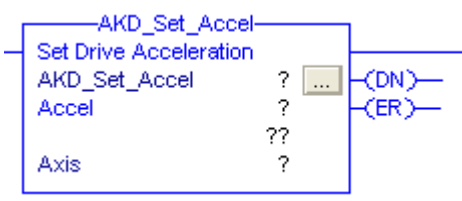

6.8.1 Description

Use the motion axis set acceleration (AKD_Set_Accel) instruction to set the axis acceleration parameter used with axis moves.

NOTE

The AKD_Set_Accel instruction execution may take multiple scans to execute because it requires transmission of a message to the motion module. The Done (.DN) bit is not set immediately, but only after the acceleration is set.

This is a transitional instruction. In ladder diagram, toggle the rung-condition-in from cleared to set each time the instruction should execute.

6.8.2 Operands

Operand	Type	Format	Description
AKD_Set_Accel	AKD_SET_ACCEL	Tag	Control tag for this instruction.
Axis	AKD_AXIS	Tag	The name of the axis to modify.
Accel	DINT	Immediate	Acceleration parameter for axis moves.

6.8.3 AKD_SET_ACCEL Structure

Mnemonic	Data Type	Description
.EnableIn	BOOL	The enable input bit indicates that the instruction is enabled. It remains set until the instruction completes and the rung-condition-in goes false.
.EnableOut	BOOL	The enable output bit is the output of the enable input bit.
.DN (Done)	BOOL	The done bit indicates when the acceleration is successfully set.
.ER (Error)	BOOL	The error bit indicates if the instruction detects an error.

6.8.4 Execution

Condition	Ladder Diagram Action
Prescan	Initialize variables and clear timeout.
Rung-condition-in is false	Initialize variables and clear timeout.
Instruction execution	Reset done and error bits and send acceleration command when instruction is enabled. Set done bit when axis command response received. If a general fault occurs or there is a communication response timeout, set the error bit.

6.8.5 Changes to Axis Status Bits

Bit Name	State	Meaning
(none)		

6.9 Motion Axis Set Deceleration (AKD_Set_Decel)

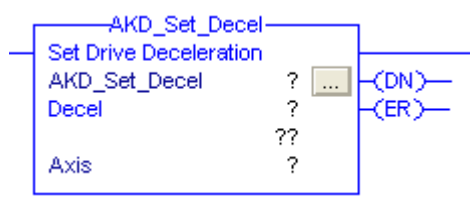

6.9.1 Description

Use the motion axis set deceleration (AKD_Set_Decel) instruction to set the axis deceleration parameter used with axis moves.

NOTE

The AKD_Set_Decel instruction execution may take multiple scans to execute because it requires transmission of a message to the motion module. The Done (.DN) bit is not set immediately, but only after the deceleration is set.

This is a transitional instruction. In ladder diagram, toggle the rung-condition-in from cleared to set each time the instruction should execute.

6.9.2 Operands

Operand	Type	Format	Description
AKD_Set_Decel	AKD_SET_DECEL	Tag	Control tag for this instruction.
Axis	AKD_AXIS	Tag	The name of the axis to modify.
Decel	DINT	Immediate	Deceleration parameter for axis moves.

6.9.3 AKD_SET_DECEL Structure

Mnemonic	Data Type	Description
.EnableIn	BOOL	The enable input bit indicates that the instruction is enabled. It remains set until the instruction completes and the rung-condition-in goes false.
.EnableOut	BOOL	The enable output bit is the output of the enable input bit.
.DN (Done)	BOOL	The done bit indicates when the deceleration is successfully set.
.ER (Error)	BOOL	The error bit indicates if the instruction detects an error.

6.9.4 Execution

Condition	Ladder Diagram Action
Prescan	Initialize variables and clear timeout.
Rung-condition-in is false	Initialize variables and clear timeout.
Instruction execution	Reset done and error bits and send deceleration command when instruction is enabled. Set done bit when axis command response received. If a general fault occurs or there is a communication response timeout, set the error bit.

6.9.5 Changes to Axis Bits

Bit Name	State	Meaning
(none)		

6.10 Motion Axis Set Mode (AKD_Set_Mode)

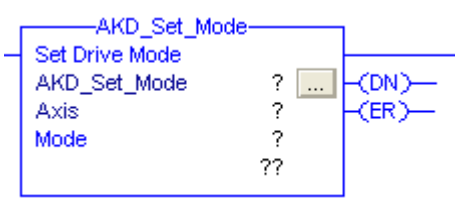

6.10.1 Description

Use the motion axis set mode (AKD_Set_Mode) instruction to set the operation mode for the axis' servo loop control.

NOTE

The AKD_Set_Mode instruction execution may take multiple scans to execute because it requires transmission of a message to the motion module. The Done (.DN) bit is not set immediately, but only after the mode is set.

This is a transitional instruction:

- In ladder diagram, toggle the rung-condition-in from cleared to set each time the instruction should execute.

6.10.2 Operands

Operand	Type	Format	Description	
AKD_Set_Mode	AKD_SET_MODE	Tag	Control tag for this instruction.	
Axis	AKD_AXIS	Tag	The name of the axis to modify.	
Move Type	SINT	Immediate	For Mode*	Enter:
			Position	2
			Velocity	1
			Torque	0

* The operation modes definition follows the AKD specification (not the CIP standard definition).

6.10.3 AKD_SET_MODE Structure

Mnemonic	Data Type	Description
.EnableIn	BOOL	The enable input bit indicates that the instruction is enabled. It remains set until the instruction completes and the rung-condition-in goes false.
.EnableOut	BOOL	The enable output bit is the output of the enable input bit.
.DN (Done)	BOOL	The done bit indicates when the mode is successfully set.
.ER (Error)	BOOL	The error bit indicates if the instruction detects an error.

6.10.4 Operation Modes

Mode	Description
Position (2)	Axis will operate to match current position to target position.
Velocity (1)	Axis will operate to match current velocity to target velocity.
Torque (0)	Axis will operate to match current torque to target torque.

6.10.5 Execution

Condition	Ladder Diagram Action
Prescan	Initialize variables and clear timeout.
Rung-condition-in is false	Initialize variables and clear timeout.
Instruction execution	Reset done and error bits and send mode command when instruction is enabled. Set done bit when axis command response received. If a general fault occurs or there is a communication response timeout, set the error bit.

6.10.6 Changes to Axis Status Bits

Bit Name	State	Meaning
(none)		

6.11 Motion Axis Set Position (AKD_Set_Position)

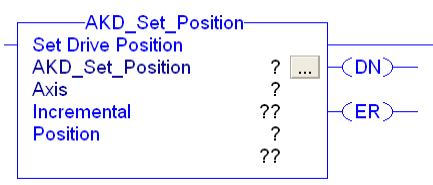

6.11.1 Description

Use the motion axis set position (AKD_Set_Position) instruction to set an axis' position target for the servo position control mode loop.

NOTE

The AKD_Set_Position instruction initiates axis motion the same as the AKD_Move instruction. It is recommended to use AKD_Set_Position instruction only for updating the target position of a move already in progress or for repeating the previous move with a new target position. Use the AKD_Move for all other position motion.

To successfully execute an AKD_Set_Position instruction, the drive must be enabled, homed, and in position mode.

NOTE

The AKD_Set_Position instruction execution may take multiple scans to execute because it requires transmission of a message to the motion module. The Done (.DN) bit is not set immediately, but only after the position is set.

This is a transitional instruction:

- In ladder diagram, toggle the rung-condition-in from cleared to set each time the instruction should execute.

6.11.2 Operands

Operand	Type	Format	Description	
AKD_Set_Position	AKD_SET_POSITION	Tag	Control tag for this instruction.	
Axis	AKD_AXIS	Tag	The name of the axis to modify.	
Incremental	BOOL	Immediate	For this position value Enter:	
			Absolute	0
			Incremental	1
Position	DINT	Immediate	Position value for axis position control loop.	

6.11.3 AKD_SET_POSITION Structure

Mnemonic	Data Type	Description
.EnableIn	BOOL	The enable input bit indicates that the instruction is enabled. It remains set until the instruction completes and the rung-condition-in goes false.
.EnableOut	BOOL	The enable output bit is the output of the enable input bit.
.DN (Done)	BOOL	The done bit indicates when the position is successfully set.
.ER (Error)	BOOL	The error bit indicates if the instruction detects an error.

6.11.4 Execution

Condition	Ladder Diagram Action
Prescan	Initialize variables and clear timeout.
Rung-condition-in is false	Initialize variables and clear timeout.
Instruction execution	Reset done and error bits and send position command when instruction is enabled. Set done bit when axis command response received. If a general fault occurs or there is a communication response timeout, set the error bit.

6.11.5 Changes to Axis Status Bits

Bit Name	State	Meaning
Profile_In_Progress	True	Profile move is in progress.
On_Target_Position	True	True once current position equals last target position.

6.12 Motion Axis Set Velocity (AKD_Set_Velocity)

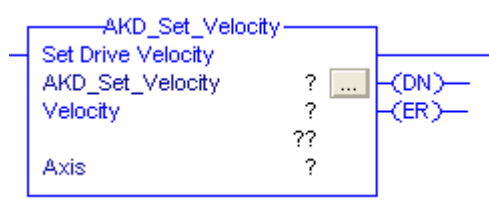

6.12.1 Description

Use the motion axis set velocity (AKD_Set_Velocity) instruction to set an axis' velocity setpoint for the servo control loop.

NOTE

The AKD_Set_Velocity instruction initiates axis motion the same as the AKD_Jog instruction, when in velocity mode. It is recommended to use AKD_Set_Velocity instruction only for updating the target speed of a jog already in progress and the AKD_Jog for all other constant speed motion.

To successfully execute an AKD_Set_Velocity instruction, the drive must be enabled, homed, and in velocity mode.

NOTE

The AKD_Set_Velocity instruction execution may take multiple scans to execute because it requires transmission of a message to the motion module. The Done (.DN) bit is not set immediately, but only after the velocity is set.

This is a transitional instruction:

- In ladder diagram, toggle the rung-condition-in from cleared to set each time the instruction should execute.

6.12.2 Operands

Operand	Type	Format	Description
AKD_Set_Velocity	AKD_SET_VELOCITY	Tag	Control tag for this instruction.
Axis	AKD_AXIS	Tag	The name of the axis to modify.
Velocity	DINT	Immediate	Set velocity for axis control loop.

6.12.3 AKD_SET_VELOCITY Structure

Mnemonic	Data Type	Description
.EnableIn	BOOL	The enable input bit indicates that the instruction is enabled. It remains set until the instruction completes and the rung-condition-in goes false.
.EnableOut	BOOL	The enable output bit is the output of the enable input bit.
.DN (Done)	BOOL	The done bit indicates when the velocity is successfully set.
.ER (Error)	BOOL	The error bit indicates if the instruction detects an error.

6.12.4 Execution

Condition	Ladder Diagram Action
Prescan	Initialize variables and clear timeout.
Rung-condition-in is false	Initialize variables and clear timeout.
Instruction execution	Reset done and error bits and send velocity command when instruction is enabled. Set done bit when axis command response received. If a general fault occurs or there is a communication response timeout, set the error bit.

6.12.5 Changes to Axis Status Bits

Bit Name	State	Meaning
Profile_In_Progress	True	Profile move is in progress.
On_Target_Position	True	True once current position equals last target position.

6.13 Motion Axis Shutdown (AKD_Shutdown)

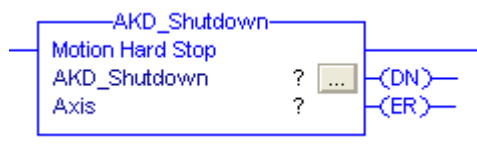

6.13.0.1 Description

The motion axis shutdown (AKD_Shutdown) instruction executes a controlled stop, then disables the servo loop, disables drive output, and places the axis into the Shutdown state. This instruction is also referred to as a hard stop. The shutdown state disables the drive output and deactivates the servo loop.

Another action initiated by the AKD_Shutdown instruction is the clearing of all motion processes in progress and the clearing of all the motion status bits. Associated with this action, the command also clears all motion instruction IP bits that are currently set for the targeted axis.

Another characteristic of the Shutdown state is that any instruction that initiates axis motion is blocked from execution. Attempts to do so result in an execution error. By executing the Shutdown Reset instruction or disabling and re-enabling the drive motion can be successfully initiated again.

The axis will remain in the shutdown state until a Motion Axis Shutdown Reset (AKD_Shutdown_Reset) instruction executes or the drive is disabled and re-enabled. Corresponds to the MASD instruction in Rockwell drives.

NOTE

The AKD_Shutdown instruction execution may take multiple scans to execute because it requires transmission of a message to the motion module. The Done (.DN) bit is not set immediately, but only after the shutdown is set.

This is a transitional instruction:

- In ladder diagram, toggle the rung-condition-in from cleared to set each time the instruction should execute.

6.13.1 Operands

Operand	Type	Format	Description
AKD_Shutdown	AKD_SHUTDOWN	Tag	Control tag for this instruction.
Axis	AKD_AXIS	Tag	The name of the axis to shut down.

6.13.2 AKD_SHUTDOWN Structure

Mnemonic	Data Type	Description
.EnableIn	BOOL	The enable input bit indicates that the instruction is enabled. It remains set until the instruction completes and the rung-condition-in goes false.
.EnableOut	BOOL	The enable output bit is the output of the enable input bit.
.DN (Done)	BOOL	The done bit indicates when the axis is successfully shutdown.
.ER (Error)	BOOL	The error bit indicates if the instruction detects an error.

6.13.3 Execution

Condition	Ladder Diagram Action
rung-condition-in is false	Clears hard stop command.
instruction execution	Send hard stop command when instruction is enabled. Set done bit when profile in progress is cleared. If a general fault occurs set the error bit.

6.13.4 Changes to Axis Status Bits

Bit Name	State	Meaning
Profile_In_Progress	True	No move is in progress
Enable	True	Axis is in Disabled state with the servo loop inactive.

6.14 Motion Axis Shutdown Reset (AKD_Shutdown_Reset)



6.14.1 Description

Use the motion axis shutdown reset (AKD_Shutdown_Reset) instruction to transition an axis from the Shutdown state to the Disabled ready state. All faults associated with the specified axis are automatically cleared. Corresponds to the MASR instruction in Rockwell drives.

NOTE

The AKD_Shutdown_Reset instruction execution may take multiple scans to execute because it requires transmission of a message to the motion module and time for the drive to execute the command. The Done (.DN) bit is not set immediately, but only after the drive is reset.

This is a transitional instruction:

- In ladder diagram, toggle the rung-condition-in from cleared to set each time the instruction should execute.

6.14.2 Operands

Operand	Type	Format	Description
AKD_Shutdown_Reset	AKD_SHUTDOWN_RESET	Tag	Control tag for this instruction.
Axis	AKD_AXIS	Tag	The name of the axis to reset.

6.14.3 AKD_SHUTDOWN_RESET Structure

Mnemonic	Data Type	Description
.EnableIn	BOOL	The enable input bit indicates that the instruction is enabled. It remains set until the instruction completes and the rung-condition-in goes false.
.EnableOut	BOOL	The enable output bit is the output of the enable input bit.
.DN (Done)	BOOL	The done bit indicates when the axis is successfully reset.
.ER (Error)	BOOL	The error bit indicates if the instruction detects an error.

6.14.4 Execution

Condition	Ladder Diagram Action
Prescan	Initialize variables and clear timeout.
Rung-condition-in is false	Initialize variables and clear timeout.
Instruction execution	Reset done and error bits, disable axis, and reset faults. Set done bit when all axis command responses received. If a general fault occurs or there is a communication response timeout, set the error bit.

6.14.5 Changes to Axis Status Bits

Bit Name	State	Meaning
General_Fault	False	No general fault is present.
Enable	False	Axis is disabled.
FE_Fault	False	No following error fault is present.
Block_Fault	False	No block execution fault is present.

6.15 Motion Axis Smooth Stop (AKD_Stop_Smooth)

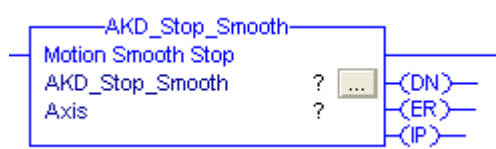

6.15.1 Description

Use the motion axis smooth stop (AKD_Stop_Smooth) instruction to end any controlled motion in process for the axis with a decelerated stop. The instruction stops the motion without disabling the servo loop. This command defaults to stop at the deceleration rate set for the current motion. Corresponds to the MAS instruction in Rockwell drives.

Use the instruction to:

- Stop a specific motion process such as jogging or moving
- Stop the axis completely

NOTE

The AKD_Stop_Smooth instruction execution may take multiple scans to execute because it requires transmission of a message to the motion module and time for the drive to execute the command. The Done (.DN) bit is set once the motion stops.

6.15.2 Operands

Operand	Type	Format	Description
AKD_Stop_Smooth	AKD_STOP_SMOOTH	Tag	Control tag for this instruction.
Axis	AKD_AXIS	Tag	The name of the axis to stop.

6.15.3 AKD_STOP_SMOOTH Structure

Mnemonic	Data Type	Description
.EnableIn	BOOL	The enable input bit indicates that the instruction is enabled. It remains set until the instruction completes and the rung-condition-in goes false.
.EnableOut	BOOL	The enable output bit is the output of the enable input bit.
.DN (Done)	BOOL	The done bit indicates when the stop command has completed and the motion has stopped.
.ER (Error)	BOOL	The error bit indicates if the instruction detects an error.
.IP (In Process)	BOOL	The in process bit is set when the command is enabled and remains true until the stop is complete.

6.15.4 Execution

Condition	Ladder Diagram Action
Rung-condition-in is false	Initialize variables.
Instruction execution	Send smooth stop to axis. Set done bit when axis command is sent. If a general fault occurs, set the error bit.

6.15.5 Changes to Axis Status Bits

Bit Name	State	Meaning
Profile_In_Progress	False	No profile move executing.

6.16 Motion Axis Get Position Controller Attribute (AKD_Get_Attribute)

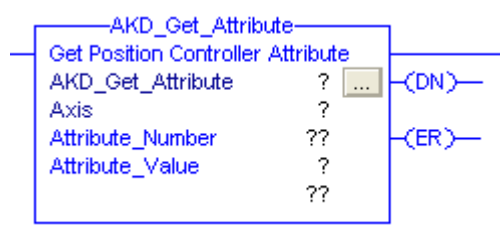

6.16.1 Description

Use the motion axis get attribute (AKD_Get_Attribute) instruction to query a Position Controller attribute from an axis. This instruction provides quick access to a special set of drive parameters which can always be accessed in one communication cycle. The output value will be updated with live values each cycle as long as this instruction is enabled.

NOTE

This instruction must not be enabled at the same time as the AKD_Get_Parameter instruction.

See Appendix A for a list of available attributes and numbering.

6.16.2 Operands

Operand	Type	Format	Description
AKD_Get_Attribute	AKD_GET_ATTRIBUTE	Tag	Control tag for this instruction.
Axis	AKD_AXIS	Tag	The name of the axis to query.
Attribute_Number	INT	Immediate	See Appendix A
Attribute_Value	DINT	Tag	Output tag to which the value of the attribute is passed.

6.16.3 AKD_GET_ATTRIBUTE Structure

Mnemonic	Data Type	Description
.EnableIn	BOOL	The enable input bit indicates that the instruction is enabled. It remains set until the instruction completes and the rung-condition-in goes false.
.EnableOut	BOOL	The enable output bit is the output of the enable input bit.
.DN (Done)	BOOL	The done bit indicates when the get attribute command has been completed.
.ER (Error)	BOOL	The error bit indicates if the instruction detects an error.

6.16.4 Execution

Condition	Ladder Diagram Action
Pre-scan	Initialize variables and clear timeout.
Rung-condition-in is false	Initialize variables and clear timeout.
Instruction execution	Send command to axis to request value. Set done bit and copy response to attribute value output when axis response is received. If a general fault or timeout occurs, set the error bit.

6.16.5 Changes to Axis Status Bits

Bit Name	State	Meaning
(none)		

6.17 Motion Axis Get Parameter (AKD_Get_Parameter)

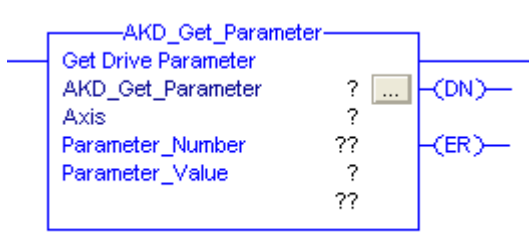

6.17.1 Description

Use the motion axis get parameter (AKD_Get_Parameter) instruction to query a drive parameter from an axis. The length of time to return the value is highly dependent on the particular parameter. The value will be latched when the instruction is done. Clear and re-enable the instruction to get an updated value.

6.17.2 Operands

Operand	Type	Format	Description
AKD_Get_Parameter	AKD_GET_PARAMETER	Tag	Control tag for this instruction.
Axis	AKD_AXIS	Tag	The name of the axis to query.
Parameter_Number	INT	Immediate	See Appendix B
Parameter_Value	DINT	Immediate	Output tag to which the value of the parameter is passed.

6.17.3 AKD_GET_PARAMETER Structure

Mnemonic	Data Type	Description
.EnableIn	BOOL	The enable input bit indicates that the instruction is enabled. It remains set until the instruction completes and the rung-condition-in goes false.
.EnableOut	BOOL	The enable output bit is the output of the enable input bit.
.DN (Done)	BOOL	The done bit indicates when the get parameter command has been completed.
.ER (Error)	BOOL	The error bit indicates if the instruction detects an error.

6.17.4 Execution

Condition	Ladder Diagram Action
Pre-scan	Initialize variables and clear timeout.
Rung-condition-in is false	Initialize variables and clear timeout.
Instruction execution	Send command to axis to request value. Set done bit and copy response to parameter value output when axis response is received. If a general fault or timeout occurs, set the error bit.

6.17.5 Changes to Axis Status Bits

Bit Name	State	Meaning
(none)		

6.18 Motion Axis Set Position Controller Attribute (AKD_Set_Attribute)

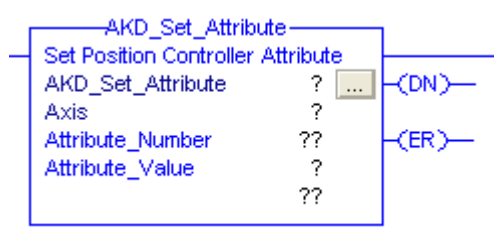

6.18.1 Description

Use the motion axis set attribute (AKD_Set_Attribute) instruction to set a Position Controller attribute for an axis. This instruction provides quick access to a special set of drive parameters which can always be set in one communication cycle. See Appendix A for a list of available attributes and numbering.

6.18.2 Operands

Operand	Type	Format	Description
AKD_Set_Attribute	AKD_SET_ATTRIBUTE	Tag	Control tag for this instruction.
Axis	AKD_AXIS	Tag	The name of the axis to modify.
Attribute_Number	INT	Immediate	See Appendix A
Attribute_Value	DINT	Immediate	Value to which the specified attribute will be set.

6.18.3 AKD_SET_ATTRIBUTE Structure

Mnemonic	Data Type	Description
.EnableIn	BOOL	The enable input bit indicates that the instruction is enabled. It remains set until the instruction completes and the rung-condition-in goes false.
.EnableOut	BOOL	The enable output bit is the output of the enable input bit.
.DN (Done)	BOOL	The done bit indicates when the set attribute command has been completed.
.ER (Error)	BOOL	The error bit indicates if the instruction detects an error.

6.18.4 Execution

Condition	Ladder Diagram Action
Pre-scan	Initialize variables and clear timeout.
Rung-condition-in is false	Initialize variables and clear timeout.
Instruction execution	Send command to axis to set value. Set done bit when axis response is received. If a general fault or timeout occurs, set the error bit.

6.18.5 Changes to Axis Status Bits

Bit Name	State	Meaning
(none)		

6.19 Motion Axis Set Parameter (AKD_Set_Parameter)

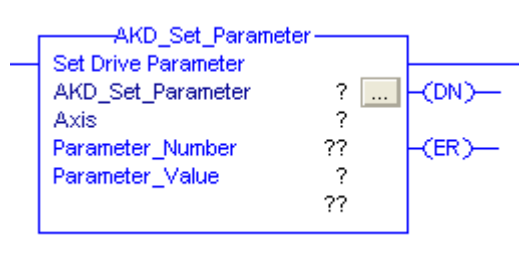

6.19.1 Description

Use the motion axis set parameter (AKD_Set_Parameter) instruction to modify a drive parameter or execute a drive command on an axis. The time required to execute the command is highly dependent on the particular parameter. See Appendix B for a list of available parameters and numbering.

6.19.2 Operands

Operand	Type	Format	Description
AKD_Set_Parameter	AKD_SET_PARAMETER	Tag	Control tag for this instruction.
Axis	AKD_AXIS	Tag	The name of the axis to modify.
Parameter_Number	INT	Immediate	(See Appendix B: AKD Parameters)
Parameter_Value	DINT	Immediate	Value to which the specified parameter will be set.

6.19.3 AKD_SET_PARAMETER Structure

Mnemonic	Data Type	Description
.EnableIn	BOOL	The enable input bit indicates that the instruction is enabled. It remains set until the instruction completes and the rung-condition-in goes false.
.EnableOut	BOOL	The enable output bit is the output of the enable input bit.
.DN (Done)	BOOL	The done bit indicates when the set parameter command has been completed.
.ER (Error)	BOOL	The error bit indicates if the instruction detects an error.

6.19.4 Execution

Condition	Ladder Diagram Action
Pre-scan	Initialize variables and clear timeout.
Rung-condition-in is false	Initialize variables and clear timeout.
Instruction execution	Send command to axis to set value. Set done bit when axis response is received. If a general fault or timeout occurs, set the error bit.

6.19.5 Changes to Axis Status Bits

Bit Name	State	Meaning
(none)		

6.20 Motion Axis Set Units (AKD_Set_Units)

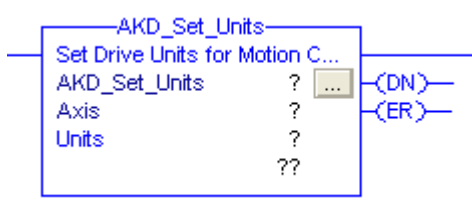

6.20.1 Description

Use the motion axis set units (AKD_Set_Units) instruction to set the current unit system used on an axis.

At the moment, only mode 0 (EIP.POSUNIT=65536 and EIP.PROFUNIT=65536) is available. These scaling values can also be modified directly through EtherNet/IP or WorkBench. See the AKD EtherNet/IP User Manual for more information about unit scaling.

6.20.2 Operands

Operand	Type	Format	Description	
AKD_Set_Units	AKD_SET_UNITS	Tag	Control tag for this instruction.	
Axis	AKD_AXIS	Tag	The name of the axis to modify.	
Units	SINT	Immediate	For units	Enter:
			Counts	0

6.20.3 AKD_SET_UNITS Structure

Mnemonic	Data Type	Description
.EnableIn	BOOL	The enable input bit indicates that the instruction is enabled. It remains set until the instruction completes and the rung-condition-in goes false.
.EnableOut	BOOL	The enable output bit is the output of the enable input bit.
.DN (Done)	BOOL	The done bit indicates when the set units command has been completed.
.ER (Error)	BOOL	The error bit indicates if the instruction detects an error.

6.20.4 Execution

Condition	Ladder Diagram Action
Pre-scan	Initialize variables and clear timeout.
Rung-condition-in is false	Initialize variables and clear timeout.
Instruction execution	Send command to axis to set units and if necessary update settings. Set done bit when axis response is received. If a general fault or timeout occurs, set the error bit.

6.20.5 Changes to Axis Status Bits

Bit Name	State	Meaning
(none)		

6.21 Motion Axis Torque (AKD_Torque_Move)

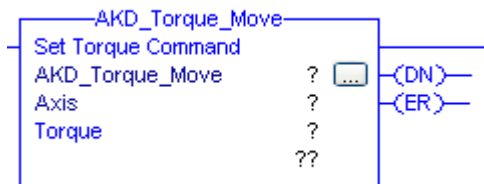

6.21.1 Description

Use the AKD_Torque_Move instruction to move an axis at a constant torque without regard to position.

Drive must be enabled and in torque mode in order to execute this instruction.

NOTE

The AKD_Shutdown_Reset instruction execution may take multiple scans to execute because it requires transmission of a message to the motion module and time for the drive to execute the command. The Done (.DN) bit is not set immediately, but only after the faults have been cleared.

6.21.2 Operands

Operand	Type	Format	Description
AKD_Torque_Move	AKD_TORQUE_MOVE	Tag	Control tag for this instruction.
Axis	AKD_AXIS	Tag	The name of the axis to enable.
Torque	DINT	Immediate	Desired torque in milliamps.

6.21.3 AKD_TORQUE_MOVE Structure

Mnemonic	Data Type	Description
.EnableIn	BOOL	The enable input bit indicates that the instruction is enabled. It remains set until the instruction completes and the rung-condition-in goes false.
.EnableOut	BOOL	The enable output bit is the output of the enable input bit.
.DN (Done)	BOOL	The done bit indicates when the torque instruction is successful.
.ER (Error)	BOOL	The error bit indicates if the instruction detects an error.

6.21.4 Programming Guidelines

Guideline	Details
In ladder diagram, toggle the rung condition each time you want to execute the instruction.	This is a transitional instruction. In ladder diagram, toggle the rung-condition-in from cleared to set each time you want to execute the instruction.
Use an AKD_Stop_Smooth instruction, or command a zero torque, to stop the move.	See Motion Axis Smooth Stop (AKD_Stop_Smooth) (→ p. 47) for more details.

6.21.5 Execution

Condition	Ladder Diagram Action
Pre-scan	Initialize variables and clear timeout.
Rung-condition-in is false	Reset in progress bit when axis profile is no longer in progress.
Instruction execution	Reset done and error bits, then set torque. Start move and set the done bit to indicate command has been loaded to the drive. If a general fault occurs or there is a communication response timeout, set the error bit.

6.21.6 Changes to Axis Status Bits

Bit Name	State	Meaning
Profile_In_Progress	True	Profile move is in progress.

6.22 Fault Reset (AKD_Fault_Reset)



6.22.1 Description

This instruction will attempt to clear faults. The drive must be disabled before executing this instruction.

NOTE

In most cases, AKD_Shutdown_Reset should be used instead, as it disables the drive and checks that faults have been cleared successfully.

NOTE

The AKD_Fault_Reset instruction execution may take multiple scans to execute because it requires transmission of a message to the motion module and time for the drive to execute the command. The Done (.DN) bit is not set immediately, but only after the faults have been cleared.

6.22.2 Operands

Operand	Type	Format	Description
AKD_Fault_Reset	AKD_FAULT_RESET	Tag	Control tag for this instruction.
Axis	AKD_AXIS	Tag	The name of the axis to reset.

6.22.3 AKD_FAULT_RESET Structure

Mnemonic	Data Type	Description
.EnableIn	BOOL	The enable input bit indicates that the instruction is enabled. It remains set until the instruction completes and the rung-condition-in goes false.
.EnableOut	BOOL	The enable output bit is the output of the enable input bit.
.DN (Done)	BOOL	The done bit indicates when the FaultReset instruction has completed. Check the General_Fault bit to see if faults were all successfully cleared.
.ER (Error)	BOOL	The error bit indicates if the instruction detects an error.

6.22.4 Programming Guidelines

Guideline	Details
In ladder diagram, toggle the rung condition each time you want to execute the instruction.	This is a transitional instruction. In ladder diagram, toggle the rung-condition-in from cleared to set each time you want to execute the instruction.

6.22.5 Execution

Condition	Ladder Diagram Action
Pre-scan	Initialize variables and clear timeout.
Rung-condition-in is false	Reset in progress bit when axis profile is no longer in progress.
Instruction execution	Enable the instruction to initiate the clearing of faults. If a fault condition remains, or the drive is enabled, faults will still be reported when the instruction completes.

6.22.6 Changes to Axis Status Bits

Bit Name	State	Meaning
General_Fault	False	No general fault is present (if successful)
FE_Fault	False	No following error fault is present
Block_Fault	False	No block execution fault is present

7 Troubleshooting

7.1 Introduction

Problems occur for a variety of reasons, depending on the conditions in your program. The causes of errors in multi-axis systems can be especially complex. If you cannot resolve a fault or other issue using the troubleshooting guidance presented below, customer support can give you further assistance.

7.2 .ER (Error) bit

.ER (Error) Bit is set on an AKD add-on instruction if the instruction detects an error. Potential sources of error are:

- Unconfigured axis was specified
- Communication timeout
- Operand value out of range

7.2.1 Unconfigured Axis was Specified

Verify the Axis tag matches the name of the axis you are trying to modify.

7.2.2 Communication Timeout

The instructions share a common “timeout” value in the controller tag `Axis_Internal.CommandTimeout`. This value is used to count down when a command is sent, to ensure a response is received as expected. In some project configurations, this timeout may need to be increased, such as if the rung for an Add-On instruction is only scanned once per second. In this case, increase the value of `CommandTimeout [ms]`. Note that with the default value of 0, the `CommandTimeout` is ignored by all instructions and will never timeout.

AKD_Drive Properties - AKD_Drive (Rung 0)

Vis	Name	Argument	Value	Da
<input type="checkbox"/>	EnableIn		1	BD
<input type="checkbox"/>	EnableOut		1	BD
<input checked="" type="checkbox"/>	Axis_Input	AKD_Axis:I(C)	{...}	AB
<input checked="" type="checkbox"/>	Axis_Output	AKD_Axis:O(C)	{...}	AB
<input checked="" type="checkbox"/>	Axis_Internal	AKD_Axis(C)	{...}	AKI
<input type="checkbox"/>	Axis_Internal.Control	AKD_Axis.Control(C)	{...}	AKI
<input type="checkbox"/>	Axis_Internal.Status	AKD_Axis.Status(C)	{...}	AKI
<input type="checkbox"/>	Axis_Internal.Input	AKD_Axis.Input(C)	{...}	AB
<input type="checkbox"/>	Axis_Internal.Output	AKD_Axis.Output(C)	{...}	AB
<input type="checkbox"/>	Axis_Internal.ResponseMsgType	AKD_Axis.ResponseMsgType(C)	0	SIN
<input checked="" type="checkbox"/>	Axis_Internal.CommandTimeout	AKD_Axis.CommandTimeout(C)	500	NT
<input type="checkbox"/>	Axis_Internal.PositionFeedback	AKD_Axis.PositionFeedback(C)	69942	DIN
<input type="checkbox"/>	Axis_Internal.VelocityFeedback	AKD_Axis.VelocityFeedback(C)	-229	DIN

Parameters: Sort Parameters

Buttons: Insert Instruction Defaults, Insert Definition Defaults, Save Instruction Defaults, OK, Cancel, Apply, Help

Drive Communication

AKD_Drive: AKD_Drive
 Axis_Input: AKD_Axis:1
 Axis_Output: AKD_Axis:0
 Axis_Internal: AKD_Axis

MOV

Source: 0
 Dest: Load_Tasks_Step 0

MOV

Source: 2
 Dest: Main_Sequence_Step 2

JSR

Jump To Subroutine
 Routine Name: Initialization_Sequence

7.2.3 Operand value out of range

Refer to Chapter 5 for valid operand values. For specific AKD parameters, data size and data type are shown in Appendix B. Further information on and descriptions of AKD parameters can be found in [WorkBench Online Help](#).

7.3 AKD Fault

For most AKD Faults, refer to the Fault and Warning Messages table in the AKD Installation Manual for further explanation and possible remedies.

7.3.1 Fieldbus Fault – F702

AKD F702 Fault is set if communication between the drive and controller is lost. The primary cause of this fault is a communication timeout between the drive and controller. The controller is responsible for setting the Requested Packet Interval rate at which cyclic messages are exchanged between the drive and control. If the rate is set too short, communication may timeout. 10ms is the fastest support rate for EtherNet/IP on AKD. For simultaneous operation of WorkBench and EtherNet/IP communications, the rate should be reduced to 20ms.

8 Appendix A: EtherNet/IP Objects and Attributes

The following table provides supported attributes.

8.1 Position Controller Object 0x25

Attribute ID (Decimal Value)	Name	Access Rule	Type	Description
1	Number of Attributes	Get	USINT	Returns the total number of attributes supported by this object in this device.
2	Attribute List	Get	Array of USINT	Returns an array with a list of the attributes supported by this object in this device.
3	Mode	Get/Set	USINT	Operating mode. 0 = Position mode(default), 1 = Velocity mode, 2 = Torque mode.
4	Position Units	Get/Set	DINT	Position Units ratio value is the number of actual position feedback counts equal to one position unit (default 1).
5	Profile Units	Get/Set	DINT	Profile Units ratio value is the number of actual position feedback counts per second or second2 equal to one velocity, acceleration or deceleration unit (default 1).
6	Target Position	Get/Set	DINT	Specifies the target position in counts.
7	Target Velocity	Get/Set	DINT	Specifies the Target Velocity in counts per second.
8	Acceleration	Get/Set	DINT	Not used yet.
9	Deceleration	Get/Set	DINT	Not used yet.
10	Incremental Position Flag	Get/Set	BOOL	Incremental Position Flag 0 := absolute, 1:= incremental.
11	Load Data/Profile Handshake	Get/Set	BOOL	Used to Load Command Data, Start a Profile Move, and indicate that a Profile Move is in progress.
17	Enable	Get/Set	BOOL	Enable Output (same as DRV.EN).
25	Torque	Get/Set	DINT	Output torque.
58	Load Data Complete	Get/Set	BOOL	Indicates that valid data for a valid I/O command message type has been loaded into the position controller device.
100	Home Mode	Get/Set	INT	See home mode section of the WorkBench Online Help .
101	Home Move	Set	BOOL	Initiate a home move.

9 Appendix B: Parameter Listing

The parameters in this list correspond to drive parameters available in WorkBench and are described in the WorkBench help documentation and the WorkBench Online Help.

Position values are scaled according to EIP.PROSUNIT.

Velocity and Acceleration values are scaled according to EIP.PROFUNIT.

Other floating point values are multiplied by 1000, such that a value displayed in WorkBench as 1.001 will be transmitted through EtherNet/IP as 1001.

The lower 32-bits of parameters with the data size 8 can be read by accessing the instance number for the 8 byte parameter incremented by 1.

Instance	Parameter	Data Size	Data Type
1	AIN.CUTOFF	4 Byte	Float
2	AIN.DEADBAND	4 Byte	Float
3	AIN.ISCALE	4 Byte	Float
4	AIN.OFFSET	2 Byte Signed	Float
5	AIN.PSCALE	8 Byte (truncated to 4 Byte)	Position
7	AIN.VALUE	4 Byte	Float
8	AIN.VSCALE	4 Byte	Velocity
9	AIN.ZERO	Command	None
10	AOUT.ISCALE	4 Byte	Float
11	AOUT.MODE	2 Byte	Integer
12	AOUT.OFFSET	4 Byte Signed	Float
13	AOUT.PSCALE	8 Byte (truncated to 4 Byte)	Position
15	AOUT.VALUE	4 Byte Signed	Float
17	AOUT.VALUEU	4 Byte Signed	Float
19	AOUT.VSCALE	4 Byte	Velocity
20	BODE.EXCITEGAP	1 Byte	Integer
21	BODE.FREQ	4 Byte	Float
22	BODE.IAMP	4 Byte Signed	Float
23	BODE.INJECTPOINT	1 Byte	Integer
24	BODE.MODE	1 Byte	Integer
25	BODE.MODETIMER	4 Byte	Integer
26	BODE.PRBDEPTH	1 Byte	Integer
27	BODE.VAMP	8 Byte Signed (truncated to 4 Byte Signed)	Velocity
28	CAP0.EDGE	1 Byte	Integer
29	CAP0.EN	1 Byte	Integer
30	CAP0.EVENT	1 Byte	Integer

Instance	Parameter	Data Size	Data Type
31	CAP0.FILTER	1 Byte	Integer
32	CAP0.MODE	1 Byte	Integer
33	CAP0.PLFB	8 Byte Signed (truncated to 4 Byte Signed)	Position
35	CAP0.PREEDGE	1 Byte	Integer
36	CAP0.PREFILTER	1 Byte	Integer
37	CAP0.PRESLECT	1 Byte	Integer
38	CAP0.STATE	1 Byte	Integer
39	CAP0.T	4 Byte	Integer
40	CAP0.TRIGGER	1 Byte	Integer
41	CAP1.EDGE	1 Byte	Integer
42	CAP1.EN	1 Byte	Integer
43	CAP1.EVENT	1 Byte	Integer
44	CAP1.FILTER	1 Byte	Integer
45	CAP1.MODE	1 Byte	Integer
46	CAP1.PLFB	8 Byte Signed (truncated to 4 Byte Signed)	Position
48	CAP1.PREEDGE	1 Byte	Integer
49	CAP1.PREFILTER	1 Byte	Integer
50	CAP1.PRESELECT	1 Byte	Integer
51	CAP1.STATE	1 Byte	Integer
52	CAP1.T	4 Byte	Integer
53	CAP1.TRIGGER	1 Byte	Integer
54	CS.DEC	8 byte (truncated to 4 Byte)	Acceleration
56	CS.STATE	1 Byte	Integer
57	CS.TO	4 Byte	Integer
58	CS.VTHRESH	8 Byte (truncated to 4 Byte)	Velocity
59	DIN.ROTARY	1 Byte	Integer
60	DIN.STATES	1 Byte	Array
61	DIN1.INV	1 Byte	Integer
62	DIN1.MODE	2 Byte	Integer
63	DIN1.PARAM	8 Byte Signed (truncated to 4 Byte Signed)	Varies
65	DIN1.STATE	1 Byte	Integer
66	DIN2.INV	1 Byte	Integer
67	DIN2.MODE	2 Byte	Integer
68	DIN2.PARAM	8 Byte Signed (truncated to 4 Byte Signed)	Varies

Instance	Parameter	Data Size	Data Type
70	DIN2.STATE	1 Byte	Integer
71	DIN3.INV	1 Byte	Integer
72	DIN3.MODE	2 Byte	Integer
73	DIN3.PARAM	8 Byte Signed (truncated to 4 Byte Signed)	Varies
75	DIN3.STATE	1 Byte	Integer
76	DIN4.INV	1 Byte	Integer
77	DIN4.MODE	2 Byte	Integer
78	DIN4.PARAM	8 Byte Signed (truncated to 4 Byte Signed)	Varies
80	DIN4.STATE	1 Byte	Integer
81	DIN5.INV	1 Byte	Integer
82	DIN5.MODE	2 Byte	Integer
83	DIN5.PARAM	8 Byte Signed (truncated to 4 Byte Signed)	Varies
85	DIN5.STATE	1 Byte	Integer
86	DIN6.INV	1 Byte	Integer
87	DIN6.MODE	2 Byte	Integer
88	DIN6.PARAM	8 Byte Signed (truncated to 4 Byte Signed)	Varies
90	DIN6.STATE	1 Byte	Integer
91	DIN7.INV	1 Byte	Integer
92	DIN7.MODE	2 Byte	Integer
93	DIN7.PARAM	8 Byte Signed (truncated to 4 Byte Signed)	Varies
95	DIN7.STATE	1 Byte	Integer
96	DOUT.CTRL	1 Byte	Integer
97	DOUT.RELAYMODE	1 Byte	Integer
98	DOUT.STATES	1 Byte	Array
99	DOUT1.MODE	1 Byte	Integer
100	DOUT1.PARAM	4 Byte Signed	Float
102	DOUT1.STATE	1 Byte	Integer
103	DOUT1.STATEU	1 Byte	Integer
104	DOUT2.MODE	1 Byte	Integer
105	DOUT2.PARAM	4 Byte Signed	Float
107	DOUT2.STATE	1 Byte	Integer
108	DOUT2.STATEU	1 Byte	Integer
109	DRV.ACC	8 Byte (truncated to 4 Byte)	Acceleration
111	DRV.ACTIVE	1 Byte	Integer

Instance	Parameter	Data Size	Data Type
112	DRV.CLRFAULTHIST	Command	None
113	DRV.CLRFAULTS	Command	None
114	DRV.CMDSOURCE	1 Byte	Integer
115	DRV.DBILIMIT	4 Byte	Float
116	DRV.DEC	8 Byte (truncated to 4 Byte)	Acceleration
118	DRV.DIR	1 Byte	Integer
119	DRV.DI	Command	None
120	DRV.DISMODE	1 Byte	Integer
121	DRV.DISSOURCES	2 Byte	Integer
122	DRV.DISTO	4 Byte	Integer
123	DRV.EMUEDIR	1 Byte	Integer
124	DRV.EMUEMODE	2 Byte	Integer
125	DRV.EMUEMTURN	4 Byte	Integer
126	DRV.EMUERES	4 Byte	Integer
127	DRV.EMUEZOFFSET	2 Byte	Integer
128	DRV.EN	Command	None
129	DRV.ENDEFAULT	1 Byte	Integer
130	DRV.HANDWHEEL	4 Byte	Integer
131	DRV.HWENMODE	1 Byte	Integer
132	DRV.ICONT	4 Byte Signed	Float
133	DRV.IPEAK	4 Byte Signed	Float
134	DRV.IZERO	4 Byte	Float
135	DRV.MOTIONSTAT	4 Byte	Integer
136	DRV.OPMODE	1 Byte	Integer
137	DRV.RSTVAR	Command	None
138	DRV.STOP	Command	None
139	DRV.TYPE	1 Byte	Integer
140	DRV.ZERO	1 Byte	Integer
141	FB1.BISSBITS	1 Byte	Integer
142	FB1.ENCREC	4 Byte	Integer
143	FB1.IDENTIFIED	1 Byte	Integer
144	FB1.INITSIGNED	1 Byte Signed	Integer
145	FB1.MECHPOS	4 Byte	Integer
146	FB1.OFFSET	8 Byte Signed (truncated to 4 Byte Signed)	Position

Instance	Parameter	Data Size	Data Type
148	FB1.ORIGIN	8 Byte (truncated to 4 Byte)	Position
150	FB1.PFIND	1 Byte	Integer
151	FB1.PFINDCMDU	4 Byte	Float
152	FB1.POLES	2 Byte	Integer
153	FB1.PSCALE	1 Byte	Integer
154	FB1.RESKTR	4 Byte	Float
155	FB1.RESREFPHASE	4 Byte Signed	Float
156	FB1.SELECT	1 Byte Signed	Integer
157	FB1.TRACKINGCAL	1 Byte	Integer
158	FBUS.PARAM01	4 Byte	Integer
159	FBUS.PARAM02	4 Byte	Integer
160	FBUS.PARAM03	4 Byte	Integer
161	FBUS.PARAM04	4 Byte	Integer
162	FBUS.PARAM05	4 Byte	Integer
163	FBUS.PARAM06	4 Byte	Integer
164	FBUS.PARAM07	4 Byte	Integer
178	FBUS.PLLTHRESH	2 Byte	Integer
179	FBUS.SAMPLEPERIOD	1 Byte	Integer
180	FBUS.SYNCACT	4 Byte	Integer
181	FBUS.SYNCDIST	4 Byte	Integer
182	FBUS.SYNCWND	4 Byte	Integer
183	FBUS.TYPE	1 Byte	Integer
184	GEAR.ACCMAX	8 Byte (truncated to 4 Byte)	Acceleration
186	GEAR.DECMAX	8 Byte (truncated to 4 Byte)	Acceleration
188	GEAR.IN	2 Byte	Integer
189	GEAR.MODE	2 Byte	Integer
190	GEAR.MOVE	Command	None
191	GEAR.OUT	2 Byte signed	Integer
192	GEAR.VMAX	8 Byte (truncated to 4 Byte)	Velocity
193	HOME.ACC	8 Byte (truncated to 4 Byte)	Acceleration
195	HOME.AUTOMOVE	1 Byte	Integer
196	HOME.DEC	8 Byte (truncated to 4 Byte)	Acceleration
198	HOME.DIR	2 Byte	Integer
199	HOME.DIST	8 Byte Signed (truncated to 4 Byte Signed)	Position

Instance	Parameter	Data Size	Data Type
201	HOME.FEEDRATE	2 Byte	Integer
202	HOME.IPEAK	4 Byte Signed	Float
204	HOME.MODE	2 Byte	Integer
205	HOME.MOVE	Command	None
206	HOME.P	8 Byte Signed (truncated to 4 Byte Signed)	Position
208	HOME.PERRTHRESH	8 Byte Signed (truncated to 4 Byte Signed)	Position
210	HOME.SET	Command	None
211	HOME.V	8 Byte (truncated to 4 Byte)	Velocity
212	HWLS.NEGSTATE	1 Byte	Integer
213	HWLS.POSSTATE	1 Byte	Integer
214	IL.BUSFF	4 Byte Signed	Float
215	IL.CMD	4 Byte Signed	Float
217	IL.FB	4 Byte Signed	Float
218	IL.FF	4 Byte	Float
219	IL.FOLDFTHRESH	4 Byte	Float
220	IL.FOLDFTHRESHU	4 Byte Signed	Float
221	IL.FOLDWTHRESH	4 Byte Signed	Float
222	IL.FRICTION	4 Byte	Float
223	IL.IFOLDS	4 Byte	Float
224	IL.IUFB	4 Byte Signed	Float
225	IL.IVFB	4 Byte Signed	Float
226	IL.KACCFF	4 Byte Signed	Float
227	IL.KBUSFF	4 Byte	Float
228	IL.KP	4 Byte	Float
229	IL.KPDRATIO	4 Byte	Float
230	IL.KVFF	4 Byte Signed	Float
231	IL.LIMITN	4 Byte Signed	Float
232	IL.LIMITP	4 Byte Signed	Float
233	IL.MFOLDD	4 Byte	Float
234	IL.MFOLDR	4 Byte	Float
235	IL.MFOLDT	4 Byte	Float
236	IL.MIFOLD	4 Byte	Float
237	IL.OFFSET	4 Byte Signed	Float
238	IL.VCMD	2 Byte Signed	Integer

Instance	Parameter	Data Size	Data Type
239	IL.VUFB	2 Byte Signed	Integer
240	IL.VVFB	2 Byte Signed	Integer
241	MOTOR.AUTOSET	1 Byte	Integer
242	MOTOR.BRAKE	1 Byte	Integer
243	MOTOR.BRAKERLS	1 Byte	Integer
244	MOTOR.CTF0	4 Byte	Float
245	MOTOR.ICONT	4 Byte	Float
246	MOTOR.IDDATAVALID	1 Byte	Integer
247	MOTOR.INTERTIA	4 Byte	Float
248	MOTOR.IPEAK	4 Byte	Float
249	MOTOR.KT	4 Byte	Float
250	MOTOR.LQLL	4 Byte	Float
251	MOTOR.PHASE	2 Byte	Integer
252	MOTOR.PITCH	4 Byte	Float
253	MOTOR.POLES	2 Byte	Integer
254	MOTOR.R	4 Byte	Float
255	MOTOR.RTYPE	1 Byte	Integer
256	MOTOR.TBRAKEAPP	2 Byte	Integer
257	MOTOR.TBRAKERLS	2 Byte	Integer
258	MOTOR.TEMP	4 Byte	Integer
259	MOTOR.TEMPFAULT	4 Byte	Integer
260	MOTOR.TEMPWARN	4 Byte	Integer
261	MOTOR.TYPE	1 Byte	Integer
262	MOTOR.VMAX	2 Byte	Integer
263	MOTOR.VOLTMAX	2 Byte	Integer
264	MT,ACC	8 Byte (truncated to 4 Byte)	Acceleration
266	MT.CLEAR	2 Byte Signed	Integer
267	MT.CNTL	4 Byte	Integer
268	MT.CONTINUE	Command	None
269	MT.DEC	8 Byte (truncated to 4 Byte)	Acceleration
271	MT.EMERGMT	2 Byte Signed	Integer
272	MT.LOAD	Command	None
273	MT.MOVE	2 Byte Command	None
274	MT.MTNEXT	1 Byte	Integer

Instance	Parameter	Data Size	Data Type
275	MT.NUM	1 Byte	Integer
276	MT.P	8 Byte Signed (truncated to 4 Byte Signed)	Position
278	MT.SET	1 Byte Command	None
279	MT.TNEXT	2 Byte	Integer
280	MT.TNUM	1 Byte	Integer
281	MT.TPOSWND	8 Byte Signed (truncated to 4 Byte Signed)	Position
283	MT.TVELWND	8 Byte (truncated to 4 Byte)	Velocity
284	MT.V	8 Byte (truncated to 4 Byte)	Velocity
285	MT.VCMD	8 Byte Signed (truncated to 4 Byte Signed)	Velocity
286	PL.CMD	8 Byte (truncated to 4 Byte)	Position
288	PL.ERR	8 Byte (truncated to 4 Byte)	Position
290	PL.ERRMODE	1 Byte	Integer
291	PL.ERRFTHRESH	8 Byte (truncated to 4 Byte)	Position
293	PL.ERRWTHRESH	8 Byte (truncated to 4 Byte)	Position
295	PL.FB	8 Byte Signed (truncated to 4 Byte Signed)	Position
297	PL.FBSOURCE	1 Byte	Integer
298	PL.INTINMAX	8 Byte (truncated to 4 Byte)	Position
300	PL.INTOUTMAX	8 Byte (truncated to 4 Byte)	Position
302	PL.KI	4 Byte	Float
303	PL.KP	4 Byte	Float
304	PL.MODP1	8 Byte Signed (truncated to 4 Byte Signed)	Position
306	PL.MODP2	8 Byte Signed (truncated to 4 Byte Signed)	Position
308	PL.MODPDIR	1 Byte	Integer
309	PL.MODPEN	1 Byte	Integer
310	PLS.EN	2 Byte	Integer
311	PLS.MODE	2 Byte	Integer
312	PLS.P1	8 Byte Signed (truncated to 4 Byte Signed)	Position
314	PLS.P2	8 Byte Signed (truncated to 4 Byte Signed)	Position
316	PLS.P3	8 Byte Signed (truncated to 4 Byte Signed)	Position
318	PLS.P4	8 Byte Signed (truncated to 4 Byte Signed)	Position
320	PLS.P5	8 Byte Signed (truncated to 4 Byte Signed)	Position
322	PLS.P6	8 Byte Signed (truncated to 4 Byte Signed)	Position
324	PLS.P7	8 Byte Signed (truncated to 4 Byte Signed)	Position
326	PLS.P8	8 Byte Signed (truncated to 4 Byte Signed)	Position

Instance	Parameter	Data Size	Data Type
328	PLS.RESET	2 Byte	Integer
329	PLS.STATE	2 Byte	Integer
330	PLS.T1	2 Byte	Integer
331	PLS.T2	2 Byte	Integer
332	PLS.T3	2 Byte	Integer
333	PLS.T4	2 Byte	Integer
334	PLS.T5	2 Byte	Integer
335	PLS.T6	2 Byte	Integer
336	PLS.T7	2 Byte	Integer
337	PLS.T8	2 Byte	Integer
338	PLS.UNITS	1 Byte	Integer
339	PLS.WIDTH1	8 Byte Signed (truncated to 4 Byte Signed)	Position
341	PLS.WIDTH2	8 Byte Signed (truncated to 4 Byte Signed)	Position
343	PLS.WIDTH3	8 Byte Signed (truncated to 4 Byte Signed)	Position
345	PLS.WIDTH4	8 Byte Signed (truncated to 4 Byte Signed)	Position
347	PLS.WIDTH5	8 Byte Signed (truncated to 4 Byte Signed)	Position
349	PLS.WIDTH6	8 Byte Signed (truncated to 4 Byte Signed)	Position
351	PLS.WIDTH7	8 Byte Signed (truncated to 4 Byte Signed)	Position
353	PLS.WIDTH8	8 Byte Signed (truncated to 4 Byte Signed)	Position
355	REC.ACTIVE	1 Byte	Integer
356	REC.DONE	1 Byte	Integer
357	REC.GAP	2 Byte	Integer
358	REC.NUMPOINTS	2 Byte	Integer
359	REC.OFF	Command	None
360	REC.STOPTYPE	1 Byte	Integer
361	REC.TRIG	Command	None
362	REC.TRIGPOS	1 Byte	Integer
363	REC.TRIGPRMLIST	-	String
364	REC.TRIGSLOPE	1 Byte	Integer
365	REC.TRIGTYPE	1 Byte	Integer
366	REC.TRIGVAL	8 Byte Signed (truncated to 4 Byte Signed)	Varies
368	REGEN.POWER	8 Byte (truncated to 4 Byte)	Integer
370	REGEN.REXT	2 Byte	Integer
371	REGEN.TEXT	4 Byte	Float

Instance	Parameter	Data Size	Data Type
372	REGEN.TYPE	1 Byte Signed	Integer
373	REGEN.WATTEXT	2 Byte	Integer
374	SM.I1	4 Byte Signed	Float
375	SM.I2	4 Byte Signed	Float
376	SM.MODE	2 Byte	Integer
377	SM.MOVE	Command	None
378	SM.T1	2 Byte	Integer
379	SM.T2	2 Byte	Integer
380	SM.V1	8 Byte Signed (truncated to 4 Byte Signed)	Velocity
381	SM.V2	8 Byte Signed (truncated to 4 Byte Signed)	Velocity
382	STO.STATE	1 Byte	Integer
383	SWLS.EN	2 Byte	Integer
384	SWLS.LIMIT0	8 Byte Signed (truncated to 4 Byte Signed)	Position
386	SWLS.LIMIT1	8 Byte Signed (truncated to 4 Byte Signed)	Position
388	SWLS.STATE	2 Byte	Integer
389	UNIT.ACCLINEAR	1 Byte	Integer
390	UNIT.ACCROTARY	1 Byte	Integer
391	UNIT.PIN	4 Byte	Integer
392	UNIT.PLINEAR	1 Byte	Integer
393	UNIT.POUT	4 Byte	Integer
394	UNIT.PROTARY	1 Byte	Integer
395	UNIT.VLINEAR	1 Byte	Integer
396	UNIT.VROTARY	1 Byte	Integer
397	VBUS.CALGAIN	4 Byte	Float
398	VBUS.OVFTHRESH	2 Byte	Integer
399	VBUS.OVWTHRESH	2 Byte	Integer
400	VBUS.RMSLIMIT	1 Byte	Integer
401	VBUS.UVFTHRESH	2 Byte	Integer
402	VBUS.UVMODE	1 Byte	Integer
403	VBUS.UVWTHRESH	2 Byte	Integer
404	VBUS.VALUE	4 Byte	Float
405	VL.ARP1	4 Byte	Float
406	VL.ARP2	4 Byte	Float
407	VL.ARP3	4 Byte	Float

Instance	Parameter	Data Size	Data Type
408	VL.ARP4	4 Byte	Float
409	VL.ARPQ1	4 Byte	Float
410	VL.ARPQ2	4 Byte	Float
411	VL.ARPQ3	4 Byte	Float
412	VL.ARPQ4	4 Byte	Float
413	VL.ARTYPE1	1 Byte	Integer
414	VL.ARTYPE2	1 Byte	Integer
415	VL.ARTYPE3	1 Byte	Integer
416	VL.ARTYPE4	1 Byte	Integer
417	VL.ARZF1	4 Byte	Float
418	VL.ARZF2	4 Byte	Float
419	VL.ARZF3	4 Byte	Float
420	VL.ARZF4	4 Byte	Float
421	VL.ARZQ1	4 Byte	Float
422	VL.ARZQ2	4 Byte	Float
423	VL.ARZQ3	4 Byte	Float
424	VL.ARZQ4	4 Byte	Float
425	VL.BUSFF	8 Byte Signed (truncated to 4 Byte Signed)	Velocity
426	VL.CMD	8 Byte Signed (truncated to 4 Byte Signed)	Velocity
427	VL.CMDU	8 Byte Signed (truncated to 4 Byte Signed)	Velocity
428	VL.ERR	8 Byte Signed (truncated to 4 Byte Signed)	Velocity
429	VL.FB	8 Byte Signed (truncated to 4 Byte Signed)	Velocity
430	VL.FBFILTER	8 Byte Signed (truncated to 4 Byte Signed)	Velocity
431	VL.FBSOURCE	1 Byte	Integer
432	VL.FF	8 Byte Signed (truncated to 4 Byte Signed)	Velocity
433	VL.GENMODE	2 Byte	Velocity
434	VL.KBUSFF	4 Byte	Float
435	VL.KI	4 Byte	Float
436	VL.KO	4 Byte	Float
437	VL.KP	4 Byte	Float
438	VL.KVFF	4 Byte	Float
439	VL.LIMITN	8 Byte Signed (truncated to 4 Byte Signed)	Velocity
440	VL.LIMITP	8 Byte (truncated to 4 Byte)	Velocity
441	VL.LMJR	4 Byte	Float

Instance	Parameter	Data Size	Data Type
442	VL.MODEL	8 Byte Signed (truncated to 4 Byte Signed)	Velocity
443	VL.OBSBW	4 Byte	Float
444	VL.OBSMODE	4 Byte	Integer
445	VL.THRESH	8 Byte Signed (truncated to 4 Byte Signed)	Velocity
446	WS.ARM	Command	None
447	WS.DISTMAX	8 Byte Signed (truncated to 4 Byte Signed)	Position
449	WS.DISTMIN	8 Byte Signed (truncated to 4 Byte Signed)	Position
451	WS.IMAX	4 Byte Signed	Float
452	WS.MODE	1 Byte	Integer
453	WS.NUMLOOPS	1 Byte	Integer
454	WS.STATE	1 Byte	Integer
455	WS.T	2 Byte	Integer
456	WS.TDELAY1	2 Byte	Integer
457	WS.TDELAY2	2 Byte	Integer
458	WS.TDELAY3	2 Byte	Integer
459	WS.VTHRESH	8 Byte Signed (truncated to 4 Byte Signed)	Velocity
460	DIN1.FILTER	2 Byte	Integer
461	DIN2.FILTER	2 Byte	Integer
462	DIN3.FILTER	2 Byte	Integer
463	DIN4.FILTER	2 Byte	Integer
464	DIN5.FILTER	2 Byte	Integer
465	DIN6.FILTER	2 Byte	Integer
466	DIN7.FILTER	2 Byte	Integer
467	FB1.HALLSTATEU	1 Byte	Integer
468	FB1.HALLSTATEV	1 Byte	Integer
469	FB1.HALLSTATEW	1 Byte	Integer
470	DRV.NVSAVE	Command	None
471	MODBUS.DIO	4 Byte	Integer
472	MODBUS.DRV	4 Byte	Integer
473	MODBUS.DRVSTAT	4 Byte	Integer
474	MODBUS.HOME	4 Byte	Integer
475	MODBUS.MOTOR	4 Byte	Integer
476	MODBUS.MT	2 Byte	Integer
477	MODBUS.SM	4 Byte	Integer

Instance	Parameter	Data Size	Data Type
478	DRV.FAULT1	2 Byte	Integer
479	DRV.FAULT2	2 Byte	Integer
480	DRV.FAULT3	2 Byte	Integer
481	DRV.FAULT4	2 Byte	Integer
482	DRV.FAULT5	2 Byte	Integer
483	DRV.FAULT6	2 Byte	Integer
484	DRV.FAULT7	2 Byte	Integer
485	DRV.FAULT8	2 Byte	Integer
486	DRV.FAULT9	2 Byte	Integer
487	DRV.FAULT10	2 Byte	Integer
488	MODBUS.PIN	4 Byte	Integer
489	MODBUS.POUT	4 Byte	Integer
490	MODBUS.PSCALE	2 Byte	Integer
491	MODBUS.UNITLABEL	-	String
492	MOTOR.HFPHASEREAD	2 Byte	Integer
493	FB2.ENCRESES	4 Byte	Integer
494	FB2.MODE	2 Byte	Integer
495	FB2.SOURCE	2 Byte	Integer
496	MOTOR.TBRAKETO	2 Byte	Integer
497	MODBUS.MSGLOG	1 Byte	Integer
498	USER.INT1	4 Byte Signed	Integer
499	USER.INT2	4 Byte Signed	Integer
500	USER.INT3	4 Byte Signed	Integer
501	USER.INT4	4 Byte Signed	Integer
502	USER.INT5	4 Byte Signed	Integer
503	USER.INT6	4 Byte Signed	Integer
504	USER.INT7	4 Byte Signed	Integer
505	USER.INT8	4 Byte Signed	Integer
506	USER.INT9	4 Byte Signed	Integer
507	USER.INT10	4 Byte Signed	Integer
508	USER.INT11	4 Byte Signed	Integer
509	USER.INT12	4 Byte Signed	Integer
510	USER.INT13	4 Byte Signed	Integer
511	USER.INT14	4 Byte Signed	Integer

Instance	Parameter	Data Size	Data Type
512	USER.INT15	4 Byte Signed	Integer
513	USER.INT16	4 Byte Signed	Integer
514	USER.INT17	4 Byte Signed	Integer
515	USER.INT18	4 Byte Signed	Integer
516	USER.INT19	4 Byte Signed	Integer
517	USER.INT20	4 Byte Signed	Integer
518	USER.INT21	4 Byte Signed	Integer
519	USER.INT22	4 Byte Signed	Integer
520	USER.INT23	4 Byte Signed	Integer
521	USER.INT24	4 Byte Signed	Integer
522	DRV.NVCHECK	8 Byte (truncated to 4 Byte)	Integer
523	FB3.MODE	2 Byte	Integer
524	FB3.P	8 Byte (truncated to 4 Byte)	Integer
525	MODBUS.SCALING	1 Byte	Integer
526	DRV.EMUEPULSEWIDTH	4 Byte	Float
527	DRV.EMUECHECKSPEED	1 Byte	Integer
528	DRV.HWENABLE	1 Byte	Integer
529	DRV.SWENABLE	1 Byte	Integer
530	DRV.TIME	4 Byte	Integer
531	EGEAR.ACCLIMIT	4 Byte	Float
532	EGEAR.DECLIMIT	4 Byte	Float
533	EGEAR.ERROR	8 Byte Signed (truncated to 4 Byte Signed)	Integer
534	EGEAR.LOCK	1 Byte	Integer
535	EGEAR.ON	1 Byte	Integer
536	EGEAR.PULSESIN	2 Byte	Integer
537	EGEAR.PULSESOUT	2 Byte Signed	Integer
538	EGEAR.RATIO	4 Byte Signed	Float
539	EGEAR.TYPE	1 Byte	Integer
540	EXTENCODER.FREQ	4 Byte	Float
541	EXTENCODER.POSITION	8 Byte Signed (truncated to 4 Byte Signed)	Integer
543	EXTENCODER.POSMODULO	8 Byte (truncated to 4 Byte)	Integer
545	MOVE.ACC	8 Byte (truncated to 4 Byte)	None
547	MOVE.DEC	8 Byte (truncated to 4 Byte)	None
549	MOVE.DIR	4 Byte	Integer

Instance	Parameter	Data Size	Data Type
550	MOVE.GOABS	Command	None
551	MOVE.GOABSREG	Command	None
552	MOVE.GOHOME	Command	None
553	MOVE.GORELREG	Command	None
554	MOVE.GOREL	Command	None
555	MOVE.GOUPDATE	Command	None
556	MOVE.GOVEL	Command	None
557	MOVE.INPOSITION	4 Byte	Integer
558	MOVE.INPOSLIMIT	8 Byte Signed (truncated to 4 Byte Signed)	Position
560	MOVE.MOVING	4 Byte	Integer
561	MOVE.POSCOMMAND	8 Byte Signed (truncated to 4 Byte Signed)	Position
566	MOVE.REGOFFSET	8 Byte Signed (truncated to 4 Byte Signed)	Position
568	MOVE.RELATIVEDIST	8 Byte Signed (truncated to 4 Byte Signed)	Position
570	MOVE.RUNSPEED	8 Byte (truncated to 4 Byte)	None
572	MOVE.SCURVETIME	4 Byte	Float
573	MOVE.ABORT	Command	None
574	MOVE.TARGETPOS	8 Byte Signed (truncated to 4 Byte Signed)	Position
576	MOVE.VCMD	4 Byte Signed	None
577	VM.AUTOSTART	4 Byte	Integer
578	VM.RESTART	Command	None
579	VM.START	Command	None
580	VM.STATE	1 Byte	Integer
581	VM.STOP	Command	None
582	VM.ERR	4 Byte	Integer
583	WHEN.FB1MECHPOS	4 Byte	Integer
584	WHEN.FB3P	8 Byte Signed (truncated to 4 Byte Signed)	Integer
586	WHEN.DRVHANDWHEEL	4 Byte	Integer
587	WHEN.DRVTIME	4 Byte	Integer
588	WHEN.PLCMD	8 Byte Signed (truncated to 4 Byte Signed)	Integer
590	WHEN.PLFB	8 Byte Signed (truncated to 4 Byte Signed)	Integer
592	MOVE.DWELLTIME	4 Byte	Integer
593	IL.MI2T	4 Byte	Float
594	AIN.DEADBANDMODE	2 Byte	Integer
595	AIN.MODE	1 Byte	Integer

Instance	Parameter	Data Size	Data Type
596	DIO10.DIR	1 Byte	Integer
597	DIO10.INV	1 Byte	Integer
598	DIO11.DIR	1 Byte	Integer
599	DIO11.INV	1 Byte	Integer
600	DIO9.DIR	1 Byte	Integer
601	DIO9.INV	1 Byte	Integer
602	FAULT130.ACTION	1 Byte	Integer
603	FAULT131.ACTION	1 Byte	Integer
604	FAULT132.ACTION	1 Byte	Integer
605	FAULT134.ACTION	1 Byte	Integer
606	FAULT702.ACTION	1 Byte	Integer
607	IP.MODE	2 Byte	Integer
608	LOAD.INERTIA	4 Byte	Float
609	MOTOR.KE	4 Byte	Float
610	VBUS.HALFVOLT	1 Byte	Integer
611	FB2.DIR	1 Byte	Integer
612	FAULT451.ACTION	1 Byte	Integer
613	DRV.HWENDELAY	1 Byte	Integer
614	DRV.HANDWHEELSRC	1 Byte	Integer
615	IL.KPLOOKUPINDEX	2 Byte	Integer
616	IL.KPLOOKUPVALUE	4 Byte	Float
617	MOTOR.BRAKEIMM	1 Byte	Integer
618	AIN2.CUTOFF	4 Byte	Float
619	AIN2.DEADBAND	2 Byte	Float
620	AIN2.DEADBANDMODE	2 Byte	Integer
621	AIN2.ISCALE	4 Byte	Float
622	AIN2.MODE	1 Byte	Integer
623	AIN2.OFFSET	4 Byte Signed	Float
624	AIN2.PSCALE	8 Byte (truncated to 4 Byte)	Position
626	AIN2.VALUE	4 Byte	Float
627	AIN2.VSCALE	8 Byte (truncated to 4 Byte)	Velocity
630	AIN2.ZERO	Command	None
636	AOUT.CUTOFF	4 Byte	Float
637	AOUT2.CUTOFF	4 Byte	Float

Instance	Parameter	Data Size	Data Type
638	AOUT2.ISCALE	4 Byte	Float
639	AOUT2.MODE	2 Byte	Integer
640	AOUT2.OFFSET	4 Byte Signed	Float
641	AOUT2.PSCALE	8 Byte (truncated to 4 Byte)	Position
643	AOUT2.VALUE	4 Byte Signed	Float
645	AOUT2.VALUEU	4 Byte Signed	Float
647	AOUT2.VSCALE	8 Byte (truncated to 4 Byte)	Velocity
649	BODE.IFLIMIT	4 Byte Signed	Float
650	BODE.IFTHRESH	4 Byte Signed	Float
651	BODE.VFLIMIT	4 Byte Signed	Float
652	BODE.VFTHRESH	8 Byte Signed (truncated to 4 Byte Signed)	Velocity
654	DIN10.STATE	1 Byte	Integer
655	DIN11.STATE	1 Byte	Integer
656	DIN21.FILTER	2 Byte	Integer
657	DIN21.INV	1 Byte	Integer
658	DIN21.MODE	2 Byte	Integer
659	DIN21.PARAM	8 Byte Signed (truncated to 4 Byte Signed)	Varies
661	DIN21.STATE	1 Byte	Integer
662	DIN22.FILTER	2 Byte	Integer
663	DIN22.INV	1 Byte	Integer
664	DIN22.MODE	2 Byte	Integer
665	DIN22.PARAM	8 Byte Signed (truncated to 4 Byte Signed)	Varies
667	DIN22.STATE	1 Byte	Integer
668	DIN23.FILTER	2 Byte	Integer
669	DIN23.INV	1 Byte	Integer
670	DIN23.MODE	2 Byte	Integer
671	DIN23.PARAM	8 Byte Signed (truncated to 4 Byte Signed)	Varies
673	DIN23.STATE	1 Byte	Integer
674	DIN24.FILTER	2 Byte	Integer
675	DIN24.INV	1 Byte	Integer
676	DIN24.MODE	2 Byte	Integer
677	DIN24.PARAM	8 Byte Signed (truncated to 4 Byte Signed)	Varies
679	DIN24.STATE	1 Byte	Integer
680	DIN25.FILTER	2 Byte	Integer

Instance	Parameter	Data Size	Data Type
681	DIN25.INV	1 Byte	Integer
682	DIN25.MODE	2 Byte	Integer
683	DIN25.PARAM	8 Byte Signed (truncated to 4 Byte Signed)	Varies
685	DIN25.STATE	1 Byte	Integer
686	DIN26.FILTER	2 Byte	Integer
687	DIN26.INV	1 Byte	Integer
688	DIN26.MODE	2 Byte	Integer
689	DIN26.PARAM	8 Byte Signed (truncated to 4 Byte Signed)	Varies
691	DIN26.STATE	1 Byte	Integer
692	DIN27.FILTER	2 Byte	Integer
693	DIN27.INV	1 Byte	Integer
694	DIN27.MODE	2 Byte	Integer
695	DIN27.PARAM	8 Byte Signed (truncated to 4 Byte Signed)	Varies
697	DIN27.STATE	1 Byte	Integer
698	DIN28.FILTER	2 Byte	Integer
699	DIN28.INV	1 Byte	Integer
700	DIN28.MODE	2 Byte	Integer
701	DIN28.PARAM	8 Byte Signed (truncated to 4 Byte Signed)	Varies
703	DIN28.STATE	1 Byte	Integer
704	DIN29.FILTER	2 Byte	Integer
705	DIN29.INV	1 Byte	Integer
706	DIN29.MODE	2 Byte	Integer
707	DIN29.PARAM	8 Byte Signed (truncated to 4 Byte Signed)	Varies
709	DIN29.STATE	1 Byte	Integer
710	DIN30.FILTER	2 Byte	Integer
711	DIN30.INV	1 Byte	Integer
712	DIN30.MODE	2 Byte	Integer
713	DIN30.PARAM	8 Byte Signed (truncated to 4 Byte Signed)	Varies
715	DIN30.STATE	1 Byte	Integer
716	DIN31.FILTER	2 Byte	Integer
717	DIN31.INV	1 Byte	Integer
718	DIN31.MODE	2 Byte	Integer
719	DIN31.PARAM	8 Byte Signed (truncated to 4 Byte Signed)	Varies
721	DIN31.STATE	1 Byte	Integer

Instance	Parameter	Data Size	Data Type
722	DIN32.FILTER	2 Byte	Integer
723	DIN32.INV	1 Byte	Integer
724	DIN32.MODE	2 Byte	Integer
725	DIN32.PARAM	8 Byte Signed (truncated to 4 Byte Signed)	Varies
727	DIN32.STATE	1 Byte	Integer
728	DIN9.STATE	1 Byte	Integer
729	DOU10.STATE	1 Byte	Integer
730	DOU10.STATEU	1 Byte	Integer
731	DOU11.STATE	1 Byte	Integer
732	DOU11.STATEU	1 Byte	Integer
733	DOU21.MODE	1 Byte	Integer
734	DOU21.PARAM	4 Byte Signed	Float
736	DOU21.STATE	1 Byte	Integer
737	DOU21.STATEU	1 Byte	Integer
738	DOU22.MODE	1 Byte	Integer
739	DOU22.PARAM	4 Byte Signed	Float
741	DOU22.STATE	1 Byte	Integer
742	DOU22.STATEU	1 Byte	Integer
743	DOU23.MODE	1 Byte	Integer
744	DOU23.PARAM	4 Byte Signed	Float
746	DOU23.STATE	1 Byte	Integer
747	DOU23.STATEU	1 Byte	Integer
748	DOU24.MODE	1 Byte	Integer
749	DOU24.PARAM	4 Byte Signed	Float
751	DOU24.STATE	1 Byte	Integer
752	DOU24.STATEU	1 Byte	Integer
753	DOU25.MODE	1 Byte	Integer
754	DOU25.PARAM	4 Byte Signed	Float
756	DOU25.STATE	1 Byte	Integer
757	DOU25.STATEU	1 Byte	Integer
758	DOU26.MODE	1 Byte	Integer
759	DOU26.PARAM	4 Byte Signed	Float
761	DOU26.STATE	1 Byte	Integer
762	DOU26.STATEU	1 Byte	Integer

Instance	Parameter	Data Size	Data Type
763	DOUT27.MODE	1 Byte	Integer
764	DOUT27.PARAM	4 Byte Signed	Float
766	DOUT27.STATE	1 Byte	Integer
767	DOUT27.STATEU	1 Byte	Integer
768	DOUT28.MODE	1 Byte	Integer
769	DOUT28.PARAM	4 Byte Signed	Float
771	DOUT28.STATE	1 Byte	Integer
772	DOUT28.STATEU	1 Byte	Integer
773	DOUT29.MODE	1 Byte	Integer
774	DOUT29.PARAM	4 Byte Signed	Float
776	DOUT29.STATE	1 Byte	Integer
777	DOUT29.STATEU	1 Byte	Integer
778	DOUT30.MODE	1 Byte	Integer
779	DOUT30.PARAM	4 Byte Signed	Float
781	DOUT30.STATE	1 Byte	Integer
782	DOUT30.STATEU	1 Byte	Integer
783	DOUT9.STATE	1 Byte	Integer
784	DOUT9.STATEU	1 Byte	Integer
785	DRV.BLINKDISPLAY	Command	None
786	DRV.CLRCRASHDUMP	Command	None
787	DRV.CMDDELAY	4 Byte	Float
789	DRV.NVLOAD	Command	None
790	DRV.RUNTIME		String
791	DRV.SETUPREQBITS	4 Byte	Integer
792	DRV.WARNING1	4 Byte	Integer
793	DRV.WARNING2	4 Byte	Integer
794	DRV.WARNING3	4 Byte	Integer
795	EIP.CONNECTED	1 Byte	Integer
796	EIP.POSUNIT	4 Byte	Integer
797	EIP.PROFUNIT	4 Byte	Integer
798	FAULT139.ACTION	1 Byte	Integer
803	FB1.CALTHRESH	8 Byte (truncated to 4 Byte)	Integer
806	FB1.P	8 Byte Signed (truncated to 4 Byte Signed)	Position
808	FB1.PDIR	1 Byte	Integer

Instance	Parameter	Data Size	Data Type
809	FB1.PIN	4 Byte	Integer
810	FB1.POFFSET	8 Byte Signed (truncated to 4 Byte Signed)	Position
812	FB1.POUT	4 Byte	Integer
813	FB1.PUNIT	4 Byte	Integer
814	FB1.USERBYTE	1 Byte	Integer
815	FB1.USERDWORD	4 Byte	Integer
816	FB1.USERWORD	2 Byte	Integer
817	FB2.P	8 Byte Signed (truncated to 4 Byte Signed)	Integer
819	FB2.PIN	4 Byte	Integer
820	FB2.POFFSET	8 Byte Signed (truncated to 4 Byte Signed)	Position
822	FB2.POUT	4 Byte	Integer
823	FB2.PUNIT	4 Byte	Integer
824	FB3.P	8 Byte Signed (truncated to 4 Byte Signed)	Integer
826	FB3.PDIR	1 Byte	Integer
827	FB3.PIN	4 Byte	Integer
828	FB3.POFFSET	8 Byte Signed (truncated to 4 Byte Signed)	Position
830	FB3.POUT	4 Byte	Integer
831	FB3.PUNIT	4 Byte	Integer
832	HOME.MAXDIST	8 Byte Signed (truncated to 4 Byte Signed)	Position
834	IL.DIFOLD	4 Byte	Float
835	IL.MI2TWTRESH	1 Byte	Integer
836	IL.MIMODE	1 Byte	Integer
837	IP.RESET	Command	None
838	MOTOR.VOLTMIN	2 Byte	Integer
839	MOTOR.VOLTRATED	2 Byte	Integer
840	MOTOR.VRATED	4 Byte Signed	Float
843	SD.LOAD	Command	None
844	SD.SAVE	Command	None
845	SD.STATUS	1 Byte	Integer
846	VL.FBUNFILTERED	8 Byte Signed (truncated to 4 Byte Signed)	Velocity
848	WS.DISARM	Command	None
849	WS.FREQ	4 Byte	Float
850	WS.TDELAY4	2 Byte	Integer
851	WS.CHECKT	2 Byte	Integer

Instance	Parameter	Data Size	Data Type
852	WS.CHECKV	8 Byte Signed (truncated to 4 Byte Signed)	Velocity
859	AOUT.VSCALE	8 Byte (truncated to 4 Byte)	Velocity
861	WS.TSTANDSTILL	2 Byte	Integer
862	WS.TIRAMP	2 Byte	Integer
863	FB1.PMTSAVEEN	1 Byte	None
864	FB1.PMTBITS	1 Byte	None
865	MOTOR.IMTR	2 Byte	Integer
866	IL.FBSOURCE	1 Byte	Integer
867	MOTOR.IMID	4 Byte	Float
868	WS.CHECKMODE	1 Byte	Integer
869	REGEN.POWERFILTERED	8 Byte (truncated to 4 Byte)	Integer
8192	VBUS.VALUE	2 Byte	Integer
8193	STATUS3	1 Byte	Integer
8195	DIN.STATES	1 Byte	Integer

10 Appendix C: RSLogix 500

10.1 PLC & Drive TCP/IP Settings	85
10.2 Read Explicit Message Setup	86
10.3 Write Explicit Message Setup	88

10.1 PLC & Drive TCP/IP Settings

This section contains instructions for setting the PLC and Drive TCP/IP.

The following settings are recommended in the Channel Configuration window:

The screenshot shows the 'Channel Configuration' dialog box with the 'Channel 0' tab selected. The 'Driver' is set to 'Ethernet'. The 'Hardware Address' is 00:00:BC:67:92:9F. The 'IP Address' is 192.168.0.5, 'Subnet Mask' is 255.255.255.0, and 'Gateway Address' is 0.0.0.0. The 'Network Link ID' is 0. The 'Default Domain Name' is empty. The 'Primary Name Server' and 'Secondary Name Server' are both 0.0.0.0. The 'User Provided Web Pages' section has 'Starting Data File Number' set to 0 and 'Number of Pages' set to 1. The 'Protocol Control' section has 'HTTP Server Enable' checked, 'Auto Negotiate' checked, and 'Port Setting' set to '10/100 Mbps Full Duplex/Half Duplex'. Other options like 'BOOTP Enable', 'DHCP Enable', 'SNMP Server Enable', 'SMTP Client Enable', 'DNP3 over IP Enable', 'Modbus TCP Enable', 'Disable EtherNet/IP Incoming Connections', and 'Disable Duplicate IP Address Detection' are unchecked. The 'Msg Connection Timeout (x 1mS)' is 15000, 'Msg Reply Timeout (x 1mS)' is 3000, and 'Inactivity Timeout (x Min)' is 30. The 'Contact' and 'Location' fields are empty. The dialog has 'OK', 'Cancel', 'Apply', and 'Help' buttons at the bottom.

As seen above, enabling HTTP server support is recommended, with DHCP disabled. The AKD address can also be set using its rotary switches. For instructions, see the [WorkBench Online Help](#).

10.2 Read Explicit Message Setup

Displayed below is an example of a read ladder rung. The timer limits the read to every 50 ms.

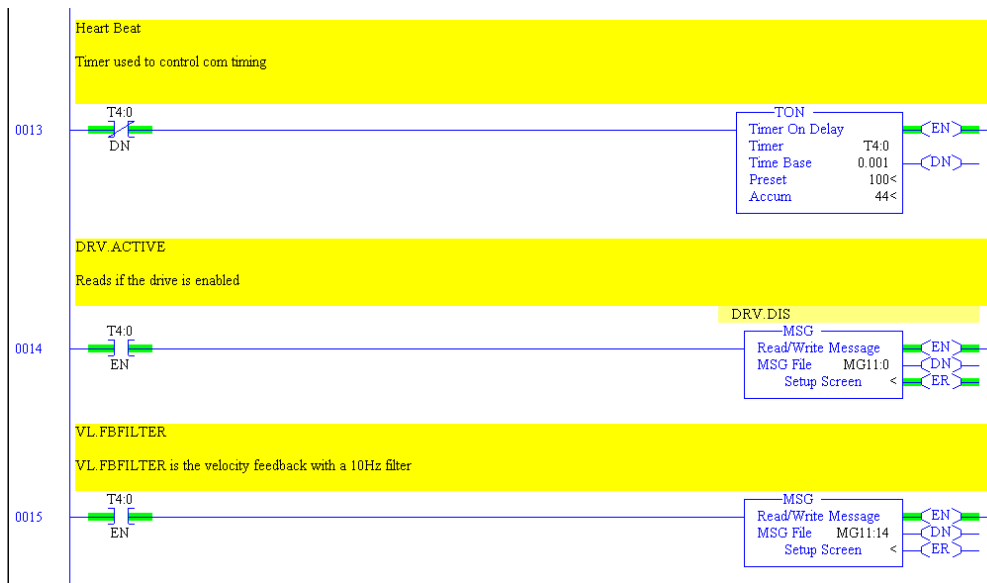

To setup a read explicit message, first create a MSG instruction, and set it to the following settings:

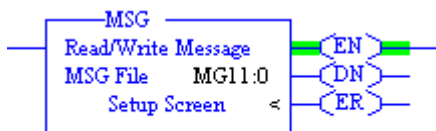

Next click on the MultiHop tab and enter the drive's IP address as seen below:

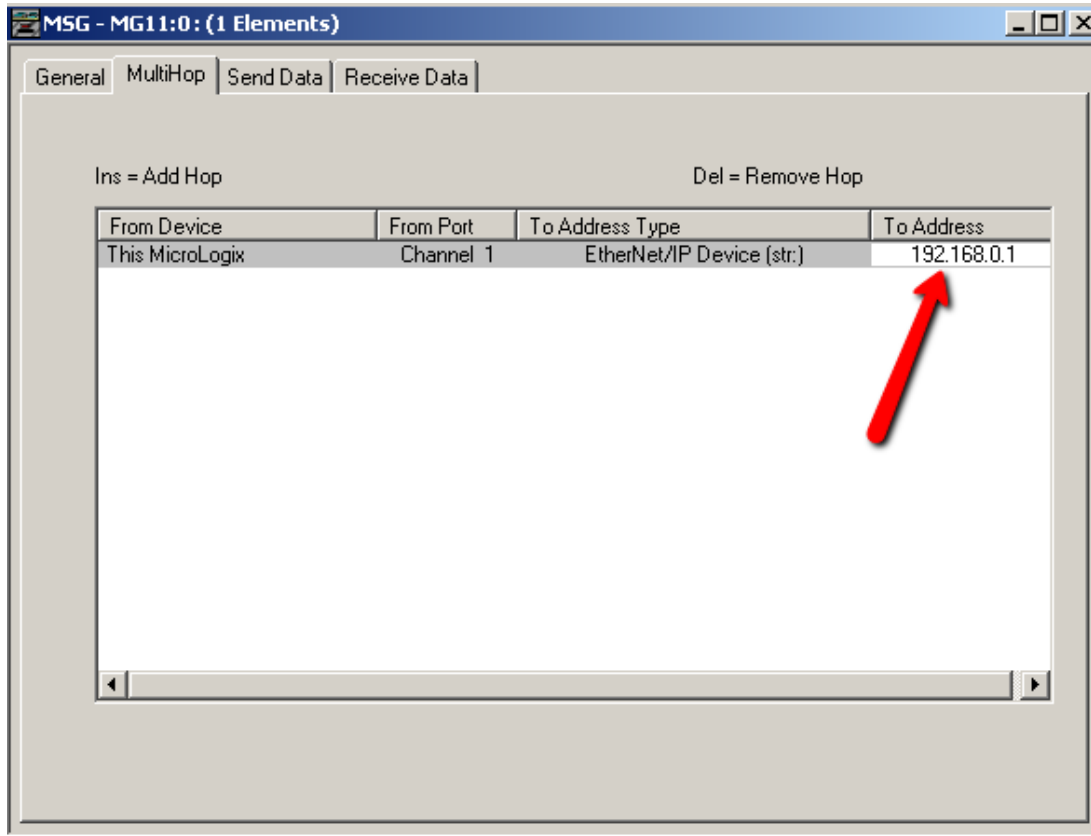

For 8 byte messages use two LONG data files (enter one and RSLogix will automatically use the second).

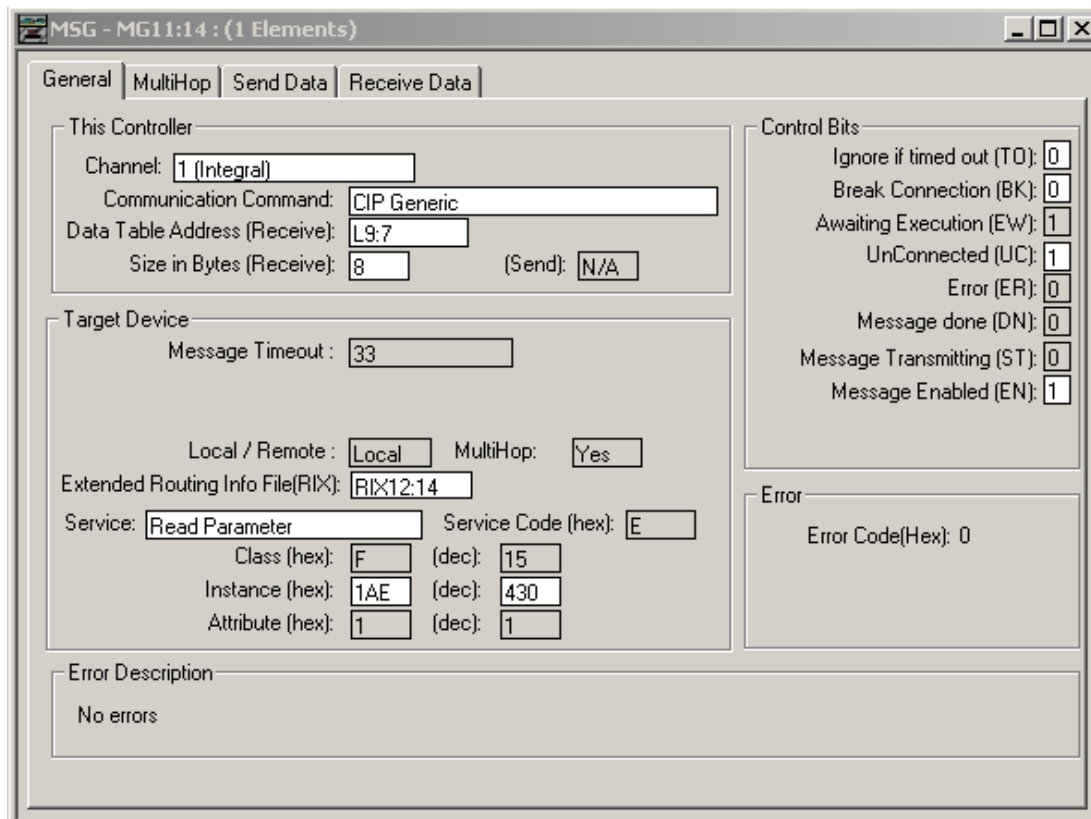

10.3 Write Explicit Message Setup

Displayed below is an example of a command write ladder. The "one shot" is to prevent the instruction from continuously writing to the parameter (commands don't require data but RSLogix 500 does require a data table address. The act of writing to the command parameter will trigger a response).

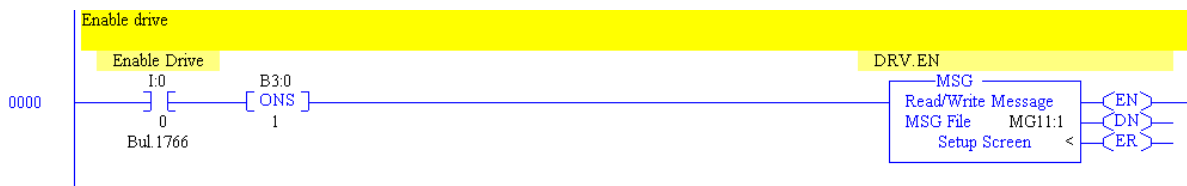

The following is an example of a 8 byte write ladder. The "one shot" is to prevent the instruction from continuously writing to the parameter. In this case, the drive parameter is 8 bytes so the data to be written is in L9:0 (LSB) & L9:1 (MSB).



To setup a write explicit message, first create a MSG instruction, and set it to the following settings:

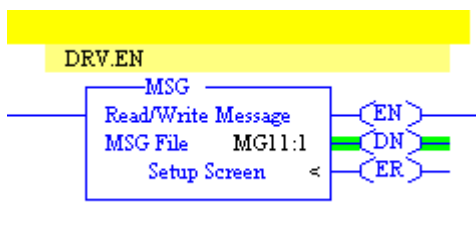

MSG - MG11:1 : (1 Elements)

General | MultiHop | Send Data | Receive Data

This Controller

Channel:

Communication Command:

(Send):

Size in Bytes (Receive): (Send):

Target Device

Message Timeout:

Local / Remote: MultiHop:

Extended Routing Info File(RIX):

Service: Service Code (hex):

Class (hex): (dec):

Instance (hex): (dec):

Attribute (hex): (dec):

Control Bits

Ignore if timed out (TO):

Break Connection (BK):

Awaiting Execution (EW):

UnConnected (UC):

Error (ER):

Message done (DN):

Message Transmitting (ST):

Message Enabled (EN):

Error

Error Code(Hex): 0

Error Description

No errors

Then click on the MultiHop tab and enter the drive's IP address as seen below:

MSG - MG11:1 : (1 Elements)

General | MultiHop | Send Data | Receive Data

Ins = Add Hop Del = Remove Hop

From Device	From Port	To Address Type	To Address
This MicroLogix	Channel 1	EtherNet/IP Device (str.)	192.168.0.1



About KOLLMORGEN

Kollmorgen is a leading provider of motion systems and components for machine builders. Through world-class knowledge in motion, industry-leading quality and deep expertise in linking and integrating standard and custom products, Kollmorgen delivers breakthrough solutions that are unmatched in performance, reliability and ease-of-use, giving machine builders an irrefutable marketplace advantage.



Join the [Kollmorgen Developer Network](#) for product support. Ask the community questions, search the knowledge base for answers, get downloads, and suggest improvements.

North America KOLLMORGEN

201 West Rock Road
Radford, VA 24141, USA

Web: www.kollmorgen.com
Mail: support@kollmorgen.com
Tel.: +1 - 540 - 633 - 3545
Fax: +1 - 540 - 639 - 4162

**Europe
KOLLMORGEN Europe GmbH**
Pempelfurtstr. 1
40880 Ratingen, Germany

Web: www.kollmorgen.com
Mail: technik@kollmorgen.com
Tel.: +49 - 2102 - 9394 - 0
Fax: +49 - 2102 - 9394 - 3155

South America KOLLMORGEN

Avenida João Paulo Ablas, 2970
Jardim da Glória, Cotia – SP
CEP 06711-250, Brazil

Web: www.kollmorgen.com
Mail: contato@kollmorgen.com
Tel.: +55 11 4615-6300
Fax: +1 - 540 - 639 - 4162

China and SEA KOLLMORGEN

Room 302, Building 5, Lihpao Plaza,
88 Shenbin Road, Minhang District,
Shanghai, China.

Web: www.kollmorgen.cn
Mail: sales.china@kollmorgen.com
Tel.: +86 - 400 668 2802
Fax: +86 - 21 6248 5367