

AKD[®] Central Power Supply Installation Manual



Edition: L, October 2021
Valid for AKD-C, Hardware Revision A
Part Number 903-200019-00
Original Document



For safe and proper use, follow these instructions. Keep for future use.



Functional Safety Type Approved
www.tuv.com
ID 0600000000



Record of Document Revisions

Revision	Remarks
...	Table with lifecycle information of this document see (→ # 96)
J, 10/2018	Layout of the warning notes updated, , user expertise updated, new readers note cover page, wording AKD-N/IP67 environment note
K, 10/2019	RoHS, EAC, chapter used standards removed
L, 10/2021	RJ45: Unified notation, STO input current corrected, package supplied (Safety Notes), chapter System Grounding new, chapter "Shielding on drive" improved, chapter "Approvals" restructured, PFH values updated

Hardware Revision (HR)

AKD-N	AKD-C	Firmware/ WorkBench	Export Classification	Remarks
A	A	from 1.11	3A225	AKD-C and AKD-N start revisions
B	A	from 1.13	-	AKD-N Hardware Revision for export classification traceability purposes
C	A	from 1.19	-	AKD-N usable for MKD-C for extended string size

Trademarks

- AKD is a registered trademark of Kollmorgen Corporation.
- EnDat is a registered trademark of Dr. Johannes Heidenhain GmbH.
- EtherCAT® is a registered trademark and patented technology, licensed by Beckhoff Automation GmbH, Germany.
- HIPERFACE is a registered trademark of Max Stegmann GmbH.
- SpeedTec is a registered trademark of TE Connectivity Industrial GmbH.
- Windows is a registered trademark of Microsoft Corporation.

Current patents

- US Patent 8.154.228 (Dynamic Braking For Electric Motors)
- US Patent 8.214.063 (Auto-tune of a Control System Based on Frequency Response)
- US Patent 8.566.415 (Safe Torque Off over network wiring)
- US Patent 9.634.863 (Patent Systems and methods for supporting two different protocols on a same physical connection)
- US Patent 10.374.468 (System and method for improved DC power line communication)

Patents referring to fieldbus functions are listed in the matching fieldbus manual.

Technical changes which improve the performance of the device may be made without prior notice!

This document is the intellectual property of Kollmorgen. All rights reserved. No part of this work may be reproduced in any form (by photocopying, microfilm or any other method) or stored, processed, copied or distributed by electronic means without the written permission of Kollmorgen.

1 Table of Contents

1 Table of Contents	4
2 General	8
2.1 About this Manual	9
2.2 Using the PDF Format	9
2.3 Notes for the Printed Edition (paper version)	9
2.4 Symbols Used	10
2.5 Abbreviations Used	11
3 Product Safety	12
3.1 You should pay attention to this	13
3.2 Use as Directed	15
3.3 Prohibited Use	16
3.4 Warning notes placed on the product	16
4 Product life cycle handling	17
4.1 Packaging	18
4.2 Transport	18
4.3 Storage	18
4.4 Installation, setup and normal operation	18
4.5 Decommissioning	19
4.5.1 Volatile and non-volatile memory	19
4.6 Maintenance and cleaning	19
4.7 Disassembly	19
4.8 System Repair	20
4.9 Disposal	20
5 Approvals	21
5.1 Conformance with EC Machinery Directive, Functional Safety	22
5.2 Conformance with EC Low Voltage and EMC Directives	22
5.3 Conformance with UL/cUL	23
5.3.1 UL Markings / Marquages UL	23
5.4 Conformance with EAC	24
5.5 Conformance with RoHS	24
5.6 Conformance with REACH	24
6 Package	25
6.1 Package Supplied	26
6.2 Nameplate	26
6.3 Part Number Scheme	27
7 Technical description and data	28
7.1 The AKD-C Central Power Supply	29
7.2 Mechanical Data	30
7.3 Electrical Data	30
7.4 Fusing	31
7.4.1 External power supply fusing	31
7.4.2 External regen resistor fusing	31
7.5 Ambient Conditions, Ventilation, and Mounting Position	31
7.6 Grounding System	32
7.7 Signal Inputs/Outputs	32
7.8 Connectors	33
7.9 Recommended Tightening Torques	33
7.10 Cable Requirements	33
7.11 Cable Length Definition	35
7.12 Dynamic Braking	36

7.13 Regen circuit	36
7.13.1 Functional description	36
7.13.2 Technical data	36
7.14 Switch-On and Switch-Off Behavior	37
7.14.1 Switch-on behavior in standard operation	37
7.14.2 Switch-off process, standard operation	38
7.15 Global Safe Torque Off (STO)	39
7.15.1 STO Safety instructions	39
7.15.2 Use as directed	40
7.15.3 Prohibited use	40
7.15.4 Safety characteristic data	40
7.15.5 Response Time	40
7.15.6 General information	41
7.15.7 Enclosure, wiring	42
7.15.8 Technical data and connection	43
7.15.9 Functional description	44
7.15.9.1 Signal diagram (sequence)	45
7.15.9.2 Functional test	45
7.15.9.3 Global STO application example with Safety Control	46
7.15.9.4 OSSD test pulses	46
7.16 Shock-hazard Protection	47
7.16.1 Leakage current	47
7.16.2 Residual current protective device (RCD)	47
7.16.3 Isolating transformers	47
7.17 LED Display	48
8 Mechanical Installation	49
8.1 Important Notes	50
8.2 Dimension Drawing	51
8.3 Mounting Example	52
9 Electrical Installation	53
9.1 Important Notes	54
9.2 Guide to Electrical Installation	55
9.3 EMI Noise Reduction	56
9.3.1 Recommendations for EMI noise reduction	56
9.3.2 System Grounding	57
9.3.3 Shielding connection to the device	59
9.3.3.1 Shield connection clamps for X12, X13, X14, X15, X16	59
9.3.3.2 Ethernet connectors X10, X11, X18	59
9.3.3.3 DC power connector X20A, X21A (cable CCNCN1)	59
9.3.3.4 Local fieldbus connectors X20B, X21B (cable CCNCN1)	59
9.4 System Topology of a Decentralized Servo System	60
9.4.1 System limits	60
9.4.2 Example for one AKD-C	60
9.4.3 Example for several AKD-C	61
9.5 Wiring	62
9.6 Connection Overview	63
9.6.1 Connector assignment	63
9.6.2 Connection diagram	64
9.7 Electrical Supply Connection	65
9.7.1 Connection to various mains supply networks	65
9.7.2 Mains supply connection (X12)	66
9.7.2.1 Three phase connection	66
9.7.3 24 VDC supply voltage (X13)	67
9.8 DC Bus link (X14)	68

9.8.1 Regen resistor (X14)	69
9.8.1.1 Internal regen resistor	69
9.8.1.2 External regen resistor	69
9.8.2 Capacitor Modules (X14)	70
9.8.2.1 Technical Data	70
9.8.2.2 Example installation with KCM-S and KCM-E	71
9.8.2.3 Example installation with KCM-P and KCM-E	72
9.8.2.4 Discharging KCM modules	73
9.9 Drive String Connection	74
9.9.1 String assignment	75
9.9.2 DC power (X20A, X21A)	76
9.9.3 Local Fieldbus (X20B, X21B)	76
9.10 I/O Connection	77
9.10.1 I/O connectors X15 and X16	77
9.10.2 Digital Input (ENABLE, X15)	78
9.10.3 Digital Output (X15)	79
9.10.4 FAULT relay contacts	80
9.10.5 STO signals (X16)	80
9.11 Motion Bus Interface (X10/X11)	81
9.11.1 Pinout	81
9.11.2 Bus Protocols	81
9.11.3 Network configuration	81
9.11.4 EtherCAT	81
9.12 Service Interface (X18)	82
9.12.1 Pinout	82
9.12.2 Service Bus Protocols	82
9.12.3 Possible Network Configurations	82
9.13 Push-button (B1)	83
9.14 Rotary Switches (S1), Setting IP address	83
10 Setup	84
10.1 Important Notes	85
10.2 WorkBench Installation	86
10.2.1 Use as directed	86
10.2.2 Software description	87
10.2.3 Hardware requirements	87
10.2.4 Operating systems	87
10.2.5 Installation under Windows	88
10.3 Initial System Test	89
10.3.1 Unpacking, mounting, and wiring	89
10.3.2 Set IP address	89
10.3.3 Confirm connections	89
10.3.4 Install and start WorkBench	90
10.3.5 Enable the drive using the setup wizard	90
10.4 Fault and Warning Messages	91
10.5 Troubleshooting the AKD-C	92
11 Index	94
12 Record of Document Revisions	96

---/---

2 General

2.1 About this Manual	9
2.2 Using the PDF Format	9
2.3 Notes for the Printed Edition (paper version)	9
2.4 Symbols Used	10
2.5 Abbreviations Used	11

2.1 About this Manual

This manual, *AKD-C Installation Manual* ("Instructions Manual" according to EC Machinery Directive 2006/42/EU), describes the AKD-C (Central Power Supply) and includes information needed to safely install decentral drive system with an AKD-C and several AKD-N drives. A digital version of this manual (pdf format) is available on the DVD included with your device. Manual updates can be downloaded from the Kollmorgen website (www.kollmorgen.com).

AKD-C information for use consists of:

- *AKD-C Installation Manual*: describes the AKD-C (Central Power Supply) and includes information needed to safely install decentral drive system with an AKD-C.
- *Decentralized Drive System Project Guide*: describes how to build a decentralized drive system with AKD-C and AKD-N. It provides tips for system topology, cooling, and maximizing the system performance.
- *AKD-N Installation Manual*: describes the AKD-N series of drives for Kollmorgen decentralized drive system and includes information needed for safe assembling and installation of the drives.
- *WorkBench Online Help*: describes how to use your drive in common applications. It also provides tips for maximizing your system performance. The *Online Help* includes the *Parameter and Command Reference Guide* which provides documentation for the parameters and commands used to program the drive.
- *EtherCAT Communication*: describes how to use your system in EtherCAT applications.
- *Accessories Manual*: it provides documentation for accessories like cables and regen resistors used with AKD-C and AKD-N. Regional variants of this manual exist.

2.2 Using the PDF Format

This document includes several features for ease of navigation

Cross References	Table of contents and index include active cross references.
Table of contents and index	Lines are active cross references. Click on the line and the appropriate page is accessed.
Page/chapter numbers in the text	Page/chapter numbers with cross references are active links.

2.3 Notes for the Printed Edition (paper version)











A printed version of the manual is enclosed with each product. For environmental reasons, the document was reduced in size and printed on DIN A5.

NOTE











Should you experience difficulties reading the font size of the scaled-down printed version, you can print and use the PDF version in DIN A4 format 1:1. You can find the PDF version on the DVD accompanying the product and on the Kollmorgen website.

2.4 Symbols Used

Warning Symbols

Symbol	Indication
	Indicates a hazardous situation which, if not avoided, will result in death or serious injury.
	Indicates a hazardous situation which, if not avoided, could result in death or serious injury.
	Indicates a hazardous situation which, if not avoided, could result in minor or moderate injury.
	Indicates situations which, if not avoided, could result in property damage.
	This symbol indicates important notes.
	Warning of a danger (general). The type of danger is specified by the text next to the symbol.
	Warning of danger from electricity and its effects.
	Warning of danger from hot surface.
	Warning of danger from suspended loads.
	Warning of danger from automatic start.

Drawing symbols

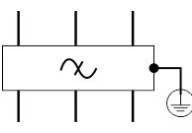
Symbol	Description	Symbol	Description
	Signal ground		Diode
	Chassis ground		Relay
	Protective earth		Relay switch off delayed
	Resistor		Normally open contact
	Fuse		Normally closed contact
	State-of-the-art firewall		EMC filter

2.5 Abbreviations Used

Abbreviation	Meaning
(→ # 53)	"see page 53" in this document
CE	Communauté Européenne
COM	Serial interface for a personal computer
DCOM	Communication line for digital inputs
Disk	Magnetic storage (diskette, hard disk)
EEPROM	Electrically erasable programmable memory
EMC	Electromagnetic compatibility
KAS	Kollmorgen Automation Suite
KAS IDE	Setup software (Kollmorgen Automation Suite Integrated Development Environment)
LED	Light-emitting diode
LSB	Low significant byte (or bit)
MSB	Main significant byte (or bit)
NI	Zero pulse
OSSD	Output signals Switching Device
PC	Personal computer
PE	Protective earth
PELV	Protective extra low voltage
PLC	Programmable logic control
PWM	Pulse-width modulation
RAM	Random access memory (volatile memory)
RBrake/RB	Regen resistor (also called a brake resistor)
RBext	External regen resistor
RBint	Internal regen resistor
RCD	Residual current device
RES	Resolver
ROD	Incremental encoder (A quad B)
STO	Safe torque off
VAC	Volts, alternating current
VDC	Volts, direct current

3 Product Safety

To avoid possible damage, read and follow the instructions.

3.1 You should pay attention to this	13
3.2 Use as Directed	15
3.3 Prohibited Use	16
3.4 Warning notes placed on the product	16

3.1 You should pay attention to this

This section helps you to recognize and avoid dangers to people and objects.

Specialist staff required!

The devices are intended for industrial applications. Machine builders must employ qualified personnel. Qualified personnel are people who have been trained to transport, install, commission and operate electrical drives.

- Transport, storage, unpacking: only by personnel with knowledge of handling electrostatically sensitive components.
- Mechanical installation: only by personnel with mechanical expertise.
- Electrical installation: only by personnel with expertise in electrical engineering.
- Basic tests / setup: only by personnel with expertise in electrical engineering and drive technology.

The qualified personnel must know and observe ISO 12100 / IEC 60364 / IEC 60664 and national accident prevention regulations.

Read the documentation!

Read the available documentation before installation and commissioning. Improper handling of the devices can cause harm to people or damage to property. The operator of systems using the drive system must ensure that all personnel who work with the drive read and understand the manual before using the drive.

Check Hardware Revision!

Check the Hardware Revision Number of the product (see product label). This number is the link between your product and the manual. The product Hardware Revision Number must match the Hardware Revision Number on the cover page of the manual.

Pay attention to the technical data!

Adhere to the technical data and the specifications on connection conditions. If permissible voltage values or current values are exceeded, the devices can be damaged. Unsuitable motor or wrong wiring will damage the system components. Check the combination of drive and motor. Compare the rated voltage and current of the units.

Perform a risk assessment!

The manufacturer of the machine must generate a risk assessment for the machine, and take appropriate measures to ensure that unforeseen movements cannot cause injury or damage to any person or property. Additional requirements on specialist staff may also result from the risk assessment.

Automatic Restart!

The drive might restart automatically after power on, voltage dip or interruption of the supply voltage, depending on the parameter setting.

Risk of death or serious injury for humans working in the machine.

If the parameter DRV.ENDEFAULT for one AKD-N is set to 1, then place a warning sign to the machine (Warning: Automatic Restart at Power On) and ensure, that power on is not possible, while humans are in a dangerous zone of the machine. In case of using an under-voltage protection device, you must observe EN 60204-1:2006 chapter 7.5 .



Observe electrostatically sensitive components!

The devices contain electrostatically sensitive components which may be damaged by incorrect handling. Electrostatically discharge your body before touching the device. Avoid contact with highly insulating materials (artificial fabrics, plastic film etc.). Place the device on a conductive surface.

Earthing!

It is vital that you ensure that the drive is safely earthed to the PE (protective earth) busbar in the switch cabinet. Risk of electric shock. Without low-resistance earthing no personal protection can be guaranteed.

**Leakage Current!**

Since the leakage current to PE is more than 3.5 mA, in compliance with IEC61800-5-1 the PE connection must either be doubled or a connecting cable with a cross-section $>10 \text{ mm}^2$ must be used. Deviating measures according to regional standards might be possible.

Residual current protective or monitoring devices!

AKD-C with AKD-N can cause a d.c. current in the protective earthing conductor. Where a residual current-operated protective (RCD) or monitoring (RCM) device is used for protection in case of direct or indirect contact, only an RCD or RCM of Type B is allowed on the supply side of AKD-C.

Lethal voltages!

The equipment produces high electric voltages up to 900V. Do not open or touch the equipment during operation. Keep all covers closed.

During operation, AKD-C may have uncovered live sections, according to their level of enclosure protection.

Lethal danger exists at live parts of the device. Built-in protection measures such as insulation or shielding may not be removed. Work on the electrical installation may only be performed by trained and qualified personnel, in compliance with the regulations for safety at work, and only with switched off mains supply, and secured against restart.

Never undo any electrical connections to the AKD-C while it is live. There is a danger of electrical arcing with damage to contacts and personal injury. Wait at least 7 minutes after disconnecting the product from the supply voltages (mains supply and 24V supply) before touching potentially live sections of the equipment (such as contacts) or removing any connections.

Always measure the voltage in the DC bus link at connector X14 and wait until the voltage is below 50 V before handling components.

Functional Safety

The STO safety implementation on the AKD is certified. The assessment of the safety functions according to EN13849 or EN 62061 must finally be done by the user. Serious injury could result when a suspended load is not properly blocked. Functional safety requires and additional, external mechanical brake, operated by a safety controller.

Never modify the drive!

It is not allowed to modify the drive hardware without permission by the manufacturer. Opening the housing causes loss of warranty.



3.2 Use as Directed

The AKD-C series power supplies are exclusively intended for operating AKD-N series drives within a decentralized drive system.

AKD-C are components that are built into electrical plants or machines and can only be operated as integral components of these plants or machines. The manufacturer of the machine must generate a risk assessment for the machine.

When the devices are built into machines or plant, the drive must not be used until it has been established that the machine or plant fulfills the requirements of the regional directives.

Kollmorgen Decentralized Drive System

AKD-C series power supply must only be operated in a motion system with components from Kollmorgen. Required additional Kollmorgen components are the "near servo drives" AKD-N, hybrid cables, motor power and feedback cables, servomotors.

Assembling

AKD-C devices must only be operated in environments suitable for the ambient conditions defined on (→ # 31) . Observe the information given in the *Decentralized System Project Guide*.

Wiring

Use only Kollmorgen CCNxN1 series of hybrid cables for connecting AKD-N and AKD-C devices.

Power supply

AKD-C must be powered from a 3 phase industrial supply network (not more than 42 kA symmetrical rated current at 400 V and 480 V).

For the cases of group installations and of DC powered drives

NOTICE

AKD has not been evaluated by Kollmorgen, UL, or TÜV for group installations nor are ratings defined for DC input voltage.

Group installations must be reviewed and evaluated by the user for branch circuit protection*, wire size, wire voltage rating, fuse protection, system dielectric requirements, over-voltage and input** current rating.

In case of DC supplied drives the built-in EMC filter will not work. The user is responsible to keep the conducted emissions and the immunity of the drive within the required noise levels.

* Special care must be taken in branch circuit design with mixed rating drives to avoid the smaller drives becoming the effective 'fuse' rather than the circuit protective fuse.

** The power supply system design must ensure inrush current protection by limiting input current during power up. DC supply polarity must be properly wired. Improper polarity of DC power will damage the drive and void warranty.

Auxiliary voltage supply, Standby power

Standby power for the drive strings must only be used for supplying the AKD-N electronics. 24 VDC supply unit must accord to PELV (EN 60204-1) requirements.

Safe torque off

Review the section "Use as Directed" in the STO chapter (→ # 39) before using this safety function (SIL2, PLd, category 3 according to ISO 13849).

24 VDC supply unit for global STO supply must accord to PELV (EN 60204-1) requirements.

3.3 Prohibited Use

Other use than that described in chapter “Use as directed” is not intended and can lead to personnel injuries and equipment damage.

The device may not be used

- with a machine that does not comply with appropriate national directives or standards,
- for driving elevators,
- in applications with continuous, operational short circuits to the external regen resistor contacts.
- in applications with any short circuits to the DC-Bus link contacts.

The use of the device in the following environments is also prohibited:

- potentially explosive areas
- environments with corrosive and/or electrically conductive acids, alkaline solutions, oils, vapors, dusts
- ships or offshore applications

Wiring the system with hybrid cables from other manufacturers than Kollmorgen is not allowed. Changing Kollmorgen cables or connectors is not allowed.

3.4 Warning notes placed on the product

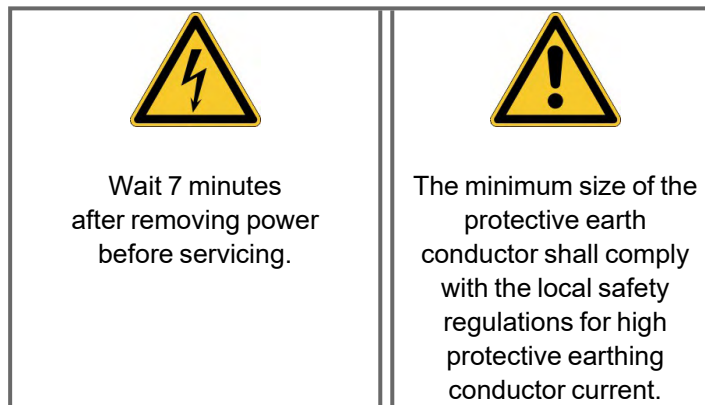

NOTICE

If these signs are damaged, they must be replaced immediately.

4 Product life cycle handling

4.1 Packaging	18
4.2 Transport	18
4.3 Storage	18
4.4 Installation, setup and normal operation	18
4.5 Decommissioning	19
4.6 Maintenance and cleaning	19
4.7 Disassembly	19
4.8 System Repair	20
4.9 Disposal	20

4.1 Packaging

The AKD-C packaging consists of recyclable cardboard with inserts and a label on the outside of the box.

Model	Package Dimensions (mm) HxWxL	Total Weight (kg)
AKD-C01007	125 x 410 x 295	5

4.2 Transport

Transport the device in accordance with IEC 61800-2 as follows:

- Transport only by qualified personnel in the manufacturer's original recyclable packaging.
- Avoid shocks while transporting.
- Store at or below maximum stacking height of 8 cartons
- Transport only within specified temperature ranges: -25 to +70 °C, max. rate of change 20 K/hour, class 2K3.
- Transport only within specified humidity: maximum 95% relative humidity, no condensation, class 2K3.

NOTICE

The devices contain electrostatically sensitive components that can be damaged by incorrect handling. Electrostatically discharge yourself before touching the device. Avoid contact with highly insulating materials, such as artificial fabrics and plastic films. Place the device on a conductive surface.

If the packaging is damaged, check the unit for visible damage. Inform the shipper and the manufacturer of any damage to the package or product.

4.3 Storage

Store the device in accordance with IEC 61800-2 as follows:

- Store only in the manufacturer's original recyclable packaging.
- Store at or below maximum stacking height of 8 cartons
- Store only within specified temperature ranges: -25 to +55 °C, max. rate of change 20 K/hour, class 1K4.
- Storage only within specified humidity: 5 to 95% relative humidity, no condensation, class 1K3.
- Store in accordance with the following duration requirements:
 - Less than 1 year: without restriction.
 - More than 1 year: capacitors must be re-formed before setting up and operating the drive. Re-forming procedures are described in the Kollmorgen Developer Network ([Forming](#)).

4.4 Installation, setup and normal operation

Installation and setup information are given in this manual:

- Mechanical installation (→ # 49)
- Electrical installation (→ # 53)
- Setup (→ # 84)

Normal operation tested for environmental class 3K3 according to IEC 61800-2 (→ # 31). The manufacturer of the machine defines the necessary end user expertise based on the risk assessment for the machine and describes the requirements for normal operation based on the application.

4.5 Decommissioning

NOTICE

Only professional staff who are qualified in electrical engineering are allowed to decommission parts of the system.

DANGER: Lethal Voltages!

There is a danger of serious personal injury or death by electrical shock or electrical arcing.

- Switch off the main switch of the switchgear cabinet.
- Secure the system against restarting.
- Block the main switch.
- Wait at least 7 minutes after disconnecting.

4.5.1 Volatile and non-volatile memory

[Letter of Volatility for AKD Drives](#): This letter of volatility describes volatile and non-volatile media as well as storage media on the AKD. Customers can use this document to comply with security requirements.

4.6 Maintenance and cleaning

The device does not require maintenance, it should be inspected once a year by professional staff.

NOTICE

Do not immerse or spray the device. Avoid that liquid enters the device. The inside of the unit can only be cleaned by the manufacturer. Opening the device voids the warranty.

To clean the device exterior:

1. Decommission the device (see chapter 4.5 "Decommissioning").
2. Casing: Clean with Isopropanol or similar cleaning solution.

Caution : Highly Flammable! Risk of injury by explosion and fire.

- Observe the safety notes given on the cleaning liquid package.
 - Wait at least 30 minutes after cleaning before putting the device back into operation.
3. Protective grill on fan: Clean with a dry brush.

4.7 Disassembly

NOTICE

Only professional staff who are qualified in electrical engineering are allowed to disassemble parts of the system.

1. Decommission the device (see chapter 4.5 "Decommissioning").
2. Remove the connectors. Disconnect the potential earth connection last.
3. Demount: loosen the fastening screws. Remove the device.

4.8 System Repair

NOTICE

Only professional staff who are qualified in electrical engineering are allowed to exchange parts of the drive system.

CAUTION: Automatic Start! During replacement work a combination of hazards and multiple episodes may occur.

- Work on the electrical installation may only be performed by trained and qualified personnel, in compliance with the regulations for safety at work, and only with use of prescribed personal safety equipment.

Exchange of the device

Only the manufacturer can repair the device. Opening the device voids the warranty.

1. Decommission the device (see chapter 4.5 "Decommissioning").
2. Demount the device (see chapter 4.7 "Disassembly").
3. Send the device to the manufacturer.
4. Install a new device as described in the Installation Manual.
5. Setup the system as described in the Installation Manual.

Exchange of other drive system parts

If parts of the drive system (for example cables) must be replaced, proceed as follows:

1. Decommission the device (see chapter 4.5 "Decommissioning").
2. Exchange the parts.
3. Check all connections for correct fastening.
4. Setup the system as described in the Installation Manual.

4.9 Disposal

NOTICE

To dispose the unit properly, contact a certified electronic scrap disposal merchant.

In accordance with the WEEE-2012/19/EU guideline and similar, the manufacturer accepts returns of old devices and accessories for professional disposal. Transport costs are the responsibility of the sender.

Send the devices in the original packaging to the manufacturer address:

North America KOLLMORGEN 201 West Rock Road Radford, VA 24141, USA	South America KOLLMORGEN Avenida João Paulo Ablas, 2970 Jardim da Glória, Cotia – SP CEP 06711-250, Brazil
Europe KOLLMORGEN Europe GmbH Pempelfurtstr. 1 40880 Ratingen, Germany	Asia KOLLMORGEN Room 302, Building 5, Lihpao Plaza, 88 Shenbin Road, Minhang District, Shanghai, China.

5 Approvals

5.1	Conformance with EC Machinery Directive, Functional Safety	22
5.2	Conformance with EC Low Voltage and EMC Directives	22
5.3	Conformance with UL/cUL	23
5.4	Conformance with EAC	24
5.5	Conformance with RoHS	24
5.6	Conformance with REACH	24

5.1 Conformance with EC Machinery Directive, Functional Safety

Conformance with the EC Machinery Directive 2006/42/EU is mandatory for the supply of safety components within the European Community. The STO safety implementation on the AKD is certified by TÜV. The safety circuit implementation used for the safety function "Safe Torque Off" in the drives is suited for SIL 2 according to IEC 62061 and PLd / CAT3 according to ISO 13849-1.

Safe Torque Off (STO) string type (global)

Structure	STO	ISO 13849-1	MTTF _d	IEC 62061	PFH [1/h]	SFF [%]	T _M [Years]
AKD-C + 1 x AKD-N	global	PL d, CAT 3	≥ 100	SIL 2	2.99E-08	97.08	20
AKD-C + 8 x AKD-N	global	PL d, CAT 3	≥ 100	SIL 2	3.07E-08	99.44	20

Safe Torque Off (STO) single drive type (local)

Structure	STO	ISO 13849-1	MTTF _d	IEC 62061	PFH [1/h]	SFF [%]	T _M [Years]
1 x AKD-N-DS/DT	local	PL d, CAT 3	≥ 100	SIL 2	2.9E-08	97.12	20

See *AKD-N Installation Manual* for detailed information.

5.2 Conformance with EC Low Voltage and EMC Directives

EU Declarations of Conformity can be found on the [Kollmorgen website](#).

Conformance with the EC EMC Directive 2014/30/EU and the Low Voltage Directive 2014/35/EU is mandatory for the supply of drives within the European Community.

The devices have been tested by an authorized testing laboratory in a defined configuration, using the system components that are described in this documentation. Any divergence from the configuration and installation described in this documentation means that the user will be responsible for carrying out new measurements to ensure conformance with regulatory requirements.

The AKD-C01007 meet the noise immunity requirements to the 2nd environmental category (industrial environment). For noise emission the AKD-C01007 meet the requirement to a product of the Category C2.

NOTICE

These devices can cause high-frequency interferences in non industrial environments and may require measures for interference suppression (such as additional external EMC filters).

5.3 Conformance with UL/cUL

This device is listed under UL (Underwriters Laboratories Inc.) file number **E217428**. UL Markings are combined for both AKD-C and AKD-N in one section.

5.3.1 UL Markings / Marquages UL

English	Français
<ul style="list-style-type: none"> This product is suitable for use on a circuit capable of delivering not more than 42,000 rms symmetrical amperes, 480 V maximum. 	<ul style="list-style-type: none"> <i>Ce produit est conçu pour une utilisation sur un circuit capable de fournir 42.000 ampères symétriques (rms) maximum pour 480 V maximum.</i>
<ul style="list-style-type: none"> Maximum surrounding air temperature 40°C. 	<ul style="list-style-type: none"> <i>La température maximale de l'air ambiant de 40°C.</i>
<ul style="list-style-type: none"> AKD-C are intended to be used in a pollution degree 2 environment. 	<ul style="list-style-type: none"> <i>AKD-C sont prévus pour une utilisation dans un environnement de pollution de niveau 2.</i>
<ul style="list-style-type: none"> AKD-C : Use 60/75°C copper wire only. 	<ul style="list-style-type: none"> <i>AKD-C: Utilisez seulement un fil cuivre 60/75°C.</i>
<ul style="list-style-type: none"> AKD-C : CAUTION Risk of Electrical Shock! Capacitors can have dangerous voltages present up to 7 minutes after switching off the supply power. For increased safety, measure the voltage in the DC bus link and wait until the voltage is below 50 V. 	<ul style="list-style-type: none"> AKD-C : ATTENTION: Risque de choc électrique! Des tensions dangereuses peuvent persister dans les condensateurs jusqu'à 7 minutes après la mise hors tension. Pour plus de sécurité, mesurez la tension dans la liaison de bus CC et attendez qu'elle soit inférieure à 50 V.
<ul style="list-style-type: none"> For use in Canada: Transient surge suppression shall be installed on the line side of this equipment and shall be rated 277 V (phase to ground), 480 V (phase to phase), suitable for overvoltage category III, and shall provide protection for a rated impulse withstand voltage peak of 2 kV. 	<ul style="list-style-type: none"> <i>Pour utilisation au Canada: Suppression de surtension transitoire doit être installé sur le côté de la ligne de ce matériel et doit être évalué 277 V (phase à terre) , 480 V (entre phases) , adapté à la catégorie de surtension III , et doit fournir une protection pour un choc nominale supporter la tension de crête de 2 kV.</i>

- The following fuse types are recommended for branch circuit protection for AKD-C01007-CBXX:
Les types de fusibles suivants sont recommandés pour protection de secteur pour AKD-C01007-CBXX:

Model/ Modèle	Class/ Classe	Voltage Rating/ Niveau de tension	Max. Fuse&SCC Rating/ Niveau maximum & SCC
Nonrenewable Cartridge fuse	CC, J	600 VAC	20 A, 200 kA

- The following table illustrates the torque requirements for the field wiring connectors :
Le tableau suivant indique les spécifications de couple pour les connecteurs de câblage sur site:

Model/Modèle	Torque/Couple serrage, LB IN (Nm)	Wire size/Section de fil, AWG (mm ²)
AKD-C X12	6.2 - 7.1 (0.7 - 0.8)	12 - 8 (4 - 10)
AKD-C X20A	6.2 - 7.1 (0.7 - 0.8)	12 - 8 (4 - 10)
AKD-C X21A	6.2 - 7.1 (0.7 - 0.8)	12 - 8 (4 - 10)
AKD-C X14	6.2 - 7.1 (0.7 - 0.8)	12 - 8 (4 - 10)
AKD-C X13	1.8 - 2.2 (0.2 - 0.25)	14 - 12 (2.5 - 4)
AKD-C X15	1.8 - 2.2 (0.2 - 0.25)	20 - 18 (0.5 - 0.8)
AKD-C X16	1.8 - 2.2 (0.2 - 0.25)	20 - 18 (0.5 - 0.8)

- Split gage of AKD-N screwed connectors: max. 2.8 mm.
Le gage de split des connecteurs vissé d'AKD-N: 2,8 mm max.
- Cold plate for AKD-N: at 40°C surrounding air temperature and 680 VDC supply voltage:
Plaque froide pour AKD-N: à température ambiante 40°C et tension d'alimentation 680 VDC:
 - AKD-N00307: 240 mm x 240 mm x 10 mm or equivalent (LxWxT, Aluminum cold plate, uncoated)
 - AKD-N00607: 500 mm x 500 mm x 10 mm or equivalent (LxWxT, Aluminum cold plate, uncoated)
 - AKD-N01207: 480 mm x 400 mm x 84 mm or equivalent (LxWxT, 31 vertical fins, Aluminum heat sink, uncoated)

5.4 Conformance with EAC

EAC is the abbreviation for Eurasian Conformity. The mark is used in the states of the Eurasian Customs Union (Russia, Belarus, Kazakhstan) similar to the European CE mark.

Kollmorgen declares, that the device has passed all required conformity procedures in a member state of the Eurasian Customs Union, and that the device meets all technical requirements requested in the member states of the Eurasian Customs Union:

- Low voltage (TP TC 020/2011)
- Electromagnetic Compatibility (TP TC 004/2011)

Contact: SERVOSTAR LLC. , Bld.1, Semyonovskaya nab. 2/1, RU-105094 Moskau

5.5 Conformance with RoHS

The device is manufactured in conformance with RoHS Directive 2011/65/EU with delegated directive 2015/863/EU for installation into a machine.

5.6 Conformance with REACH

EU Regulation no. 1907/2006 deals with the registration, evaluation, authorization and restriction of chemical substances 1 (abbreviated to "REACH").

The device does not contain any substances (CMR substances, PBT substances, vPvB substances and similar hazardous substances stipulated in individual cases based on scientific criteria) above 0.1 mass percent per product that are included on the candidate list.

6 Package

6.1 Package Supplied	26
6.2 Nameplate	26
6.3 Part Number Scheme	27

6.1 Package Supplied

When a device from the AKD-C series is ordered, the following items are included in the package:

- AKD-C
- Printed copy of *AKD-C/N Safety Notes*
- DVD containing the setup software, WorkBench, and all product documentation in digital format.
- Mating connectors X12, X13, X14, X15, X16
- Two connector covers M23

NOTE

The M23 connector covers are required for protecting X2 of the last AKD-N in the strings.

Accessories Sold Separately

Accessories must be ordered separately if required; refer to your regional accessories manual:

- Hybrid cables for connection to first AKD-N
- External regen resistor
- EtherCAT cable to the network
- Power cable, control wires
- Cabinet grommets
- Slip rings







Spare parts

Spare parts are described in the regional accessories manual:

- Connector Kit (X12...16)
- Shield clamp SK14

6.2 Nameplate

The nameplate depicted below is attached to the side of the device. Picture similar to the nameplate on the device.

KOLLMORGEN	Customer Support: North America: +1 (540) 633-3400 Europe: +49 (0) 2102-9394-0 Italy: +39 (0) 362-594260	HW Rev: A  RoHS	
Pempelfurtstr. 1 40880 Ratingen Germany			
Model No: AKD-C01007-CBEC-D000			
			
Serial No: R-1241-00003			
			
MAC Address: 00-23-1B-00-70-3C			
  			
	Control Circuit	Input-Main	Output DC-Bus
Voltage	24 Vdc	400/480 Vac	565-680 Vdc
Frequency		50/60 Hz	dc
Phase		3 Ph	-
FL Current	14 A	14 Arms	17 Adc
Power @ 480 Vac		11 kVA	11 kW
Surrounding Air Temperature: Max. 40 °C		SCCR: 42 kA	
Enclosure Protection Rating: IP 20			
Before use, refer to DVD for installation and safety information.			
Assembled in Germany		Patents Pending www.kollmorgen.com	

6.3 Part Number Scheme

Use the part number scheme for product identification only, not for the order process, because not all combinations of features are possible, always.

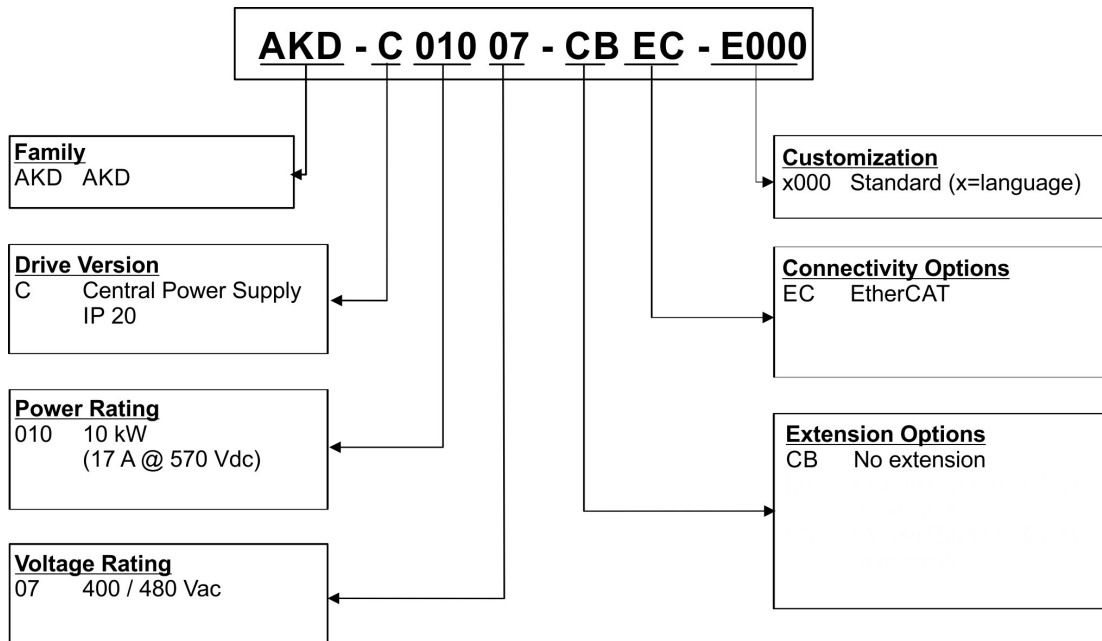

Customization code includes language version of printed material and not safety relevant customer specials.

7 Technical description and data

7.1 The AKD-C Central Power Supply	29
7.2 Mechanical Data	30
7.3 Electrical Data	30
7.4 Fusing	31
7.5 Ambient Conditions, Ventilation, and Mounting Position	31
7.6 Grounding System	32
7.7 Signal Inputs/Outputs	32
7.8 Connectors	33
7.9 Recommended Tightening Torques	33
7.10 Cable Requirements	33
7.11 Cable Length Definition	35
7.12 Dynamic Braking	36
7.13 Regen circuit	36
7.14 Switch-On and Switch-Off Behavior	37
7.15 Global Safe Torque Off (STO)	39
7.16 Shock-hazard Protection	47
7.17 LED Display	48

7.1 The AKD-C Central Power Supply

Available AKD versions

Variant	Description	Power	Connectivity
AKD-C01007-CBEC	Central Power supply without extension.	10 kW	EtherCAT

Standard features

- Supply voltage range 400 V to 480 V $\pm 10\%$.
- Mains EMC filter and 24 V EMC filter integrated.
- EtherCAT bus onboard.
- TCP/IP service channel 100 Mbit/s onboard.
- Safe Torque Off (STO) according to IEC 62061 SIL 2 onboard.
- Supports up to 16 AKD-N drives.

Power section

- Three phase supply, maximum voltage range 360 to 528 V, 47 to 65 Hz.
- B6 bridge rectifier, integral soft-start circuit.
- Fusing to be provided by the user.
- Shielding star point close to the device.
- DC power split to two connectors (strings) for up to 16 drives.
- DC power voltage range 565 to 680 VDC, DC bus output current max 17 A.
- Standby DC power voltage 55 VDC $\pm 10\%$ (generated from 24 VDC voltage supply)
- Regen circuit for all connected AKD-N.
- Built-in regen resistor, external regen resistor or capacitor module if required.

Integrated safety

- Appropriate insulation/creepage distances and electrical isolation for safe electrical separation, per IEC 61800-5-1, between the power input/DC bus connections and the signal electronics.
- Soft-start, overvoltage detection, short-circuit protection, phase-failure monitoring.
- Temperature monitoring.
- SIL 2 safe torque off in accordance with IEC 62061 , (→ # 39).

Supply voltage 24V DC (electronic supply and standby voltage)

- From an external, safety approved 24 V $\pm 10\%$ power supply, minimum 480 W.

Operation and parameter setting

- Using the setup software WorkBench for setup via TCP/IP.

Inputs/Outputs

- 1 programmable digital output (→ # 79)
- 1 fault relay output (→ # 80)
- 1 Enable input (→ # 78)
- 2 STO inputs (one per string) (→ # 39)
- 2 STO status outputs (one per string) (→ # 39)
- Service Interface (→ # 82)
- EtherCAT Interface (→ # 81)

7.2 Mechanical Data

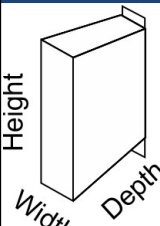
	Mechanical data	Units	AKD-C01007-x
	Weight	kg	3.8
	Height front	mm	290
	Height back	mm	329
	Width	mm	80
	Depth, without connectors	mm	198
	Depth, with connectors	mm	231

7.3 Electrical Data

Electrical data	Units	Value
Rated supply voltage (L1, L2, L3)	V~	3 x 400 V to 3 x 480 V, ±10%
Rated supply input frequency	Hz	40 Hz to 70 Hz
Rated input power		
at 3x400 V	kVA	9.2
at 3x480 V	kVA	11
Rated input current at 3x400/480 V	A	14
Permitted switch on/off frequency, mains	1/h	30
Max. inrush current	A	5
Rated DC bus link voltage (Bus Turn on Delay 3ph 1 sec)	V=	565 to 680
Standby DC power voltage	V=	55 ±10%
Continuous total output current	A=	17
Peak total output current (for 1 s, ± 3%)	A=	34
Continuous output power		
at 3x400 V	kVA	9.2
at 3x480 V	kVA	11
Peak output power (for 1 s)		
at 3x400 V	kVA	18.4
at 3x480 V	kVA	22
Technical data for regen circuit	—	(→ # 36)
Thermal dissipation at 24V standby		
No AKD-N (min)	W	8.6
16 AKD-N (max)	W	40
Thermal dissipation at rated current (without regen power)	W	125
Noise emission (low speed / high speed fan)	dB(A)	40 / 60
Aux. voltage supply (PELV)	V=	24 V (±10%, check voltage drop)
Aux. voltage supply current		
maximum required	A=	14
per AKD-N without brake	A=	0.33
Aux. voltage inrush current	A=	16
Protection class	-	IP20

7.4 Fusing

NOTE

Non renewable cartridge fuses must be used with finger safe fuse holders according to IEC 60529.

7.4.1 External power supply fusing

US cartridge fuses: Class CC or J, 600 VAC 200 kA, time-delay. The fuse must be UL and CSA listed, UL recognized is not sufficient.

EU cartridge fuses: types gS(gRL) or gG, 400 V/500 V, time-delay

Cartridge Fuses	Ampere rating	UL Region	CE Region
External AC power supply fusing	20A (Time-Delay)	example Eaton: LPJ20SP/DFJ20	example Siba: type gS/gG, D02, 20A
External 24 VDC supply fusing	15A (Time-Delay)	example Eaton: LPJ15SP/DFJ15	example Siba: type gS/gG, 15A

Cartridge fuse holders:

Example Eaton: CH Series Modular Fuse Holders, class J, 3 poles: CH30J3

Example Ferraz: Ultrasafe Fuse holders, class J, 3 poles: US3J3I

7.4.2 External regen resistor fusing

Cartridge Fuses	Ampere rating	UL Region	CE Region
AKD-C01007	25A	example Eaton: FWP-25A14F	example Siba: type aR, 25A

Cartridge fuse holders: example Eaton, CH Series, class J, 3 poles: CH14J3

7.5 Ambient Conditions, Ventilation, and Mounting Position

Storage	(→ # 18)
Transport	(→ # 18)
Surrounding air temperature in operation	0 to +40 °C under rated conditions +40 to +55 °C with continuous current derating 4 % per Kelvin
Humidity in operation	Relative humidity 5 to 85%, no condensation, class 3K3
Site altitude	Up to 1000 meters above mean sea level without restriction 1,000 to max. 2,000 meters above mean sea level with power derating 1.5%/100 m
Pollution level	Pollution level 2 as per IEC 60664-1
Vibrations	Class 3M1 according to IEC 60721-3-3
Environmental area	Cabinet IP 54 according to IEC 60529
Mounting position	Vertical
Ventilation	Built-in fan
NOTICE	The device shuts down in case of excessively high temperature in the control cabinet. Make sure sufficient forced ventilation is supplied within the control cabinet.

7.6 Grounding System

There are several ground networks in the device:

DCOM	common line for digital inputs on I/O connector X15
GND	24 V supply
STO-GND	STO input
0 V	internal digital ground, service channel

7.7 Signal Inputs/Outputs

Interface	Electrical Data
Enable input	<ul style="list-style-type: none"> ● as per IEC61131-2 type 1 ● ON: 15 VDC to 30 VDC, 2 mA to 15 mA ● OFF: -3 VDC to 5 VDC, < 1 mA ● update rate 250 μs ● galvanic isolation for 250 VDC
Digital output	<ul style="list-style-type: none"> ● as per IEC61131-2 type 1 ● max. 30 VDC, 100 mA ● short circuit proof ● galvanic isolation for 250 VDC
Relay output	<ul style="list-style-type: none"> ● max. 30 VDC, 1 A ● max. 42 VAC, 1 A ● time open/close 10ms ● isolation 400 VDC contact/coil
STO-Enable inputs	<ul style="list-style-type: none"> ● ON: 18 VDC to 30 VDC, AKD-C with one AKD-N 80 mA, every additional AKD-N + 25 mA ● OFF: 0 VDC to 12 VDC, < 50 mA ● galvanic isolation for 250 VDC
STO-Status outputs	<ul style="list-style-type: none"> ● as per IEC61131-2 type 1 ● max. 30 VDC, 100 mA ● galvanic isolation for 250 VDC

7.8 Connectors

Connector	Type	Max. Cross Section ¹	Current ²	Voltage ³
Motion Bus X10, X11	RJ45	0,5 mm ² , 21 awg	1 A	<100 V
Power X12	Terminal Connector, 4 poles	10 mm ² , 8 awg	30 A	1000 V
Aux. voltage X13	Terminal Connector, 2 poles	2.5 mm ² , 12 awg	16 A	250 V
DC bus, Regen X14	Terminal Connector, 4 poles	10 mm ² , 8 awg	30 A	1000 V
Control signals X15	Terminal Connector, 6 poles	1 mm ² , 18 awg	12 A	250 V
STO signals X16	Terminal Connector, 6 poles	1 mm ² , 18 awg	12 A	250 V
Service Port X18	RJ45	0,5 mm ² , 21 awg	1 A	<100 V
DC Power X20A, X21A	Terminal Connector, 3 poles	10 mm ² , 8 awg	30 A	1000 V
Local Fieldbus In/Out X20B, X21B	Mini I/O connector, 8 poles	0.34 mm ² , 22 awg	0.5 A	30 V

¹single-line connection

²single-line connection with recommended conductor cross section (→ # 33)

³rated voltage with pollution level 2 (lowest values allowed by UL840 and IEC60664)

7.9 Recommended Tightening Torques

Connector	Tightening Torque/Nm
X13, X15, X16	0.2 to 0.25
X12, X14, X20A, X21A	0.7 to 0.8
PE bolt	1.7

See (→ # 23) for in-lbs values.

7.10 Cable Requirements

The table below describes the recommended interface cross sections and cable requirements in accordance with IEC 60204. For information on the chemical, mechanical, and electrical characteristics of the cables please refer to the accessories manual or contact customer support.

NOTE

Use Kollmorgen hybrid, motor, and feedback cables only. You will lose system warranty, if you use hybrid, motor or feedback cables from a manufacturer other than Kollmorgen.

Hybrid cable from	Cable type*	Hybrid cable to	Cross section
AKD-C X20A/X20B String 1	CCNCN1-025	AKD-N X1, hybrid	3 x 2.5 mm ² 4 x 0.25 mm ²
AKD-C X21A/X21B String 2	CCNCN1-025	AKD-N X1, hybrid	3 x 2.5 mm ² 4 x 0.25 mm ²

* Followed by length coding. Contact your Kollmorgen sales representative.

Interface	Cross Section	Cable Requirements
X12, AC connection	4.0 mm ² (12 awg)	600 V, minimum 75°C

Interface	Cross Section	Cable Requirements
X13, +24 V/GND	2.5 mm ² (14 awg)	single line
X14, DC bus link, regen resistor	4.0 mm ² (12 awg)	1000 V, minimum 75°C, shielded for lengths >0.20 m
X15, Digital I/Os	0.5 mm ² (21 awg)	single line
X16, STO Signals	0.5 mm ² (21 awg)	single line

7.11 Cable Length Definition

NOTE AKD-C offers two separate strings to connect up to 8 AKD-N to each of them. Maximum total cable length for each string is 100 m. For system topology information refer to (→ # 60)

Cable Type	Cable usage	Available Length (m)	Max. Length (m)
CCNCN1	X20/X21, AKD-C to AKD-N, hybrid	3, 6, 12, 24, 36	40
Ethernet Cable	X10/X11, AKD-C to AKD-C	on request	100
Ethernet Cable	X10/X11, AKD-C to Personal Computer or Switch	on request	100
single line	X13 +24 V/GND, X15 Digital I/Os, X16 STO Signals		30

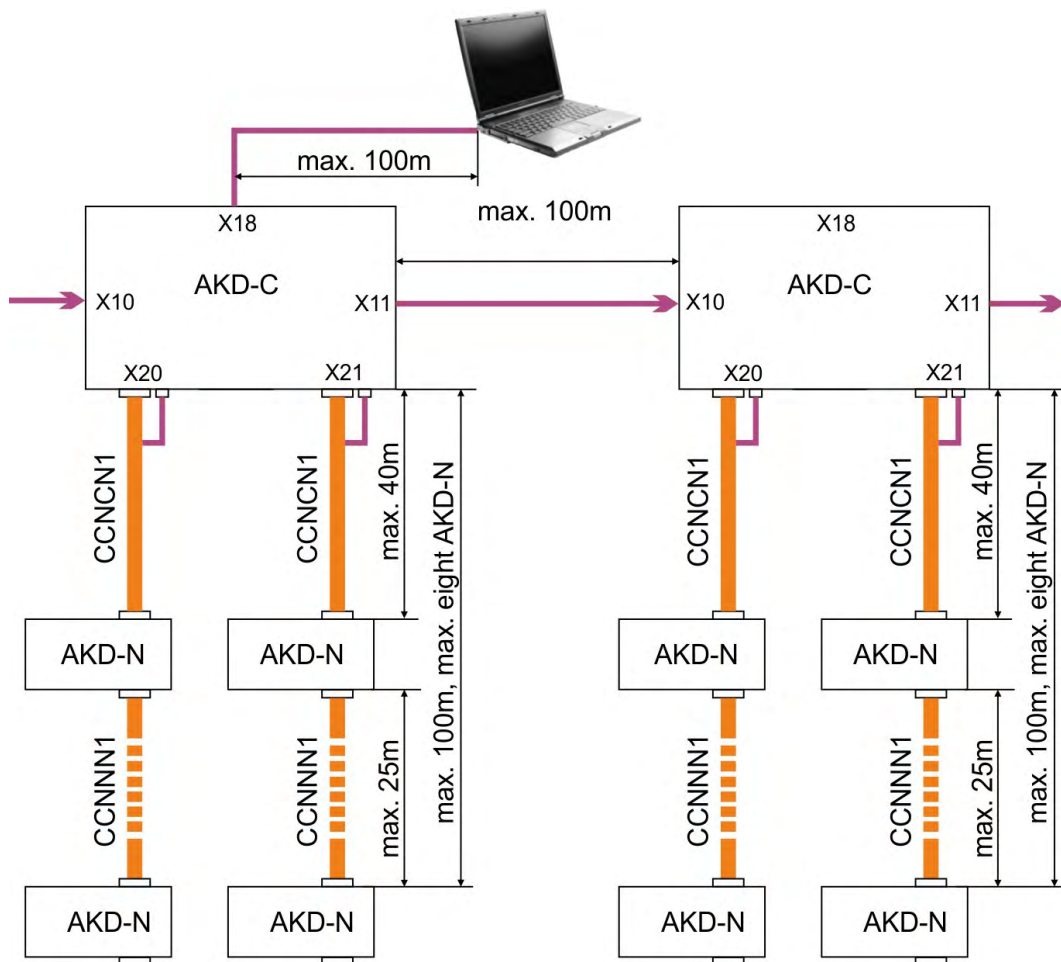

7.12 Dynamic Braking

Dynamic braking is a method to slow down a servo system by dissipating the mechanical energy driven by the motor back EMF. The AKD-N drives have a built in advanced dynamic braking mode which operates fully in hardware. When activated, the drive shorts the motor terminals in phase with the back EMF (q axis) but continues to operate the non-force producing current loop (d-axis) with 0 current. This forces all of the dynamic braking current to be stopping current and insures the fastest stopping/amp of motor terminal current.

- When current is not being limited, the mechanical energy is being dissipated in the motor resistance.
- When current is being limited, energy is returned to the AKD-C bus capacitors.
- The drive also limits the maximum dynamic braking motor terminal current via the *DRV.DBILIMIT* parameter to insure that the drive, motor, and customer load do not see excessive currents/forces.

Whether and how the AKD uses dynamic braking depends on (*DRV.DISMODE*).

7.13 Regen circuit

When the amount of returned energy from the AKD-N builds the bus capacitor voltage up enough, the AKD-C activates the regen circuit to start dumping the returned energy in the regen resistor (also called regenerative or brake resistor). The AKD-C has an internal regen resistor, an additional external one can be connected to X14.

External regen resistors are described in the regional *Accessories Manual*.

7.13.1 Functional description

When the amount of returned energy builds the bus capacitor voltage up enough, the AKD-C activates the brake chopper to start dumping the returned energy in the regen resistor at the AKD-C (internally or connected to terminal X14). 90% of the combined power of all the coupled drives is always available for peak and continuous power.

The drive that has the lowest switch-off threshold (resulting from tolerances) reports an over-voltage fault if the DC bus threshold is exceeded. The drive power stage is disabled and the load coasts to a stop with the fault message "F501 Bus Over voltage" (→ # 91). The AKD-C fault relay contact (terminals X15/5-6) is opened due to this fault.

7.13.2 Technical data

NOTE

Observe the regeneration time (some minutes) after full load with peak regen power.

Rated data	Units	400 V	480 V
Switch-on threshold of regen circuit (nominal)	V	760	760
Overtoltage limit	V	840	840
Maximum regen duty cycle	%	15*	15*
Internal regen resistor	Ohm	33	33
Continuous power, internal resistor	W	100	100
Peak regen power, internal resistor (0.5s)	kW	17.5	17.5
External regen resistor	Ohm	33	33
Maximum continuous regen power, external resistor	kW	1.5	1.5
Peak regen power, external (1s)	kW	17.5	17.5
Absorption energy in capacitors (+/- 20%)	Ws	21	7
DC Bus Capacitance (nominal)	µF	585	585

* depends on connected regen resistor power

7.14 Switch-On and Switch-Off Behavior

7.14.1 Switch-on behavior in standard operation

The diagram below illustrates the correct functional sequence for switching the System on.

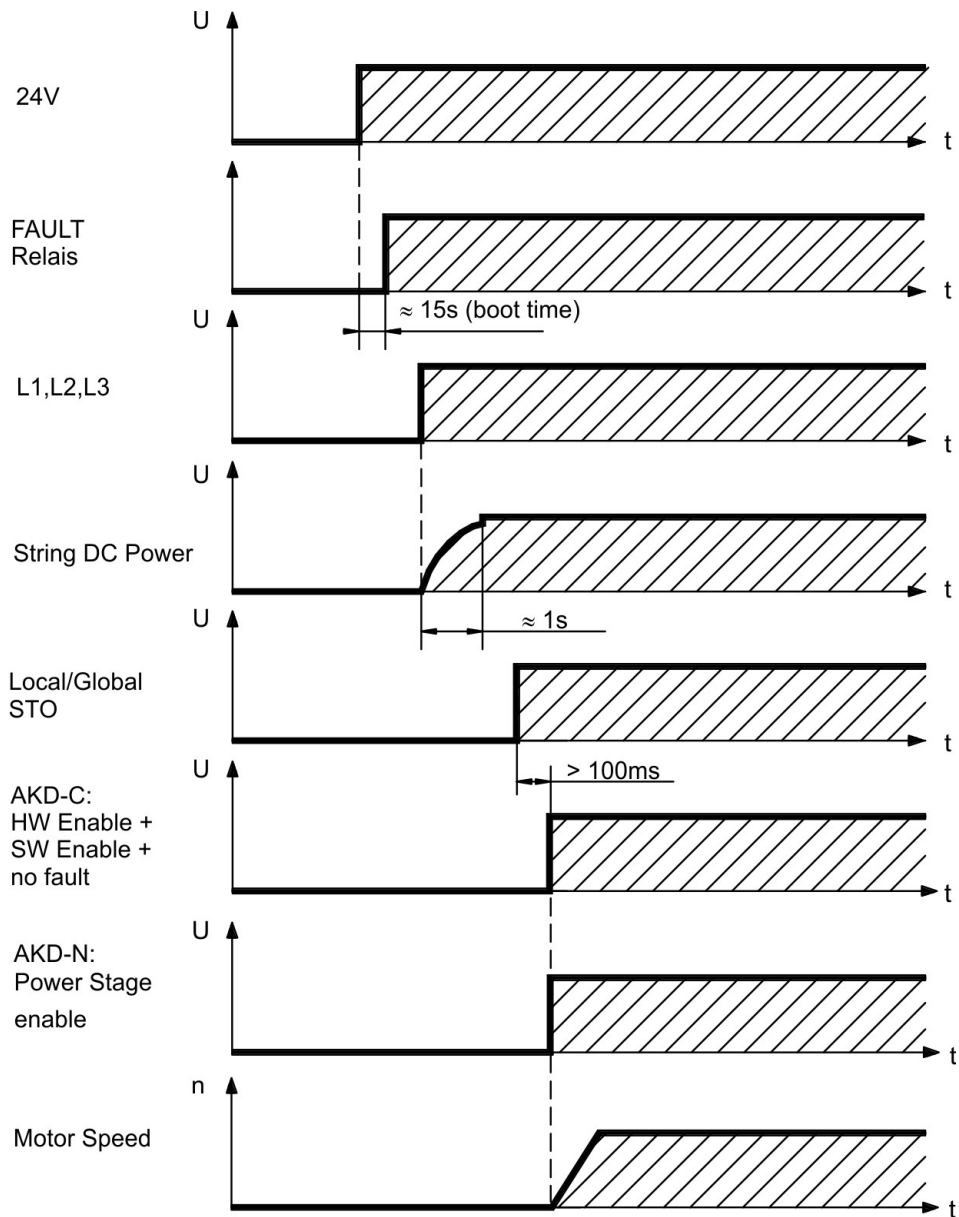

7.14.2 Switch-off process, standard operation

NOTE

Hardware Enable input disables all AKD-N power stages immediately. Refer to the *AKD-N Installation Manual* for drive switch-off behaviour depending on different operational situations and parameter settings.

The control functions Stop, Emergency Stop and Emergency Off are defined by IEC 60204. Notes for safety aspects of these functions can be found in ISO 13849 and IEC 62061.

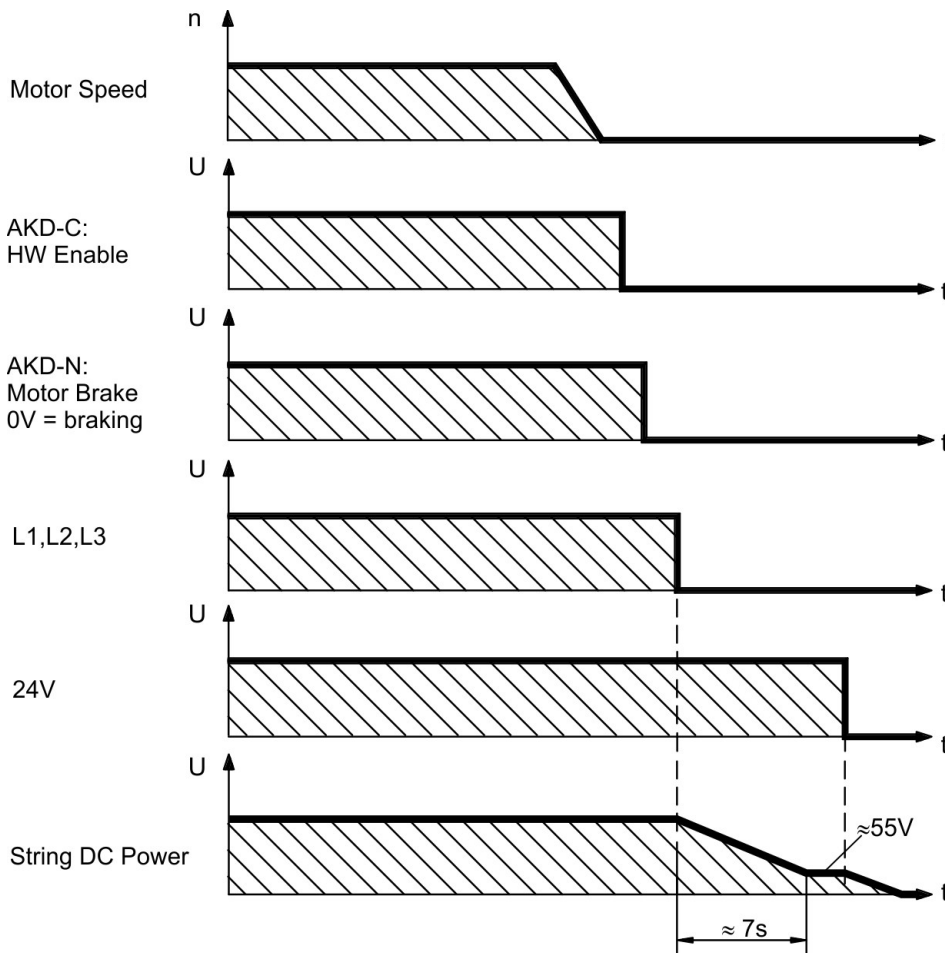

7.15 Global Safe Torque Off (STO)

7.15.1 STO Safety instructions



WARNING No Brake Power!

Serious injury could result when a suspended load is not properly blocked. The drive cannot hold a vertical load when STO is active.

- Add a safe mechanical blocking (for instance, a motor-holding brake).
- The drives have not to be used for driving elevators.



WARNING Automatic Restart!

Risk of death or serious injury for humans working in the machine. The drive might restart automatically after power on, voltage dip or interruption of the supply voltage, depending on the parameter setting. If parameter DRV.ENDEFAULT for one AKD-N is set to 1,

- then place a warning sign ("WARNING: Possible Automatic Restart" or similar) to the machine.
- Ensure, that power on is not possible, while humans are in a dangerous zone of the machine.
- In case of using an undervoltage protection device, you must observe EN 60204-1:2006 chapter 7.5 .



CAUTION High electrical voltage!

Risk of electrical shock! The STO function does not provide an electrical separation from the power output. If access to the motor power terminals is necessary,

- disconnect the drive from mains supply,
- consider the discharging time of the DC-Bus link.

NOTICE

If the safety function STO is automatically activated by a control system, then make sure that the output of the control is monitored for possible malfunction. The monitoring can be used to prevent a faulty output from unintentionally activating the STO function.

NOTICE

It is not possible to perform a controlled brake if the drive controlled STO-Enable is off. If controlled braking before the use of the STO function is necessary, the drive must be braked and the input STO must be separated time-delayed from +24 V .

NOTICE

In case of a specific double fault within a very short time (see (→ # 40) a single movement of a maximum angle of 120° (electrical) can happen. This effect can only happen if the drive is in the function STO. Even if the STO function will be issued for a whole year, this event will only happen every 100 Billion years.

NOTE

The STO Status signals are informal and not relevant for functional safety.

7.15.2 Use as directed

The STO function is exclusively intended to provide a functional safe torque off of the motion system. To achieve this functional safety, the wiring of the safety circuits must meet the safety requirements of IEC 60204, ISO 12100 and ISO 13849.

If the global STO function is in use, then the inputs STO-Enable 1/2 must be connected to the exit of a safety control or a safety relay, which at least meets the requirements of PLd, CAT 3 according to ISO 13849.

The 24 VDC supply unit for local STO supply must accord to PELV (EN 60204-1) requirements.

7.15.3 Prohibited use

The STO function must not be used if the drive is to be made inactive for the following reasons:

- Cleaning, maintenance and repair operations, long inoperative periods. In such cases, the entire system should be disconnected from the supply and secured (main switch).
- Emergency-Off situations. In an Emergency-Off situation, the main contactor is switched off (by the Emergency-Off button).
- Wiring the system with hybrid cables from other manufacturers than Kollmorgen is not allowed.
- Changing cables or connectors is not allowed.
- Do not use STO Status signals for functional safety.

7.15.4 Safety characteristic data

The systems are described with the following characteristic data:

Structure	STO	ISO 13849-1	MTTF _d	IEC 62061	PFH [1/h]	SFF [%]	T _M [Years]
AKD-C + 1 x AKD-N	global	PL d, CAT 3	≥ 100	SIL 2	2.99E-08	97.08	20
AKD-C + 8 x AKD-N	global	PL d, CAT 3	≥ 100	SIL 2	3.07E-08	99.44	20
1 x AKD-N-DS/DT	local	PL d, CAT 3	≥ 100	SIL 2	2.9E-08	97.12	20

NOTICE

A very unlikely but possible event can happen, if within a very short time 2 not adjacent IGBTs will have a short circuit. In such case a movement of a maximum angle of 120° (electrical) can happen. This effect can only happen if the drive is in the function STO. If the total failure rate of the IGBT is 120 FIT normally for such short circuit 60 FIT will be valid (50:50 model). By such event 2 specific IGBTs have to fail at same time. The calculation shows a probability of $1.5 \cdot 10^{-15}$ per hour (without common cause failure). Even if the STO function will be issued for a whole year, this event will only happen every 100 Billion years.

7.15.5 Response Time

The delay from falling edge at global STO Enable input until energy supply to the motor is interrupted, depends on the number of connected AKD-N to the string. Maximum reaction time is 10 ms. The more AKD-N are connected to the string, the shorter is the reaction time.

7.15.6 General information

Connector X16 offers access to all STO (Safe Torque Off) relevant signals of the decentral drive system powered by this AKD-C .

NOTE The global STO function uses the following devices: AKD-C, AKD-N without option "DS" or "DT", Kollmorgen hybrid connection cable.

There is one STO-Enable input and one STO-Status output for each DC Power string. STO-Enable 1 does affect string 1 only. STO-Enable 2 does affect string 2 only.

The string STO input releases the power output stage of all AKD-N (without option DS/DT) connected to the string as long as a 24 V signal is applied to this input. If the STO input goes open-circuit, then power will no longer be supplied to the connected motors, and the drives will lose all torque and coast to a stop.

NOTE In case of using an AKD-N with option "DS" or "DT" (local STO input), the global STO signal will have not influence to this specific drive. The local STO input on the AKD-N has no influence to the global STO as well. The local STO functionality is described in the AKD-N installation manual.

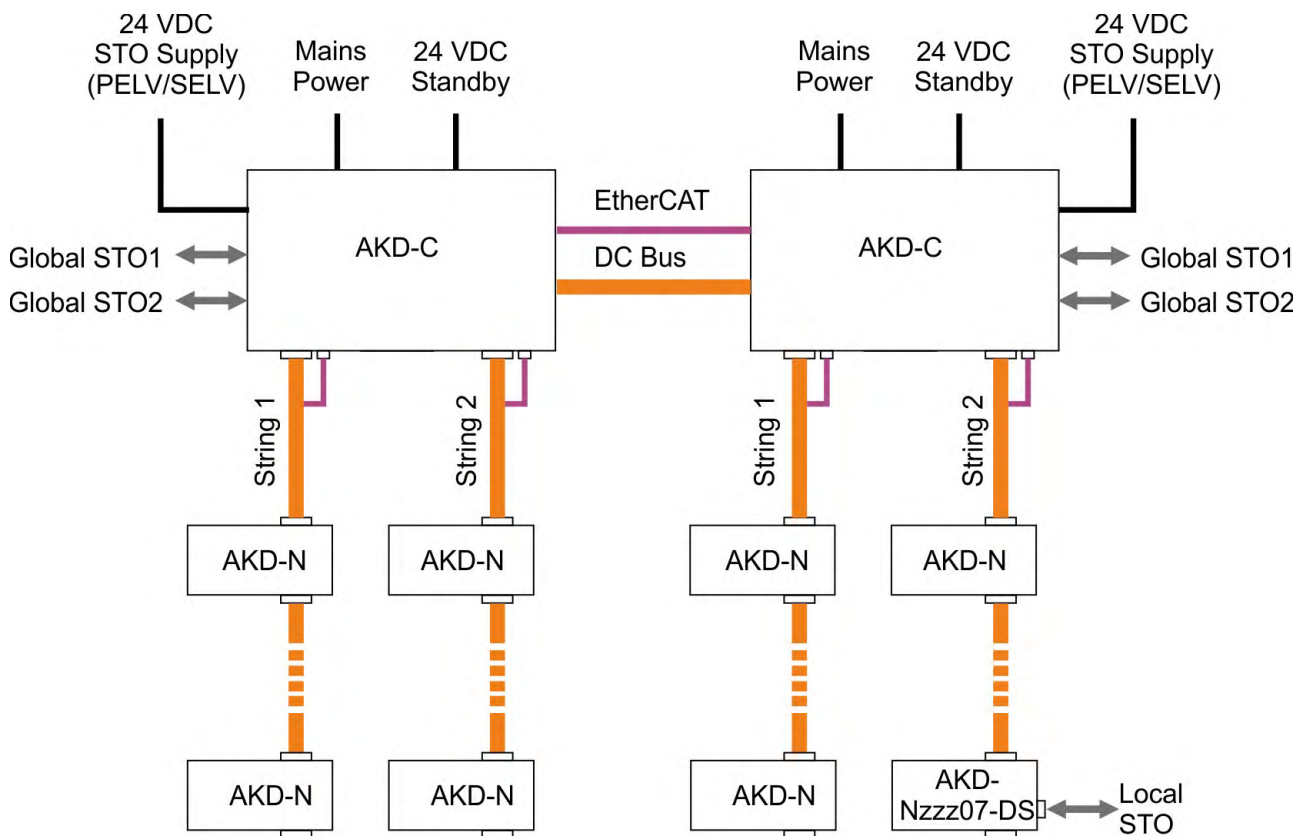

The STO safety implementation on the AKD is certified. The safety circuit implementation used for the safety function "Safe Torque Off" in the drive is suited for SIL 2 according to IEC 62061 and PLd / CAT3 according to ISO 13849-1.

Application examples can be found in the *Decentralized System Project Guide*.

7.15.7 Enclosure, wiring

Wiring examples (→ # 46). Observe the required ambient conditions as described in chapter (→ # 31).

The AKD-C (IP 20) must be mounted in an IP54 cabinet to ensure pollution level 2 according to IEC 60664-1. Connector X16 (STO signals) ensures requirements of pollution level 3 according to IEC 60664-1.

The AKD-N can be used in an environment that requires IP67 devices.

Wiring inside the cabinet

Wiring remaining must meet the requirements of the standard IEC 60204-1. In compliance with the safety standard ISO 13849-2 Table D.4; short-circuits between conductors or of any conductor to an exposed conductive part can be excluded when:

- permanently connected (fixed) and protected against external damage, e. g. by cable ducting, armouring, or
- within separate multicore cables, or
- within the IP54 electrical enclosure, or
- individually shielded with earth connection.

This is valid also for the STO wiring of AKD-C.

Wiring outside the cabinet

If you are wiring leads that are outside the specified enclosure (IP54), the cables must be laid durably (firmly), protected from outside damage (for example, by laying the cable in a duct), placed in different sheathed cables, or protected individually by grounding connection.

Maximum cable length

Maximum cable length for safety relevant I/Os and for the 24 V supply is 30 m.

7.15.8 Technical data and connection

NOTE The global STO inputs are not compatible with IEC 61131-2. Connector X16 (STO signals) ensures requirements of pollution level 3 according to IEC 60664-1.

STO-Enable inputs	<ul style="list-style-type: none"> inputs do not match IEC61131-2 galvanic isolation for 250 VDC OFF: 0 VDC to 12 VDC, < 50 mA ON: 18 VDC to 30 VDC, AKD-C with one AKD-N 80 mA, every additional AKD-N + 25 mA tolerated OSSD pulse duration 300 μs
STO-Status outputs	<ul style="list-style-type: none"> as per IEC61131-2 type 1 max. 30 VDC, 100 mA galvanic isolation for 250 VDC
STO 24 VDC supply	<ul style="list-style-type: none"> PELV acc. to EN 60204-1 Output 24 VDC +/-10% Current 5 A (full system STO supply)

Pinout connector X16 STO Signals

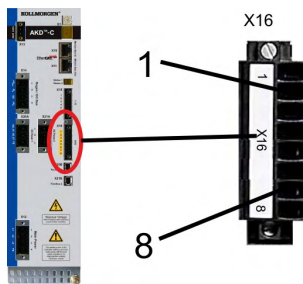

Pin	Signal	Description
1	STO-Status 1	STO-Status message string 1
2	STO-Status 2	STO-Status message string 2
3	+24	STO +24 VDC supply
4, 5	GND	STO GND
6	STO-Enable 1	STO Enable string 1
7	GND	STO GND
8	STO-Enable 2	STO Enable string 2

Wiring diagram STO Signals

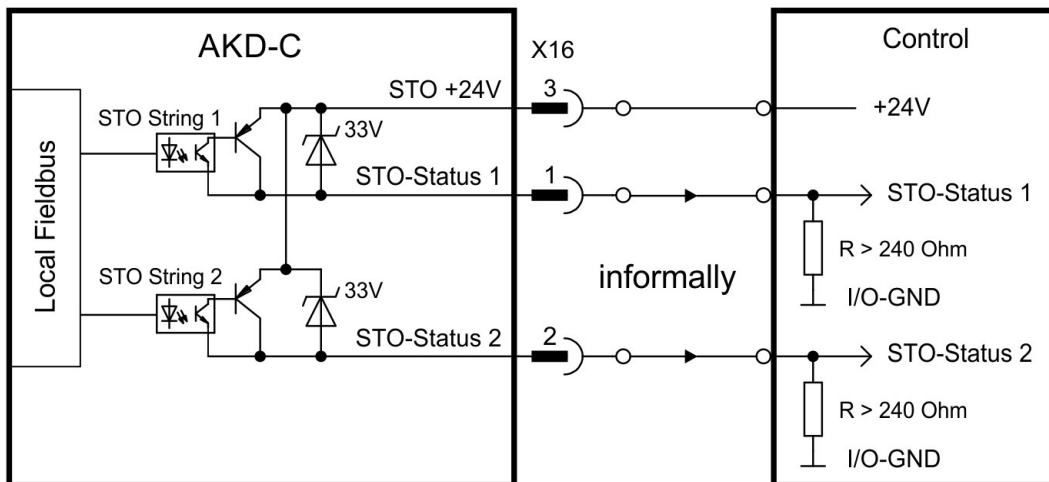
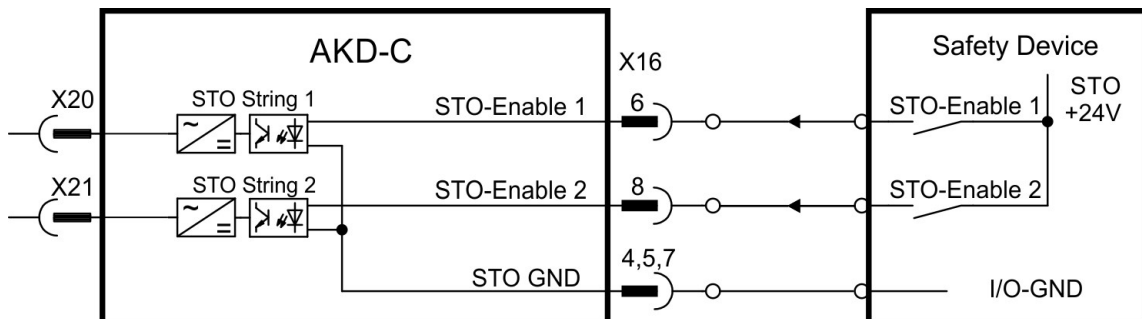

7.15.9 Functional description

There is one STO-Enable input and one STO-Status output for each string. The string STO-Enable input releases the power output stage of all AKD-N (without option "DS" or "DT") connected to the string as long as a 24 VDC signal is applied to this input. When STO function is engaged during operation by separating STO-Enable from 24 V, the drives (without option DS/DT) connected to the string slow down without control.

When the global STO function (Safe Torque Off) is not needed, then the inputs STO-Enable 1/2 must be connected directly to +24 VDC. The function is then bypassed and cannot be used in the machinery safety concept.

NOTE

In case of using an AKD-N with option "DS" or "DT" (local STO input) in the string, then the string STO-Enable signal will have no influence to this specific drive. The local STO-Status of this drive nevertheless is monitored in the string STO-Status.

NOTE

The string STO-Status output at the AKD-C is a logical OR of all STO-Status of the drives connected to that respective string. STO-Status is high:

- during system boot (power up), or
- if the string STO-Enable input is 0V, or
- if the communication with one of the connected drives is lost, or
- if no drive is connected to the string, or
- if the local fieldbus doesn't work.

Possible states of the drives connected to the string referring to the global STO function:

String STO-Enable	String HW Enable	String STO-Status	Safety acc. to SIL2	AKD-N on String can produce Torque
0 V	no	high	yes	no
0 V	yes	high	yes	no
+24 V	no	low	no	no
+24 V	yes	low	no	yes

NOTICE

Use the following functional sequence when the STO function is used:

1. Brake the drives in a controlled manner (speed setpoint = 0 V).
2. When drives speed = 0 rpm, disable the string (enable = 0 V).
3. If a suspended load is present, block the drive mechanically.
4. Activate the STO function.

NOTE

It is not possible to perform a controlled brake if the STO-Enable is off. If controlled braking prior to the use of the STO function is necessary, the drive must be braked first and the input STO must be separated from +24 V time-delayed.

NOTE

When wiring the input STO within one enclosure, the cables and the enclosure must meet the requirements of IEC 60204-1. If you are wiring leads outside the specified enclosure, then the cables must be laid durably and protected from outside damage.

7.15.9.1 Signal diagram (sequence)

The diagram below shows how to use global STO function for a safe drive stop and fault free operation of the drives connected to one of the strings.

1. Brake the drives in a controlled manner (speed setpoint = 0 V).
2. When speed = 0 rpm, disable the drives (Enable = 0 V).
3. Activate the STO function (STO_Enable = 0 V)
4. For restart you must reset the safety device.

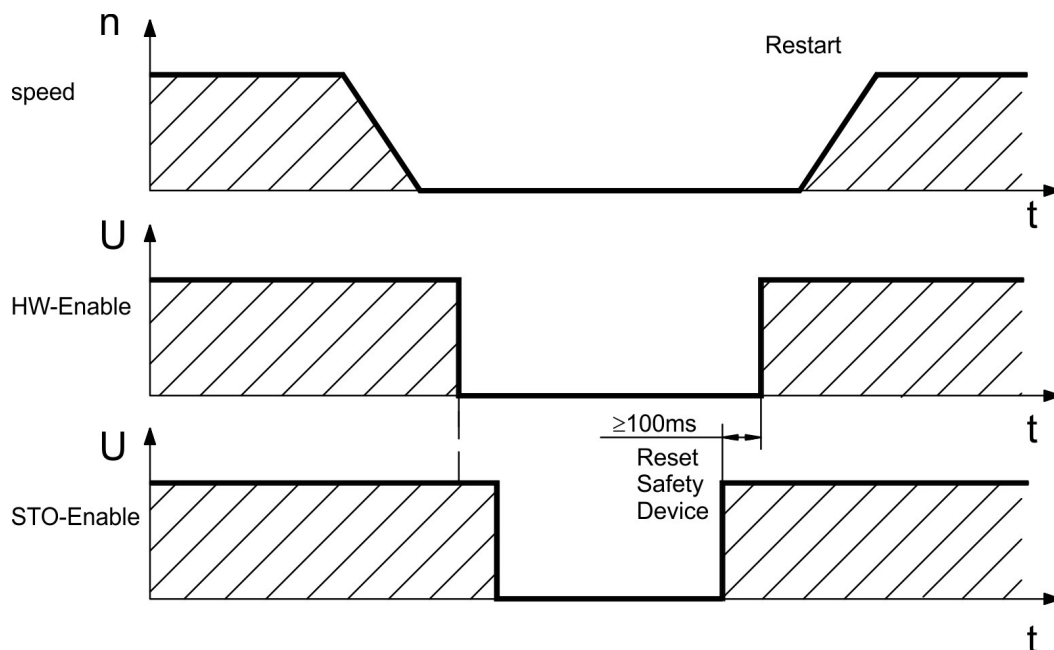

7.15.9.2 Functional test

NOTICE

You must test the safe torque off function after initial start of the drive, after each interference into the wiring of the drive, or after exchange of one or several components of the drive.

First Method:

1. Stop drives in the string with setpoint 0 V. Keep drives enabled.
DANGER: Do not enter hazardous area!
2. Activate the global STO function for example by opening protective screen of the string, where the drives are connected (voltage at AKD-C X16/6 or X16/8 0V).
3. The AKD-C fault contact opens, the corresponding string STO-Status message (X16/1 or X16/2) changes the voltage level, the drives lose torque and slow down to zero speed without control.

Second Method:

1. Stop all drives in the string with setpoint 0 V, disable the string.
2. Activate the global STO function, for example, by opening protective screen (voltage at AKD-C X16/6 or X16/8 0V)
3. The corresponding string STO-Status message (X16/1 or X16/2) changes the voltage level, the string cannot be enabled.

7.15.9.3 Global STO application example with Safety Control

The sample application below shows door guarding and emergency stop, controlled by a safety control to switch the global STO-Enable inputs of an AKD-C device to SIL2, PLd. Both drive strings are switched independently.

NOTE Kollmorgen KSM modules cannot be used.

For detailed application examples refer to the *Decentralized System Project Guide*.

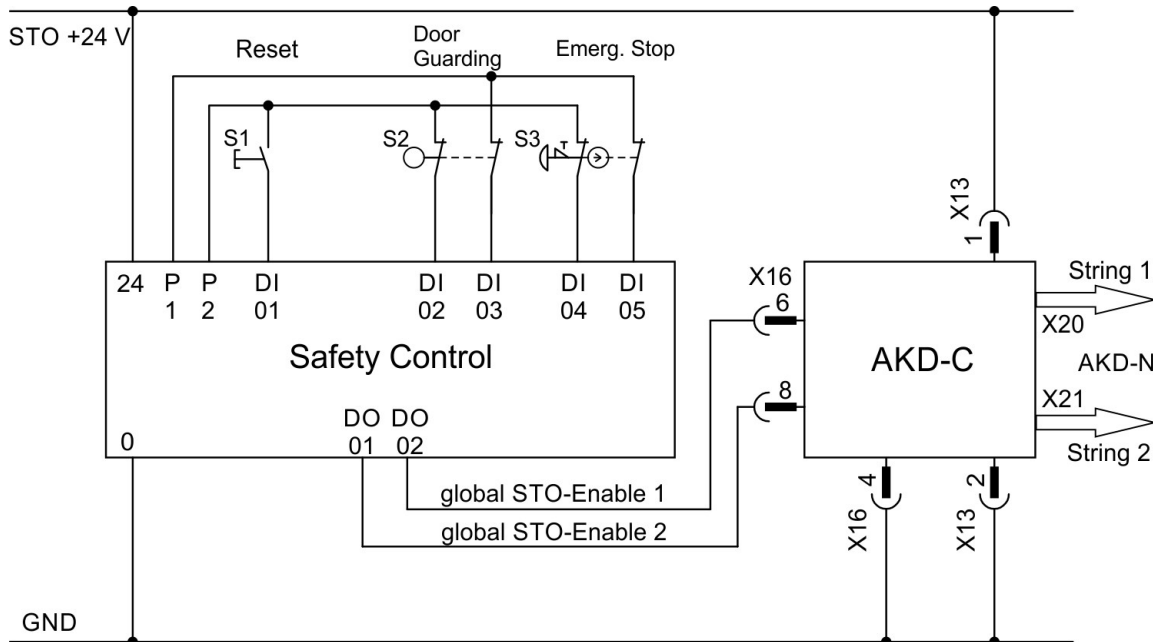

7.15.9.4 OSSD test pulses

Safety controllers usually check their outputs periodically during the normal operation. These test procedures create pulses to the STO-Enable inputs.

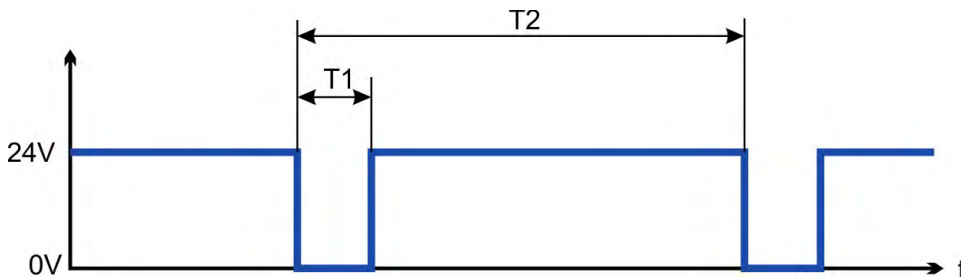

Test pulses with $T1 < 300 \mu s$ and $T2 > 200 ms$ will not have any influence to the safety relevant STO function. Test pulses, which are outside of this specification, will switch the STO function, but will not create a dangerous situation.

7.16 Shock-hazard Protection

7.16.1 Leakage current

Leakage current via the PE conductor results from the combination of equipment and cable leakage currents. The leakage current frequency pattern includes a number of frequencies, whereby the residual-current circuit breakers definitively evaluate the 50 Hz current. For this reason, the leakage current cannot be measured using a conventional multimeter.

NOTE

Since the leakage current to PE is more than 3.5 mA, in compliance with IEC61800-5-1 the PE connection must either be doubled or a connecting cable with a cross-section >10 mm² must be used. Deviating measures according to regional standards might be possible

7.16.2 Residual current protective device (RCD)

NOTE

AKD-C with connected AKD-N can cause a d.c. current in the protective earthing conductor. Where a residual current-operated protective (RCD) or monitoring (RCM) device is used for protection in case of direct or indirect contact, only an RCD or RCM of Type B is allowed on the supply side of AKD-C.

In conformity with IEC 60364-4-41 – Regulations for installation and IEC 60204 – Electrical equipment of machinery, residual current protective devices (RCDs) can be used provided the requisite regulations are complied with.

The AKD-C is a 3-phase system with a B6 bridge. Therefore, RCDs which are sensitive to all currents must be used in order to detect any DC fault current.

Rated residual currents in the RCDs:

10 to 30 mA	Protection against "indirect contact" (personal fire protection) for stationary and mobile equipment, as well as for "direct contact".
50 to 300 mA	Protection against "indirect contact" (personal fire protection) for stationary equipment

If you use a selective RCD, the more intelligent evaluation process will prevent spurious tripping of the RCD.

7.16.3 Isolating transformers

When protection against indirect contact is absolutely essential despite a higher leakage current, or when an alternative form of shock-hazard protection is sought, the AKD can also be operated via an isolating transformer (schematic connection (→ # 65). A ground-leakage monitor can be used to monitor for short circuits.

NOTE

Keep the length of wiring between the transformer and the drive as short as possible.

7.17 LED Display

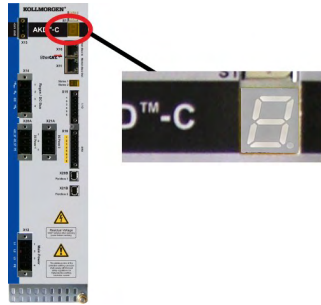

The LED seven-segment display indicates the status of the drive after the 24 V supply is switched on. If the service connection to the PC or to the PAC doesn't work, then the LED display is the only way to get information. AKD fault codes or warning codes are displayed constantly if present. Fault messages are coded with "F" or "E", warnings are coded with "n". The IP address can be flashed across the LED display if the B1 button is pressed.

The local fieldbus status LEDs are described in (→ # 76).

8 Mechanical Installation

8.1 Important Notes	50
8.2 Dimension Drawing	51
8.3 Mounting Example	52

8.1 Important Notes



CAUTION High EMC Voltage Level!

Risk of electrical shock, if the servo amplifier (or the motor) is not properly EMC-grounded.

- Do not use painted (i.e. non-conductive) mounting plates.
- In unfavourable circumstances, use copper mesh tape between the earthing bolts and earth potential to deflect currents.

NOTICE

Protect the device from impermissible stresses. In particular, do not let any components become bent or any insulation distances altered during transport and handling. Avoid contact with electronic components and contacts.

NOTICE

The device will switch itself off in case of overheating. Ensure that the mounting space matches the requirements (→ # 31).

NOTICE

Do not mount devices that produce magnetic fields directly beside the device. Strong magnetic fields can directly affect internal components. Install devices which produce magnetic field with distance to the AKD-C and/or shield the magnetic fields.

8.2 Dimension Drawing

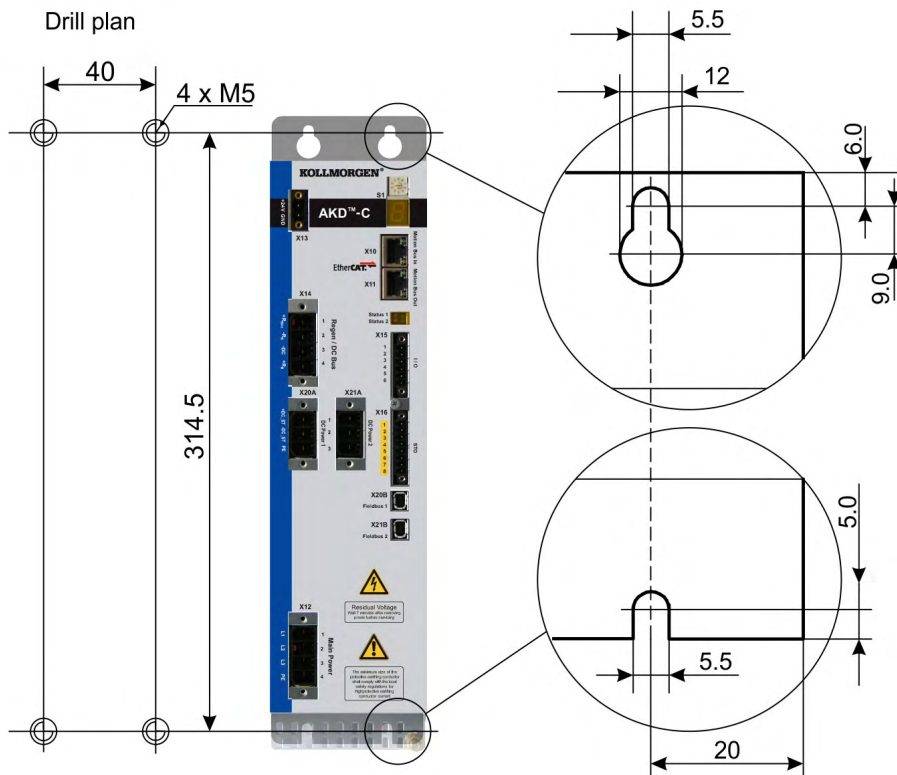
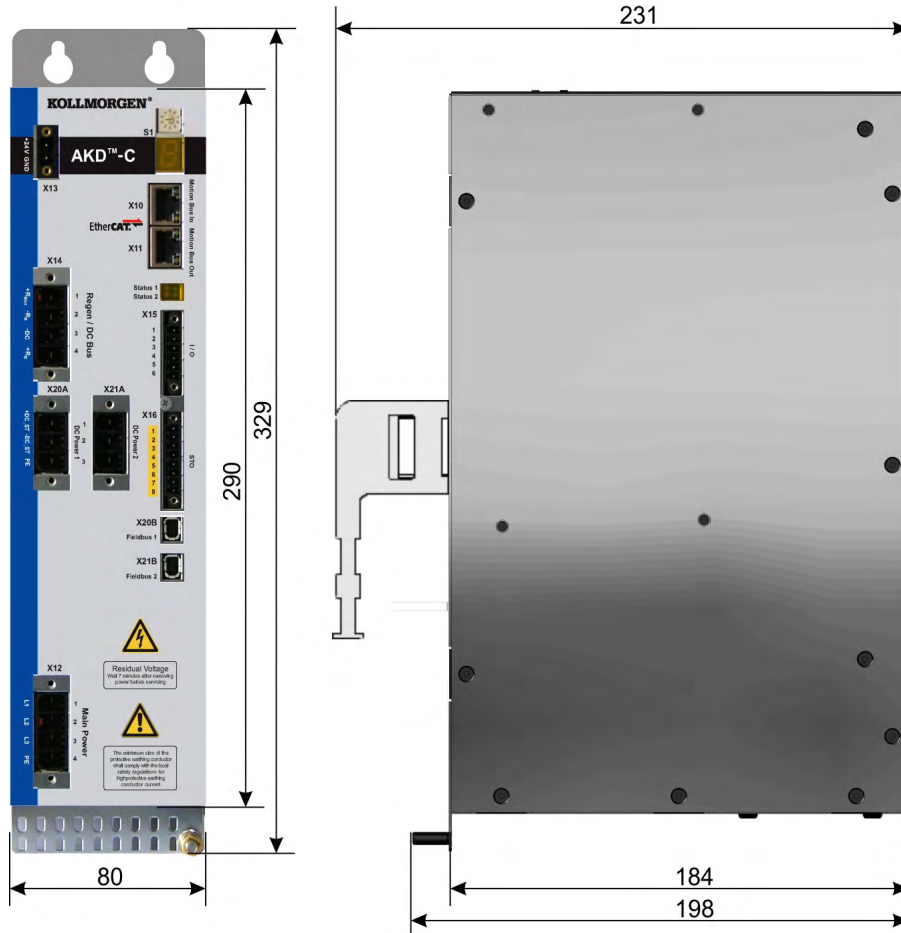

8.3 Mounting Example

Mounting material: Four M5 hexagon socket screws to ISO 4762, 4 mm T-handle Allen key.

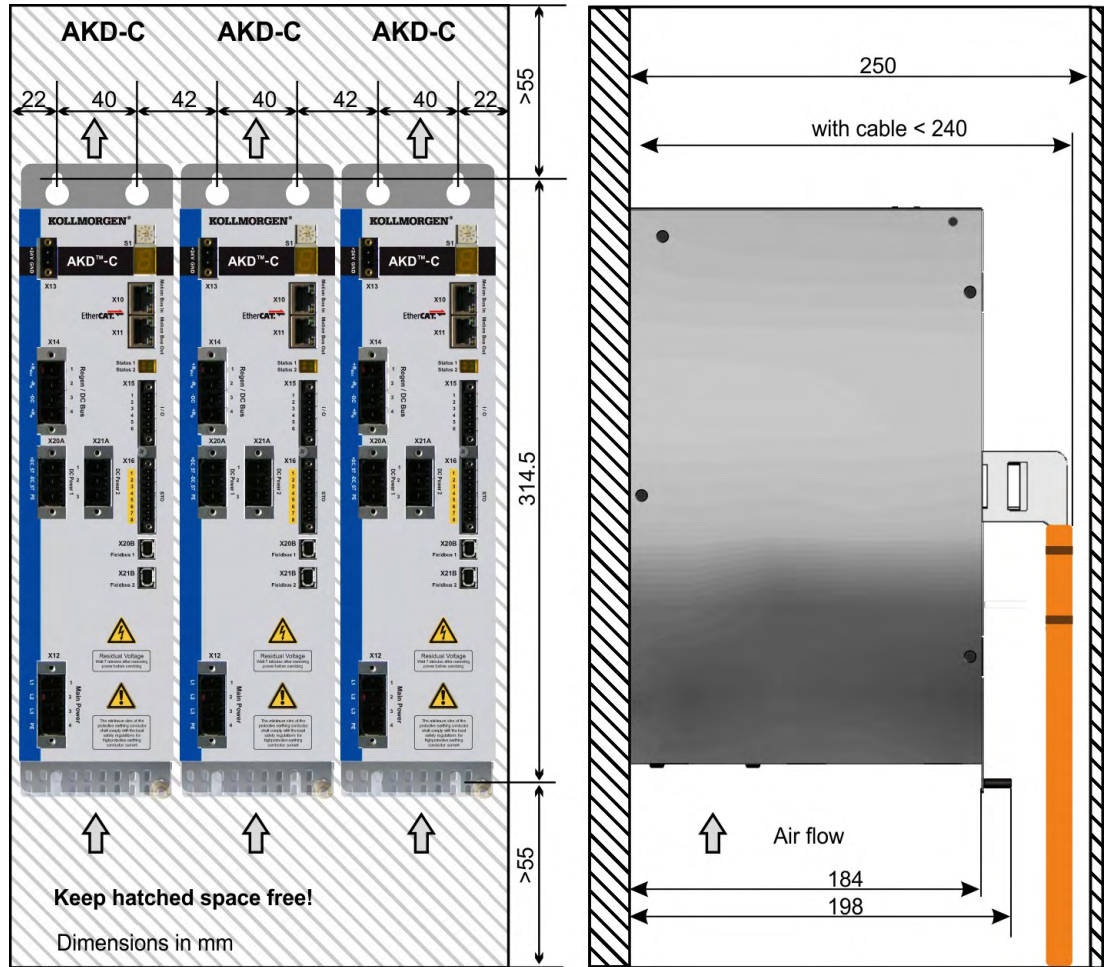

9 Electrical Installation

9.1 Important Notes	54
9.2 Guide to Electrical Installation	55
9.3 EMI Noise Reduction	56
9.4 System Topology of a Decentralized Servo System	60
9.5 Wiring	62
9.6 Connection Overview	63
9.7 Electrical Supply Connection	65
9.8 DC Bus link (X14)	68
9.9 Drive String Connection	74
9.10 I/O Connection	77
9.11 Motion Bus Interface (X10/X11)	81
9.12 Service Interface (X18)	82
9.13 Push-button (B1)	83
9.14 Rotary Switches (S1), Setting IP address	83

9.1 Important Notes

NOTICE

Only professional staff who are qualified in electrical engineering are allowed to install the drive. Wires with color green with one or more yellow stripes must not be used other than for protective earth (PE) wiring.



⚠ DANGER High Voltage up to 900 V!

There is a danger of serious personal injury or death by electrical shock or electrical arcing. Capacitors can still have dangerous voltages present up to 7 minutes after switching off the supply power. Control and power connections can still be live, even if the motor is not rotating.

- Only install and wire the equipment when it is not live.
- Make sure that the cabinet is safely disconnected (for instance, with a lock-out and warning signs).
- Never remove electrical connections to the drive while it is live.
- Wait at least 7 minutes after disconnecting the drive from the main supply power before touching potentially live sections of the equipment (e.g. contacts) or undoing any connections.
- To be sure, measure the voltage in the DC bus link and wait until it has fallen below 50 V.

NOTICE

Since the leakage current to PE is more than 3.5 mA, in compliance with IEC61800-5-1 the PE connection must either be doubled or a connecting cable with a cross-section >10 mm² must be used. Deviating measures according to regional standards might be possible.

NOTICE

Wrong DC Bus link voltage, unsuitable motor or wrong wiring will damage the system components. Check the combination of drive and motor. Compare the rated voltage and current of the units. Implement the wiring according to the connection diagrams: (→ # 63).

NOTE

It is permissible to use the setup software to alter the settings of the device. Any other alterations will invalidate the warranty.

9.2 Guide to Electrical Installation

Install the electrical system as follows:

1. Select cables in accordance with IEC 60204 (→ # 33.) and the system topology (→ # 60).
2. Install shielding and ground the AKD-C.
Ground the mounting plate and CNC-GND of the control system.
3. Wire the device.
 - Wire the FAULT contact in series into the emergency off circuit of the system.
 - If required, connect the external regen resistor (with fusing).
 - Connect the required AKD-N drives to string 1 or string 2.
 - Connect the Enable input and the digital output, if required.
 - Connect the STO inputs and STO status outputs for the used strings (→ # 39).
 - Connect the auxiliary supply (maximum permissible voltage values see electrical data (→ # 30).
 - Connect the main electrical supply.
Check maximum permitted voltage value (→ # 30). Check proper use of residual-current circuit breakers (RCD, (→ # 47)
 - Connect the PC (→ # 82) for setting up the drive system.
4. Check the wiring against the wiring diagrams and observe the system topology limits (→ # 60).

9.3 EMI Noise Reduction



CAUTION Electromagnetic Fields!

Electromagnetic radiation may, by acting on electrically conductive materials, lead to potential hazardous danger (warming, loss of implants).

- Work on the electrical installation may only be performed by trained and qualified personnel, in compliance with the regulations for safety at work, and only with switched off mains supply, and secured against restart.
- Grounding, equipotential bonding and radiation-reducing shields may not be removed.

9.3.1 Recommendations for EMI noise reduction

The following guidelines will help you to reduce problems with electrical noise in your application.

- **Ensure good connections between the cabinet components.**
Connect the back panel and cabinet door to the cabinet body using several conductive braids. Never rely on hinges or mounting bolts for ground connections. Provide an electrical connection across the entire back surface of the AKD-C panel. Electrically-conductive panels such as aluminum or galvanized steel are preferred. For painted and other coated metal panels, remove all coating behind the drive.
- **Ensure good ground connection.**
Connect from cabinet to proper earth ground. Ground leads should be the same gauge as the leads to main power or one gauge smaller.
- **Use Kollmorgen cables.**
Experience has shown that customers who use Kollmorgen's cables have far fewer problems than customers who build cables.
Route power and control cables separately, Kollmorgen recommends a distance of at least 200 mm to improve interference immunity.
- **Ground the shielding at both ends.**
Ground all shielding with large areas (low impedance), with metalized connector housings or shield connection clamps wherever possible. For cables entering a cabinet, connect shields on all 360° of the cable. Never connect a simple "pigtail".
- **Splice cables properly.**
If you need to divide cables, use connectors with metal backshells. Ensure that both shells connect along the full 360° of the shields. No portion of the cabling should be unshielded. Never divide a cable across a terminal stripe

9.3.2 System Grounding

Ensure the proper grounding of all components with the PE rail in the control cabinet as reference potential. Connect each ground individually with the intended grounding cable (neutral point connection).

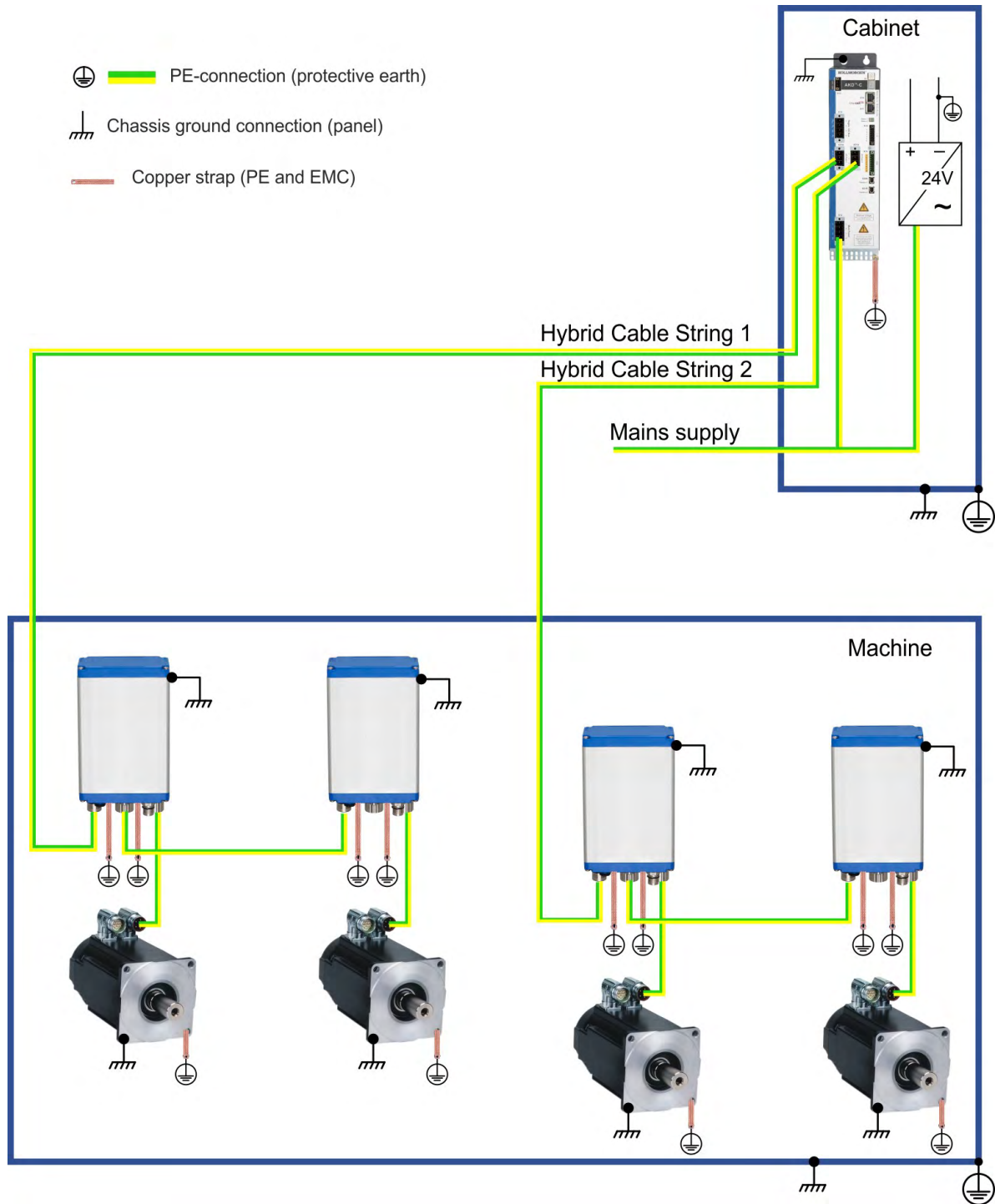

Protective Earth (PE)

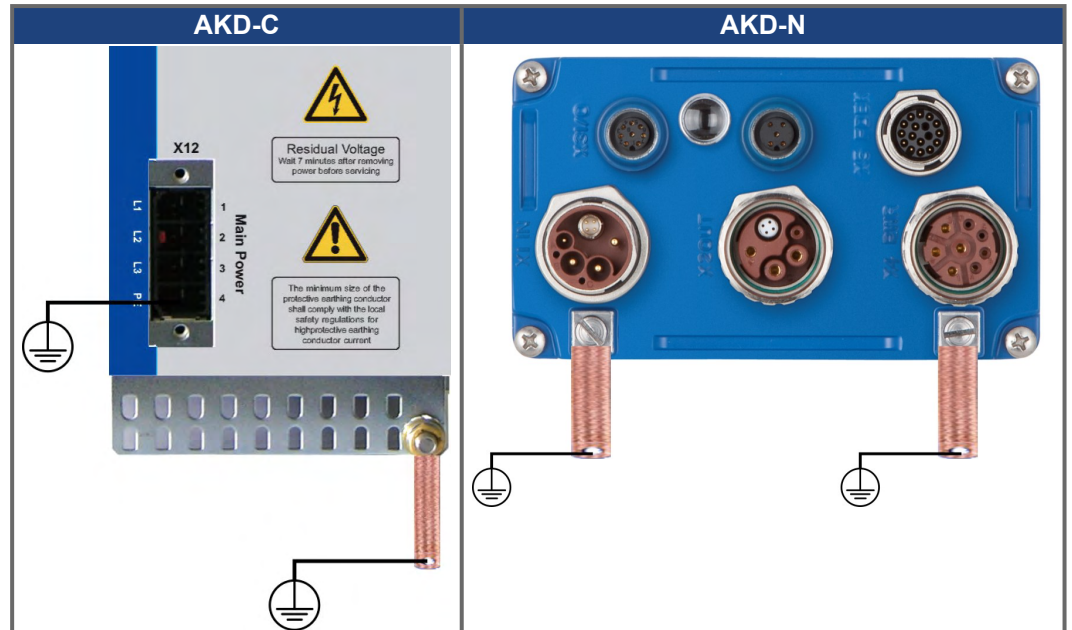

The leakage current against PE is more than 3.5 mA. In accordance with EN 61800-5-1, the PE connection must therefore either be double implemented or a connection cable with $>10\text{mm}^2$ cross-section used.

NOTICE

Wire the PE connections immediately after installing the devices as the first electrical connection. Only after that may you insert all the other plug connectors. For disassembly, release the PE connections as the last connection.

AKD-C

Use the PE terminal (X12) and the PE pin. The double connection is thus ensured. In order to keep the impedance as low as possible, we recommend a copper earthing strap for the PE connection on the PE pin.

AKD-N

Use both PE connections. To keep impedance as low as possible, we recommend copper earthing straps for the PE connections.

9.3.3 Shielding connection to the device

9.3.3.1 Shield connection clamps for X12, X13, X14, X15, X16

Shield connection clamps (see accessories manual) are used for connecting cable shields for X12, X13, X14, X15, X16.

NOTE Usually wiring to these connectors must not be shielded.

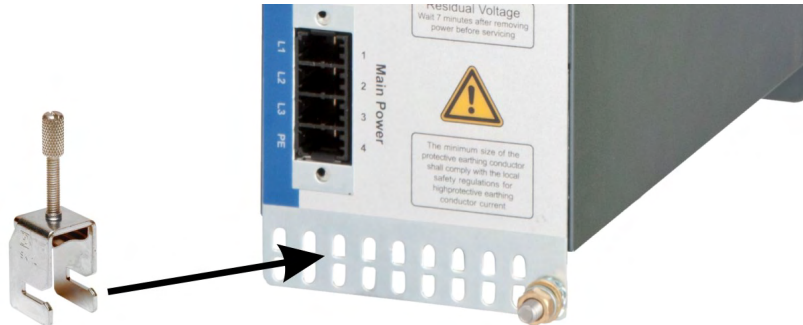

We recommend using Phoenix Contact SK14 shield clamps with clamp range of 6 to 13mm. The clamps hook into the grounding plate and ensure optimum contact between the shield and the grounding plate.

9.3.3.2 Ethernet connectors X10, X11, X18

The shield of Ethernet cables is connected via the connectors to the housing.

9.3.3.3 DC power connector X20A, X21A (cable CCNCN1)

Connection for the DC power by mating connector with strain relief.

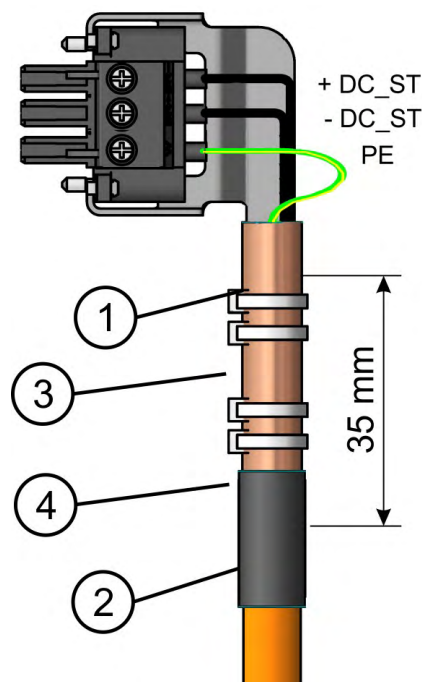

1. Strip the external cable sheath to a length of approx. 100mm, taking care not to damage the braided shield.
2. Push the braided shield (1) back over the cable and secure with a rubber sleeve (2) or shrink sleeve.
3. Shorten all the wires apart from the protective earth (PE) wire (green/yellow) by about 20mm so that the PE wire is now the longest wire.
4. Strip all wires and fit wire end ferrules.
5. Secure the braided shield of the cable to the shroud with a cable tie (3) and use a second tie (4) to fasten the cable.
6. Wire the connector as shown in the connection diagram.
7. Plug in the connector to the socket on the front of the AKD-C.
8. Screw the connector in place. This ensures that there is conductive contact over a large surface area between the braided shield and the front panel.

The DC power is now connected.

9.3.3.4 Local fieldbus connectors X20B, X21B (cable CCNCN1)

The shield of local fieldbus cables is connected via the connector to the housing.

9.4 System Topology of a Decentralized Servo System

9.4.1 System limits

String length:	maximum 100 m total cable length per string
Number of AKD-N:	maximum 8 per string, total maximum 16 observe total power/current restrictions described in the <i>Decentralized System Project Guide</i>
Number of AKD-C:	limited by fieldbus protocol
Sum of output current of string 1 and string 2:	17 A, use coincidence factor of the axes for optimization
Standby total power:	Total standby power is limited to 260 W at 24 V.
Service Interface X18	Ethernet TCP/IP, 100 Mbit/s

9.4.2 Example for one AKD-C

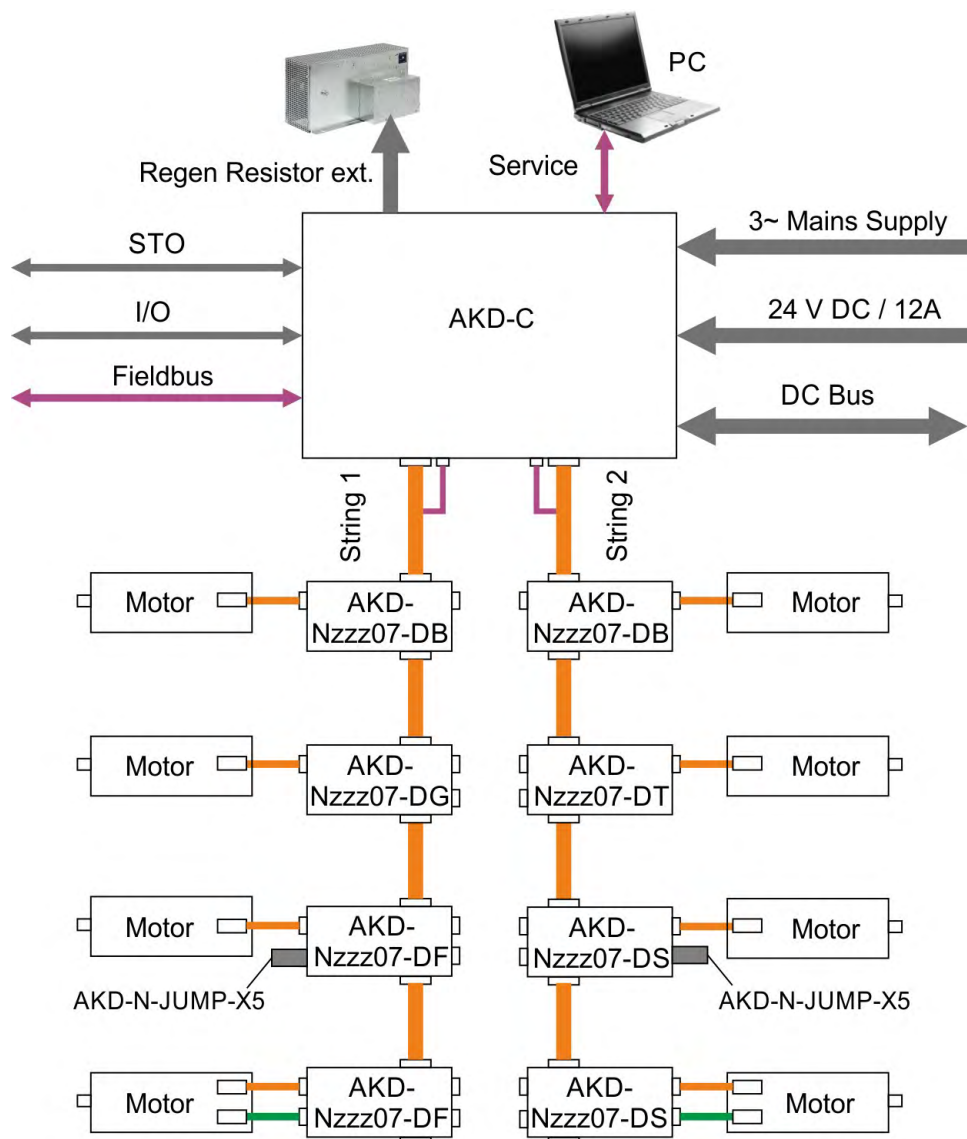

9.4.3 Example for several AKD-C

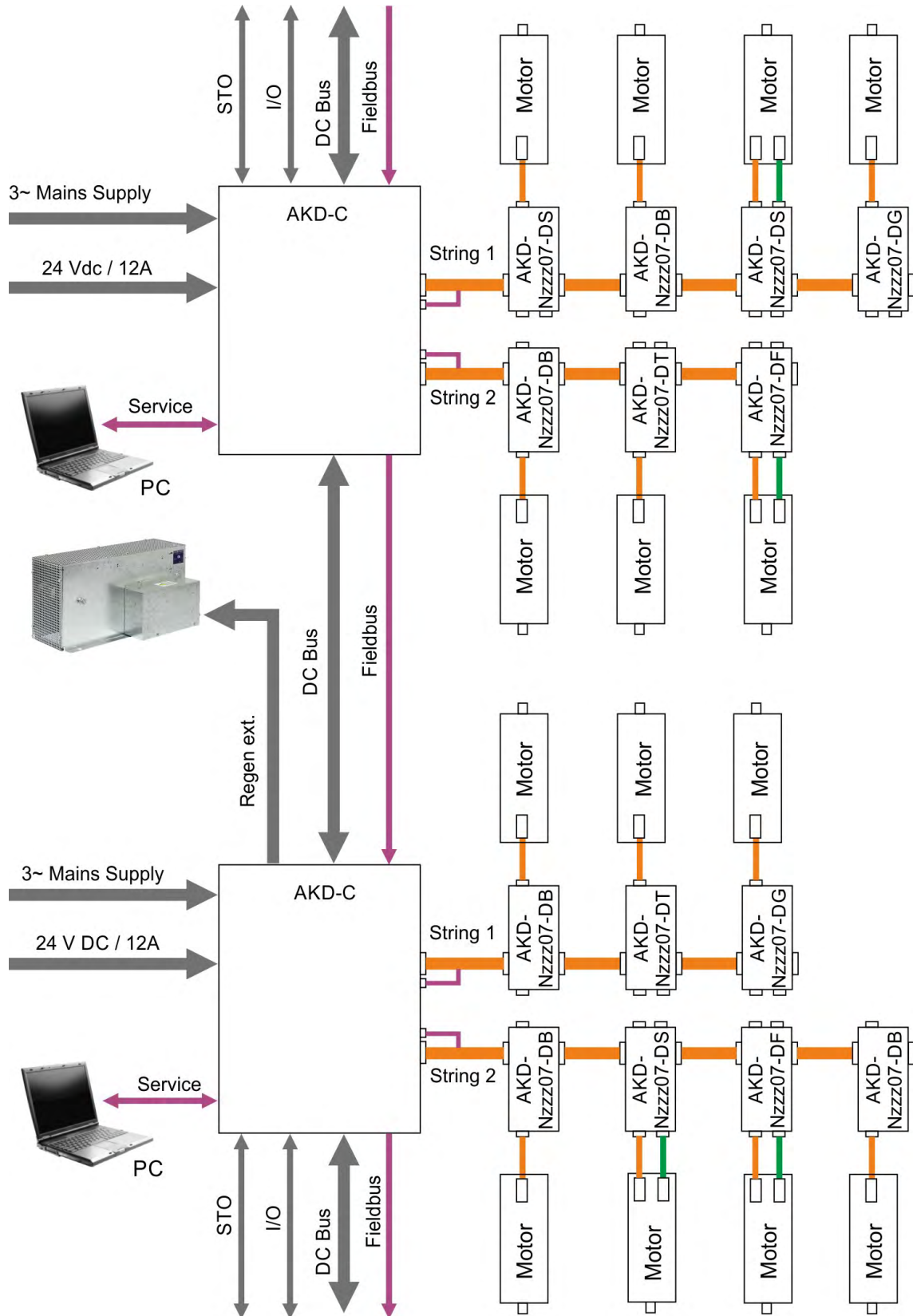

9.5 Wiring



⚠ DANGER High Voltage up to 900 V!

There is a danger of serious personal injury or death by electrical shock or electrical arcing.

- Only install and wire the equipment when it is not live, that is, when neither the electrical supply nor the 24 V auxiliary voltage nor the supply voltages of any other connected equipment is switched on.
- Make sure that the cabinet is safely disconnected (for instance, with a lock-out and warning signs). The individual voltages are switched on for the first time during setup.

NOTICE

Only professional staff who are qualified in electrical engineering are allowed to install the decentral drive system. Wires with color green with one or more yellow stripes must not be used other than for protective earth (PE) wiring. When installing or replacing cables, use only standardized components, which complies to the specifications in chapter 7.10 "Cable Requirements".

NOTE

The ground symbol, which you will find in the wiring diagrams, indicates that you must take care to provide an electrically conductive connection with the largest feasible surface area between the unit indicated and the mounting plate in the control cabinet. This connection is for the effective grounding of HF interference, and must not be confused with the PE-symbol (PE = protective earth, safety measure as per IEC 60204).

Use the following connection diagrams:

Overview AKD-C	(→ # 64)
Mains supply	(→ # 66)
24 VDC supply	(→ # 67)
DC bus link	(→ # 68)
Drive string connection	(→ # 74)
Digital I/O	(→ # 77)
Motion Bus	(→ # 81)
Service interface	(→ # 82)

9.6 Connection Overview

9.6.1 Connector assignment

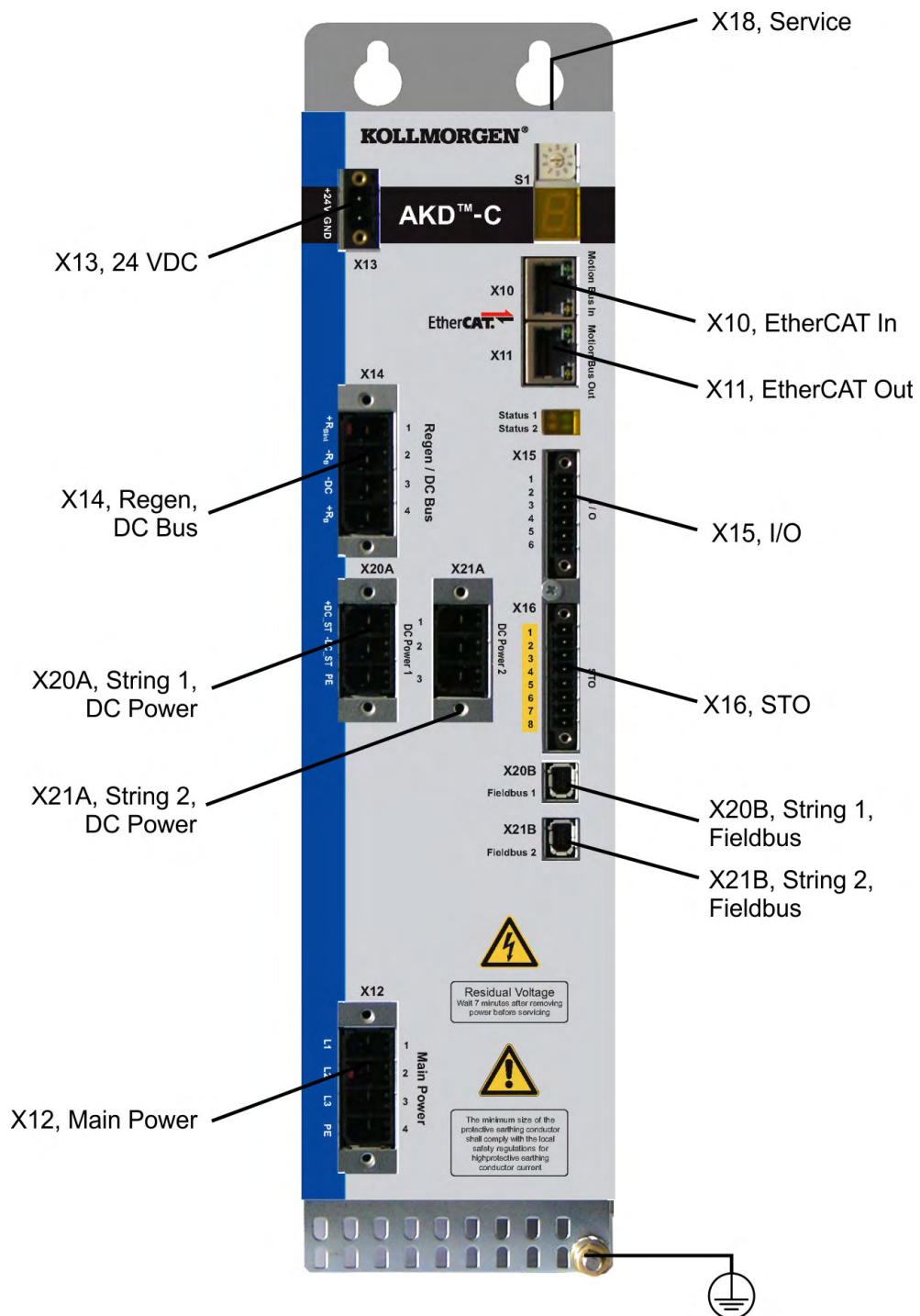

9.6.2 Connection diagram

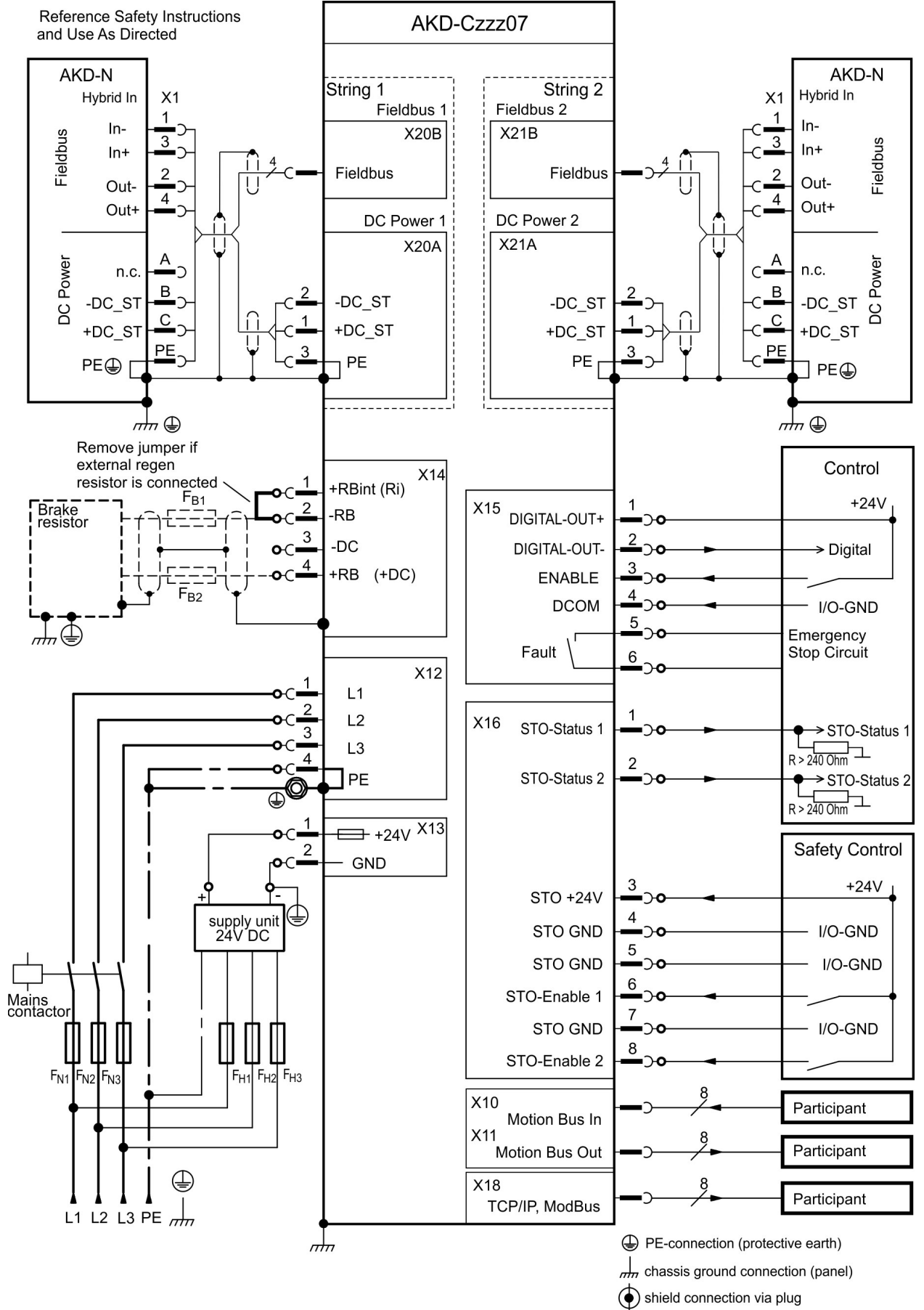

9.7 Electrical Supply Connection

9.7.1 Connection to various mains supply networks

This page illustrates all the possible connection variations for different electrical supply networks.

NOTICE

An isolating transformer is required for 120V/240V networks to get a minimum voltage of 400V -10%.

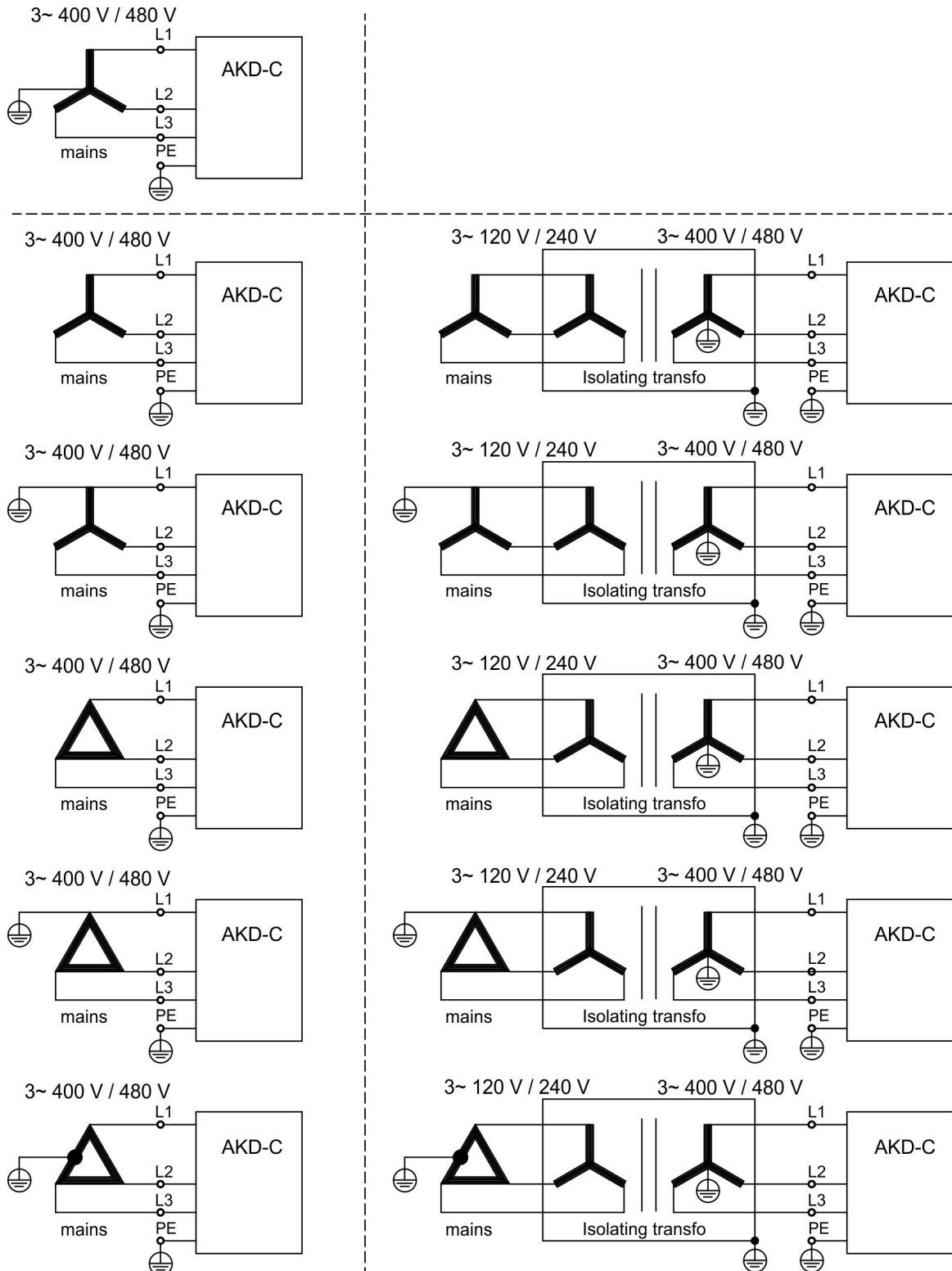

9.7.2 Mains supply connection (X12)

9.7.2.1 Three phase connection

- Directly to 3-phase supply network, supply networks (→ # 65)
- Fusing (such as fusible cut-outs) to be provided by the user (→ # 31).

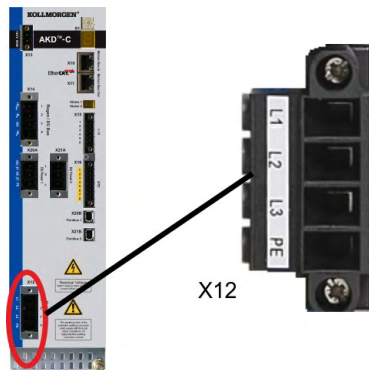
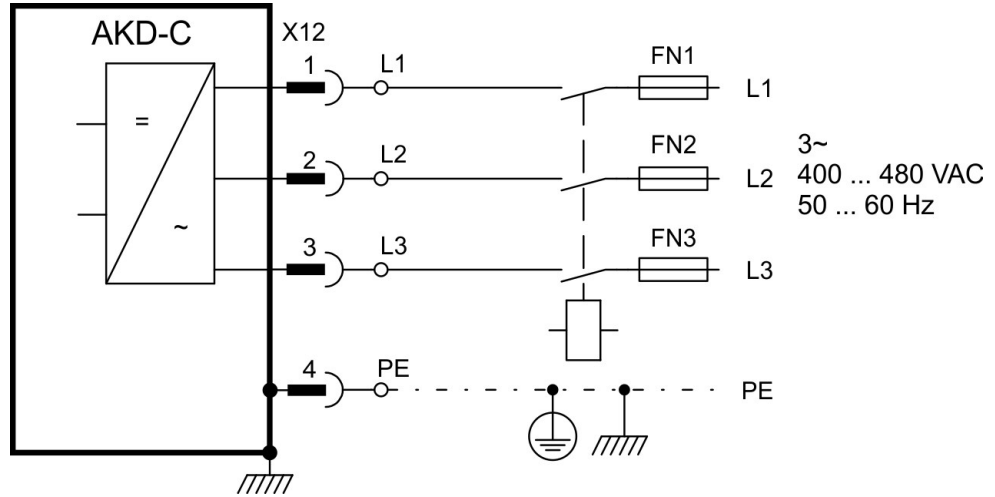

Pin	Signal	Description
1	L1	Line 1
2	L2	Line 2
3	L3	Line 3
4	PE	Protective Earth

9.7.3 24 VDC supply voltage (X13)

The following diagram describes external 24 VDC power supply, electrically isolated, for example, via an isolating transformer. The required current rating depends on the use of motor brake and number of connected AKD-N drives.

The 24 VDC voltage is internally split into a control supply to power the AKD-C electronics and a supply voltage to power the connected AKD-N drives in case of switched off AC mains power.

NOTE Standby power is limited to 260 W at 24 V for both strings. This power must supply all AKD-N (8 W each) and the remaining power can be used for motor holding brakes.

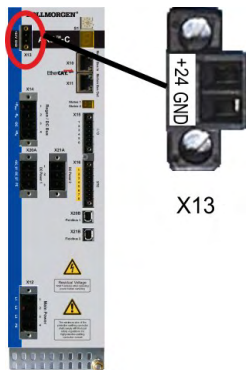
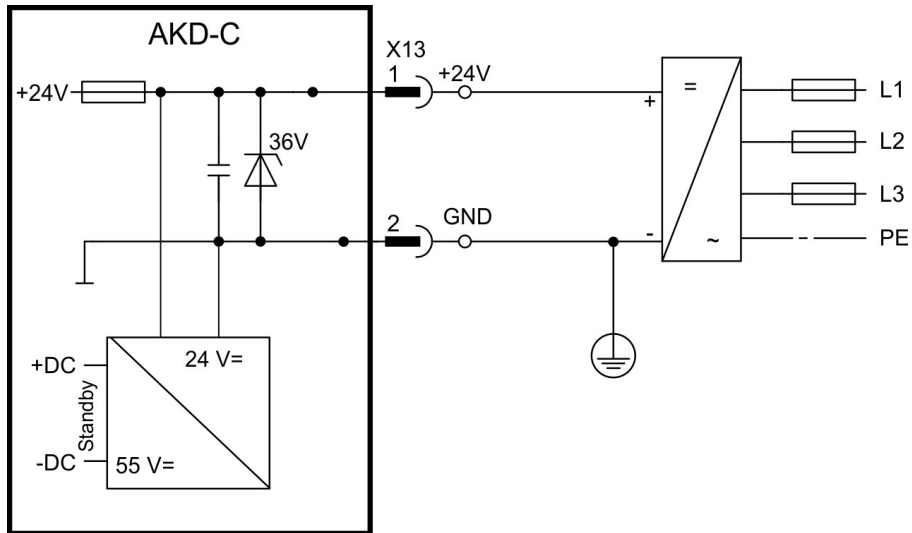

Pin	Signal	Description
1	+24	+24 VDC Auxiliary voltage
2	GND	24V Supply GND

9.8 DC Bus link (X14)

The DC bus link can be connected in parallel so that the regen power is divided between all the AKD-C that are connected to the same DC bus link circuit. Every AKD-C must have it's own power connection to mains voltage, even if the DC bus link is used.

NOTICE

The devices can be destroyed if DC bus link voltages are different. Only devices with mains supply from the same mains (identical mains phases and voltage) may be connected by the DC bus link. Use unshielded single cores with a maximum length of 200 mm. Use shielded cables for longer lengths.

NOTICE

The DC-Bus link circuit +DC/-DC is not short circuit proof. Observe the recommended wire cross section (→ # 33).

Possible DC Bus Link connections

Devices	AKD-xzzz07	KCM	AKD-xzzz06	S3xx / S7xx
AKD-C01007	yes	yes	no	no

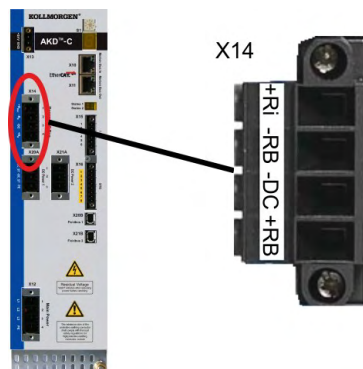
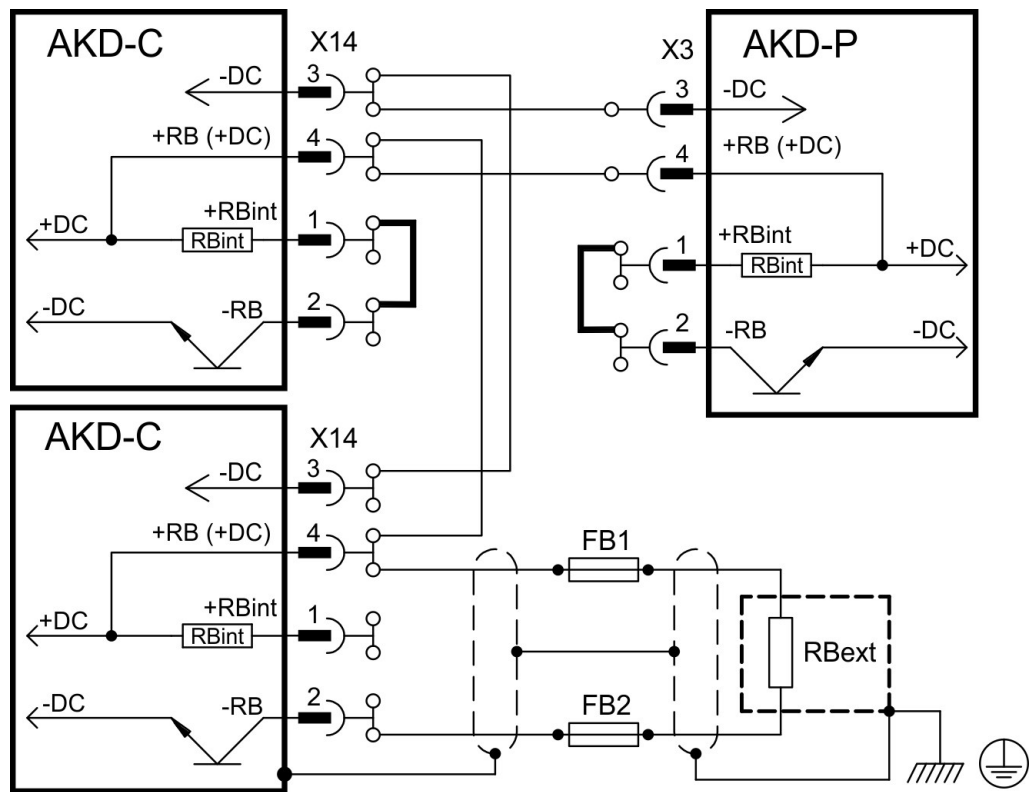

Pin	Signal	Description
3	-DC	DC-Link Bus negative
4	+DC (+RB)	DC-Link Bus positive

9.8.1 Regen resistor (X14)

9.8.1.1 Internal regen resistor

AKD-C has a built-in regen resistor. This internal brake circuit is active with the plugged bridge in mating connector X14 between 1 (+RB_i) and 2 (-RB).

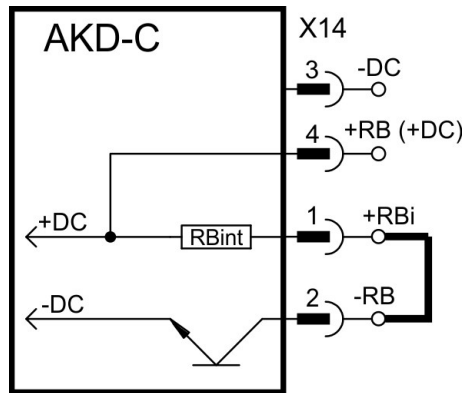

9.8.1.2 External regen resistor

For technical data on the brake circuit (→ # 36). Fusing (such as fusible cut-outs) to be provided by the user (→ # 31).

NOTICE

The brake circuit +RB/-RB is short circuit proof. Observe the prohibition of continuous, operational short circuits to the external regen resistor contacts (→ # 16).

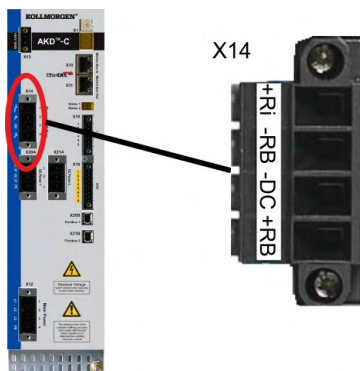
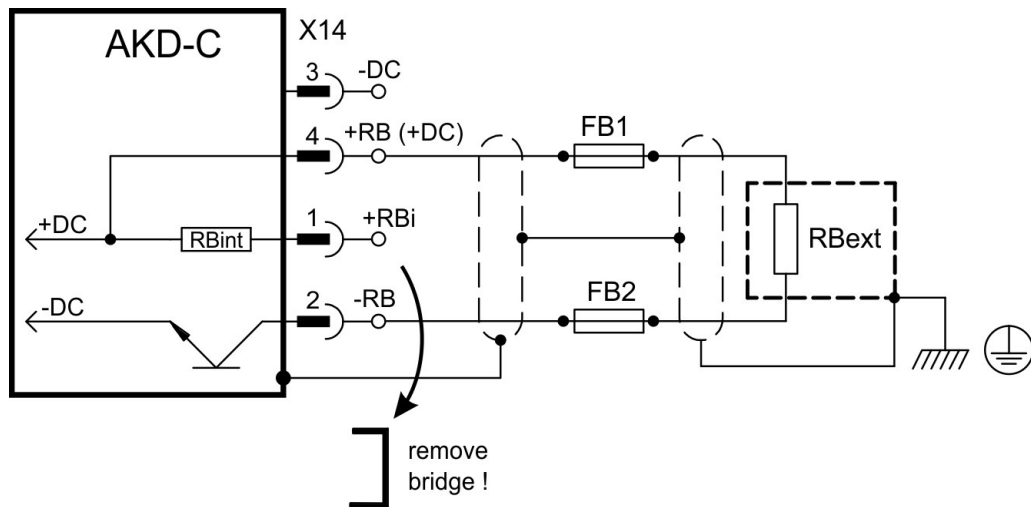

Pin	Signal	Description
2	-RB	External Regen Resistor negative
4	+RB	External Regen Resistor positive

9.8.2 Capacitor Modules (X14)



KCM modules (**K**OLL**M**OR**G**EN **C**apacitor **M**odules) absorb kinetic energy generated by the motor when it is operating in generator mode. Normally, this energy is dissipated as waste via regen resistors. KCM modules, however, feed the energy they have stored back into the DC Bus link as and when it is required.

Assembly information: see regional accessories manual or KCM instruction manual.

Dimensions (HxWxD): 300x100x201 mm

KCM-S	Saves energy: The energy stored in the capacitor module during generative braking is available the next time acceleration happens. The module's inception voltage is calculated automatically during the first load cycles.
KCM-P	Power in spite of power failure: If the power supply fails, the module provides the servo amplifier with the stored energy that is required to bring the drive to a standstill in a controlled manner (this only applies to the power supply voltage; battery-back the 24 V supply separately).
KCM-E	Expansion module for both applications. Expansion modules are available in two capacitance classes.

NOTE

The KCM modules may only be connected to AKD with 400/480 V rated voltage. Mounting, installation, and setup instructions can be found in the Instructions Manual of the KCM Modules.



⚠ DANGER High DC Voltage up to 900 V!

There is a danger of serious personal injury or death by electrical shock or electrical arcing. It can take over an hour for the modules to self-discharge.

- Switch off (disconnect) the line voltage. You must only work on the connections when the system is disconnected.
- Check the state of charge with a measuring device that is suitable for a DC voltage of up to 1,000 V.
- When measuring a voltage of over 50 V between the DC+/DC- terminals or to ground, discharge the modules (see (→ # 73).

9.8.2.1 Technical Data

Type	Storage-Capacity [Ws]	Rated Supply Voltage [V DC]	Peak Supply Voltage [V DC]	Power [kW]	Protection Class	Inception Voltage [V DC]	Weight [kg]
KCM-S200	1600	max. 850	max. 950 (30s in 6 min)	18	IP20	evaluated	6.9
KCM-P200	2000					470	6.9
KCM-E200	2000					-	4.1
KCM-E400	4000					-	6.2

9.8.2.2 Example installation with KCM-S and KCM-E

NOTICE

Maximum cable length between AKD-C and KCM: 500mm. The DC+ and DC- lines should always be twisted, maximum cross section is 6mm². Ensure that the polarity is correct, swapping round DC+/DC- will damage the KCM modules.

Create a motion profile that causes the brake chopper to respond.

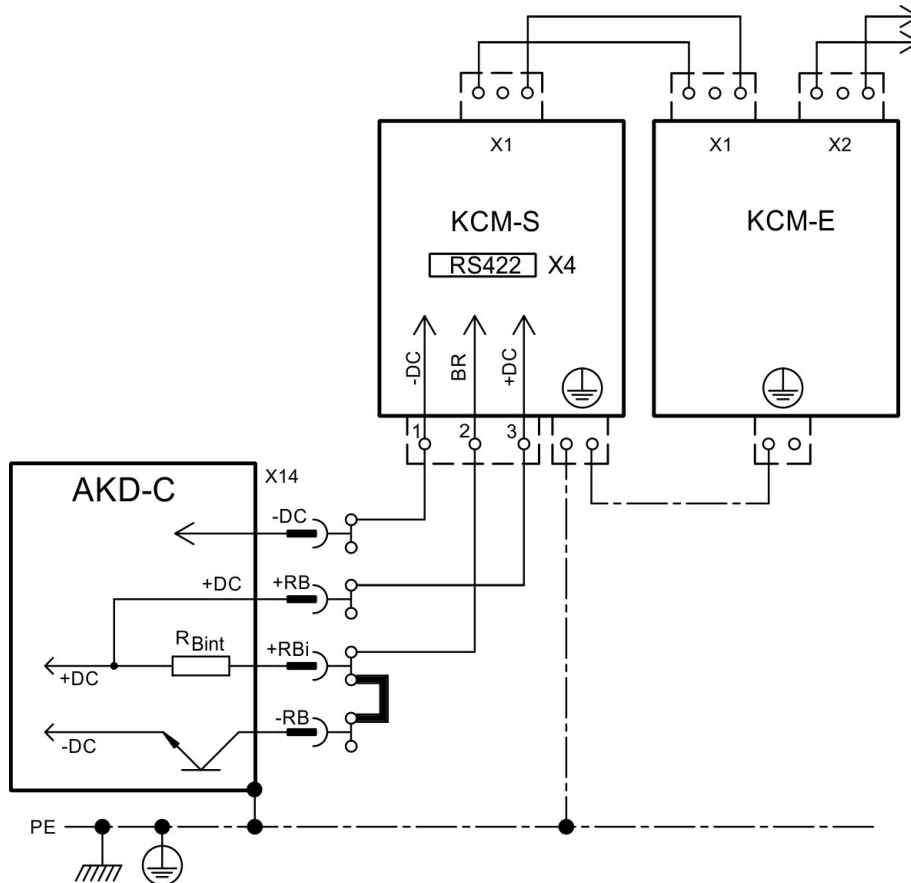

Setup KCM-S and KCM-E

Prerequisite for the following instructions:

- Properly disconnected, grounded system.
- KCM-S: assembled and wired in the switching cabinet. The load that leads to the activation of the brake chopper during braking must be connected.
- KCM-E: assembled and connected to the KCM-S with connection cable (X1) and PE line.
- Discharge aids (plug-in bridge) are removed.

Proceed as instructed below:

1. Switch on the line voltage after the AKD-C has finished the 24V boot process.
2. Enable the AKD and operate the motion profile that causes the brake chopper to respond.
3. The KCM-S determines the chopper threshold and begins to charge; LED (top view) flashes. The energy stored in the capacitor module during generative braking is available the next time acceleration happens.

RS422 interface X4 allows data exchange controlled by a terminal software of your choice. Interface setting: 115200 Baud, 8 Data Bits, 1 Stop Bit, No Parity&Flow Control.

The X4 mating connector is in the package. More information is given in the KCM Instructions Manual.

9.8.2.3 Example installation with KCM-P and KCM-E

NOTICE

Maximum cable length between AKD-C and KCM: 500mm. The DC+ and DC- lines should always be twisted, maximum cross section is 6mm². Ensure that the polarity is correct, swapping round DC+/DC- will damage the KCM modules.

The KCM-P starts the charging process at approx. 470 V DC. If the power supply fails, the module provides the DC bus link with the stored energy (this only applies to the power supply voltage; battery-back the 24 V supply separately).

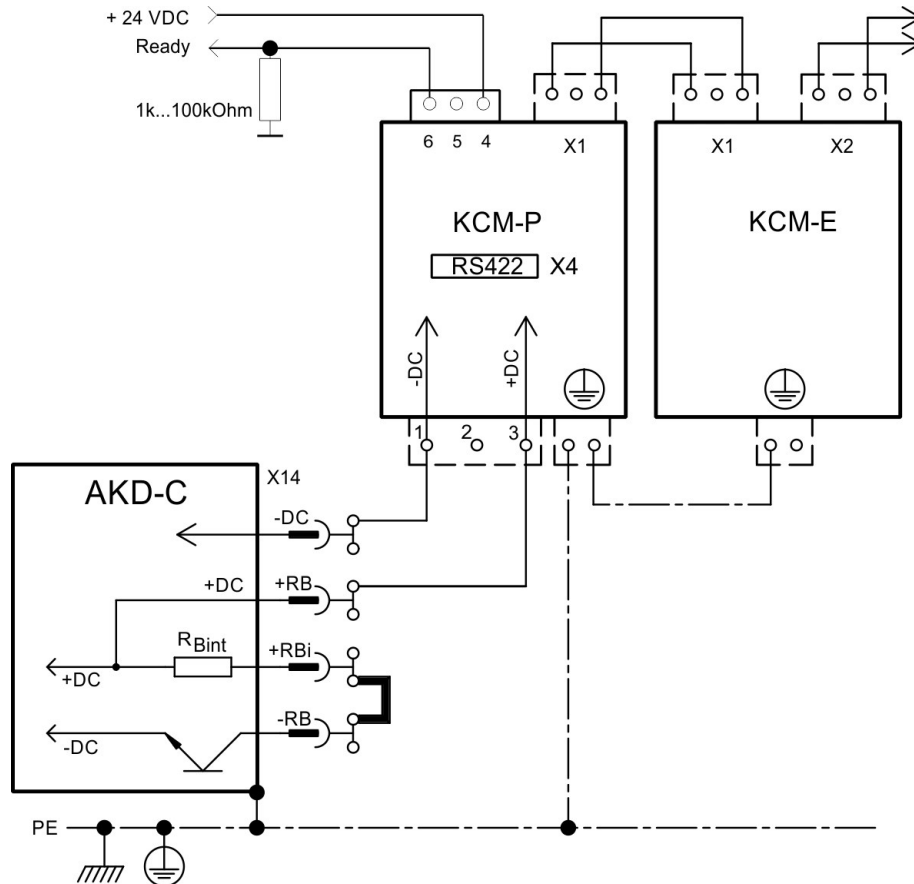

Setup KCM-P and KCM-E

Prerequisite for the following instructions:

- Properly disconnected, grounded system.
- KCM-P: assembled and wired in the switching cabinet. Set AKDundervoltage limit VBUS.UVTHRESH to a value significantly below 470V DC, otherwise AKD will switch-off before KCM-P provides energy to the DC bus link.
- KCM-E: assembled and connected to the KCM-P with connection cable (X1) and PE line.
- Discharge aids (plug-in bridge) are removed.

Proceed as instructed below:

1. Switch on the line voltage after the AKD-C has finished the 24V boot process.
2. The KCM-P begins the charging process at approx. 470 V DC; the LED flashes.

RS422 interface X4 allows data exchange controlled by a terminal software of your choice. Interface setting: 115200 Baud, 8 Data Bits, 1 Stop Bit, No Parity&Flow Control. The X4 mating connector is in the package.

The ready signal reports the ready to operate (high level) status.

More information is given in the KCM Instructions Manual.

9.8.2.4 Discharging KCM modules

The aids supplied with each KCM module (plug-in bridge/connecting cables) allows discharging the modules safely.

NOTICE

When the charging LED on top of the modules flashes, the capacitors are charged. Please note, however, that the LED does not allow you to draw a definite conclusion about the state of discharge, as it is not monitored for failures.



DANGER High DC Voltage up to 900 V!

There is a danger of serious personal injury or death by electrical shock or electrical arcing.

- Switch off (disconnect) the line voltage. You must only work on the connections when the system is disconnected.
- Check the state of charge with a measuring device that is suitable for a DC voltage of up to 1,000 V.
- Wait until the voltage measured between the DC+/DC- terminals or to ground has dropped below 50 V.
It can take over an hour for the modules to self-discharge.
- If you cannot wait for the duration of the self-discharge time, you must force the modules to discharge.
- Follow the procedure described below when forcing the modules to discharge.

For your own safety, proceed as follows when forcing the modules to discharge:

1. Switch off (disconnect) the line voltage and the 24V voltage.
2. Discharge the modules:
 - KCM-S/-P:** Insert the plug-in bridge in the screw terminals (black-1 to gray-2) on the base of the modules, wait at least 70 s, leave the plug-in bridge in place (as a means of securing for transport). Remove the plug-in bridge again before recommissioning.
 - KCM-E:** Bridge the X2/X3 connector with a connecting cable on the top of the module, wait at least 70 s, leave the connecting cable in place (as a means of securing for transport). Detach the connecting cable and reconnect the KCM-E properly before recommissioning.
3. Perform the scheduled task (e.g., cleaning, maintenance, or uninstallation).

9.9 Drive String Connection

AKD-C support two strings to connect up to 16 AKD-N drives.

NOTE

Use IP67 grommets for leading the hybrid cable out of the cabinet.

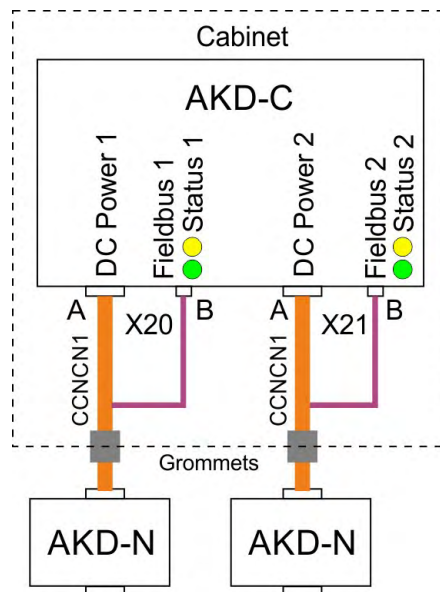

For connecting the first AKD-N to one of the DC strings the Kollmorgen cable type CCNCN1 must be used. This cable is a Y type adapter with one hybrid connector on the AKD-N end and two connectors on the AKD-C end with separate DC power and local fieldbus lines.

To ensure protection class IP67, Kollmorgen recommends cable entry system KDL/S combined with cable entry grommet KDT/S manufactured by:

Murrplastik Systemtechnik GmbH
 Fabrikstraße 10
 71570 Oppenweiler, Germany
 Phone: +49 (0)7191 482-0
 Website: www.murrplastik.de
 E-Mail: info@murrplastik.de

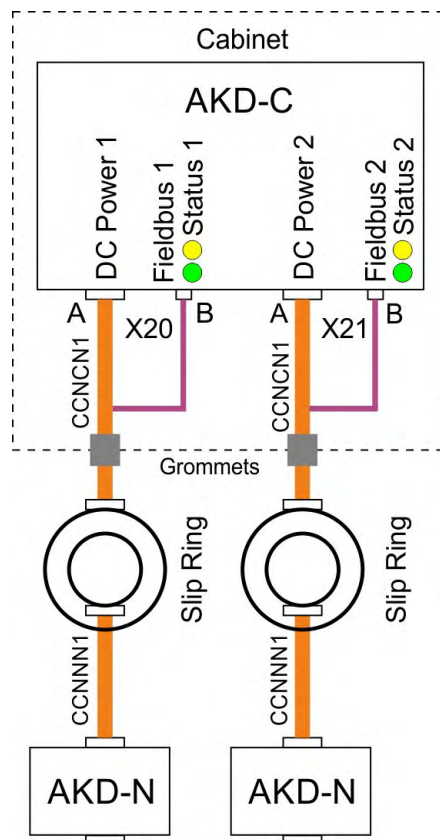

Solution for rotary tables

If AKD-N must be mounted on a rotary table, it is necessary to use slip ring assemblies for energy and data transfer between AKD-C in the cabinet and AKD-N on the rotary table.

Kollmorgen cooperates with company STEMMANN-TECHNIK for user specific slip ring assembly solutions.

Please contact:

STEMMANN-TECHNIK GmbH
 Niedersachsenstraße 2
 48465 Schüttorf, Germany
 Phone: +49 (0)592381-0
 Website: www.stemmann.com
 E-Mail: sales@stemmann.de

The Safety Function STO has been tested with STEMMANN slip rings 6263576 and 6263577.

These slip rings can be used as stand-alone modules or in a slip ring cassette.

9.9.1 String assignment

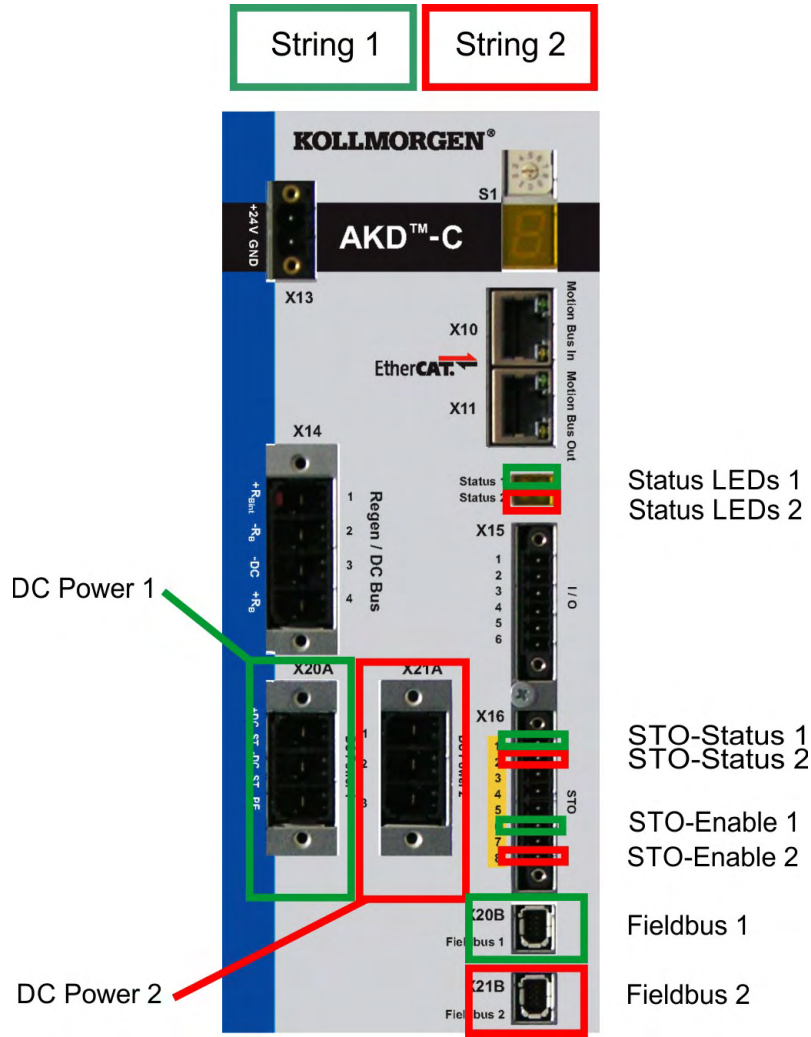

9.9.2 DC power (X20A, X21A)

The DC power lines supply DC power for up to 8 AKD-N drives in one string. Connection for the DC power must be done by a mating connector with strain relief due to EMC reasons. This connector is configured with the Kollmorgen CCNCN1 cable (→ # 33).

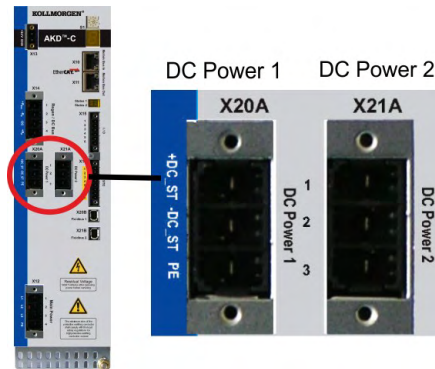

Pin	Signal	Description
1	+DC_ST	DC power positive
2	-DC_ST	DC power negative
3	PE	Protective Earth

9.9.3 Local Fieldbus (X20B, X21B)

Local fieldbus connectors separate for each string enable the AKD-C to communicate with all connected AKD-N via a four line bus medium. This connector is configured with the Kollmorgen CCNCN1 cable (→ # 33).

NOTICE

These ports may not be directly connected to standard EtherCAT nodes. These connectors are type 1 mini I/O, use Kollmorgen cables CCNCN1 only.

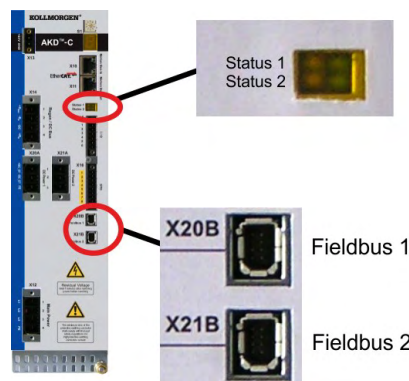

Pin	Signal	Description
1	Receive +	Receive +
2	Receive -	Receive -
3	Transmit +	Transmit +
6	Transmit -	Transmit -
4,5,7,8	n.c.	not connected

Status LEDs for the local fieldbus connections

The communication status is indicated by the built-in status LEDs, one pair for each string.

LED	Name	Function
green	IN port Link	ON = active, OFF= not active
yellow	RUN	ON = running, OFF = not running

9.10 I/O Connection

9.10.1 I/O connectors X15 and X16

Digital I/O signals are connected to X15, STO signals are connected to X16.

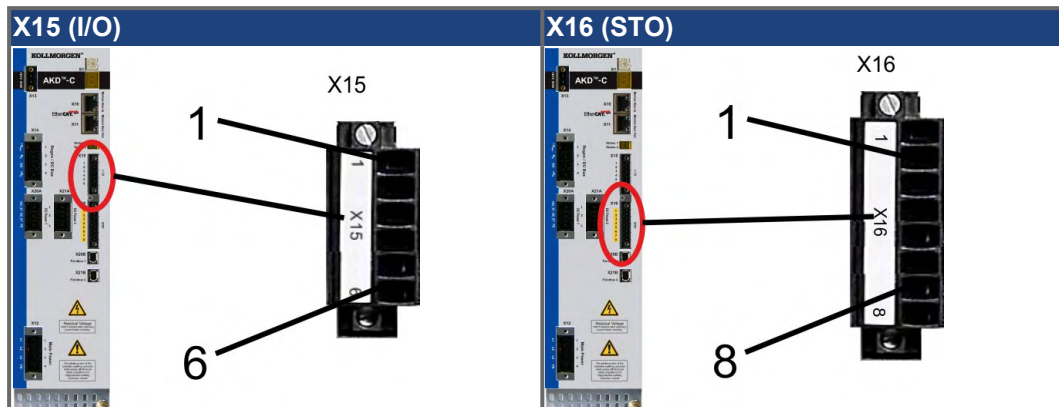

Conn.	Pin	Signal	Abbreviation	Function	Wiring Diagram
X15	1	Digital Output +	DIGITAL-OUT+	Programmable	(→ # 79)
X15	2	Digital Output -	DIGITAL-OUT-		
X15	3	Hardware Enable	Enable	Output stage enable	(→ # 78)
X15	4	Digital Common	DCOM	Common line for X15 pin 1, 2, 3	
X15	5	Fault Relay Output	Fault	Fault Relay Output	(→ # 80)
X15	6	Fault Relay Output	Fault	Fault Relay Output	
X16	1	STO-Status for DC Power String 1	STO-Status 1	Status of STO for string 1	(→ # 80)
X16	2	STO-Status for DC Power String 2	STO-Status 2	Status of STO for string 2	
X16	3	STO +24 VDC	STO +24 V	24 VDC for STO signals	
X16	4	STO GND	STO GND	GND for STO 24 V	
X16	5	STO GND	STO GND	GND for STO 24 V	
X16	6	STO-Enable for DC Power String 1	STO-Enable 1	Switches off torque for drives in string 1	
X16	7	STO GND	STO GND	GND for STO 24 V	
X16	8	STO-Enable for DC Power String 2	STO-Enable 2	Switches off torque for drives in string 2	

The DCOM line should be connected to the 0V of the I/O supply when using sensors of type "Source" with digital inputs.

The DCOM line should be connected to the 24V of the I/O supply when using sensors of type "Sink" with digital inputs.

9.10.2 Digital Input (ENABLE, X15)

Digital Input (terminal X15/3) is set to the Hardware Enable function.

Technical characteristics:

- Floating, reference common line is DCOM
- Sink or Source type wiring is possible
- As per IEC61131-2 type 1
- ON: 15 VDC to 30 VDC, 2 mA to 15 mA, OFF: -3 VDC to 5 VDC, < 1 mA
- Galvanic isolation for 250 VDC
- Update rate: direct connection to hardware (FPGA)

NOTE

The Hardware Enable input and the Software Enable signal (via fieldbus or WorkBench) are serial, that means wiring of Hardware Enable is mandatory.

The output stage of the AKD-N drives, which are connected to the AKD-C are enabled by applying the ENABLE signal (Terminal X15/3). Enable is possible only if the input STO-Enable 1 or 2 (valid for DC power strings 1 or 2) has a 24 V signal (→ # 39). In the disabled state the connected motor has no torque.

A software enable by means of the setup software is also required (AND link), although this can also be permanently enabled with WorkBench.

The input can be used with switched +24 V (source type) or switched GND (sink type). See diagrams below for typical examples of digital input wiring.

Digital Input Wiring Diagram (Source type connection):

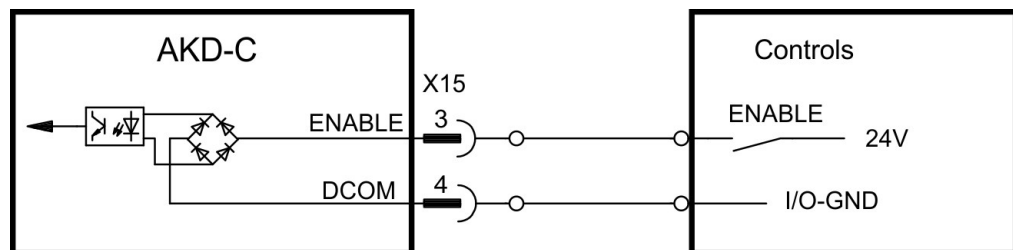

Digital Input Wiring Diagram (Sink type connection):

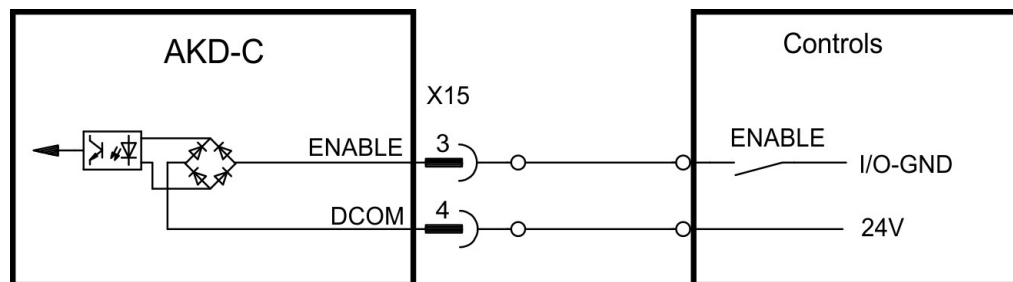

9.10.3 Digital Output (X15)

The drive supplies one digital output (X15/1 to X15/2, (→ # 77). Choose the required function in the setup software. Messages from pre-programmed functions stored in the AKD-C can be output here. A list of these pre-programmed functions can be found in the setup software. If the output is to be assigned to a pre-programmed function, then the parameter set must be saved in the AKD-C.

Technical characteristics:

- As per IEC61131-2 type 1
- Floating, max. 30 VDC, 100 mA
- Short circuit proof
- Galvanic isolation for 250 VDC
- Can be wired as active low or active high (see examples below)
- Update rate: 250 μ s

Wiring diagram:

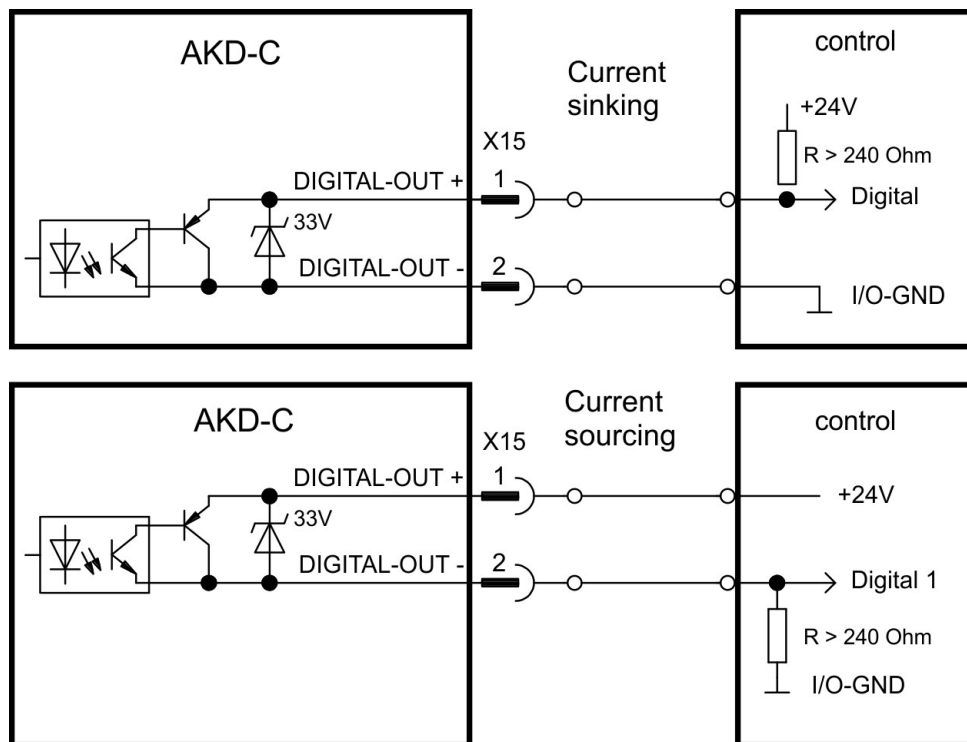

9.10.4 FAULT relay contacts

Operational readiness (terminals X15/5 and X15/6) is signaled by a floating relay contact.

The fault relay can be programmed to two modes of operation:

- Contact closed when there is no fault
- Contact closed when there is no fault and the drive is enabled.

The signal is not influenced by the enable signal, the I²t-limit, or the regen threshold.

Technical characteristics:

- FAULT: Relay output, max. 30 VDC or 42 VAC, 1 A
- Time to close: max. 10 ms
- Time to open: max. 10 ms

NOTE

All faults cause the FAULT contact to open and the AKD-N output stages to be switched off (if a fault occurs, the internal hardware ready signal is inhibited -> no power output to motors). List of the fault messages: (→ # 91).

Wiring diagram:

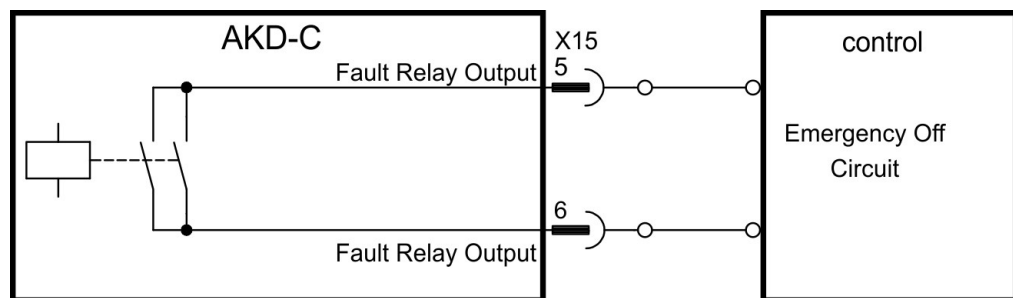

9.10.5 STO signals (X16)

Connector X16 offers access to all STO (Safe Torque Off) signals of the decentral drive system powered by this AKD-C . There is one STO-Enable input and one STO-Status output for each DC Power string. All STO signals are galvanically isolated and need external 24 VDC supply (PELV/SELF).

For detailed description of STO interface and functionality refer to (→ # 39).

9.11 Motion Bus Interface (X10/X11)

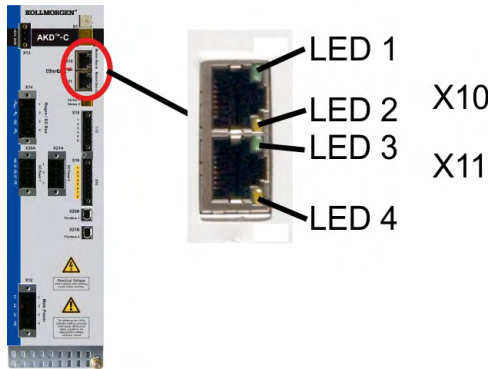

The motion bus interface has RJ45 connectors and can be used for communication with the EtherCAT master and other AKD-C.

NOTICE

Do not connect the Ethernet line for the PC or PAC with the set up software to the motion bus interface X10/X11. The set up Ethernet cable must be connected to X18.

9.11.1 Pinout

Pin	Signal X10	Signal X11
1	Transmit +	Receive+
2	Transmit -	Receive-
3	Receive+	Transmit +
4, 5	n.c.	n.c.
6	Receive-	Transmit -
7, 8	n.c.	n.c.

9.11.2 Bus Protocols

Protocol	Type	Connectivity Option
EtherCAT	Motion bus	EC

9.11.3 Network configuration



9.11.4 EtherCAT

AKD-C01007-CBEC can be connected as slaves to the EtherCAT network (CoE) via RJ45 connectors X10 (in port) and X11 (out port). The communication status is indicated by the built-in connector LEDs.

Connector	LED#	Name	Function
X10	LED1	IN port Link	ON = active, OFF= not active
	LED2	RUN	ON = running, OFF = not running
X11	LED3	OUT port Link	ON = active, OFF = not active
	LED4	-	-

9.12 Service Interface (X18)

Operating, position control, and motion-block parameters can be set up by using the setup software WorkBench on an ordinary commercial PC (→ # 87).

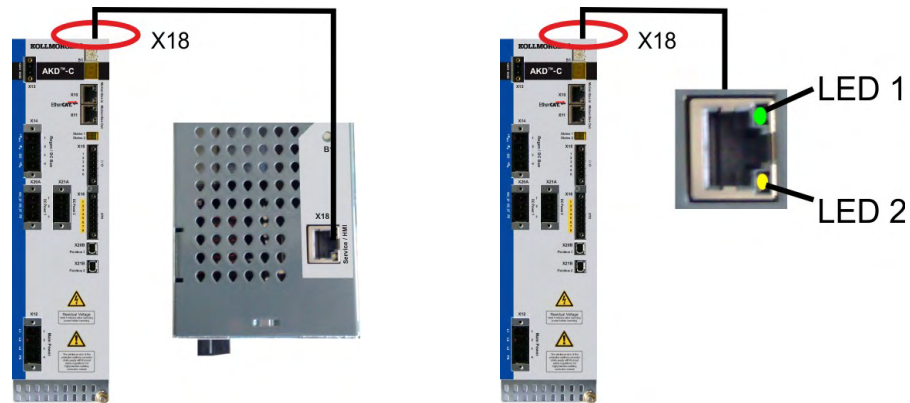

Connect the service interface X18 to an Ethernet interface on the PC directly or via a network switch. The cable can be connected/disconnected to X18 with power on. Confirm that the link LED on the AKD-C (the green LED on the RJ45 connector) and on your PC (or network switch) are both illuminated. If both lights are illuminated, then you have a good electrical connection.

NOTE

The X18 service port of an AKD-C does **not** allow access to AKD-N drives connected to other AKD-C devices.

9.12.1 Pinout

Pin	Signal	Pin	Signal
1	Transmit +	5	n.c.
2	Transmit -	6	Receive-
3	Receive+	7	n.c.
4	n.c.	8	n.c.

9.12.2 Service Bus Protocols

Protocol	Type
Ethernet TCP/IP	Service Bus, 100 Mbit/s

9.12.3 Possible Network Configurations

NOTE

Network hubs and transfer rate of 10 Mbit/s are not supported.

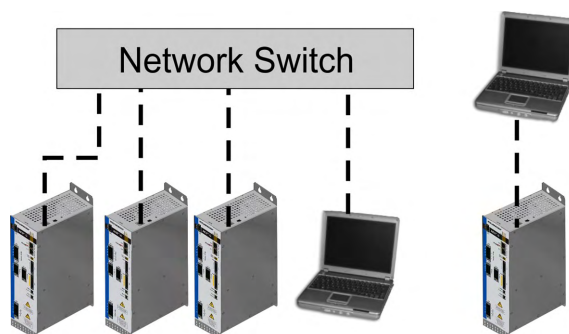

9.13 Push-button (B1)

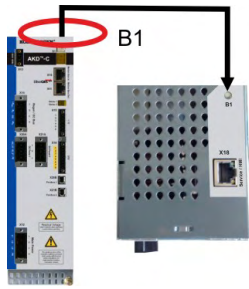

The push-button can be used to start predefined functions.

Press short to display the IP address in the LED display

9.14 Rotary Switches (S1), Setting IP address

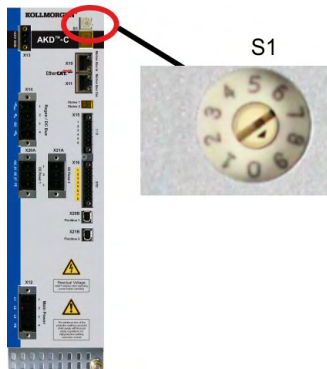

The configured IP address will be displayed on the 7 segment at Ethernet cable connection time and at power-on, if an Ethernet cable is connected. If no Ethernet cable is connected, no IP address will be indicated in the display.

More information is available in the AKD-C User Guide or in the Settings Screen-> Fieldbus-> TCP/IP screen in WorkBench.

NOTE Set S1 to 0 (zero) for DHCP/AutoIP address.

S1 Setting	AKD-C IP Address
0	DHCP/AutoIP address. The IP address of the AKD-C is obtained from the DHCP server on your network. If no DHCP server is found the IP addresses is an AutoIP address (it is internally generated following the AutoIP protocol and will be of the form 169.254.x.x).
1 to 9	Prepared for Static IP Address. Currently out of function.

NOTE The PC subnet mask must be set to 255.255.255.0 or 255.255.255.128

Dynamic IP addressing (DHCP and Auto-IP)

With S1 set to 0, the device is in DHCP mode. The AKD-C will acquire its IP address from an external DHCP server if present in the network. If a DHCP server is not present, the AKD-C will assume an Automatic Private IP Address of the form 169.254.x.x.

If your PC or PAC is directly connected to the AKD-C , and set to obtain an IP address automatically in the TCP/IP settings, a connection will be established with both devices using compatible automatic generated addresses. It can take up to 60 seconds for a PC to configure an Automatic Private IP Address (169.254.x.x).

Changing the IP address

If the switch is altered while 24 V Logic power is supplied to the AKD-C , you must switch off and then switch on again the 24 V supply voltage. This action will reset the address.

10 Setup

10.1 Important Notes	85
10.2 WorkBench Installation	86
10.3 Initial System Test	89
10.4 Fault and Warning Messages	91
10.5 Troubleshooting the AKD-C	92

10.1 Important Notes

NOTE

Before testing and setup, the manufacturer of the machine must generate a risk assessment for the machine and take appropriate measures so that unforeseen movements cannot cause injury or damage to any person or property.

NOTICE

Only professional personnel with extensive knowledge in the fields of electrical engineering and drive technology are allowed to test and set up the drive.



DANGER Lethal Voltage!

There is a danger of serious personal injury or death by electrical shock. Lethal danger exists at live parts of the device.

- Built-in protection measures such as insulation or shielding may not be removed.
- Work on the electrical installation may only be performed by trained and qualified personnel, in compliance with the regulations for safety at work, and only with switched off mains supply, and secured against restart.
- In normal operation, the cabinet door must be closed and the device must not be touched.



WARNING Automatic Start!

Risk of death or serious injury for humans working in the machine. The drive might restart automatically after power on, depending on the parameter setting. If parameter DRV.ENDEFAULT for one AKD-N is set to 1,

- then place a warning sign to the machine (Warning: Automatic Restart at Power On) and
- ensure, that power on is not possible, while humans are in a dangerous zone of the machine.

NOTICE

If the device has been stored for more than 1 year, you must re-form the capacitors in the DC bus link circuit. Re-forming procedures are described in the Kollmorgen Developer Network ([Forming](#)).

NOTE

Additional information on setting up the equipment:

- Programming parameters and control loop behavior are described in the online help of the setup software.
- Kollmorgencan provide training courses for the drive upon request.

10.2 WorkBench Installation

This chapter describes the installation of the WorkBench software for AKD-C and AKD-N drives.

Kollmorgen offers training and familiarization courses on request.

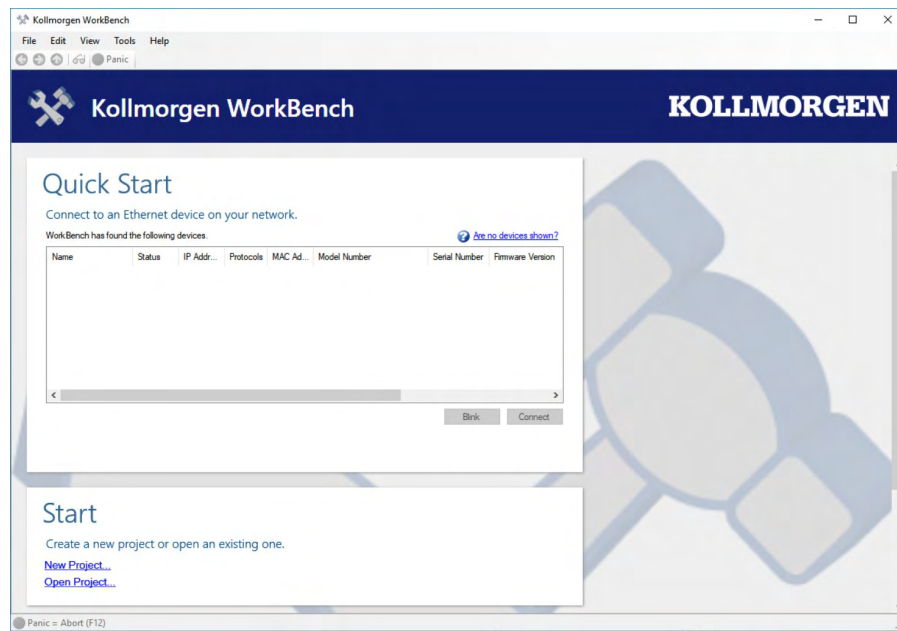

10.2.1 Use as directed

The setup software is intended to be used for altering and saving the operating parameters for the AKD series of products. The attached devices can be set up with the help of this software, and during this procedure the drive system can be controlled directly by the service functions.

Only professional personnel who have the relevant expertise (→ # 13) are permitted to carry out online parameter setting for a drive that is running. Sets of data that have been stored on data media are not safe against unintended alteration by other persons. Unexpected move could be the result if you use unchecked data. After loading a set of data you must therefore always check all parameters before enabling the drive.

10.2.2 Software description

Each device must be adapted to the requirements of your machine. For most applications, you can use a PC and WorkBench (the setup software) to set up the operating conditions and parameters. The PC is connected to the AKD-C by an Ethernet cable (→ # 82). The setup software provides the communication between the PC and every AKD-N drive connected to this AKD-C. You can find the setup software on the accompanying DVD and in the download area of the Kollmorgen website.

With very little effort you can alter parameters and instantly observe the effect on the drive, since there is a continuous (online) connection to the AKD-C. You can also read important actual values from drives, which are displayed on the monitor of the PC (oscilloscope functions).

You can save sets of data on data media (archiving) and load them into other AKD-C or use them for backup. You can also print out the data sets.

Most standard feedbacks (SFD, EnDAT 2.2, 2.1, and BiSS) are plug and play compatible. Motor nameplate data is stored in the feedback device and read by the drive automatically at startup. Non-plug and play Kollmorgen motors are stored in WorkBench and can be loaded with one-click using the Motor screen in the WorkBench software.

An extensive online help with integrated description of all variables and functions supports you in each situation.

10.2.3 Hardware requirements

The Service interface (X18, RJ45) is connected to the Ethernet interface of the PC by an Ethernet cable (→ # 82).

Minimum requirements for the PC:

Processor: at least 1 GHz

Operating system: Windows

Graphics adapter: Windows compatible, color

RAM: 500 MB

Data Drives: hard disk with at least 500 MB free space, DVD drive

Interface: one free Ethernet Interface, or a Switch port, 100 Mbit/s

10.2.4 Operating systems

Windows 2000 / XP / VISTA / 7 / 8

WorkBench works with Windows 2000, Windows XP, Windows VISTA, Windows 7 and Windows 8

Unix, Linux

The functioning of the software has not been tested for Windows running with Unix or Linux.

10.2.5 Installation under Windows

The DVD includes an installation program for the setup software.

Installation

- Autostart function activated:
Insert the DVD into a free data drive. A window with the start screen opens. There you find a link to the setup software WorkBench. Click it and follow the instructions.
- Autostart function deactivated:
Insert the DVD into a free data drive. Click **Start** (task bar), then **Run**. Enter the program call: x:\index.htm (x = correct DVD drive letter).
Click **OK** and proceed as described above.

Connection to the Ethernet interface of the PC

- Connect the interface cable to an Ethernet interface on your PC or to a Switch and to the service interface X18 of the AKD-C (→ # 82).

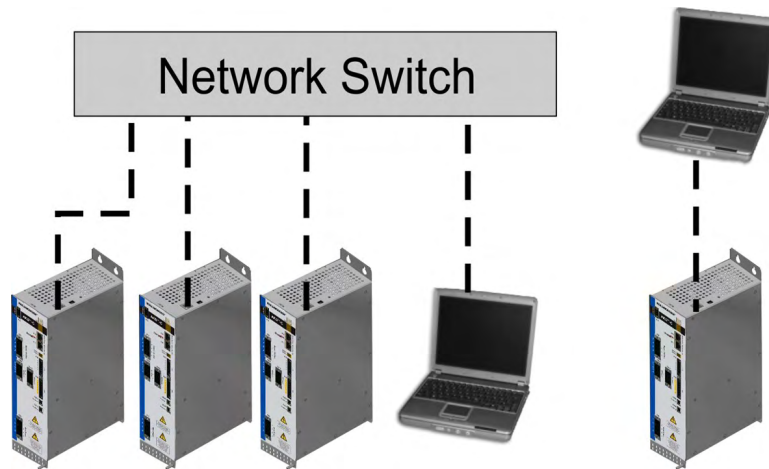

10.3 Initial System Test

10.3.1 Unpacking, mounting, and wiring

- Unpack the AKD-C and accessories. Observe the safety instructions in the documentation.
- Mount the AKD-C (→ # 49)ff.
- Connect the AKD-N via the hybrid cables to the AKD-C (→ # 53)ff.
- Connect motors to the connected AKD-N. See *AKD-N Installation Manual* for more information.
- Make sure you have on hand the following information about the drive components:
 - rated mains supply voltage
 - motor type (motor data, if the motor type is not listed in the motor database)
 - feedback unit built into the motor (type, poles/lines/protocol)
 - moment of inertia of the load
- Connect a PC with the installed WorkBench setup software to connector X18. See *AKD-C Installation Manual* for more information.

10.3.2 Set IP address

The AKD-C node address can be set with the rotary switch (→ # 83), with the WorkBench setup software or via the fieldbus.

10.3.3 Confirm connections

Switch on 24 VDC logic power for the system through the AKD-C X13 connector (mains supply voltage is not needed for communications).

Confirm that the green link LEDs on the AKD-C and on the PC are both illuminated.

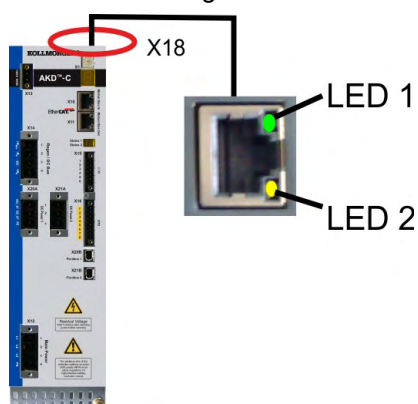

While the PC is connecting, your statusbar will show the following acquiring icon:

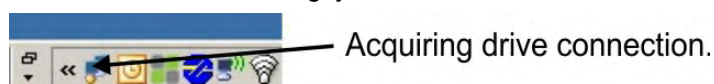

Wait for this icon to change to the limited functionality icon (this process can take up to one minute).

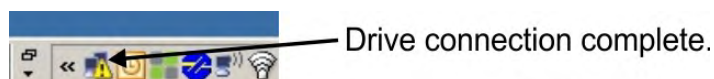

Although Windows displays this limited functionality icon for the drive connection, the PC can communicate fully with the drive. Using WorkBench, you can now configure the drive through this connection.

10.3.4 Install and start WorkBench

WorkBench installs automatically from the DVD included with the drive. WorkBench is also available on the Kollmorgen Web site: www.kollmorgen.com.

Once installation is complete, click the WorkBench icon to start the program. WorkBench will show a list of all the drives that it can find connected to the AKD-C.

Select the AKD-C you wish to configure and then click **Next**.

If multiple devices are detected, a device can be uniquely identified using one of the following methods:

1. The MAC address of the device. This address is printed on the sticker on the side of the drive.
2. The name of the devices. The device name is set using WorkBench. A new device defaults to "No_Name."
3. Blinking the display. Select a device and click **Blink** to force the display on the front of the drive to blink on and off for 20 seconds.

10.3.5 Enable the drive using the setup wizard

Once a connection to the AKD-C has been established, all AKD-N connected to this device are listed. Select one of these drives and the AKD Overview screen appears. Your drive appears in the navigation area on the left of the screen. Right click on your drive name and select **Setup Wizard** from the drop-down menu. The Setup Wizard guides you through the initial drive configuration, which includes a simple test motion.

After completing the Setup Wizard, your drive should be enabled. If the drive is not enabled, check the following:

1. The hardware enable (HW) for the drive strings must be in the enabled state (pin 3 on AKD-C X15 connector).
2. The software enable (SW) must be in the enabled state. Activate using the **Enable/Disable** button on the upper toolbar on WorkBench or in the Overview screen.
3. No faults may be present (click the **Clear Fault** button on the upper tool bar to clear any faults).

The status of HW enable, SW enable, and Faults is displayed in the lower toolbar of the WorkBench software. The drive is connected if the lower right corner shows **Online**.

You can now use the Settings View in WorkBench to complete advanced configuration of your drive.

10.4 Fault and Warning Messages

When a fault occurs, the AKD-C fault relay is opened, the output stage of the connected AKD-N are switched off (motors lose all torque), or the load is dynamically braked. The specific behavior depends on the type of fault. The LED display shows the number of the fault that occurred. If a warning is issued prior to the fault, the warning is shown on the LED and has the same number as the associated fault. Warnings do not trip the power stages of the connected AKD-N or fault relay output.

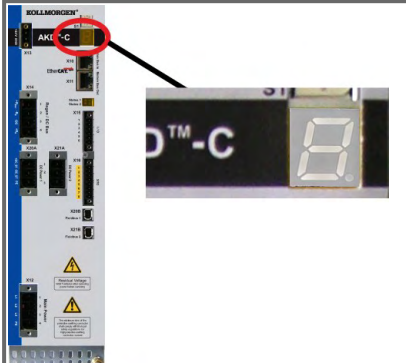

AKD fault codes or warning codes are displayed constantly if present. Fault messages are coded with "F", warnings are coded with "n".

The LED displays the fault or warning number as follows: F-1-0-1-[break] or n-1-0-1-[break]. The highest priority fault is displayed. Multiple faults may be present when a fault condition is occurring. Check the AKD WorkBench Fault Screen or read the status of DRV.FAULTS through the controller or HMI for the entire list of faults.

NOTICE

Eliminate errors and faults in compliance with work safety rules. Troubleshooting only by qualified and trained staff.

NOTE

More information about fault messages, causes, remedy and clearing faults can be found in the WorkBench online help.

Fault	Message/Warning
F0	Reserved.
F101	Firmware type mismatch.
n101	The FPGA is a laboratory FPGA.
F102	Resident firmware failed.
n102	Operational FPGA is not a default FPGA.
F103	Resident FPGA failed.
F104	Operational FPGA failed.
F105	Non-volatile memory stamp invalid.
F106	Non-volatile memory data.
F125, n125	Fieldbus synchronization frames lost.
F136	Firmware and FPGA versions are not compatible .
F201	Internal RAM failed.
F202	External RAM failed.
F203	Code integrity failed.
F204 to F232	EEPROM failure detected.
F234 to F237 n234 to n237	Temperature sensor high.
F240 to F243 n240 to n243	Temperature sensor low.
F501, n501	Bus over voltage.
F503, n503	Bus capacitor overload.
F519	Regen short circuit.
F521, n521	Regen over power.
F523	Bus over voltage FPGA.
F531	Power stage fault.
F536	Standby power supply fault.

Fault	Message/Warning
F537	Precharge fault.
F541	AC Input Phase L1 missing.
F542	AC Input Phase L2 missing.
F543	AC Input Phase L3 missing.
F545	String current over peak limit.
F546	String current over continuous limit.
F561	More than eight AKD-N connected to string 2.
F562	More than eight AKD-N connected to string 1.
F564	Number of connected AKD-N at string 1 decreased.
F565	Number of connected AKD-N at string 2 decreased.
F621	Control Board CRC fault.
F623	Power Board CRC fault.
F624	Power Board Watchdog fault.
F625	Power Board Communication fault.
F626	Power Board FPGA not configured.
F627	Control Board Watchdog fault.
F628	Data package on string 1 not received by AKD-C or AKD-N.
F629	Data package on string 2 not received by AKD-C.
F702, n702	Fieldbus communication lost.

10.5 Troubleshooting the AKD-C

Drive problems occur for a variety of reasons, depending on the conditions in your application. The causes of faults in multi-axis systems can be very complex. If you cannot resolve a fault, Kollmorgen customer support can give you further assistance.

NOTICE

Eliminate errors and faults in compliance with work safety rules. Troubleshooting only by qualified and trained staff.

NOTE

Details on the removal of faults can be found in the WorkBench online help.

--- / ---

11 Index

A

Abbreviations	11
AKD Family	29
Ambient Conditions	31
Ambient temperature	31
Aux. supply 24V, interface	67

C

Cable and Wire Requirements	33
Capacitor Modules	70
Conformance	
CE	22
EAC	24
REACH	24
RoHS	24
Safety	22
UL, cUL	23
Connection Diagram	64
Connection Overview	63
Connector Assignments	63
Connectors	33

D

DC bus link, interface	68
DC Power String, interface	76
Decommission	19
Digital inputs	78
Disassemble	19
Disposal	20
Document Revisions	96
Dynamic Braking	36

E

EAC	24
ENABLE	78
Enclosure protection	31
EtherCAT	81

F

Fault messages	91
FAULT relay	80
Fieldbus String, interface	76
Fusing	31

G

Global STO	39
grommets	74
Grounding	55

H

Humidity	
in operation	31
Storage	18
Transport	18

I

I/O-Connection	77
Initial Drive Test	89
Inputs	
Basic Data	32
Digital	78
Enable	78
STO	39

Installation

Electrical	53
Mechanical	50
Software WorkBench	88

Installation, Setup, Normal Operation	18
---	----

K

KCM	70
-----------	----

L

Leakage current	47
-----------------------	----

M

Mains supply, interface	66
Maintenance	19
Marquages UL	23
Mounting position	31

N

Nameplate	26
Noise Emission	31

O

Outputs

Basic Data	32
Digital	79
Fault Relay	80

P

Package supplied	26
Packaging	18
Part number scheme	27
PC connection	82
Pollution level	31
Prohibited Use	
General	16
STO	40
Pushbutton B1	83

R

Re-forming	18, 85
REACH	24
Regen circuit	36
Regen resistor, interface	69
Repair	20
Response Time STO	40
RoHS	24

S

Safe Torque Off (STO)	39
Safety Instructions	
General	12
STO	39
Service Interface	82
Setup	85
Setup Software	86
Shielding	55
Shock-hazard protection	47
Site altitude	31
slip ring	74
Stacking Height	
Storage	18
Transport	18
STO	39
STO Response Time	40
STO signals	80
Storage	18
Supply networks	65
Switch-on/switch-off behavior	37
Symbols used	10
System Grounding	57

T

Temperature	
in operation	31
Storage	18
Transport	18
Tightening torques, connectors	33
Transport	18
Trouble Shooting	92

U

UL Markings	23
Use as directed	
General	15
STO	40
WorkBench Setup Software	86

V

Ventilation	31
Vibrations	31

W

Warnings	91
Wiring	62
WorkBench	86
Hardware requirements	87
Installation	88
Operating systems	87

12 Record of Document Revisions

Revision	Remarks
A, 11/2013	First edition
B, 05/2014	KCM X4 and Ready contacts added, KCM switch-on sequence, STO section updated
C, 12/2014	Patents updated, typos corrected
D, 06/2015	STO certified, UL listed, EAC certified, connector voltage rating corrected, fusing suggestions completed, power connector voltage rating corrected, RoHS/REACH statements added, capacitor forming information added
E, 12/2015	KCM wiring corrected, notes for slip rings and IP67 grommets, static IP addressing removed, , "Package supplied" extended, Use as Directed (DC supply / grouping notes), KSM notes removed, output power in kVA, LVD 2014/35/EG, EMCD 2014/30/EG
F, 09/2016	Warning notes updated, Project Guide notes, warning labels described, UL Markings updated, circuit breaker removed from UL approval, mains frequency 40-70Hz, SCCR 42kA
G, 10/2017	Safety characteristic value MTTFd added, reference to safe slip rings (Stemmann)
H, 02/2018	Part number scheme (Mx types removed), Trademark list updated
J, 10/2018	Layout of the warning notes updated, , user expertise updated, new readers note cover page, wording AKD-N/IP67 environment note
K, 10/2019	RoHS, EAC, chapter used standards removed
L, 10/2021	RJ45: Unified notation, STO input current corrected, package supplied (Safety Notes), chapter System Grounding new, chapter "Shielding on drive" improved, chapter "Approvals" restructured, PFH values updated

--/--

About KOLLMORGEN

Kollmorgen is a leading provider of motion systems and components for machine builders. Through world-class knowledge in motion, industry-leading quality and deep expertise in linking and integrating standard and custom products, Kollmorgen delivers breakthrough solutions that are unmatched in performance, reliability and ease-of-use, giving machine builders an irrefutable marketplace advantage.



Join the [Kollmorgen Developer Network](#) for product support. Ask the community questions, search the knowledge base for answers, get downloads, and suggest improvements.

North America

KOLLMORGEN

201 West Rock Road
Radford, VA 24141, USA

Web: www.kollmorgen.com
Mail: support@kollmorgen.com
Tel.: +1 - 540 - 633 - 3545
Fax: +1 - 540 - 639 - 4162

Europe

KOLLMORGEN Europe GmbH

Pempelfurtstr. 1
40880 Ratingen, Germany

Web: www.kollmorgen.com
Mail: technik@kollmorgen.com
Tel.: +49 - 2102 - 9394 - 0
Fax: +49 - 2102 - 9394 - 3155

South America

KOLLMORGEN

Avenida João Paulo Ablas, 2970
Jardim da Glória, Cotia – SP
CEP 06711-250, Brazil

Web: www.kollmorgen.com
Mail: contato@kollmorgen.com
Tel.: +55 11 4615-6300

China and SEA

KOLLMORGEN

Room 302, Building 5, Lihpao Plaza,
88 Shenbin Road, Minhang District,
Shanghai, China.

Web: www.kollmorgen.cn
Mail: sales.china@kollmorgen.com
Tel.: +86 - 400 668 2802
Fax: +86 - 21 6248 5367