

Synchronous servomotors

AKM



Choose your Motor:

Typ	Flange	Standstill torque	Page
AKM1	40	0,18..0,41	⇒ 24
AKM2	58	0,48..1,42	⇒ 28
AKM3	70	1,15..2,88	⇒ 33
AKM4	84	1,95..6	⇒ 38
AKM5	108	4,7..14,4	⇒ 44
AKM6	138	11,9..25	⇒ 50
AKM7	188	29,4..53	⇒ 56

0 0,5 1 5 10 20 30 40 50 70 Nm

Already published editions

Edition	Comments
03 / 2004	First edition
12 / 2004	Performance curves corrected, polenumbers, gearhead mounts, several corrections
09 / 2005	centering AKM7, chapter 1, several corrections, BISS interface, protection class

Technical changes to improve the performance of the equipment may be made without prior notice!

Printed in the Federal Republic of Germany

All rights reserved. No part of this work may be reproduced in any form (by printing, photocopying, microfilm or any other method) or stored, processed, copied or distributed by electronic means without the written permission of Danaher Motion.

1	General	
1.1	About this manual	5
1.2	Use as directed	5
1.3	Symbols used in this manual:	5
1.4	Safety Notes	6
1.5	Important Notes	7
1.6	Design of the motors	8
1.7	General technical data	8
1.8	Standard features	9
1.8.1	Style	9
1.8.2	Shaft end, A-side	9
1.8.3	Flange	9
1.8.4	Protection class	9
1.8.5	Protective device	9
1.8.6	Insulation material class	9
1.8.7	Vibration class	10
1.8.8	Connection method	10
1.8.9	Feedback unit	10
1.8.10	Holding brake	10
1.8.11	Pole numbers	10
1.9	Options	11
1.10	Selection criteria	11
1.10.1	Model number description	12
1.10.2	Nameplate	12
2	Installation / Setup	
2.1	Important notes	13
2.2	Assembly / Wiring	14
2.2.1	Connection of the motors with preassembled cables	16
2.2.1.1	Wiring diagram for motors with resolver	17
2.2.1.2	Wiring diagram for motors with encoder	18
2.2.1.3	Wiring diagram for motors with SFD	19
2.2.1.4	Wiring diagram for motors with ComCoder	20
2.2.1.5	Wiring diagram for motors with BISS	21
2.3	Setup	22
3	Technical Data	
3.1	Definitions	23
3.2	AKM1	24
3.3	AKM2	28
3.4	AKM3	33
3.5	AKM4	38
3.6	AKM5	44
3.7	AKM6	50
3.8	AKM7	56
4	Appendix	
4.1	Assignment of RediMount gearhead mounts	61
4.2	Delivery package, transport, storage, maintenance, disposal	62
4.3	Removing faults	63
4.4	Index	64

Manufacturer declaration

According to the EG-Machine-guideline 98/37/EC, appendix II B

We, the company

Danaher Motion GmbH
Wacholderstrasse 40-42
40489 Düsseldorf

declare, that the product

Motor series AKM
(Types AKM1, AKM2, AKM3, AKM4, AKM5, AKM6, AKM7)

is intended exclusively, in its standard version, for installation in another machine and that its setup is forbidden until it has been established that the machine into which this product is to be installed conforms to the provisions of the EC Directive in its version 98/37/ECW.

We confirm that the above-mentioned product conforms to the following standards:

73/23/EEC	Low voltage directive
VDE 0530 / DIN 57530	Provisions for rotating machinery
DIN EN 60034-7	Design
DIN 748	Cylindrical shaft ends
DIN 6885	Keyway and Key
DIN 42955	True running, coaxiality and concentricity
DIN EN 60034-14	Vibration class

Issued by: Management

Michel van Roozendaal

This Declaration does not contain any assurance of properties. The notes on safety and protection in the operating instructions must always be observed.

1 General

1.1 About this manual

This manual describes the AKM series of synchronous servomotors (standard version). Among other things, you find information about:

- General description, standard version of the motors Chapter 1
- Installation, Setup, Wiring Chapter 2
- Technical data, dimensions and characteristics Chapter 3
- Notes on Transport, Storage, Maintenance, Disposal Chapter 4



This Manual is intended for the use of qualified staff with professional knowledge of electrical and mechanical engineering.

The motors are operated in drive systems together with servo amplifiers SERVOSTAR. Please observe the entire system documentation, consisting of:

- Installation and setup instructions for the servo amplifier
- Installation and setup instructions for any expansion card which is connected
- Operating manual for the Operator Software of the servo amplifier
- Technical description of the AKM series of motors

1.2 Use as directed

The AKM series of synchronous servomotors is designed especially for drives for industrial robots, machine tools, textile and packing machinery and similar with high requirements for dynamics.

The user is **only** permitted to operate the motors under the ambient conditions which are defined in this documentation.

The AKM series of motors is **exclusively** intended to be driven by servo amplifiers from the SERVOSTAR series under speed and / or torque control.



The motors are installed as components in electrical apparatus or machines and can only be commissioned and put into operation as integral components of such apparatus or machines.

The motors must never be connected directly to the mains supply.

The thermal contact which is integrated in the motor windings must be observed and evaluated.

The conformity of the servo-system to the standards mentioned in the manufacturers declaration on page 4 is only guaranteed when the components (servo amplifier, motor, cables etc.) that are used have been supplied by us.

1.3 Symbols used in this manual:

	Danger to personnel from electricity and its effects		General warning general instruction mechanical hazard
⇒	see page/chapter (cross reference)	●	special emphasis

1.4

Safety Notes



- Only properly qualified personnel are permitted to perform such tasks as transport, assembly, setup and maintenance. Properly qualified personnel are persons who are familiar with the transport, assembly, installation, setup and operation of motors, and who have the appropriate qualifications for their jobs. The qualified personnel must know and observe the following standards and regulations:
 - IEC 364 resp. CENELEC HD 384 or DIN VDE 0100
 - IEC-report 664 or DIN VDE 0110
 - national regulations for safety / accident prevention or BGV A3
- Read the available documentation before assembly and setup. Incorrect handling of the motors can result in injury and damage to persons and machinery. Keep strictly to the technical data and the information on the connection requirements (nameplate and documentation).
- The manufacturer of the machine must generate a hazard analysis for the machine, and take appropriate measures to ensure that unforeseen movements cannot cause injury or damage to any person or property.
- It is vital that you ensure that the motor housing is safely earthed to the PE(protective earth) busbar in the switch cabinet. Electrical safety is impossible without a low-resistance earth connection.
- Do not unplug any connectors during operation. This creates the danger of death, severe injury, or extensive material damage.
- Power connections may be live even when the motor is not rotating. Never disconnect the power connections of the motor while the equipment is energised. This can cause flashovers with resulting injuries to persons and damage to the contacts.
- After disconnecting the servo amplifier from the supply voltage, wait at least five minutes before touching any components which are normally live (e.g. contacts, screw connections) or opening any connections.
The capacitors in the servo amplifier can still carry a dangerous voltage up to five minutes after switching off the supply voltages. To be quite safe, measure the DC-link voltage and wait until the voltage has fallen below 40V.
- The surfaces of the motors can be very hot in operation, according to their protection category. The surface temperature can exceed 100°C. Measure the temperature, and wait until the motor has cooled down below 40°C before touching it.
- Remove any fitted key (if present) from the shaft before letting the motor run independently, to avoid the dangerous results of the key being thrown out by centrifugal forces.

1.5

Important Notes



- Servomotors are precision equipment. The flange and shaft are especially vulnerable during storage and assembly — so avoid brute force. Precision requires delicacy. It is important to use the locking thread which is provided to tighten up couplings, gear wheels or pulley wheels and warm up the drive components, where possible. Blows or the use of force will lead to damage to the bearings and the shaft.

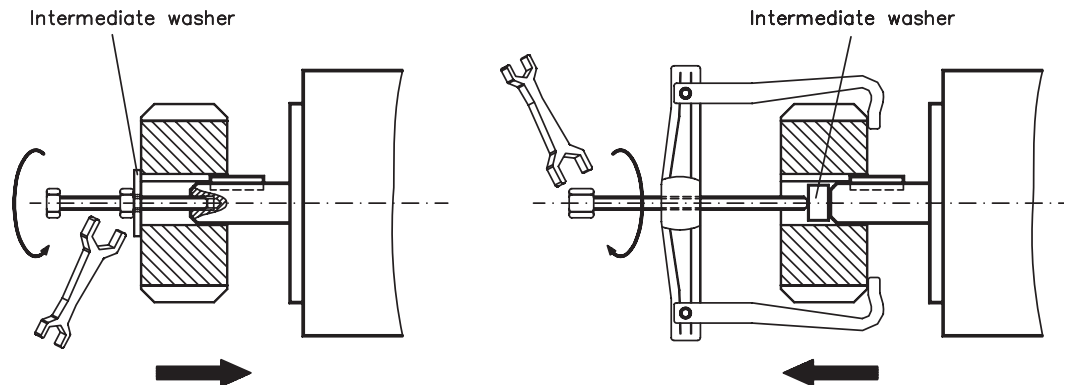

- Wherever possible, use only backlash-free, frictionally-locking collets or couplings. Ensure correct alignment of the couplings. A displacement will cause unacceptable vibration and the destruction of the bearings and the coupling.
- For toothed belts, it is vital to observe the permissible radial forces. An excessive radial load on the shaft will significantly shorten the life of the motor.
- Avoid axial loads on the motor shaft, as far as possible. Axial loading significantly shortens the life of the motor.
- In all cases, do not create a mechanically constrained motor shaft mounting by using a rigid coupling with additional external bearings (e.g. in a gearbox).
- For mounting style V3 (shaft end upwards), make sure that no liquid can enter the upper bearing.
- Take note of the no. of motor poles and the no. of resolver poles, and ensure that the correct setting is made in the servo amplifier which is used. An incorrect setting can lead to the destruction of the motor, especially with small motors.

1.6 Design of the motors

Synchronous servomotors in the AKM series are brushless DC motors for demanding servo applications. When combined with our digital servo amplifiers they are especially suited for positioning tasks in industrial robots, machine tools, transfer lines etc. With high requirements for dynamics and stability.

The servomotors have permanent magnets in the rotor. The rare earth neodymium -iron-boron magnetic material is an important factor in making it possible to drive these motors in a highly dynamic fashion. A three-phase winding which is driven by the servo amplifier is integrated into the stator. The motor does not have any brushes since commutation is performed electronically by the servo amplifier

The temperature of the winding is monitored by temperature sensors in the stator windings and is signalled via an electrically isolated thermistor (PTC, $\leq 550\Omega$ / $\geq 1330\Omega$).

A **resolver** is built into the motors as standard feedback element. The servo amplifiers in the SERVOSTAR series evaluate the resolver position and supply sinusoidal currents to the motors. The alternatively offered feedback systems partly cause a change of the motor length and cannot be retrofitted.

The motors can be delivered with or without a built-in holding brake. Retrofitting of the brake is not possible.

The motors are enamelled in matt black (RAL 9005). This finish is not resistant against solvents (e.g. trichlorethylene, nitro-thinners, or similar).

1.7 General technical data

Climate category	3K3 to EN 50178
Ambient temperature (at rated values)	5...+40°C for site altitude up to 1000m amsl It is vital to consult our applications department for ambient temperatures above 40°C and encapsulated mounting of the motors.
Permissible humidity (at rated values)	95% rel. humidity, no condensation
Power derating (currents and torques)	1% / K in range 40°C...50°C up to 1000m amsl for site altitude above 1000m amsl and 40°C 6% up to 2000m amsl 17% up to 3000m amsl 30% up to 4000m amsl 55% up to 5000m amsl No derating for site altitudes above 1000m amsl with temperature reduction of 10K / 1000m
Ball-bearing life	≥ 20.000 operating hours
Technical data	\Rightarrow p.23
Storage data	\Rightarrow p.62

1.8 Standard features

1.8.1 Style

The basic style for the AKM synchronous motors is style IM B5 according to DIN EN 60034-7. The permitted mounting positions may be read from the technical data of the motor series.

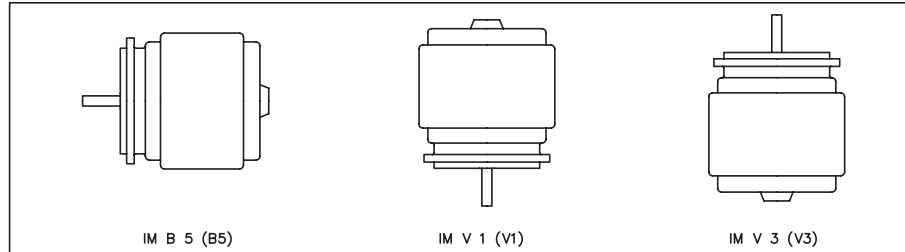

1.8.2 Shaft end, A-side

Power transmission is made through the cylindrical shaft end A, fit k6 (AKM1: h7) to DIN 748, with a locking thread but **without a fitted-keyway**.

If the motors drive via pinions or toothed belts, then high radial forces will occur. The permissible values at the end of the shaft may be read from the diagrams in chapter 3. The maximum values at rated speed you will find at the technical data. Power take-off from the middle of the free end of the shaft allows a 10% increase in F_R .

The curves are based on a bearing life of 20.000 operating hours.

The axial force F_A must not exceed $F_R/3$.

Double-coned collets have proved to be ideal zero-backlash coupling devices, combined, if required, with metal bellows couplings.

1.8.3 Flange

Flange dimensions to IEC standard, fit j6 (AKM1: h7), accuracy according to DIN 42955. Tolerance class: **N**

1.8.4 Protection class

Standard version	IP65
Standard shaft bushing	IP54
Shaft bushing with shaft-sealing ring	IP67

1.8.5 Protective device

The standard version of each motor is fitted with an electrically isolated PTC. The switching point is at $155^\circ\text{C} \pm 5\%$. The thermostat does **not** provide any protection against short, heavy overloading. Provided that our preassembled resolver cable is used, the thermostat contact is integrated into the monitoring system of the digital servo amplifier SERVOSTAR.

1.8.6 Insulation material class

The motors come up to insulation material class F according to DIN 57530.

1.8.7 Vibration class

The motors are made to vibration class N according to DIN EN 60034-14.

1.8.8 Connection method

The motors are equipped with angular connectors (AKM1/AKM2: straight connectors at cable ends) for power supply and feedback signals .

The mating connectors are not part of the delivery package. We can supply preassembled resolver and power cables. On page 16 you will find notes on the cable materials.

1.8.9 Feedback unit

Standard	Resolver	Two-pole hollow-shaft
Option	EnDat Encoder, Single-Turn	AKM2-AKM4: ECN 1113, : ECN1313
Option	EnDat Encoder, Multi-Turn	AKM2-AKM4: EQN 1125, AKM5-AKM7: EQN1325
Option	ComCoder	Incremental encoder with commutation, resolution 500-10000 lines
Option	SFD	fully digital resolver interface
Option	BiSS Encoder, Single-/Multi-Turn	AKM2-AKM4: AD36, AKM5-AKM7: AD58

The motor length depends on the mounted feedback unit. Retrofitting is not possible.

1.8.10 Holding brake

The motors are optionally available with a holding brake. A spring applied brake (24V DC) is integrated into the motors. When this brake is de-energized it blocks the rotor. **The holding brakes are designed as standstill brakes** and are not suited for repeated operational braking. If the brake is released then the rotor can be moved without a remanent torque. The motor length increases when a holding brake is mounted.

The holding brake can be controlled directly by SERVOSTAR-servo amplifier (no personal safety !), the winding is suppressed in the servo amplifier — additional circuitry is not required.

If the holding brake is not controlled directly by the servo amplifier, an additional wiring (e.g. varistor) is required. Consult our applications department beforehand.

A personal safe operation of the holding brake requires an additional contact (normally opened) in the braking circuit and an anti-surge-device (e.g. Varistor) for the brake.

Wiring example for SERVOSTAR 600

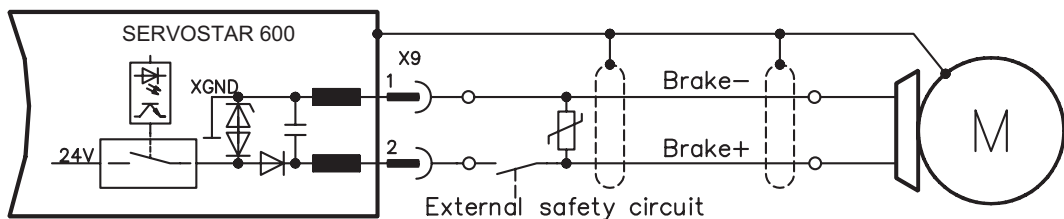

1.8.11 Pole numbers

Motor	Poles	Motor	Poles
AKM1	6	AKM5	10
AKM2	6	AKM6	10
AKM3	8	AKM7	10
AKM4	10		

1.9 Options

— Holding brake

Built-in holding brake.

Motor length increases by the holding brake.

— Radial shaft-sealing rings

A radial shaft-sealing ring can be supplied at extra charge to seal against oil mist and oil spray. This increases the protection rating of the shaft bushing to IP67.

— Keyway

The motors are available with keyway and key inserted according to DIN6885

The shaft is balanced with a short (half) key.

— EnDat, BISS, ComCoder, SFD

Another feedback system is mounted instead of the resolver. The motor length can increase by the alternative feedback.

With exception of the radial shaft seal the options **cannot** be retrofitted. Options such as radial shaft seal, holding brake, EnDat or Comcoder can lead to a reduction of rated data.

1.10 Selection criteria

The three-phase servomotors are designed to operate with SERVOSTAR servo amplifiers. Together, both units form a closed speed or torque control loop.

The most important selection criteria are:

—	Standstill torque	M_0	[Nm]
—	Rated speed	n_n	[min ⁻¹]
—	Moment of inertia of motor and load	J	[kgcm ²]
—	Effective torque (calculated)	M_{rms}	[Nm]

When calculating the motors and servo amplifiers which are required, take account of the static load **and** the dynamic load (acceleration/braking). Collected formulae and examples of the calculations are available from our applications department.

1.10.1 Model number description

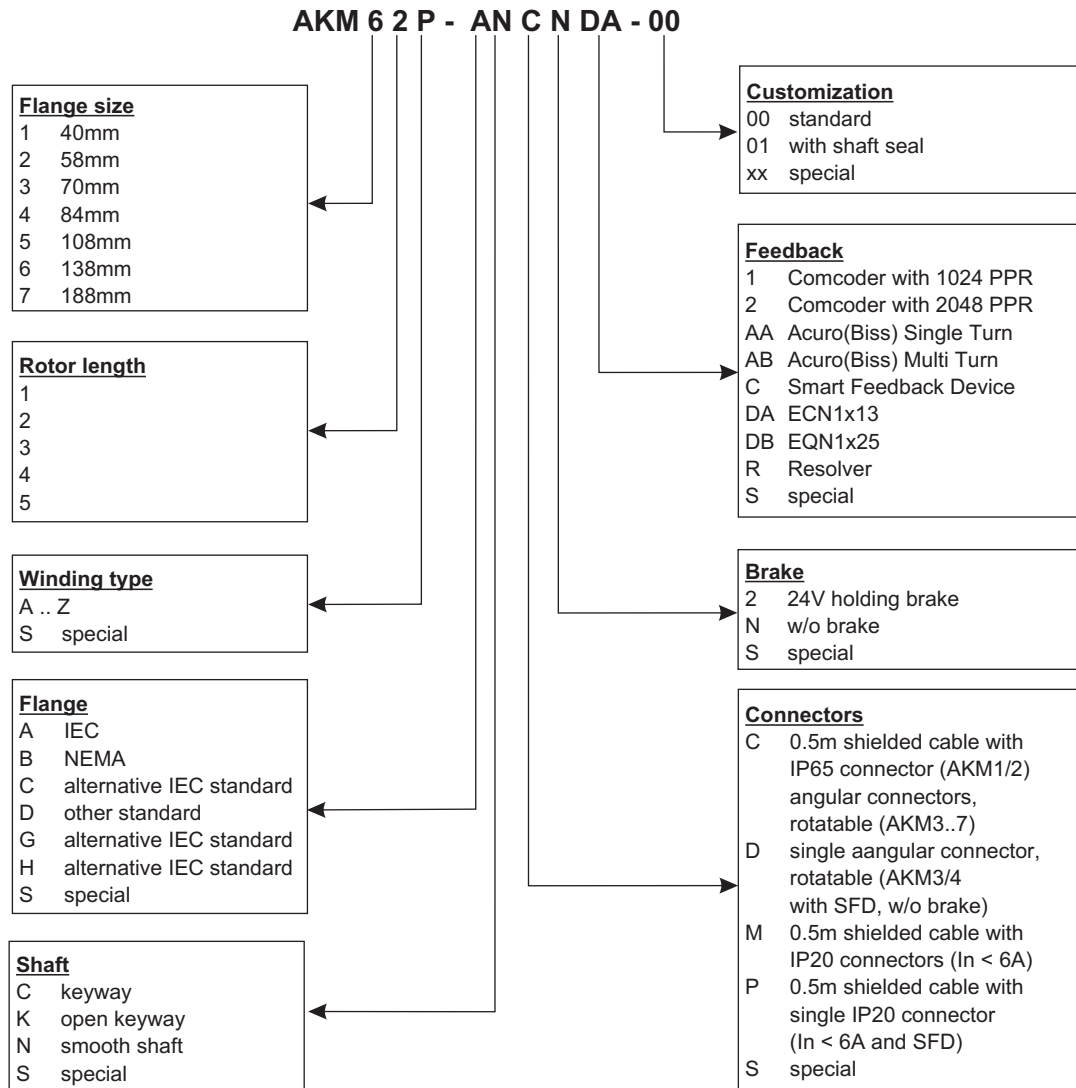

1.10.2 Nameplate

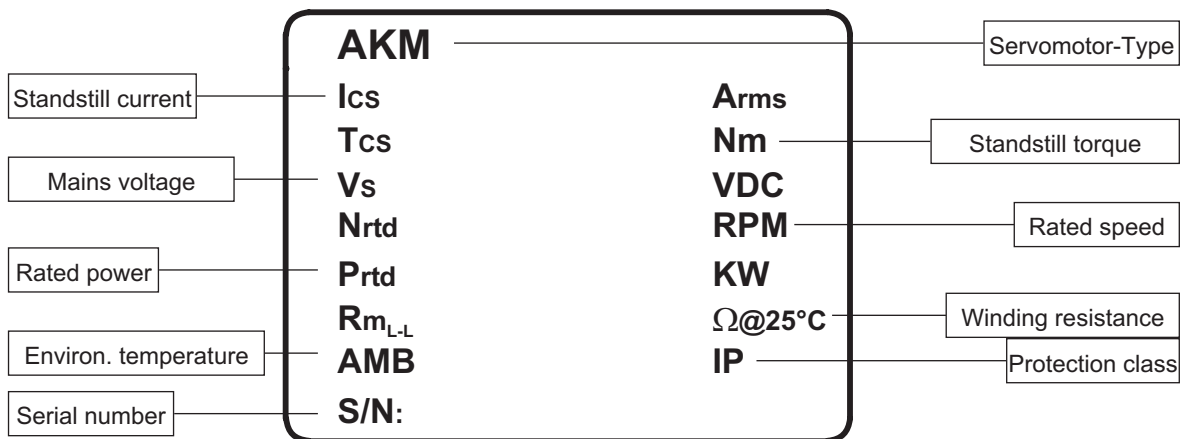

2 Installation / Setup

2.1 Important notes

- Check that the servo amplifier and motor match each other. Compare the rated voltage and rated current of the unit. Carry out the wiring according to the wiring diagram in the Installation and Setup Instructions for the servo amplifier. The connections to the motor are shown on pages 17f. Notes on the connection methods can be found on page 16.
- Ensure that there is proper earthing of the servo amplifier and the motor.
- Route the power and control cables as separately as possible from one another (separation > 20 cm). This will improve the immunity of the system to electromagnetic interference. If a motor power cable is used which includes integral brake control leads, then these brake control leads must be shielded. The shielding must be connected at both ends (see under Installation Instructions for the servo amplifier).
- Install all cables carrying a heavy current with an adequate cross-section, as per EN 60204. The recommended cross-section can be found in the Technical data.



Caution!

If a servo amplifier of the series SERVOSTAR is used and the motor cable exceeds 25m, a motor choke (type 3YLxxx) and motor leads with the following diameters must be used:

Rated output current of the servo amplifier	Maximum lead diameter of the motor cable (cable length > 25m and motor choke)
1...6 A	4 x 1mm ²
10...20 A	4 x 2,5mm ²

- Connect up all shielding via a wide surface-area contact (low impedance) and metallized connector housings or EMC-cable glands.
- Check the compliance to the permitted radial and axial forces F_R and F_A . When you use a toothed belt drive, the **minimal** permitted diameter of the pinion e.g. follows from the equation: $d_{\min} \geq \frac{M_0}{F_R} \times 2$.



Caution!

Never undo the electrical connections to the motor while it is energised. A dangerous voltage, resulting from residual charge, can be still present on the capacitors up to 5 minutes after switch-off of the mains supply.

Measure the DC-link voltage and wait until it has fallen below 40V.

Even when the motor is not rotating, control and power leads may be live.

2.2

Assembly / Wiring

Only qualified staff with knowledge of mechanical engineering are permitted to assemble the motor.

Only staff qualified and trained in electrical engineering are allowed to wire up the motor.

The procedure is described as an example. A different method may be appropriate or necessary, depending on the application of the equipment.

**Warning!**

Protect the motor from unacceptable stresses.

Take care, especially during transport and handling, that components are not bent and that insulation clearances are not altered.

Always make sure that the motors are de-energized during assembly and wiring, i.e. No voltage may be switched on for any piece of equipment which is to be connected.

Ensure that the switch cabinet remains turned off (barrier, warning signs etc.).

The individual voltages will only be turned on again during setup.

**Note!**

The ground symbol , which you will find in the wiring diagrams, indicates that you must provide an electrical connection, with as large a surface area as possible, between the unit indicated and the mounting plate in the switch cabinet. This connection is to suppress HF interference and must not be confused with the PE (protective earth) symbol (protective measure to EN 60204).

To wire up the motor, use the wiring diagrams in the Installation and Setup Instructions of the servo amplifier which is used.

The following notes should help you to carry out the assembly and wiring in an appropriate sequence, without overlooking anything.

Site	The site must be free of conductive and aggressive material. For V3-mounting (shaft end upwards), make sure that no liquids can enter the bearings. If an encapsulated assembly is required, please consult our applications department beforehand.
Ventilation	Ensure an unhindered ventilation of the motors and observe the permissible ambient and flange temperatures. For ambient temperatures above 40°C please consult our applications department beforehand.
Assembly	During assembly, take care that the motor is not overstressed when it is fixed in place.
Cable selection	Select cables according to EN 60204. See the table on page 13 when cable length exceeds 25m.
Earthing / Shielding	Use correct earthing and EMC-shielding according to the Installation instructions for the servo amplifier which is used. Earth the mounting plate and motor casing. For connection methods see chapter 2.2.1.
Wiring	<ul style="list-style-type: none">— Route power cables as separately as possible from control cables— Connect up the resolver or encoder.— Connect the motor cables, install motor chokes close to the servo amplifier, connect shields to shielding terminals or EMC connectors at both ends— Connect the holding brake, if used, Connect shielding at both ends.
Check	Final check of the installed wiring, according to the wiring diagram which was used

2.2.1

Connection of the motors with preassembled cables

- Carry out the wiring in accordance with the valid standards and regulations.
- Only use our preassembled shielded cables for the resolver and power connections.
- Connect up the shielding according to the wiring diagrams in the installation instructions for the servo amplifier.
- Incorrectly installed shielding inevitably causes EMC interference.

In the table below you find all cables supplied by us. Further information referring to chemical, mechanical and electrical qualities can be received from our applications department.

Insulating material

Sheathing PUR (Polyurethane, identification 11Y)
 core insulation PETP (Polyesterphthalate, identification 12Y)

Capacity

Motor cable less than 150 pF/m
 Resolver cable less than 120 pF/m

Technical Data

- All cables are UL-listed. The UL-Style-number is printed on the sheathing.
- All cables are suitable for trailing.
- Technical data refer to mobile usage of cables.
 Life time: 1 Million bending cycles
- The temperature range refers to the operation temperature.
- Identification:

N	=	numbered cores
F	=	cores with colour code according to DIN 47100
()	=	shielding

Cores [mm ²]	Identification	Temperature range [°C]	Cable diameter [mm]	Bending radius [mm]	Remarks
(4x1,0)	N	-30 / +80	10	100	Motor cable
(4x1,5)	N	-30 / +80	10,5	105	
(4x2,5)	N	-30 / +80	12,6	125	
(4x1,0+(2x0,75))	F	-30 / +80	10,5	100	Motor cable with integral brake control leads
(4x1,5+(2x0,75))	N	-30 / +80	11,5	120	
(4x2,5+(2x1))	F	-30 / +80	14,2	145	
(4x2x0,25)	F	-30 / +80	7,7	70	Resolver cable
(7x2x0,25)	F	-30 / +80	9,9	80	Encoder cable

2.2.1.1 Wiring diagram for motors with resolver

Top view
build-in plug
Resolver

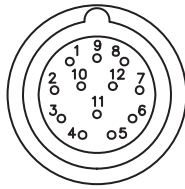

Top view
build-in plug
power

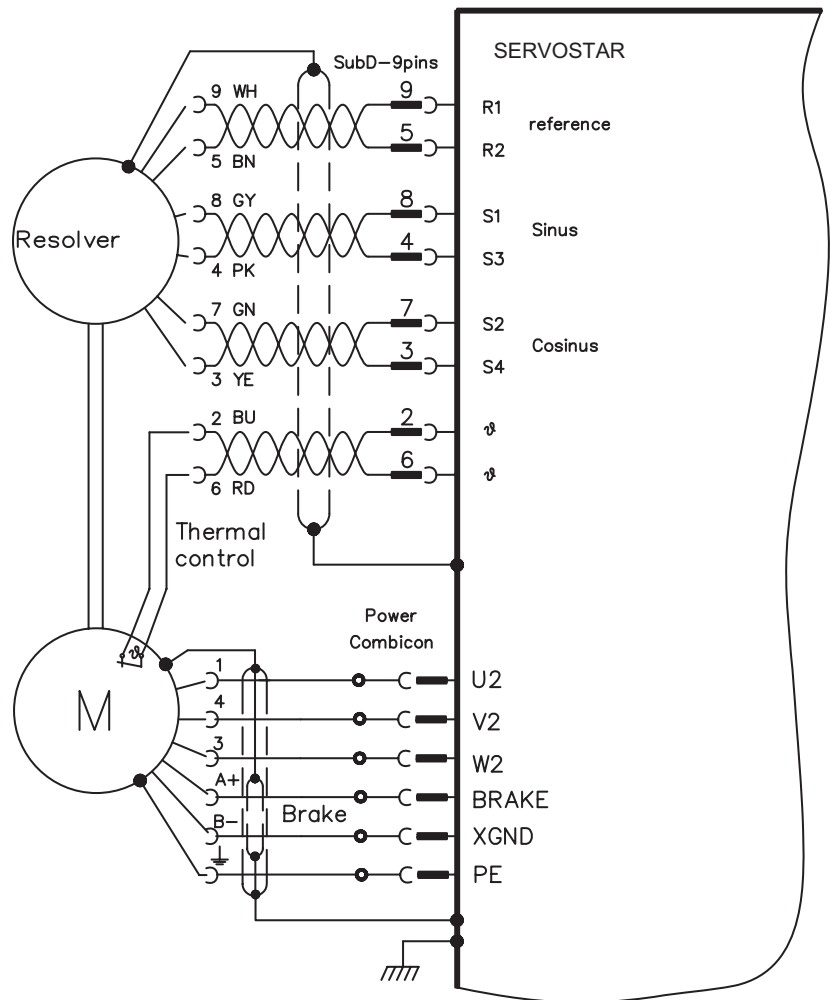
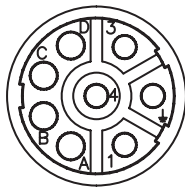

connector round, 12-poles

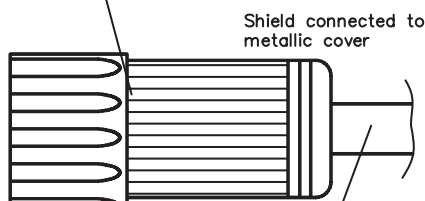

Shield connected to metallic cover

4 x 2 x 0,25
shielded, twisted pairs
on request max. 100m

Sub-D connector 9-poles

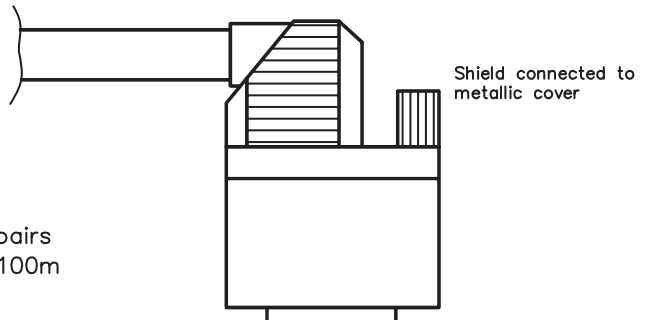

Shield connected to metallic cover

Colour coding acc. to IEC 757

2.2.1.2 Wiring diagram for motors with encoder

Top view
build-in plug
Encoder

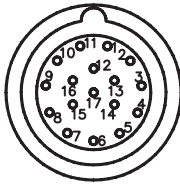

Top view
build-in plug
power

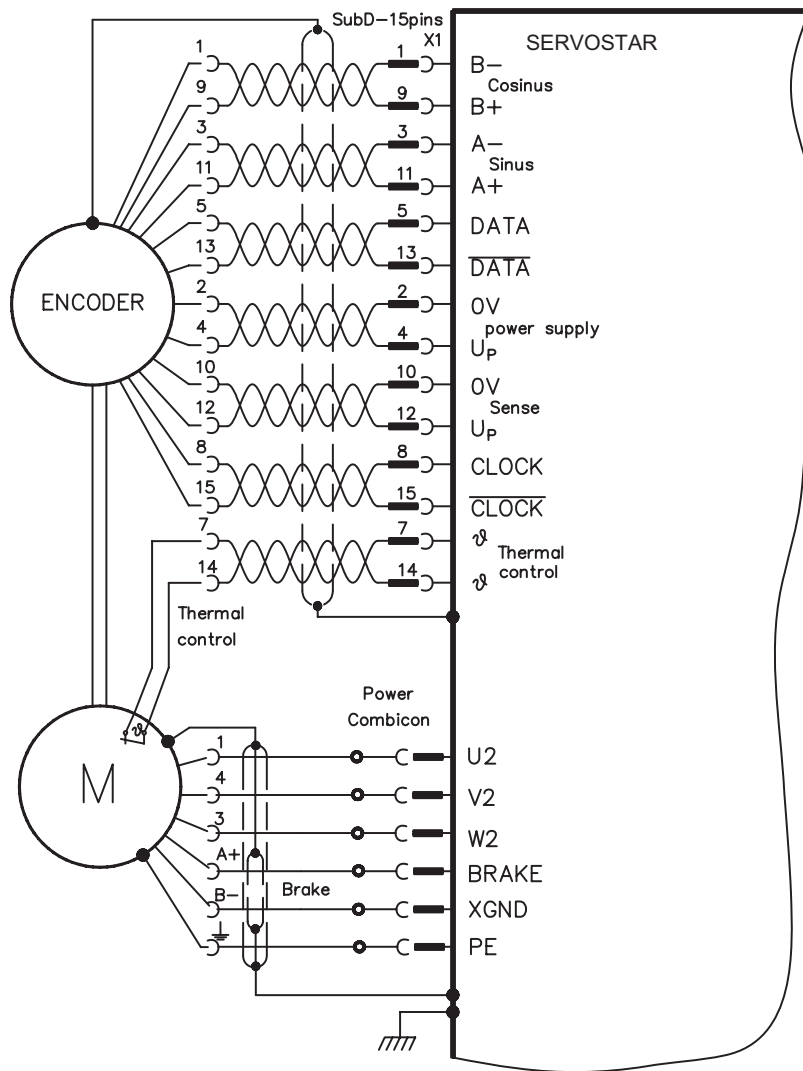
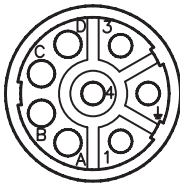

connector round, 17-poles

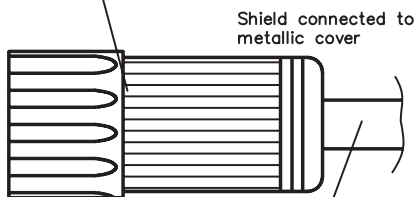

Shield connected to metallic cover

10 x 2 x 0,14 shielded, twisted pairs on request max. 50m

Sub-D connector 15-poles

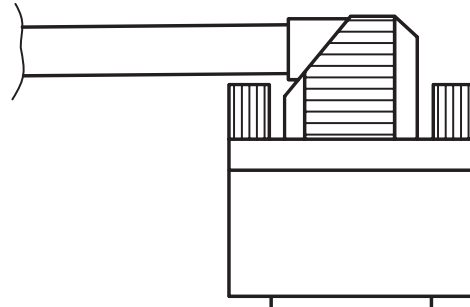

Shield connected to metallic cover

2.2.1.3 Wiring diagram for motors with SFD

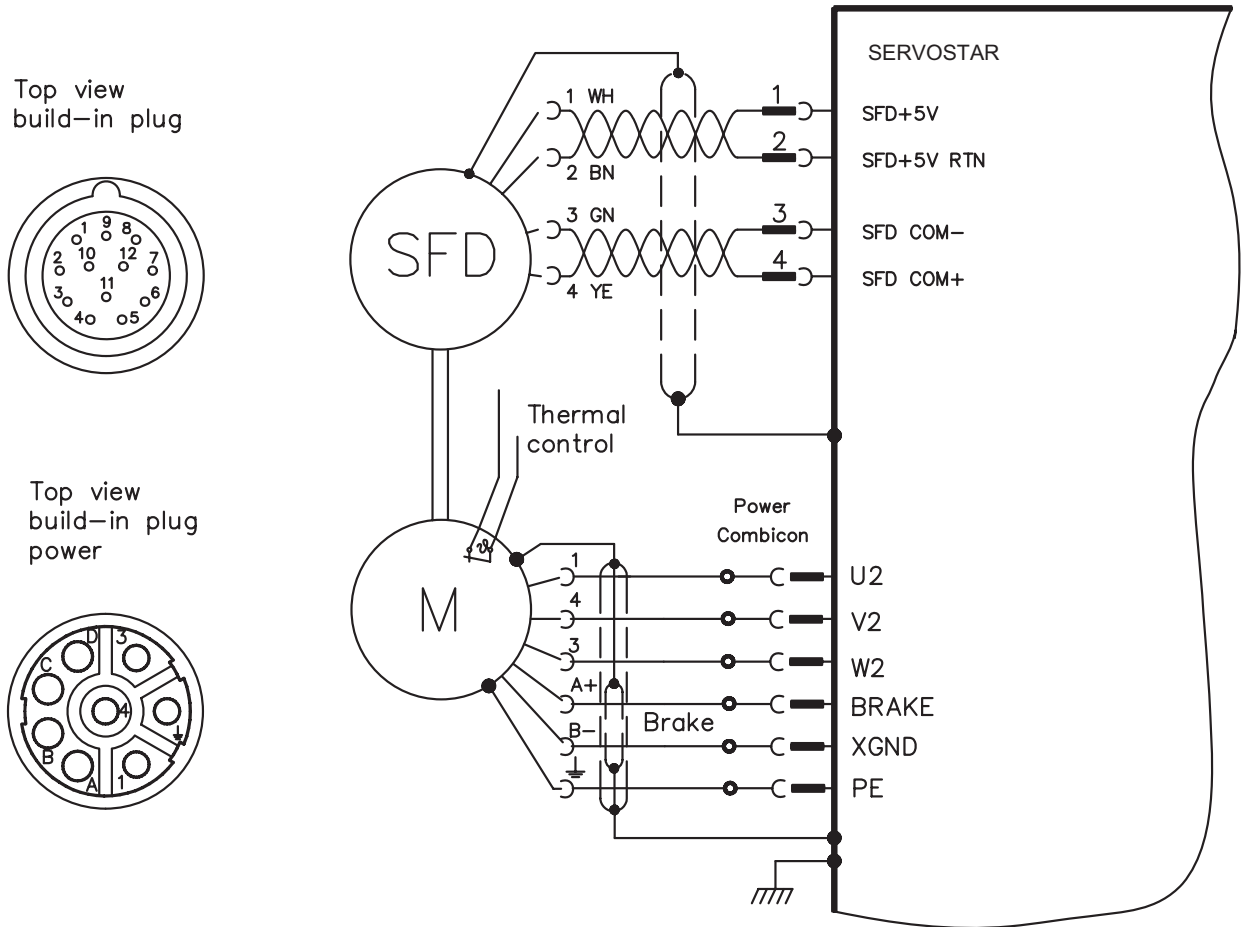

Colour coding acc. to IEC 757

2.2.1.4 Wiring diagram for motors with ComCoder

Top view
build-in plug
ComCoder

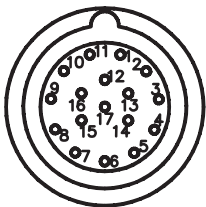

Top view
build-in plug
power

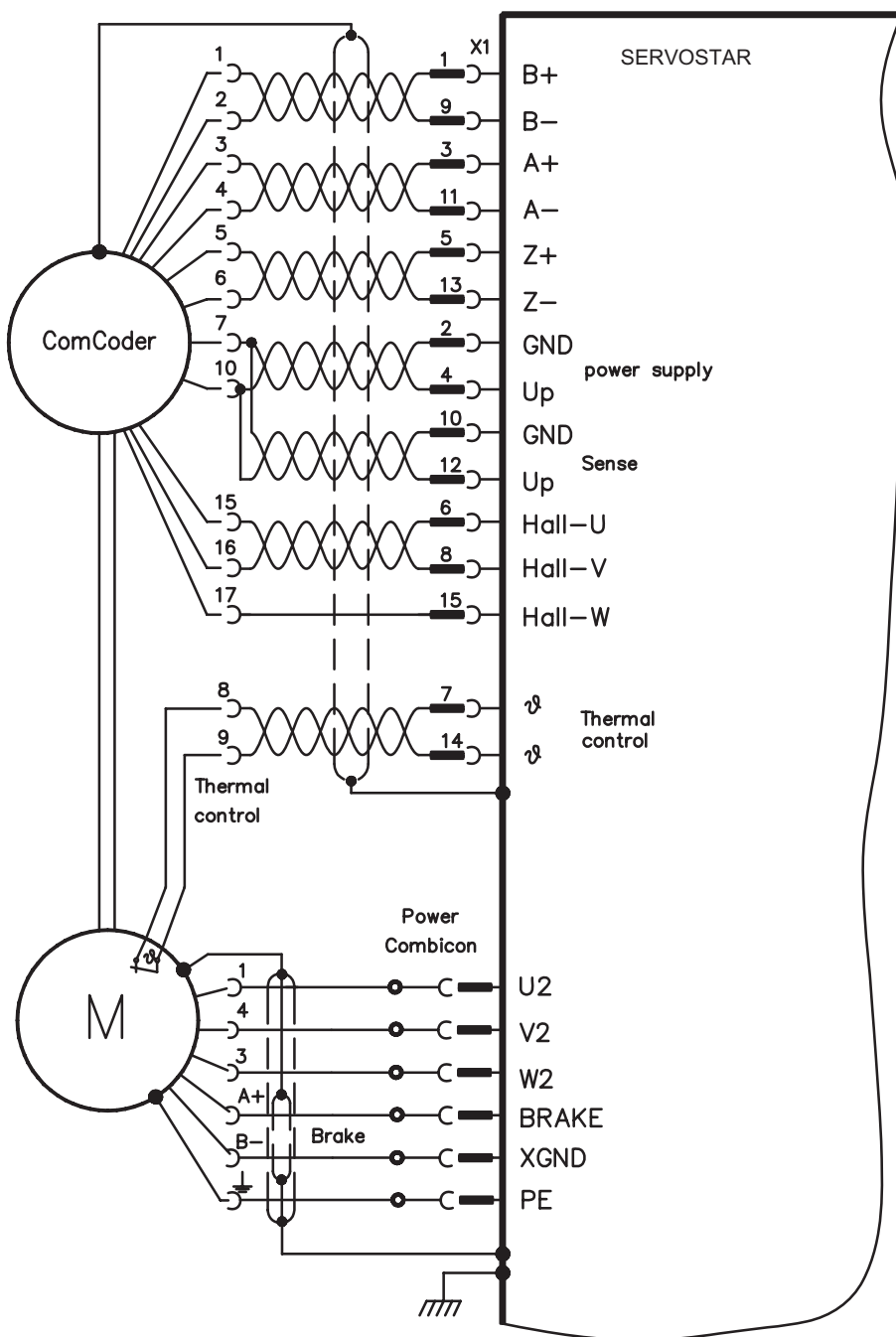
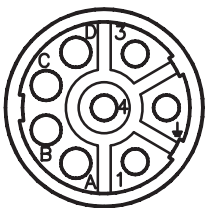

2.2.1.5 Wiring diagram for motors with BISS

Top view
build-in plug
Encoder

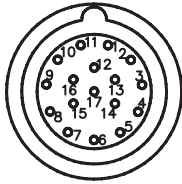

Top view
build-in plug
power

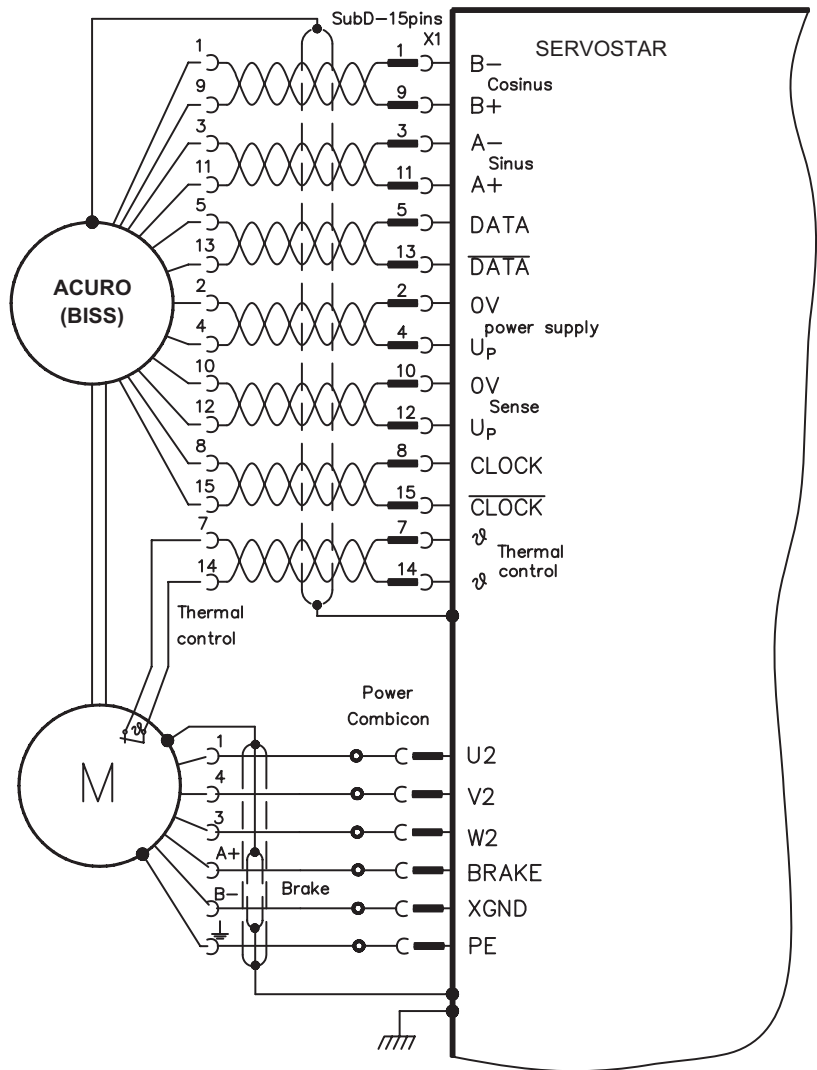
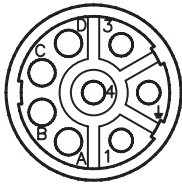

connector round, 17-poles

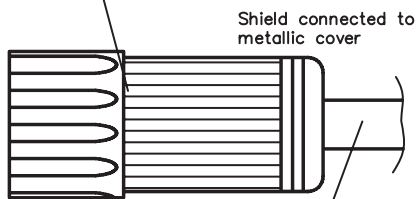

Shield connected to metallic cover

10 x 2 x 0,14
shielded, twisted pairs
on request max. 50m

Sub-D connector 15-poles

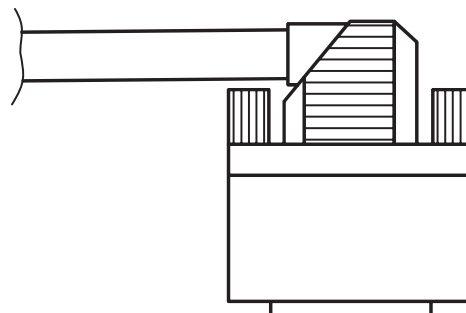

Shield connected to metallic cover

2.3 Setup

The procedure for setup is described as an example. A different method may be appropriate or necessary, depending on the application of the equipment.

Only specialist personnel with extensive knowledge in the areas of electrical engineering / drive technology are allowed to commission the drive unit of servo amplifier and motor.



Check that all live connection points (terminal boxes) are safe against accidental contact. Deadly voltages can occur, up to 900V.

Never undo the electrical connections to the motor when it is live. The residual charge in the capacitors of the servo amplifier can produce dangerous voltages up to 5 minutes after the mains supply has been switched off.

The surface temperature of the motor can exceed 100°C in operation.

Check (measure) the temperature of the motor. Wait until the motor has cooled down below 40°C before touching it.

Make sure that, even if the drive starts to move unintentionally, no danger can result for personnel or machinery.

- Check the assembly and orientation of the motor.
- Check the drive components (clutch, gear unit, belt pulley) for the correct seating and setting (observe the permissible radial and axial forces).
- Check the wiring and connections to the motor and the servo amplifier. Check that the earthing is correct.
- Test the function of the holding brake, if used. (apply 24V, the brake must be released).
- Check whether the rotor of the motor revolves freely (release the brake, if necessary). Listen out for grinding noises.
- Check that all the required measures against accidental contact with live and moving parts have been carried out.
- Carry out any further tests which are specifically required for your system.
- Now commission the drive according to the setup instructions for the servo amplifier.
- In multi-axis systems, individually commission each drive unit (servo amplifier and motor).

3 Technical Data

All data valid for 40°C environmental temperature and 100K overtemperature of the winding. The data can have a tolerance of +/- 10%. Example for a performance curve:

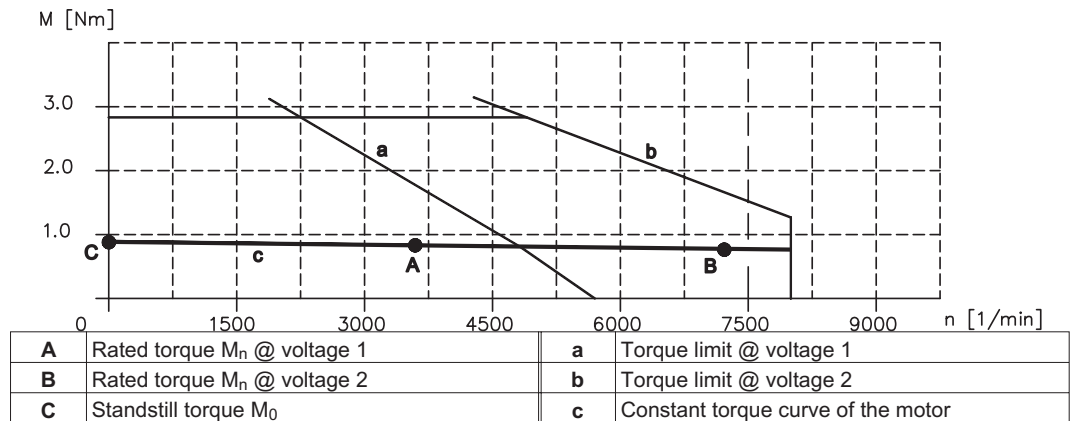

3.1 Definitions

Standstill torque M_0 [Nm]

The standstill torque can be maintained indefinitely at a speed $n < 100 \text{ min}^{-1}$ and rated ambient conditions.

Rated torque M_n [Nm]

The rated torque is produced when the motor is drawing the rated current at the rated speed. The rated torque can be produced indefinitely at the rated speed in continuous operation (S1).

Standstill current I_{0rms} [A]

The standstill current is the effective sinusoidal current which the motor draws at $n < 100 \text{ min}^{-1}$ to produce the standstill torque.

Peak current (pulse current) I_{0max} [A]

The peak current (effective sinusoidal value) is approximately equivalent to 4-times the rated current. The actual value is determined by the peak current of the servo amplifier which is used.

Torque constant K_{Trms} [Nm/A]

The torque constant defines how much torque in Nm is produced by the motor with 1A r.m.s. current. The relationship is $M = I \times K_T$ (up to $I = 2 \times I_0$)

Voltage constant K_{Erms} [mV/min⁻¹]

The voltage constant defines the induced motor EMF, as an effective sinusoidal value between two terminals, per 1000 rpm

Rotor moment of inertia J [kgcm²]

The constant J is a measure of the acceleration capability of the motor. For instance, at I_0 the acceleration time t_b from 0 to 3000 rpm is given as:

$$t_b [\text{s}] = \frac{3000 \times 2\pi}{M_0 \times 60\text{s}} \times \frac{m^2}{10^4 \times \text{cm}^2} \times J \quad \text{with } M_0 \text{ in Nm and } J \text{ in kgcm}^2$$

Thermal time constant t_{th} [min]

The constant t_{th} defines the time for the cold motor, under a load of I_0 , to heat up to an overtemperature of 0.63×10^5 Kelvin. This temperature rise happens in a much shorter time when the motor is loaded with the rated current.

Release delay time t_{BRH} [ms] / Application delay time t_{BRL} [ms] of the brake

These constants define the response times of the holding brake when operated with the rated voltage from the servo amplifier.

3.2

AKM1

Technical data

Data	Symbol [Unit]	AKM							
		11B	11C	11E	12C	12E	13C	13D	
Electrical data									
Standstill torque*	M_0 [Nm]	0,18	0,18	0,18	0,31	0,31	0,41	0,40	
Standstill current	I_{0rms} [A]	1,16	1,45	2,91	1,51	2,72	1,48	2,40	
max. Mains voltage	U_N [VAC]	230VAC							
$U = 75VDC$	Rated speed	n_n [min^{-1}]	—	—	6000	—	3000	—	2000
	Rated torque*	M_n [Nm]	—	—	0,18	—	0,31	—	0,40
	Rated power	P_n [kW]	—	—	0,11	—	0,10	—	0,08
$U_N = 115V$	Rated speed	n_n [min^{-1}]	4000	6000	—	4000	8000	3000	7000
	Rated torque*	M_n [Nm]	0,18	0,18	—	0,30	0,28	0,41	0,36
	Rated power	P_n [kW]	0,08	0,11	—	0,13	0,23	0,13	0,27
$U_N = 230V$	Rated speed	n_n [min^{-1}]	8000	—	—	8000	—	8000	—
	Rated torque*	M_n [Nm]	0,17	—	—	0,28	—	0,36	—
	Rated power	P_n [kW]	0,14	—	—	0,23	—	0,30	—
$U_N = 400V$	Rated speed	n_n [min^{-1}]	—	—	—	—	—	—	—
	Rated torque*	M_n [Nm]	—	—	—	—	—	—	—
	Rated power	P_n [kW]	—	—	—	—	—	—	—
$U_N = 480V$	Rated speed	n_n [min^{-1}]	—	—	—	—	—	—	—
	Rated torque*	M_n [Nm]	—	—	—	—	—	—	—
	Rated power	P_n [kW]	—	—	—	—	—	—	—
Peak current	I_{0max} [A]	4,65	5,79	11,6	6,06	10,9	5,93	9,6	
Peak torque	M_{0max} [Nm]	0,61	0,61	0,61	1,08	1,08	1,46	1,44	
Torque constant	K_{Trms} [Nm/A]	0,16	0,13	0,06	0,21	0,11	0,28	0,17	
Voltage constant	K_{Emms} [mV/min]	10,2	8,3	4,1	13,3	7,2	17,9	10,9	
Winding resistance Ph-Ph	R_{25} [Ω]	20,2	13,1	3,3	12,4	3,9	13,5	5,2	
Winding inductance Ph-Ph	L [mH]	12,5	8,3	2,0	9,1	2,7	10,3	3,8	
Mechanical data									
Rotor moment of inertia	J [kgcm ²]	0,017		0,031		0,045			
Pole number		6		6		6			
Static friction torque	M_R [Nm]	0,0011		0,0021		0,0031			
Thermal time constant	t_{TH} [min]	4		6		7			
Weight standard	G [kg]	0,35		0,49		0,63			
Radial load permitted at shaft end @ 8000 min ⁻¹	F_R [N]	30							
Axial load permitted at shaft end @ 8000 min ⁻¹	F_A [N]	12							

* reference flange Aluminium 254mm * 254mm * 6,35mm

Connections and cables

Data	AKM1
Power connection	4 + 4 poles, round, on Cable 0,5m
Motorcable, shielded	4 x 1
Motor cable with control leads, shielded	4 x 1 + 2 x 0,75
Resolver connection	12 poles, round, on Cable 0,5m
Resolver cable, shielded	4 x 2 x 0,25mm ²
Comcoder connection (option)	17 poles, round, on Cable 0,5m

Dimensions (drawing in principle)

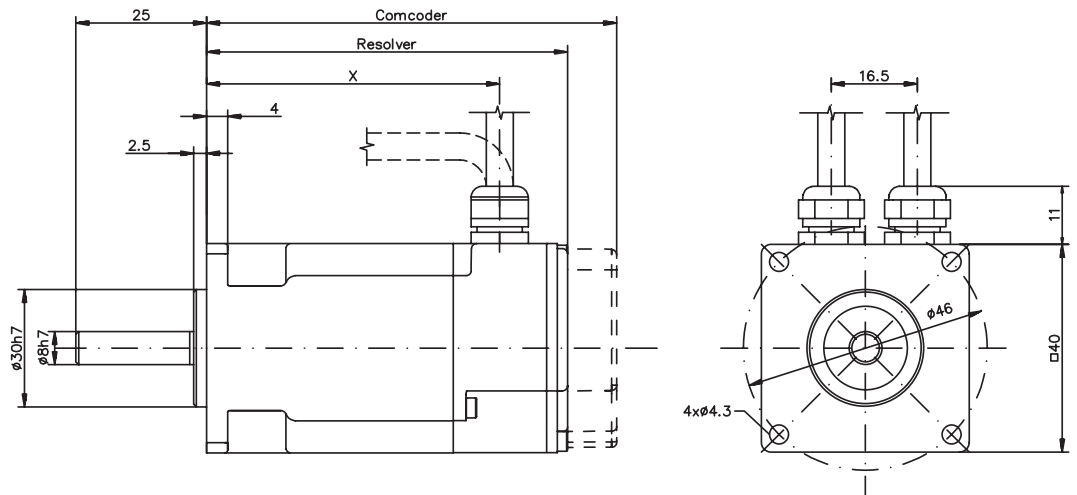

Model	X	Resolver	Comcoder
AKM11	56.1	69.6	79.0
AKM12	75.1	88.6	98.0
AKM13	94.1	107.6	117.0

Option Keyway

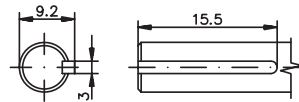

Radial/axial forces at the shaft end

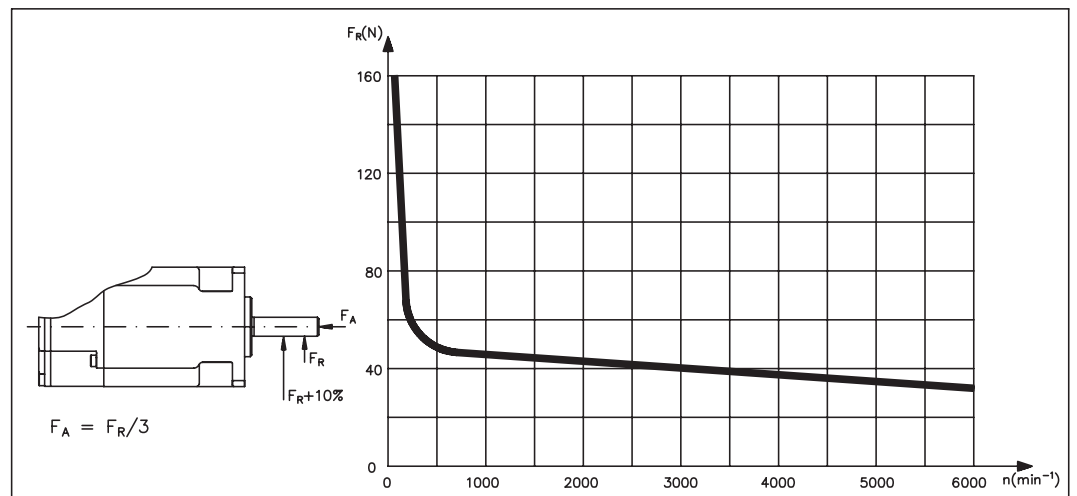

Performance curves

AKM11B

M [Nm]

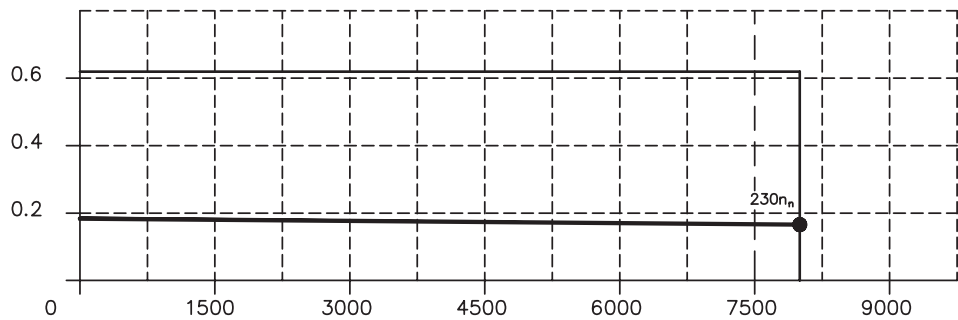

AKM11C

M [Nm]

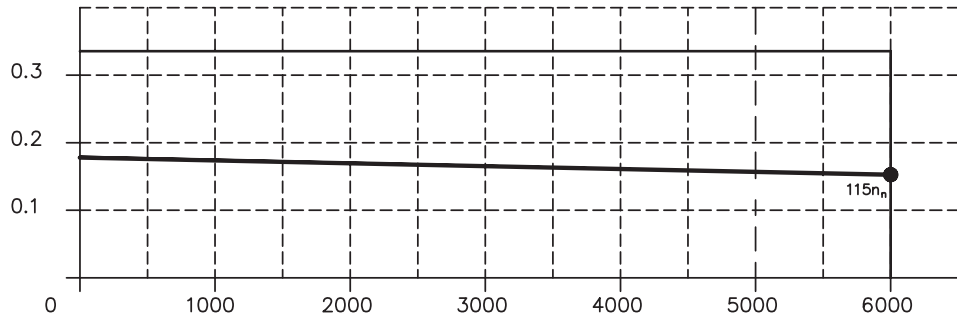

AKM11E

M [Nm]

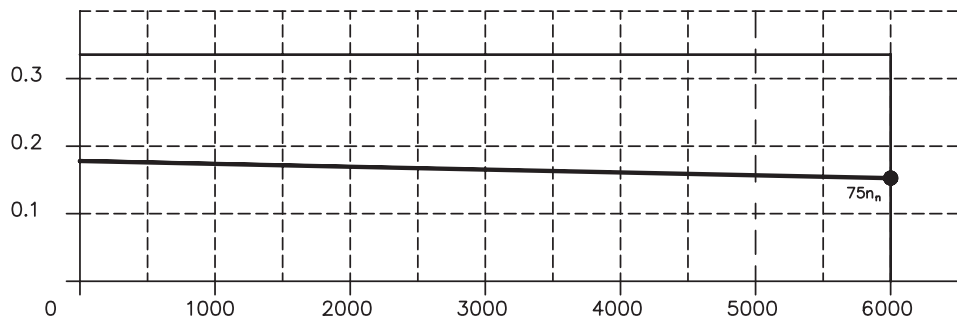

AKM12C

M [Nm]

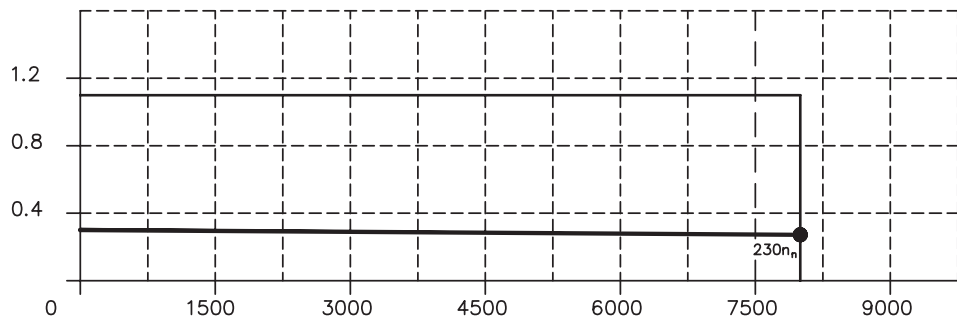

AKM12E

M [Nm]

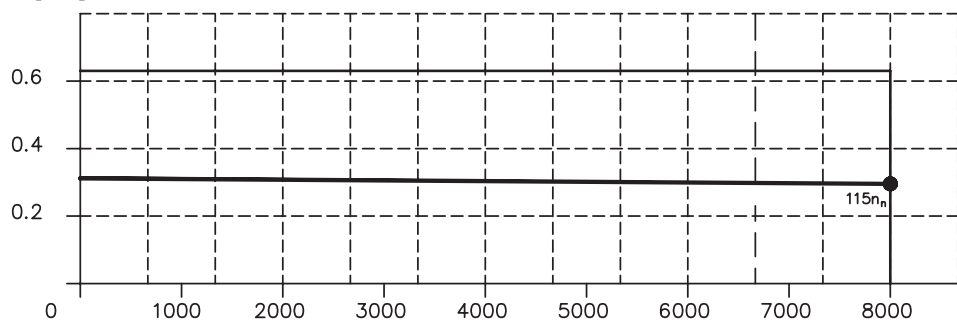

AKM13C

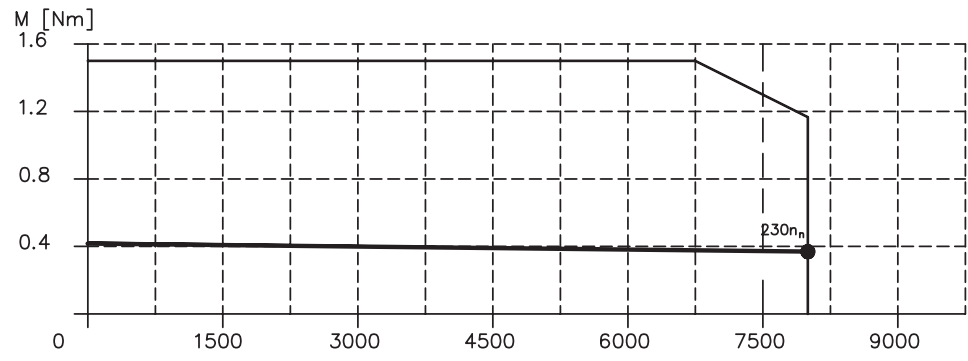

AKM13D

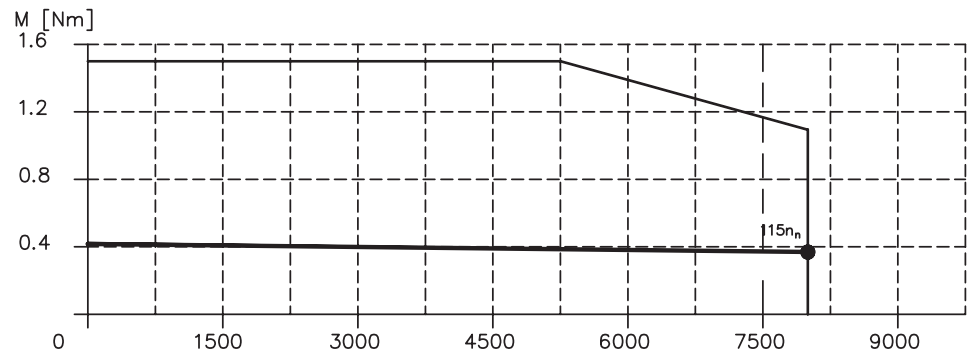

3.3

AKM2

Technical data

Data	Symbol [Unit]	AKM												
		21C	21E	21G	22C	22E	22G	23C	23D	23F	24C	24D	24F	
Electrical data														
Standstill torque*	M ₀ [Nm]	0,48	0,50	0,50	0,84	0,87	0,88	1,13	1,16	1,18	1,38	1,41	1,42	
Standstill current	I _{0rms} [A]	1,58	3,11	4,87	1,39	2,73	4,82	1,41	2,19	4,31	1,42	2,21	3,89	
max. Mains voltage	U _N [VAC]	480												
U = 75VDC	Rated speed	n _n [min ⁻¹]	—	2000	4000	—	1000	2500	—	—	1500	—	—	1000
	Rated torque*	M _n [Nm]	—	0,48	0,46	—	0,85	0,83	—	—	1,15	—	—	1,39
	Rated power	P _n [kW]	—	0,10	0,19	—	0,09	0,22	—	—	0,18	—	—	0,15
U _N = 115V	Rated speed	n _n [min ⁻¹]	2500	7000	—	1000	3500	7000	1000	1500	4500	—	1500	3000
	Rated torque*	M _n [Nm]	0,46	0,41	—	0,83	0,81	0,74	1,11	1,12	1,07	—	1,36	1,33
	Rated power	P _n [kW]	0,12	0,30	—	0,09	0,30	0,54	0,12	0,18	0,50	—	0,21	0,42
U _N = 230V	Rated speed	n _n [min ⁻¹]	8000	—	—	3500	8000	—	2500	5000	8000	2000	4000	8000
	Rated torque*	M _n [Nm]	0,39	—	—	0,78	0,70	—	1,08	1,03	0,94	1,32	1,29	1,12
	Rated power	P _n [kW]	0,32	—	—	0,29	0,59	—	0,28	0,54	0,79	0,28	0,54	0,94
U _N = 400V	Rated speed	n _n [min ⁻¹]	—	—	—	8000	—	—	5500	8000	—	4500	8000	—
	Rated torque*	M _n [Nm]	—	—	—	0,68	—	—	0,99	0,92	—	1,25	1,11	—
	Rated power	P _n [kW]	—	—	—	0,57	—	—	0,57	0,77	—	0,59	0,93	—
U _N = 480V	Rated speed	n _n [min ⁻¹]	—	—	—	8000	—	—	7000	8000	—	5500	8000	—
	Rated torque*	M _n [Nm]	—	—	—	0,68	—	—	0,95	0,92	—	1,22	1,11	—
	Rated power	P _n [kW]	—	—	—	0,57	—	—	0,70	0,77	—	0,70	0,93	—
Peak current	I _{0max} [A]	6,3	12,4	19,5	5,6	10,9	19,3	5,6	8,8	17,2	5,7	8,8	15,6	
Peak torque	M _{0max} [Nm]	1,47	1,49	1,51	2,73	2,76	2,79	3,77	3,84	3,88	4,73	4,76	4,82	
Torque constant	K _{Trms} [Nm/A]	0,30	0,16	0,10	0,61	0,32	0,18	0,80	0,52	0,27	0,97	0,63	0,36	
Voltage constant	K _{Erms} [mV/min]	19,5	10,2	6,6	39	20,4	11,7	51,8	33,8	17,6	62,4	40,8	23,4	
Winding resistance Ph-Ph	R ₂₅ [Ω]	13,0	3,42	1,44	19,4	5,09	1,69	20,3	8,36	2,23	20,4	8,4	2,77	
Winding inductance Ph-Ph	L [mH]	19	5,2	2,18	35,5	9,7	3,19	40,7	17,3	4,68	43,8	18,7	6,16	
Mechanical data														
Rotor moment of inertia	J [kgcm ²]	0,11		0,16		0,22		0,27						
Pole number		6		6		6		6						
Static friction torque	M _R [Nm]	0,002		0,005		0,007		0,01						
Thermal time constant	t _{TH} [min]	8		9		10		11						
Weight standard	G [kg]	0,82		1,1		1,38		1,66						
Radial load permitted at shaft end @ 5000 min ⁻¹	F _R [N]	145												
Axial load permitted at shaft end @ 5000 min ⁻¹	F _A [N]	60												

* reference flange Aluminium 254mm * 254mm * 6,35mm

Brake data

Data	Symbol [Unit]	Value
Holding torque @ 120°C	M _{BR} [Nm]	1,42
Operating voltage	U _{BR} [VDC]	24 ± 10 %
electrical power	P _{BR} [W]	8,4
Moment of inertia	J _{BR} [kgcm ²]	0,011
Release delay time	t _{BRH} [ms]	20
Application delay time	t _{BRL} [ms]	18
Weight of the brake	G _{BR} [kg]	0,27
Typical backlash	[°mech.]	0,46

Connections and cables

Data	AKM2
Power connection	4 + 4 poles, round, on Cable 0,5m
Motorcable, shielded	4 x 1
Motor cable with control leads, shielded	4 x 1 + 2 x 0,75
Resolver connection	12 poles, round, on Cable 0,5m
Resolver cable, shielded	4 x 2 x 0,25mm ²
Encoder connection (option)	17 poles, round, on Cable 0,5m
Encoder cable, shielded	7 x 2 x 0,25mm ²

Dimensions (drawing in principle)

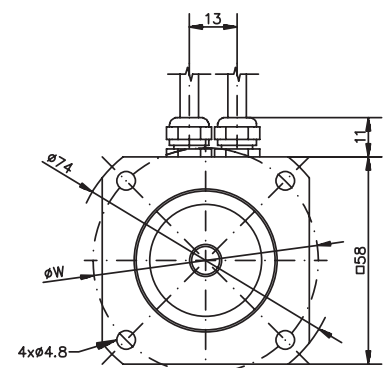
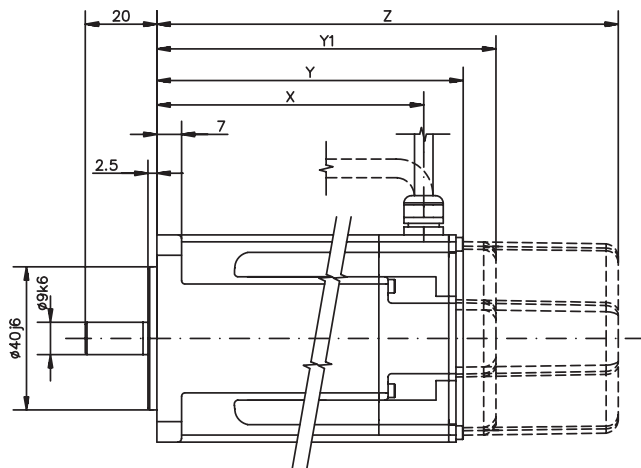

φW = φ63mm, AKM2xx-Ax
 φW = φ65mm, AKM2xx-Dx

Model	X	Resolver		Encoder	
		Y	Z (brake)	Y1	Z (brake)
AKM21	74.6	86.2	129.5	95.4	129.5
AKM22	93.6	105.2	148.5	114.4	148.5
AKM23	112.6	124.2	167.5	133.4	167.5
AKM24	131.6	143.2	186.5	152.4	186.5

Option Keyway

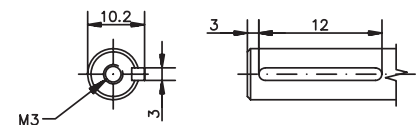

Radial-/axial forces at the shaft end

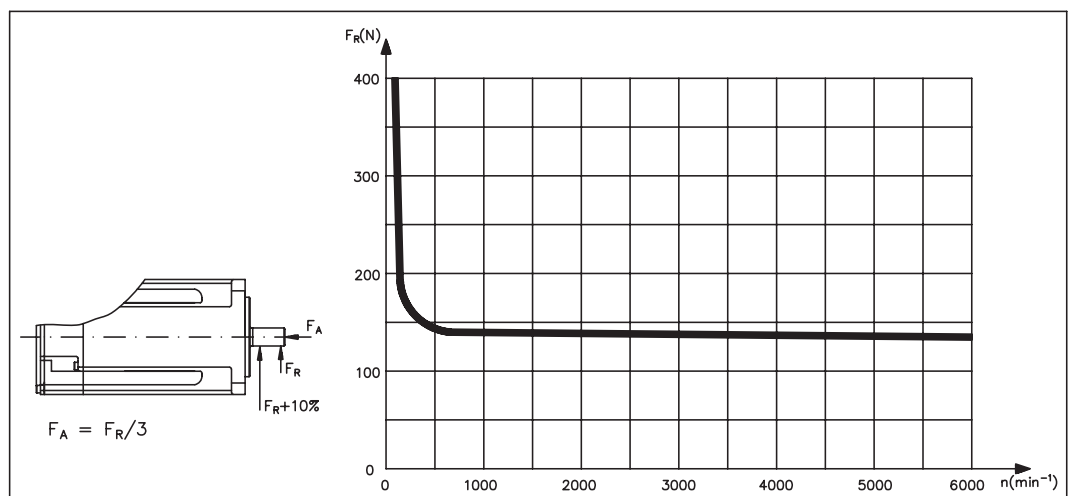

Performance curves

AKM21C

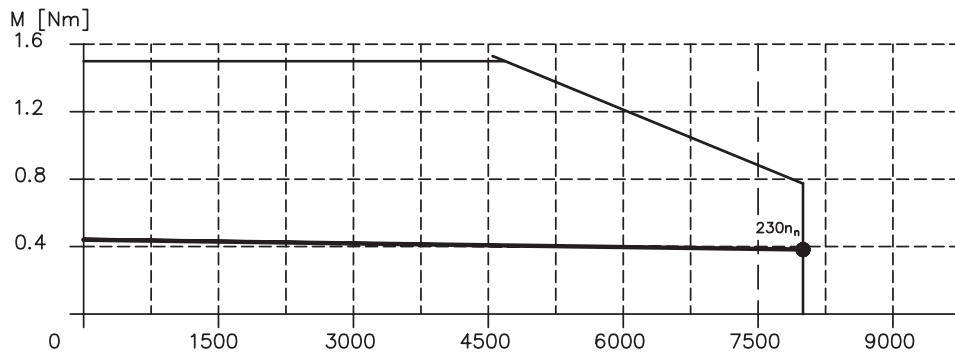

AKM21E

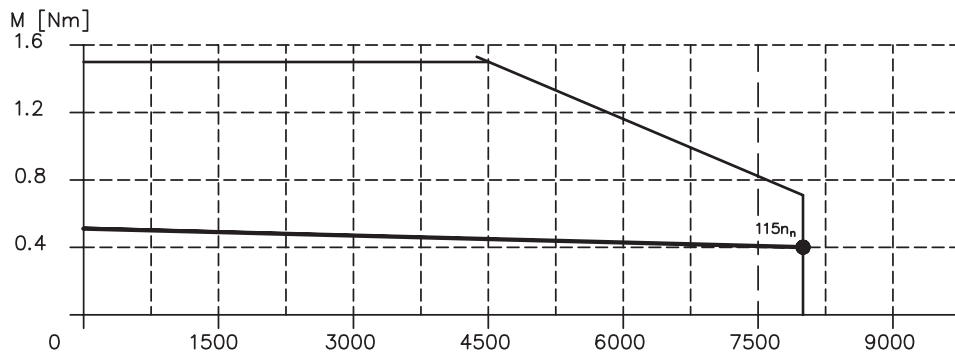

AKM21G

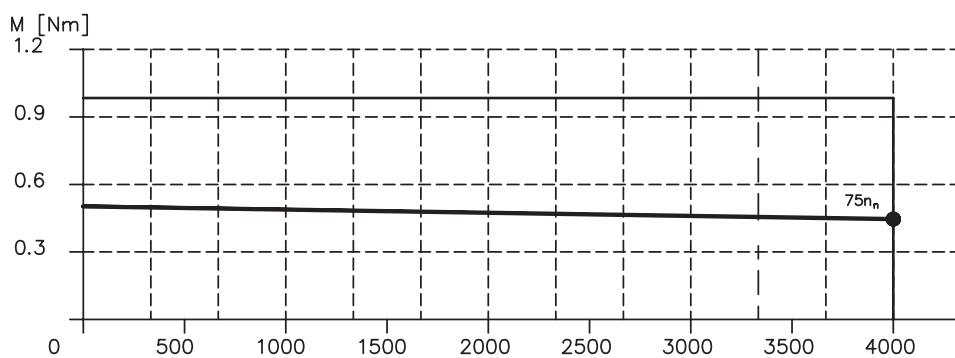

AKM22C

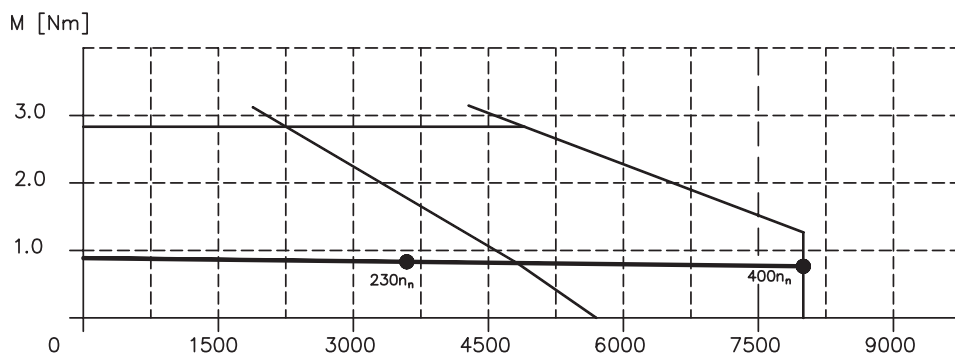

AKM22E

M [Nm]

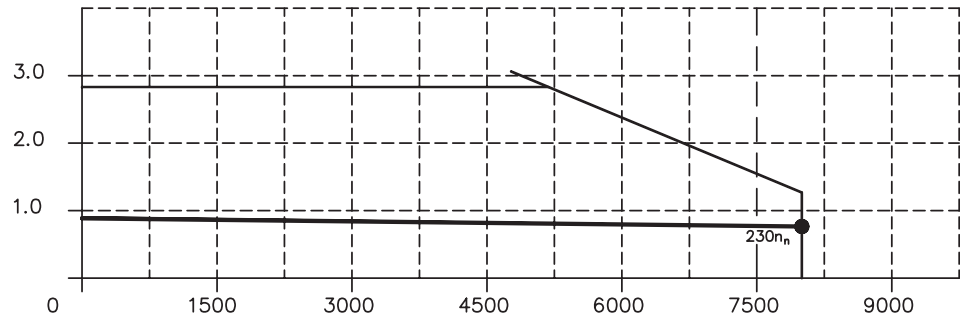

AKM22G

M [Nm]

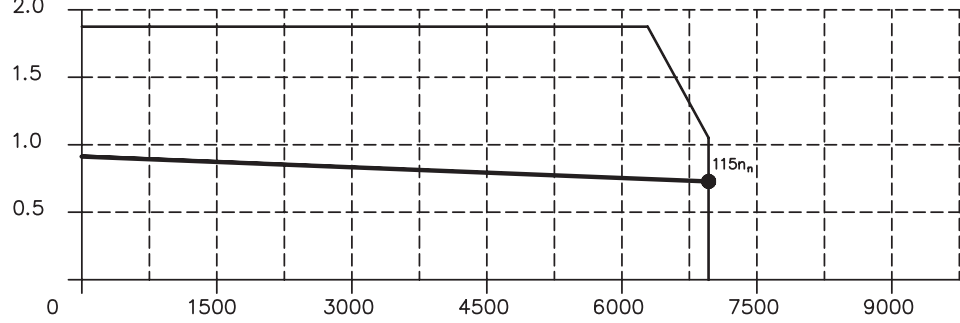

AKM23C

M [Nm]

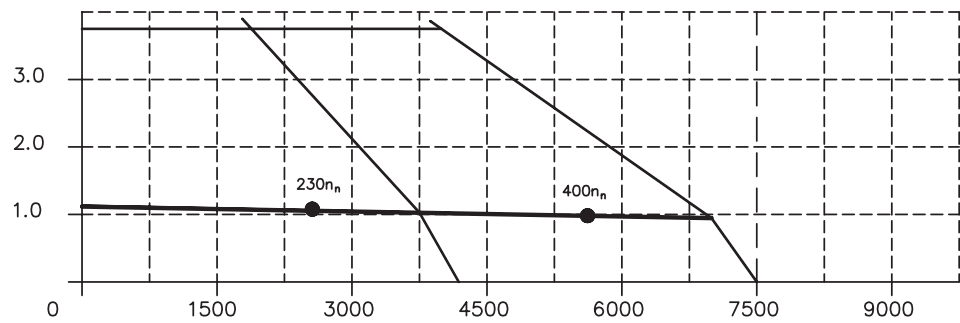

AKM23D

M [Nm]

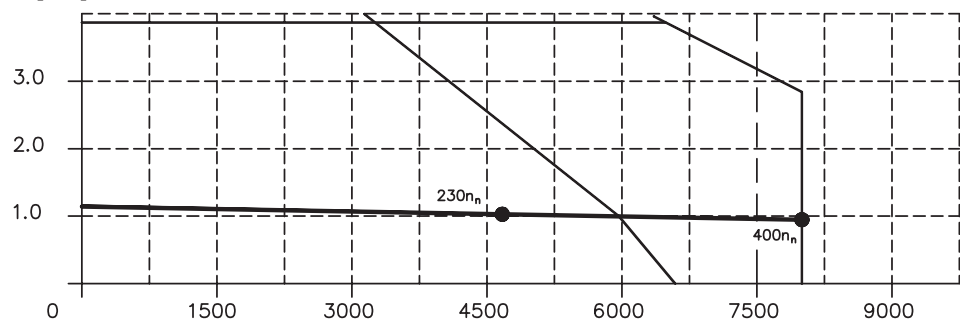

AKM23F

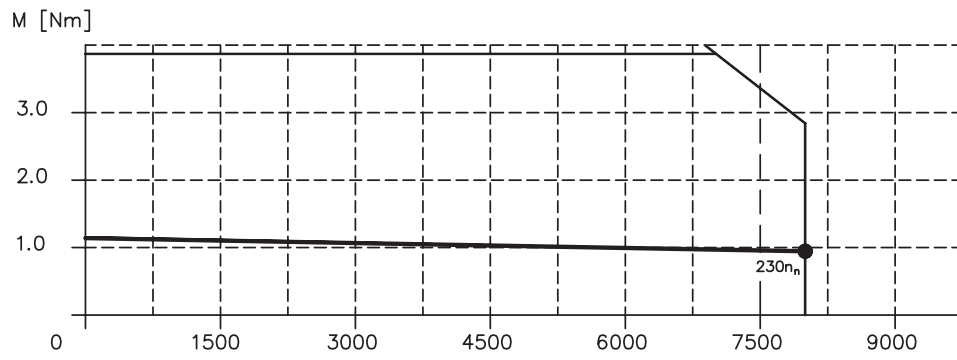

AKM24C

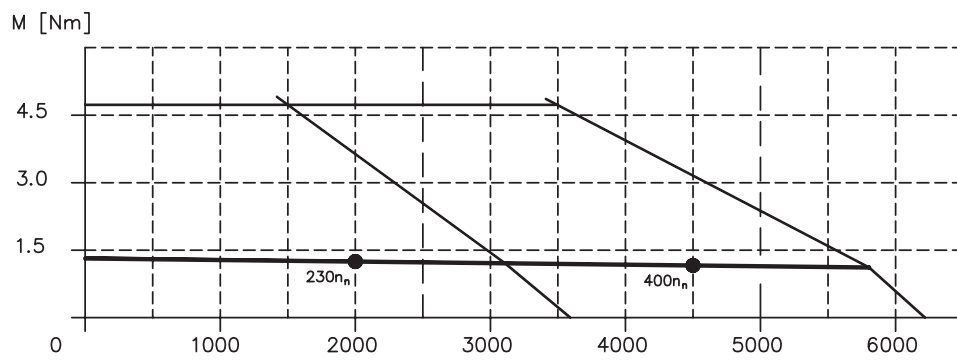

AKM24D

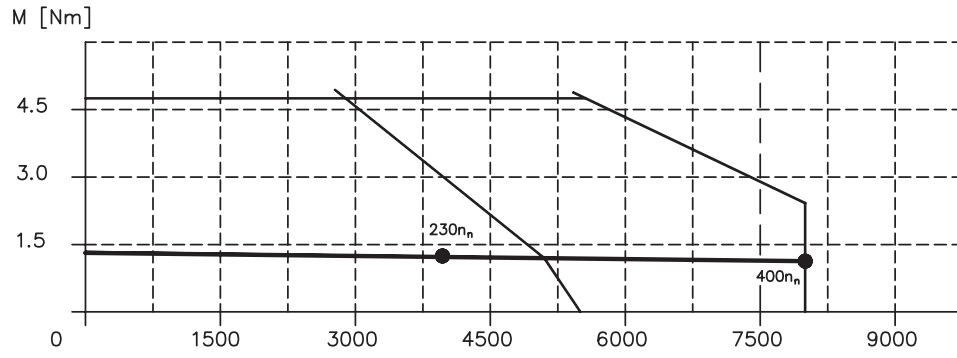

AKM24F

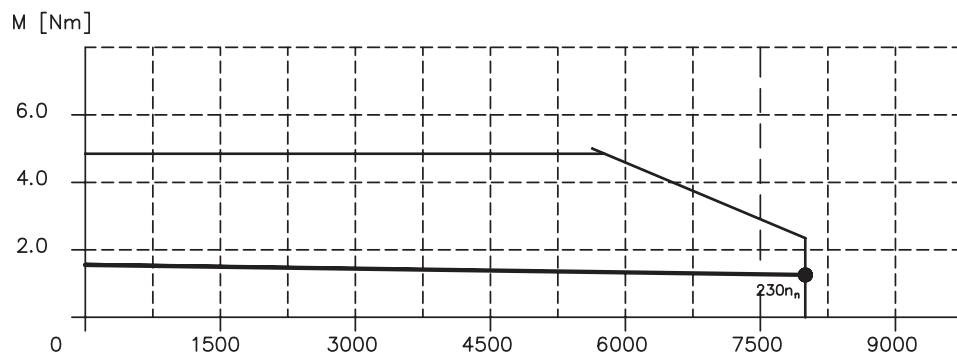

3.4

AKM3

Technical data

Data	Symbol [Unit]	AKM									
		31C	31E	31H	32C	32D	32H	33C	33E	33H	
Electrical data											
Standstill torque*	M_0 [Nm]	1,15	1,20	1,23	2,00	2,04	2,10	2,71	2,79	2,88	
Standstill current	I_{0rms} [A]	1,37	2,99	5,85	1,44	2,23	5,50	1,47	2,58	5,62	
max. Mains voltage	U_N [VAC]	480									
U = 75VDC	Rated speed	n_n [min ⁻¹]	—	750	2000	—	—	1200	—	—	800
	Rated torque*	M_n [Nm]	—	1,19	1,20	—	—	2,06	—	—	2,82
	Rated power	P_n [kW]	—	0,09	0,25	—	—	0,26	—	—	0,24
U _N = 115V	Rated speed	n_n [min ⁻¹]	—	2500	6000	—	1000	3000	—	—	2500
	Rated torque*	M_n [Nm]	—	1,17	0,97	—	2,00	1,96	—	—	2,66
	Rated power	P_n [kW]	—	0,31	0,61	—	0,21	0,62	—	—	0,70
U _N = 230V	Rated speed	n_n [min ⁻¹]	2500	6000	—	1500	2500	7000	1000	2000	5500
	Rated torque*	M_n [Nm]	1,12	0,95	—	1,95	1,93	1,45	2,64	2,62	2,27
	Rated power	P_n [kW]	0,29	0,60	—	0,31	0,51	1,06	0,28	0,55	1,31
U _N = 400V	Rated speed	n_n [min ⁻¹]	5000	—	—	3000	5500	—	2000	4500	—
	Rated torque*	M_n [Nm]	1,00	—	—	1,86	1,65	—	2,54	2,34	—
	Rated power	P_n [kW]	0,52	—	—	0,58	0,95	—	0,53	1,10	—
U _N = 480V	Rated speed	n_n [min ⁻¹]	6000	—	—	3500	6000	—	2500	5000	—
	Rated torque*	M_n [Nm]	0,91	—	—	1,83	1,58	—	2,50	2,27	—
	Rated power	P_n [kW]	0,57	—	—	0,67	0,99	—	0,65	1,19	—
Peak current	I_{0max} [A]	5,5	12,0	23,4	5,7	8,9	22,0	5,9	10,3	22,5	
Peak torque	M_{0max} [Nm]	3,88	4,00	4,06	6,92	7,05	7,26	9,76	9,96	10,2	
Torque constant	K_{Trms} [Nm/A]	0,85	0,41	0,21	1,40	0,92	0,39	1,86	1,10	0,52	
Voltage constant	K_{Erms} [mV/min]	54,5	26,1	13,7	89,8	59,0	24,8	120	70,6	33,4	
Winding resistance Ph-Ph	R_{25} [Ω]	21,4	4,58	1,25	23,0	9,57	1,64	25,4	8,36	1,82	
Winding inductance Ph-Ph	L [mH]	37,5	8,6	2,4	46,5	20,1	3,55	53,6	18,5	4,1	
Mechanical data											
Rotor moment of inertia	J [kgcm ²]	0,33		0,59		0,85					
Pole number		8		8		8					
Static friction torque	M_R [Nm]	0,014		0,02		0,026					
Thermal time constant	t_{TH} [min]	14		17		20					
Weight standard	G [kg]	1,55		2,23		2,9					
Radial load permitted at shaft end @ 3000 min ⁻¹	F_R [N]	195		195		195					
Axial load permitted at shaft end @ 3000 min ⁻¹	F_A [N]	65		65		65					

* reference flange Aluminium 254mm * 254mm * 6,35mm

Brake data

Data	Symbol [Unit]	Value
Holding torque @ 120°C	M_{BR} [Nm]	2,5
Operating voltage	U_{BR} [VDC]	24 ± 10 %
electrical power	P_{BR} [W]	10,1
Moment of inertia	J_{BR} [kgcm ²]	0,011
Release delay time	t_{BRH} [ms]	25
Application delay time	t_{BRL} [ms]	10
Weight of the brake	G_{BR} [kg]	0,35
Typical backlash	[°mech.]	0,46

Connections and cables

Data	AKM3
Power connection	4 + 4 poles, round, angular
Motorcable, shielded	4 x 1
Motor cable with control leads, shielded	4 x 1 + 2 x 0,75
Resolver connection	12 poles, round, angular
Resolver cable, shielded	4 x 2 x 0,25mm ²
Encoder connection (option)	17 poles, round, angular
Encoder cable, shielded	7 x 2 x 0,25mm ²

Dimensions (drawing in principle)

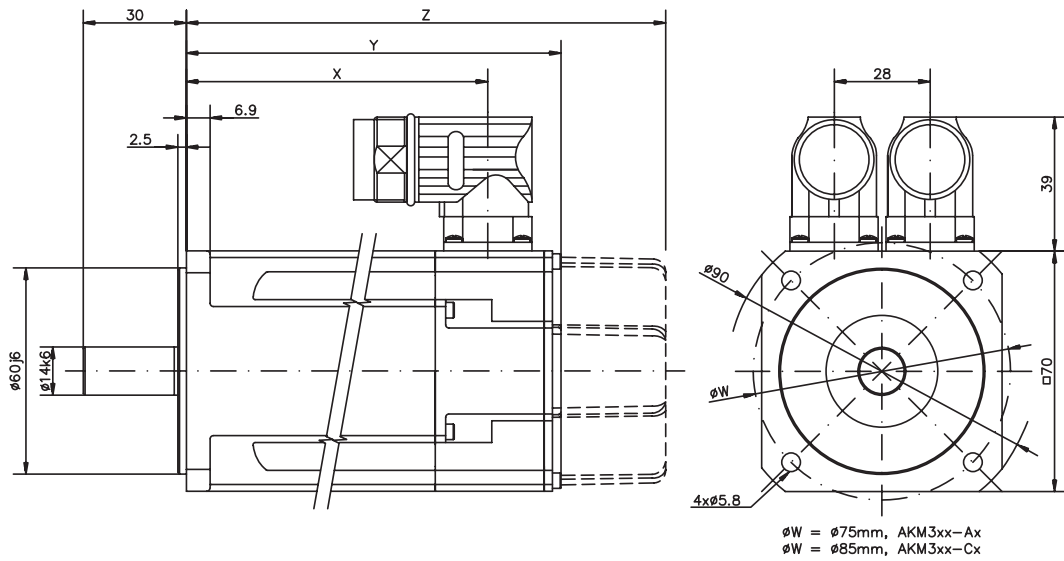

Model	X	Resolver/Encoder	
		Y	Z (brake)
AKM31	87.9	109.8	140.3
AKM32	118.9	140.8	171.3
AKM33	149.9	171.8	202.3

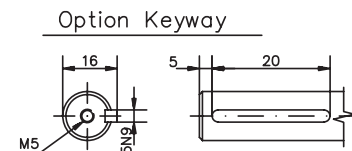

Radial-/axial forces at the shaft end

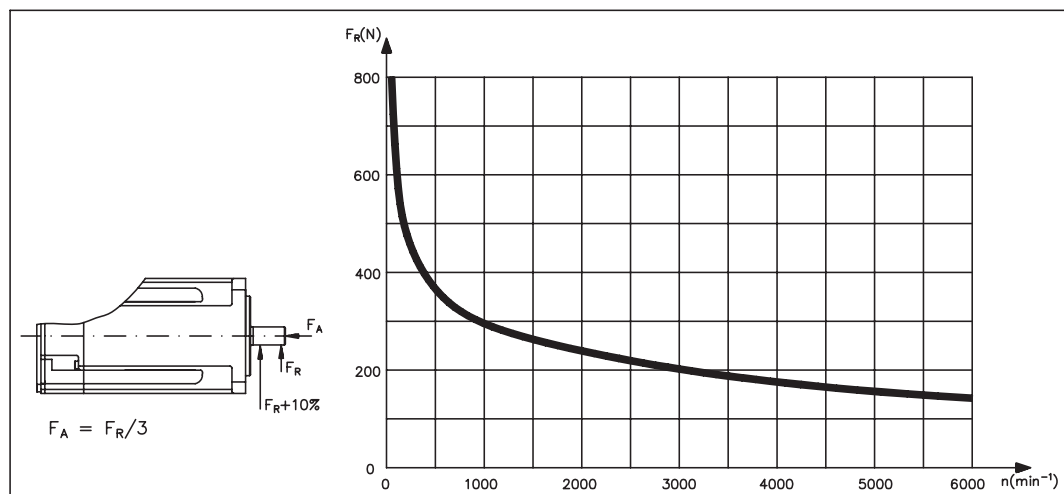

Performance curves

AKM31C

M [Nm]

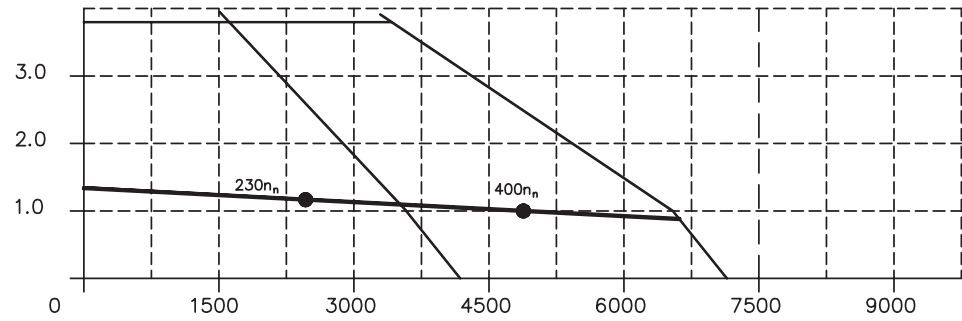

AKM31E

M [Nm]

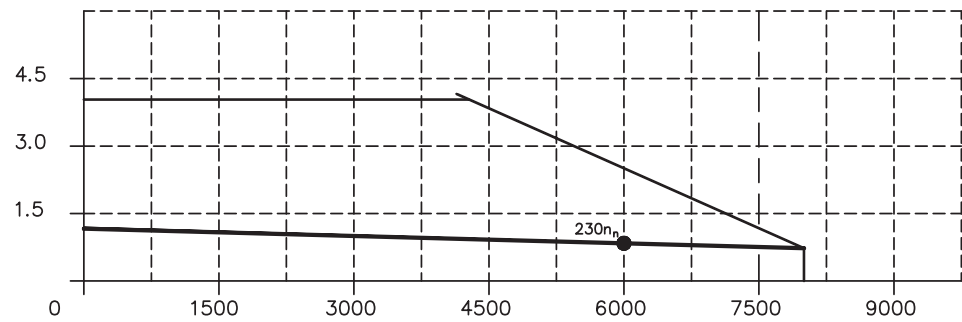

AKM31H

M [Nm]

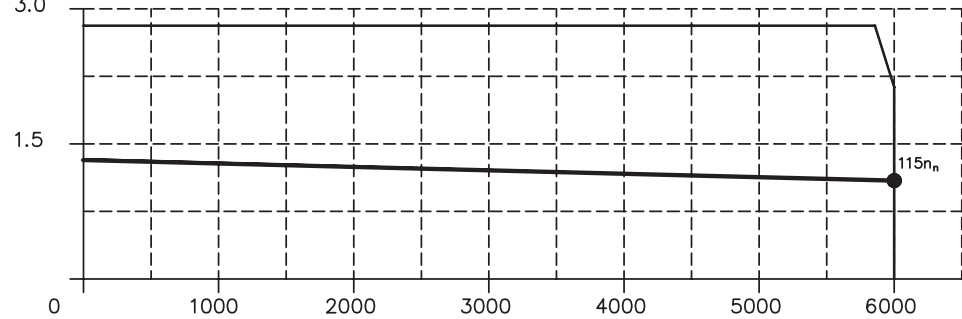

AKM32C

M [Nm]

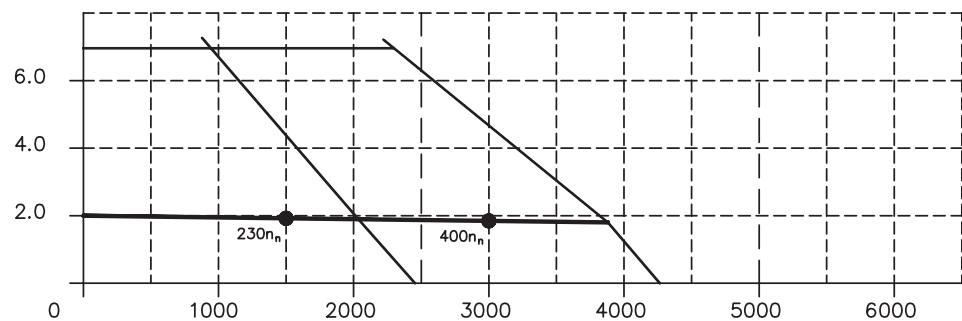

AKM32D

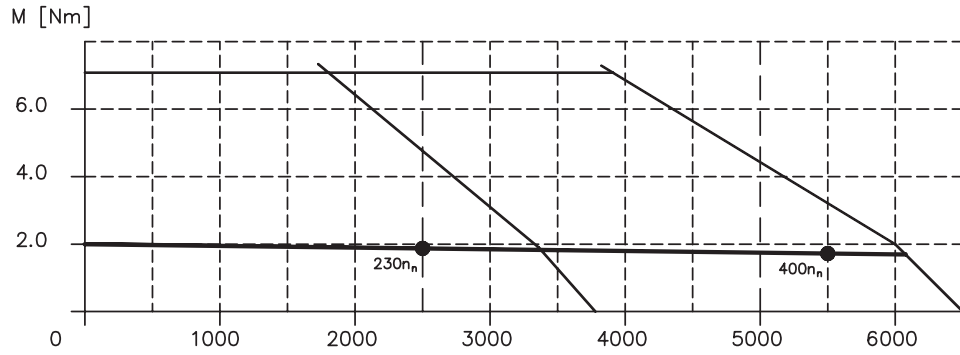

AKM32H

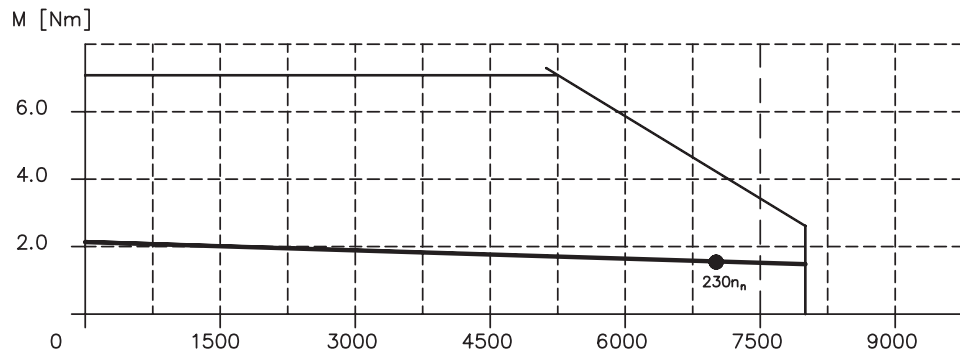

AKM33C

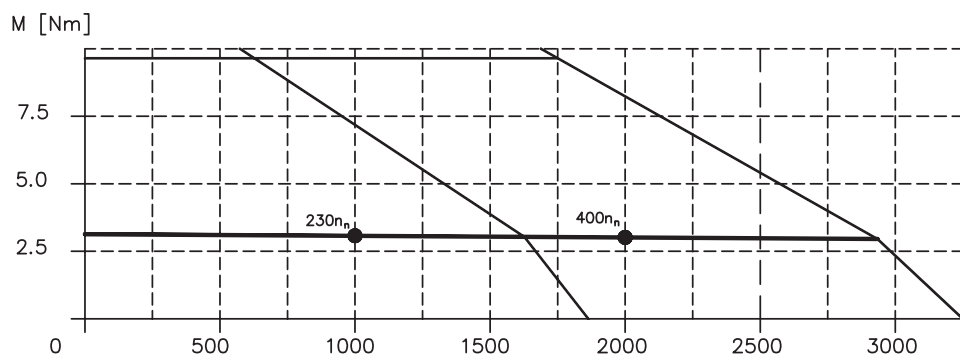

AKM33E

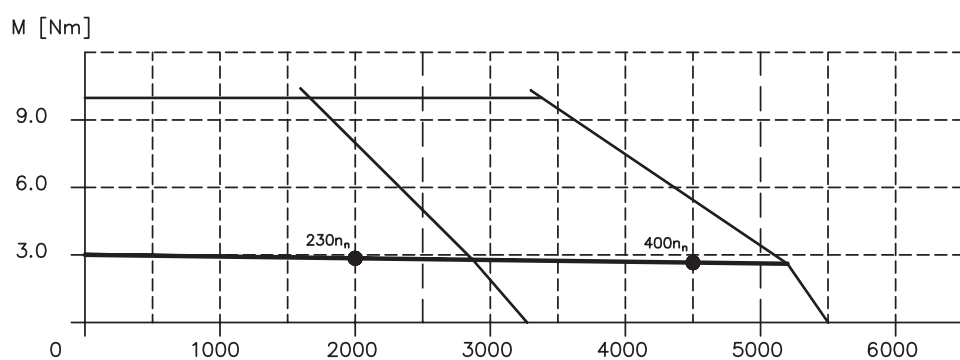

AKM33H

M [Nm]

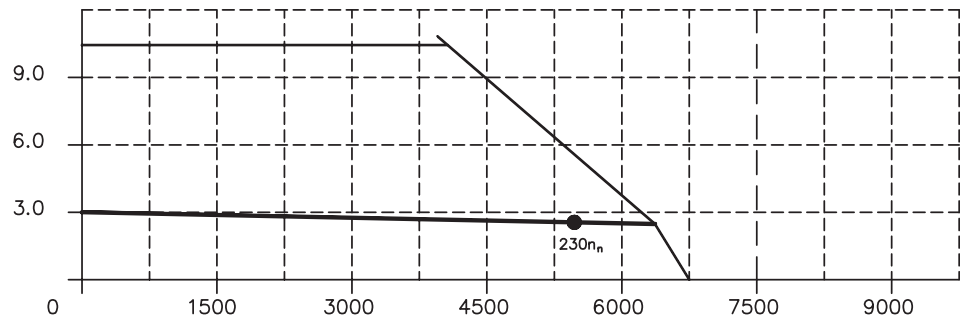

3.5 AKM4

Technical data

Data	Symbol [Unit]	AKM													
		41C	41E	41H	42C	42E	42G	42J	43E	43G	43K	44E	44G	44J	
Electrical data															
Standstill torque*	M ₀ [Nm]	1,95	2,02	2,06	3,35	3,42	3,53	3,56	4,70	4,80	4,90	5,76	5,88	6,00	
Standstill current	I _{0rms} [A]	1,46	2,85	5,60	1,40	2,74	4,80	8,40	2,76	4,87	9,60	2,90	5,00	8,80	
max. Mains voltage	U _N [VAC]	480													
U = 75VDC	Rated speed	n _n [min ⁻¹]	—	—	1000	—	—	—	—	—	—	—	—	—	
	Rated torque*	M _n [Nm]	—	—	1,99	—	—	—	—	—	—	—	—		
	Rated power	P _n [kW]	—	—	0,21	—	—	—	—	—	—	—	—		
U _N = 115V	Rated speed	n _n [min ⁻¹]	—	1200	3000	—	—	—	3000	—	—	2500	—	—	
	Rated torque*	M _n [Nm]	—	1,94	1,86	—	—	—	3,03	—	—	4,08	—	—	
	Rated power	P _n [kW]	—	0,24	0,58	—	—	—	0,95	—	—	1,07	—	—	
U _N = 230V	Rated speed	n _n [min ⁻¹]	1200	3000	6000	—	1800	3500	6000	1500	2500	6000	1200	2000	4000
	Rated torque*	M _n [Nm]	1,88	1,82	1,62	—	3,12	2,90	2,38	4,24	4,00	2,62	5,22	4,90	3,84
	Rated power	P _n [kW]	0,24	0,57	1,02	—	0,59	1,06	1,50	0,67	1,05	1,65	0,66	1,03	1,61
U _N = 400V	Rated speed	n _n [min ⁻¹]	3000	6000	—	1500	3500	6000	—	2500	5000	—	2000	4000	6000
	Rated torque*	M _n [Nm]	1,77	1,58	—	3,10	2,81	2,35	—	3,92	3,01	—	4,80	3,76	2,75
	Rated power	P _n [kW]	0,56	0,99	—	0,49	1,03	1,48	—	1,03	1,58	—	1,01	1,57	1,73
U _N = 480V	Rated speed	n _n [min ⁻¹]	3500	6000	—	2000	4000	6000	—	3000	6000	—	2500	5000	6000
	Rated torque*	M _n [Nm]	1,74	1,58	—	3,02	2,72	2,35	—	3,76	2,57	—	4,56	3,19	2,75
	Rated power	P _n [kW]	0,64	0,99	—	0,63	1,14	1,48	—	1,18	1,61	—	1,19	1,67	1,73
Peak current	I _{0max} [A]	5,8	11,4	22,4	5,61	11,0	19,2	33,7	11,0	19,5	38,3	11,4	20,0	35,2	
Peak torque	M _{0max} [Nm]	6,12	6,28	6,36	11,1	11,3	11,5	11,6	15,9	16,1	16,3	19,9	20,2	20,4	
Torque constant	K _{Trms} [Nm/A]	1,34	0,71	0,37	2,40	1,26	0,74	0,43	1,72	0,99	0,52	2,04	1,19	0,69	
Voltage constant	K _{E rms} [mVmin]	86,3	45,6	23,7	154	80,9	47,5	27,5	111	63,9	33,2	132	76,6	44,2	
Winding resistance Ph-Ph	R ₂₅ [Ω]	21,7	5,7	1,51	27,5	7,22	2,38	0,80	8,04	2,61	0,70	8,08	2,65	0,88	
Winding inductance Ph-Ph	L [mH]	66,1	18,4	5,0	97,4	26,8	9,2	3,1	32,6	10,8	2,9	33,9	11,5	3,8	
Mechanical data															
Rotor moment of inertia	J [kgcm ²]	0,81			1,5				2,1			2,7			
Pole number		10			10				10			10			
Static friction torque	M _R [Nm]	0,014			0,026				0,038			0,05			
Thermal time constant	t _{TH} [min]	13			17				20			24			
Weight standard	G [kg]	2,44			3,39				4,35			5,3			
Radial load permitted at shaft end @ 3000 min ⁻¹	F _R [N]	450													
Axial load permitted at shaft end @ 3000 min ⁻¹	F _A [N]	180													

* reference flange Aluminium 254mm * 254mm * 6,35mm

Brake data

Data	Symbol [Unit]	Value
Holding torque @ 120°C	M _{BR} [Nm]	6
Operating voltage	U _{BR} [VDC]	24 ± 10 %
electrical power	P _{BR} [W]	12,8
Moment of inertia	J _{BR} [kgcm ²]	0,068
Release delay time	t _{BRH} [ms]	35
Application delay time	t _{BRL} [ms]	15
Weight of the brake	G _{BR} [kg]	0,63
Typical backlash	[°mech.]	0,37

Connections and cables

Data	AKM4
Power connection	4 + 4 poles, round, angular
Motorcable, shielded	4 x 1,5
Motor cable with control leads, shielded	4 x 1 + 2 x 0,75
Resolver connection	12 poles, round, angular
Resolver cable, shielded	4 x 2 x 0,25mm ²
Encoder connection (option)	17 poles, round, angular
Encoder cable, shielded	7 x 2 x 0,25mm ²

Dimensions (drawing in principle)

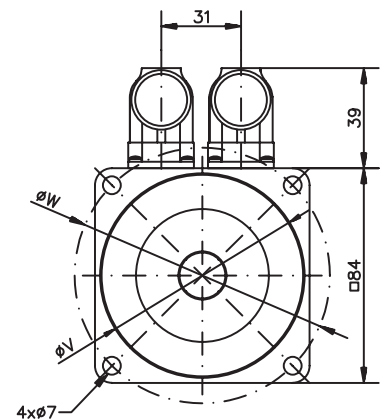
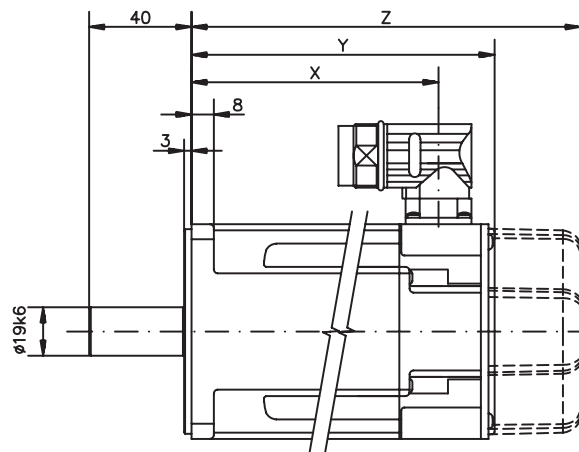

øW=ø100, øV=ø80j6, AKM4xx-Ax
øW=ø90, øV=ø60j6, AKM4xx-Cx

Model	X	Resolver/Encoder	
		Y	Z (brake)
AKM41	96.4	118.8	152.3
AKM42	125.5	147.8	181.3
AKM43	154.4	176.8	210.3
AKM44	183.4	205.8	239.3

Option Keyway

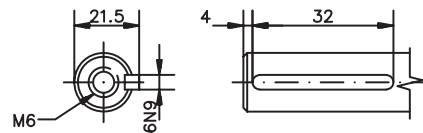

Radial-/axial forces at the shaft end

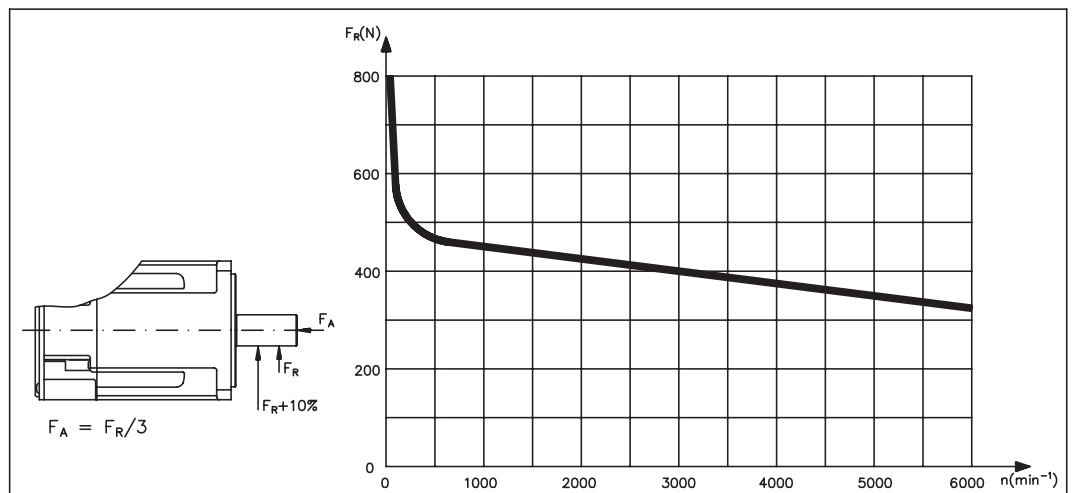

Performance curves

AKM41C

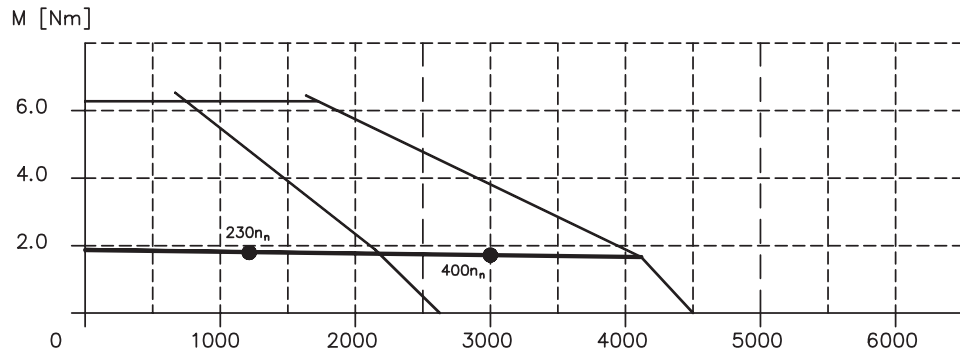

AKM41E

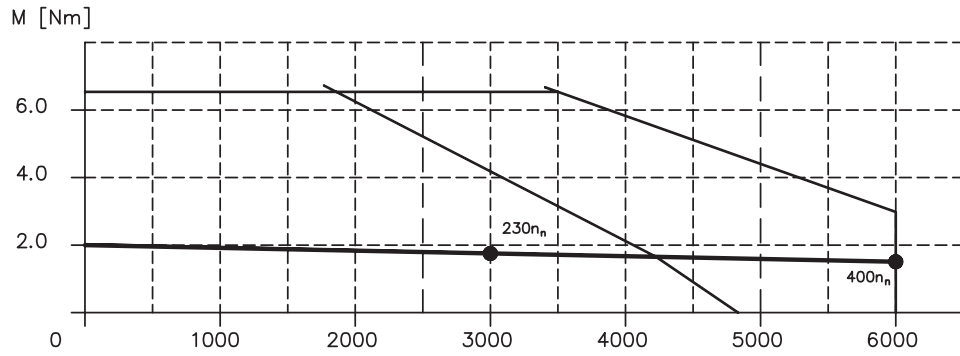

AKM41H

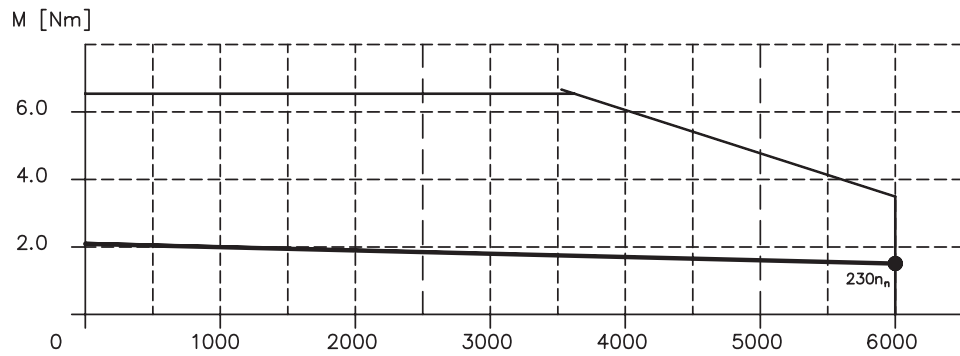

AKM42C

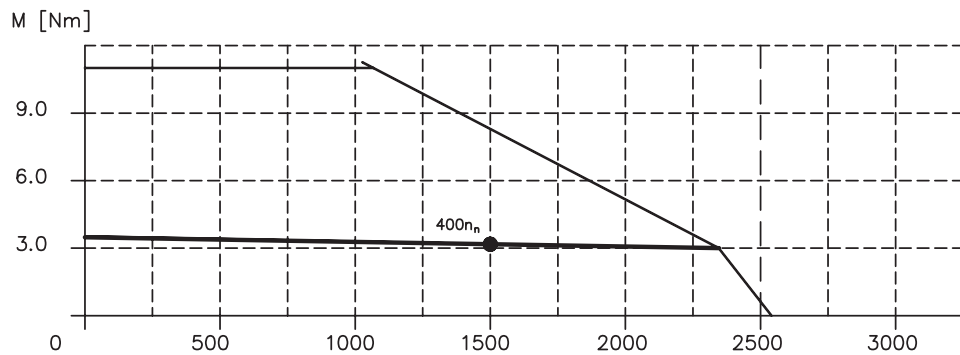

AKM42E

M [Nm]

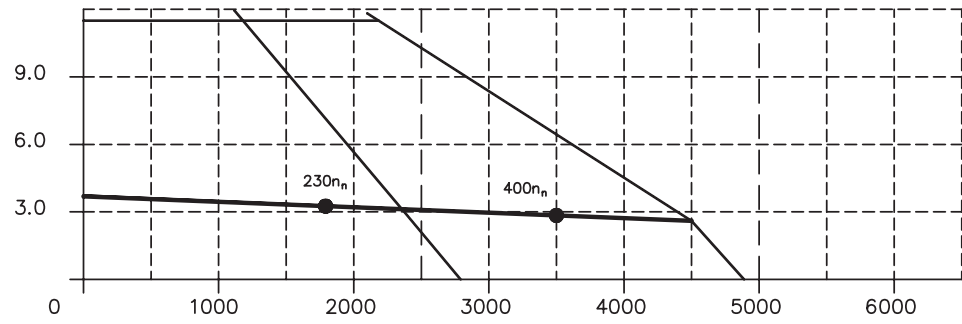

AKM42G

M [Nm]

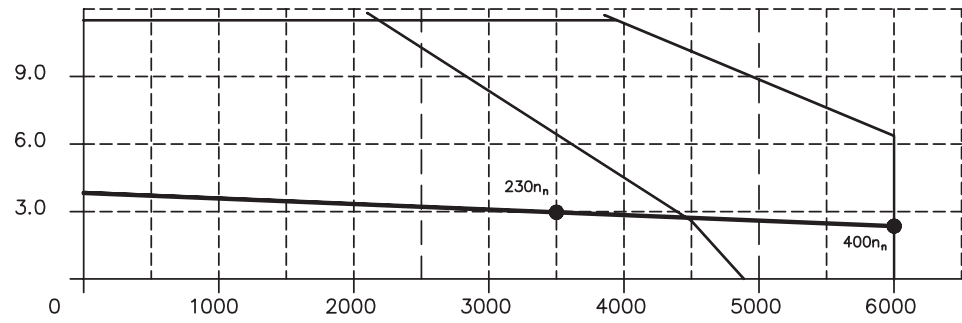

AKM42J

M [Nm]

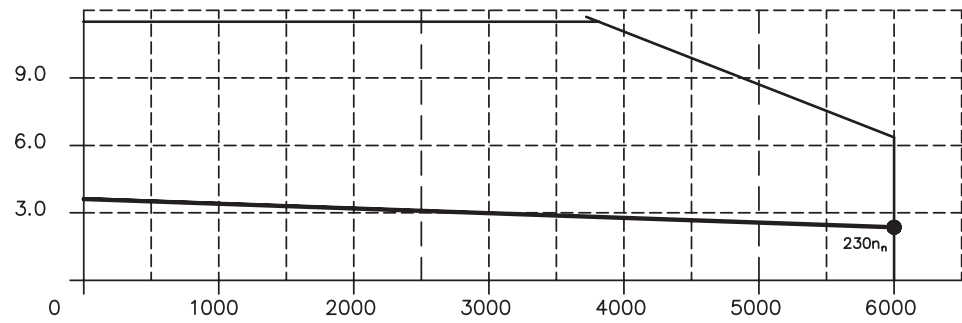

AKM43E

M [Nm]

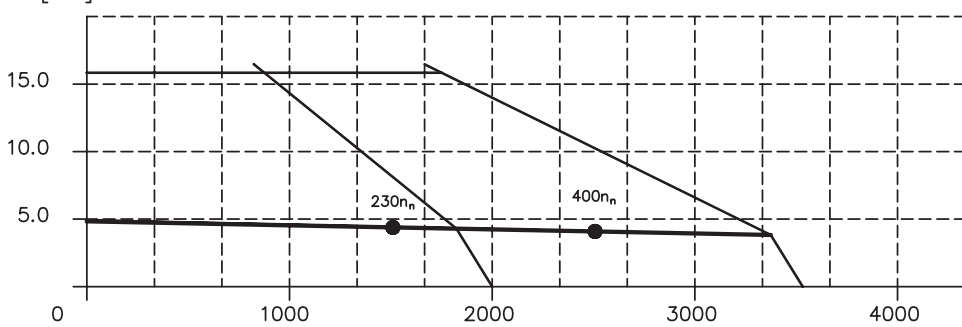

AKM43G

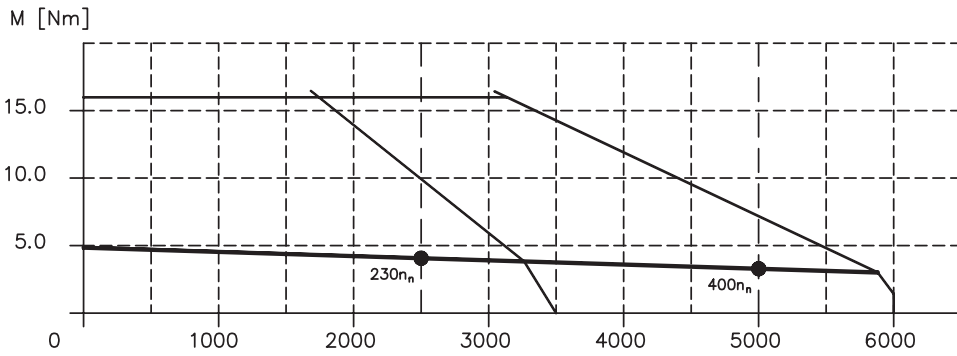

AKM43K

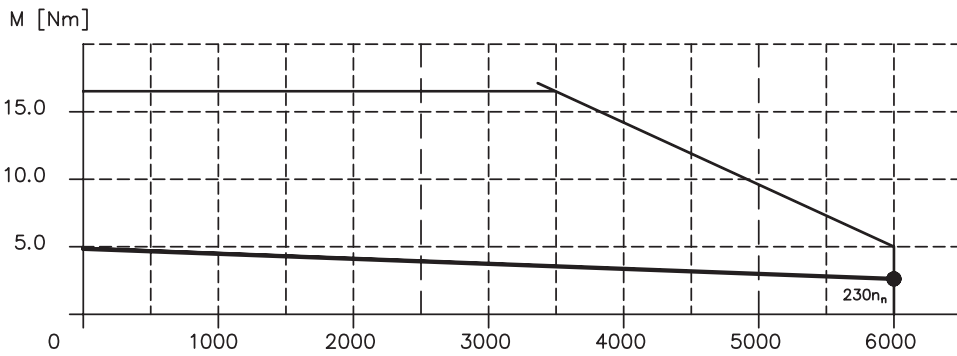

AKM44E

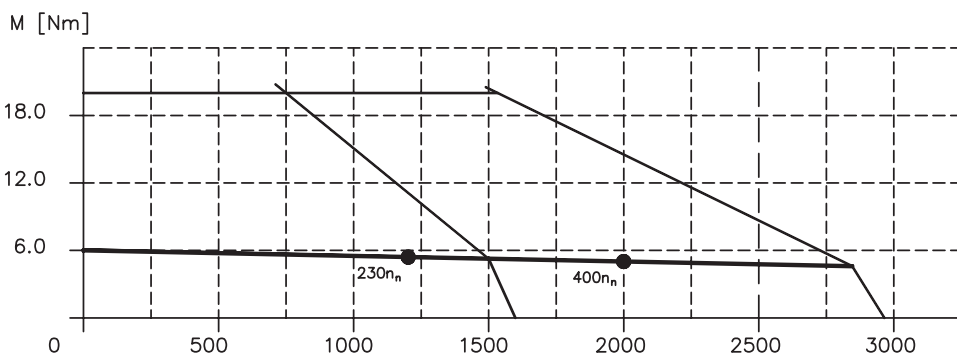

AKM44G

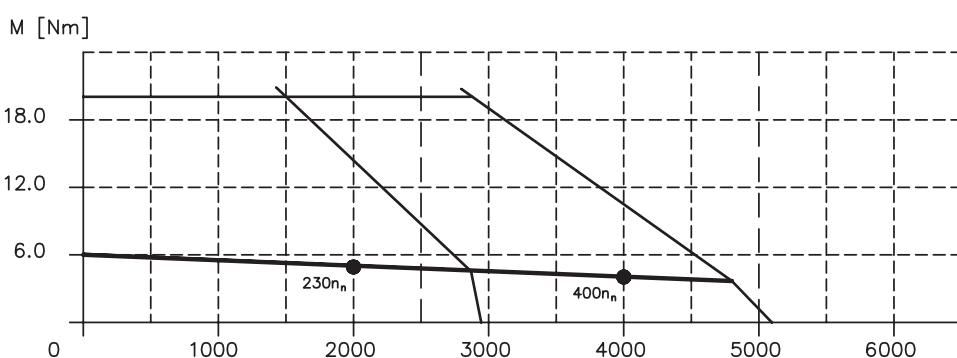

AKM44J

M [Nm]

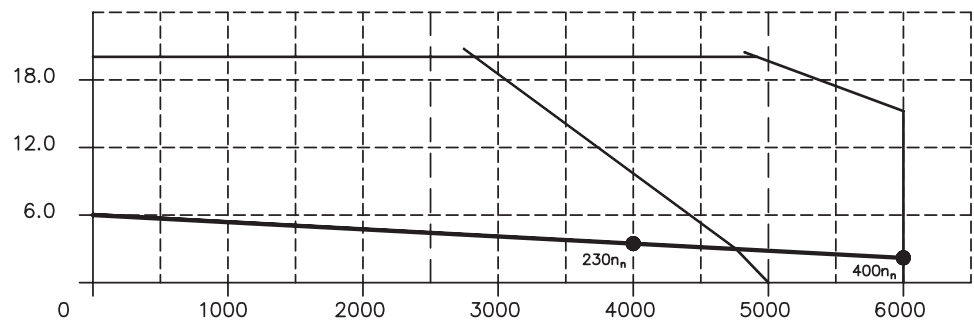

3.6 AKM5

Technical data

Data	Symbol [Unit]	AKM															
		51E	51G	51K	52E	52G	52K	52M	53G	53K	53M	53P	54G	54K	54L	54N	
Electrical data																	
Standstill torque*	M ₀ [Nm]	4,70	4,75	4,90	8,34	8,43	8,60	8,60	11,4	11,6	11,4	11,4	14,3	14,4	14,1	14,1	
Standstill current	I _{0rms} [A]	2,75	4,84	9,4	2,99	4,72	9,3	13,1	4,77	9,4	13,4	19,1	5,0	9,7	12,5	17,8	
max. Mains voltage	U _N [VAC]	480															
U = 75VDC	Rated speed	n _n [min ⁻¹]	—	—	—	—	—	—	—	—	—	—	—	—	—	—	
	Rated torque*	M _n [Nm]	—	—	—	—	—	—	—	—	—	—	—	—	—	—	
	Rated power	P _n [kW]	—	—	—	—	—	—	—	—	—	—	—	—	—	—	
U _N = 115V	Rated speed	n _n [min ⁻¹]	—	—	2500	—	—	—	—	—	—	—	—	—	—	—	
	Rated torque*	M _n [Nm]	—	—	4,15	—	—	—	—	—	—	—	—	—	—		
	Rated power	P _n [kW]	—	—	1,09	—	—	—	—	—	—	—	—	—	—		
U _N = 230V	Rated speed	n _n [min ⁻¹]	1200	2500	5500	—	1500	3000	4500	1000	2000	3000	5000	—	1800	2500	3500
	Rated torque*	M _n [Nm]	4,41	4,02	2,35	—	7,69	6,80	5,20	10,7	10,1	8,72	5,88	—	12,7	11,5	9,85
	Rated power	P _n [kW]	0,55	1,05	1,35	—	1,21	2,14	2,45	1,12	2,12	2,74	3,08	—	2,39	3,00	3,61
U _N = 400V	Rated speed	n _n [min ⁻¹]	2500	5000	—	1500	2500	5500	—	2000	4000	—	—	1500	3500	4500	—
	Rated torque*	M _n [Nm]	3,98	2,62	—	7,61	7,06	3,90	—	9,85	7,65	—	—	12,9	10,0	8,13	—
	Rated power	P _n [kW]	1,04	1,37	—	1,20	1,85	2,25	—	2,06	3,20	—	—	2,03	3,68	3,83	—
U _N = 480V	Rated speed	n _n [min ⁻¹]	3000	6000	—	2000	3000	6000	—	2400	4500	—	—	2000	4000	—	—
	Rated torque*	M _n [Nm]	3,80	1,94	—	7,28	6,66	3,25	—	9,50	6,85	—	—	12,3	9,25	—	—
	Rated power	P _n [kW]	1,19	1,22	—	1,52	2,09	2,04	—	2,39	3,23	—	—	2,57	3,87	—	—
Peak current	I _{0max} [A]	8,24	14,5	28,3	9,00	14,2	27,8	39,4	14,3	28,1	40,3	57,4	14,9	29,2	37,5	53,4	
Peak torque	M _{0max} [Nm]	11,6	11,7	12,0	21,3	21,5	21,9	21,9	29,7	30,1	29,8	29,8	37,8	38,4	37,5	37,6	
Torque constant	K _{Trms} [Nm/A]	1,72	0,99	0,52	2,79	1,79	0,93	0,66	2,39	1,24	0,85	0,60	2,88	1,50	1,13	0,80	
Voltage constant	K _{Erms} [mVmin]	110	63,6	33,5	179	115	60,1	42,4	154	79,8	54,7	38,4	185	96,6	72,9	51,3	
Winding resistance Ph-Ph	R ₂₅ [Ω]	8,47	2,75	0,75	8,59	3,47	0,93	0,48	3,75	1,00	0,51	0,27	3,80	1,02	0,63	0,33	
Winding inductance Ph-Ph	L [mH]	36,6	12,1	3,40	44,7	18,5	5,00	2,50	21,3	5,70	2,70	1,30	22,9	6,20	3,50	1,80	
Mechanical data																	
Rotor moment of inertia	J [kgcm ²]	3,4			6,2			9,1			12						
Pole number		10			10			10			10						
Static friction torque	M _R [Nm]	0,022			0,04			0,058			0,077						
Thermal time constant	t _{TH} [min]	20			24			28			31						
Weight standard	G [kg]	4,2			5,8			7,4			9						
Radial load permitted at shaft end @ 3000 min ⁻¹	F _R [N]	450															
Axial load permitted at shaft end @ 3000 min ⁻¹	F _A [N]	180															

* reference flange Aluminium 305mm * 305mm * 12,7mm

Brake data

Data	Symbol [Unit]	Value
Holding torque @ 120°C	M _{BR} [Nm]	14,5
Operating voltage	U _{BR} [VDC]	24 ± 10 %
electrical power	P _{BR} [W]	19,5
Moment of inertia	J _{BR} [kgcm ²]	0,173
Release delay time	t _{BRH} [ms]	80
Application delay time	t _{BRL} [ms]	15
Weight of the brake	G _{BR} [kg]	1,1
Typical backlash	[°mech.]	0,31

Connections and cables

Data	AKM5	
Power connection	4 + 4 poles, round, angular	
Motorcable, shielded	4 x 1,5	4 x 2,5
Motor cable with control leads, shielded	4 x 1,5 + 2 x 0,75	4 x 2,5 + 2 x 1
Resolver connection	12 poles, round, angular	
Resolver cable, shielded	4 x 2 x 0,25mm ²	
Encoder connection (option)	17 poles, round, angular	
Encoder cable, shielded	7 x 2 x 0,25mm ²	

Dimensions (drawing in principle)

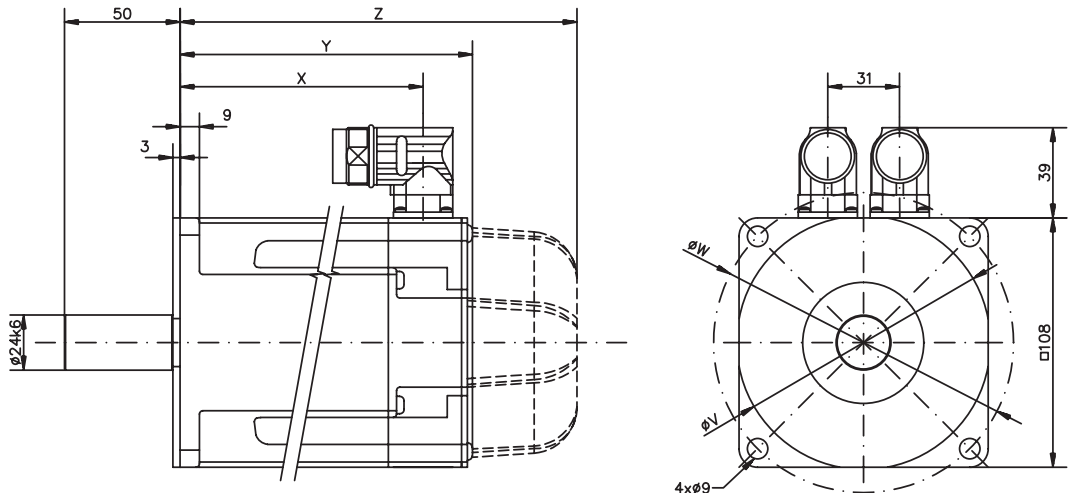

øW=ø130, øV=ø110j6, AKM5xx-Ax
øW=ø115, øV=ø95j6, AKM5xx-Cx

Model	X	Resolver/Comcoder		Encoder	
		Y	Z (brake)	Y	Z (brake)
AKM51	105.3	127.5	172.5	146.0	189.0
AKM52	136.3	158.5	203.5	177.0	220.0
AKM53	167.3	189.5	234.5	208.0	251.0
AKM54	198.3	220.5	265.5	239.0	282.0

Option Keyway

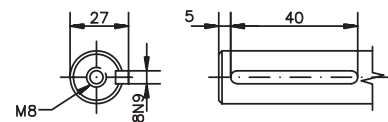

Radial-/axial forces at the shaft end

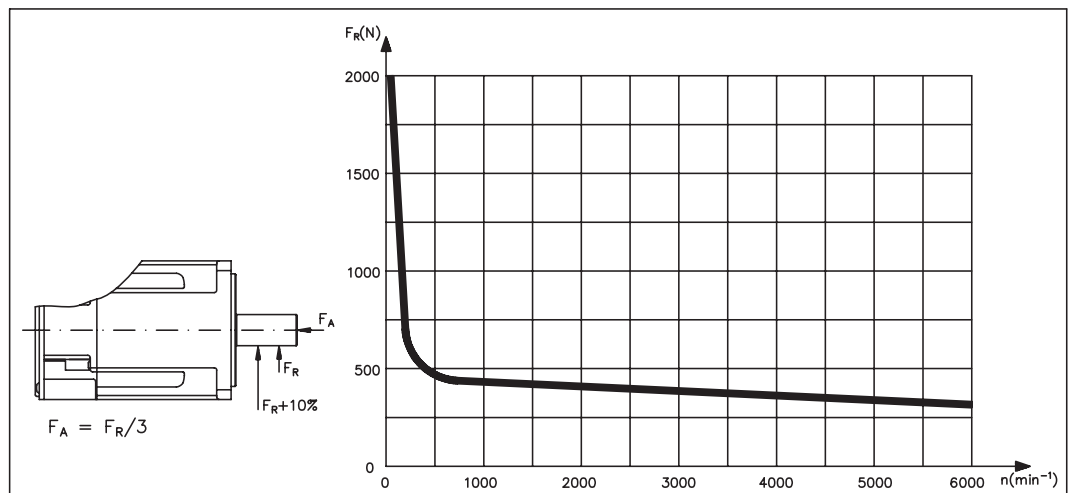

Performance curves

AKM51E

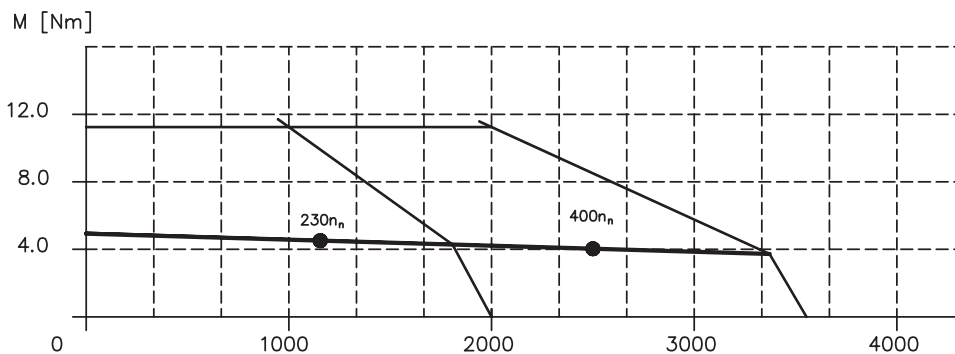

AKM51G

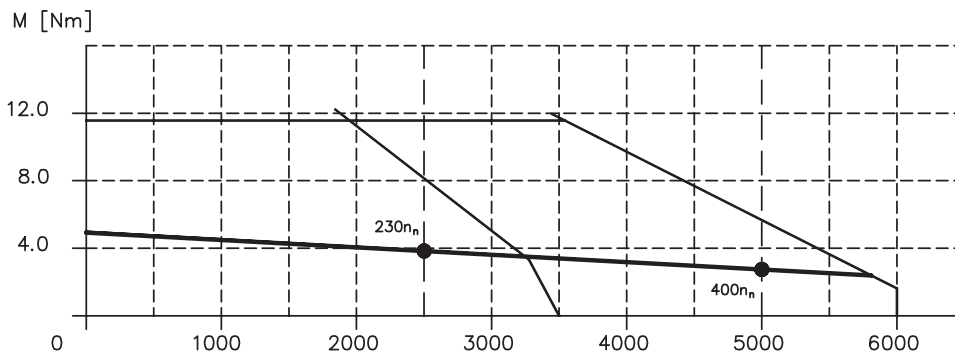

AKM51K

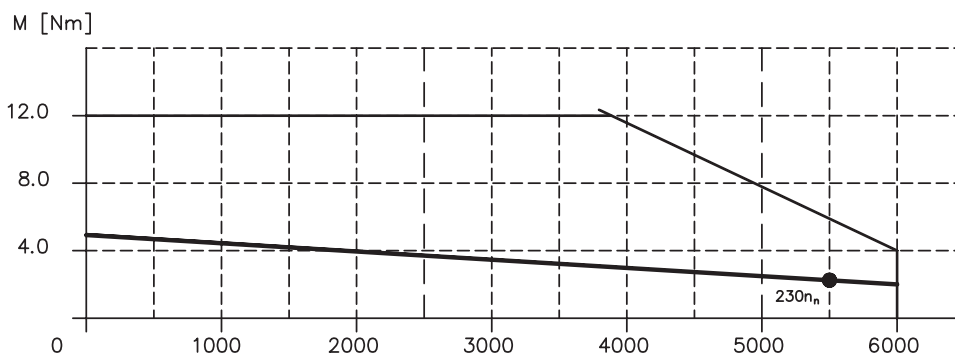

AKM52E

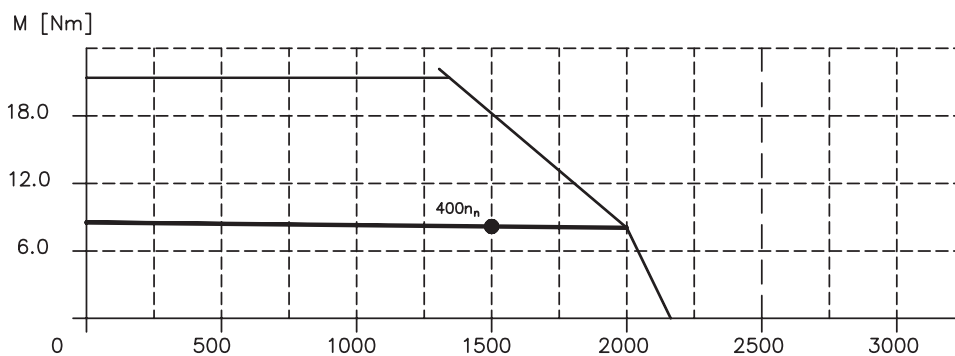

AKM52G

M [Nm]

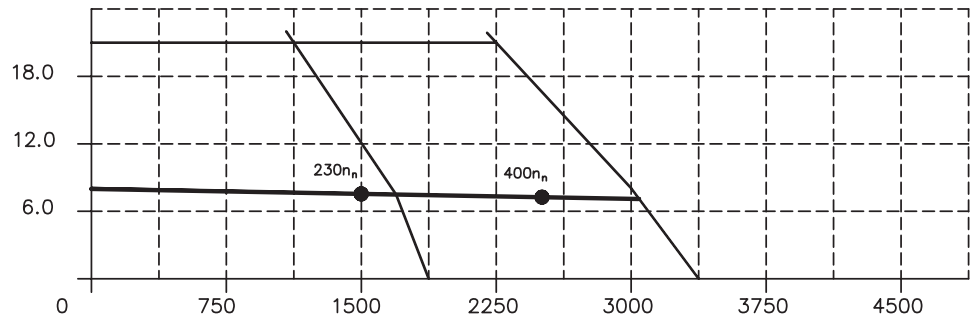

AKM52K

M [Nm]

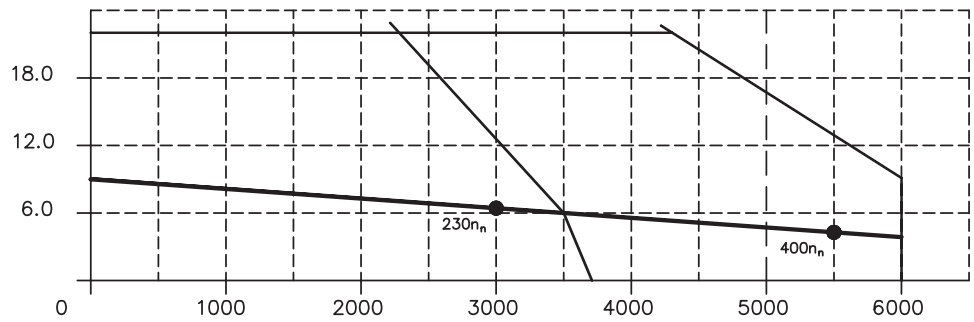

AKM52M

M [Nm]

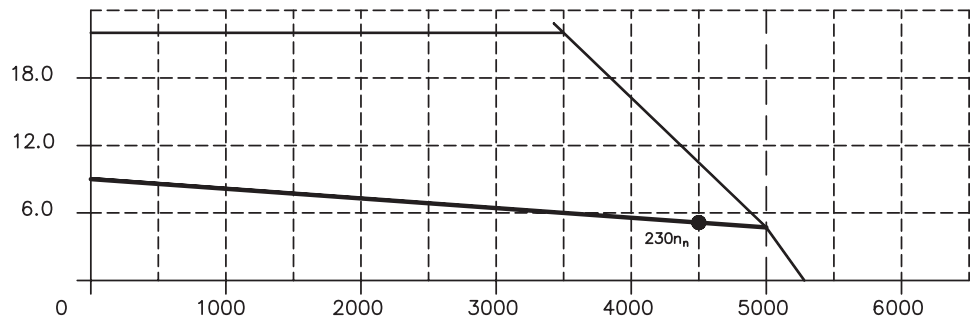

AKM53G

M [Nm]

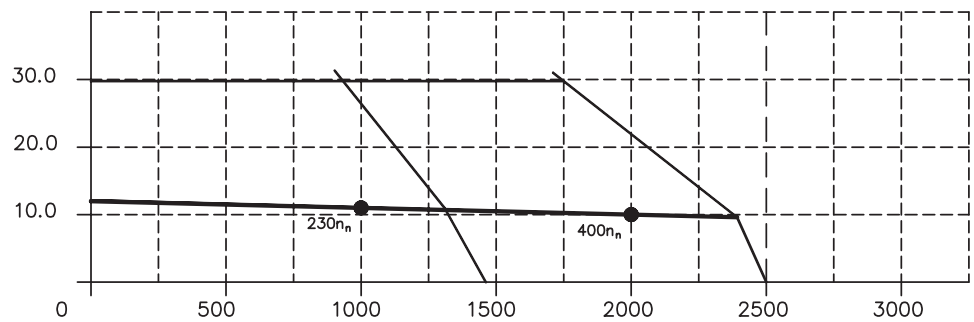

AKM53K

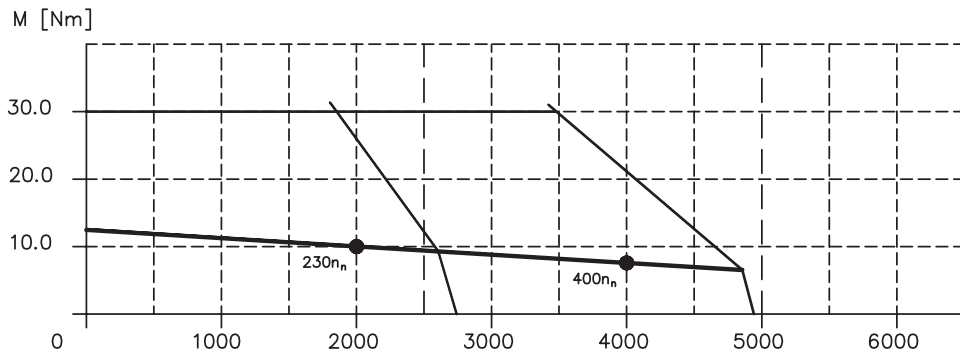

AKM53M

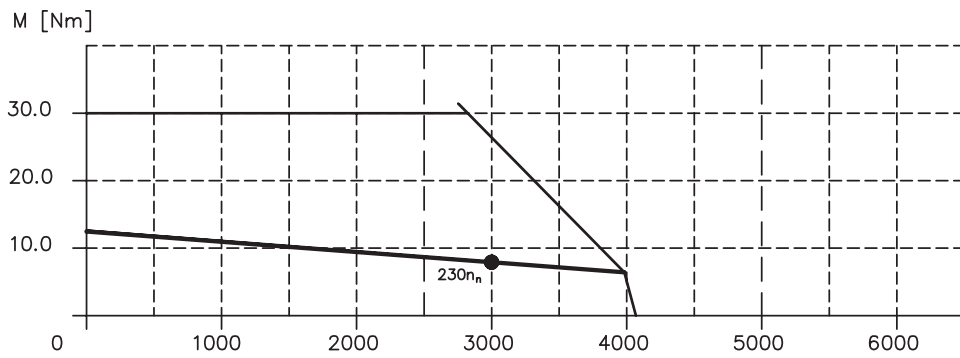

AKM53P

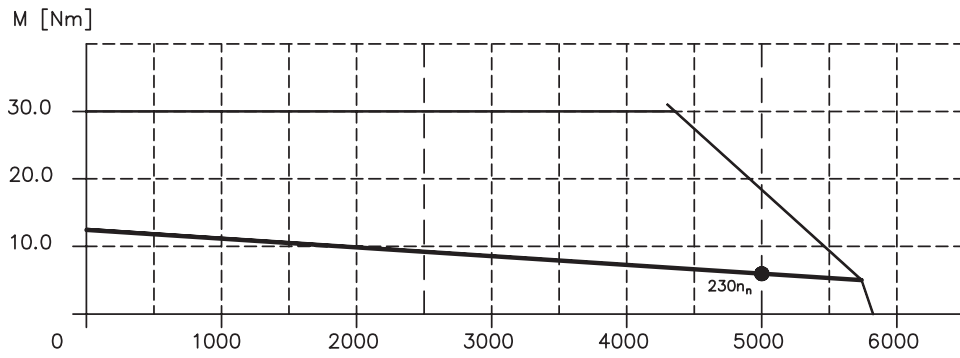

AKM54G

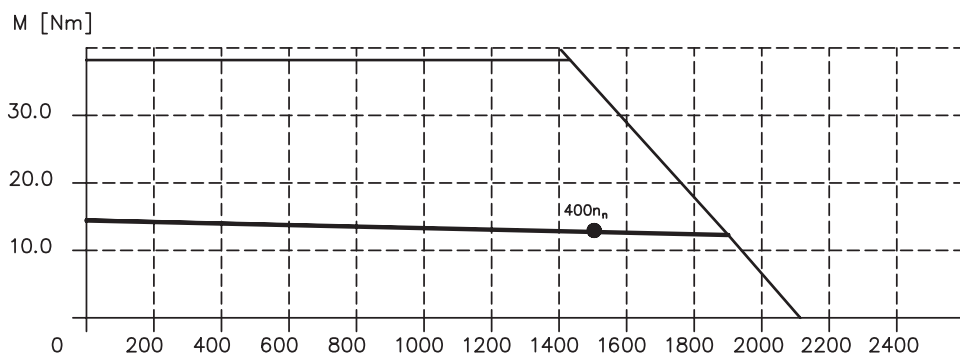

AKM54K

M [Nm]

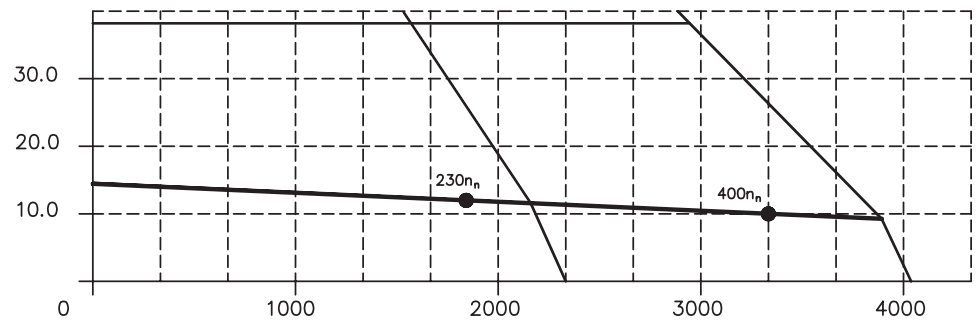

AKM54L

M [Nm]

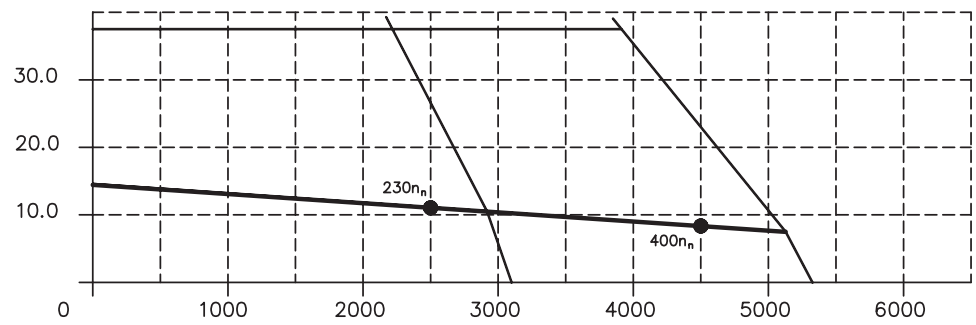

AKM54N

M [Nm]

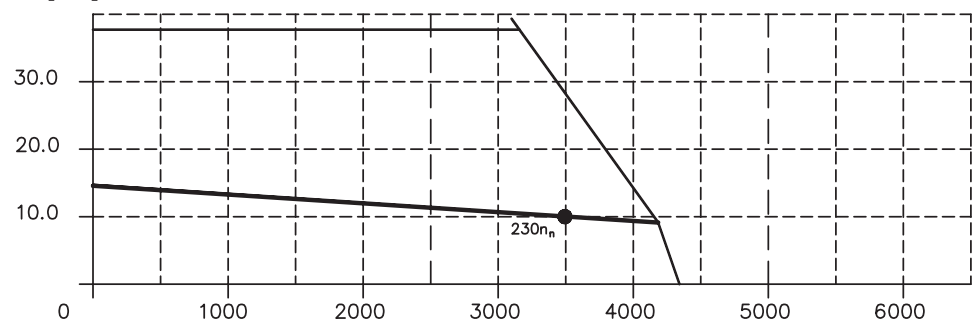

3.7 AKM6

Technical data

Data	Symbol [Unit]	AKM														
		62G	62K	62M	62P	63G	63K	63M	63N	64K	64L	64P	65K	65M	65N	
Electrical data																
Standstill torque*	M ₀ [Nm]	11,9	12,2	12,2	12,3	16,5	16,8	17,0	17,0	20,8	21,0	20,4	24,8	25,0	24,3	
	Standstill current	I _{0rms} [A]	4,9	9,6	13,4	18,8	4,5	9,9	13,8	17,4	9,2	12,8	18,6	9,8	13,6	17,8
Mains voltage	U _N [VAC]	230-480														
U = 75VDC	Rated speed	n _n [min ⁻¹]	—	—	—	—	—	—	—	—	—	—	—	—	—	
	Rated torque*	M _n [Nm]	—	—	—	—	—	—	—	—	—	—	—	—	—	
	Rated power	P _n [kW]	—	—	—	—	—	—	—	—	—	—	—	—	—	
U _N = 115V	Rated speed	n _n [min ⁻¹]	—	—	—	—	—	—	—	—	—	—	—	—	—	
	Rated torque*	M _n [Nm]	—	—	—	—	—	—	—	—	—	—	—	—	—	
	Rated power	P _n [kW]	—	—	—	—	—	—	—	—	—	—	—	—	—	
U _N = 230V	Rated speed	n _n [min ⁻¹]	—	2000	3000	4500	—	1500	2000	3000	1200	1500	2500	1000	1500	2000
	Rated torque*	M _n [Nm]	—	10,4	9,50	8,10	—	14,9	14,3	13,0	18,8	18,4	16,0	22,8	21,9	19,8
	Rated power	P _n [kW]	—	2,18	2,98	3,82	—	2,34	2,99	4,08	2,36	2,89	4,19	2,39	3,44	4,15
U _N = 400V	Rated speed	n _n [min ⁻¹]	1800	3500	6000	—	1200	3000	4000	5000	2000	3000	4500	2000	2500	3500
	Rated torque*	M _n [Nm]	10,4	9,00	5,70	—	14,9	12,9	11,3	9,60	17,2	15,6	11,9	20,2	19,2	16,0
	Rated power	P _n [kW]	1,96	3,30	3,58	—	1,87	4,05	4,73	5,03	3,60	4,90	5,61	4,23	5,03	5,86
U _N = 480V	Rated speed	n _n [min ⁻¹]	2000	4500	6000	—	1500	3500	4500	6000	2500	3500	5500	2200	3000	4000
	Rated torque*	M _n [Nm]	10,2	8,00	5,70	—	14,6	12,0	10,5	7,00	16,3	14,4	9,00	19,7	18,1	14,7
	Rated power	P _n [kW]	2,14	3,77	3,58	—	2,29	4,40	4,95	4,40	4,27	5,28	5,18	4,54	5,69	6,16
Peak current	I _{0max} [A]	14,6	28,7	40,3	56,5	13,4	29,7	41,4	52,2	27,5	38,4	55,9	29,4	40,9	53,3	
Peak torque	M _{0max} [Nm]	29,8	30,1	30,2	30,4	41,8	42,6	43,0	43,0	53,5	54,1	52,9	64,5	65,2	63,7	
Torque constant	K _{Trms} [Nm/A]	2,47	1,28	0,91	0,66	3,70	1,71	1,24	0,98	2,28	1,66	1,10	2,54	1,85	1,38	
Voltage constant	K _{Erms} [mV/min]	159	82,1	58,8	42,2	238	110	79,9	63,3	147	107	71,0	164	119	88,8	
Winding resistance Ph-Ph	R ₂₅ [Ω]	3,94	1,05	0,55	0,30	5,16	1,09	0,58	0,38	1,34	0,71	0,36	1,27	0,68	0,42	
Winding inductance Ph-Ph	L [mH]	31,7	8,5	4,4	2,2	43,5	9,3	4,9	3,1	11,8	6,2	2,8	11,4	6,1	3,4	
Mechanical data																
Rotor moment of inertia	J [kgcm ²]	17			24			32			40					
Pole number		10			10			10			10					
Static friction torque	M _R [Nm]	0,05			0,1			0,15			0,2					
Thermal time constant	t _{TH} [min]	20			25			30			35					
Weight standard	G [kg]	8,9			11,1			13,3			15,4					
Radial load permitted at shaft end @ 3000 min ⁻¹	F _R [N]	770														
Axial load permitted at shaft end @ 3000 min ⁻¹	F _A [N]	280														

* reference flange Aluminium 457mm * 457mm * 12,7mm

Brake data

Data	Symbol [Unit]	Value
Holding torque @ 120°C	M _{BR} [Nm]	25
Operating voltage	U _{BR} [VDC]	24 ± 10 %
electrical power	P _{BR} [W]	25,7
Moment of inertia	J _{BR} [kgcm ²]	0,61
Release delay time	t _{BRH} [ms]	105
Application delay time	t _{BRL} [ms]	20
Weight of the brake	G _{BR} [kg]	2
Typical backlash	[°mech.]	0,24

Connections and cables

Data	AKM6
Power connection	4 + 4 poles, round, angular
Motor cable, shielded	4 x 2,5
Motor cable with control leads, shielded	4 x 2,5 + 2 x 1
Resolver connection	12 poles, round, angular
Resolver cable, shielded	4 x 2 x 0,25mm ²
Encoder connection (option)	17 poles, round, angular
Encoder cable, shielded	7 x 2 x 0,25mm ²

Dimensions (drawing in principle)

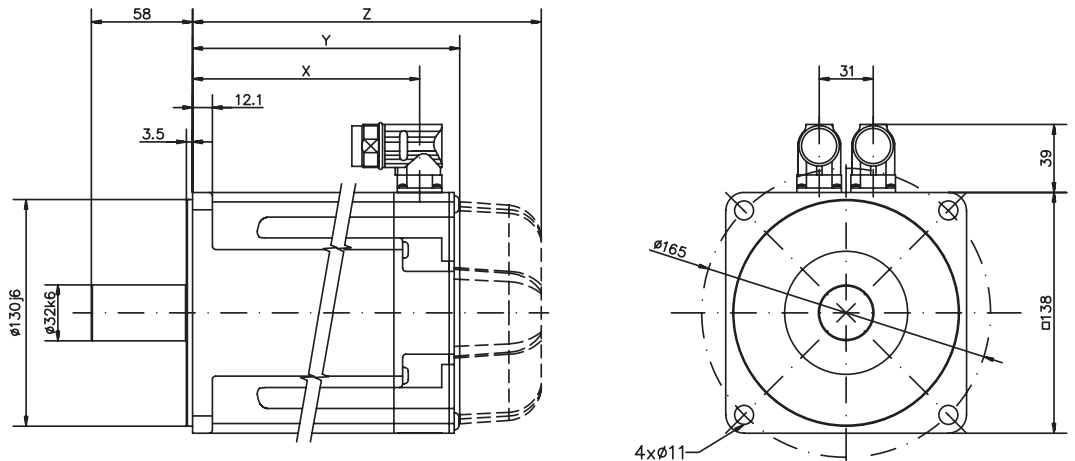

Model	X	Resolver/Comcoder		Encoder	
		Y	Z (brake)	Y	Z (brake)
AKM62	130.5	153.7	200.7	172.2	218.7
AKM63	155.5	178.7	225.7	197.2	224.7
AKM64	180.5	203.7	250.7	222.2	268.7
AKM65	205.5	228.7	275.7	247.2	294.7

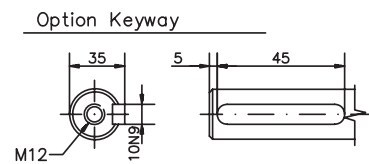

Radial-/axial forces at the shaft end

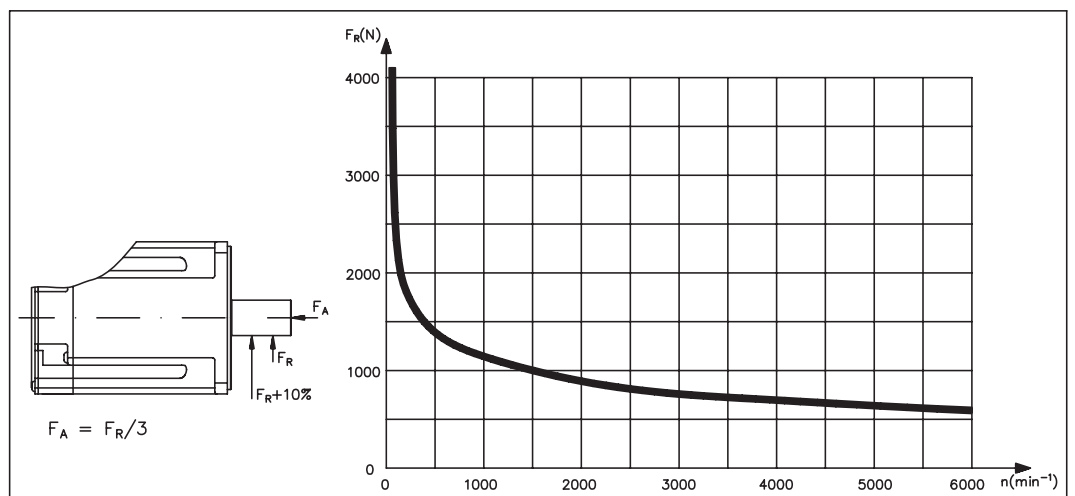

Performance curves

AKM62G

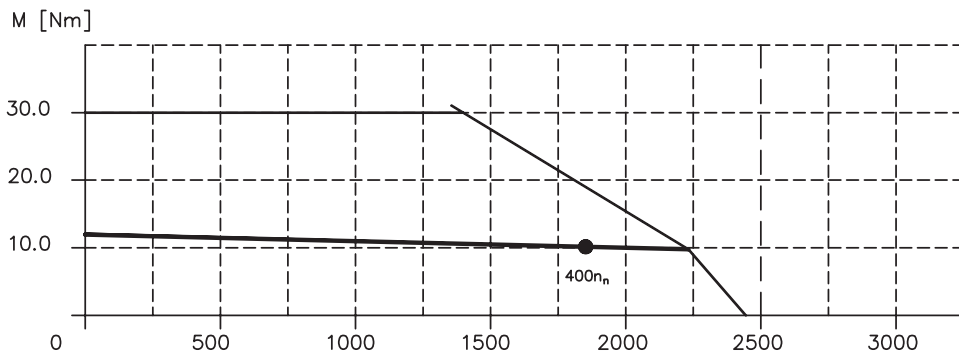

AKM62K

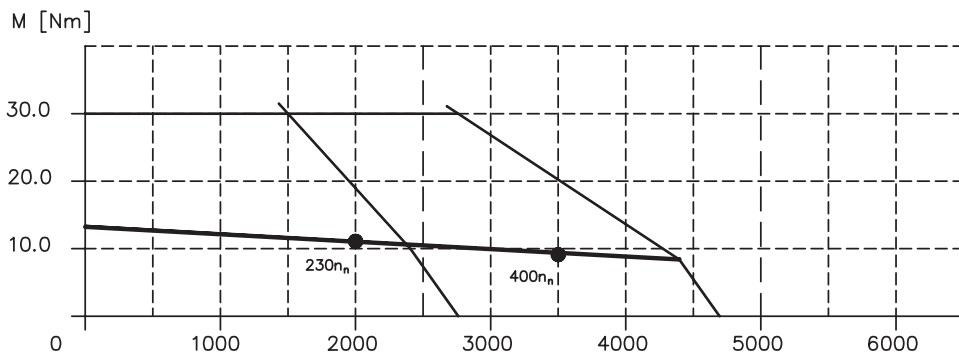

AKM62M

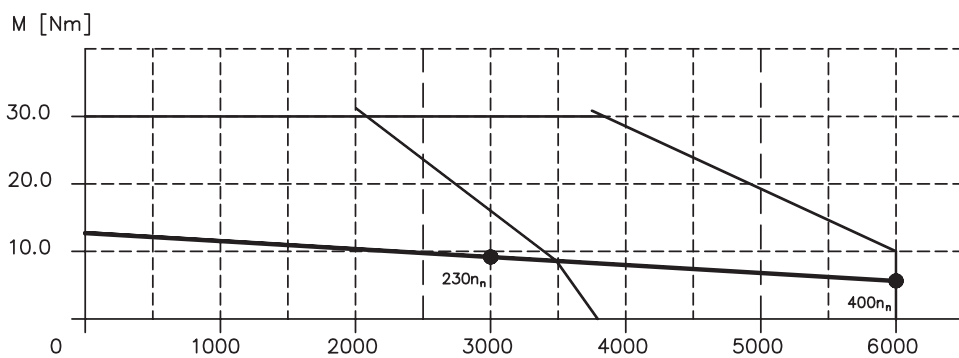

AKM62P

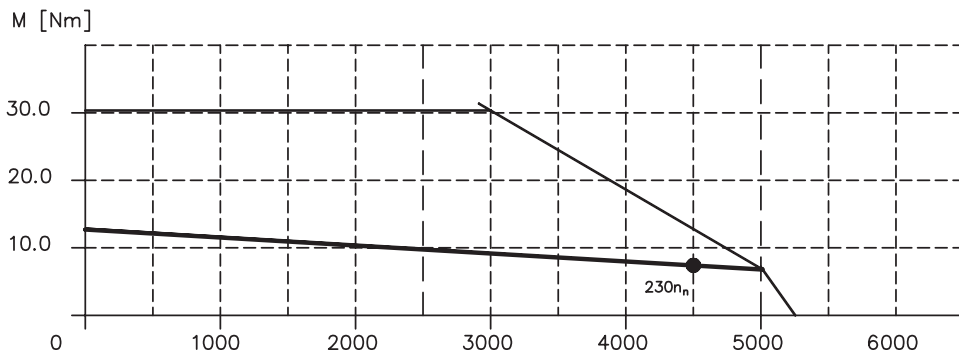

AKM63G

M [Nm]

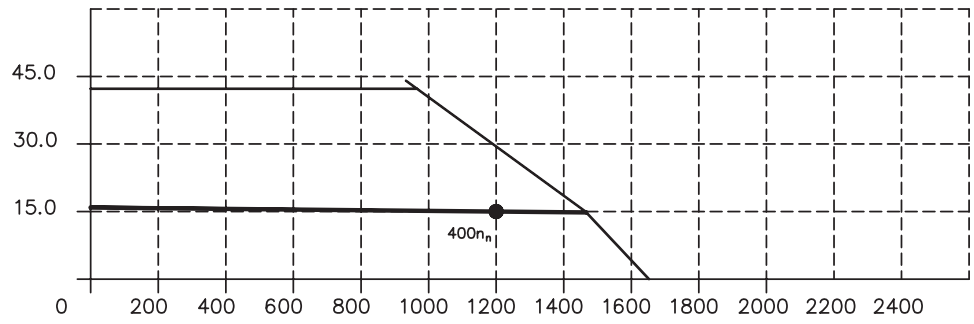

AKM63K

M [Nm]

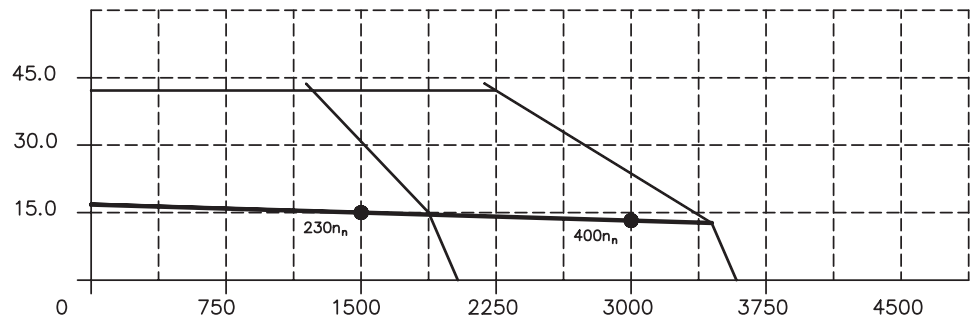

AKM63M

M [Nm]

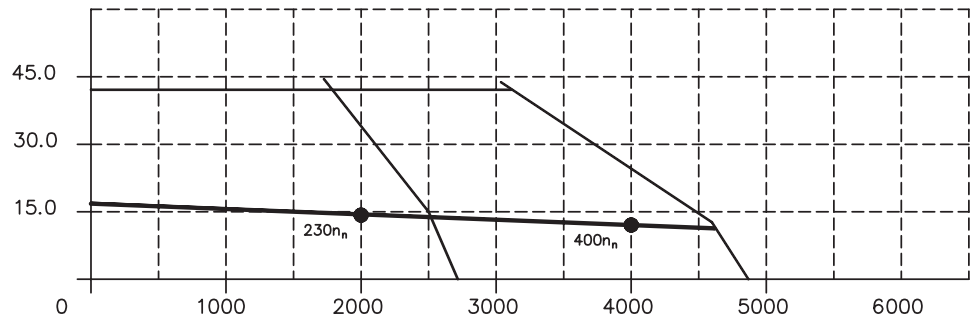

AKM63N

M [Nm]

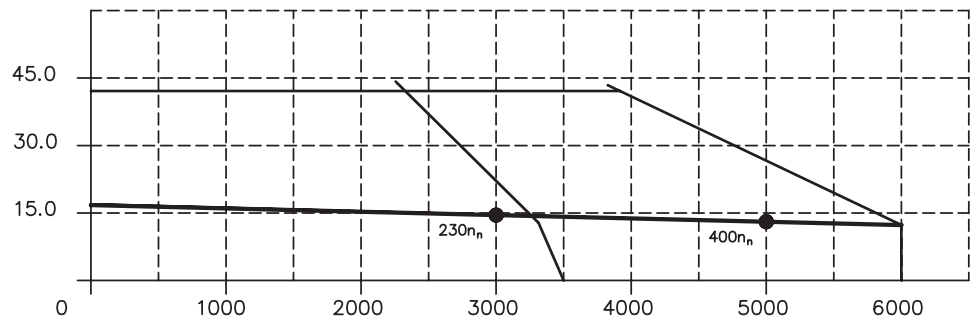

AKM64K

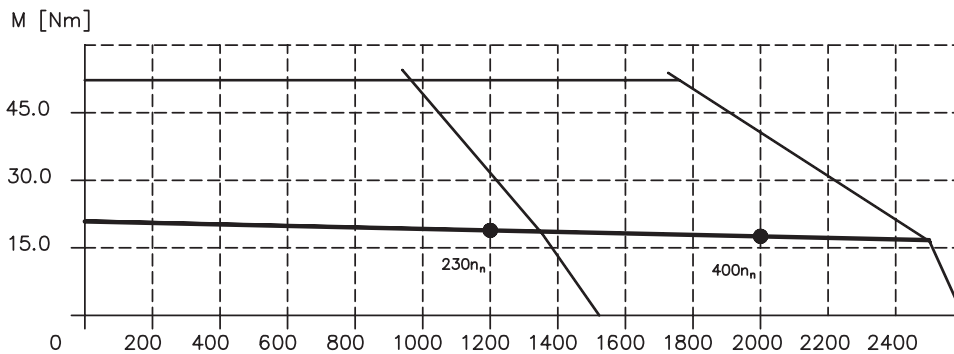

AKM64L

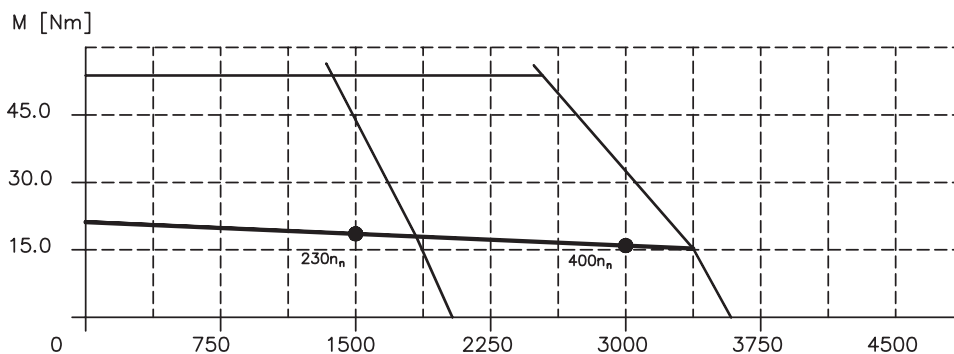

AKM64P

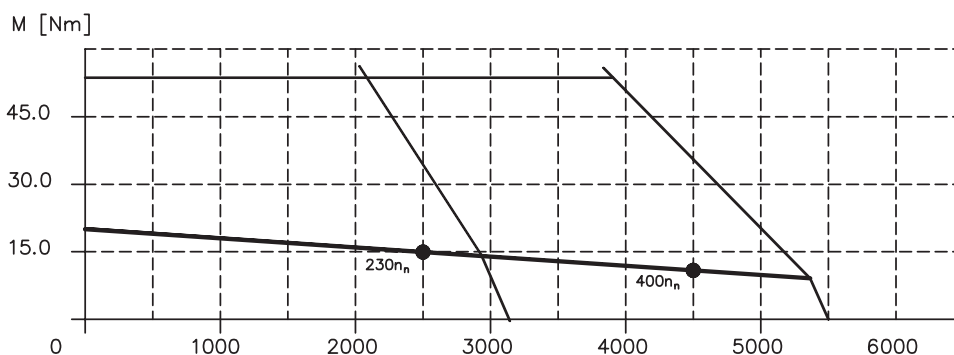

AKM65K

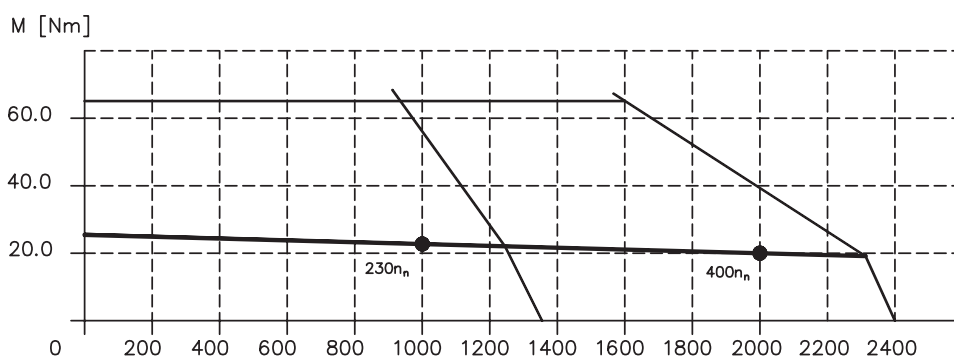

AKM65M

M [Nm]

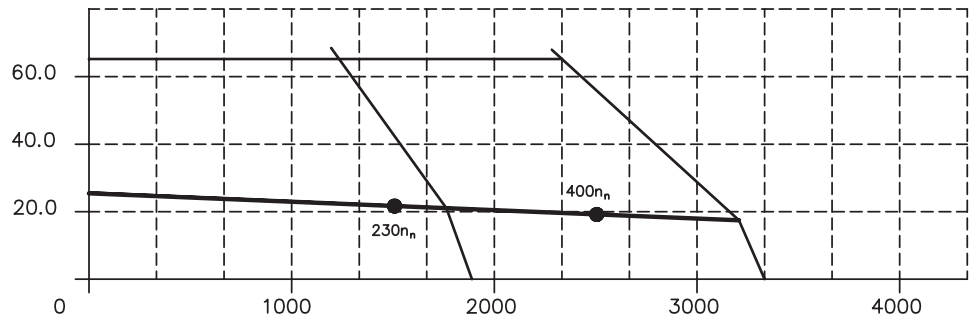

AKM65N

M [Nm]

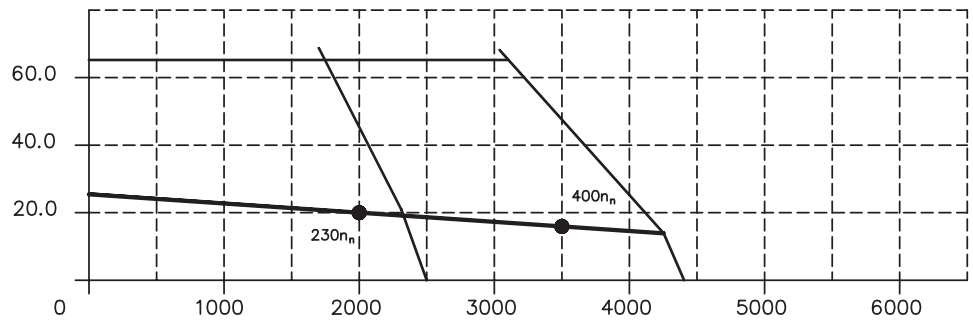

3.8

AKM7

Technical data

Data	Symbol [Unit]	AKM						
		72K	72M	72P	73M	73P	74L	74P
Electrical data								
Standstill torque*	M ₀ [Nm]	29,7	30,0	29,4	42,0	41,6	53,0	52,5
Standstill current	I _{0rms} [A]	9,3	13,0	18,7	13,6	19,5	12,9	18,5
max. Mains voltage	U _N [VAC]	480						
U = 75VDC	Rated speed	n _n [min ⁻¹]	—	—	—	—	—	—
	Rated torque*	M _n [Nm]	—	—	—	—	—	—
	Rated power	P _n [kW]	—	—	—	—	—	—
U _N = 115V	Rated speed	n _n [min ⁻¹]	—	—	—	—	—	—
	Rated torque*	M _n [Nm]	—	—	—	—	—	—
	Rated power	P _n [kW]	—	—	—	—	—	—
U _N = 230V	Rated speed	n _n [min ⁻¹]	—	—	1800	—	1300	—
	Rated torque*	M _n [Nm]	—	—	23,8	—	34,7	—
	Rated power	P _n [kW]	—	—	4,49	—	4,72	—
U _N = 400V	Rated speed	n _n [min ⁻¹]	1500	2000	3000	1500	2400	1200
	Rated torque*	M _n [Nm]	25,1	23,6	20,1	33,8	28,5	43,5
	Rated power	P _n [kW]	3,94	4,94	6,31	5,31	7,16	5,47
U _N = 480V	Rated speed	n _n [min ⁻¹]	1800	2500	3500	1800	2800	1400
	Rated torque*	M _n [Nm]	24,0	22,1	18,2	32,1	26,3	41,5
	Rated power	P _n [kW]	4,52	5,79	6,67	6,05	7,71	6,08
Peak current	I _{0max} [A]	27,8	38,9	56,1	40,8	58,6	38,7	55,5
Peak torque	M _{0max} [Nm]	79,2	79,7	78,5	113	111	143	142
Torque constant	K _{Trms} [Nm/A]	3,23	2,33	1,58	3,10	2,13	4,14	2,84
Voltage constant	K _{Ems} [mV/min]	208	150	102	200	137	266	183
Winding resistance Ph-Ph	R ₂₅ [Ω]	1,22	0,64	0,33	0,68	0,35	0,85	0,43
Winding inductance Ph-Ph	L [mH]	20,7	10,8	5,0	12,4	5,9	16,4	7,7
Mechanical data								
Rotor moment of inertia	J [kgcm ²]	65		92		120		
Pole number		10		10		10		
Static friction torque	M _R [Nm]	0,16		0,24		0,33		
Thermal time constant	t _{TH} [min]	46		53		60		
Weight standard	G [kg]	19,7		26,7		33,6		
Radial load permitted at shaft end @ 1000 min ⁻¹	F _R [N]	1300						
Axial load permitted at shaft end @ 1000 min ⁻¹	F _A [N]	500						

* reference flange Aluminium 457mm * 457mm * 12,7mm

Brake data

Data	Symbol [Unit]	Value
Holding torque @ 120°C	M _{BR} [Nm]	53
Operating voltage	U _{BR} [VDC]	24 ± 10 %
electrical power	P _{BR} [W]	35,6
Moment of inertia	J _{BR} [kgcm ²]	1,64
Release delay time	t _{BRH} [ms]	110
Application delay time	t _{BRL} [ms]	35
Weight of the brake	G _{BR} [kg]	2,1
Typical backlash	[°mech.]	0,2

Connections and cables

Data	AKM7
Power connection	4 + 4 poles, round, angular
Motorcable, shielded	4 x 2,5
Motor cable with control leads, shielded	4 x 2,5 + 2 x 1
Steueradern, geschirmt	4 x 1
Resolver connection	12 poles, round, angular
Resolver cable, shielded	4 x 2 x 0,25mm ²
Encoder connection (option)	17-polig, rund
Encoder cable, shielded	7 x 2 x 0,25mm ²

Dimensions (drawing in principle)

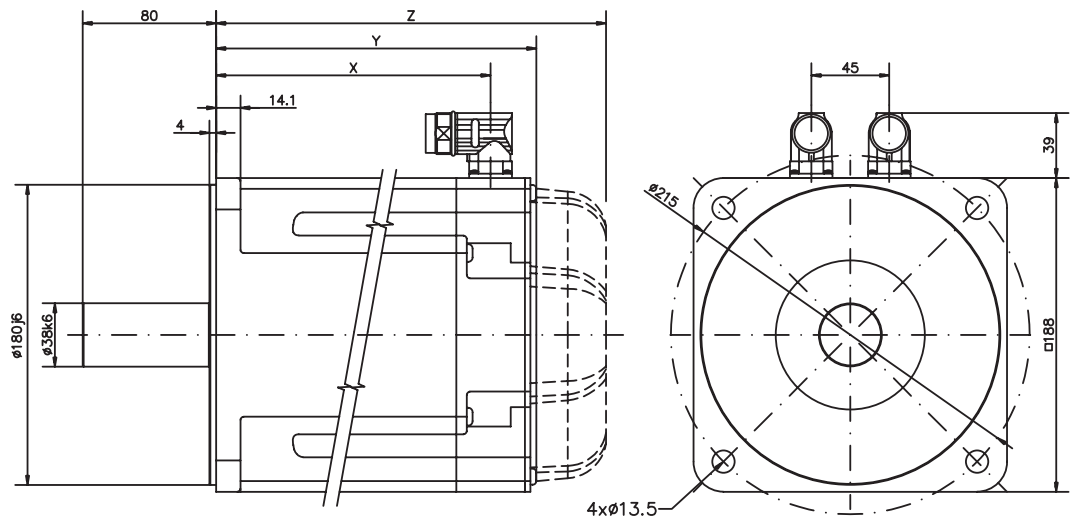

Model	X	Resolver/Comcoder		Encoder	
		Y	Z (brake)	Y	Z (brake)
AKM72	164.5	192.5	234.5	201.7	253.3
AKM73	198.5	226.5	268.5	235.7	287.3
AKM74	232.5	260.5	302.5	269.7	321.3

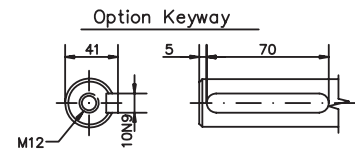

Radial-/axial forces at the shaft end

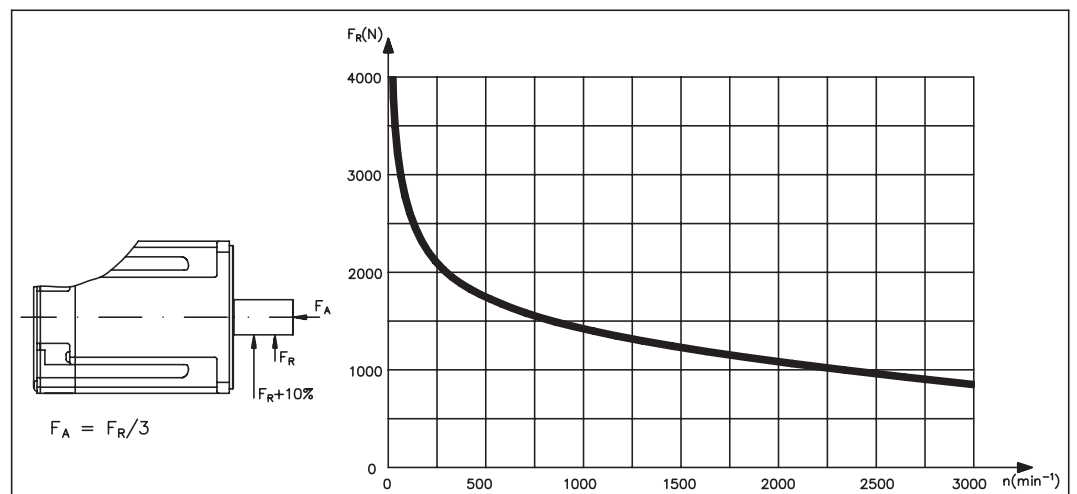

Performance curves

AKM72K

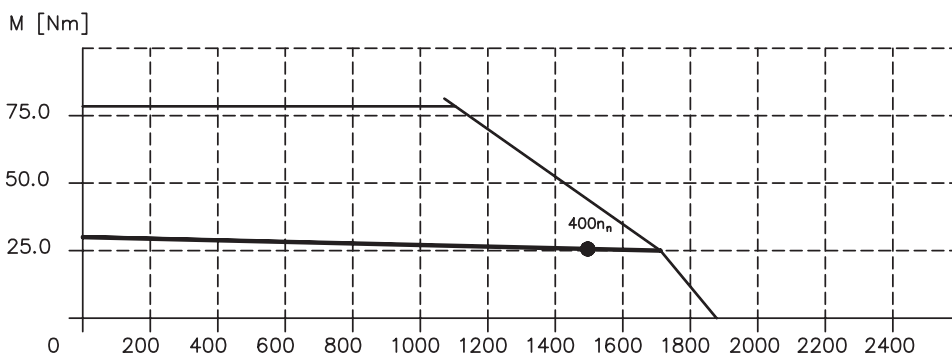

AKM72M

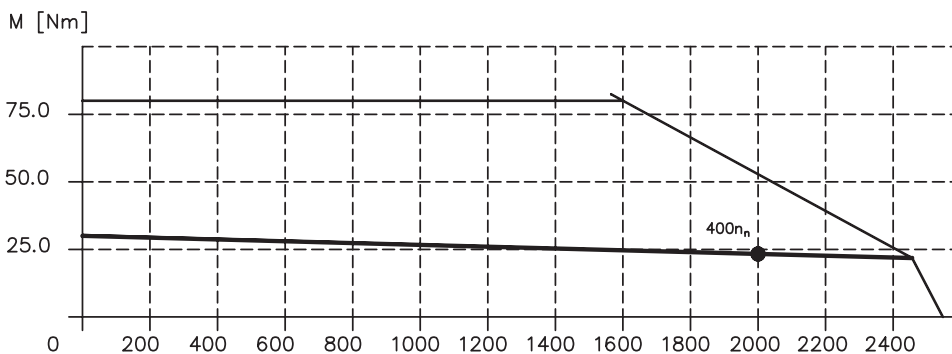

AKM72P

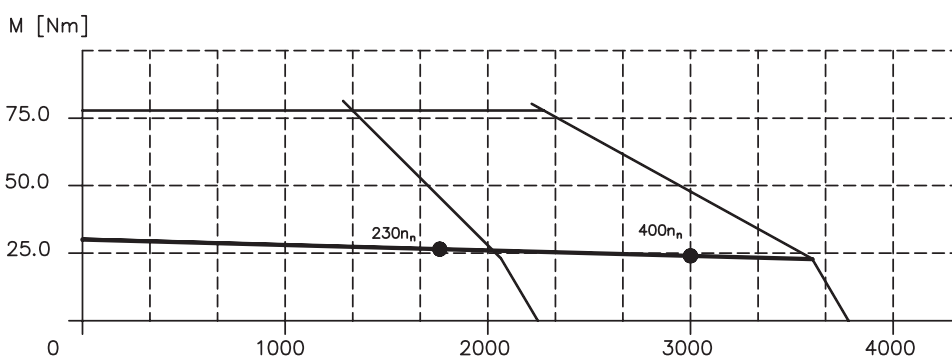

AKM73M

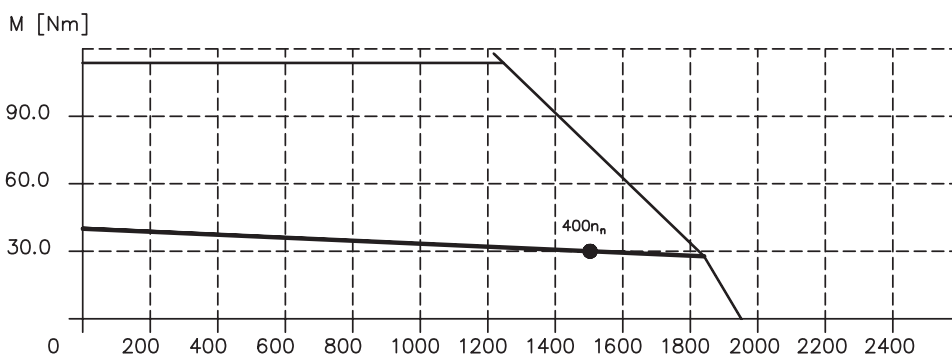

AKM73P

M [Nm]

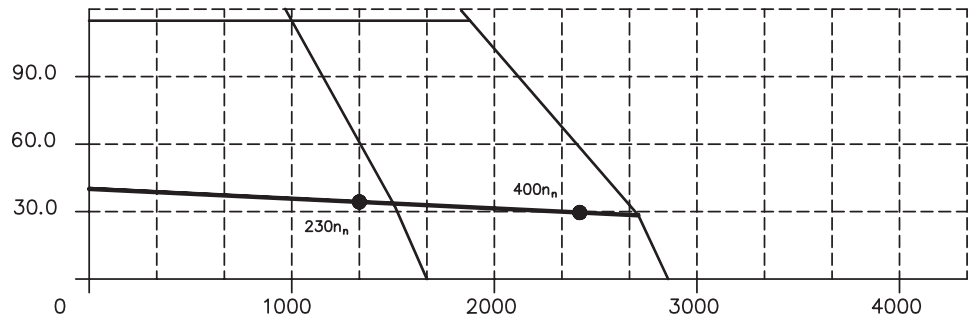

AKM74L

M [Nm]

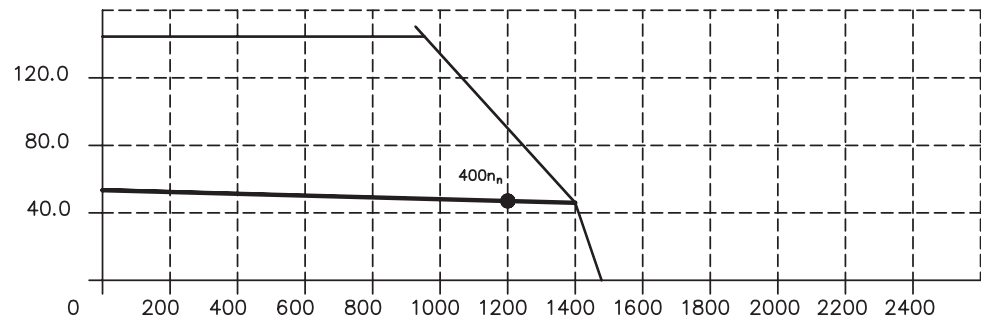

AKM74P

M [Nm]

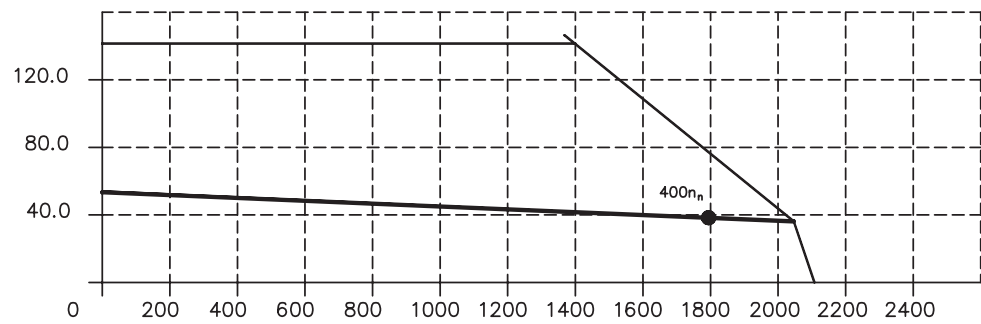

This page has been deliberately left blank.

4 Appendix

4.1 Assignment of RediMount gearhead mounts

Motor	RediMount	Flange length [mm]	Motor	RediMount	Flange length [mm]
AKM1xx-A	RM060-130	35,1	AKM4xx-C	RM075-124	42,9
AKM1xx-C	RM060-XXX	in preparation		RM090-124	44,1
AKM2xx-A	RM060-6	31,0		RM100-124	43,7
	RM075-6	in preparation		RM115-124	48,9
	RM090-6	62,7	AKM5xx-A	RM090-71	62,7
	RM100-6	in preparation		RM100-71	43,7
AKM2xx-C	RM060-17	31,0		RM115-71	48,9
	RM075-17	42,9		RM142-71	69,6
	RM090-17	44,1	RM180-71	91,4	
	RM100-17	62,7	AKM5xx-C	RM090-53	in preparation
RM115-17	48,9	RM100-53		in preparation	
AKM3xx-A	RM060-19	31,0		RM115-53	59,9
	RM075-19	42,9		RM142-53	in preparation
	RM090-19	44,1	RM180-53	in preparation	
	RM100-19	58,9	RM115-92	in preparation	
AKM3xx-C	RM060-XXX	in preparation	AKM6xx-A	RM142-92	81,5
	RM075-XXX	in preparation		RM180-92	91,4
	RM090-XXX	in preparation		RM220-92	69,5
	RM100-XXX	in preparation		RM142-114S	85,3
AKM4xx-A	RM075-40	42,9	AKM7xx-A	RM180-114	91,4
	RM090-40	44,1		RM220-114	69,6
	RM100-40	43,7			
	RM115-40	48,9			

These gearheads can be fitted to RediMount:

RM060: DT60, DTR60, DTRS60, DTRH60, NT23, NTP23, NT60, NTR23, UT006, UTR006, EQ23, EQ60

RM075: UT075, UTR075, UT090, UTR090

RM090: DT90, DTR90, DTRS90, DTRD90, DTRH90, NT34, NTP34, NT90, NTR34

RM100: UT010, UTR010, ET010, UT115, UTR115

RM115: DT115, DTR115, DTRS115, DTRD115, DTRH115, NT42, NTP42, NT115, NTR42

RM142: DT142, DTR142, DTRS142, DTRD142, DTRH142, NT142, UT014, UTR014, ET014

RM180: UT018, UTR018, ET018

RM220: UT220

You can find further information on Redimount and gearheads on our website.

4.2 Delivery package, transport, storage, maintenance, disposal

- Delivery package:** — Motor from the AKM series
 — Technical description (documentation), 1 copy per delivery
 — Motor package leaflet (short info)
- Transport:** — Climate category 2K3 to EN 50178
 Transport temperature -25...+70°C, max. 20K/hr change
 Transport humidity rel. humidity 5% - 95% , no condensation
 — only by qualified personnel
 — only in the manufacturer's original recyclable packaging
 — avoid shocks
 — if the packaging is damaged, check the motor for visible damage.
 Inform the carrier and, if appropriate, the manufacturer.
- Packaging:** — Cardboard packing with Instapak[®] foam cushion.
 You can return the plastic portion to the supplier or a certified disposal company. Ask us for addresses.

Motor type	Carton	Max.stacking height
AKM1	X	10
AKM2	X	10
AKM3	X	6
AKM4	X	6
AKM5	X	5
AKM6	X	1
AKM7	X	1

- Storage:** — Climate category 1K4 to EN 50178
 Storage temperature -25...+55°C, max. variation 20K/hr.
 Humidity rel. humidity 5% - 95%, no condensation
 — only in the manufacturer's original recyclable packaging
 — max. stacking height see table under Packaging
 — Storage time unlimited
- Maintenance:** — Only by qualified personnel
 — The ball bearings have a grease packing which is adequate for 20,000 hours of operation under normal conditions. The bearings should be replaced after 20,000 hours of operation under rated conditions.
 — Check the motor for bearing noise every 2500 operating hours, respectively each year. If any noises are heard, then the operation of the motor must stop, the bearings must be replaced.
 — Opening the motor invalidates the warranty.
- Cleaning:** — If the housing is dirty: clean with Isopropanol or similar.
do not immerse or spray
- Disposal:** — The disposal should be carried out by a certified disposal company.
 Ask us for addresses.

4.3 Removing faults

The following table is to be seen as a “First Aid” box. There can be a large number of different reasons for a fault, depending on the particular conditions in your system. The fault causes described below are mostly those which directly influence the motor. Peculiarities which show up in the control loop behaviour can usually be traced back to an error in the parameterization of the servo amplifier. The documentation for the servo amplifier and the setup software provides information on these matters.

For multi-axis systems there may be further hidden reasons for faults.

Our applications department can give you further help with your problems.

Fault	Possible cause	Measures to remove the cause of the fault
Motor doesn't rotate	<ul style="list-style-type: none"> — Servo-amplifier not enabled — Break in setpoint lead — Motor phases in wrong sequence — Brake not released — Drive is mechanically blocked 	<ul style="list-style-type: none"> — Supply ENABLE signal — Check setpoint lead — Correct the phase sequence — Check brake controls — Check mechanism
Motor runs away	<ul style="list-style-type: none"> — Motor phases in wrong sequence 	<ul style="list-style-type: none"> — Correct the phase sequence
Motor oscillates	<ul style="list-style-type: none"> — Break in the shielding of the resolver cable — amplifier gain too high 	<ul style="list-style-type: none"> — Replace resolver cable — use motor default values
Error message: brake	<ul style="list-style-type: none"> — Short-circuit in the supply voltage lead to the motor holding brake — Faulty motor holding brake 	<ul style="list-style-type: none"> — Remove the short-circuit — Replace motor
Error message: output stage fault	<ul style="list-style-type: none"> — Motor cable has short-circuit or earth short — Motor has short-circuit or earth short 	<ul style="list-style-type: none"> — Replace cable — Replace motor
Error message: resolver	<ul style="list-style-type: none"> — Resolver connector is not properly plugged in — Break in resolver cable, cable crushed or similar 	<ul style="list-style-type: none"> — Check connector — Check cables
Error message: motor temperature	<ul style="list-style-type: none"> — Motor thermostat has switched — Loose resolver connector or break in resolver cable 	<ul style="list-style-type: none"> — Wait until the motor has cooled down. Then investigate why the motor becomes so hot. — Check connector, replace resolver cable if necessary
Brake does not grip	<ul style="list-style-type: none"> — Required holding torque too high — Brake faulty — Motor shaft axially overloaded 	<ul style="list-style-type: none"> — Check the dimensioning — Replace motor — Check the axial load, reduce it. Replace motor, since the bearings have been damaged

4.4 Index

A	AKM1	24	P	Peak current	23
	AKM2	28		Pole numbers	10
	AKM3	33		Power derating	8
	AKM4	38		Protection class	9
	AKM5	44		Protective device	9
	AKM6	50	R	Radial force	9
	AKM7	56		Rated torque	23
	Ambient temperature	8		Resolver	10
	Axial force	9		Resolver cable	16
B	BISS	21		Rotor moment of inertia	23
	Break response times	23	S	Safety notes	6
C	ComCoder	20		Servo amplifier	8
	Connection method	10		Setup.	22
	Coupling	9		SFD	19
D	Delivery package.	62		Shielding	15
	Disposal	62		Standstill current	23
E	Earthing	15		Standstill torque	23
	Encoder	10		Storage.	62
F	Feedback unit	10		Storage humidity	62
G	Gearhead mount.	61		Storage temperature	62
	Ground symbol.	14		Storage time	62
H	Holding brake	10	T	Style	9
I	Insulation material class	9		Thermal time constant	23
M	Maintenance	62		Torque constant	23
	Manufacturer declaration	4		Transport.	62
	Model number	12	V	Ventilation	15
	Motor cable.	16		Vibration class	10
N	Nameplate	12		Voltage constant	23
O	Options.	11	W	Wiring	15

This page has been deliberately left blank.

Sales and Service

We are committed to quality customer service. In order to serve in the most effective way, please contact your local sales representative for assistance.
If you are unaware of your local sales representative, please contact us.

Europe

Visit the European Danaher Motion web site at www.DanaherMotion.net for Setup Software upgrades, application notes, technical publications and the most recent version of our product manuals.

Danaher Motion Customer Support - Europe

Internet www.DanaherMotion.net
E-Mail support@danahermotion.net
Phone: +49(0)203 - 99 79 - 0
Fax: +49(0)203 - 99 79 - 155

North America

Visit the North American Danaher Motion web site at www.DanaherMotion.com for Setup Software upgrades, application notes, technical publications and the most recent version of our product manuals.

Danaher Motion Customer Support North America

Internet www.DanaherMotion.com
E-Mail customer.support@danahermotion.com
Phone: (815) 226 - 2222
Fax: (815) 226 - 3148