

AKD™

Installation Manual



Edition: D, January 2011

Valid for Hardware Revision C

Part Number 903-200003-00

Original Document



Patents Pending

Keep all manuals as a product component during the life span of the product. Pass all manuals to future users and owners of the product.

KOLLMORGEN®

Record of Document Revisions:

Revision	Remarks
-, 11/2009	Beta launch version
-, 12/2009	Digital I/O corrections, several updates
A, 03/2010	CAN termination connector "optional", data dynamic brake updated, resolver signals renamed, CE certificate, X9 description updated, technical data completed
B, 06/2010	Several updates, typos, dimensions corrected, switch on/off timing diagrams
C, 07/2010	Switch on/off timing diagrams, typos, cover layout
D, 01/2011	Hardware Revision C, STO certified, voltage level digital inputs changed

Hardware Revision (HR)

Hardware Revision	Firmware	WorkBench	Remarks
A	M_01-03-zz-zzz	1.3.0.zzzzz	Start revision
C	≥ M_01-03-00-011	1.3.0.zzzzz	STO certified

EnDat is a registered trademark of Dr. Johannes Heidenhain GmbH
EtherCAT is a registered trademark of EtherCAT Technology Group
HIPERFACE is a registered trademark of Max Stegmann GmbH
WINDOWS is a registered trademark of Microsoft Corporation
AKD is a registered trademark of Kollmorgen™ Corporation

Current patents:

US Patent 5,646,496 (used in control card R/D and 1 Vp-p feedback interface)

US Patent 5,162,798 (used in control card R/D)

US Patent 6,118,241 (used in control card simple dynamic braking)

Technical changes which improve the performance of the device may be made without prior notice!

Printed in the United States of America

This document is the intellectual property of Kollmorgen™. All rights reserved. No part of this work may be reproduced in any form (by photocopying, microfilm or any other method) or stored, processed, copied or distributed by electronic means without the written permission of Kollmorgen™.

Table of Contents

1 General	9
1.1 About this Manual	10
1.2 Target Group	10
1.3 Using the PDF Format	10
1.4 Abbreviations used	11
1.5 Symbols used	12
1.6 Standards Used	13
2 Safety	14
2.1 Safety Instructions	15
2.2 Use as Directed	16
2.3 Prohibited Use	16
3 Approvals	17
3.1 Conformance with UL/cUL	18
3.1.1 UL Markings	18
3.2 CE Conformance	20
3.2.1 European Directives and Standards for the machine builder	21
3.2.2 EC Declaration of Conformity	22
3.3 Safe Torque Off (STO)	23
4 Handling	24
4.1 Transport	25
4.2 Packaging	25
4.3 Storage	25
4.4 Maintenance and Cleaning	26
4.5 Uninstalling	26
4.6 Repair and Disposal	26
5 Package	27
5.1 Package Supplied	28
5.2 Nameplate	28
5.3 Part number scheme	29
6 Technical description and data	30
6.1 The AKD Family of Digital Drives	31
6.2 Ambient Conditions, Ventilation, and Mounting Position	33
6.3 Mechanical Data	33
6.4 Inputs/Outputs	33
6.5 Electrical Data AKD-xzzz06	34
6.6 Electrical Data AKD-xzzz07	35
6.7 Performance Data	36
6.8 Recommended tightening torques	36
6.9 Fusing	37
6.9.1 External Power Supply fusing	37
6.9.2 External 24 V supply fusing	37
6.9.3 External Brake Resistor fusing	37

6.10	Connectors.....	38
6.10.1	AKD-xzzz06 Types (120V to 240V Mains Voltage Supply).....	38
6.10.2	AKD-xzzz07 Types (240V to 480V Mains Voltage Supply).....	38
6.11	Cable and Wire Requirements.....	39
6.11.1	General.....	39
6.11.2	Cable Cross Sections and Requirements.....	39
6.12	LED display.....	40
6.13	Grounding System.....	40
6.14	Dynamic Braking.....	41
6.14.1	Brake Chopper.....	41
6.14.1.1	Functional description.....	41
6.14.1.2	Technical Data for AKD-xzzz06.....	42
6.14.1.3	Technical Data for AKD-xzzz07.....	43
6.15	Switch-on and Switch-off Behavior.....	44
6.15.1	Switch-on behavior in standard operation.....	45
6.15.2	Switch-off behavior.....	46
6.15.2.1	Switch-off behavior using the DRV.DIS command.....	46
6.15.2.2	Switch-off behavior using a digital input (controlled stop).....	47
6.15.2.3	Switch-off behavior using HW Enable input (uncontrolled stop).....	47
6.15.2.4	Switch-off behavior in the event of a fault.....	48
6.16	Stop-/Emergency Stop- Standards.....	51
6.16.1	Stop: Standards.....	51
6.16.2	Emergency Stop: Standards.....	52
6.17	Safe Torque Off (STO).....	53
6.17.1	Safety characteristic data.....	53
6.17.2	Safety instructions.....	54
6.17.3	Use as directed.....	54
6.17.4	Prohibited Use.....	54
6.17.5	Technical data and pinning.....	55
6.17.6	Enclosure.....	55
6.17.7	Wiring.....	55
6.17.8	Functional description.....	56
6.17.8.1	Signal diagram (sequence).....	56
6.17.8.2	Control circuit (example).....	57
6.17.8.3	Functional test.....	58
6.17.8.4	Mains supply circuit (example).....	58
6.18	Shock-hazard Protection.....	59
6.18.1	Leakage Current.....	59
6.18.2	Residual Current Protective Device (RCD).....	59
6.18.3	Isolating Transformers.....	59
7	Mechanical Installation.....	60
7.1	Safety Instructions.....	61
7.2	Guide to Mechanical Installation.....	61
7.3	Control Cabinet Layout AKD-xzzz06.....	62
7.4	Control Cabinet Layout AKD-xzzz07.....	63

7.5	Dimensions, AKD-x00306 to x00606.....	64
7.6	Dimensions, AKD-x01206.....	65
7.7	Dimensions, AKD-x02406.....	66
7.8	Dimensions, AKDx00307 to 01207.....	67
7.9	Dimensions, AKDx02407.....	68
8	Electrical Installation.....	69
8.1	Safety Instructions.....	70
8.2	Guide to electrical installation.....	71
8.3	Wiring.....	72
8.4	Components of a servosystem.....	73
8.5	Connector Assignments, AKD-x00306 to x00606.....	75
8.6	Connector Assignments, AKD-x01206.....	75
8.7	Connector Assignments, AKD-x02406 and AKD-xzzz07.....	76
8.8	Connection Diagram, AKD-x00306 to x00606.....	77
8.9	Connection Diagram, AKD-x01206.....	78
8.10	Connection Diagram, AKD-x02406 and AKD-xzzz07.....	79
8.11	EMI Noise Reduction.....	80
8.11.1	Recommendations for EMI Noise Reduction.....	80
8.11.2	Shielding with External Shielding Busbar.....	81
8.11.2.1	Shielding Concept.....	81
8.11.2.2	Shielding Busbar.....	82
8.11.3	Shielding Connection to the Drive.....	83
8.11.3.1	Grounding Plates.....	83
8.11.3.2	Shield connection clamps.....	83
8.11.3.3	Motor Connector X2 with shielding connection.....	83
8.12	Electrical Supply Connection.....	84
8.12.1	Connection to Various Mains Supply Networks AKD-xzzz06 (120V to 240V).....	84
8.12.2	Connection to Various Mains Supply Networks AKD-xzzz07 (240V to 480V).....	85
8.12.3	24 V Auxiliary Supply (X1).....	86
8.12.4	Mains Supply Connection (X3, X4).....	87
8.12.4.1	Three Phase connection (all AKD types).....	87
8.12.4.2	Single phase connection (AKD-xzzz06 only).....	88
8.12.5	External Brake Resistor (X3).....	89
8.12.6	DC Bus Link (X3).....	90
8.13	Motor Connection.....	91
8.13.1	Motor Power (X2).....	92
8.13.1.1	Cable Length \leq 25 m.....	92
8.13.1.2	Cable length $>$ 25 m.....	92
8.13.2	Motor Holding Brake (X2).....	93
8.14	Feedback Connection.....	94
8.14.1	Feedback Connector (X10).....	95
8.14.2	Resolver.....	96
8.14.3	SFD.....	97
8.14.4	Encoder with BiSS.....	98
8.14.5	Sine Encoder with EnDat 2.1.....	99

8.14.6	Encoder with EnDat 2.2	100
8.14.7	Sine Encoder with Hiperface	101
8.14.8	Sine Encoder	102
8.14.9	Incremental Encoder	103
8.15	Electronic gearing, Master-slave operation	104
8.15.1	Technical characteristics and pinout	104
8.15.1.1	Connector X7 Input	104
8.15.1.2	Connector X9 Input	105
8.15.1.3	Connector X9 Output	105
8.15.2	Command encoder signal connection	106
8.15.2.1	Incremental encoder input 5 V (X9)	106
8.15.2.2	Incremental encoder input 24 V (X7)	106
8.15.2.3	Emulated Encoder Output (EEO) - A quad B (X9)	107
8.15.3	Pulse / Direction signal connection	108
8.15.3.1	Pulse / Direction input 5 V (X9)	108
8.15.3.2	Pulse / Direction input 24 V (X7)	108
8.15.4	Up / Down signal connection	109
8.15.4.1	Up / Down input 5 V (X9)	109
8.15.4.2	Up / Down input 24 V (X7)	109
8.15.5	Master-Slave Control	109
8.16	I/O Connection	110
8.16.1	I/O Connectors (X7 and X8)	110
8.16.2	Analog Input (X8)	111
8.16.3	Analog Output (X8)	112
8.16.4	Digital Inputs (X7/X8)	113
8.16.4.1	Digital Inputs 1 and 2	115
8.16.4.2	Digital Inputs 3 to 7	115
8.16.4.3	Digital Input 8 (ENABLE)	115
8.16.5	Digital Outputs (X7/X8)	116
8.16.5.1	Digital Outputs 1 and 2	116
8.16.5.2	FAULT relay contacts	117
8.17	Service Interface (X11)	118
8.17.1	Possible Network Configurations	118
8.17.2	Setting the IP Address with Rotary Switches	119
8.18	CANbus Interface (X12/X13)	120
8.18.1	Transmission Rate for CANbus	120
8.18.2	Node Address for CANbus	121
8.18.3	CANbus Termination	121
8.18.4	CANbus Cable	121
8.18.5	CAN Bus Wiring	122
8.19	Motion Bus Interface (X5/X6)	123
8.19.1	Pinout X5/X6	123
8.19.2	Optional Motion Bus Protocols	123
8.19.3	EtherCAT	124
8.19.4	SynqNet (in process)	124

8.19.5	Motion Busses in Process.....	124
8.19.5.1	PROFINET CBA/RT/IRT (in process).....	124
8.19.5.2	SERCOS III (in process).....	124
8.19.5.3	Ethernet IP (A-B, in process).....	124
8.19.5.4	Powerlink (in process).....	124
8.19.5.5	Modbus TCP/IP (in process).....	124
9	Setup.....	125
9.1	Safety Instructions.....	126
9.2	Setup software (WorkBench).....	127
9.2.1	Use as directed.....	127
9.2.2	Software description.....	128
9.2.3	Hardware requirements.....	128
9.2.4	Operating systems.....	128
9.2.5	Installation under WINDOWS 2000/XP/VISTA/7.....	129
9.3	Basic Drive Test.....	130
9.3.1	Unpacking, Mounting, and Wiring the Drive.....	130
9.3.2	Minimum Wiring for Drive Test without Load.....	130
9.3.3	Testing Procedure.....	131
9.3.3.1	Confirm Connections.....	131
9.3.3.2	Install and Start WorkBench.....	131
9.3.3.3	Set Drive IP Address in WorkBench.....	131
9.3.3.4	Enable the Drive Using the Setup Wizard.....	132
9.4	Fault and Warning Messages.....	133
9.5	Troubleshooting the AKD.....	139
10	Option Cards.....	140
11	Order Codes.....	141
11.1	Cables, brake resistors, filters, chokes.....	141
11.2	Drives.....	141
11.3	Mating connectors.....	141
11.3.1	AKD-xzzz06.....	141
11.3.2	AKD-xzzz07.....	141
12	Index.....	143

This page intentionally left blank.

1 General

1.1 About this Manual	10
1.2 Target Group	10
1.3 Using the PDF Format	10
1.4 Abbreviations used	11
1.5 Symbols used	12
1.6 Standards Used	13

1.1 About this Manual

This manual, *AKD Installation Manual*, describes the AKD series of digital drives and includes information needed to safely install an AKD. A digital version of this manual (pdf format) is available on the CD-ROM included with your drive. Manual updates can be downloaded from the Kollmorgen™ website (www.kollmorgen.com).

This document fulfills all requirements for an "Instructions Manual" under the EC Machinery Directive (2006/42/EC).

Additional documents on the accompanying CD-ROM include the following:

- *AKD Quick Start* (also provided in hard copy). This guide provides instructions for basic drive setup and connection to a network.
- *AKD Users Manual*. This manual describes how to use your drive in common applications. It also provides tips for maximizing your system performance with the AKD.
- *AKD Parameter and Command Reference Guide*. This guide provides documentation for the parameters and commands used to program the AKD.

1.2 Target Group

This manual addresses personnel with the following qualifications:

- Transport: only by personnel with knowledge of handling electrostatically sensitive components.
- Unpacking: only by electrically qualified personnel.
- Installation: only by electrically qualified personnel.
- Basic tests: only by qualified personnel with extensive knowledge of electrical engineering and drive technology

The qualified personnel must know and observe the following standards:

- ISO 12100, IEC 60364 and IEC 60664
- National accident prevention regulations

▲ WARNING During operation, hazards exist that can cause death, severe injury, or material damage. To safely operate the AKD, you must follow all safety instructions in this manual. The operator of systems using the AKD must require that all personnel who work with the drive read and understand the manual before using the drive.

1.3 Using the PDF Format

This document includes several features for ease of navigation



Cross References	Table of contents and index include active cross references.
Table of contents and index	Lines are active cross references. Click on the line and the appropriate page is accessed.
Page/chapter numbers in the text	Page/chapter numbers with cross references are active links.

1.4 Abbreviations used











Abbreviation	Meaning
AGND	Analog ground
CE	Communauté Européenne
COM	Serial interface for a personal computer
DCOMx	Communication line for digital inputs (with x=7 or 8)
Disk	Magnetic storage (diskette, hard disk)
EEPROM	Electrically erasable programmable memory
EMC	Electromagnetic compatibility
F-SMA	Fiber optic cable connector according to IEC 60874-2
LED	Light-emitting diode
LSB	Low significant byte (or bit)
MSB	Main significant byte (or bit)
NI	Zero pulse
PC	Personal computer
PE	Protective earth
PLC	Programmable logic control
PWM	Pulse-width modulation
RAM	Random access memory (volatile memory)
$R_{\text{Brake}}/R_{\text{B}}$	Brake resistor (also called a regen resistor)
RBext	External brake resistor
RBint	Internal brake resistor
RCD	Residual current device
RES	Resolver
ROD	Incremental encoder (A quad B)
S1	Continuous operation
STO	Safe torque off
Vac	Volts, alternating current
Vdc	Volts, direct current

1.5 Symbols used

Warning Symbols

Symbol	Indication
 DANGER	Indicates a hazardous situation which, if not avoided, will result in death or serious injury.
 WARNING	Indicates a hazardous situation which, if not avoided, could result in death or serious injury.
 CAUTION	Indicates a hazardous situation which, if not avoided, could result in minor or moderate injury.
NOTICE	Indicates situations which, if not avoided, could result in property damage.
NOTE	This is not a safety symbol. This symbol indicates important notes.

Drawing symbols

Symbol	Description	Symbol	Description
	Signal ground		Diode
	Chassis ground		Relays
	Protective earth		Relays switch off delayed
	Resistor		Normal open contact
	Fuse		Normal closed contact

1.6 Standards Used

Standard	Content
ISO 4762	Hexagon socket head cap screws
ISO 11898	Road vehicles — Controller area network (CAN)
ISO 12100	Safety of machinery: Basic concepts, general principles for design
ISO 13849	Safety of machinery: Safety-related parts of control systems
IEC 60085	Electrical insulation - Thermal evaluation and designation Maintenance
IEC 60204	Safety of Machinery: Electrical equipment of machinery
IEC 60364	Low-voltage electrical installations
IEC 60439	Low-Voltage Switchgear and Controlgear Assemblies
IEC 60529	International protection rating (IP code)
IEC 60664	Insulation coordination for equipment within low-voltage systems
IEC 60721	Classification of environmental conditions
IEC 61000	Electromagnetic compatibility (EMC)
IEC 61131	Programmable controllers
IEC 61491	Electrical equipment of industrial machines – Serial data link for real-time communications between controls and drives.
IEC 61508	Functional safety of electrical/electronic/programmable electronic safety-related systems
IEC 61800	Adjustable speed electrical power drive systems
IEC 62061	Functional safety of electrical/electronic/programmable electronic safety-related systems
IEC 62079	Preparation of instructions - Structuring, content and presentation
ANSI Z535	Product safety (symbols, colors, information)
UL 840	UL Standard for Safety for Insulation Coordination Including Clearances and Creepage Distances for Electrical Equipment
UL 508C	UL Standard for Safety Power Conversion Equipment

ANSI - American National Standard Institute, Inc.

IEC - International Electrotechnical Commission

ISO - International Organization for Standardization

UL - Underwriters Laboratories

2 Safety

2.1 Safety Instructions	15
2.2 Use as Directed	16
2.3 Prohibited Use	16

2.1 Safety Instructions

<p>⚠ DANGER</p>	<p>During operation, hazards exist that can cause death, severe injury, or material damage. Do not open or touch the equipment during operation. Keep all covers and cabinet doors closed during operation. Only properly qualified persons may handle the equipment during installation and commissioning .</p> <ul style="list-style-type: none"> • During operation, drives may have uncovered live components, depending on their level of enclosure protection. • Control and power connections may be live, even though the motor is not rotating. • Drives may have hot surfaces during operation. The heat sink can reach temperatures above 80°C.
<p>⚠ WARNING</p>	<p>The danger of electrical arcing is present. Electrical arcing can damage contacts and injure personnel. Never undo any electrical connections to the drive while it is live. Wait at least 7 minutes after disconnecting the drive from the main supply power before touching potentially live sections of the equipment (such as contacts) or removing any connections. Capacitors can have dangerous voltages present up to seven minutes after switching off the supply power. Always measure the voltage in the DC bus link and wait until the voltage is below 40 V before handling components.</p>
<p>⚠ CAUTION</p>	<p>Incorrect handling of the drive can lead to personnel injury or material damage. Read this documentation before installing and commissioning the drive. It is vital that you keep to the technical data and information on connection requirements (nameplate and documentation). Only properly qualified personnel may perform activities such as transport, installation, commissioning, and maintenance. Properly qualified persons are those who are familiar with the transport, assembly, installation, commissioning and operation of the product, and who have the appropriate qualifications for their job. The qualified personnel must know and observe the following standards:</p> <ul style="list-style-type: none"> • IEC 60364 and IEC 60664 • national accident prevention regulations
<p>⚠ CAUTION</p>	<p>The manufacturer of the machine must produce a hazard analysis for the machine and take appropriate measures to ensure that unforeseen movements do not result in personnel injury or material damage.</p>
<p>⚠ CAUTION</p>	<p>It is not allowed to modify this device without permission by the manufacturer.</p>
<p>NOTICE</p>	<p>Check the Hardware Revision Number of the product (see product label). This revision number must match the Hardware Revision Number on the cover page of the manual.</p>
<p>NOTICE</p>	<p>The drives contain electrostatically sensitive components which may be damaged by incorrect handling. Electrostatically discharge your body before touching the drive. Avoid contact with highly insulating materials (artificial fabrics, plastic film etc.). Place the drive on a conductive surface.</p>

2.2 Use as Directed

Drives are components that are built into electrical plants or machines and can only be operated as integral components of these plants or machines. The manufacturer of the machine used with a drive must generate a hazard analysis for the machine and take appropriate measures to ensure that unforeseen movements cannot cause personnel injury or property damage.

Cabinet and wiring

Drives must only be operated in a closed control cabinet suitable for the ambient conditions => p. 30. Ventilation or cooling may be necessary to keep the temperature within the cabinet below 40 °C.

Use only copper conductors for wiring. The conductor cross-sections can be derived from the standard IEC 60204 (alternatively for AWG cross-sections: NEC Table 310-16, 75 °C column).

Power supply

Drives in the AKD series can be supplied as follows:

- AKD-xzzz06: 1 or 3 phase industrial supply networks (not more than 200 kA symmetrical rated current at 120 V and 240 V).
- AKD-xzzz07: 3 phase industrial supply networks (not more than 200 kA symmetrical rated current at 240 V, 400 V and 480 V).

Connection to other voltage types of supply networks is possible with an additional isolating transformer (=> p. 84).

Periodic overvoltages between phases (L1, L2, L3) and the housing of the drive must not exceed 1000 V peak. In accordance with IEC 61800, voltage spikes (< 50 µs) between phases must not exceed 1000 V. Voltage spikes (< 50 µs) between a phase and the housing must not exceed 2000 V.

EMC filter measures for AKD-xzzz06 must be implemented by the user.

Motor voltage rating

The AKD family of drives is exclusively intended for driving suitable synchronous servomotors with closed-loop control of torque, speed, and/or position. The rated voltage of the motors must be at least as high as the DC bus link voltage divided by $\sqrt{2}$ produced by the drive ($U_{nMotor} \geq U_{DC} / \sqrt{2}$).

Safe torque off

Review the section "Use as Directed" in the STO chapter (=> p. 54) before using this safety function (according to ISO 13849 category 3).

2.3 Prohibited Use

Other use than that described in chapter "Use as directed" is not intended and can lead to personnel injuries and equipment damage. The drive may not be used with a machine that does not comply with appropriate national directives or standards. The use of the drive in the following environments is also prohibited:

- potentially explosive areas
- environments with corrosive and/or electrically conductive acids, alkaline solutions, oils, vapors, dusts
- ships or offshore applications

3 Approvals

3.1 Conformance with UL/cUL	18
3.2 CE Conformance.....	20
3.3 Safe Torque Off (STO).....	23

3.1 Conformance with UL/cUL

This drive is listed under UL (Underwriters Laboratories Inc.) file number **E141084** Vol.3 Sec.5.

USL, CNL – Power conversion equipment (NMMS, NMMS7) – Models AKD followed by B,P,S,M or F, followed by 003, 006, 012, and 024, followed by 06 or 07, followed by additional suffixes.

USL

Indicates Investigated to United States Standard for Power Conversion Equipment, UL 508C, Third Edition, Revised February 15, 2008.

CNL

Indicates investigation to Canadian Standard for Industrial Control Equipment, CAN/CSA - C22.2 No. 14-2005, Second Edition, Revised April 2008.

Note:

CNL = Canadian National Standards - Listed.

USL = United States Standards - Listed.

3.1.1 UL Markings

- These drives are open type adjustable frequency motor drives that provide variable speed control to motors and provides overload protection and current limit control.
- These devices are intended to be used in a pollution degree 2 environment.
- Identification of the terminals on the controller are coded so they may be identified in the instructions. The instructions shall identify power connections for power supply, load, control, and ground.
- Integral solid state short circuit protection does not provide branch circuit protection. Branch circuit protection must be provided in accordance with the National Electrical Code and any additional local codes, or the equivalent.
- This product is suitable for use on a circuit capable of delivering not more than 200,000 rms symmetrical amperes, 240 V (AKD-xzzz06) / 480 V (AKD-xzzz07) volts maximum, when protected by " Fuses", or equivalent.
- The following fuse types are recommended:

Model	Fuse class	Rating	Max. Fuse Rating
AKD-x00306	J	600 Vac, 200 kA	10 A
AKD-x00606	J	600 Vac, 200 kA	15 A
AKD-x01206	J	600 Vac, 200 kA	15 A
AKD-x02406	J	600 Vac, 200 kA	30 A
AKD-x00307	J	600 Vac, 200 kA	6 A
AKD-x00607	J	600 Vac, 200 kA	10 A
AKD-x01207	J	600 Vac, 200 kA	15 A
AKD-x02407	J	600 Vac, 200 kA	30 A

- These drives provide solid state motor overload protection at 125% of the rated FLA Current.
- Use minimum 75°C copper wire.

- The following table illustrates the torque requirements for the field wiring connectors:

Model	Mains Connector	Motor Phase Connector	24 Vdc Input Connector
AKD-x00306	5-7 in-lbs	5-7 in-lbs	4 in-lbs
AKD-x00606	5-7 in-lbs	5-7 in-lbs	4 in-lbs
AKD-x01206	5-7 in-lbs	7 in-lbs	4 in-lbs
AKD-x02406	7 in-lbs	7 in-lbs	4 in-lbs
AKD-x00307	7 in-lbs	7 in-lbs	4 in-lbs
AKD-x00607	7 in-lbs	7 in-lbs	4 in-lbs
AKD-x01207	7 in-lbs	7 in-lbs	4 in-lbs
AKD-x02407	7 in-lbs	7 in-lbs	4 in-lbs

- Maximum surrounding air temperature of 40°C” or equivalent.

3.2 CE Conformance

Conformance with the EC EMC Directive 2004/108/EC and the Low Voltage Directive 2006/95/EC is mandatory for the supply of drives within the European Community.

The drives have been tested by an authorized testing laboratory in a defined configuration, using the system components that are described in this documentation. Any divergence from the configuration and installation described in this documentation means that the user will be responsible for carrying out new measurements to ensure conformance with regulatory requirements.

AKD-xzzz06

NOTICE

AKD-xzzz06 drives do not have integrated EMC filters. These drives can cause high-frequency interferences and may require measures for interference suppression (such as additional external EMC filters).

With external EMC filters for noise emission the drives meet the noise immunity requirements of the second environmental category (industrial environment) to a product of the category C2 (motor cable < 10 m).

With a motor cable length of 10 m or longer and external EMC filters, the drive meets the requirement of category C3.

AKD-xzzz07

NOTE

AKD-xzzz07 drives have integrated EMC filters.

The drive meets the noise immunity requirements to the 2nd environmental category (industrial environment). For noise emission the drive meets the requirement to a product of the Category C2 (motor cable < 10 m).

With a motor cable length of 10 m or longer, the servo drive meets the requirement to the Category C3.

3.2.1 European Directives and Standards for the machine builder

Drives are components that are intended to be incorporated into electrical plant and machines for industrial use. When the drives are built into machines or plant, the drive must not be used until it has been established that the machine or equipment fulfills the requirements of the

- EC Machinery Directive (2006/42/EC)
- EC EMC Directive (2004/108/EC)
- EC Low Voltage Directive (2006/95/EC)

Standards to be applied for conformance with the EC Machinery Directive (2006/42/EC)

- IEC 60204-1 (Safety and Electrical Equipment in Machines)
- ISO 12100 (Safety of Machines)

⚠ CAUTION The manufacturer of the machine must generate a hazard analysis for the machine, and must implement appropriate measures to ensure that unforeseen movements cannot cause injury or damage to any person or property.

Standards to be applied for conformance with the EC Low Voltage Directive(2006/95/EC)

- IEC 60204-1 (Safety and Electrical Equipment in Machines)
- IEC 60439-1 (Low-voltage switchgear and controlgear assemblies)

Standards to be applied for conformance with the EC EMC Directive (2004/108/EC)

- IEC 61000-6-1/2 (Interference Immunity in Residential & Industrial Areas)
- IEC 61000-6-3/4 (Interference Generation in Residential & Industrial Areas)

The manufacturer of the machine/plant is responsible for ensuring that it meets the limits required by the EMC regulations. Advice on the correct installation for EMC (such as shielding, grounding, treatment of connectors and cable layout) is shown in this manual.

NOTE The machine/plant manufacturer must check whether other standards or EC Directives must be applied to the machine/plant.

Kollmorgen™ only guarantees the conformance of the servosystem with the standards cited in this chapter if the components (motor, cables, chokes etc.) are those supplied by Kollmorgen™.

3.2.2 EC Declaration of Conformity

KOLLMORGEN

EC DECLARATION OF CONFORMITY

We, the company

Kollmorgen

Hereby in sole responsibility declare the conformity of the product series

AKD (Advanced Kollmorgen Drive) - models:

AKD-X 003 06-XX YY ZZZ	AKD-X 003 07-XX YY ZZZ
AKD-X 006 06-XX YY ZZZ	AKD-X 006 07-XX YY ZZZ
AKD-X 012 06-XX YY ZZZ	AKD-X 012 07-XX YY ZZZ
AKD-X 024 06-XX YY ZZZ	AKD-X 024 07-XX YY ZZZ

With the following standards:

- *EC Directive 2004/108/EC
Electromagnetic Compatibility
Standard EN 61800-3 (2004)*
- *LVD Directive 2006/95/EC
Electrical Safety: Low voltage directive
Standard IEC 61800-5-1 (2007)*

This Declaration does not contain any assurance of properties in the meaning of product liability.

The notes on safety and protection in the operating instructions must always be observed.

The above-mentioned company has the following technical documentation for examination:

- Proper operating instructions
- Setup Software
- Test certificates (for EU authority only)
- Other technical documentation (for EU authority only)

Signed:



Alex Matskin November 17, 2009
Validation and compliance team leader

Title:

21C Yagja Kapayim • P.O.B. 3919, Petach Tikva 49130, Israel • Tel: +972.3.9273800 • www.danahermotion.com

A DANAHER MOTION COMPANY

3.3 Safe Torque Off (STO)

An additional digital input (STO) releases the power output stage of the drive as long as a 24 V signal is applied to this input. If the STO input goes open-circuit, then power will no longer be supplied to the motor, and the drive will lose all torque and coast to a stop.

The STO safety concept is certified by the IFA (Institut für Arbeitsschutz der Deutschen Gesetzlichen Unfallversicherung). The safety circuit concept for realizing the safety function "Safe Torque Off" in the drive is suited for SIL 2 according to EN 61800-5-2 and PL d / CAT 3 according to ISO 13849-1.

The subsystems (AKD drives) are totally described for safety technics with the characteristic data :

Device	Operation Mode	EN 13849-1	EN 62061	PFH [1/h]	SFF[%]
STO	STO single channel	PL d, CAT 3	SIL 2	0	20

4 Handling

4.1 Transport	25
4.2 Packaging	25
4.3 Storage	25
4.4 Maintenance and Cleaning	26
4.5 Uninstalling	26
4.6 Repair and Disposal	26

4.1 Transport

Transport the AKD in accordance with IEC 61800-2 as follows:

- Transport only by qualified personnel in the manufacturer's original recyclable packaging.
- Avoid shocks while transporting.
- Transport only within specified temperature ranges: -25 to +70 °C, max. rate of change 20 K/hour, class 2K3.
- Transport only within specified humidity: max. 95% relative humidity, no condensation, class 2K3.

NOTICE

The drives contain electrostatically sensitive components that can be damaged by incorrect handling. Electrostatically discharge yourself before touching the drive. Avoid contact with highly insulating materials, such as artificial fabrics and plastic films. Place the drive on a conductive surface.

If the packaging is damaged, check the unit for visible damage. Inform the shipper and the manufacturer of any damage to the package or product.

4.2 Packaging

The AKD packaging consists of recyclable cardboard with inserts and a label on the outside of the box.

Model	Package Dimensions (mm) HxWxL	Total Weight (kg)
AKD-x00306 and AKD-x00606	77 x 280 x 222	1.7
AKD-x01206	153 x 394 x 229	3.4
AKD-x02406	153 x 394 x 229	5
AKD-x00307 and AKD-x00607	153 x 394 x 229	4.3
AKD-x01207	153 x 394 x 229	4.3
AKD-x02407	153 x 394 x 229	6.7

4.3 Storage

Store the AKD in accordance with IEC 61800-2 as follows:

- Store only in the manufacturer's original recyclable packaging.
- Store at or below maximum stacking height:
 - AKD-x0306 to 0606 models: 8 cartons
 - All other models: 6 cartons
- Store only within specified temperature ranges: -25 to +55 °C, max. rate of change 20 K/hour, class 1K4.
- Storage only within specified humidity: 5 to 95% relative humidity, no condensation, class 1K3.
- Store in accordance with the following duration requirements:
 - Less than 1 year: without restriction.
 - More than 1 year: capacitors must be re-formed before setting up and operating the drive. To re-form the capacitors, remove all electrical connections and apply single-phase 120 Vac for about 30 minutes to the L1/L2 terminals.

4.4 Maintenance and Cleaning

The drive does not require maintenance. Opening the drive voids the warranty.

The inside of the unit can only be cleaned by the manufacturer. To clean the drive exterior:

- Casing: Clean with isopropanol or similar cleaning solution.
- Protective grill on fan: Clean with a dry brush.

NOTICE Do not immerse or spray the drive.

4.5 Uninstalling

If a drive must be uninstalled (such as for replacement), remove the drive as follows:

1. Switch off the main switch of the switchgear cabinet and the fuses that supply the system.

▲ WARNING Wait at least seven minutes after disconnecting the drive from the main supply power before touching potentially live sections of the equipment (e.g. contacts) or undoing any connections. Always measure the voltage in the DC bus link and wait until the voltage is below 40 V before touching or handling the drive.

2. Remove the connectors. Disconnect the potential earth connection last.
3. Check temperature.

▲ CAUTION During operation, the heat sink of the drive may reach temperatures above 80 °C (176 °F). Before touching the device, check the temperature and wait until it has cooled below 40 °C (104 °F).

4. Uninstall. Remove the drive and power supply from the conductive, grounded mounting plate in the cabinet.

4.6 Repair and Disposal

Only the manufacturer can repair the drive. Opening the device voids the warranty. Uninstall the drive as described in "Uninstalling" (=> p. 26) and send it in the original packaging to the manufacturer (see table below).

In accordance with the WEEE-2002/96/EC-Guidelines and similar, the manufacturer accepts returns of old devices and accessories for professional disposal. Transport costs are the responsibility of the sender. Send the devices to the manufacturer addresses shown in the table below.

USA	Europe
Kollmorgen™ 201 West Rock Road Radford, VA 24141	KOLLMORGEN Europe GmbH Pempelfurtstr. 1 D-40880 Ratingen

5 Package

5.1 Package Supplied.....	28
5.2 Nameplate.....	28
5.3 Part number scheme.....	29

5.1 Package Supplied

When a drive from the AKD series is ordered (=> p. 141), the following items are included in the drive package:

- AKD
- Printed copy of *AKD Installation Manual* (EU only)
- Printed copy of *AKD Quick Start*
- Printed copy of fault and warning card
- CD-ROM containing the setup software, WorkBench, and all product documentation in digital format.
- Mating connectors X1, X2, X3, X4 (if required), X7, and X8
- Grounding plate, L-shape or Flat depending on AKD voltage type

NOTE The mating SubD and RJ45 connectors are not included in the package.

Accessories Sold Separately

Accessories must be ordered separately if required; refer to your regional accessories manual:

- EMC filters for 24 V and mains supply voltage, categories C2 or C3
- External brake resistor
- Motor cable. Assembled motor cables are available for all regions. EU customers may also order motor cable at custom lengths and assemble the cable with power connectors ordered separately.
- Feedback cable. Assembled feedback cables are available for all regions. EU customers may also order feedback cable at custom lengths and assemble the cable with connectors ordered separately.
- Motor choke, for motor cables longer than 25 m
- CAN termination connector (with CAN drives only)
- Service cable to the network
- Power cable, control cables, and fieldbus cables (as cutoff lengths)

5.2 Nameplate

The nameplate depicted below is attached to the side of the drive, sample data entries are for a 12 A type.

KOLLMORGEN		Customer Support:	
201 W. Rock Road Radford, VA 24141		North America: +1 (540) 633-3400 Europe: +49 (0) 203-69790 Italy: +39 (0) 362-694260	
Model No: AKD-B01207-NACN-0000			
Serial No: R-0912-00001		HW Rev: A	
MAC Address: 00-00-00-00-00-00			
	<i>INPUT</i>	<i>OUTPUT</i>	
Voltage	480 Vac	0-480 Vac	 LISTED IND. CONT. EQ. 98F2
Frequency	50/60 Hz	0-600 Hz	
Phase	3 Ph	3 Ph	
FL Current	9.2 Arms	12 Arms	
Power @ 480 Vac	7.65 kVA		
Enclosure Protection Rating:		IP20	
<div style="display: flex; justify-content: space-between; align-items: center;"> Before use, refer to CD for installation and safety information. </div>			
Assembled in USA		Patents Pending www.kollmorgen.com	

5.3 Part number scheme

The part number is identical to the order code.

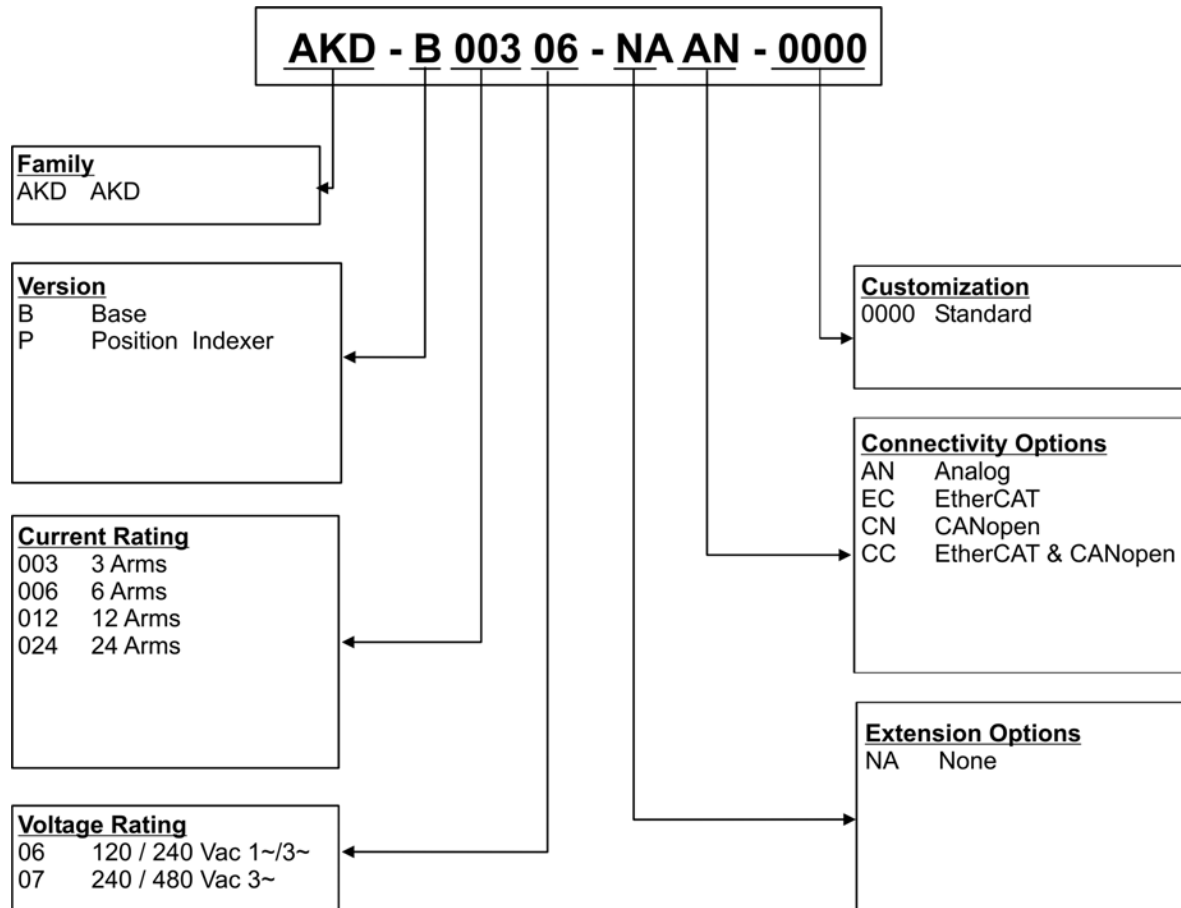

Version: "B" (base version) is not available in Europe

Voltage Rating: Presently the AKD-xzzz07 models only support operation at levels above 270 Vac. Updates to the AKD firmware are in process to allow the operation of the AKD-xzzz07 models drives at 240Vac. These updates will only require a firmware modification and will be backwards compatible with all AKD-xzzz07 hardware."

Customization: this code includes language version of printed material for European countries:

- D000 for German
- E000 for English
- F000 for French
- I000 for Italian

Connectivity Options: The drive models with connectivity option CC are fitted with both the EtherCAT (X5 and X6) and CANopen (X12 and X13) fieldbus connectors. A software parameter (DRV.TYPE) allows you to select what features the drive supports; you cannot use EtherCAT and CANopen at the same time.

6 Technical description and data

6.1	The AKD Family of Digital Drives.....	31
6.2	Ambient Conditions, Ventilation, and Mounting Position.....	33
6.3	Mechanical Data.....	33
6.4	Inputs/Outputs.....	33
6.5	Electrical Data AKD-xzzz06.....	34
6.6	Electrical Data AKD-xzzz07.....	35
6.7	Performance Data.....	36
6.8	Recommended tightening torques.....	36
6.9	Fusing.....	37
6.10	Connectors.....	38
6.11	Cable and Wire Requirements.....	39
6.12	LED display.....	40
6.13	Grounding System.....	40
6.14	Dynamic Braking.....	41
6.15	Switch-on and Switch-off Behavior.....	44
6.16	Stop-/Emergency Stop- Standards.....	51
6.17	Safe Torque Off (STO).....	53
6.18	Shock-hazard Protection.....	59

6.1 The AKD Family of Digital Drives

Standard features

- Supply voltage range 120 V to 480 V $\pm 10\%$
- Several housing dimensions, depending on current and hardware options.
- Motion bus onboard.
- TCP/IP service channel onboard.
- SFD, Resolver, Comcoder, 1Vp-p Sin-Cos encoders, incremental encoders support onboard.
- Support for ENDAT 2.1 & 2.2, BISS or HIPERFACE protocols onboard.
- Encoder emulation onboard.
- Second feedback support.
- Safe Torque Off (STO) according to IEC 61508 SIL 2 onboard.
- Use with Synchronous servomotors, linear motors, and induction machines can be used.

Available AKD versions

- B - Base drive is controlled by analog torque and velocity commands (electronic gearing).
- P - Position Indexer drive adds the ability to command multiple motions, process I/O, make decisions, add time delays, and modify drive process variables to the base drive.
- T - (in process) Structured Text drive adds simple programmability (similar to Basic) to the base drive.
- S - (in process) Single Axis KAS is a one-axis programmable drive features KAS software built in to the drive. Includes all five IEC 61131 languages, PLC Open and Pipes Network.
- M - (in process) Multi Axis KAS master drive runs two to four axes. Includes all five IEC 61131 languages, PLC Open and Pipes Network.

Power section

- One or three phase supply, voltage range 120 to 480 V $\pm 10\%$, 50 to 400 Hz $\pm 5\%$ or DC.
- Connection to higher voltage mains only via isolating transformer, => p. 85
- B6 bridge rectifier, integral soft-start circuit.
- Single phase supply possible with output power derating.
- Fusing to be provided by the user.
- Shielding star point close to the drive.
- DC bus link voltage range 170 to 680 Vdc, can be connected in parallel.
- Output stage IGBT module with floating current measurement.
- Brake circuit with dynamic distribution of the generated power between several drives on the same DC bus link circuit.
- Internal brake resistor for all 240/480 Vac AKD-xzzz07 models (only 120/240 Vac 3 A and 6 A AKD-xzzz06 models lack internal brake resistors.), external brake resistors if required.

Integrated safety

- Appropriate insulation/creepage distances and electrical isolation for safe electrical separation, per IEC 61800-5-1, between the power input/motor connections and the signal electronics.
- Soft-start, overvoltage detection, short-circuit protection, phase-failure monitoring.
- Temperature monitoring of the drive and motor.
- Motor overload protection: foldback mechanism
- SIL 2 safe torque off in accordance with IEC 61508, => p. 53.
- Optional safety functions for the safe operation of drive shafts in accordance with IEC 61800-5-2 (in process).

Auxiliary supply voltage 24V DC

- From an external, safety approved 24 V \pm 10% power supply.

Operation and parameter setting

- Using the setup software WorkBench, for setup via TCP/IP.

Full digital control

- Digital current controller (670 ns)
- Adjustable digital velocity controller (62.5 μ s)
- Software option position controller (125 μ s)

Inputs/Outputs

- 1 programmable analog input => p. 111
- 1 programmable analog output => p. 112
- 7 programmable digital inputs => p. 113
- 2 programmable digital outputs => p. 116
- 1 Enable input => p. 113
- 1 STO input => p. 53

Option Cards (in process)

Several option cards are in process. These options will affect the device width.

Connectivity

- Analog +/- 10 V control with encoder feedback output.

Onboard Serial Interface (=> p. 120), optional

- CANopen => p. 120

Onboard Ethernet interface (=> p. 123), optional

- SynqNet => p. 123
- EtherCAT => p. 123

6.2 Ambient Conditions, Ventilation, and Mounting Position

Storage	=> p. 24
Transport	=> p. 24
Ambient temperature in operation	0 to +40 °C under rated conditions +40 to +55 °C with continuous current derating 4 % per Kelvin
Humidity in operation	Relative humidity 5 to 85%, no condensation, class 3K3
Site altitude	Up to 1000 meters AMSL without restriction 1,000 to 2,500 meters AMSL with power derating 1.5%/100 m
Pollution level	Pollution level 2 as per IEC 60664-1
Vibrations	Class 3M1 according to IEC 60721-3-3
Enclosure protection	IP 20 according to IEC 60529
Mounting position	Vertical, => p. 62
Ventilation	Built-in fan
NOTICE	The drive shuts down (fault F234, => p. 133, motor has no torque) in case of excessively high temperature in the control cabinet. Make sure sufficient forced ventilation is supplied within the control cabinet.

AMSL = above mean sea level

6.3 Mechanical Data

Mechanical data	Units	AKD-x00306	AKD-x00606	AKD-x01206	AKD-x02406
Weight, standard	kg	1.1		2	3.7
Weight, delivery package	kg	1.7		3.4	5
Height, without connectors	mm	168		196.3	237.7
Height, with service connector	mm	200		225	280
Width front/back, standard	mm	53/59		75.3/78.3	97/100
Depth, without connectors	mm	156		187	228
Depth, with connectors	mm	185		< 215	<265

Mechanical data	Units	AKD-x00307	AKD-x00607	AKD-x01207	AKD-x02407
Weight, standard	kg		2.7		5.3
Weight, delivery package	kg		4.3		6.7
Height, without connectors	mm		256		306
Height, with service connector	mm		290		340
Width front/back, standard	mm		67/70		101.3/105
Depth, without connectors	mm		185		228
Depth, with connectors	mm		<225		<265

6.4 Inputs/Outputs

Interface	Electrical Data
Analog input (resolution 16 bit)	±10 Vdc
Max. common-mode voltage	±10 Vdc
Analog output (resolution 16 bit)	±10 Vdc
Digital inputs	min. 3.5 Vdc, max. 30 Vdc min. 2 mA, max. 15 mA
Digital outputs	max. 30 Vdc, 100 mA
FAULT output, relay contacts	max. 30 Vdc, max 42 Vac, 1 A

6.5 Electrical Data AKD-xzzz06

Electrical Data	Units	AKD-x00306	AKD-x00606	AKD-x01206	AKD-x02406
Rated supply voltage	V	3 x 120 V to 240 V $\pm 10\%$ 1 x 120 V to 240 V $\pm 10\%$			3x240 V $\pm 10\%$
Rated supply input frequency	Hz	50 Hz to 400 Hz $\pm 5\%$ or DC			
Rated input power for S1 operation	kVA	1.2	2.38	3.82	7.6
Rated input current					
at 1x120 V	A	5.0	9.9	12	N/A
at 1x240 V	A	5.0	9.9	12	N/A
at 3x120 V	A	2.3	4.6	9.2	N/A
at 3x240 V	A	2.3	4.6	9.2	18.3
Permitted switch on/off frequency	1/h	30			
Max. inrush current	A	10	10	10	20
Rated DC bus link voltage (Bus Turn on Delay 3ph 1 sec)	V	170 to 340			
Continuous output current ($\pm 3\%$)					
at 120 V	Arms	3	6	12	N/A
at 240 V	Arms	3	6	12	24
Peak output current (for approx. 5 s, $\pm 3\%$)	Arms	9	18	30	48
Continuous output power					
at 1x120 V	W	312.5	625	1250	N/A
at 1x240 V	W	625	1250	2500	N/A
at 3x120 V	W	312.5	625	1250	N/A
at 3x240 V	W	625	1250	2500	5000
Peak output power (for approx. 5 s)					
at 1x120 V	kVA	0.937	1.875	3.125	N/A
at 1x240 V	kVA	1.875	3.750	6.250	N/A
at 3x120 V	kVA	0.937	1.875	3.125	N/A
at 3x240 V	kVA	1.875	3.750	6.250	10
Technical data for brake circuit	—	=> p. 41			
Motor inductance min.					
at 120 V	mH	1.3	0.6	0.5	0.3
at 240 V	mH	2.5	1.3	1	0.6
Motor inductance max.					
Thermal dissipation, output stage disable	W	max. 20	max. 20	max. 20	max. 25
Thermal dissipation at rated current	W	31	57	137	175
Noise emission (low speed/high speed fan)	dB(A)	N/A	33/39	37/43	41/56
Aux. voltage supply	V	24 V ($\pm 10\%$, check voltage drop)			
-current w/o motor brake, w/o option card	A	0.5	0.6	0.7	1.0
-current w/o motor brake with option card	A	1.2	1.3	1.4	1.7
-current with motor brake, w/o option card	A	1.7	1.8	1.9	2.5
-current with motor brake and option card	A	2.4	2.5	2.6	3.2

6.6 Electrical Data AKD-xzzz07

Electrical data	Units	AKD-x00307	AKD-x00607	AKD-x01207	AKD-x02407
Rated supply voltage	V	3 x 240 V to 480 V $\pm 10\%$			
Rated supply input frequency	Hz	AC with 50 Hz to 400 Hz $\pm 5\%$ or DC			
Rated input power for S1 operation	kVA	2.24	4.49	7.65	15.2
Rated input current					
at 3x240 V	A	2.7	5.4	9.2	18.3
at 3x400 V	A	2.7	5.4	9.2	18.3
at 3x480 V	A	2.7	5.4	9.2	18.3
Permitted switch on/off frequency	1/h	30			
Max. inrush current	A	10	10	10	20
Rated DC bus link voltage (Bus Turn on Delay 3ph 1 sec)	V=	340 to 680			
Continuous output current ($\pm 3\%$)					
at 240 V	Arms	3	6	12	24
at 400 V	Arms	3	6	12	24
at 480 V	Arms	3	6	12	24
Peak output current (for approx.5 s, $\pm 3\%$)	Arms	9	18	30	48
Continuous output power					
at 3x240 V	kVA	0.6	1.25	2.5	5
at 3x400 V	kVA	1	2	4.2	8.3
at 3x480 V	kVA	1.2	2.5	5	10
Peak output power (for approx.5 s)					
at 3x240 V	kVA	1.8	3.75	6.25	10
at 3x400 V	kVA	3	6.75	10.4	16.7
at 3x480 V	kVA	3.6	7.5	12.5	20
Technical data for brake circuit	—	=> p. 41			
Motor inductance min.					
at 240 V	mH	3.2	1.6	1.3	0.6
at 400 V	mH	5.3	2.6	2.1	1
at 480 V	mH	6.3	3.2	2.5	1.2
Motor inductance max.					
Thermal dissipation, output stage disable	W	max. 20	max. 20	max. 20	max. 25
Thermal dissipation at rated current	W	102	129	153	237
Noise emission (low speed/high speed fan)	dB(A)	34/43	34/43	44/52	48/58
Aux. voltage supply	V=	24 V ($\pm 10\%$, check voltage drop)			
- current w/o motor brake, w/o option card	A=	1	1	1	2
- current w/o motor brake with option card	A=	1.7	1.7	1.7	2.7
- current with motor brake, w/o option card	A=	2.5	2.5	2.5	4
- current with motor brake and option card	A=	3.2	3.2	3.2	4.7

Presently the AKD-xzzz07 models only support operation at levels above 270 Vac. Updates to the AKD firm-ware are in process to allow the operation of the AKD-xzzz07 models drives at 240Vac.

6.7 Performance Data

AKD-xzzz06

Performance Data	Units	AKDx 00306	AKDx 00606	AKDx 01206	AKDx 02406
Switching frequency of output stage	kHz	10	10	8	8
Voltage rise speed dU/dt	kV/ μ s	2.5			4.3
Bandwidth of current controller	kHz	2.5 to 4		2 to 3	
Bandwidth of velocity controller (scalable)	Hz	0 to 1000		0 to 800	0 to 600
Bandwidth of position controller (scalable)	Hz	1 to 250			

AKD-xzzz07

Performance Data	Units	AKDx 00307	AKDx 00607	AKDx 01207	AKDx 02407
Switching frequency of output stage	kHz	8	8	6	8
Voltage rise speed dU/dt	kV/ μ s	7.2			
Bandwidth of current controller	kHz	2.5 to 4		2 to 3	
Bandwidth of velocity controller (scalable)	Hz	0 to 800	0 to 600		
Bandwidth of position controller (scalable)	Hz	1 to 250			

6.8 Recommended tightening torques

Connector	Tightening Torque/Nm		
	AKD-x00306 to 00606	AKD-x01206	AKD-x02406 and AKD-xzzz07
X1	0.22 to 0.25	0.22 to 0.25	0.7 to 0.8
X2	0.5 to 0.6	0.7 to 0.8	0.7 to 0.8
X3	0.5 to 0.6	0.5 to 0.6	0.7 to 0.8
X4	-	-	0.7 to 0.8
X7, X8	0.2 to 0.25	0.2 to 0.25	0.2 to 0.25
PE block	1.7	1.7	1.7

See "Conformance with UL/cUL" (=> p. 18) for in-lbs values.

6.9 Fusing

US fuses:

Class J, 600 Vac 200 kA, time-delay. The fuse must be UL and CSA listed, UL recognized is not sufficient.

EU fuses:

types gRL or gL, 400 V/500 V, time-delay

Fuse holders

Combined with the standard fuse blocks, finger safe fuse holders must be used according to IEC 60529.

Examples:

Bussmann: CH Series Modular Fuse Holders, fuse size 0 to 30A class J, 3 poles: CH30J3

Ferraz: Ultrasafe Fuse holders, fuse size 0 to 30A class J, 3 poles: US3J3I

6.9.1 External Power Supply fusing

Drive Model	Max. Ampere rating	Example class J Cooper Bussmann	Example class J Ferraz Shawmut
AKD-X00306	10A (Time-Delay)	LPJ10/DFJ10	AJT10/HSJ10
AKD-X00606	15A (Time-Delay)	LPJ15/DFJ15	AJT15/HSJ15
AKD-X01206	15A (Time-Delay)	LPJ15/DFJ15	AJT15/HSJ15
AKD-X02406	30A (Time-Delay)	LPJ30/DFJ30	AJT30/HSJ30
AKD-X00307	6A (Time-Delay)	LPJ6/DFJ6	AJT6/HSJ6
AKD-X00607	10A (Time-Delay)	LPJ10/DFJ10	AJT10/HSJ10
AKD-X01207	15A (Time-Delay)	LPJ15/DFJ15	AJT15/HSJ15
AKD-X02407	30A (Time-Delay)	LPJ30/DFJ30	AJT30/HSJ30

6.9.2 External 24 V supply fusing

Drive Model	Max. Ampere rating	Example class J Cooper Bussmann	Example class J Ferraz Shawmut
all AKD	8A (Time-Delay)	LPJ8/DFJ8	AJT8/HSJ8

6.9.3 External Brake Resistor fusing

Drive Model	Max. Ampere rating	Example class KLM-xx Cooper Bussmann
all AKD	6A (Time-Delay)	in process

6.10 Connectors

Given voltage and current data are the lowest values allowed by UL and CE. Order codes => p. 141

6.10.1 AKD-xzzz06 Types (120V to 240V Mains Voltage Supply)

Connector	Type	Max. Cross Section ¹	Allowed Current ²	Allowed Voltage ³
Control signals X7 / X8	Amphenol, ELXP1010S1 / 1010S2	1.5 mm ² , 16 awg	10 A	250 V
Aux. voltage X1	Phoenix, MC1.5/3-STF-3.81	1.5 mm ² , 16 awg	8 A	160 V
Motor X2 (3 to 6 A)	Phoenix, IC 2.5/6-STF-5.08	2.5 mm ² , 14 awg	10 A	300 V
Motor X2 (12 to 24A)	Phoenix, PC 5/6-STF-7.62	10 mm ² , 10 awg	30 A	600 V
Power X3 (3 to 6A)	Phoenix, MVSTBW2.5/7-STF-5.08	2.5 mm ² , 12 awg	10 A	300 V
Power X3 (12A)	Phoenix, MSTB2,5HC/8-STF-5,08	2,5 mm ² , 12 awg	16 A	300 V
Power X3 (24A)	Phoenix, PC 5/4-STF-7,62	10 mm ² , 10 awg	30 A	600 V
Power X4 (24A)	Phoenix, PC 5/4-STF-7,62	10 mm ² , 10 awg	30 A	600 V
Feedback X10	SubD 15pin HD (female)	0,5 mm ² , 21 awg	1 A	<100 V
Service Port X11	RJ45	0,5 mm ² , 21 awg	1 A	<100 V
Motion Bus X5, X6	RJ45	0,5 mm ² , 21 awg	1 A	<100 V
CAN In/Out X12/13	RJ25	0,5 mm ² , 21 awg	1 A	<100 V
Encoder Emulation X9	SubD 9pin (male)	0,5 mm ² , 21 awg	1 A	<100 V

¹single-line connection

²single-line connection with recommended conductor cross section (=> p. 39)

³rated voltage with pollution level 2

6.10.2 AKD-xzzz07 Types (240V to 480V Mains Voltage Supply)

Connector	Type	Max. Cross Section ¹	Allowed Current ²	Allowed Voltage ³
Control signals X7 /X8	Amphenol, ELXP1010S1 / 1010S2	1.5 mm ² , 16 awg	10 A	250 V
Aux. voltage X1	Phoenix, MC1.5/3-STF-3.81	1.5 mm ² , 16 awg	8 A	160 V
Motor X2	Phoenix, PC 5/6-STF-7.62	10 mm ² , 10 awg	30 A	600 V
Power X3	Phoenix, PC 5/4-STF-7,62	10 mm ² , 10 awg	30 A	600 V
Power X4	Phoenix, PC 5/4-STF-7,62	10 mm ² , 10 awg	30 A	600 V
Feedback X10	SubD 15pin HD (female)	0,5 mm ² , 21 awg	1 A	<100 V
Service Port X11	RJ45	0,5 mm ² , 21 awg	1 A	<100 V
Motion Bus X5, X6	RJ45	0,5 mm ² , 21 awg	1 A	<100 V
CAN In/Out X12/13	RJ25	0,5 mm ² , 21 awg	1 A	<100 V
Encoder Emulation X9	SubD 9pin (male)	0,5 mm ² , 21 awg	1 A	<100 V

¹single-line connection

²single-line connection with recommended conductor cross section (=> p. 39)

³rated voltage with pollution level 2

6.11 Cable and Wire Requirements

6.11.1 General

For information on the chemical, mechanical, and electrical characteristics of the cables please refer to the accessories manual or contact customer support.

NOTE

To reach the maximum permitted cable length, you must use cable material with the following capacitance (phase to shield) requirements:

- Motor cable: less than 150 pF/m
- Resolver/Encoder cable: less than 120 pF/m

Motor cables longer than 25 m may require the use of a motor choke.

6.11.2 Cable Cross Sections and Requirements

The table below describes the recommended interface cross sections and cable requirements for single-axis systems in accordance with IEC 60204. For multi-axis systems, observe the specific operating conditions for your system.

Interface	Cross Section	Cable Requirements
AC connection	AKD-x003 to 6: 1.5 mm ² (16 awg) AKD-x012: 2.5 mm ² (14 awg) AKD-x024: 4 mm ² (12 awg)	600 V, minimum 75°C
DC bus link, Brake resistor	AKD-x003 to 6: 1.5 mm ² (16 awg) AKD-x012 to 24: 2.5 mm ² (14 awg)	1000 V, minimum 75°C, shielded for lengths >0.20 m
Motor cables without choke, max. 25 m	AKD-x003 to 6: 1.5 mm ² (16 awg) AKD-x012: 2.5 mm ² (14 awg) AKD-x024: 4 mm ² (12 awg)	600 V, minimum 75°C, shielded, capacitance <150 pF/m
Motor cables with choke, 25 - 50 m	AKD-x003 to 6: 1.5 mm ² (16 awg) AKD-x012: 2.5 mm ² (14 awg) AKD-x024: 4 mm ² (12 awg)	600 V, minimum 75°C, shielded, capacitance <150 pF/m
Resolver, max. 100 m	4x2x0.25 mm ² (24 awg)	twisted pairs, shielded, capacitance <120 pF/m
SFD, max. 50 m	1x2x0.25 mm ² (24 awg) 1x2x0.50 mm ² (21 awg)	twisted pairs, shielded
Encoder, max. 50 m	7x2x0.25 mm ² (24 awg)	twisted pairs, shielded
ComCoder, max. 25 m	8x2x0.25 mm ² (24 awg)	twisted pairs, shielded
Analog I/Os, max. 30 m	0.25 mm ² (24 awg)	twisted pairs, shielded
Digital I/Os, max. 30 m	0.5 mm ² (21 awg)	single line
Holding brake (motor)	min. 0.75 mm ² (19 awg)	600 V, minimum 75°C, shielded
+24 V/GND, max 30 m	max. 2.5 mm ² (14 awg)	single line

6.12 LED display

A two-character, LED seven-segment display indicates the status of the drive after the 24 V supply is switched on. Fault codes or warning codes are displayed constantly if present. The IP address can be flashed across the LED display if the B1 button is pressed, or if the RJ45 cable is re-inserted into the X11 connection.



6.13 Grounding System

There are four ground networks in the drive:

AGND	analog ground
DCOM7	common line for digital inputs on I/O connector X7
DCOM8	common line for digital inputs on I/O connector X8
GND	24 V supply, STO input, holding brake
0 V	internal digital ground, encoder emulation output, service channel

6.14 Dynamic Braking

Dynamic braking is a method to slow down a servo system by dissipating the mechanical energy driven by the motor back EMF. The AKD has a built in advanced (patent pending) dynamic braking mode which operates fully in hardware. When activated, the drive shorts the motor terminals in phase with the back EMF (q axis) but continues to operate the non-force producing current loop (d-axis) with 0 current. This forces all of the dynamic braking current to be stopping current and insures the fastest stopping/amp of motor terminal current.

- When current is not being limited, the mechanical energy is being dissipated in the motor resistance.
- When current is being limited, energy is returned to the drive bus capacitors.
- The drive also limits the maximum dynamic braking motor terminal current via the *DRV.DBILIMIT* parameter to insure that the drive, motor, and customer load do not see excessive currents/forces.

Whether and how the AKD uses dynamic braking depends on the disable mode (*DRV.DISMODE*).

6.14.1 Brake Chopper

When the amount of returned energy builds the bus capacitor voltage up enough the drive activates the brake chopper to start dumping the returned energy in the brake resistor (also called regen or regenerative resistor). This resistor could be internal or connected external to the drive, depending on drive model and drive wiring.

AKD-x00306 to AKD-x00606

No internal brake resistor. Depending on the application requirements, an external resistor can be connected.

AKD-x01206 to AKD-x02406 and AKD-xzzz07

With internal resistor plus the capability to connect an external resistor depending on the application requirements.

NOTE	External brake resistors are described in the <i>AKD Accessories Manual</i>.
-------------	---

6.14.1.1 Functional description

When the amount of returned energy builds the bus capacitor voltage up enough the drive activates the brake chopper to start dumping the returned energy in the brake resistor.

1. Individual drives, not coupled through the DC bus link circuit (+DC, -DC)

When the energy fed back from the motor has an average or peak power that exceeds the preset level for the brake power rating, the drive generates the warning "n521 Regen Over power". After the warning is issued, if the power increases past the fault level, the brake chopper will switch off.

With the brake chopper switched off, the drive internal DC bus link voltage is supervised. The drive reports an over-voltage fault if the DC bus threshold is exceeded. The drive power stage is disabled and the load coasts to a stop with the fault message "F501 Bus Over voltage" (=> p. 133). The Fault contact (terminals X8/9-10) is opened (=> p. 117) due to this fault.

2. Several drives coupled through the DC bus link (+DC, -DC)

Using the built-in brake chopper, several drives of the same series can be operated from a common DC-bus link (=> p. 90), without any additional measures. 90% of the combined power of all the coupled drives is always available for peak and continuous power. The switch-off on over voltage takes place as described under 1. (above) for the drive that has the lowest switch-off threshold (resulting from tolerances).

NOTE	Observe the regeneration time (some minutes) for the dynamic brake circuit after full load with peak brake power.
-------------	--

6.14.1.2 Technical Data for AKD-xzzz06

Technical data for the brake chopper depends on the drive type and the mains voltage.
Supply voltages, capacitances, and switch-on voltages are all nominal values.

Brake circuit			Supply voltage
Type	Rated data	Units	120 V / 240 V
AKD-xzzz06 all types	Switch-on threshold of brake chopper	V	400
	Switch-off threshold of brake chopper	V	420
	Maximum brake duty cycle	%	15*

Type	Rated data	Units	120 V / 240 V
AKD-x00306	External brake resistor	Ohm	33
	Maximum continuous brake power, external resistor	kW	0.77
	Peak brake power, external (1s)	kW	5.4
	Absorption energy in capacitors (+/- 20%)	Ws	60 / 20
	DC Bus Capacitance	µF	940
AKD-x00606	External brake resistor	Ohm	33
	Maximum continuous brake power, external resistor	kW	1.5
	Peak brake power, external resistor (1s)	kW	5.4
	Absorption energy in capacitors (+/- 20%)	Ws	60 / 20
	DC Bus Capacitance	µF	940
AKD-x01206	Internal brake resistor	Ohm	15
	Continuous power, internal resistor	W	100
	Peak brake power, internal resistor (0.5s)	kW	11.7
	External brake resistor	Ohm	33
	Maximum continuous brake power, external resistor	kW	3
	Absorption brake power, external resistor (1s)	kW	5.4
	Storeable energy in capacitors (+/- 20%)	Ws	160 / 55
	DC Bus Capacitance	µF	2460
AKD-x02406	Internal brake resistor	Ohm	8
	Continuous power, internal resistor	W	200
	Peak brake power, internal resistor (0.5s)	kW	22
	External brake resistor	Ohm	15
	Maximum continuous brake power, external resistor	kW	6
	Peak brake power, external resistor (1s)	kW	11.8
	Absorption energy in capacitors (+/- 20%)	Ws	180 / 60
	DC Bus Capacitance	µF	2720

* depends on connected brake resistor power

6.14.1.3 Technical Data for AKD-xzzz07

Brake circuit			Supply voltage	
Type	Rated data	Units	240 V	400 V / 480 V
AKD-xzzz07 all types	Switch-on threshold of brake chopper	V	400	800
	Switch-off threshold of brake chopper	V	420	840
	Maximum brake duty cycle	%	15*	
Type	Rated data	Units	240 V	400 V / 480 V
AKD-x00307	Internal brake resistor	Ohm	33	
	Continuous power, internal resistor	W	80	
	Peak brake power, internal resistor (0.5s)	kW	5.5	22.1
	External brake resistor	Ohm	33	
	Maximum continuous brake power, external resistor	kW	0.77	1.5
	Peak brake power, external (1s)	kW	5,4	21.4
	Absorption energy in capacitors (+/- 20%)	Ws	5	35 / 20
	DC Bus Capacitance	µF	235	
AKD-x00607	Internal brake resistor	Ohm	33	
	Continuous power, internal resistor	W	100	
	Peak brake power, internal resistor (0.5s)	kW	5.4	21.4
	External brake resistor	Ohm	33	
	Maximum continuous brake power, external resistor	kW	1.5	3
	Peak brake power, external resistor (1s)	kW	5.4	21.4
	Absorption energy in capacitors (+/- 20%)	Ws	5	35 / 20
	DC Bus Capacitance	µF	235	
AKD-x01207	Internal brake resistor	Ohm	33	
	Continuous power, internal resistor	W	100	
	Peak brake power, internal resistor (0.5s)	kW	5.4	21.4
	External brake resistor	Ohm	33	
	Maximum continuous brake power, external resistor	kW	3	6
	Peak brake power, external resistor (1s)	kW	5.4	21.4
	Absorption energy in capacitors (+/- 20%)	Ws	10	70 / 40
	DC Bus Capacitance	µF	470	
AKD-x02407	Internal brake resistor	Ohm	23	
	Continuous power, internal resistor	W	200	
	Peak brake power, internal resistor (0.5s)	kW	7.7	30.6
	External brake resistor	Ohm	23	
	Maximum continuous brake power, external resistor	kW	6	12
	Peak brake power, external resistor (1s)	kW	7.7	30.6
	Absorption energy in capacitors (+/- 20%)	Ws	15	110 / 60
	DC Bus Capacitance	µF	680	

* depends on connected brake resistor power

Presently the AKD-xzzz07 models only support operation at levels above 270 Vac. Updates to the AKD firmware are in process to allow the operation of the AKD-xzzz07 models drives at 240Vac."

6.15 Switch-on and Switch-off Behavior

This chapter describes the switch-on and switch-off behavior of the AKD.

Behavior of “holding brake” function

Drives with an enabled holding brake function have a special timing for switching on and off the output stage (=> p. 93). Events that remove the DRV.ACTIVE signal trigger the holding brake to apply.. As with all electronic circuits, the general rule applies that there is a possibility of the internal holding brake module failing. Personnel safety, e.g. with hanging load (vertical axes), requires an additional mechanical brake which must be safely operated, for example by a safety control.

If velocity drops below threshold $CS.VTHRESH$ or timeout occurs during a stop procedure, the brake is closed.

Behavior when undervoltage condition is present

The behavior in an undervoltage condition depends on the VBUS.UVMODE setting.

VBUS.UVMODE	DC Bus Undervoltage Mode. Consult the <i>AKD User Guide</i> for configuring the parameter.
0	The drive will report a F502 undervoltage fault any time an undervoltage condition occurs.
1 (default)	The drive will report a warning n502 if not enabled. The drive will report a fault if the drive is enabled when the condition occurs, or an attempt is made to enable while an under voltage condition occurs.

Safety function STO

With the personnel safe function STO, the drive can be secured on standstill using its internal electronics so that even when power is being supplied, the drive shaft is protected against unintentional restart. The chapter “Safe Torque Off (STO)” describes how to use the STO function (=> p. 53).

6.15.1 Switch-on behavior in standard operation

The diagram below illustrates the correct functional sequence for switching the drive on.

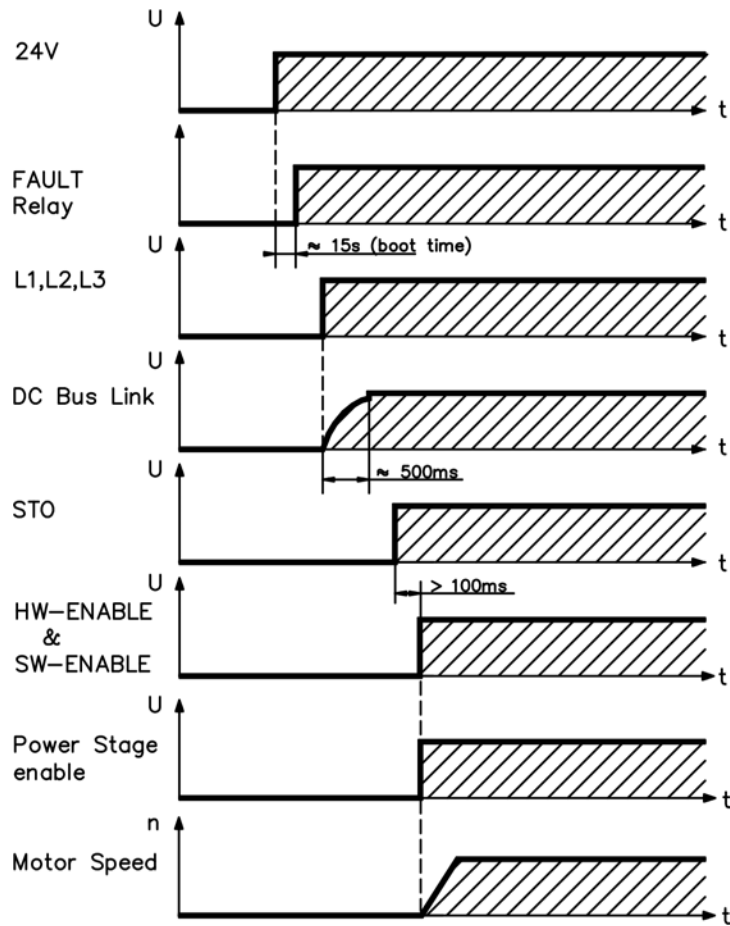

Fault F602 occurs when STO does not have current when HW enable becomes active (\Rightarrow p. 53 for more information about STO function).

6.15.2 Switch-off behavior

NOTE The drive's 24 V supply must remain constant. Hardware Enable input disable the power stage immediately. Configured Digital Inputs and fieldbus commands can be used to perform controlled stops.

6.15.2.1 Switch-off behavior using the DRV.DIS command

The enable/disable button in WorkBench issues a *drv.dis* command internally to the drive. See *AKD User Guide* for configuring inputs and software commands. Sometimes this enable signal is called "Software Enable" (SW-Enable).

DRV.DISMODE	DRV.DISMODE controls the behavior of the <i>drv.dis</i> command issued through WorkBench, terminal, or fieldbus. Consult the <i>AKD User Guide</i> for configuring.
0	Disable axis immediately, if velocity drops below threshold <i>CS.VTHRESH</i> or timeout occurs brake is closed. Category 0 stop according to IEC 60204(=> p. 51).
2	Use controlled stop to disable drive, if velocity drops below threshold <i>CS.VTHRESH</i> or time-out occurs brake is closed. Category 1 stop according to IEC 60204(=> p. 51).

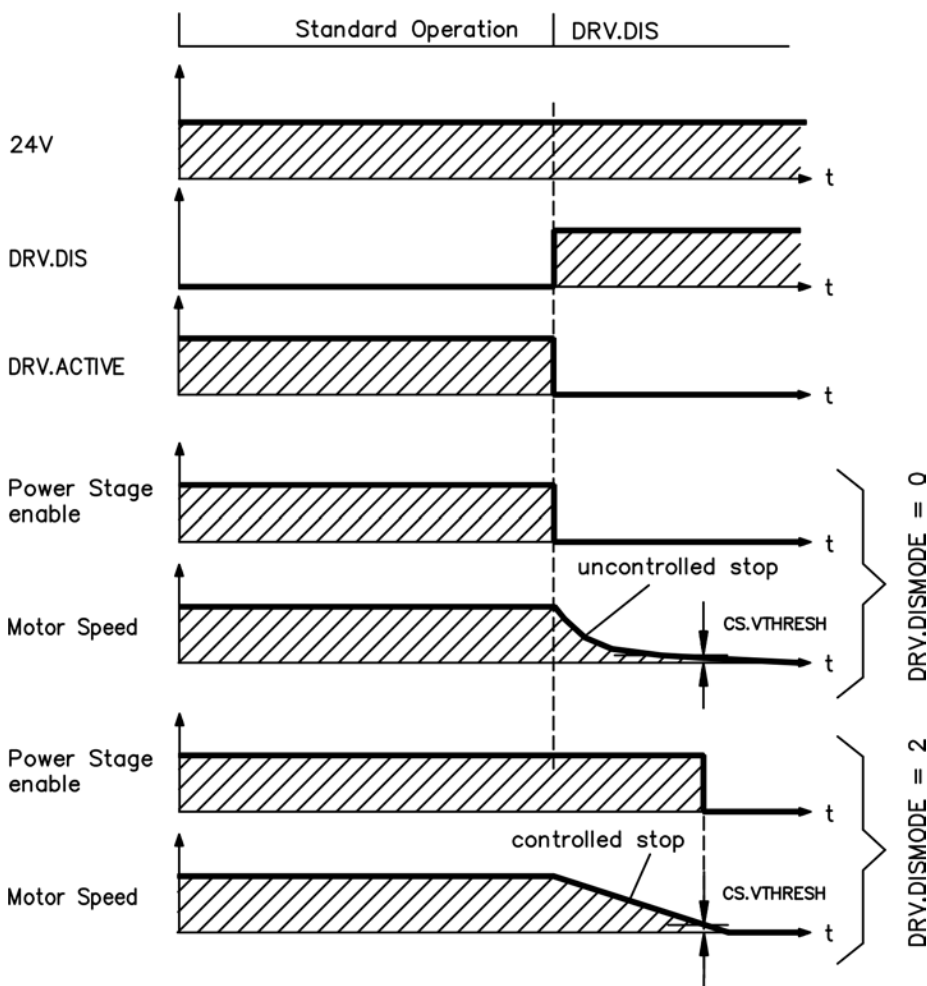

If velocity drops below threshold *CS.VTHRESH* or timeout occurs brake is closed (=> p. 93).

6.15.2.2 Switch-off behavior using a digital input (controlled stop)

This is a category 2 stop according to IEC 60204 (=> p. 51).

A digital input can be configured to bring the motor to a controlled stop and then disable the drive and apply the holding brake.(if present). See the *AKD User Guide* for information on configuring Digital Inputs.

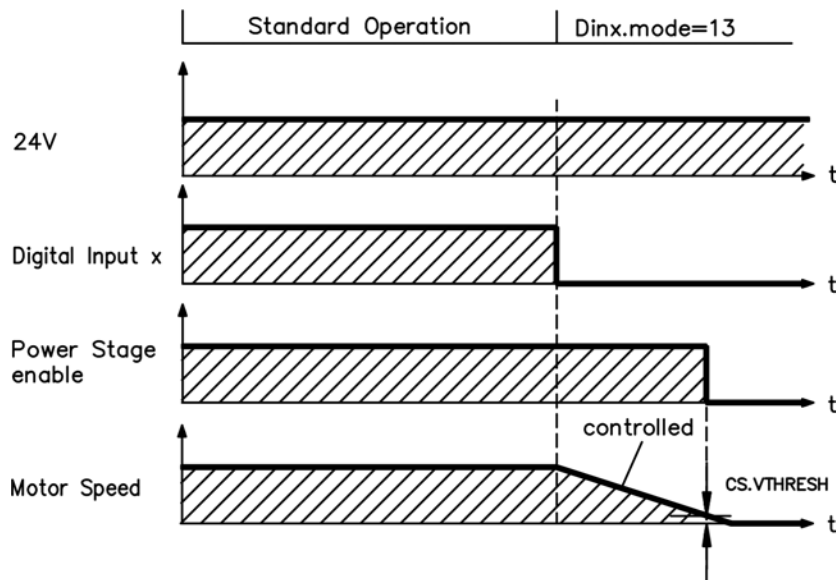

If velocity drops below threshold *CS.VTHRESH* or timeout occurs brake is closed (=> p. 93).

6.15.2.3 Switch-off behavior using HW Enable input (uncontrolled stop)

This is a category 0 stop according to IEC 60204 (=> p. 51).

The hardware enable input disables the power stage immediately.

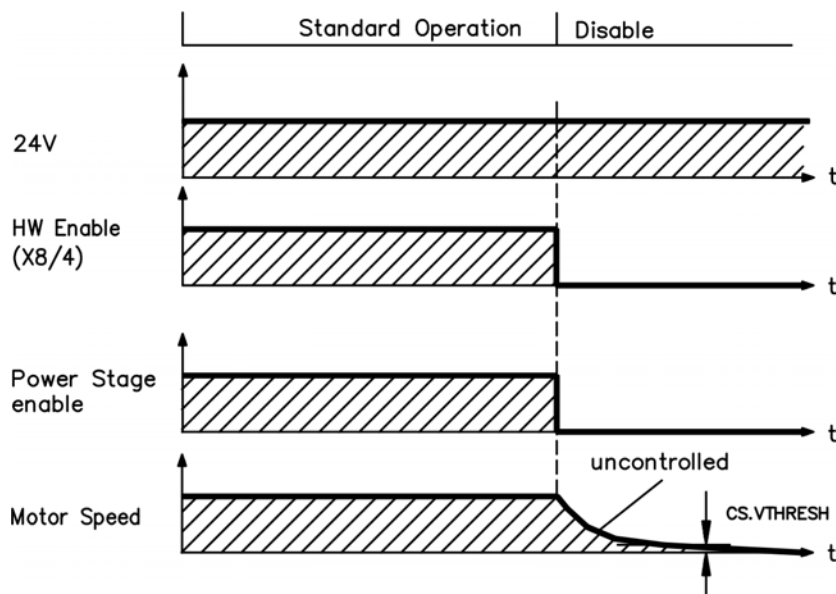

If velocity drops below threshold *CS.VTHRESH* or timeout occurs brake is closed (=> p. 93).

6.15.2.4 Switch-off behavior in the event of a fault

The behavior of the drive always depends on the fault type and the setting of a number of different parameters (DRV.DISMODE, VBUS.UVFTHRESH, CS.VTHRESH, and others; see the *AKD User Guide* or *WorkBench* help for more details). See the *Drive Fault and Warning Messages and Remedies* section of the *AKD User Guide* for a table describing the specific behavior of each fault.

The following pages show examples for the possible fault behaviors.

Switch-off behavior for faults that cause an immediate power stage disable

This is a category 0 stop according to IEC 60204 (=> p. 51).

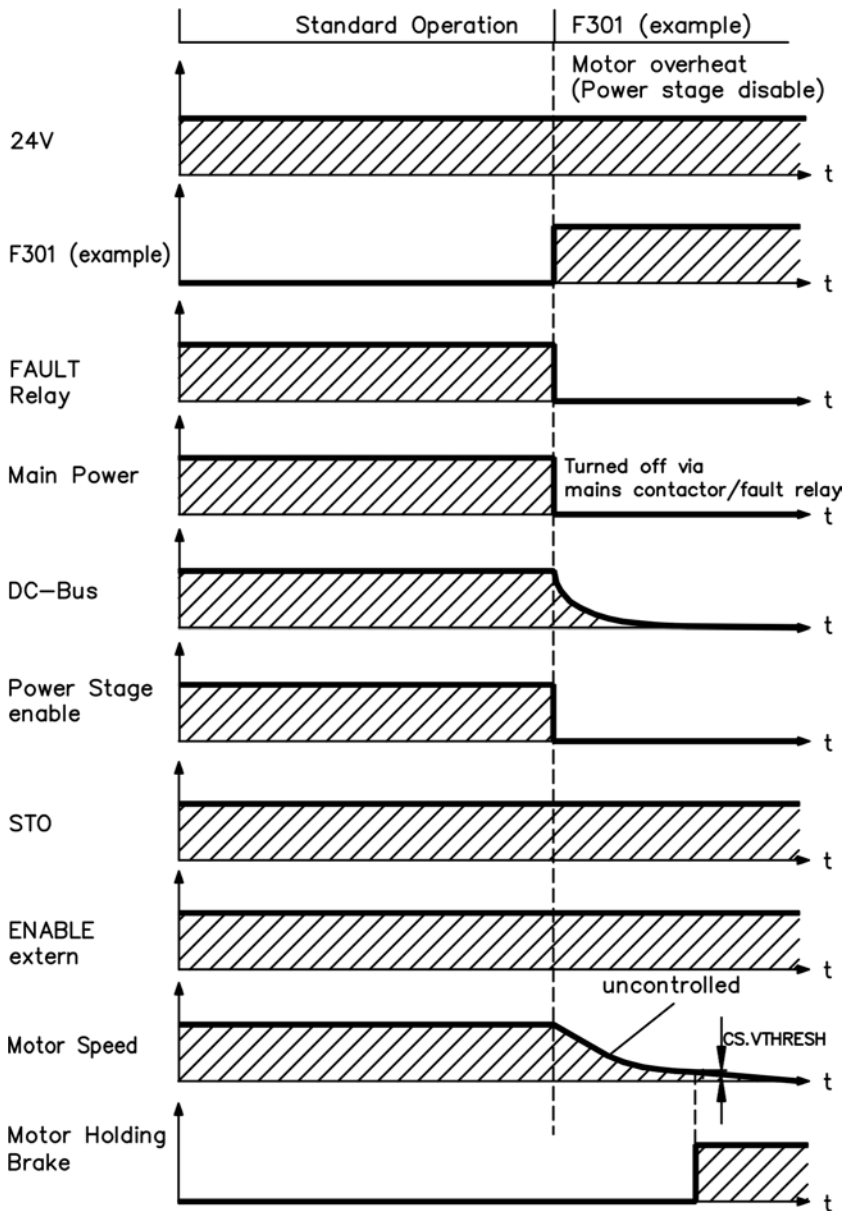

If velocity drops below threshold $CS.VTHRESH$ or timeout occurs brake is closed (=> p. 93).

Switch-off behavior for faults that cause dynamic braking

This is a category 0 stop according to IEC 60204 (=> p. 51).

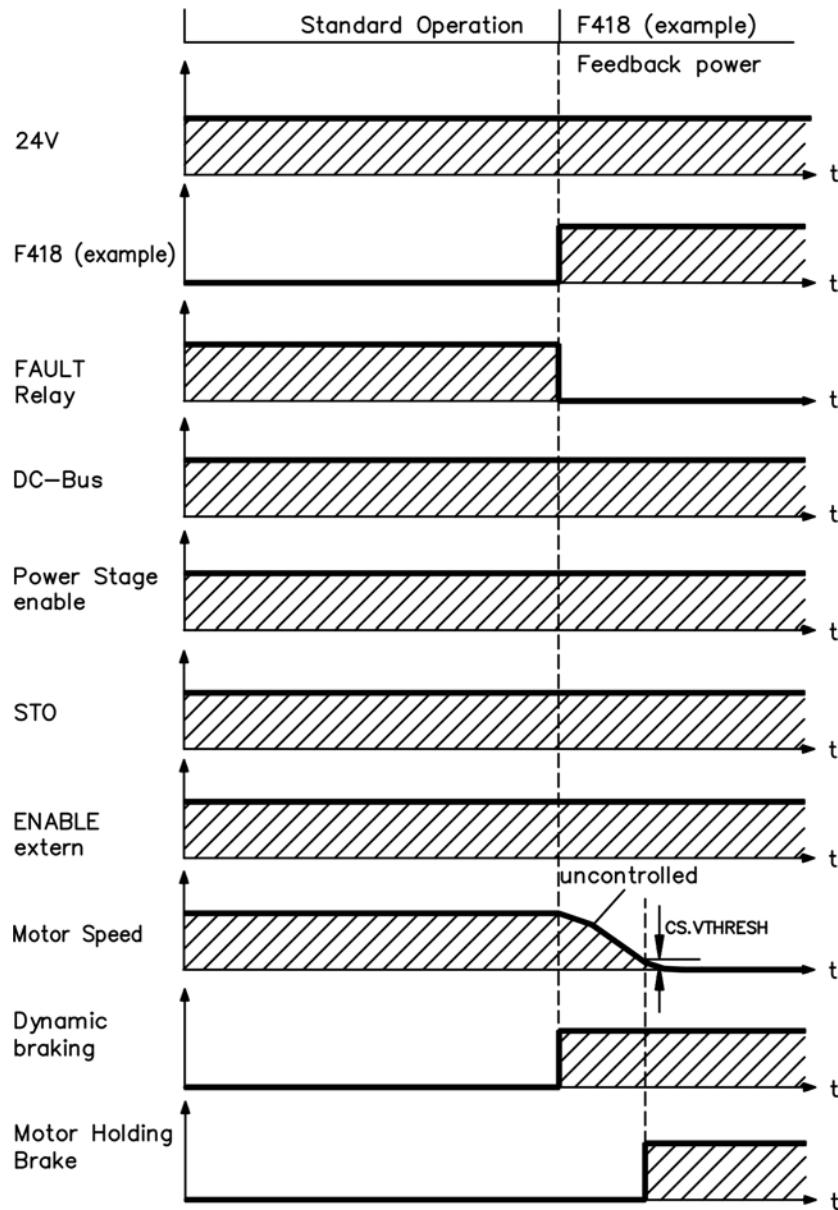

If velocity drops below threshold *CS.VTHRESH* or timeout occurs brake is closed (=> p. 93).

Switch-off behavior for faults that cause a controlled stop

This is a category 1 stop according to IEC 60204 (=> p. 51).

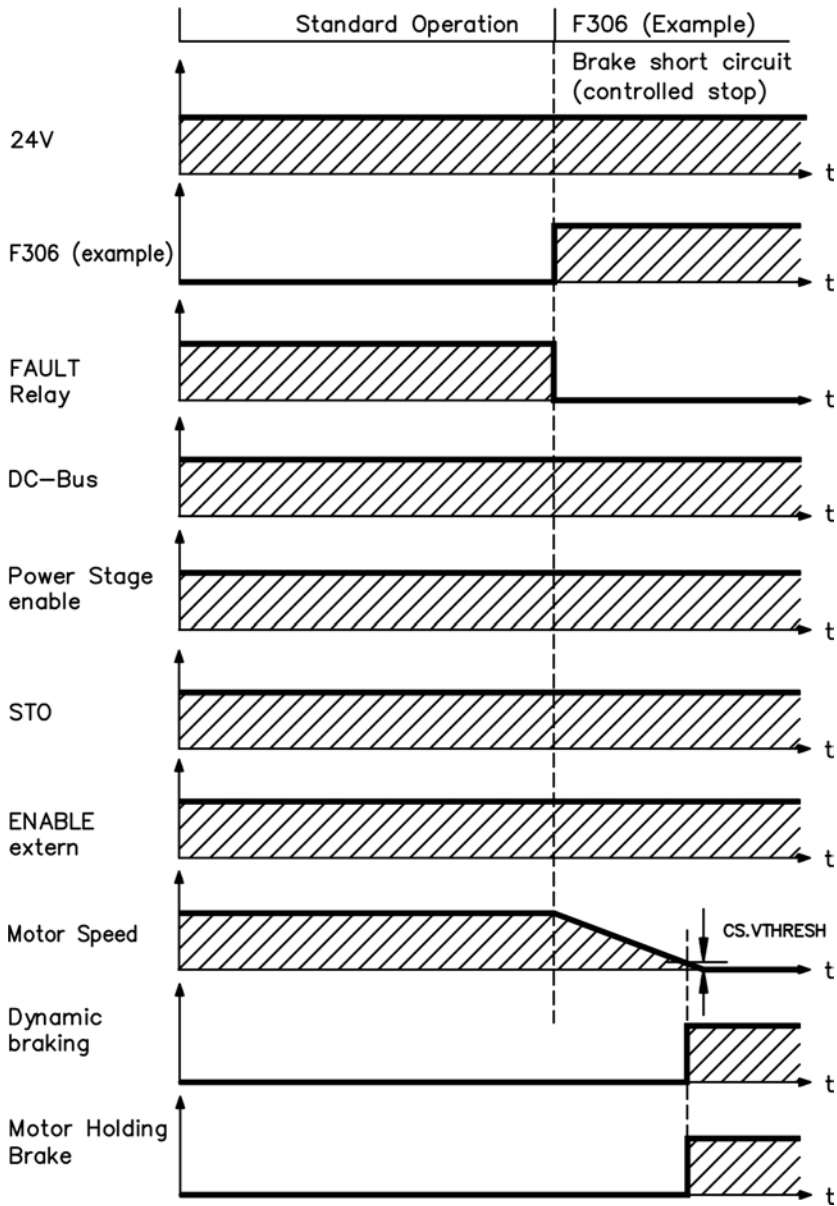

If velocity drops below threshold $CS.VTHRESH$ or timeout occurs brake is closed (=> p. 93).

6.16 Stop-/Emergency Stop- Standards

NOTE

With the personnel safe, approved restart lock STO (=> p. 53) the drive can be secured on standstill (torque-free) using its internal electronics so that even when power is being supplied, the drive shaft is protected against unintentional restart (IEC 61508 SIL 2).

NOTE

If the "Safety" option card is integrated, it provides safe drive functions in accordance with IEC 61800-5-2 (in process)

6.16.1 Stop: Standards

The stop function shuts down the machine in normal operation. The following stop functions are defined by IEC 60204:

- Category 0:
Shut-down by immediate switching-off the energy supply to the drive machinery (this is an uncontrolled shut-down).
- Category 1:
A controlled shut-down, whereby the energy supply to the drive machinery is maintained to perform the shut-down, and the energy supply is only interrupted when the shut-down has been completed.
- Category 2:
A controlled shut-down, whereby the energy supply to the drive machinery is maintained.

NOTE

The parameter **DRV.DISMODE** must be set to 2 to implement the different stop categories. Consult the User Guide for configuring the parameter.

The stop category must be determined by a risk evaluation of the machine. In addition, suitable means must be provided to guarantee a reliable shut-down.

Category 0 and Category 1 stops must be operable independently of the operating mode, whereby a Category 0 stop must have priority. Stop functions must be implemented by disconnection of the appropriate circuitry and have priority over assigned start functions.

If necessary, provision must be made for the connection of protective devices and lock-outs. If applicable, the stop function must signal its status to the control logic. A reset of the stop function must not create a hazardous situation.

6.16.2 Emergency Stop: Standards

The emergency stop function is used for the fastest possible shutdown of the machine in a dangerous situation. The emergency stop function can be triggered by the actions of a single person. It must be fully functional and available at all times. The user must understand instantly how to operate this mechanism (without consulting references or instructions).

The emergency stop function is defined by IEC 60204.

In addition to the requirements for stop, the emergency stop must fulfil the following requirements:

- Emergency stop must have priority over all other functions and controls in all operating situations.
- The energy supply to any drive machinery that could cause dangerous situations must be switched off as fast as possible, without causing any further hazards (such as by using mechanical latching devices that do not require an external supply of energy or by counter-current braking in Stop Category 1).
- The reset must not initiate a restart.

If necessary, provision must be made for the additional connection of emergency stop devices (see IEC 60204, "Requirements for emergency stop devices"). The emergency stop must be effective as a stop of either Category 0 or Category 1. The emergency stop category must be determined by a risk evaluation of the machine.

Category 0

Only hard-wired, electromechanical components may be used for the Category 0 Emergency Stop function. It must not be triggered using switching logic (hardware or software), by transferring commands via a communication network, or via a data link.

The drive must be shut down using an electromechanical circuit. If the connected servomotor has an integrated brake, this brake must always be controlled by an electromechanical circuit as well.

Category 1

With the Category 1 emergency stop function, the final power supply switch-off must be ensured by using electromechanical components. Additional external emergency stop equipment may be connected. The motor is stopped by interrupting the mains supply and using controlled electronic braking. The 24 V supply for the drive must remain constant. The issue of which circuit should be used highly depends on the requirements of the application at hand.

In most servomotors, a brake has only the function of a holding brake. To ensure an emergency stop function, the braking torque that is required must be checked. If the holding brake fulfills the dynamic requirements, it must be taken into account that this application will cause increased wear.

NOTE

The parameter **DRV.DISMODE** must be set to 2 to implement the different stop categories. Consult the *AKD User Guide* for configuring the parameter.

6.17 Safe Torque Off (STO)

An additional digital input (STO) releases the power output stage of the drive as long as a 24 V signal is applied to this input. If the STO input goes open-circuit, then power will no longer be supplied to the motor, and the drive will lose all torque and coast to a stop.

Input STO (X1/3)

- Floating, reference ground is GND
- 24 V \pm 10%, 20 mA

NOTE This input is not compatible with IEC 61131-2.

You can thus achieve a restart lock-out for personnel safety by using the STO input in conjunction with an external safety circuit.

Advantages of the STO function:

- The DC bus link remains charged up, since the mains supply line remains active.
- Only low voltages are switched, so there is no contact wear.
- Very little wiring is required.

The STO safety concept is certified. The safety circuit concept for realizing the safety function "Safe Torque Off" in the drive is suited for SIL 2 according to EN 61800-5-2 and PL d / CAT 3 according to ISO 13849-1.

6.17.1 Safety characteristic data

The subsystems (AKD) are totally described for safety technics with the characteristic data :

Device	Operation Mode	EN 13849-1	EN 62061	PFH [1/h]	SFF[%]
STO	STO single channel	PL d, CAT 3	SIL 2	0	20

6.17.2 Safety instructions

⚠ WARNING	Drives with a suspended load must have an additional safe mechanical blocking (for instance, by a motor-holding brake). The drive cannot hold the load when STO is active. Serious injury could result when load is not properly blocked.
⚠ CAUTION	If the safety function STO is automatically activated by a control system, then make sure that the output of the control is monitored for possible malfunction. The monitoring can be used to prevent a faulty output from unintentionally activating the STO function. Since the STO function is a single-channel system, erroneous engaging will not be recognized.
⚠ CAUTION	It is not possible to perform a controlled brake of the drive controlled STO-Enable is off. If controlled braking before the use of the STO function is necessary, the drive must be braked and the input STO must be separated from +24 V time-delayed.
⚠ CAUTION	The STO function does not provide an electrical separation from the power output. If access to the motor power terminals is necessary, the drive must be disconnected from mains supply considering the discharging time of the intermediate circuit. There is a danger of electrical shock and personnel injury.
NOTICE	Use the following functional sequence when the STO function is used: <ol style="list-style-type: none"> 1. Brake the drive in a controlled manner (speed setpoint = 0 V). 2. When speed = 0 rpm, disable the drive (enable = 0 V). 3. If a suspended load is present, block the drive mechanically. 4. Activate the STO function.

6.17.3 Use as directed

The STO function is exclusively intended to provide safety for personnel by preventing the restart of a system. To achieve this personnel safety, the wiring of the safety circuits must meet the safety requirements of IEC 60204, ISO 12100 and ISO 13849.

6.17.4 Prohibited Use

The STO function must not be used if the drive is to be made inactive for the following reasons:

1. Cleaning, maintenance and repair operations, long inoperative periods. In such cases, the entire system should be disconnected from the supply and secured (main switch).
2. Emergency-stop situations. In an emergency-stop situation, the main contactor is switched off (by the emergency-stop button).

6.17.5 Technical data and pinning

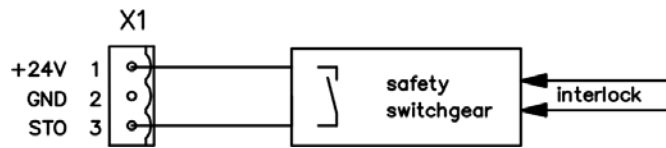

Pin	Signal	Description
1	+24	+24 Vdc Auxiliary voltage
2	GND	24V Supply GND
3	STO	STO enable (Safe Torque Off)

6.17.6 Enclosure

Since the drive meets IP20, you must select an enclosure that permits safe operation of the drive. The enclosure must at least meet IP54 .

6.17.7 Wiring

If you are wiring leads that are outside the specified enclosure (IP54), the cables must be laid durably (firmly), protected from outside damage (e.g. laying in a cable duct), in different sheathed cables or protected individually by grounding connection.

Wiring remaining within the specified enclosure must meet the requirements of the standard IEC 60204-1.

6.17.8 Functional description

When STO function (Safe Torque Off) is not needed, then the input STO must be connected directly with +24 V. The function is then bypassed and cannot be used. In case of use of the STO function the input STO must be connected to the exit of a security control or a safety relay, which at least meets the requirements of PLd, CAT 3 according to ISO 13849 (connection diagram: => p. 57). Possible states of the drive referring to STO function:

STO	ENABLE	Display	Motor has Torque	Safety SIL 2
0 V	0 V	n602	no	yes
0 V	+24 V	F602	no	yes
+24 V	0 V	opmode	no	no
+24 V	+24 V	opmode with 'dot'	yes	no

When STO function is engaged during operation by separating input STO from 24 V, the motor slows down without control and the drive displays the fault F602.

CAUTION It is not possible to perform a controlled brake of the drive controlled STO-Enable is off. If controlled braking before the use of the STO function is necessary, the drive must be braked and the input STO must be separated from +24 V time-delayed.

CAUTION The STO function does not provide an electrical separation from the power output. If access to the motor power terminals is necessary, the drive must be disconnected from mains supply considering the discharging time of the intermediate circuit. There is a danger of electrical shock and personnel injury.

Since the STO function is a single-channel system, erroneous engaging will not be recognized. When wiring the input STO within one enclosure it must be paid attention to the fact that the used cables and the enclosure meet the requirements of IEC 60204-1. If you are wiring leads outside the specified enclosure, then the cables must be laid durably and protected from outside damage.

6.17.8.1 Signal diagram (sequence)

The diagram below shows how to use STO function for a safe drive stop and fault free operation of the drive.

1. Brake the drive in a controlled manner (speed setpoint = 0 V).
2. When speed = 0 rpm, disable the drive (Enable = 0 V).
3. Activate the STO function (STO = 0 V).

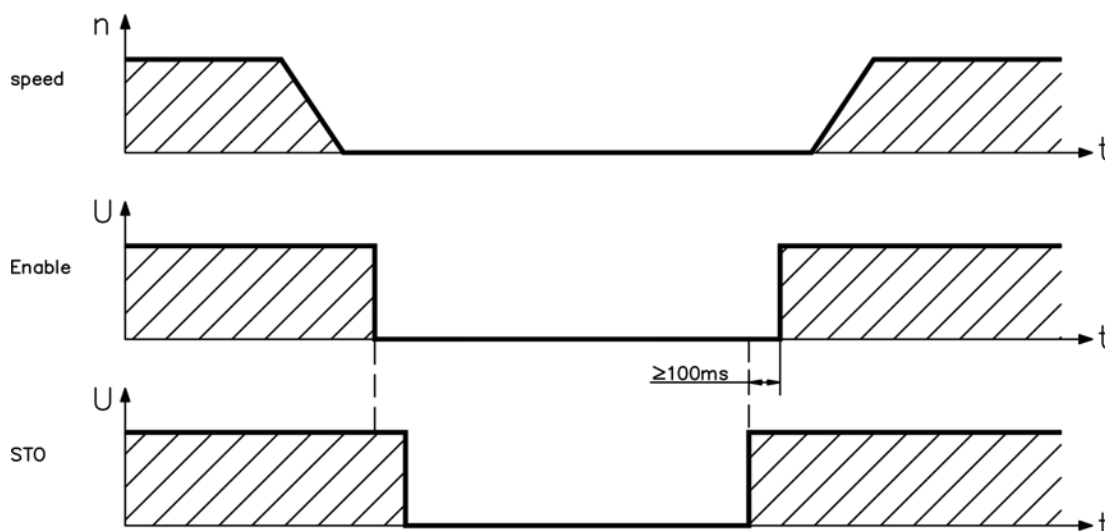

WARNING Suspended loads can set themselves in motion on motors without a brake, because the motor loses all torque when STO function is engaged (STO open and/or 0 V). Use motors with a built-in holding brake.

6.17.8.2 Control circuit (example)

The example shows a control circuit with two separated work areas connected to one emergency stop circuit (mains supply circuit: => p. 58). For each work area, "safe stop" of the drives is switched by a protective screen. The safety switchgears used in the example are manufactured by Pilz and fulfill at least the PLd according to ISO 13849-1 or SIL CL2 according to IEC 62061. Safety switchgears from other manufacturers may also be used.

NOTE Review the wiring instructions; => p. 55.

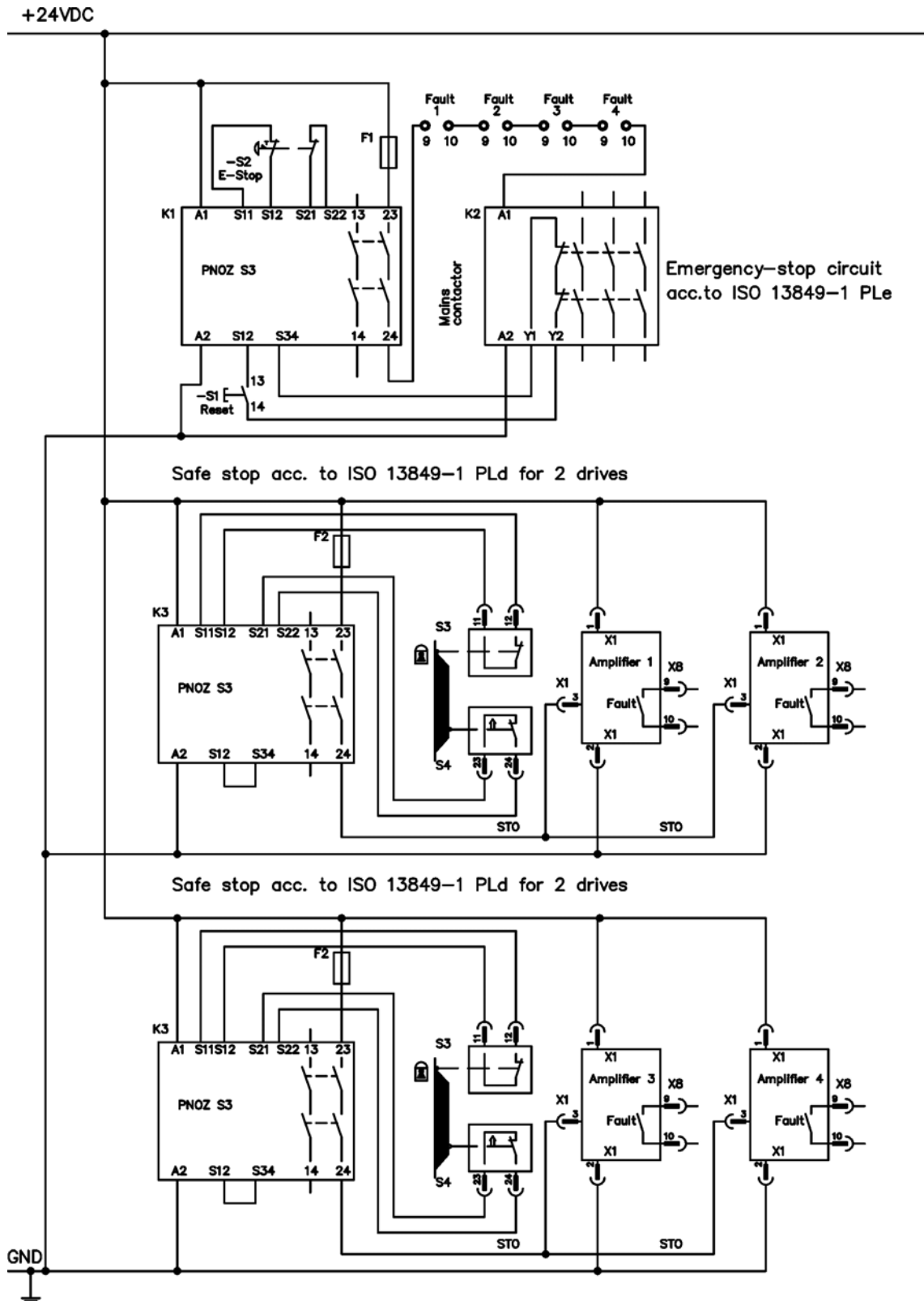

6.17.8.3 Functional test

⚠ CAUTION With initial starting and after each interference into the wiring of the drive or after exchange of one or several components of the drive the function of the restart lock must be tested.

First Method:

1. Stop drive, with setpoint 0 V, keep drive enabled.
DANGER: Do not enter hazardous area!
2. Activate the STO function for example by opening protective screen (voltage at X1/3 0 V).
3. The fault contact opens, the net contactor releases and the drive displays fault F602.

Second Method:

1. Stop all drives, with setpoint 0 V, disable drive.
2. Activate the STO function for example by opening protective screen (voltage at X1/3 0 V)
3. The drive displays warning n602.

6.17.8.4 Mains supply circuit (example)

Corresponding control circuit => p. 57.

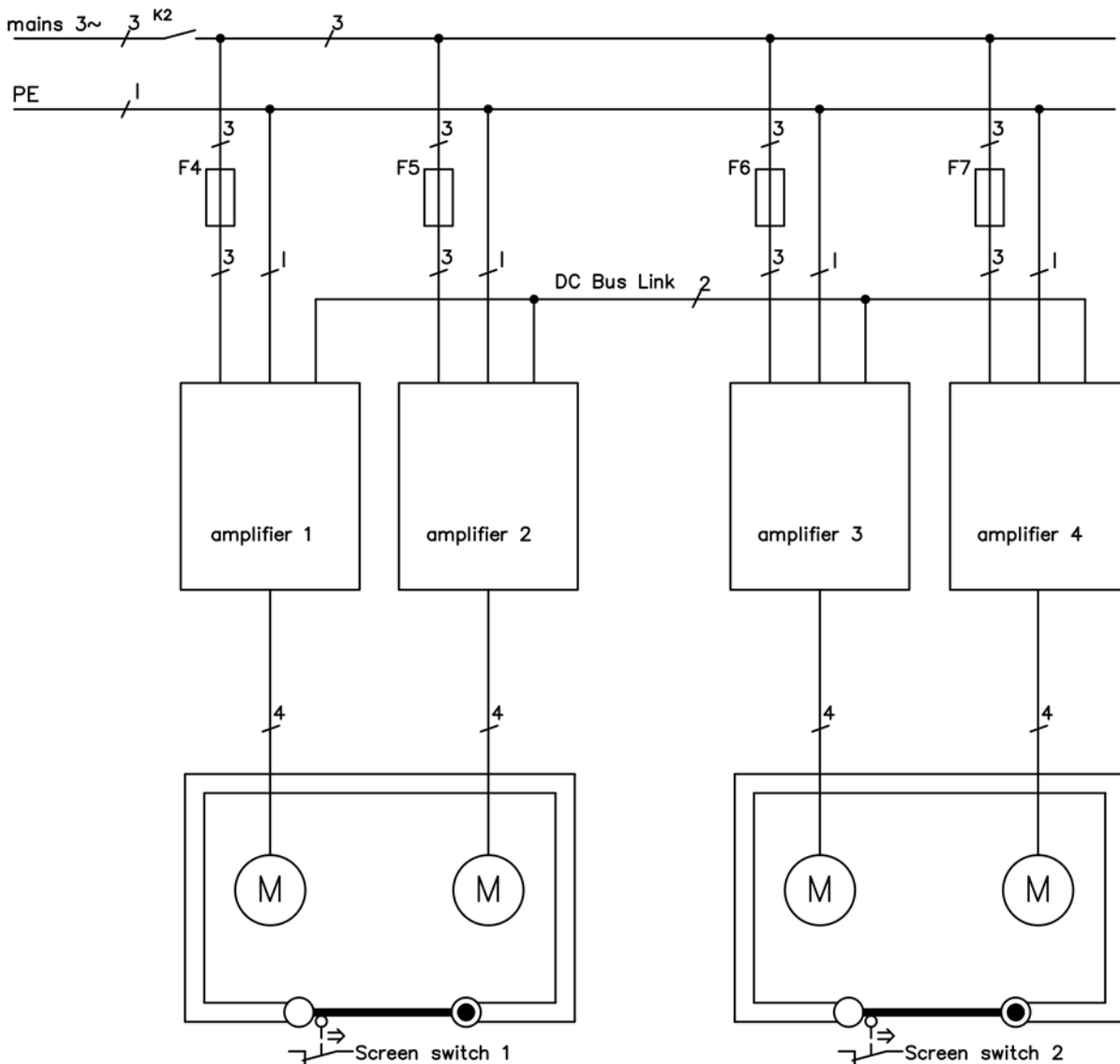

6.18 Shock-hazard Protection

6.18.1 Leakage Current

Leakage current via the PE conductor results from the combination of equipment and cable leakage currents. The leakage current frequency pattern includes a number of frequencies, whereby the residual-current circuit breakers definitively evaluate the 50 Hz current. For this reason, the leakage current cannot be measured using a conventional multimeter.

As a rule of thumb, the following assumption can be made for leakage current on our low-capacity cables at a mains voltage of 400 V, depending on the clock frequency of the output stage:

$I_{\text{leak}} = n \times 20 \text{ mA} + L \times 1 \text{ mA/m}$ at 8 kHz clock frequency at the output stage

$I_{\text{leak}} = n \times 20 \text{ mA} + L \times 2 \text{ mA/m}$ at a 16 kHz clock frequency at the output stage

(where I_{leak} =leakage current, n =number of drives, L =length of motor cable)

At other mains voltage ratings, the leakage current varies in proportion to the voltage.

Example: 2 x drives + a 25m motor cable at a clock frequency of 8 kHz:

$2 \times 20 \text{ mA} + 25 \text{ m} \times 1 \text{ mA/m} = 65 \text{ mA}$ leakage current.

NOTE

Since the leakage current to PE is more than 3.5 mA, in compliance with IEC61800-5-1 the PE connection must either be doubled or a connecting cable with a cross-section >10 mm² must be used. Use the PE terminal and the PE connection screws in order to fulfill this requirement.

The following measures can be used to minimize leakage currents:

- Reduce the length of the engine cable.
- Use low-capacity cables (=> p. 39).

6.18.2 Residual Current Protective Device (RCD)

In conformity with IEC 60364-4-41 – Regulations for installation and IEC 60204 – Electrical equipment of machinery, residual current protective devices (RCDs) can be used provided the requisite regulations are complied with.

The AKD is a 3-phase system with a B6 bridge. Therefore, RCDs which are sensitive to all currents must be used in order to detect any DC fault current. Refer to the chapter above for the rule of thumb for determining the leakage current.

Rated residual currents in the RCDs:

10 to 30 mA	Protection against "indirect contact" (personal fire protection) for stationary and mobile equipment, as well as for "direct contact".
50 to 300 mA	Protection against "indirect contact" (personal fire protection) for stationary equipment

NOTE

Recommendation: In order to protect against direct contact (with motor cables shorter than 5 m) Kollmorgen™ recommends that each drive be protected individually using a 30 mA RCD which is sensitive to all currents.

If you use a selective RCD, the more intelligent evaluation process will prevent spurious tripping of the RCD.

6.18.3 Isolating Transformers

When protection against indirect contact is absolutely essential despite a higher leakage current, or when an alternative form of shock-hazard protection is sought, the AKD can also be operated via an isolating transformer (schematic connection => p. 84).

A ground-leakage monitor can be used to monitor for short circuits.

NOTE

Keep the length of wiring between the transformer and the drive as short as possible.

7 Mechanical Installation

7.1 Safety Instructions.....	61
7.2 Guide to Mechanical Installation.....	61
7.3 Control Cabinet Layout AKD-xzzz06.....	62
7.4 Control Cabinet Layout AKD-xzzz07.....	63
7.5 Dimensions, AKD-x00306 to x00606.....	64
7.6 Dimensions, AKD-x01206.....	65
7.7 Dimensions, AKD-x02406.....	66
7.8 Dimensions, AKDx00307 to 01207.....	67
7.9 Dimensions, AKDx02407.....	68

7.1 Safety Instructions

⚠ CAUTION	There is a danger of electrical shock by high EMC level which could result in injury, if the drive (or the motor) is not properly EMC-grounded. Do not use painted (i.e. non-conductive) mounting plates.
NOTICE	Protect the drive from impermissible stresses. In particular, do not let any components become bent or any insulation distances altered during transport and handling. Avoid contact with electronic components and contacts.
NOTICE	The drive will switch itself off in case of overheating. Ensure that there is an adequate flow of cool, filtered air into the bottom of the control cabinet, or use a heat exchanger ("Ambient Conditions, Ventilation, and Mounting Position" => p. 33).
NOTICE	Do not mount devices that produce magnetic fields directly beside the drive. Strong magnetic fields can directly affect internal components. Install devices which produce magnetic field with distance to the drives and/or shield the magnetic fields.

7.2 Guide to Mechanical Installation

The following tools are required (at a minimum) to install the AKD; your specific installation may require additional tools:

- M4 hexagon socket-cap screws (ISO 4762)
- 3 mm T-handle Allen key
- No. 2 Phillips head screwdriver
- Small slotted screwdriver

Install the drive unit as follows:

1. Prepare the site.
Mount the drive in a closed control cabinet (=> p. 33). The site must be free from conductive or corrosive materials. For the mounting position in the cabinet => p. 62 respectively => p. 63.
2. Check ventilation.
Check that the ventilation of the drive is unimpeded, and keep within the permitted ambient temperature => p. 33. Keep the required space clearance above and below the drive => p. 62 respectively => p. 63.
3. Check cooling system.
If cooling systems are used for the control cabinet, position the cooling system so that condensation water cannot drip onto the drive or peripheral devices.
4. Mount the drive.
Assemble the drive and power supply near each other on the conductive, grounded mounting plate in the cabinet.
5. Ground the drive.
For EMC-compliant shielding and grounding, => p. 80. Ground the mounting plate, motor housing and CNC-GND of the control system. For notes on connection techniques, => p. 72.

7.3 Control Cabinet Layout AKD-xzzz06

Material: M4 hexagon socket screws to ISO 4762, 3 mm T-handle Allen key

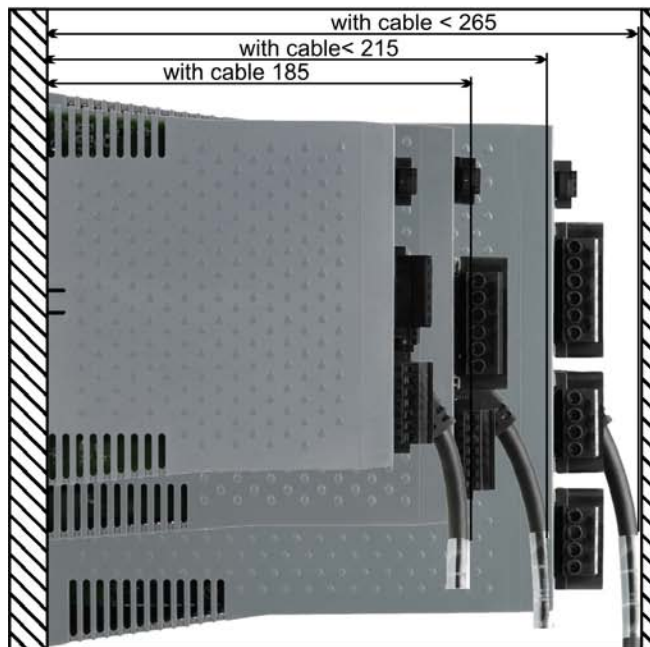
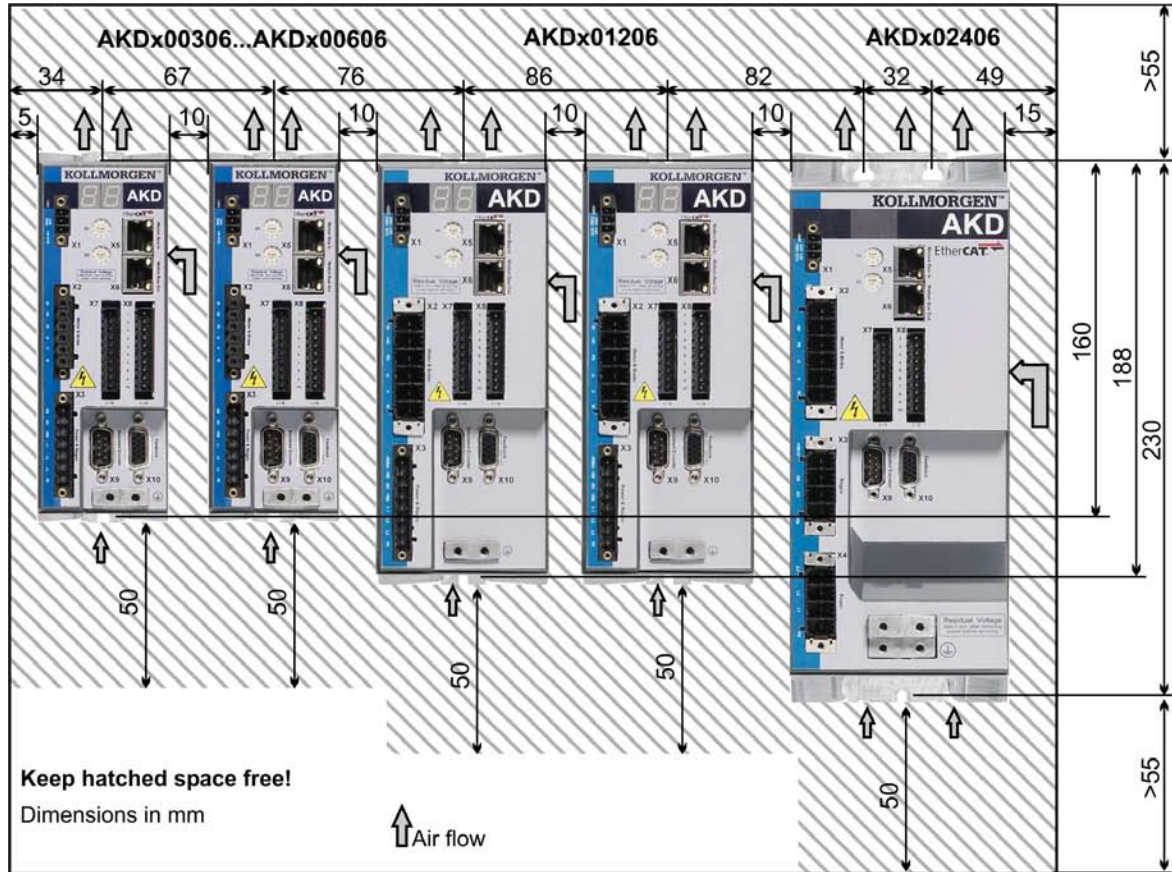

7.4 Control Cabinet Layout AKD-xzzz07

Material: M4 hexagon socket screws to ISO 4762, 3 mm T-handle Allen key

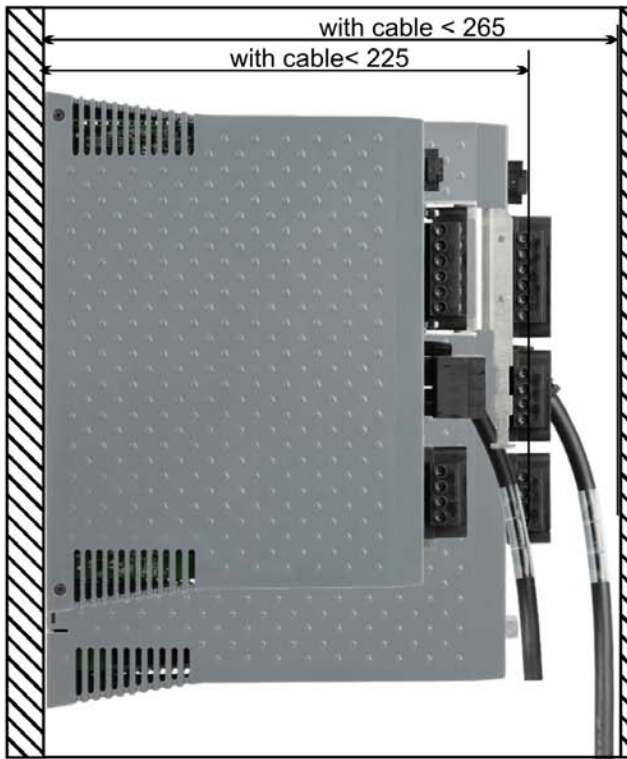
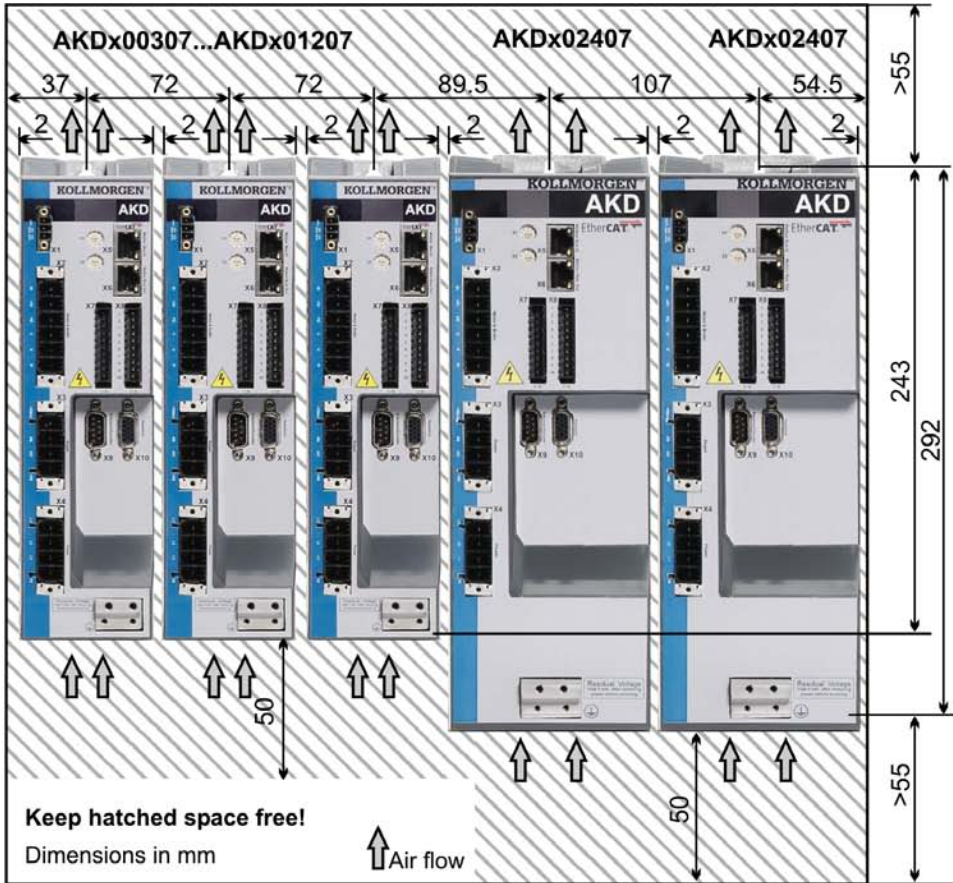

7.5 Dimensions, AKD-x00306 to x00606

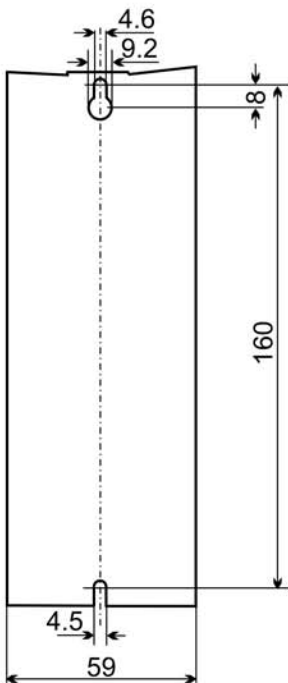
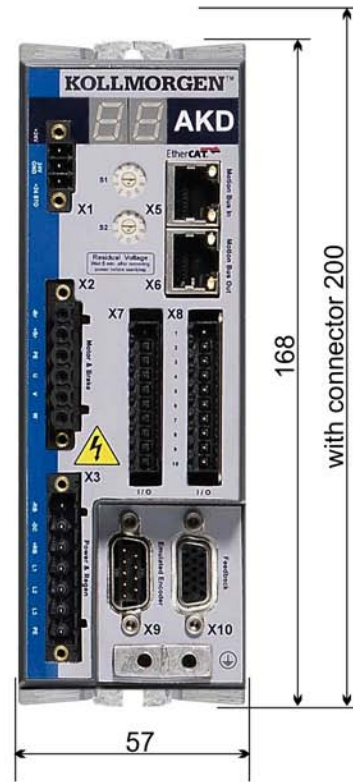

All Dimensions in mm

7.6 Dimensions, AKD-x01206

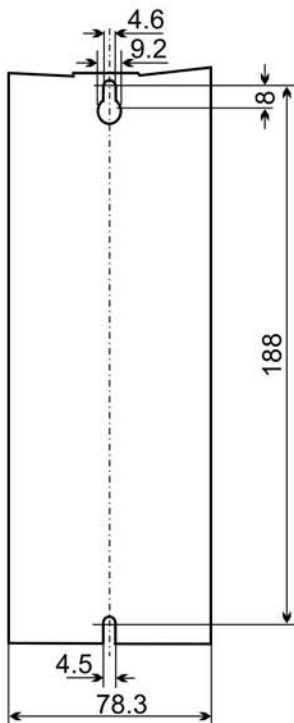

All dimensions in mm

7.7 Dimensions, AKD-x02406

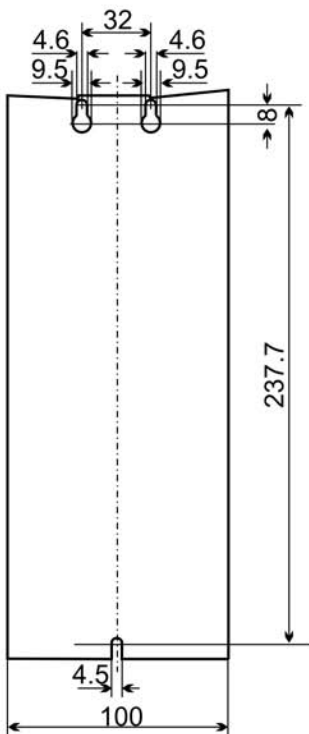
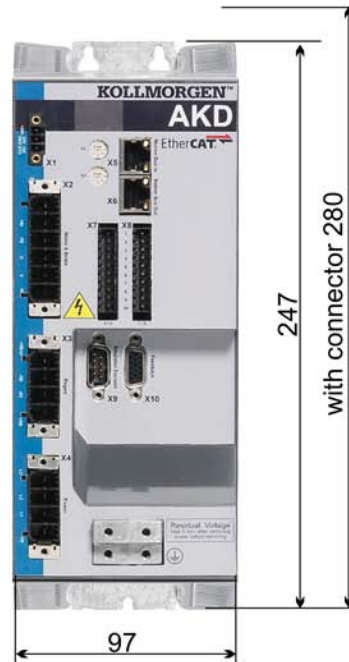

Dimensions in mm

7.8 Dimensions, AKDx00307 to 01207

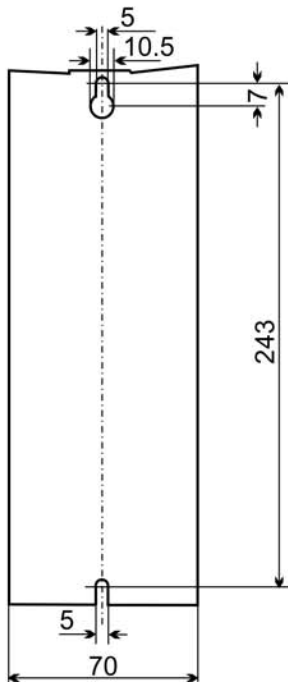
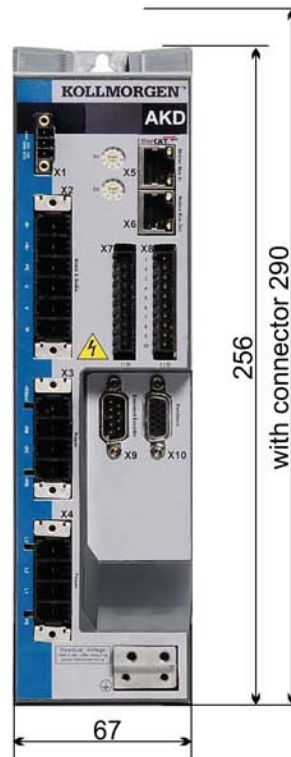

All Dimensions in mm

7.9 Dimensions, AKDx02407

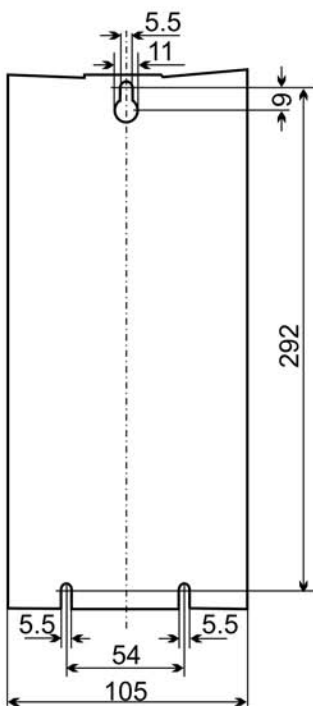
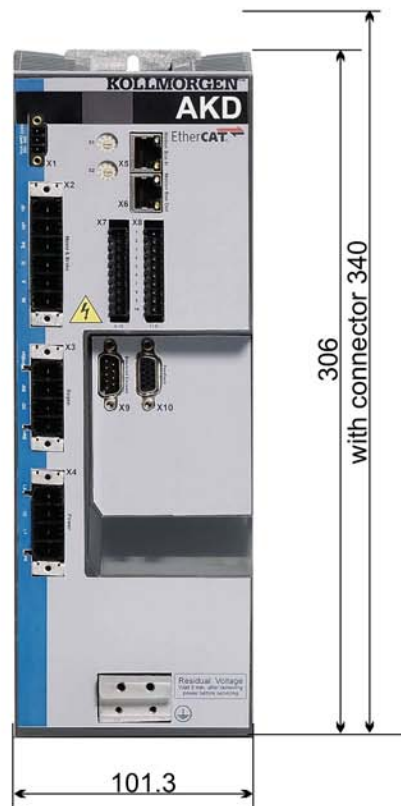

All Dimensions in mm

8 Electrical Installation

8.1	Safety Instructions.....	70
8.2	Guide to electrical installation.....	71
8.3	Wiring.....	72
8.4	Components of a servosystem.....	73
8.5	Connector Assignments, AKD-x00306 to x00606.....	75
8.6	Connector Assignments, AKD-x01206.....	75
8.7	Connector Assignments, AKD-x02406 and AKD-xzzz07.....	76
8.8	Connection Diagram, AKD-x00306 to x00606.....	77
8.9	Connection Diagram, AKD-x01206.....	78
8.10	Connection Diagram, AKD-x02406 and AKD-xzzz07.....	79
8.11	EMI Noise Reduction.....	80
8.12	Electrical Supply Connection.....	84
8.13	Motor Connection.....	91
8.14	Feedback Connection.....	94
8.15	Electronic gearing, Master-slave operation.....	104
8.16	I/O Connection.....	110
8.17	Service Interface (X11).....	118
8.18	CANbus Interface (X12/X13).....	120
8.19	Motion Bus Interface (X5/X6).....	123

8.1 Safety Instructions

⚠ DANGER Never remove electrical connections to the drive while it is live. There is a danger of electrical arcing with damage to contacts and serious personal injury. Wait at least seven minutes after disconnecting the drive from the main supply power before touching potentially live sections of the equipment (e.g. contacts) or undoing any connections.

Capacitors can still have dangerous voltages present up to 7 minutes after switching off the supply power. To be sure, measure the voltage in the DC bus link and wait until it has fallen below 40 V.

Control and power connections can still be live, even if the motor is not rotating.

NOTICE Wrong mains voltage, unsuitable motor or wrong wiring will damage the drive. Check the combination of drive and motor. Compare the rated voltage and current of the units. Implement the wiring according to the connection diagram: => p. 77. Make sure that the maximum permissible rated voltage at the terminals L1, L2, L3 or +DC, -DC is not exceeded by more than 10% even in the most unfavorable circumstances (see IEC 60204-1).

NOTICE Excessively high external fusing will endanger cables and devices. The fusing of the AC supply input and 24 V supply must be installed by the user, best values => p. 37. Hints for use of Residual-current circuit breakers (RCD) => p. 59.

NOTICE The drive status must be monitored by the PLC to acknowledge critical situations. Wire the FAULT contact in series into the emergency stop circuit of the installation. The emergency stop circuit must operate the supply contactor.

NOTE It is permissible to use the setup software to alter the settings of the drive. Any other alterations will invalidate the warranty.

8.2 Guide to electrical installation

Install the drive electrical system as follows:

1. Select cables in accordance with IEC 60204 => p. 39.
2. Install shielding and ground the drive.

For EMC-compliant shielding and grounding, => p. 80, "EMI Noise Reduction" (=> p. 80) & "Connection Diagram, AKD-x00306 to x00606" (=> p. 77) and following. Ground the mounting plate, motor housing and CNC-GND of the control system.

3. Wire the drive and connectors. Observe the "Recommendations for EMI noise reduction": => p. 80
 - Wire the FAULT contact in series into the emergency stop circuit of the system.
 - Connect the digital control inputs and outputs.
 - Connect up analog ground (also if fieldbuses are used).
 - Connect the analog input source, if required.
 - Connect the feedback device.
 - Connect the hardware option.
 - Connect the motor cable
 - Connect shielding at both ends. Use a motor choke if cable > 25m.
 - Connect motor-holding brake, connect shielding at both ends.
 - If required, connect the external brake resistor (with fusing).
 - Connect the auxiliary supply (maximum permissible voltage values see electrical data (=> p. 34 or => p. 35).
 - Connect the mains filter with AKD-xzzz06 (shielded lines between filter and drive).
 - Connect the main electrical supply. Check maximum permitted voltage value (=> p. 34 or => p. 35). Check proper use of residual-current circuit breakers (RCD); => p. 59
 - Connect the PC (=> p. 118) for setting up the drive.
4. Check the wiring against the wiring diagrams.

8.3 Wiring

The installation procedure is described as an example. A different procedure may be appropriate or necessary, depending on the application of the equipment. Kollmorgen™ can provide training courses for this procedure upon request.

⚠ DANGER There is a danger of electrical arcing which can cause serious personnel injury. Only install and wire the equipment when it is not live, that is, when neither the electrical supply nor the 24 V auxiliary voltage nor the supply voltages of any other connected equipment is switched on. Make sure that the cabinet is safely disconnected (for instance, with a lock-out and warning signs). The individual voltages are switched on for the first time during setup.

⚠ CAUTION Only professional staff who are qualified in electrical engineering are allowed to install the drive. Wires with color green with one or more yellow stripes must not be used other than for protective earth (PE) wiring.

NOTE The ground symbol, which you will find in all the wiring diagrams, indicates that you must take care to provide an electrically conductive connection with the largest feasible surface area between the unit indicated and the mounting plate in the control cabinet. This connection is for the effective grounding of HF interference, and must not be confused with the PE-symbol (PE = protective earth, safety measure as per IEC 60204).

NOTE Use the following connection diagrams:

Overview (all connections):	
- AKD-x00306 to x00606	=> p. 77
- AKD-x01206	=> p. 78
- AKD-x02406 and xzzz07	=> p. 79
Shielding:	=> p. 87
Mains power:	=> p. 91
Motor:	=> p. 94
Feedback:	=> p. 94
Electronic gearing:	=> p. 104
Encoder emulation:	=> p. 107
Digital and analog inputs and outputs:	=> p. 110
Service interface:	=> p. 118
CANbus interface:	=> p. 120
Motion bus interface:	=> p. 123
Hardware options:	=> p. 140

8.4 Components of a servosystem

With AKD-xzzz06

NOTE Cables drawn bold are shielded. Electrical ground is drawn with dash-dotted lines. Optional devices are connected with dashed lines to the drive. The required accessories are described in the accessories manual.

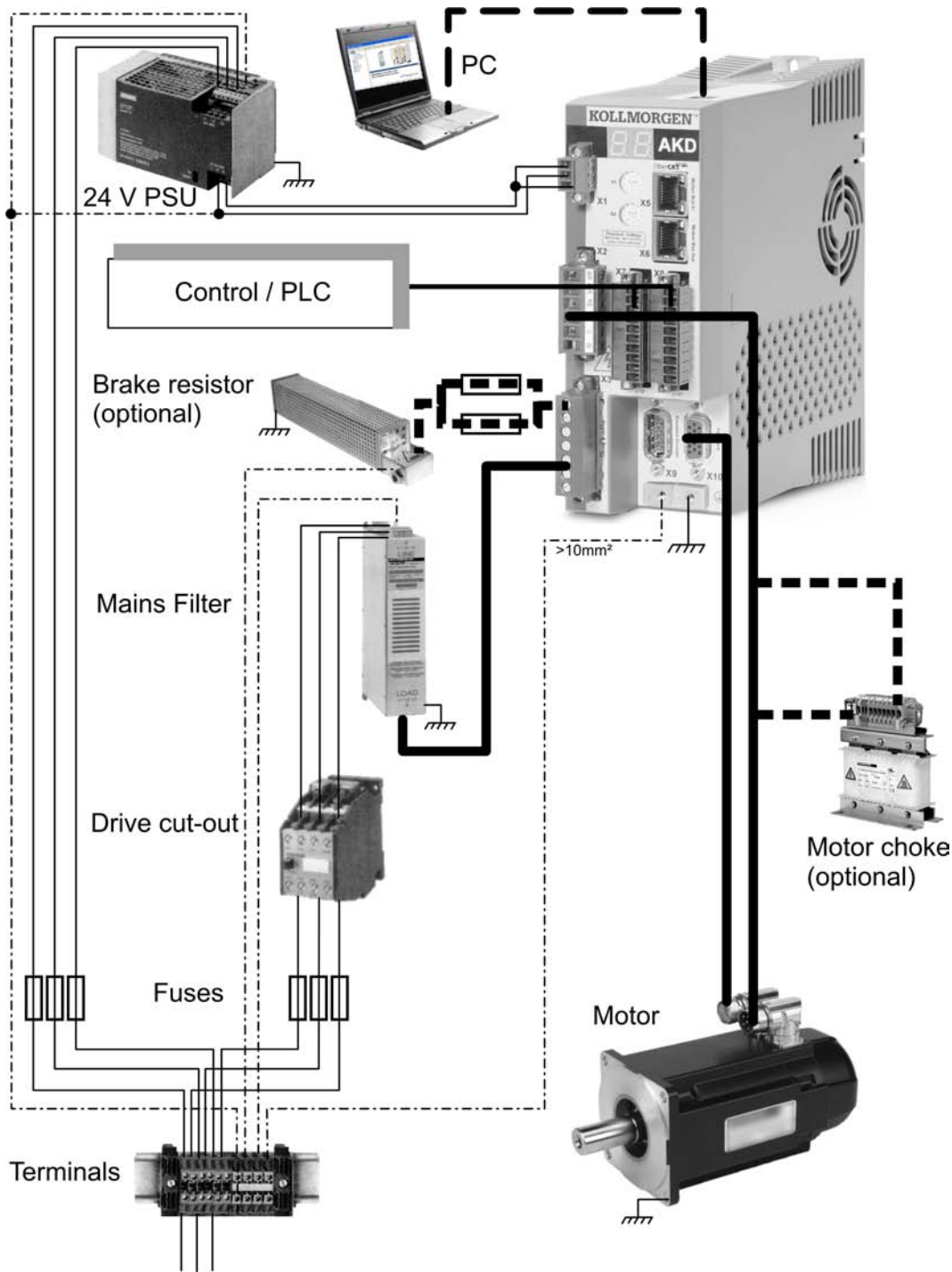

With AKD-xzzz07

NOTE Cables drawn bold are shielded. Electrical ground is drawn with dash-dotted lines. Optional devices are connected with dashed lines to the drive. The required accessories are described in the accessories manual.

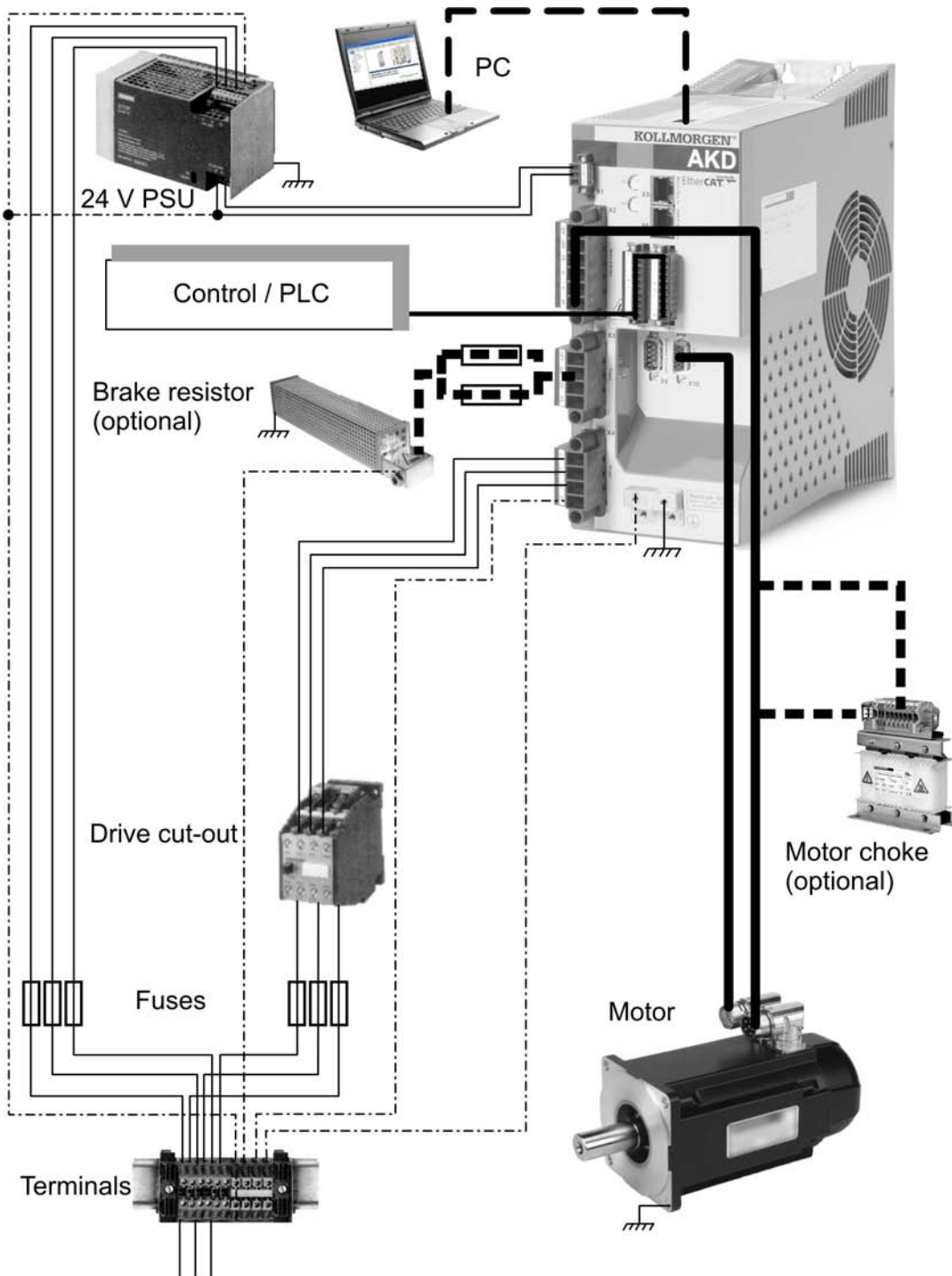

8.5 Connector Assignments, AKD-x00306 to x00606

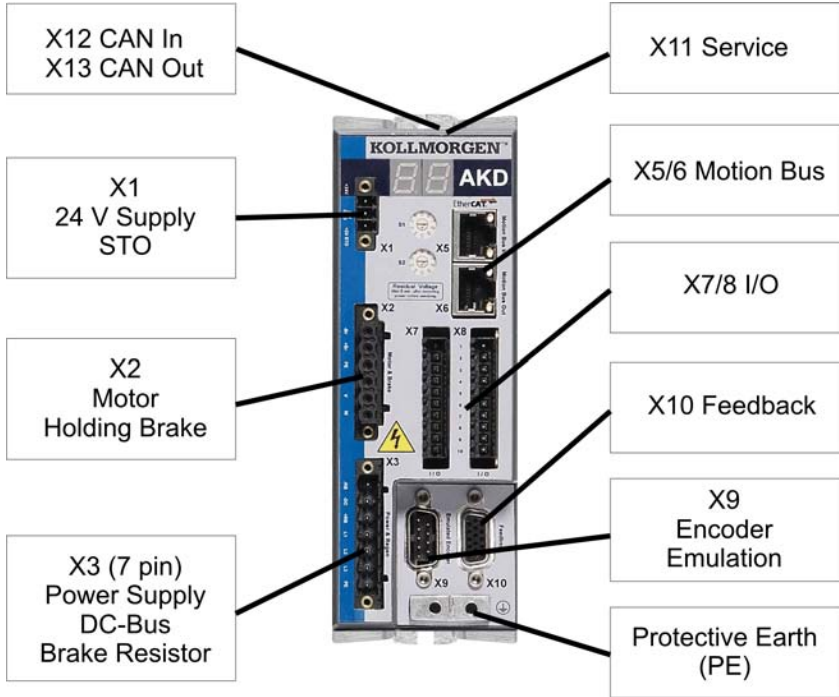

8.6 Connector Assignments, AKD-x01206

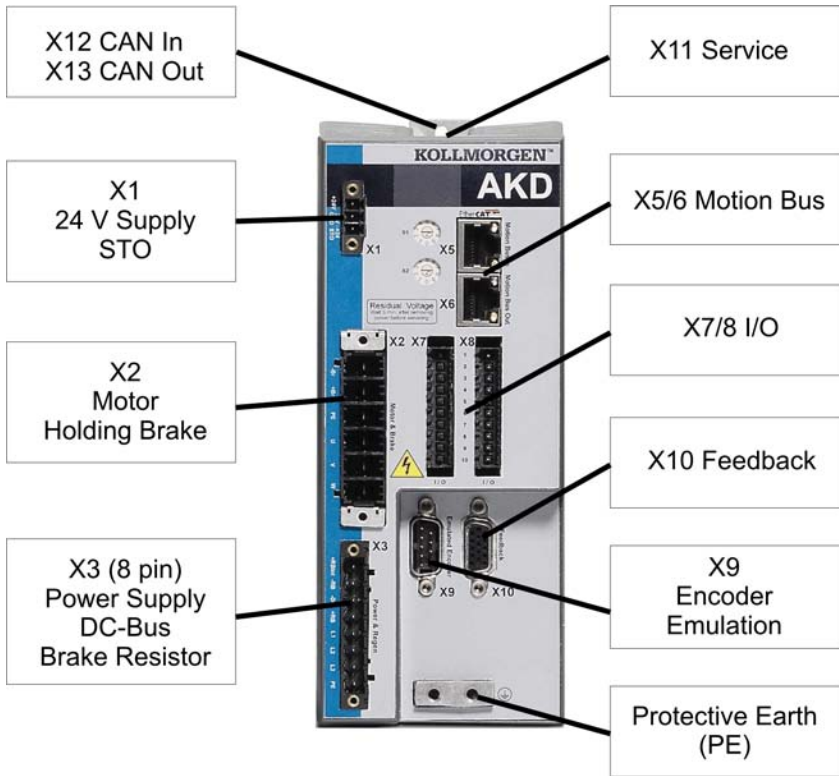

8.7 Connector Assignments, AKD-x02406 and AKD-xzzz07

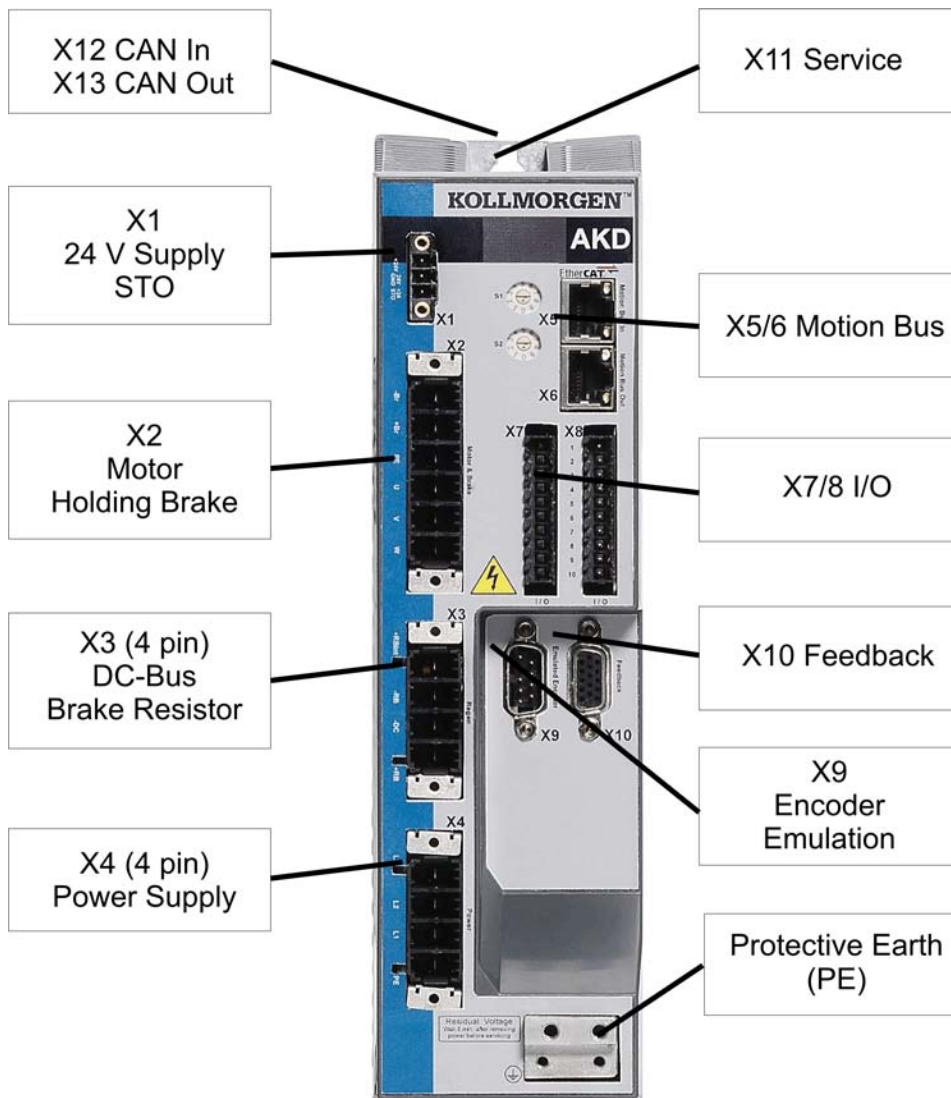

8.8 Connection Diagram, AKD-x00306 to x00606

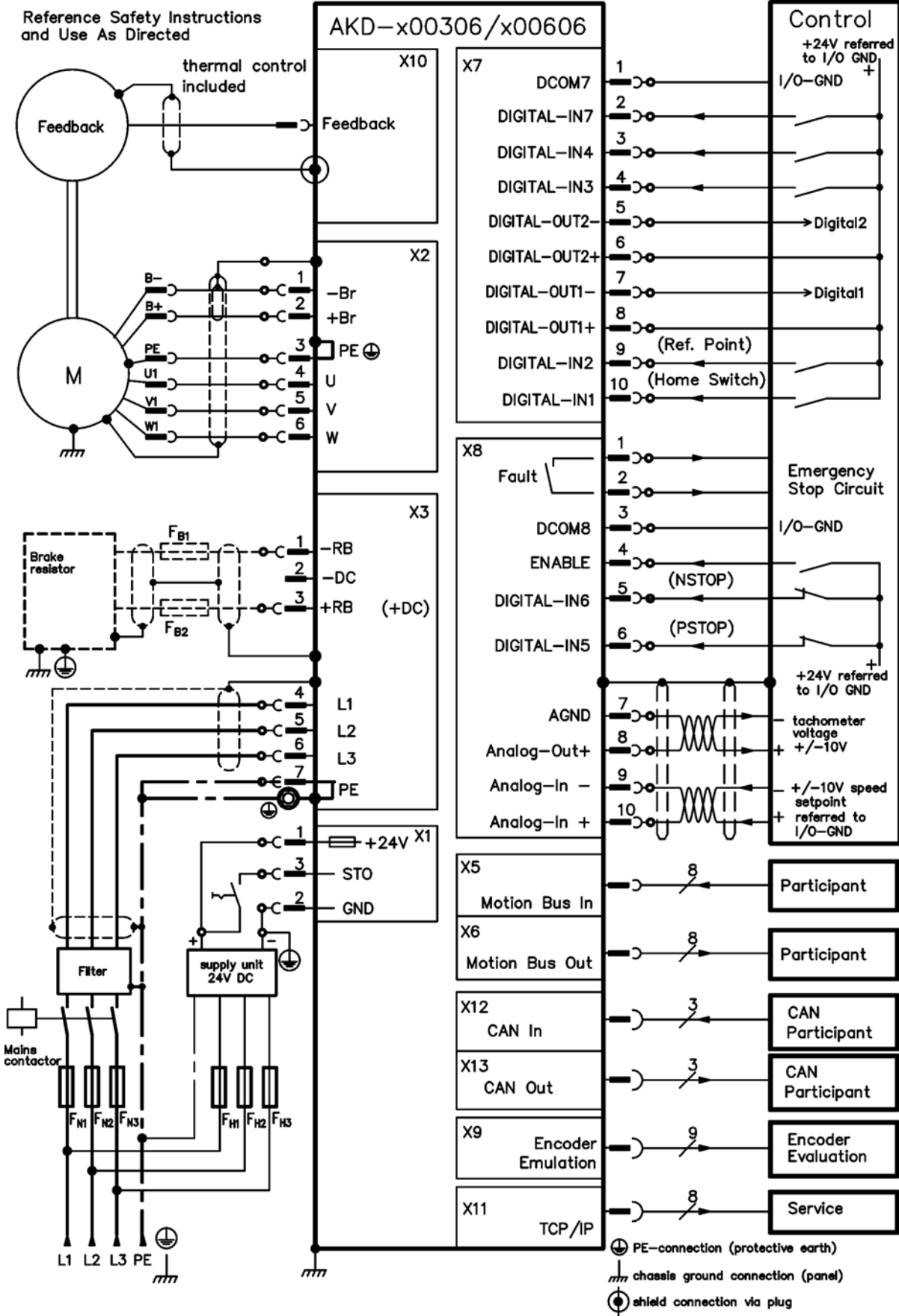

8.9 Connection Diagram, AKD-x01206

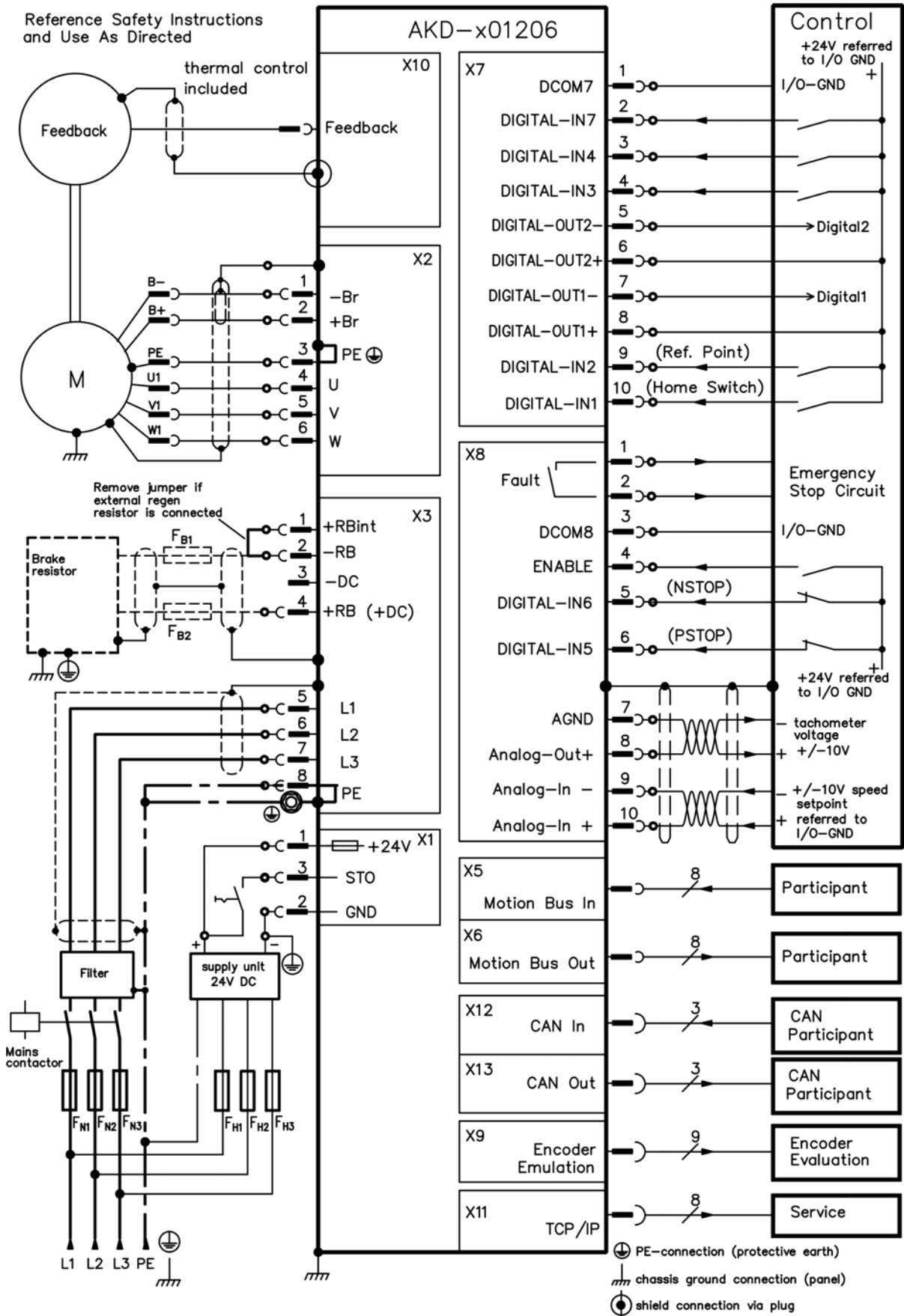

8.10 Connection Diagram, AKD-x02406 and AKD-xzzz07

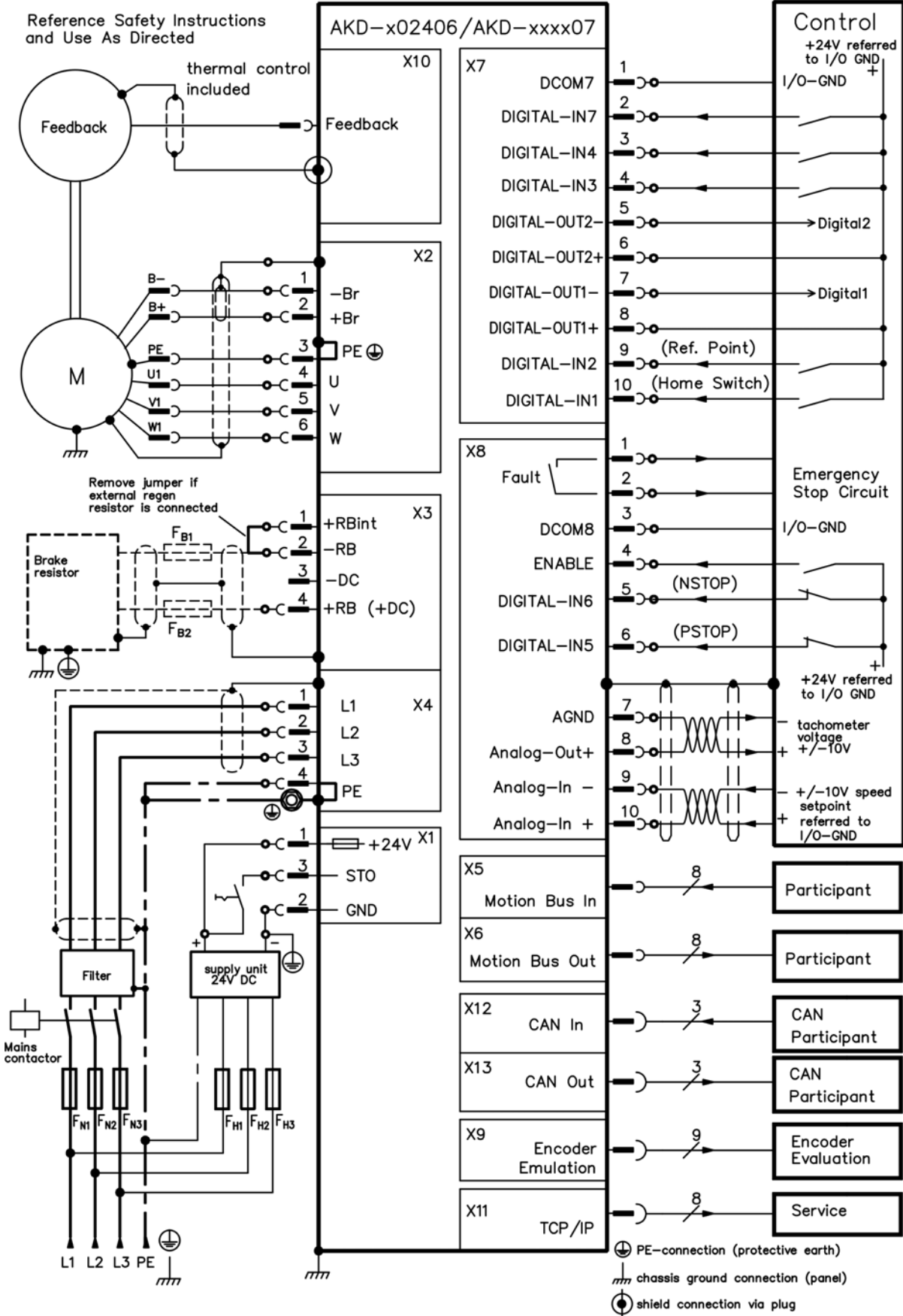

8.11 EMI Noise Reduction

8.11.1 Recommendations for EMI Noise Reduction

The following guidelines will help you to reduce problems with electrical noise in your application.

- Ensure good connections between the cabinet components.
Connect the back panel and cabinet door to the cabinet body using several conductive braids. Never rely on hinges or mounting bolts for ground connections. Provide an electrical connection across the entire back surface of the drive panel. Electrically-conductive panels such as aluminum or galvanized steel are preferred. For painted and other coated metal panels, remove all coating behind the drive.
- Ensure good ground connection.
Connect from cabinet to proper earth ground. Ground leads should be the same gauge as the leads to main power or one gauge smaller.
- Use Kollmorgen™ cables.
Experience has shown that customers who use Kollmorgen™'s power and feedback cables have far fewer problems than customers who build cables.
Route power and control cables separately, Kollmorgen™ recommends a distance of at least 200 mm to improve interference immunity.
If a motor power cable is used that includes cores for brake control, the brake control cores must be separately shielded.
- Ground the shielding at both ends.
Ground all shielding with large areas (low impedance), with metalized connector housings or shield connection clamps wherever possible. For cables entering a cabinet, connect shields on all 360° of the cable. Never connect a simple "pigtail." For more information on shielding concepts, => p. 81.
- With separate mains filter, maintain separation of leads entering and exiting the mains filter (line power filter).
Locate the filter as close as possible to the point where the incoming power enters the cabinet. If it is necessary for input power and motor leads to cross, cross them at 90°.
- Feedback lines may not be extended, since the shielding would be interrupted and the signal processing may be disturbed. Install all feedback cables with an adequate cross-section, per IEC 60204 (=> p. 39) and use the requested cable material to reach maximum cable length.
- Splice cables properly.
If you need to divide cables, use connectors with metal backshells. Ensure that both shells connect along the full 360° of the shields. No portion of the cabling should be unshielded. Never divide a cable across a terminal stripe
- Use differential inputs for analog signals.
Noise susceptibility in analog signals is greatly reduced by using differential inputs. Use twisted-pair, shielded signal lines, connecting shields on both ends.
- Lines between drives and filters and external brake resistor must be shielded.
Install all power cables with an adequate cross-section, as per IEC 60204 (=> p. 39) and use the requested cable material to reach maximum cable length.

8.11.2 Shielding with External Shielding Busbar

EMC filtering must be done externally by the user if necessary, which requires the use of shielded cables. Kollmorgen™ recommends a star point shield connection, for example, with a shielding busbar.

8.11.2.1 Shielding Concept

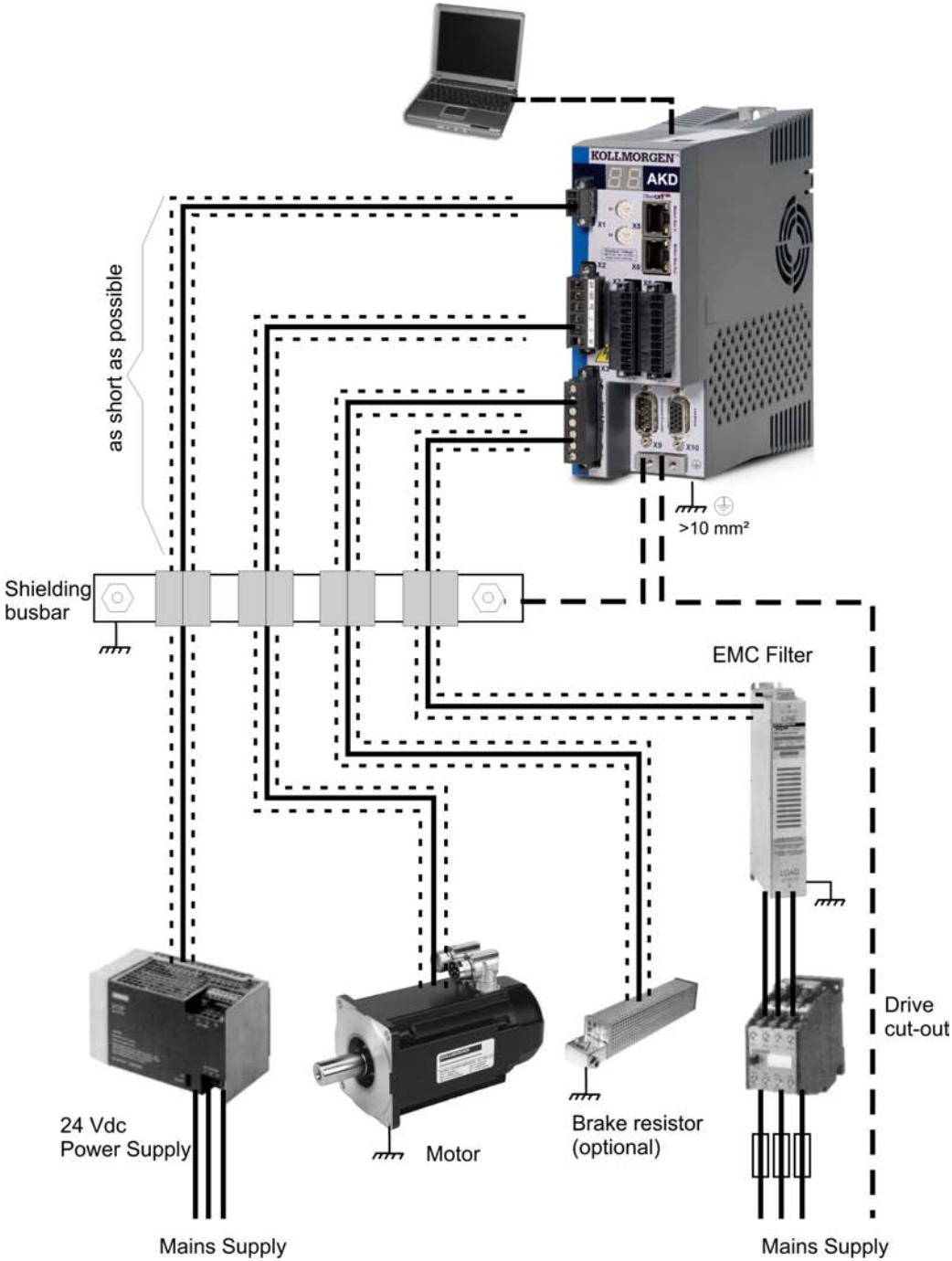

8.11.2.2 Shielding Busbar



The power cable shields (line in, motor cable, external brake resistor) can be routed to an additional busbar via shield clamps.

Kollmorgen™ recommends using Weidmüller KLBÜ shield clamps.

A possible scenario for setting up a busbar for the above shield clamps is described below.

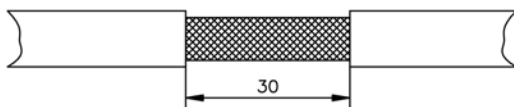
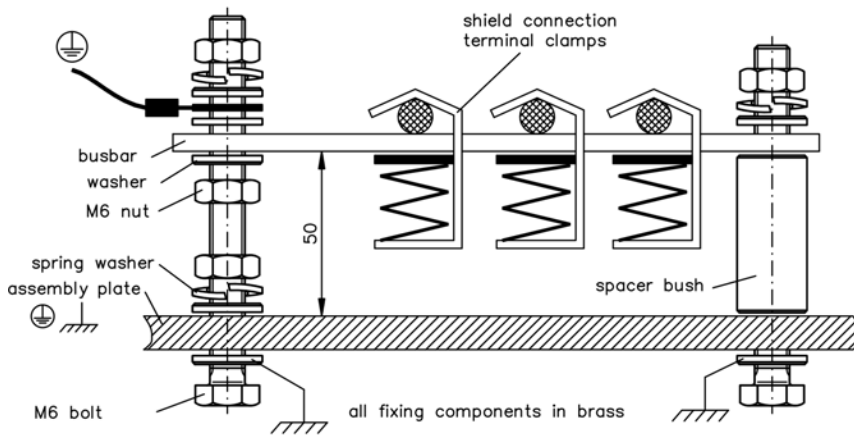
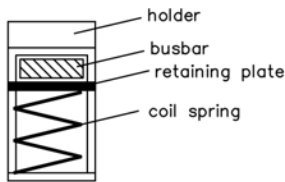
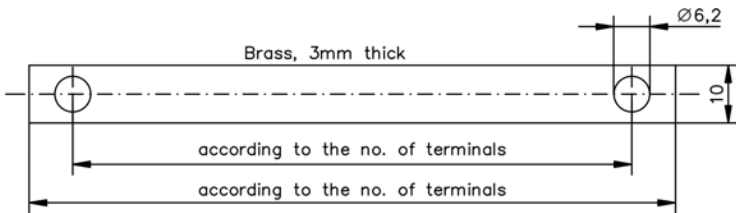

1. Cut a busbar of the required length from a brass rail (cross-section 10 x 3 mm) and drill holes in it as indicated. All shield clamps required must fit between the drill holes.

CAUTION

Risk of injury due to the spring force of the coil spring. Use pliers.

2. Squeeze together the coil spring and the supporting plate and push the busbar through the opening in the holder.
3. Mount the busbar with the shield clamps fitted on the assembly plate. Use either metal spacer bushes or screws with nuts and accessories to maintain a spacing of 50 mm. Earth the busbar using a single conductor with a cross-section of at least 2.5 mm².
4. Strip the external cable sheath to a length of approx. 30 mm, taking care not to damage the braided shield. Push the shield clamp up and route the cable to it via the busbar.

NOTICE

Make sure there is good contact between the shield clamp and the braided shield.

8.11.3 Shielding Connection to the Drive

You can connect cable shielding directly to the drive by using grounding plates, shield connection clamps, and a motor connector with strain relief and grounding plate.

8.11.3.1 Grounding Plates

Mount the grounding plates to the drive as shown in the photos below.

**AKD-x0306 to x1206 types:
L-shape grounding plate**



**AKD-x02406 & zzz07 types:
flat grounding plate**



8.11.3.2 Shield connection clamps



Use shield connection clamps (see accessories manual). These hook into the grounding plate and ensure optimum contact between the shield and the grounding plate.

Kollmorgen™ recommends using Phoenix Contact SK14 shield clamps with clamp range of 6-13mm.

8.11.3.3 Motor Connector X2 with shielding connection

Alternative connection for the motor power connection by mating connector with strain relief.

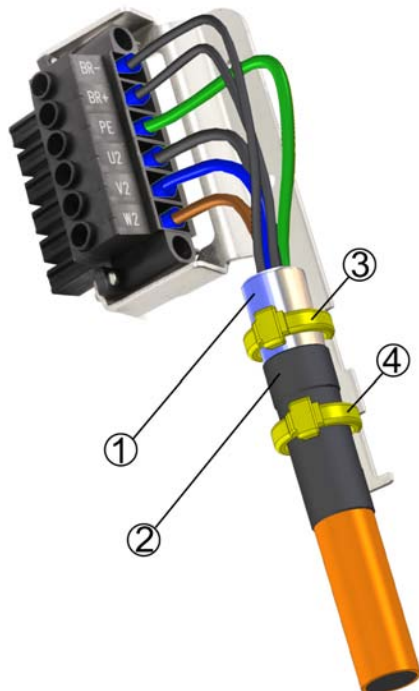

Strip the external cable sheath to a length of approx. 120 mm, taking care not to damage the braided shield. Push the braided shield (1) back over the cable and secure with a rubber sleeve (2) or shrink sleeve.

Shorten all the wires apart from the protective earth (PE) wire (green/yellow) by about 20 mm so that the PE wire is now the longest wire. Strip all wires and fit wire end ferules.

Secure the braided shield of the cable to the shroud with a cable tie (3) and use a second tie (4) to fasten the cable over the rubber sleeve.

Wire the connector as shown in the connection diagram. Plug in the connector to the socket on the front of the AKD.

Screw the connector in place. This ensures that there is conductive contact over a large surface area between the braided shield and the front panel.

8.12 Electrical Supply Connection

8.12.1 Connection to Various Mains Supply Networks AKD-xzzz06 (120V to 240V)

This page illustrates all the possible connection variations for different electrical supply networks.

⚠ WARNING There is a danger of electrical shock with serious personnel injury if the drive is not properly grounded. An isolating transformer is always required for 400 to 480 V networks to get a maximum voltage of 240 V +10%.

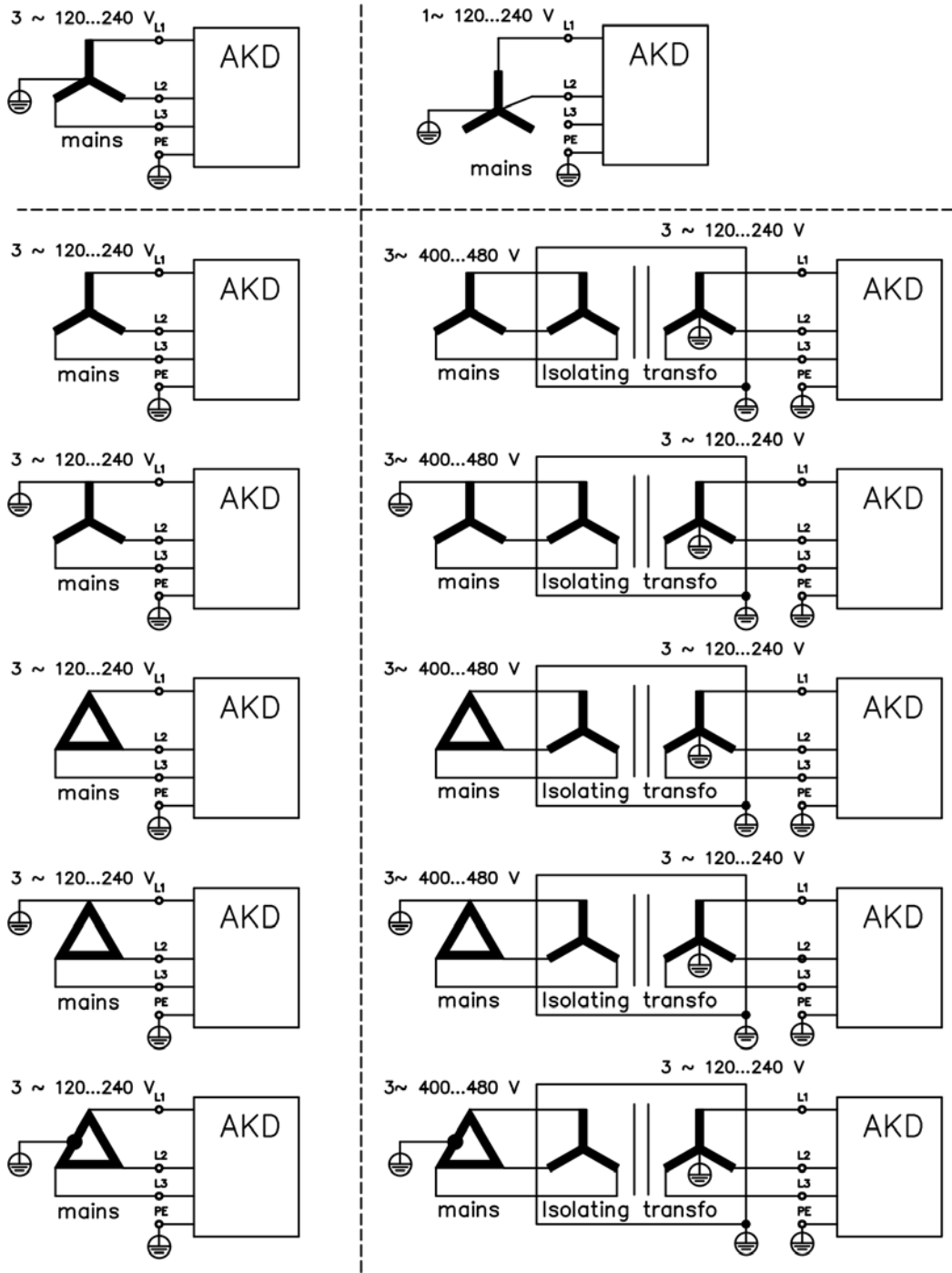

8.12.2 Connection to Various Mains Supply Networks AKD-xzzz07 (240V to 480V)

This page illustrates all the possible connection variations for different electrical supply networks.

⚠ WARNING There is a danger of electrical shock with serious personnel injury if the drive is not properly grounded. An isolating transformer is always required for 120V networks to get a minimum voltage of 240 V +10%.*

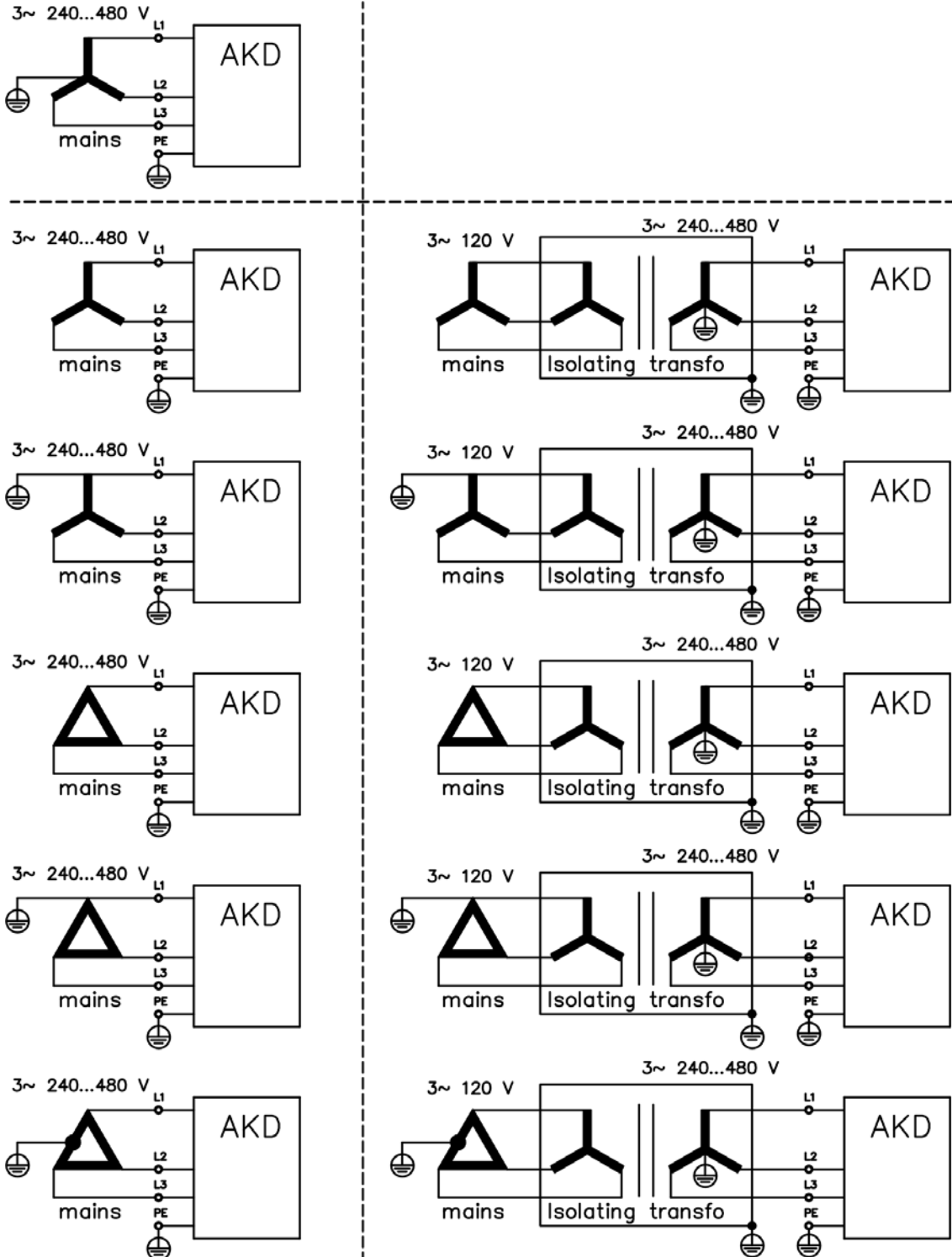

*Presently the AKD-xzzz07 models only support operation at levels above 270 Vac. Updates to the AKD firmware are in process to allow the operation of the AKD-xzzz07 models drives at 240Vac.

8.12.3 24 V Auxiliary Supply (X1)

The following diagram describes external 24 Vdc power supply, electrically isolated, for example, via an isolating transformer. The required current rating depends on the use of motor brake and option card => p. 34 or following).

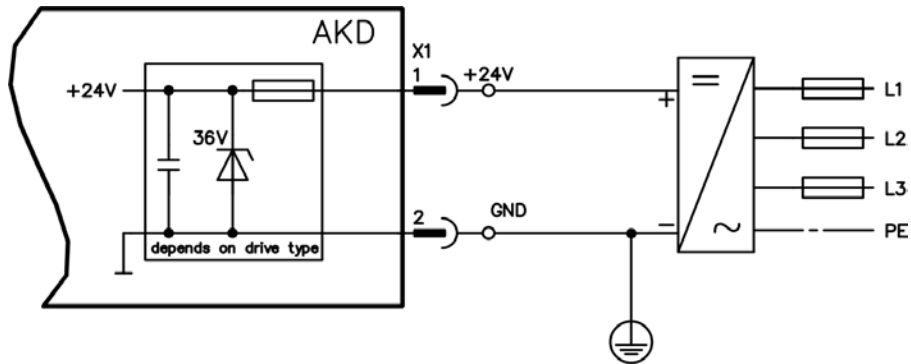

Pin	Signal	Description
1	+24	+24 Vdc Auxiliary voltage
2	GND	24V Supply GND
3	STO	STO enable (Safe Torque Off)

8.12.4 Mains Supply Connection (X3, X4)

8.12.4.1 Three Phase connection (all AKD types)

- Directly to 3-phase supply network, supply networks => p. 84
- Filtering for AKD-xzzz06 to be provided by the user.
- Fusing (such as fusible cut-outs) to be provided by the user => p. 37

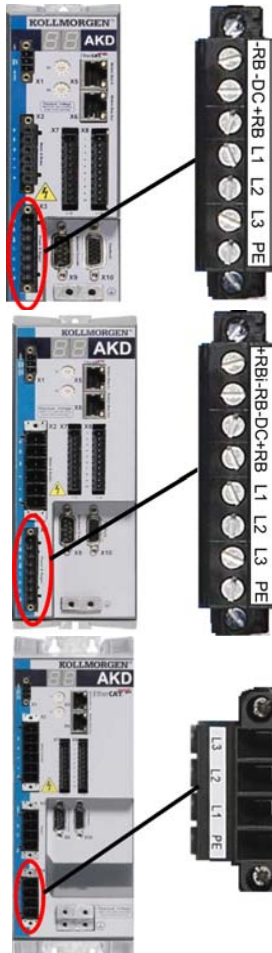
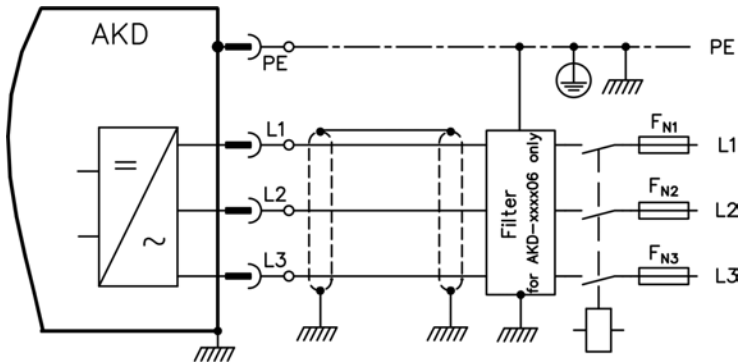

AKD-x00306 to AKD-x00606 (X3)		
Pin	Signal	Description
4	L1	Line 1
5	L2	Line 2
6	L3	Line 3
7	PE	Protective Earth

AKD-x01206 (X3)		
Pin	Signal	Description
5	L1	Line 1
6	L2	Line 2
7	L3	Line 3
8	PE	Protective Earth

AKD-x02406 & AKD-xzzz07 (X4)		
Pin	Signal	Description
1	L1	Line 1
2	L2	Line 2
3	L3	Line 3
4	PE	Protective Earth

8.12.4.2 Single phase connection (AKD-xzzz06 only)

- Directly to single-phase supply network (=> p. 84)
- Supply networks => p. 84
- Leave L3 open circuit
- Filtering to be provided by the user.
- Fusing (such as fusible cut-outs) to be provided by the user => p. 37

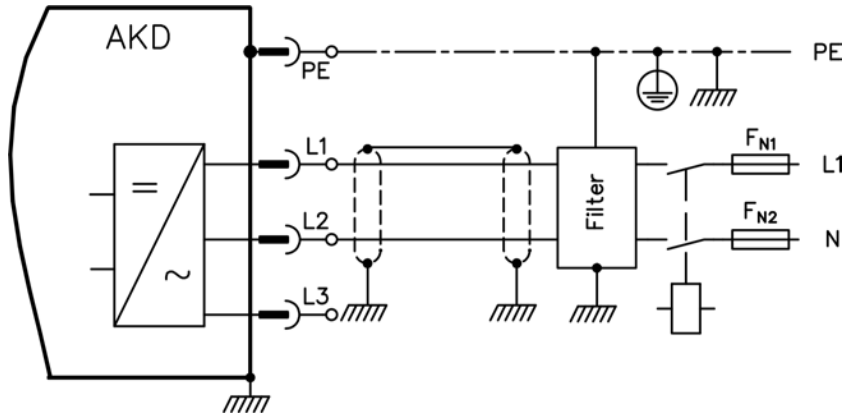

AKD-x00306 to AKD-x00606 (X3)		
Pin	Signal	Description
4	L1	Line 1
5	L2 (N)	Neutral
7	PE	Protective Earth

AKD-x01206 (X3)		
Pin	Signal	Description
5	L1	Line 1
6	L2 (N)	Neutral
8	PE	Protective Earth

8.12.5 External Brake Resistor (X3)

For technical data on the brake circuit "Dynamic Braking" (=> p. 41). Fusing (such as fusible cut-outs) to be provided by the user => p. 37.

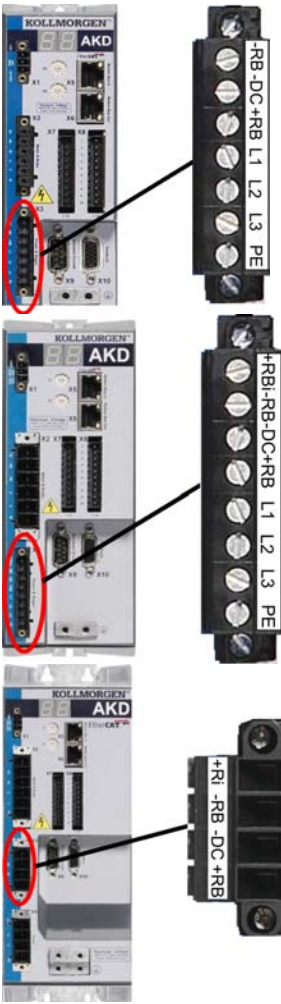
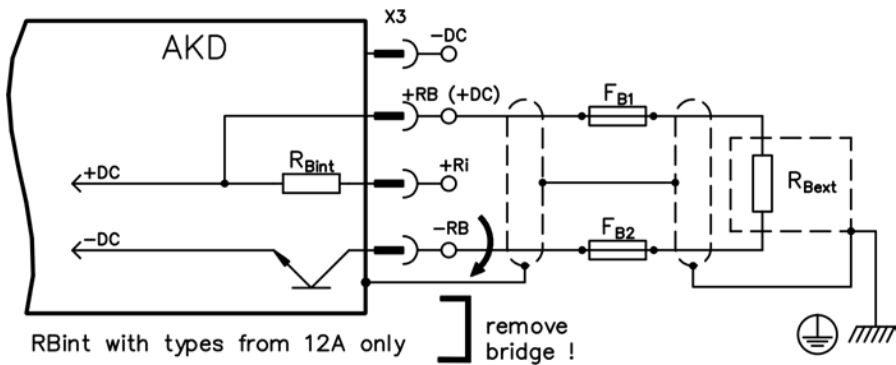

AKD-x00306 to AKD-x00606 (X3)		
Pin	Signal	Description
1	-RB	External Brake Resistor negative
3	+RB	External Brake Resistor positive

AKD-x01206 (X3)		
Pin	Signal	Description
1	+Rbint	Internal Brake Resistor positive
2	-RB	External Brake Resistor negative
4	+RB	External Brake Resistor positive

AKD-x02406 & AKD-xzzz07 (X3)		
Pin	Signal	Description
2	-RB	External Brake Resistor negative
4	+RB	External Brake Resistor positive

8.12.6 DC Bus Link (X3)

The DC bus link can be connected in parallel so that the brake power is divided between all the drives that are connected to the same DC bus link circuit.

Every drive must have it's own power connection to mains voltage, even if the DC bus link is used.

NOTICE The drive can be destroyed if DC bus link voltages are different. Only drives with mains supply from the same mains (identical mains supply voltage) may be connected by the DC bus link. Use unshielded single cores (cross section => p. 39) with a maximum length of 200 mm. Use shielded cables for longer lengths.

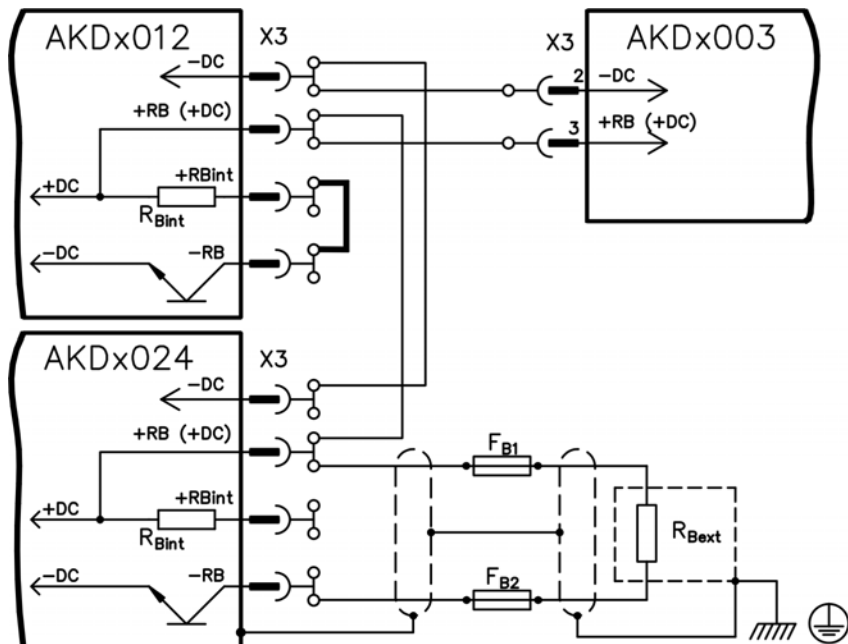

AKD-x00306 to AKD-x00606 (X3)

Pin	Signal	Description
2	-DC	DC-Link Bus negative
3	+DC (+RB)	DC-Link Bus positive

AKD-x01206 (X3)

Pin	Signal	Description
3	-DC	DC-Link Bus negative
4	+DC (+RB)	DC-Link Bus positive

AKD-x02406 & AKD-zzzz07 (X3)

Pin	Signal	Description
3	-DC	DC-Link Bus negative
4	+DC (+RB)	DC-Link Bus positive

8.13 Motor Connection

Together with the motor supply cable and motor winding, the power output of the drive forms an oscillating circuit. Characteristics such as cable capacity, cable length, motor inductance, and frequency ("Electrical Data AKD-xzzz06" (=> p. 34) or "Electrical Data AKD-xzzz07" (=> p. 35)) determine the maximum voltage in the system.

NOTICE	<p>The dynamic voltage rise can lead to a reduction in the motor operating life and, on unsuitable motors, to flashovers in the motor winding.</p> <ul style="list-style-type: none"> ● Only install motors with insulation class F (acc. to IEC60085) or above. ● Only install cables that meet the requirements "Wiring" (=> p. 72).
---------------	---

Connector X2 AKD-xzzz06

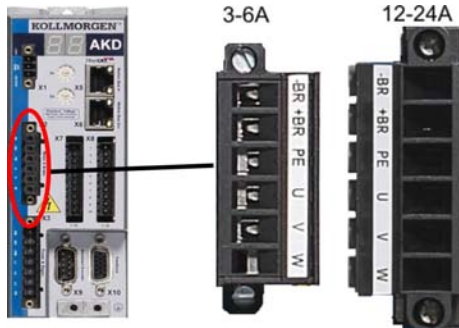

Pin	Signal	Description
1	-BR	Motor holding brake, negative
2	+BR	Motor holding brake, positive
3	PE	Protective earth (motor housing)
4	U	Motor phase U
5	V	Motor phase V
6	W	Motor phase W

Connector X2 AKD-xzzz07

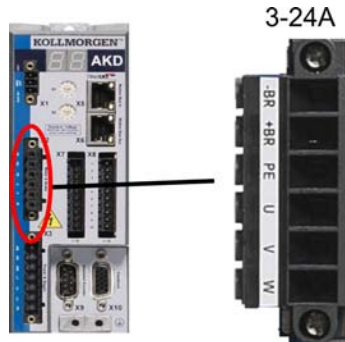

Pin	Signal	Description
1	-BR	Motor holding brake, negative
2	+BR	Motor holding brake, positive
3	PE	Protective earth (motor housing)
4	U	Motor phase U
5	V	Motor phase V
6	W	Motor phase W

8.13.1 Motor Power (X2)

8.13.1.1 Cable Length ≤ 25 m

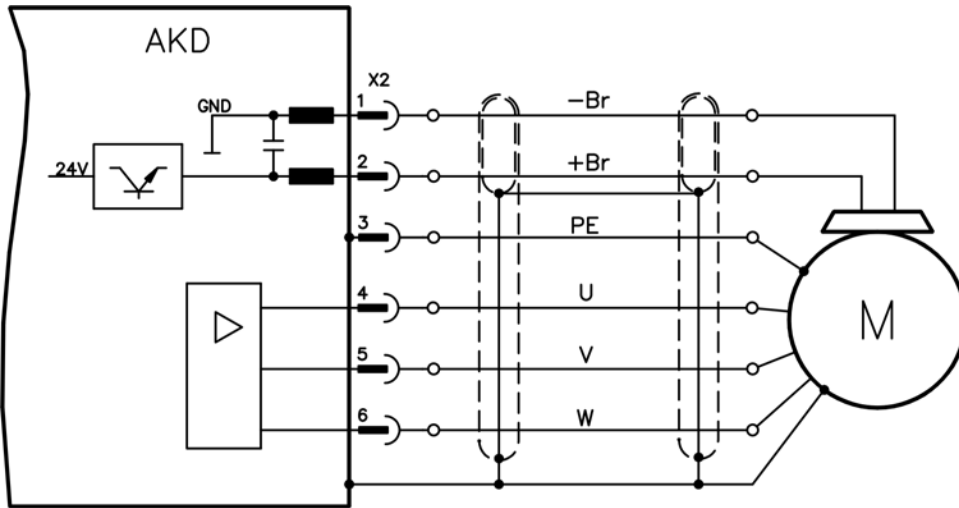

8.13.1.2 Cable length >25 m

NOTICE With long motor cables leakage currents endanger the output stage of the drive. For cable lengths from 25 m to 50 m, a motor choke must be wired into the motor cable (near the drive).

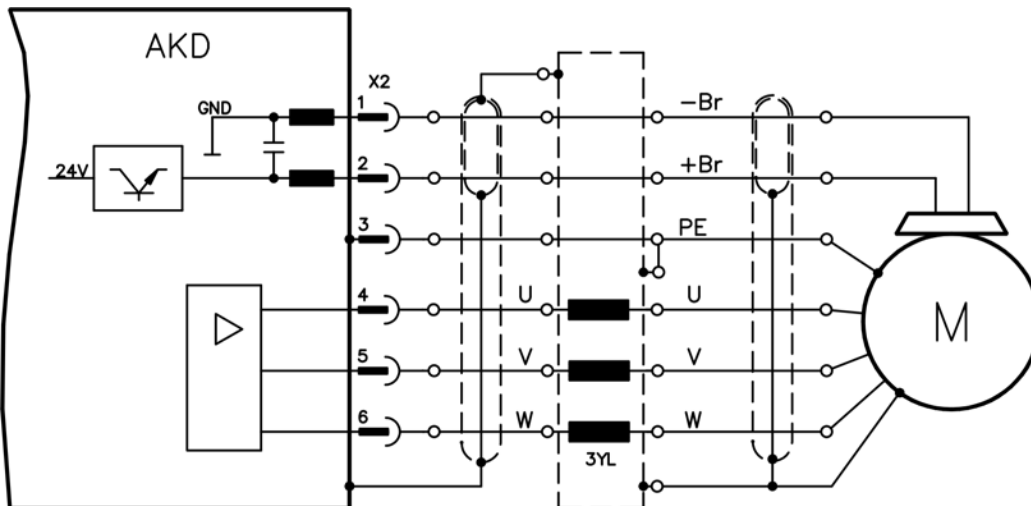

8.13.2 Motor Holding Brake (X2)

A 24 V holding brake in the motor can be controlled directly by the drive.

⚠ CAUTION The brake only works with sufficient 24 V voltage level (=> p. 34 or => p. 35). Check voltage drop, measure the voltage at brake input and check brake function (brake and no brake). This function does not ensure personnel safety.

The Hardware Enable (connector X8 pin4) does not initiate a controlled stop but switches off the power stage immediately.

The brake function must be enabled through a parameter. The diagram below shows the timing and functional relationships between the controlled stop signal, speed setpoint, speed, and braking force. All values can be adjusted with parameters; values in the diagram are default values.

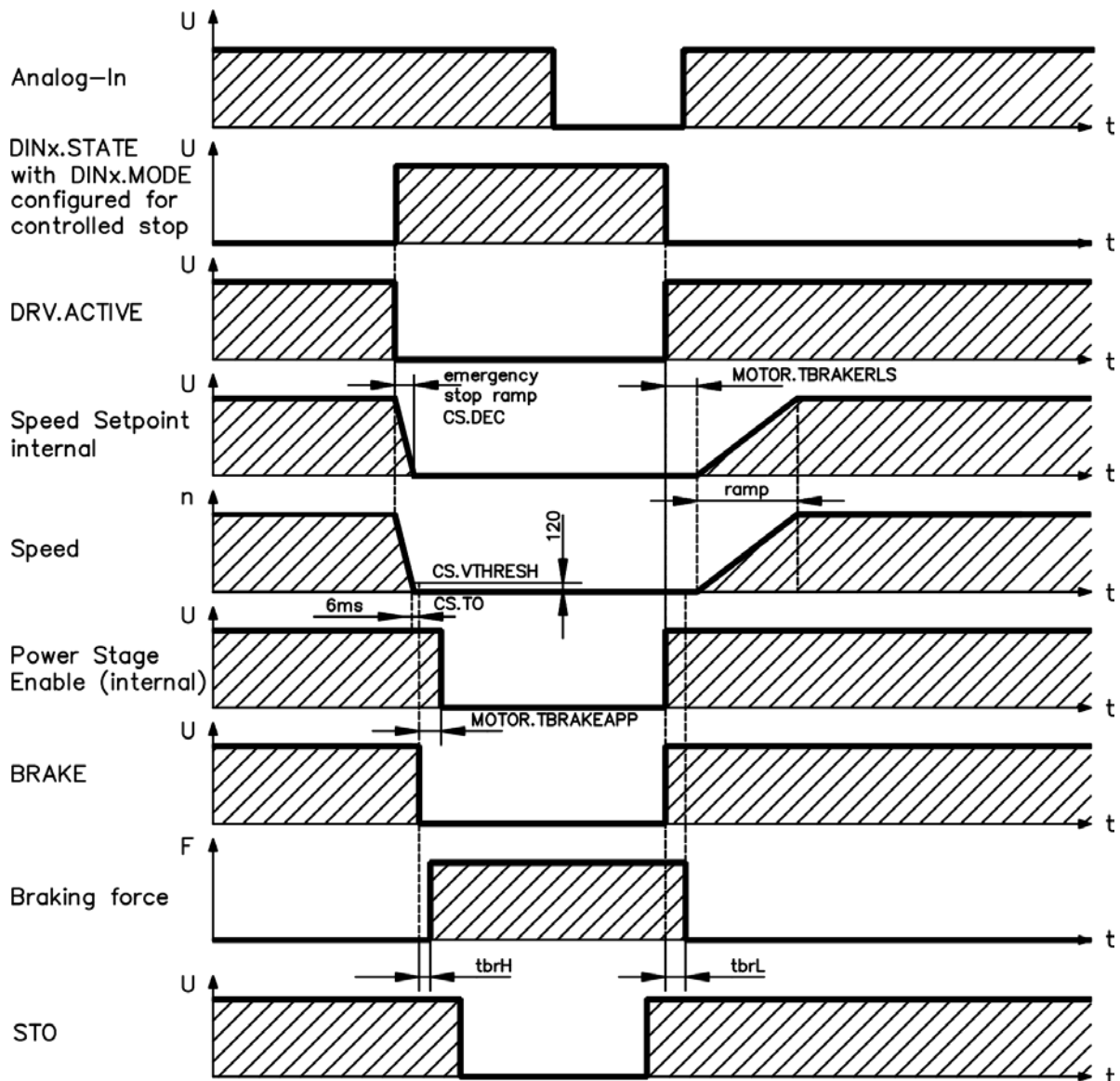

The speed setpoint of the drive is internally driven down an adjustable ramp (CS.DEC) to 0 V. With default values the output for the brake is switched on when the speed has reached 120 rpm (CS.VTHRESH) for at least 6 ms (CS.TO). The rise (t_{brH}) and fall (t_{brL}) times of the holding brake that is built into the motor are different for the various types of motor (see motor manual).

8.14 Feedback Connection

Every closed servo system normally requires at least one feedback device for sending actual values from the motor to the drive. Depending on the type of feedback device used, information will be fed back to the drive using digital or analog means.

AKD supports the most common types of feedback device. Two feedback devices can be used at the same time, and all feedbacks are connected to X10. Feedback functions are assigned with parameters in WorkBench, the setup software. Scaling and other settings are also performed in WorkBench. For a detailed description of the parameters, please refer to the WorkBench online help.

The table below provides an overview of the supported feedback types, their corresponding parameters, and a reference to the relevant connection diagram in each case.

Feedback Types	Wiring	Connector	FBTYPE
Resolver	=> p. 96	X10	40
SFD	=> p. 97	X10	41
SinCos Encoder BiSS	=> p. 98	X10	32
SinCos Encoder ENDAT 2.1	=> p. 99	X10	30
SinCos Encoder ENDAT 2.2	=> p. 100	X10	31
SinCos Encoder Hiperface	=> p. 101	X10	33
Sine Encoder + Hall	=> p. 102	X10	20
Sine Encoder (Wake&Shake)	=> p. 102	X10	21
Incremental Encoder + Hall	=> p. 103	X10	10
Incremental Encoder (Wake&Shake)	=> p. 103	X10	11

8.14.1 Feedback Connector (X10)

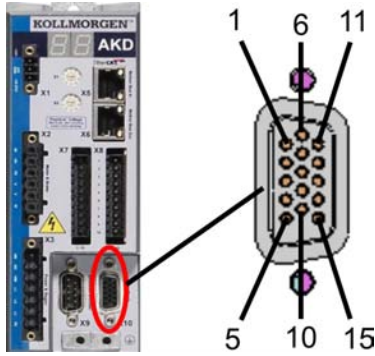

Pin	SFD	Resolver	BiSS (analog)	EnDAT 2.1	EnDAT 2.2	Hiper-face	Sine Encoder +Hall	Incremental Encoder +Hall
1	-	-	-	-	-	-	Hall U	Hall U
2	-	-	CLOCK+	CLOCK+	CLOCK+	-	Hall V	Hall V
3	-	-	CLOCK-	CLOCK-	CLOCK-	-	Hall W	Hall W
4	SENSE+	-	SENSE+	SENSE+	SENSE+	SENSE+	SENSE+	SENSE+
5	SENSE-	-	SENSE-	SENSE-	SENSE-	SENSE-	SENSE-	SENSE-
6	COM+	R1 Ref+	DATA+	DATA+	DATA+	DATA+	Zero+	Zero+
7	COM-	R2 Ref-	DATA-	DATA-	DATA-	DATA-	Zero-	Zero-
8	-	Thermal control (PTC)						
9	-	Thermal control (PTC, GND)						
10	+5 V	-	+5 V	+5 V	+5 V	+8 to +9 V	+5 V	+5 V
11	0 V	-	0 V	0 V	0 V	0 V	0 V	0 V
12	-	S1 SIN+	A+	A+	-	SIN+	A+	A+
13	-	S3 SIN-	A-	A-	-	SIN-	A-	A-
14	-	S2 COS+	B+	B+	-	COS+	B+	B+
15	-	S4 COS-	B-	B-	-	COS-	B-	B-

8.14.2 Resolver

The diagram below shows the connection of a resolver (2 to 36-poles) as a feedback system. The thermal control in the motor is connected via the resolver cable and evaluated in the drive.

If cable lengths of more than 100 m are planned, please contact customer support.

Type	FATYPE	Description
Resolver	40	Accuracy: 14 bit (0.022°), resolution: 16 bit (0.006°)

The pin assignment shown on the resolver side relates to Kollmorgen™ motors.

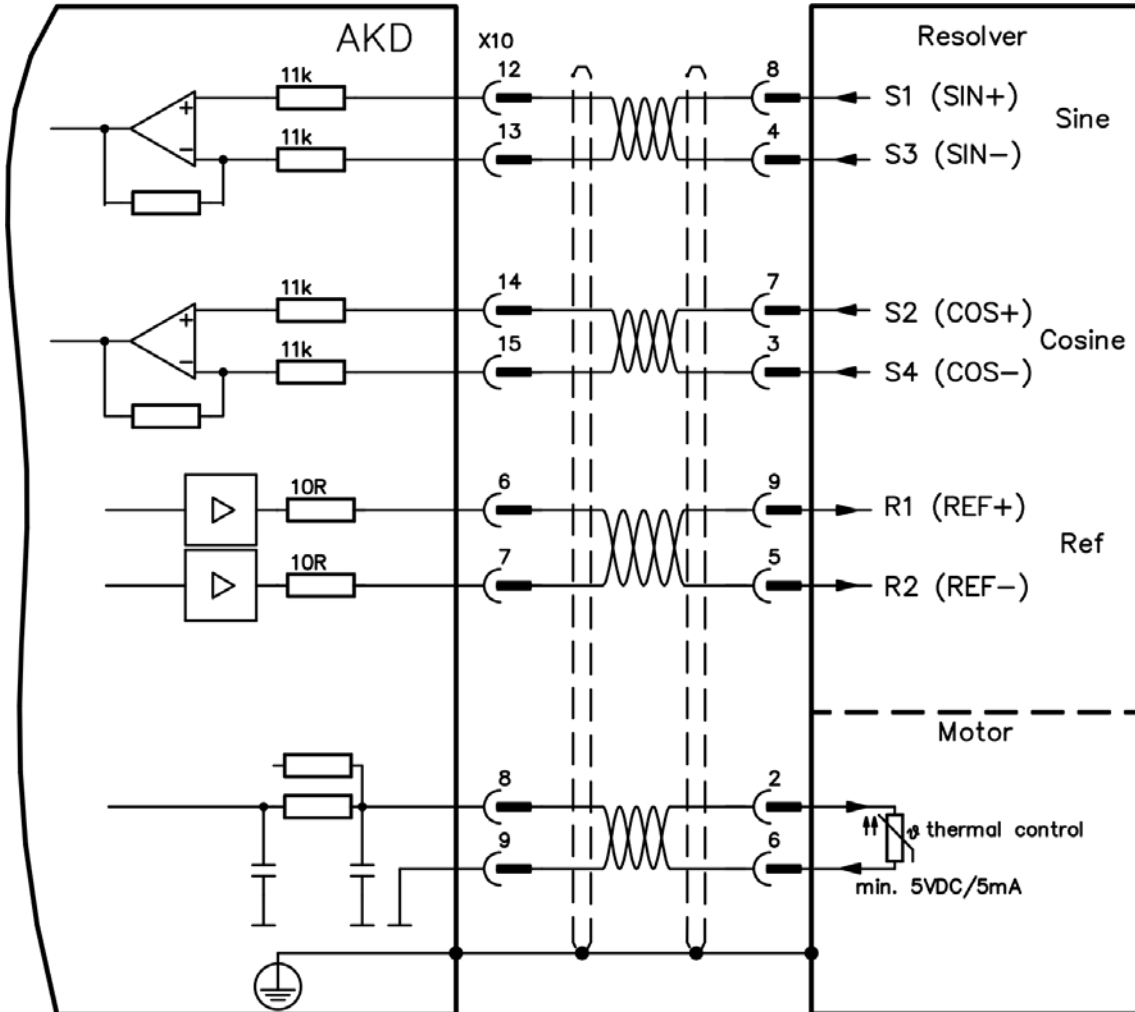

8.14.3 SFD

The diagram below shows the connection of the Kollmorgen™ feedback system.

The "Sense" input is required only for cables longer than 50 m or if the wire resistance from drive to sensor exceeds 3.3 ohm.

Type	FBTYPE	Up	Remarks
Smart Feedback Device	41	5 V +/-5%	accuracy 14 bit (0.022°), resolution 24 bit (2 x 10E-5°)

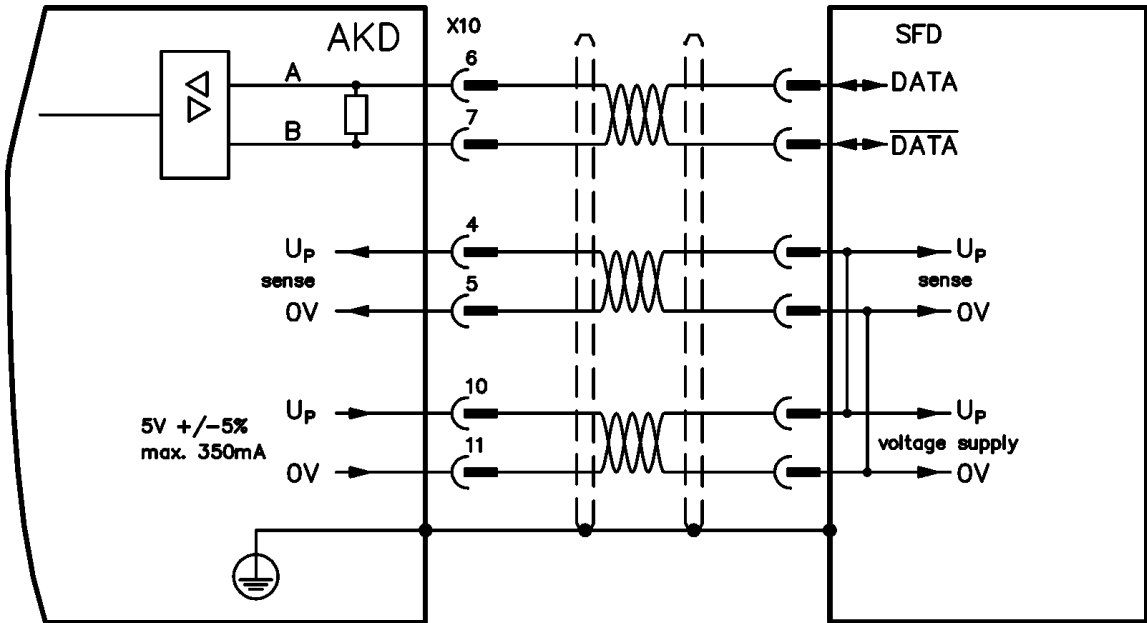

8.14.4 Encoder with BiSS

The diagram below shows the wiring of a single-turn or multi-turn sine-cosine encoder with BiSS interface as a feedback system. The thermal control in the motor is connected via the encoder cable and evaluated in the drive.

If cable lengths of more than 50 m are planned, please consult customer support.

Type	FATYPE	Up	Frequency Limit
5 V analog	32	5 V +/-5%	1 MHz

The pin assignment shown on the encoder side relates to Kollmorgen™ motors.

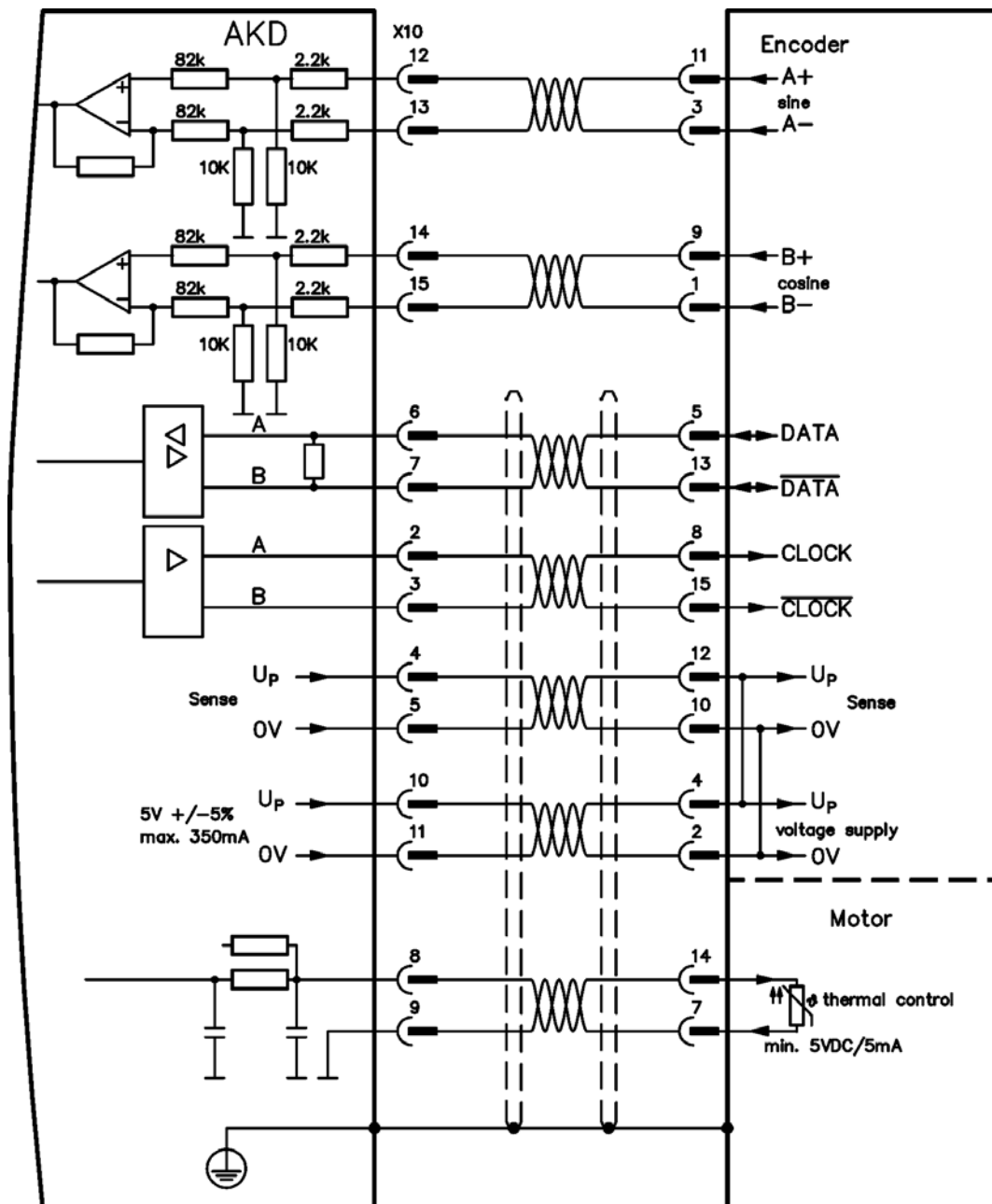

8.14.5 Sine Encoder with EnDat 2.1

The diagram below shows the wiring of a single-turn or multi-turn sine-cosine encoder with EnDat 2.1 interface as a feedback system. Preferred types are the ECN1313 and EQN1325 encoders. The thermal control in the motor is connected via the encoder cable and evaluated in the drive. All signals are connected using our pre-assembled encoder connection cable. If cable lengths of more than 50 m are planned, consult customer support.

Type	FBSYMBOL	Frequency Limit
ENDAT 2.1	30	1 MHz

The pin assignment shown on the encoder side relates to Kollmorgen™ motors.

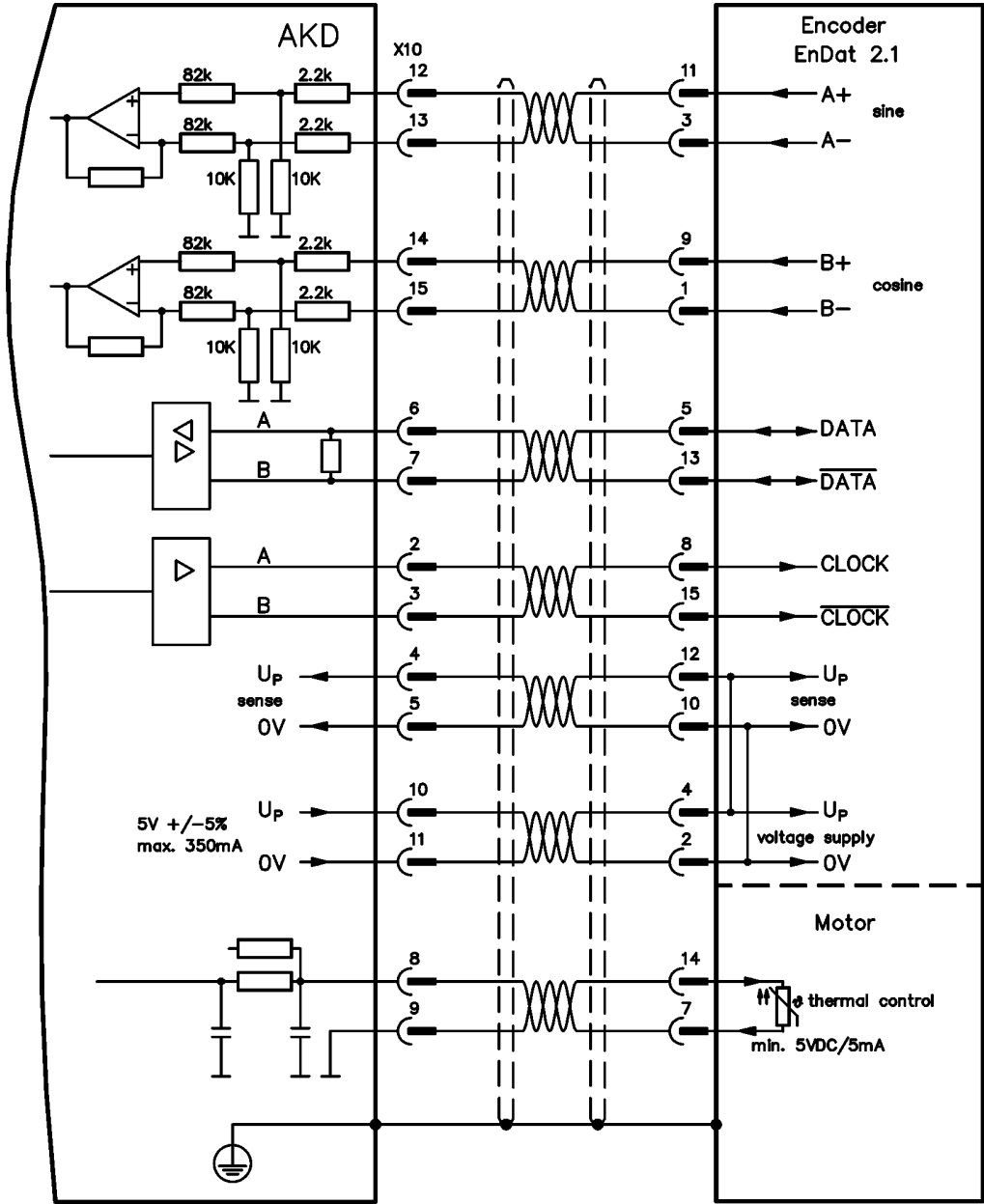

8.14.6 Encoder with EnDat 2.2

The table and figure below describe wiring of a single-turn or multi-turn encoder with EnDat 2.2 interface as a feedback system. Preferred types are the ECN1313 and EQN1325 encoders.

The thermal control in the motor is connected via the encoder cable and evaluated in the drive. All signals are connected using our pre-assembled encoder connection cable.

If cable lengths of more than 50 m are planned, please consult customer support.

Type	FBTYP	Frequency Limit	Description
ENDAT 2.2	31	1 MHz	Adjust on screen page FEEDBACK

The pin assignment shown on the encoder side relates to Kollmorgen™ motors.

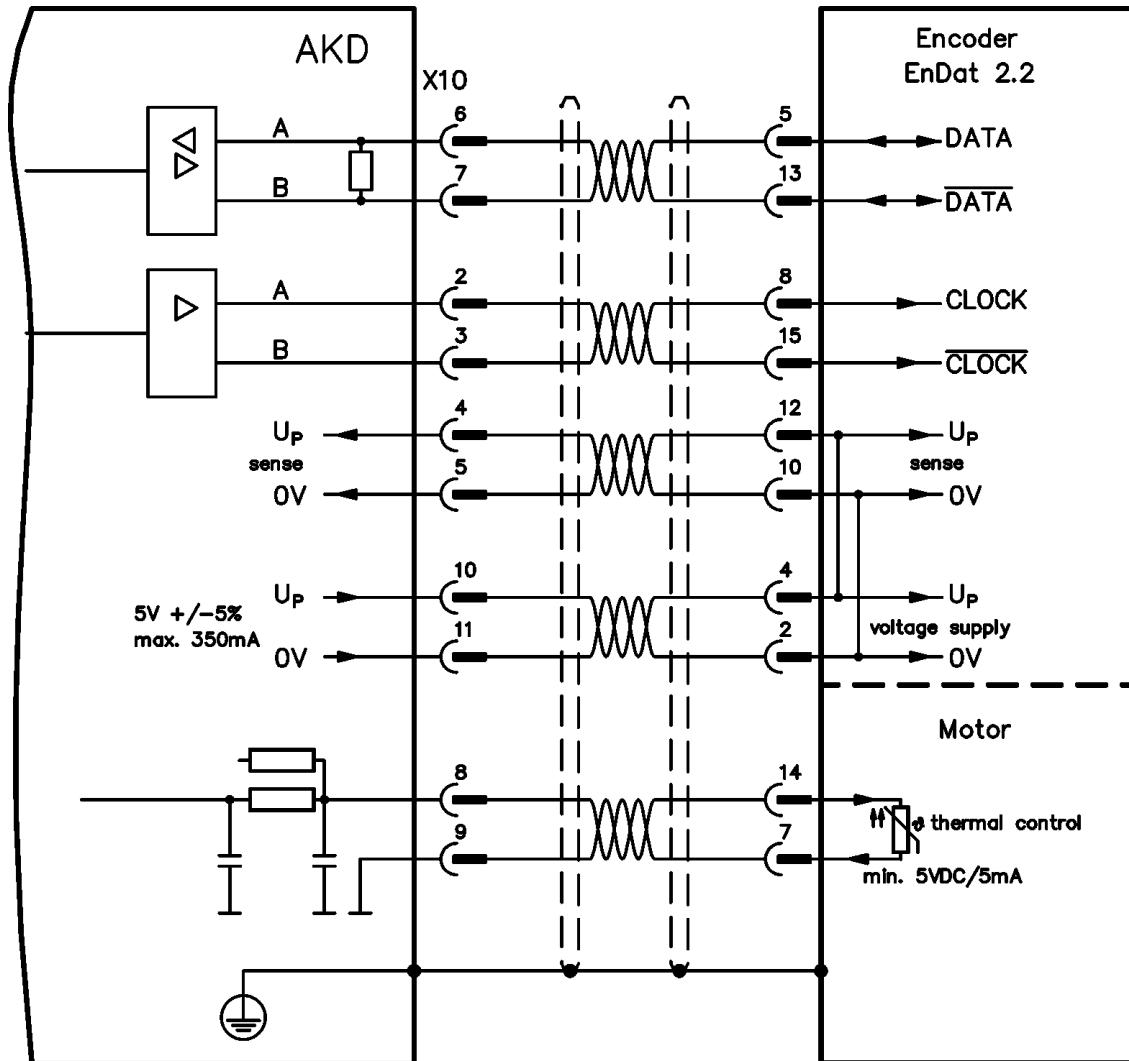

8.14.7 Sine Encoder with Hiperface

The diagram below shows the wiring of a single-turn or multi-turn sine-cosine encoder with Hiperface interface as a feedback system.

The thermal control in the motor is connected via the encoder cable and evaluated in the drive. All signals are connected using our pre-assembled encoder connection cable.

If cable lengths of more than 50 m are planned, please consult customer support.

Type	FBTYPE	Frequency Limit	Description
Hiperface	33	1 MHz	Connecting pin 4 and 5 together causes Up to be 8 to 9 V

The pin assignment shown on the encoder side relates to Kollmorgen™ motors.

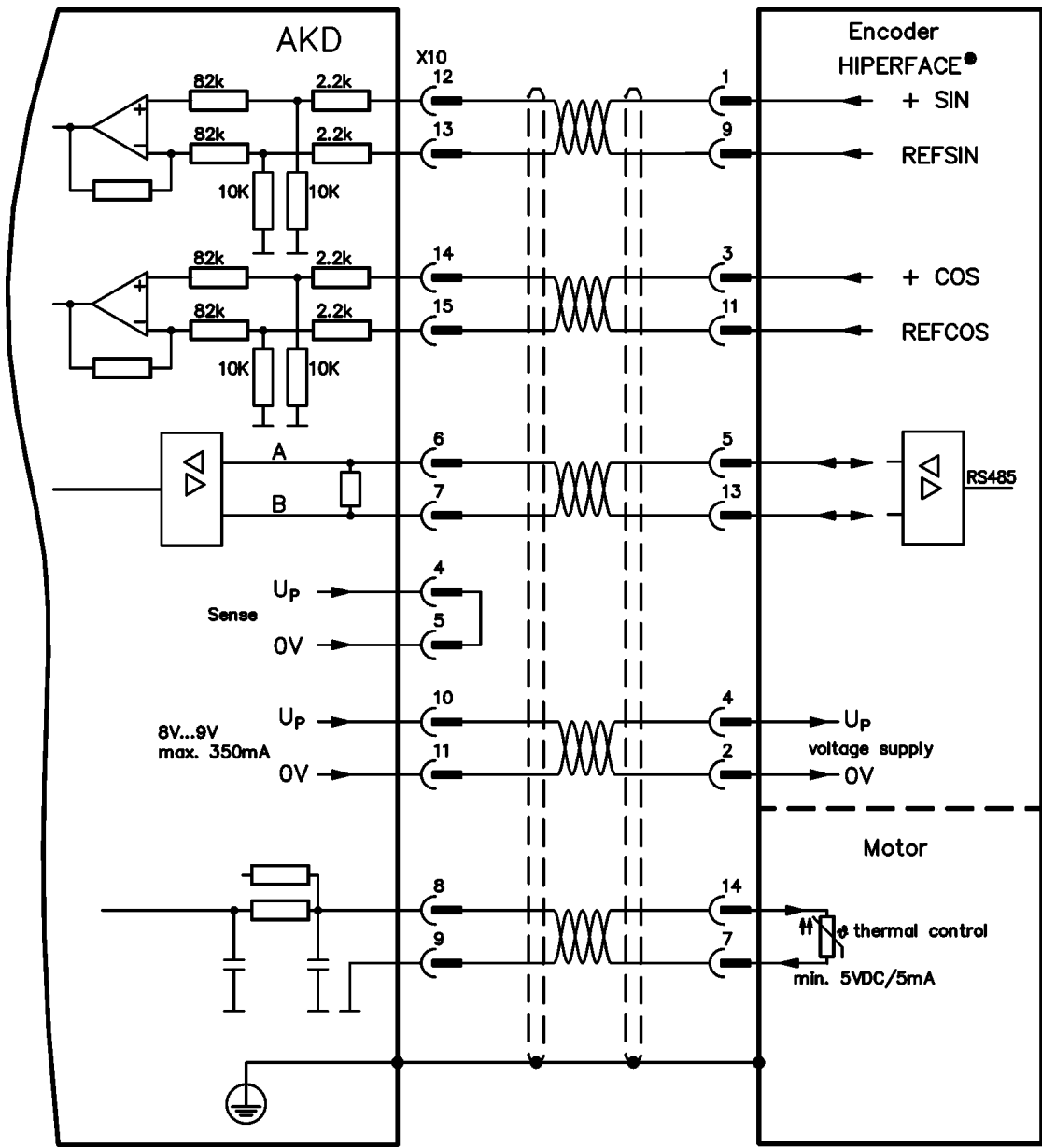

8.14.8 Sine Encoder

Feedback devices, which do not deliver absolute information for commutation, can either work with wake&shake commutation (see *AKD User Guide*) or can be used as a complete feedback system when combined with an additional Hall encoder. All signals are connected to X10 and evaluated there. If cable lengths of more than 25 m are planned, please consult customer support. The "Sense" signal is optional, and can be omitted if the encoder cable is short and no significant voltage drop is on the cable. The voltage drop depends on the cable length and gage and the encoder current consumption.

Type	FBTYP	Up	Frequency Limit (sin, cos)
SinCos 5 V with Hall	20	5 V +/-5%	1 MHz
SinCos 5 V (Wake&Shake)	21	5 V +/-5%	1 MHz

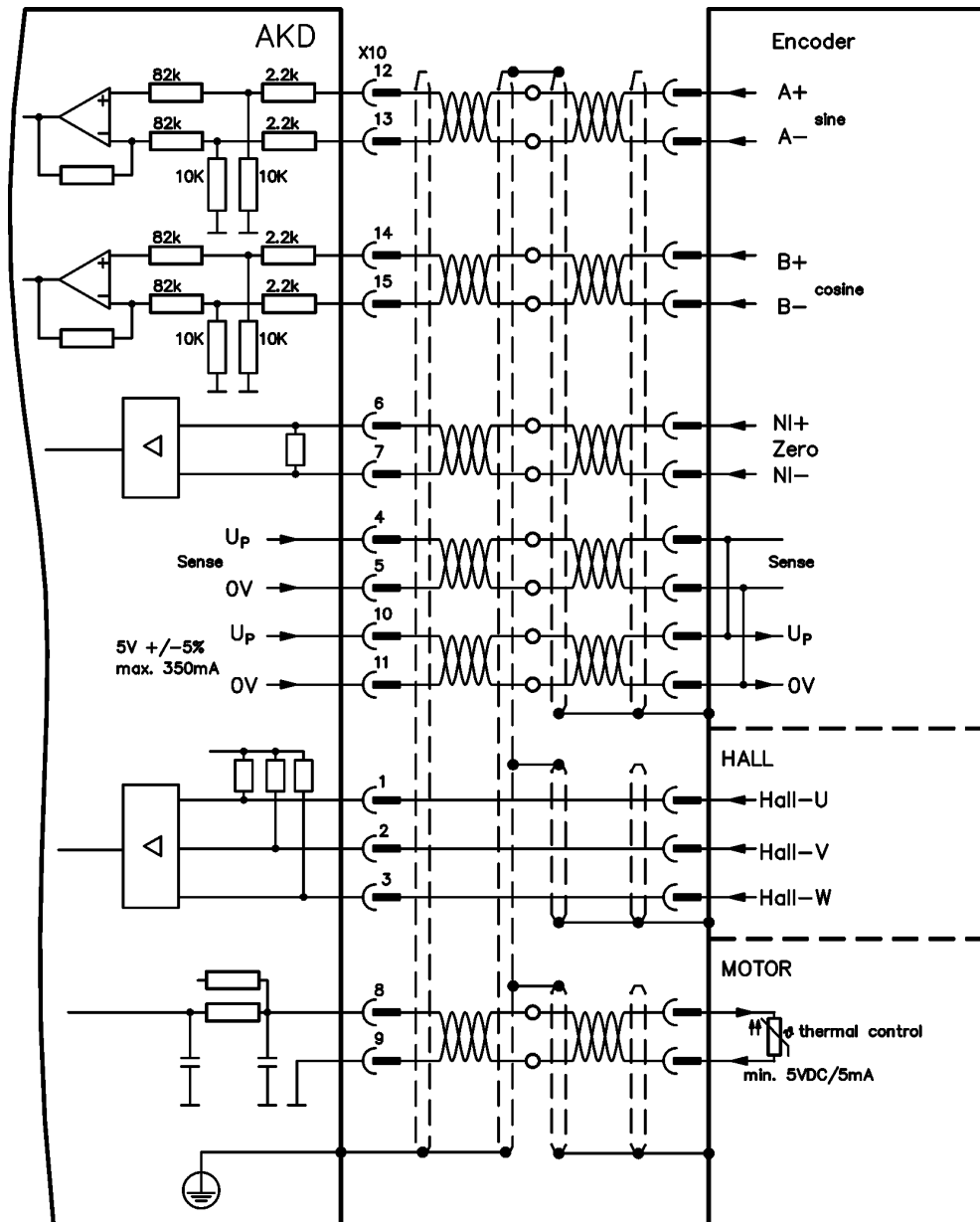

8.14.9 Incremental Encoder

Feedback devices, which do not deliver absolute information for commutation, can either work with wake&shake commutation (see *AKD User Guide*) or can be used as a complete feedback system when combined with an additional Hall encoder. All signals are connected using a pre-assembled comcoder connection cable. If cable lengths of more than 25 m are planned, please consult customer support. The "Sense" signal is optional, and can be omitted if the encoder cable is short and no significant voltage drop is on the cable. The voltage drop depends on the cable length and gage and the encoder current consumption.

Type	FBTYPE	Frequency Limit
Incremental Encoder&Hall Switches (Comcoder)	10	2.5 MHz
Incremental Encoder (Wake&Shake)	11	2.5 MHz

The pin assignment shown on the encoder side relates to Kollmorgen™ motors.

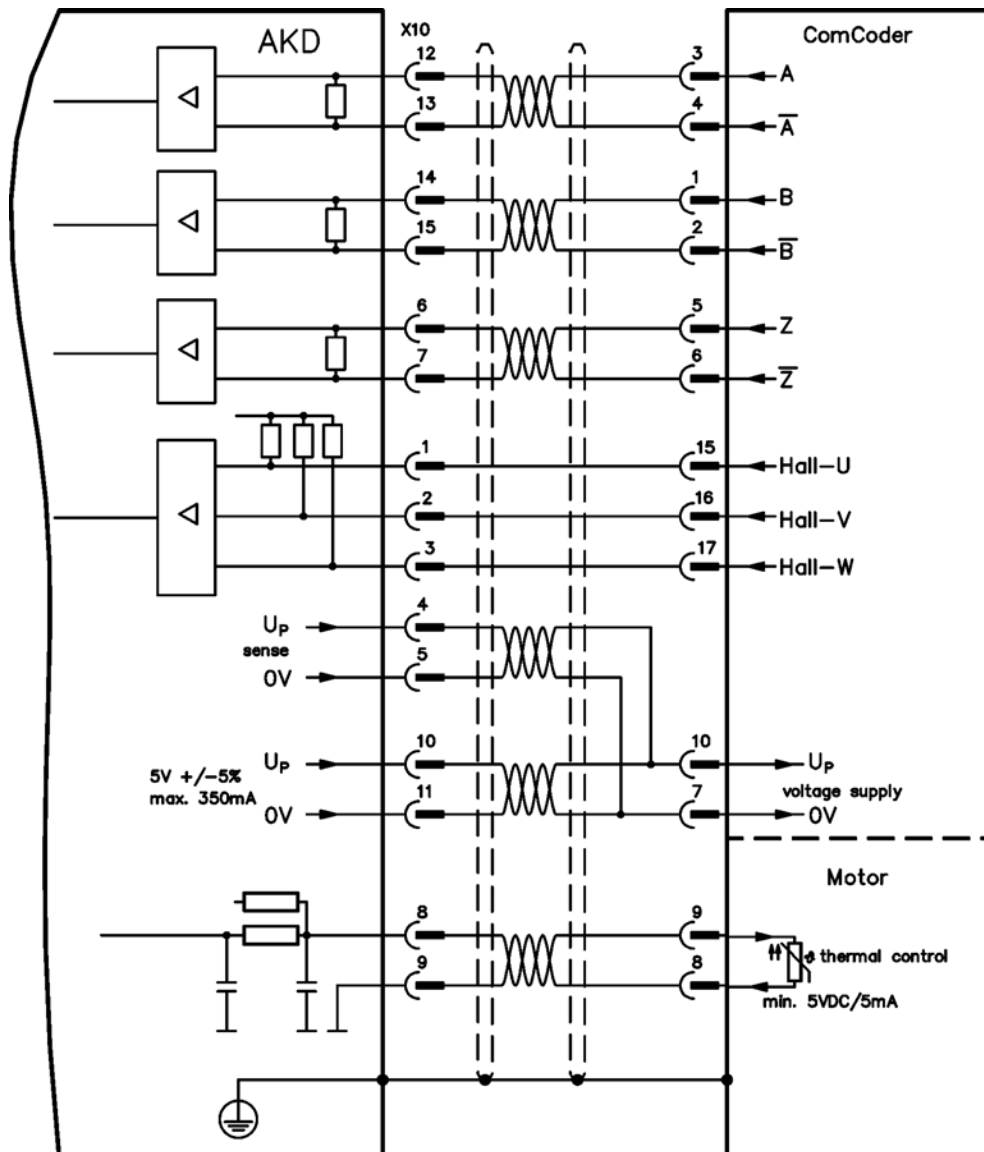

8.15 Electronic gearing, Master-slave operation

It is possible to set up master/slave systems, use an external encoder as a command encoder, secondary feedback device (dual loop control) or connect the amplifier to a third party step controller. Depending on the signal voltage level connector X9 (5 V TTL) or X7 (24 V) must be used.

The WorkBench setup software is used for configuration. See the "Feedback 2" screen in WorkBench for setup. FB2.SOURCE, FB2.MODE, FB2.ENCRES and others are used for setting up an application with these interfaces.

Connector X9 can be configured as an input or as an output for 5 V (TTL level) signals.

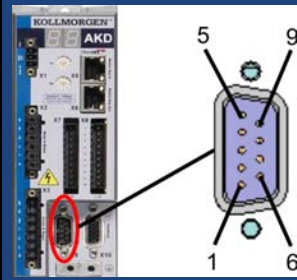
	Input modes X9	Output mode
	Pulse & Direction 5 V	Emulated Encoder Output (A quad B) 5 V
	Up/Down 5 V	
	Incremental Encoder (A quad B) 5 V	

Connector X7, DIGITAL-IN 1/2 can be configured as an input for 24 V signals.

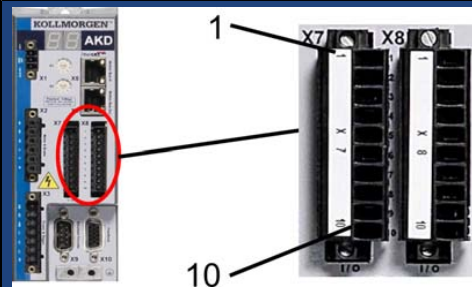
	Input modes X7 DIGITAL-IN 1/2	Output mode
	Pulse & Direction 24 V	
	Up/Down 24 V	
	Incremental Encoder (A quad B) 24 V	

8.15.1 Technical characteristics and pinout

8.15.1.1 Connector X7 Input

Technical characteristics

- Floating, reference common line is DCOM7
- Maximum signal input frequency: 500 kHz
- Sink or Source type connection possible
- High: 15 to 30 V/2 to 15 mA , Low: -3 to 5 V/<15 mA
- Update rate: Hardware 2 μs

Pin	Pulse/Direction	Up/Down	Incremental Encoder
9	Pulse	Up (CW)	Channel A
10	Direction	Down (CCW)	Channel B
1	Common	Common	Common

8.15.1.2 Connector X9 Input

Technical characteristics

- Electrical interface: RS-485
- Maximum signal input frequency: 3MHz
- Input signal voltage range: +12 V to -7 V
- Supply voltage (only applicable to Incremental Encoder Input): +5 V \pm 5%
- Maximum supply current: 250 mA

Pin	Pulse/Direction	Up/Down	Incremental Encoder
1	Pulse+	Up+	A+
2	Pulse-	Up-	A-
3	GND	GND	GND
4	Direction+	Down+	B+
5	Direction-	Down-	B-
6	Shield	Shield	Shield
7	-	-	Zero+
8	-	-	Zero-
9	-	-	+ 5 V encoder supply (output)

NOTICE Maximum cable length of an external incremental encoder using X9 is dependant on cable voltage drop and external encoder power requirements. See the calculation example in the user guide's chapter "Electronic Gearing"

8.15.1.3 Connector X9 Output

Technical characteristics

- Electrical Interface: RS-485
- Max frequency: 3 MHz
- Resolution: Up to 16 bit
- The pulses per revolution value are settable
- Pulse phase shift: $90^{\circ} \pm 20^{\circ}$

Pin	Emulated Encoder Output
1	Channel A+
2	Channel A-
3	GND
4	Channel B+
5	Channel B-
6	Shield
7	Channel Zero+
8	Channel Zero-
9	-

NOTE The maximum permissible cable length is 100 meters.

8.15.2 Command encoder signal connection

8.15.2.1 Incremental encoder input 5 V (X9)

A 5 V A quad B encoder, or the encoder emulation output of another drive can be connected to this input and used as a commander encoder, dual loop feedback, gearing or camming input. Don't use for primary motor feedback connection!

Connection Diagram

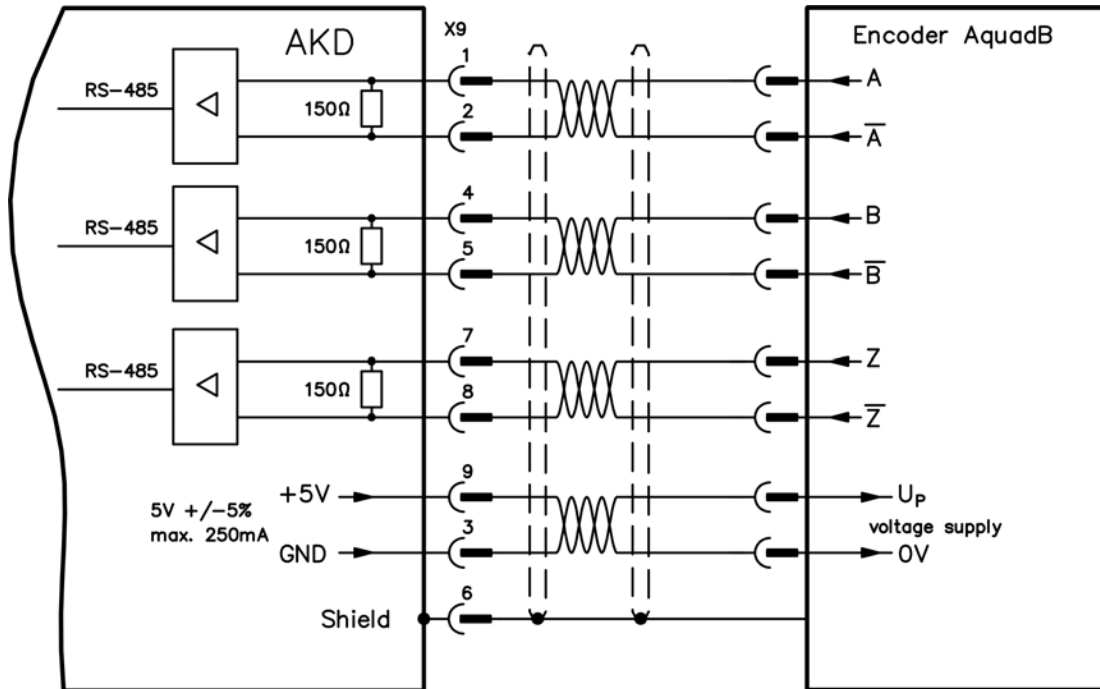

8.15.2.2 Incremental encoder input 24 V (X7)

A 24 V A quad B encoder can be connected to the digital inputs 1 and 2 and used as a commander encoder, dual loop feedback, gearing or camming input. Don't use for primary motor feedback connection!

Connection Diagram

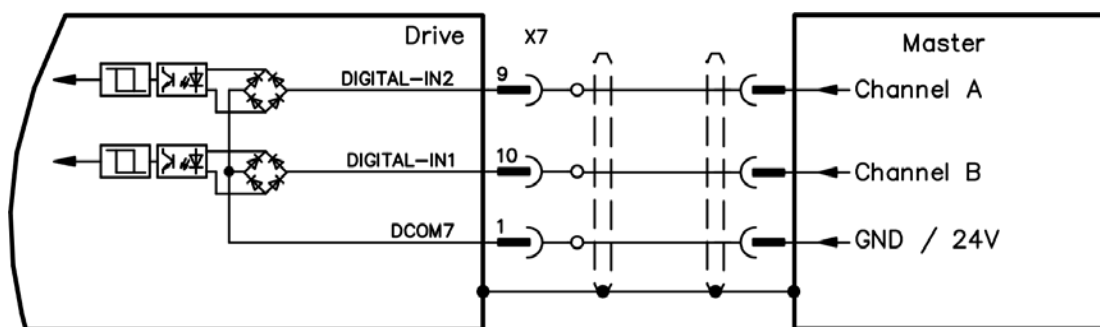

8.15.2.3 Emulated Encoder Output (EEO) - A quad B (X9)

The drive calculates the motor shaft position from the cyclic- absolute signals of the primary feedback, generating incremental-encoder compatible pulses from this information. Pulse outputs on the SubD connector X9 are 3 signals, A, B and Index, with 90° phase difference (i.e. in quadrature, hence the alternative term “A quad B” output), with a zero pulse.

The resolution (before multiplication) can be set by the DRV.EMUERES parameter. Use the DRV.EMUEZOFFSET parameter to adjust + save the zero pulse position within one mechanical turn. The drivers operate from an internal supply voltage.

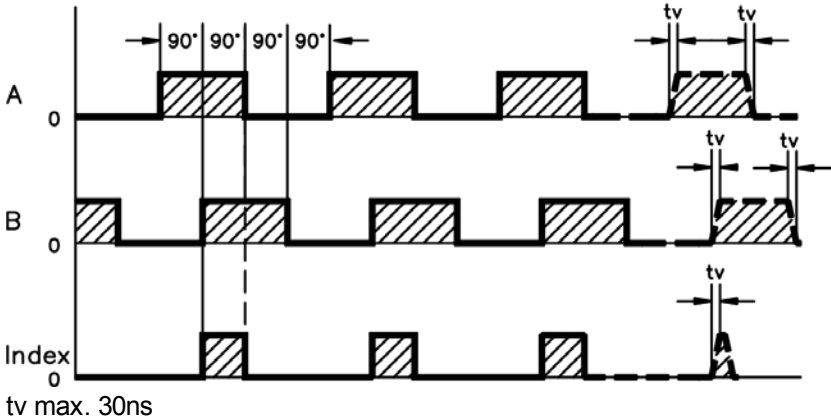

Connection Diagram

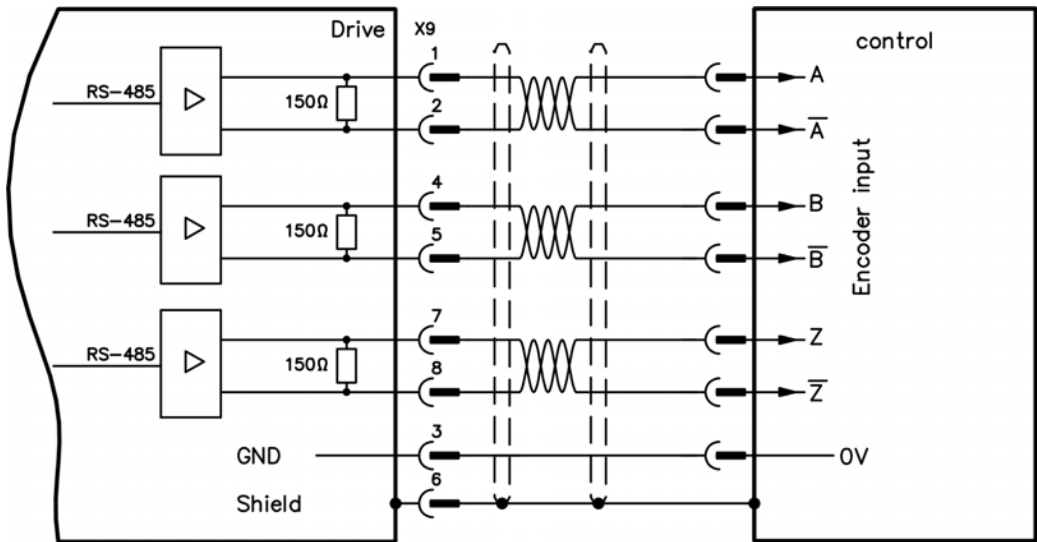

8.15.3 Pulse / Direction signal connection

The drive can be connected to a stepper-motor controller. Set parameters for the drive with WorkBench. The number of pulses can be adjusted, so that the drive can be adapted to match any stepper controller.

Speed profile and signal diagram

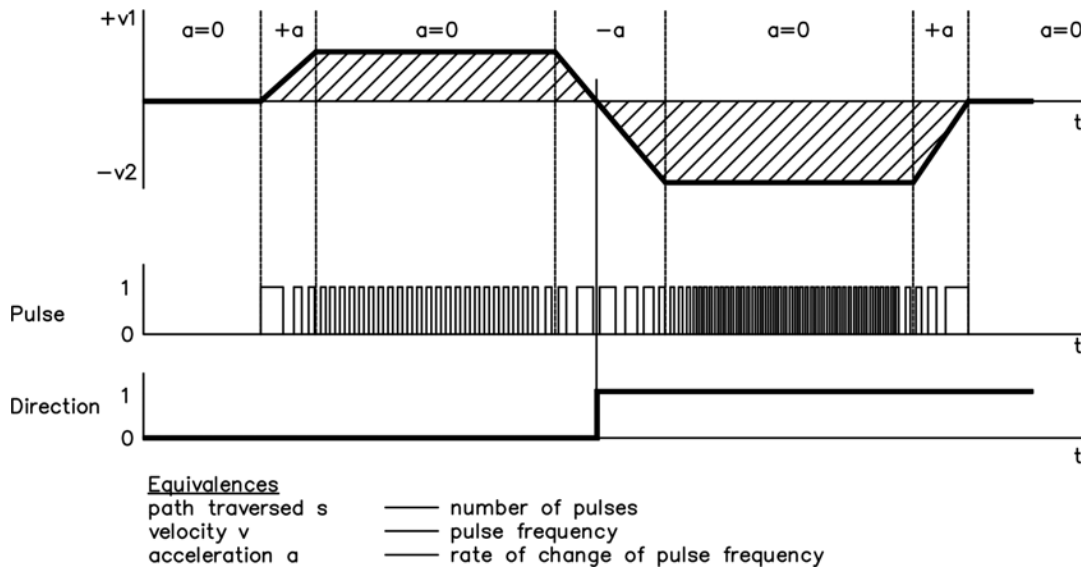

8.15.3.1 Pulse / Direction input 5 V (X9)

Connection to 5 V signal level stepper-motor controllers.

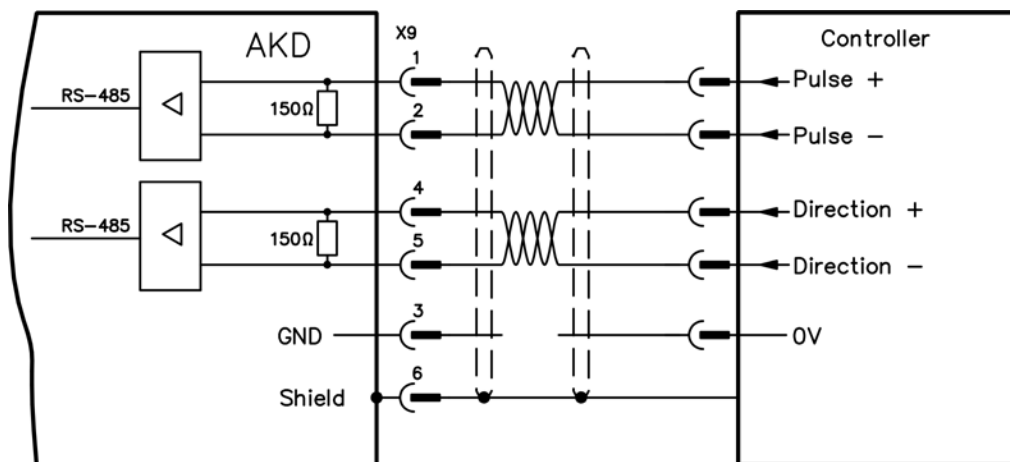

8.15.3.2 Pulse / Direction input 24 V (X7)

Connection to 24 V signal level stepper-motor controllers.

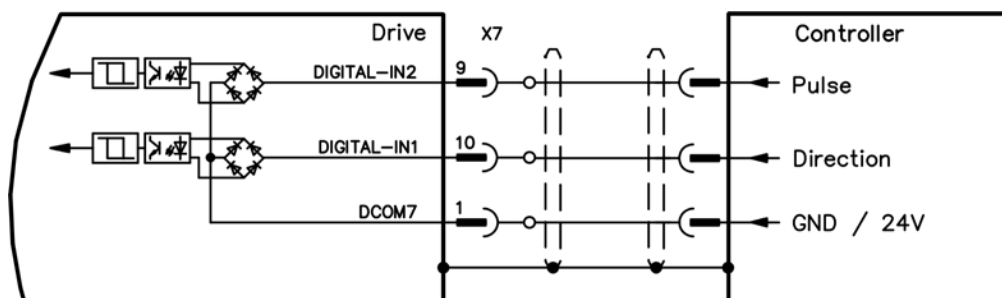

8.15.4 Up / Down signal connection

8.15.4.1 Up / Down input 5 V (X9)

The drive can be connected to a third-party controller which delivers 5 V up-down signals

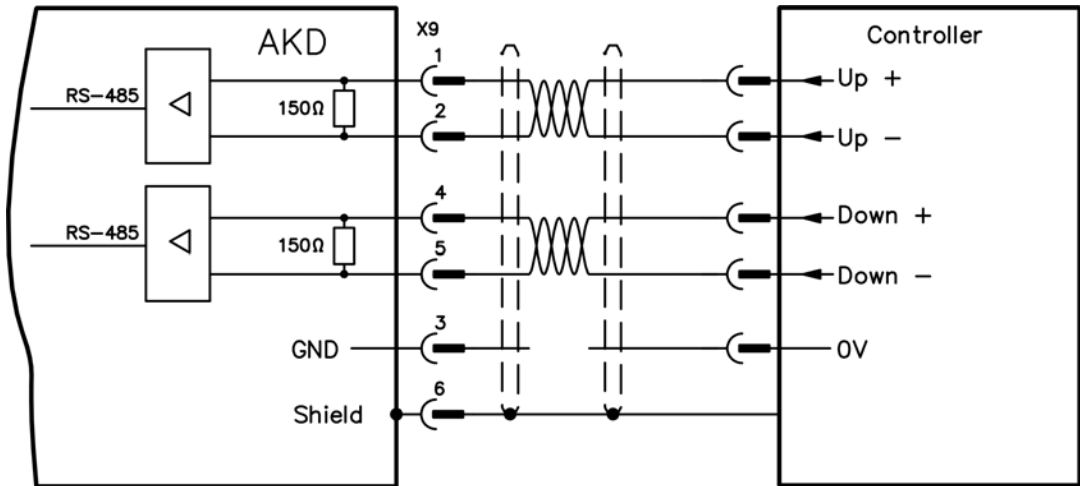

8.15.4.2 Up / Down input 24 V (X7)

The drive can be connected to a third-party controller which delivers 24 V up-down signals.

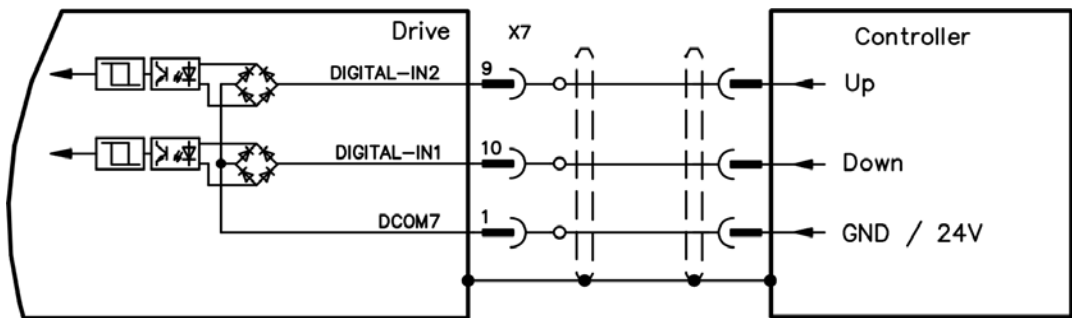

8.15.5 Master-Slave Control

Several AKD can be connected as slave drives to an AKD master. The slave drives use the master's encoder output signals as command input and follow these commands (velocity and direction).

Master-Slave Connection Diagram, example for 5V signal level (X9)

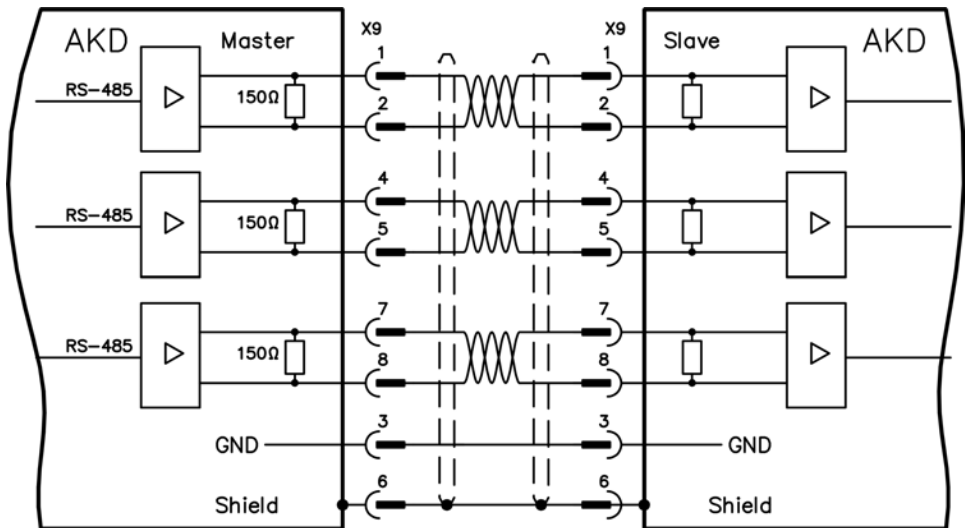

8.16 I/O Connection

All standard digital and analog I/O signals are connected to X7 and X8.

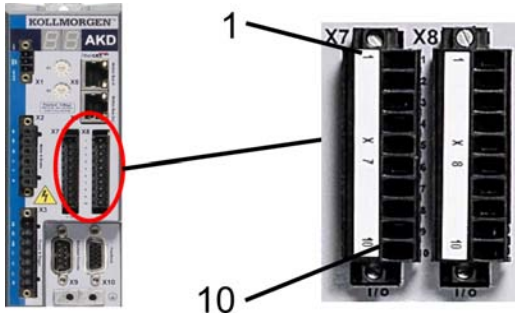

8.16.1 I/O Connectors (X7 and X8)

Conn.	Pin	Signal	Abbreviation	Recommended Function	Specials
X7	1	Digital Common X7	DCOM7	Common line for X7 pins 2, 3, 4, 9, 10	N/A
X7	2	Digital Input 7	DIGITAL-IN 7	Programmable	N/A
X7	3	Digital Input 4	DIGITAL-IN 4	Programmable	N/A
X7	4	Digital Input 3	DIGITAL-IN 3	Programmable	N/A
X7	5	Digital Output 2-	DIGITAL-OUT2-	Programmable	N/A
X7	6	Digital Output 2+	DIGITAL-OUT2+	Programmable	N/A
X7	7	Digital Output 1-	DIGITAL-OUT1-	Programmable	N/A
X7	8	Digital Output 1+	DIGITAL-OUT1+	Programmable	N/A
X7	9	Digital Input 2	DIGITAL-IN 2	Reference point	high speed
X7	10	Digital Input 1	DIGITAL-IN 1	Home switch	high speed
X8	1	Fault Relay Output	Fault Relay Output	N/A	N/A
X8	2	Fault Relay Output	Fault Relay Output	N/A	N/A
X8	3	Digital Common X8	DCOM8	Common line for X8 pins 4, 5, 6	N/A
X8	4	Digital Input 8	DIGITAL-IN 8	Output stage enable	not programmable
X8	5	Digital Input 6	DIGITAL-IN 6	Negative limit switch	N/A
X8	6	Digital Input 5	DIGITAL-IN 5	Positive limit switch	N/A
X8	7	Analog Ground	AGND	Analog GND	N/A
X8	8	Analog Output +	Analog-Out	Actual velocity voltage	N/A
X8	9	Analog Input -	Analog-In-	Velocity set point	N/A
X8	10	Analog Input +	Analog-In+		N/A

Digital common lines for X7 and X8 are not common to each other.

The DCOMx lines should be connected to the 0V of the I/O supply when using sensors of type "Source" with digital inputs.

The DCOMx lines should be connected to the 24V of the I/O supply when using sensors of type "Sink" with digital inputs.

8.16.2 Analog Input (X8)

The drive is fitted with one differential input for analog torque, velocity, or position control.

Technical characteristics

- Differential-input voltage max.: ± 10 V
- Resolution: 16 Bit
- Accuracy: 13 Bit
- Input resistance: 30 kohms
- Common-mode voltage range for both inputs: ± 10 V
- Update rate: 25 μ s

Analog Input Wiring Diagram

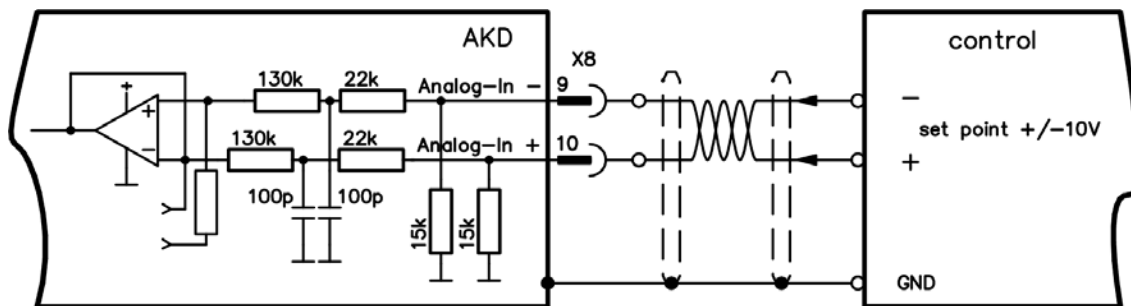

Application examples for set point input Analog-In:

- adjustable external current limit
- reduced-sensitivity input for setting-up/jog operation
- pre-control/override

Defining the direction of rotation

Standard setting: clockwise rotation of the motor shaft (looking at the shaft end) affected by positive voltage between terminal X8/10 (+) and terminal X8/9 (-)

To reverse the direction of rotation, swap the connections to terminals X8/9-10, or change the DRV.DIR parameter in the "Feedback" screen page.

8.16.3 Analog Output (X8)

Terminals X8/7-8 can be used to output converted analog values of digital measurements recorded in the drive. A list of the pre-programmed functions is included in the WorkBench setup software.

Technical characteristics

- Differential-output voltage max.: ± 10 V
- Resolution: 16 Bit
- Accuracy: < 0.05 V
- Output impedance: < 10 ohms
- Specification complies with IEC 61131-2 Table 11
- Frequency response: 4 kHz
- Maximum output current: > 10 mA
- Maximum capacitive load: 10 nF
- Current protected

Analog Output Wiring Diagram

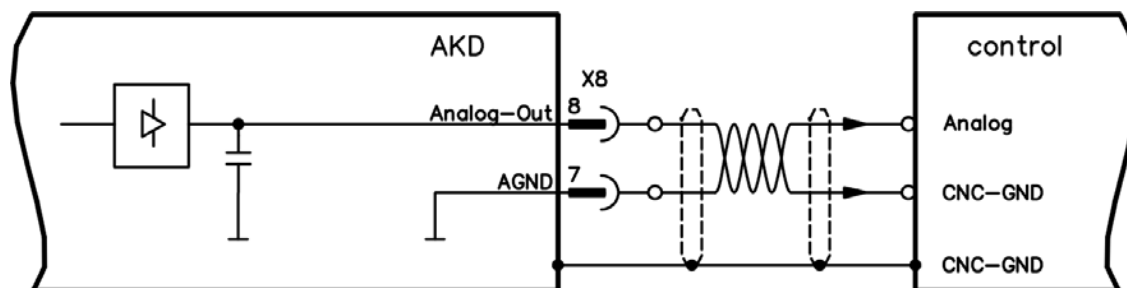

8.16.4 Digital Inputs (X7/X8)

The drive provides 8 digital inputs (=> p. 110). These can be used to initiate pre-programmed functions that are stored in the drive. A list of these pre-programmed functions is included in the WorkBench. Digital Input 8 is not programmable but is fixed to the ENABLE function. If an input is programmed, it must be saved to the drive.

NOTE Depending on the selected function the inputs are high or low active.

The inputs can be used with switched +24 V (source type) or switched GND (sink type). See diagrams below.

Digital Input Wiring Diagram (Source type connection)

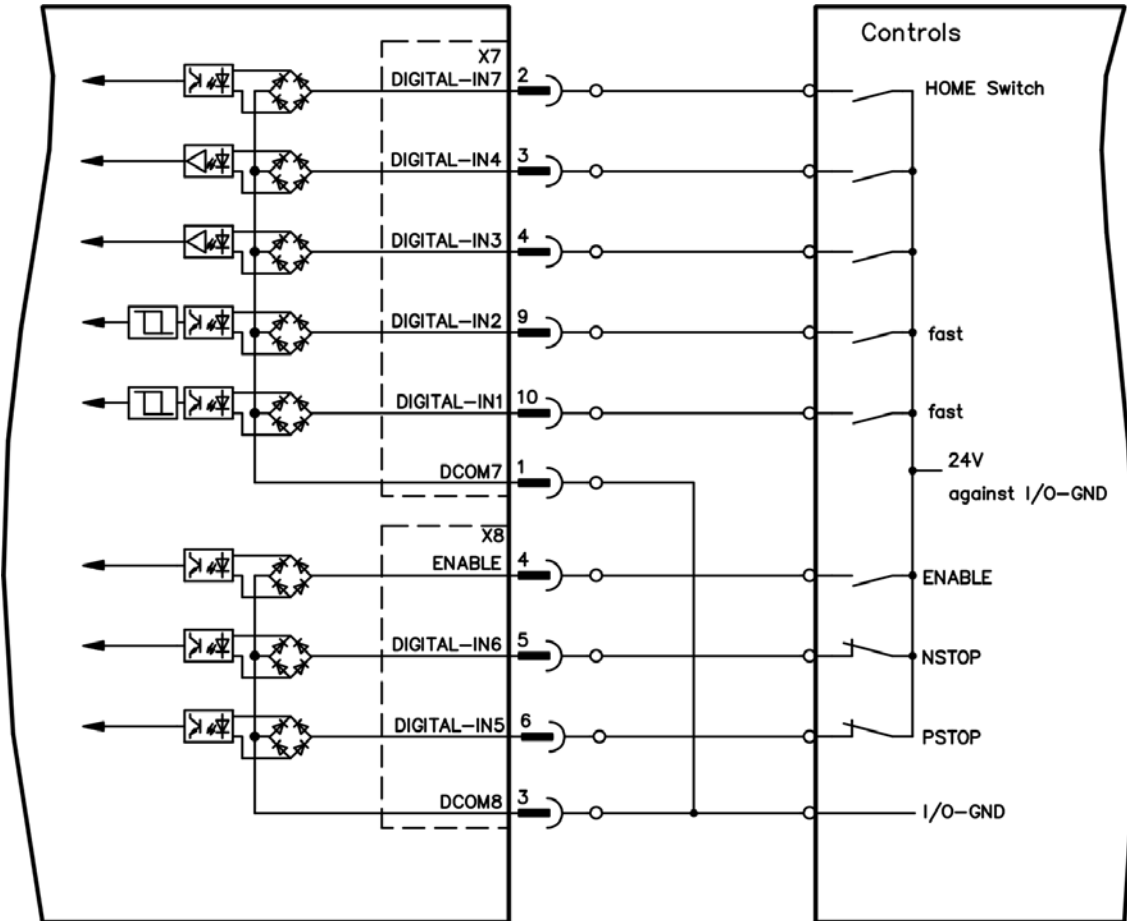

Digital Input Wiring Diagram (Sink type connection)

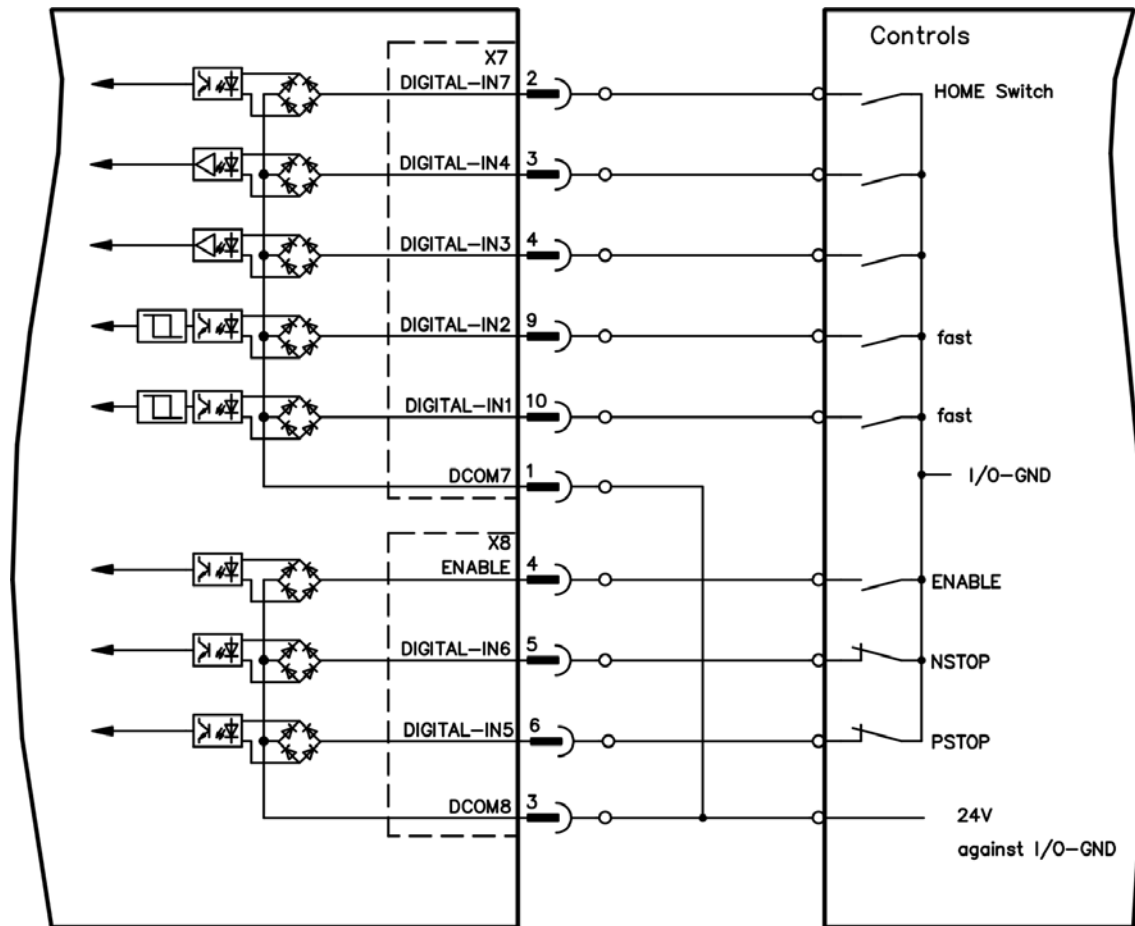

8.16.4.1 Digital Inputs 1 and 2

These inputs (X7/9 and X7/10) are particularly fast and are therefore suitable for latch functions, for example. They can also be used as 24 V inputs for electronic gearing (=> p. 104)

Technical characteristics

- Floating, reference common line is DCOM7
- Sink or Source type sensors possible
- High: 3.5 to 30 V/2 to 15 mA , Low: -2 to +2 V/<15 mA
- Update rate: Hardware 2 μ s

8.16.4.2 Digital Inputs 3 to 7

These inputs are programmable with the setup software. By default, all inputs are not programmed (off). For more information refer to the setup software.

Technical characteristics

Choose the function you require in WorkBench.

- Floating, reference common line is DCOM7 or DCOM8
- Sink or Source type sensors possible
- High: 3.5 to 30 V/2 to 15 mA , Low: -2 to +2 V/<15 mA
- Update rate: Software 250 μ s

8.16.4.3 Digital Input 8 (ENABLE)

Digital Input 8 (terminal X8/4) is set to Enable function.

- Floating, reference common line is DCOM8
- Sink or Source type wiring is possible
- High: 15 to 30 V/2 to 15 mA , Low: -3 to 5 V/<15 mA
- Update rate: direct connection to hardware (FPGA)

The output stage of the drive is enabled by applying the ENABLE signal (Terminal X8/4, active high). Enable is possible only if input STO has a 24 V signal (=> p. 53). In the disabled state (low signal) the connected motor has no torque.

A software enable by means of the setup software is also required (AND link), although this can also be permanently enabled with WorkBench.

8.16.5 Digital Outputs (X7/X8)

8.16.5.1 Digital Outputs 1 and 2

The drive supplies 2 digital outputs (X7/5 to X7/8, => p. 110). Choose the required function in the setup software. Messages from pre-programmed functions stored in the drive can be output here. A list of these pre-programmed functions can be found in the setup software. If an output is to be assigned to a pre-programmed function, then the parameter set must be saved in the drive.

Technical characteristics

- 24 V IO power supply at terminals X7/8 and X7/6, 20 Vdc to 30 Vdc
- All digital outputs are floating, DIGITAL OUT 1/2: terminals X7/7-8 and X7/5-6), max. 100 mA
- Can be wired as active low or active high (see examples below)
- Update rate: 250 μ s

Wiring diagram

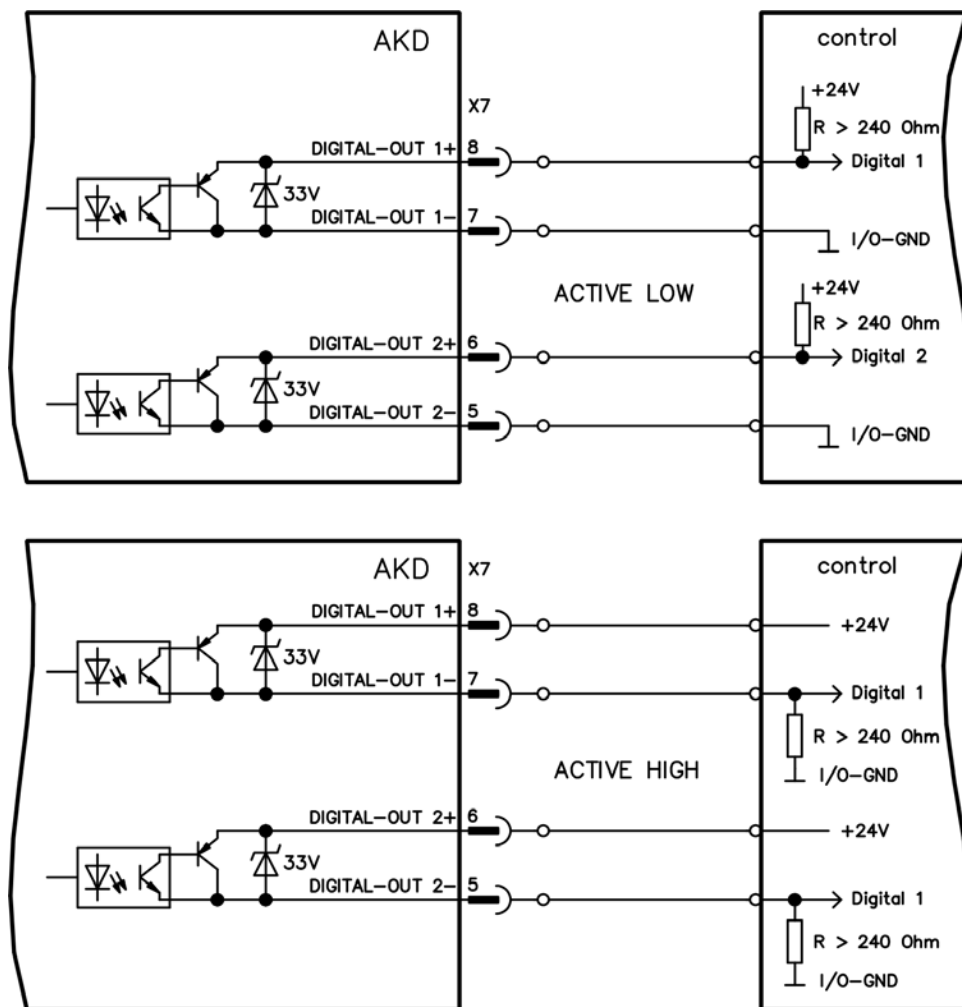

8.16.5.2 FAULT relay contacts

Operational readiness (terminals X8/1 and X8/2) is signaled by a floating relay contact.

The fault relay can be programmed to two modes of operation:

- Contact closed when there is no fault
- Contact closed when there is no fault and the drive is enabled.

The signal is not influenced by the enable signal, the I²t-limit, or the brake threshold.

Technical characteristics

- FAULT: Relay output, max. 30 Vdc or 42 Vac, 1 A
- Time to close: max. 10 ms
- Time to open: max. 10 ms

NOTE

All faults cause the FAULT contact to open and the output stage to be switched off (if the FAULT contact is open, the output stage is inhibited -> no power output).
List of the fault messages: => p. 133.

Wiring diagram

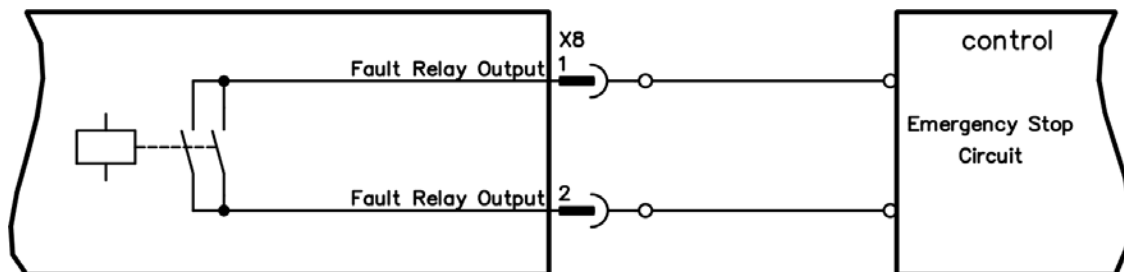

8.17 Service Interface (X11)

Operating, position control, and motion-block parameters can be set up by using the setup software on an ordinary commercial PC ("Hardware requirements" => p. 128).

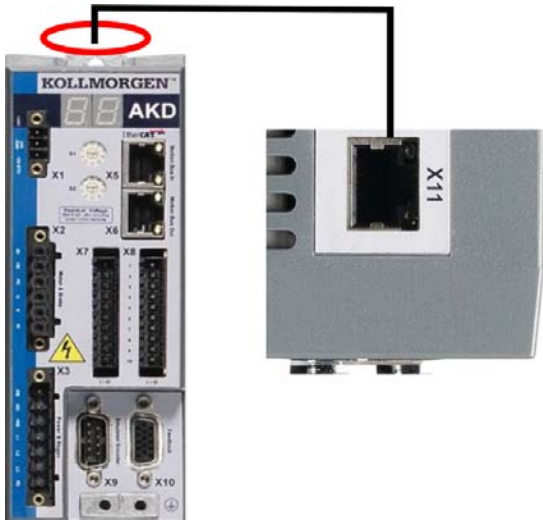

Connect the service interface (X11) of the drive to an Ethernet interface on the PC directly or via a network hub/switch, **while the supply to the equipment is switched off**. Use standard Cat. 5 Ethernet cables for either connection configuration but note that in most cases crossover cables will also work.

Confirm that the link LED on the AKD (the green LED on the RJ45 connector) and on your PC (or network Hub/Switch) are both illuminated. If both lights are illuminated, then you have a good electrical connection.

8.17.1 Possible Network Configurations

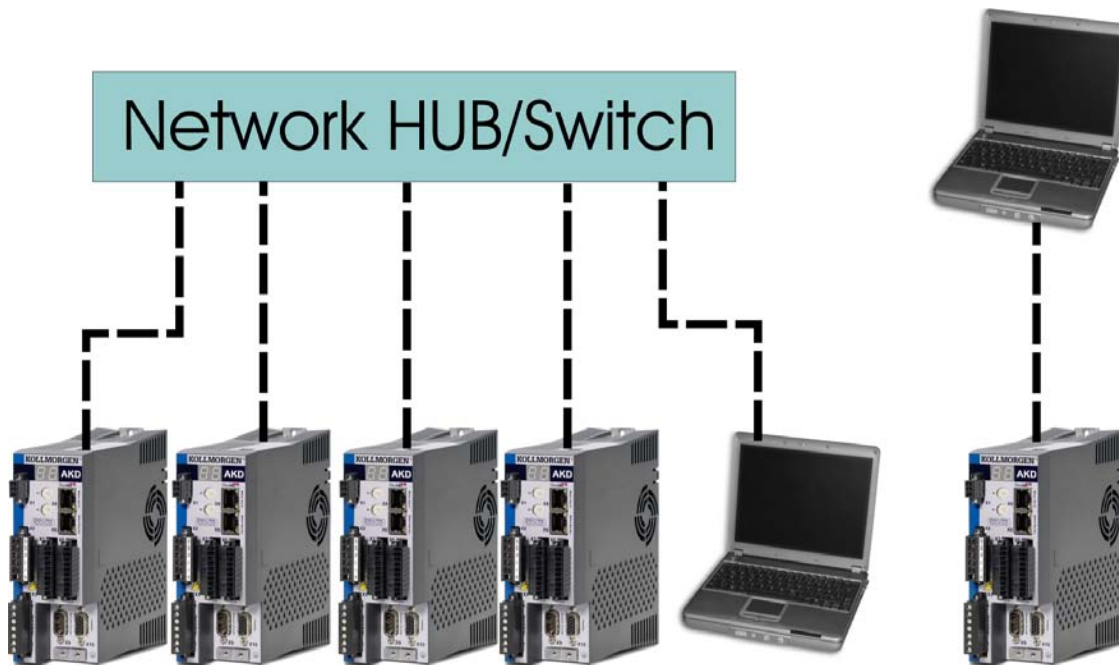

8.17.2 Setting the IP Address with Rotary Switches

You can use the fieldbus to select the IP address value or IP address mode for accessing the drive over the service interface. For CANopen and some other fieldbuses, the rotary switches also set the node address of the drive for that specific network.

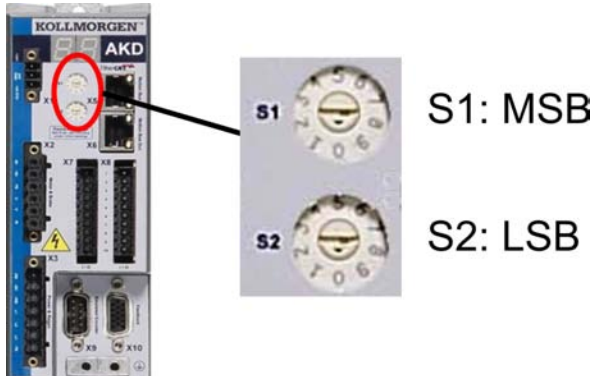

Rotary Switch Setting	Drive IP Address
00	DHCP/AutoIP address. The IP address of the drive is obtained from the DHCP server on your network. If no DHCP server is found the IP addresses is an AutoIP address (it is internally generated following the AutoIP protocol and will be of the form 169.254.xx.xx).
01 to 99	Static IP Address. The IP address is 192.168.0.nn, where nn is the number from the rotary switch. This setting generates addresses in a range from 192.168.0.2 to 192.168.0.99. Example:if S1 is set to 0 and S2 is set to 5 – the IP address is 192.168.0.5
NOTE	The PC subnet mask must be set to 255.255.255.0 or 255.255.255.128
NOTE	When connecting the AKD directly to a PC, use static IP addressing (not 00).

Dynamic IP addressing (DHCP and Auto-IP)

With S1 and S2 both set to 0, the drive is in DHCP mode. The drive will acquire its IP address from an external DHCP server if present in the network. If a DHCP server is not present, the drive will assume an Automatic Private IP Address of the form 169.254.x.x.

If your PC is directly connected to the drive, and set to obtain an IP address automatically in the TCP/IP settings, a connection will be established with both devices using compatible automatic generated addresses. It can take up to 57 seconds for a PC to configure an Automatic Private IP Address (169.254.x.x).

Changing the IP address

If the switches are altered while 24 V Logic power is supplied to the drive, you must unplug the network cable from the drive for 3 seconds or more. This action will reset the address.

8.18 CANbus Interface (X12/X13)

Two 6-pin RJ-12 connectors X12/X13 are used for CANbus connection. The integrated profile is based on the CANopen DS301 communication profile and the DS402 drive profile (default 125 kBaud). The following functions are available in connection with the position controller: jogging with variable speed, homing run (zeroing to reference), start motion task, start direct task, digital setpoint provision, data transmission functions, and others. Detailed information is included in the CANopen documentation.



Conn.	Pin	Signal	Conn.	Pin	Signal
X12	1	Internal Termination Resistor	X13	1	Internal Termination Resistor
X12	2	CAN Shield	X13	2	CAN Shield
X12	3	CANH in	X13	3	CANH out
X12	4	CANL in	X13	4	CANL out
X12	5	GND	X13	5	GND
X12	6	Internal Termination Resistor	X13	6	Internal Termination Resistor

8.18.1 Transmission Rate for CANbus

The setup software is used to set all parameters. The transmission rate can be set via the parameter **FB.PARAM01**. The values 125, 250, 500 and 1000 for the identical baudrate in kBit/s are possible.

8.18.2 Node Address for CANbus

NOTE After changing the node address, you must turn off the 24 V auxiliary supply for the drive and then turn it on again.

During setup, use the rotary switches on the AKD front panel to preset the station address for communication.

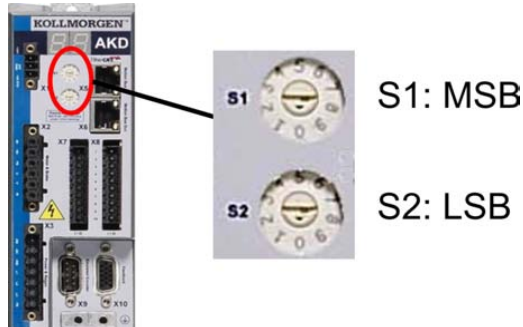

The rotary switches on the front of the AKD (S1&S2) correspond to the CAN node address.

The S1&S2 switches also correspond to the IP address setting of the drive. Both CAN and IP network address schemes have to be configured to account for this dependence if both TCP/IP and CAN networks are running at the same time in an application.

Example:

S1 (MSB)	S2 (LSB)	CAN address	IP address
4	5	45	192.168.0.45

8.18.3 CANbus Termination

The last bus device on both ends of the CANbus system must have termination resistors. The AKD has built-in 132 ohms resistors that can be activated by connecting pins 1 and 6. An optional termination plug is available for AKD (*P-AKD-CAN-TERM*). The optional termination plug is an RJ-12 connector with an enclosed wire jumper between pins 1&6. A plug should be inserted into the X13 connector of the last drive in the CAN network.

NOTE Remove the termination connector if the AKD is not the last CANbus device and use X13 for connecting the next CAN node.

8.18.4 CANbus Cable

To meet ISO 11898, a bus cable with a characteristic impedance of 120 ohms should be used. The maximum usable cable length for reliable communication decreases with increasing transmission speed. As a guide, you can use the following values which Kollmorgen™ has measured; however, these values are not assured limits:

Cable data:

- Characteristic impedance: 100–120 ohms
- Cable capacitance max.: 60 nF/km
- Lead loop resistance: 159.8 ohms/km

Cable length, depending on the transmission rate:

Transmission Rate (kBaud)	Maximum Cable Length (m)
1,000	10
500	70
250	115

Lower cable capacitance (max. 30 nF/km) and lower lead resistance (loop resistance, 115 ohms/1000m) make it possible to achieve greater distances.

(Characteristic impedance 150 ± 5 ohms requires terminating resistor 150 ± 5 ohms).

8.18.5 CAN Bus Wiring

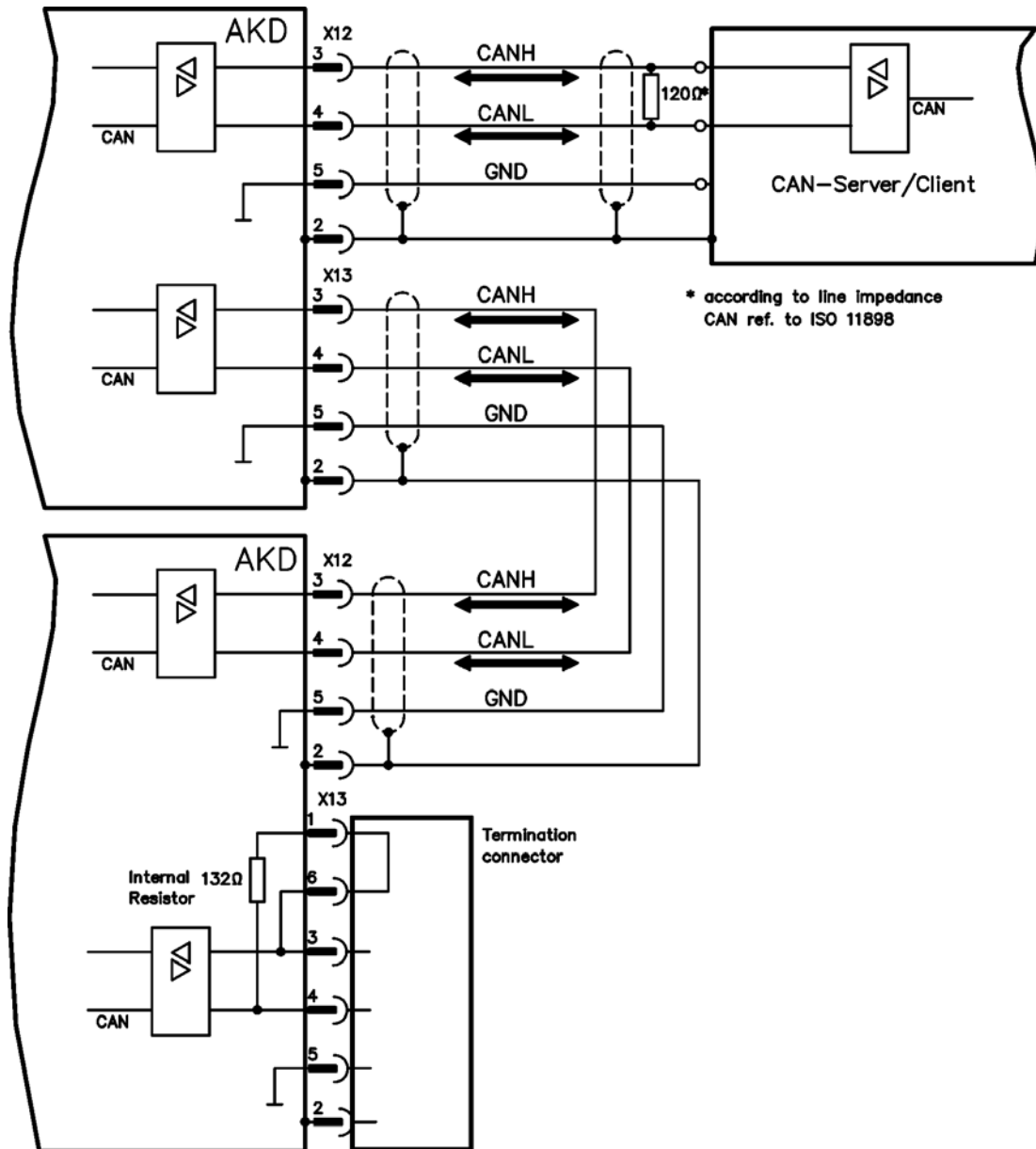

8.19 Motion Bus Interface (X5/X6)

The motion bus interface has two RJ-45 connectors and can be used for communicating with various fieldbus devices depending on the used drive version.

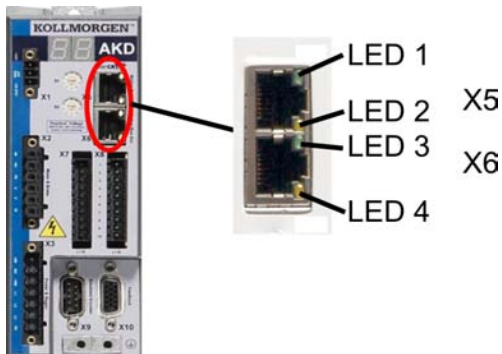

NOTICE

Do not connect the Ethernet line for the PC with the set up software to the motion bus interface. The set up Ethernet cable must be connected to the service interface on X11

8.19.1 Pinout X5/X6

Pin	Signal X5	Signal X6
1	Transmit +	Receive+
2	Transmit -	Receive-
3	Receive+	Transmit +
4	n.c.	n.c.
5	n.c.	n.c.
6	Receive-	Transmit -
7	n.c.	n.c.
8	n.c.	n.c.

8.19.2 Optional Motion Bus Protocols

Motionbus	Connector	Location	Connectivity Option
EtherCAT	X5/X6	Base housing	EC
SynqNet	X5/X6	Base housing (in process)	SQ
ProfiNet CBA		in process	P0
ProfiNet RT		in process	P1
ProfiNet IRT		in process	P2
SERCOS III		in process	S3
EtherNet IP (A-B)		in process	EP
PowerLink		in process	PK

8.19.3 EtherCAT

You can connect to the EtherCAT network via RJ-45 connectors X5 (in port) and X6 (out port). The communication status is indicated by the built-in LEDs.

Connector	LED#	Name	Function
X5	LED1	IN port Link	ON = active OFF = not active
	LED2	RUN	ON = running OFF = not running
X6	LED3	OUT port Link	ON = active OFF = not active
	LED4	-	-

8.19.4 SynqNet (in process)

You can connect to the SynqNet Network via RJ-45 connectors X5 (in port) and X6 (out port). The communication status is indicated by the built-in LEDs.

Connector	LED#	Name	Function
X5	LED1	LINK_IN	ON = receive valid (IN port) OFF = not valid, power off, or reset.
	LED2	CYCLIC	ON = network cyclic BLINK = network not cyclic OFF = power off, or reset
X6	LED3	LINK_OUT	ON = receive valid (OUT port) OFF = not valid, power off, or reset
	LED4	REPEATER	ON = repeater on, network cyclic BLINK = repeater on, network not cyclic OFF = repeater off, power off, or reset

8.19.5 Motion Busses in Process

8.19.5.1 PROFINET CBA/RT/IRT (in process)

8.19.5.2 SERCOS III (in process)

8.19.5.3 Ethernet IP (A-B, in process)

8.19.5.4 Powerlink (in process)

8.19.5.5 Modbus TCP/IP (in process)

9 Setup

9.1 Safety Instructions	126
9.2 Setup software (WorkBench)	127
9.3 Basic Drive Test	130
9.4 Fault and Warning Messages	133
9.5 Troubleshooting the AKD	139

The procedure for setup is a typical example. Depending on the application, a different procedure may be appropriate or necessary; consult technical support for assistance if this example does not apply to your application. In multi-axis systems, set up each drive individually.

9.1 Safety Instructions

⚠ DANGER The equipment produces potentially lethal voltages up to 900 V. Check that all connection components that are live in operation are safely protected against bodily contact.

Never remove the electrical connections to the drive while it is live.

Capacitors can still have dangerous residual charges up to 7 minutes after switching off the supply voltage.

⚠ CAUTION The heat sink of the drive can reach temperatures up to 80°C in operation. Check the heat sink temperature before handling the drive. Wait until the heat sink has cooled down to 40 °C before touching it.

⚠ CAUTION Before testing and setup, the manufacturer of the machine must generate a hazard analysis for the machine and take appropriate measures so that unforeseen movements cannot cause injury or damage to any person or property.

⚠ CAUTION Only professional personnel with extensive knowledge in the fields of electrical engineering and drive technology are allowed to test and set up the drive.

NOTICE If the drive has been stored for more than 1 year, you must re-form the capacitors in the DC bus link circuit. To re-form the capacitors, disconnect all electrical connections and apply single-phase 208 to 240 Vac to terminals L1/L2 of the drive for about 30 minutes.

NOTE Additional information on setting up the equipment:

- Programming parameters and control loop behavior are described in the online help of the setup software.
- The setup of any expansion card described in the corresponding manual on the CD-ROM.
- Kollmorgen™ can provide training courses for the drive upon request.

9.2 Setup software (WorkBench)

This chapter describes the installation of the setup software WorkBench for the AKD digital drives. Kollmorgen™ offers training and familiarization courses on request.

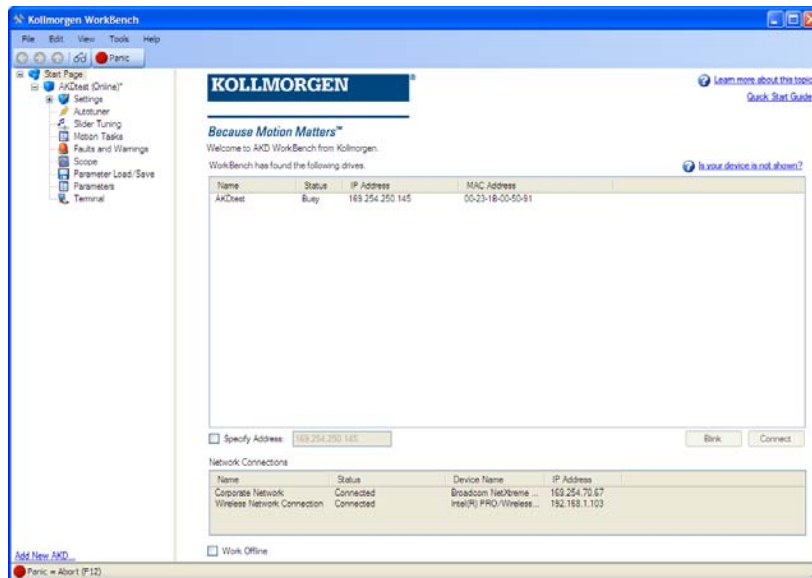

9.2.1 Use as directed

The setup software is intended to be used for altering and saving the operating parameters for the AKD series of drives. The attached drive can be set up with the help of this software, and during this procedure the drive can be controlled directly by the service functions.

⚠ WARNING Only professional personnel who have the relevant expertise (=> p. 10) are permitted to carry out online parameter setting for a drive that is running. Sets of data that have been stored on data media are not safe against unintended alteration by other persons. Unexpected move could be the result if you use unchecked data. After loading a set of data you must therefore always check all parameters before enabling the drive.

9.2.2 Software description

Each drive must be adapted to the requirements of your machine. For most applications, you can use a PC and WorkBench (the drive setup software) to set up the operating conditions and parameters for your drive. The PC is connected to the drive by an Ethernet cable (=> p. 118). The setup software provides the communication between the PC and AKD. You can find the setup software on the accompanying CD-ROM and in the download area of the Kollmorgen™ website.

With very little effort you can alter parameters and instantly observe the effect on the drive, since there is a continuous (online) connection to the drive. You can also read important actual values from the drive, which are displayed on the monitor of the PC (oscilloscope functions).

You can save sets of data on data media (archiving) and load them into other drives or use them for backup. You can also print out the data sets.

Most standard feedbacks (SFD, EnDAT 2.2, 2.1, and BiSS) are plug and play compatible. Motor nameplate data is stored in the feedback device and read by the drive automatically at startup. Non-plug and play Kollmorgen™ motors are stored in WorkBench and can be loaded with one-click using the Motors screen in the WorkBench software.

An extensive online help with integrated description of all variables and functions supports you in each situation.

9.2.3 Hardware requirements

The Service interface (X11, RJ45) of the drive is connected to the Ethernet interface of the PC by an Ethernet cable (=> p. 118).

Minimum requirements for the PC:

Processor: at least Pentium® II or comparable

Operating system : Windows 2000 or XP or VISTA or 7

Graphics adapter : Windows compatible, color

Drives : hard disk with at least 20 MB free space, CD-ROM drive

Interface : one free Ethernet Interface, or a Hub port or Switch port

9.2.4 Operating systems

WINDOWS 2000/XP/VISTA/7

WorkBench works with WINDOWS 2000, WINDOWS XP, WINDOWS VISTA and WINDOWS 7

Unix, Linux

The functioning of the software has not been tested for WINDOWS running within Unix or Linux.

9.2.5 Installation under WINDOWS 2000/XP/VISTA/7

The CD-ROM includes an installation program for the setup software.

Installation

- Autostart function activated:
Insert the CD-ROM into a free drive. A window with the start screen opens. There you find a link to the setup software WorkBench. Click it and follow the instructions.
- Autostart function deactivated:
Insert the CD-ROM into a free drive. Click **Start** (task bar), then **Run**. Enter the program call: x:\index.htm (x = correct CD drive letter).
Click **OK** and proceed as described above.

Connection to the Ethernet interface of the PC

- Connect the interface cable to an Ethernet interface on your PC or to a Hub/Switch and to the service interface X11 of the AKD (=> p. 118).

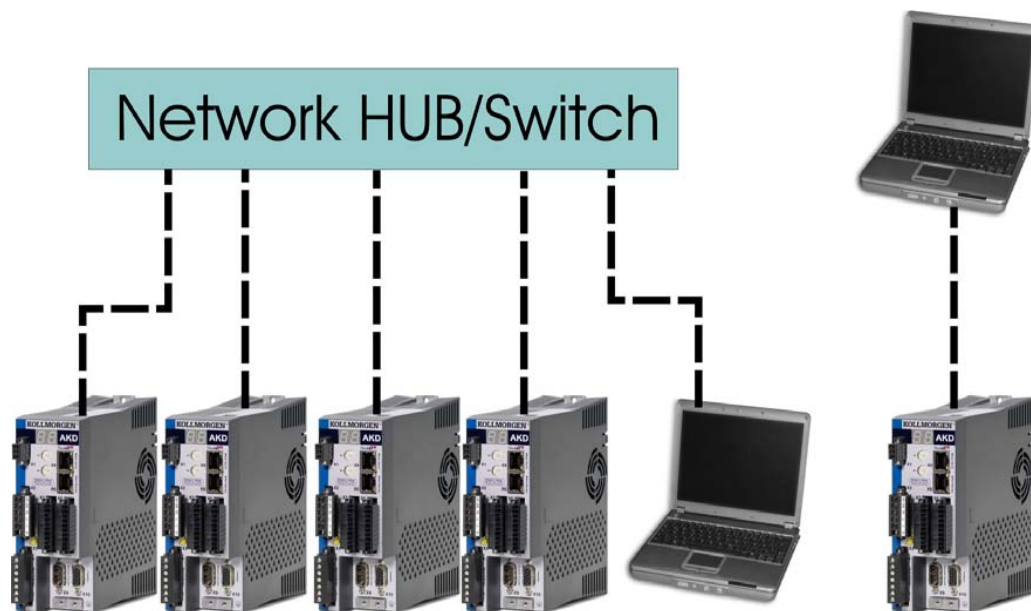

9.3 Basic Drive Test

9.3.1 Unpacking, Mounting, and Wiring the Drive

1. Unpack drive and accessories. Observe safety instructions in the documentation.
2. Mount the drive (=> p. 60).
3. Wire the drive (=> p. 72) or apply the minimum wiring for drive testing as described below.
4. Make sure you have on hand the following information about the drive components:
 - rated mains supply voltage
 - motor type (motor data, if the motor type is not listed in the motor database)
 - feedback unit built into the motor (type, poles/lines/protocol)
 - moment of inertia of the load

9.3.2 Minimum Wiring for Drive Test without Load

CAUTION This wiring diagram is for general illustration only and does not fulfill any requirements for EMC, safety, or functionality of your application.

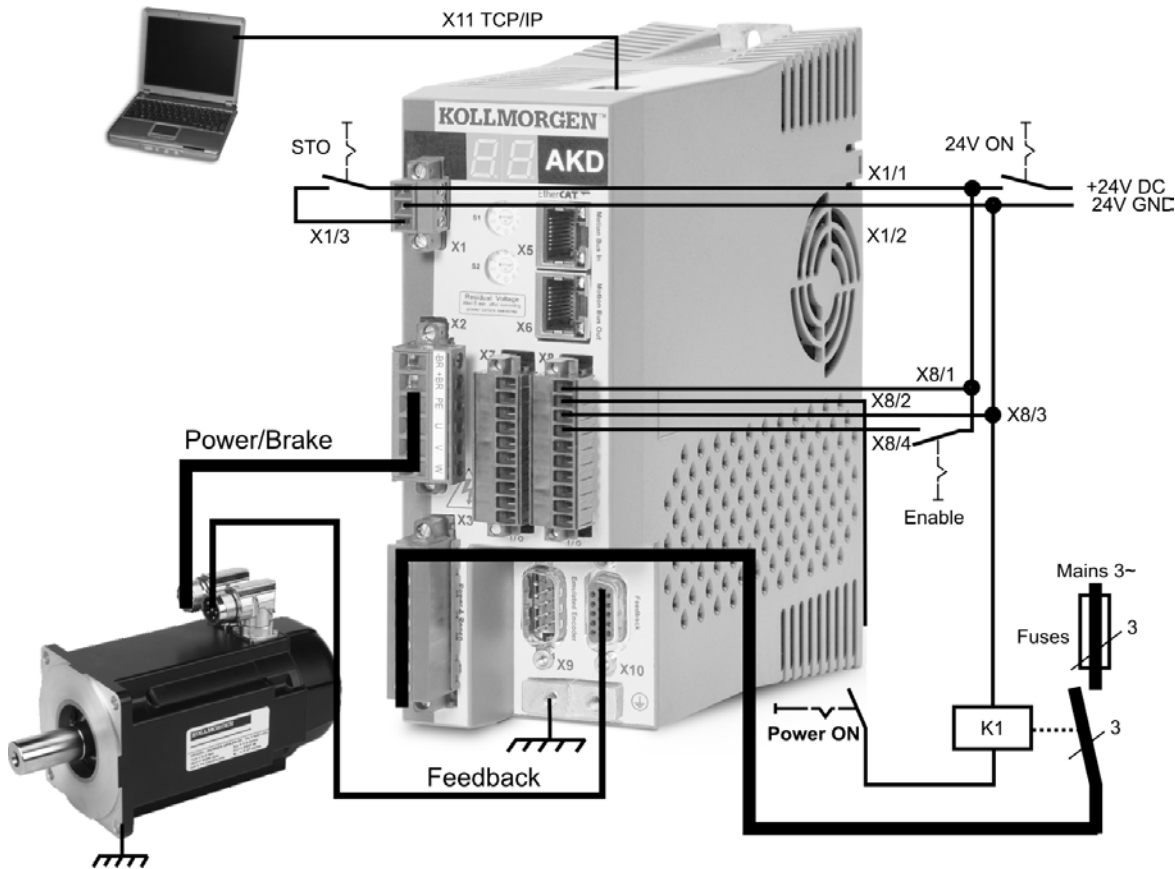

When connecting the AKD directly to a PC, static IP addressing (not 00) is recommended.

9.3.3 Testing Procedure

9.3.3.1 Confirm Connections

You can turn on logic power to the drive through the X1 connector (bus voltage is not needed for communications).

After power is supplied, the drive displays a sequence of LED flashes:

1. –
2. []
3. I-P
4. Drive IP address, flashed sequentially (for example, 192.168.0.5).
5. Drive status (opmode "o0", "o1", or "o2") or fault code if the drive is in a fault condition.

Confirm that the link LEDs on the drive (green LED on the RJ45 connector) and on your PC are both illuminated. If both LEDs are illuminated, then you have a working electrical connection.

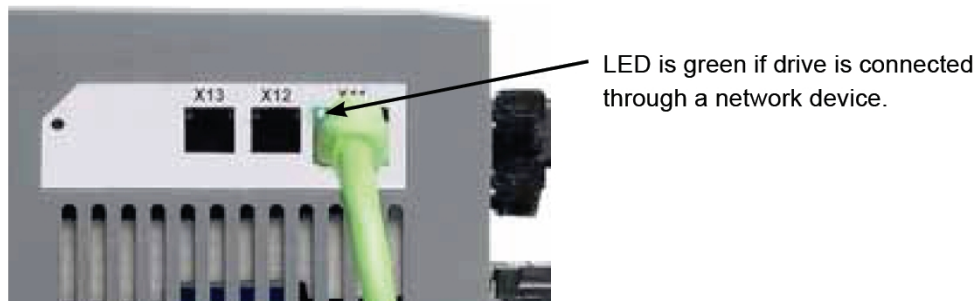

While the PC is connecting, your taskbar will show the following acquiring icon:



Wait for this icon to change to the limited functionality icon (this process can take up to one minute).



Although Windows displays this limited functionality icon for the drive connection, the PC can communicate fully with the drive. Using WorkBench, you can now configure the drive through this connection.

9.3.3.2 Install and Start WorkBench

WorkBench installs automatically from the CD included with the drive. WorkBench is also available on the Kollmorgen™ Web site: www.kollmorgen.com.

Once installation is complete, click the WorkBench icon to start the program. WorkBench will show a list of all the drives that it can find on your local network. Select the drive you wish to configure and then click **Next**.

If multiple drives are detected, a drive can be uniquely identified using one of the following methods:

1. The MAC address of the drive. This address is printed on the sticker on the side of the drive.
2. The name of the drive. The drive name is set using WorkBench. A new drive defaults to "No_Name."
3. Blinking the display. Select a drive and click **Blink** to force the display on the front of the drive to blink on and off for 20 seconds.

9.3.3.3 Set Drive IP Address in WorkBench

If WorkBench does not automatically show your drive, then you can set the IP address manually in WorkBench as follows:

1. Display the IP address. You can show the drive IP address on the drive display by pressing button B1. The display shows the digits and dots of the IP address in sequence (for example, 192.168.0.5). You can also display the IP address by disconnecting and then reconnecting the Ethernet cable.



2. Enter the drive IP address. Once the IP address has been determined, manually enter the drive IP address into the **Specify Address** box in WorkBench. Then click **Next** to connect.

9.3.3.4 Enable the Drive Using the Setup Wizard.

Once a connection to the drive has been established, the AKD Overview screen appears. Your drive appears in the navigation area on the left of the screen. Right click on your drive name and select **Setup Wizard** from the drop-down menu. The Setup Wizard guides you through the initial drive configuration, which includes a simple test motion.

After completing the Setup Wizard, your drive should be enabled. If the drive is not enabled, check the following:

1. The hardware enable (HW) must be in the enabled state (pin 4 on X8 connector).
2. The software enable (SW) must be in the enabled state. Activate using the **Enable/Disable** button on the upper toolbar on WorkBench or in the Overview screen.
3. No faults may be present (click the **Clear Fault** button on the upper tool bar to clear any faults).

The status of HW enable, SW enable, and Faults is displayed in the lower toolbar of the WorkBench software. The drive is connected if the lower right corner shows **Online**.

You can now use the Settings View in WorkBench to complete advanced configuration of your drive.

9.4 Fault and Warning Messages

When a fault occurs, the drive fault relay is opened, the output stage is switched off (motor loses all torque), or the load is dynamically braked. The specific drive behavior depends on the type of fault. The LED display on the front panel of the drive shows the number of the fault that occurred. If a warning is issued prior to the fault, the warning is shown on the LED and has the same number as the associated fault. Warnings do not trip the power stage of the drive or fault relay output.

The left side of the LED displays F for a fault or n for a warning. The right side displays the fault or warning number as follows: 1-0-1-[break]. The highest priority fault is displayed on the LED. Multiple faults may be present when a fault condition is occurring. Check the AKDWorkBench Fault Screen or read the status of DRV.FAULTS through the controller or HMI for the entire list of faults.

NOTE

More information about fault messages and clearing faults can be found in the WorkBench online help. Procedures for clearing faults are described in the online help topic entitled "Faults and Warnings".

Fault	Message/Warning	Cause	Remedy
0		Reserved.	N/A
101	Firmware incompatible. Warning issued prior to fault.	Installed firmware is not compatible with the drive hardware.	Load compatible firmware into the drive.
102	Resident firmware failed. Warning issued prior to fault.	Software failure detected.	Restart drive. If issue persists, contact technical support.
103	Resident FPGA failed.	Software failure detected. Load resident FPGA failure occurred (several cases according to flowchart, including incompatible image to FPGA type and fieldbus type).	Restart drive. If issue persists, contact technical support.
104	Operational FPGA failed.	Software failure detected. Load operational FPGA failure occurred (several cases according to flowchart).	Restart drive. If issue persists, contact technical support.
105	NV memory stamp invalid.	NV memory stamp is corrupted or invalid.	Reset the drive to default memory values using Parameter Load in WorkBench.
106	NV memory data (might occur when downloading firmware).	NV memory data is corrupted or invalid. This fault often occurs when downloading firmware.	Reset the drive to default memory values using Parameter Load in WorkBench.
107	Positive switch limit exceeded. Warning issued prior to fault.	Positive software position limit is exceeded.	Move the load away from the limits.
108	Negative switch limit exceeded. Warning issued prior to fault.	Negative software position limit is exceeded.	Move the load away from the limits.
121	Homing error.	Drive did not finish homing sequence.	Check homing sensor.
123	Invalid motion task. Warning issued prior to fault.	Invalid motion task.	Check motion task settings and parameters to make sure that the values entered will produce a valid motion task. Refer to the motion task documentation for additional guidance on specific causes of invalid motion tasks.

Fault	Message/Warning	Cause	Remedy
125	Synchronization lost. Warning issued prior to fault.	The fieldbus lost synchronization.	Check fieldbus connection (X5 and X6 if you are using EtherCAT; X12 and X13 if you are using CANopen) or the settings of your EtherCAT or CANopen master.
126	Too much movement. Warning issued prior to fault.	Too much movement was created during a Bode plot. Motor is unstable and is not following drive instructions.	Check that the system is closed loop stable. Refer to the system tuning guide.
127	Incomplete emergency stop procedure.	Incomplete emergency stop procedure (problem with the emergency stop motion task).	Disconnect power from drive and check emergency stop procedure.
128	MPOLES/FPOLES not an integer.	Ratio of motor poles to feedback poles must be a whole number.	Change to a compatible feedback device.
129	Heartbeat lost.	Heartbeat lost.	Check CANopen cabling. Reduce bus load or increase the heartbeat update time.
130	Secondary feedback supply over current.	Problem in secondary feedback detected.	Check X9 connection.
131	Emulated encoder line break.	Problem in secondary feedback detected.	Check secondary feedback (X9 connection).
132	Emulated encoder Z break.	Problem in secondary feedback detected.	Check secondary feedback (X9 connection).
133	Instability during Autotune	Drive current (IL.CMD) or velocity feedback (VL.FB) exceeds allowable limit (BODE.IFLIMIT or BODE.VFLIMIT). This fault only occurs in BODE.MODE 5, which uses a stability checking algorithm. This fault often occurs when complex mechanics, belts, and compliant loads are present, which make accurate measurement hard to obtain with the PST settings.	Change BODE.MODE if appropriate. If BODE.MODE 5 is appropriate and the fault occurs at the end of an Autotuning, then the motor is not robustly stable. You can manually adjust Autotuner settings to increase FFT point resolution, record points, and current excitation. Manual tuning may be required to make the motor stable.
134	Secondary feedback illegal state.	Problem in secondary feedback detected.	Check X9 connection.
135	Homing is needed. Warning issued prior to fault.	Attempt to issue motion task before the axis is homed. Axis must be homed before motion task can start.	Change opmode or home axis.
201	Internal RAM failed.	Hardware failure detected.	Restart drive. If issue persists, contact technical support.
202	External RAM failed.	Hardware failure detected.	Restart drive. If issue persists, contact technical support.
203	Code integrity failed.	Software failure detected. FPGA register access failure occurred.	Restart drive. If issue persists, contact technical support.
204 to 232	EEPROM failure detected	EEPROM failure detected	Restart drive. If issue persists, exchange drive.
234 to 237	Temperature sensor high. Warning issued prior to fault.	High temperature limit reached.	Check cabinet ventilation system.

Fault	Message/Warning	Cause	Remedy
240 to 243	Temperature sensor low. Warning issued prior to fault.	Low temperature limit reached.	Check cabinet ventilation system.
245	External fault.	This fault is user generated and is caused by user settings.	Users can configure a digital input to trigger this fault (DINx.MODE = 10). The fault occurs according to this input setting. Clear the input to clear the fault.
247	Bus voltage exceed allowed thresholds.	Hardware problem in bus measurement.	Troubleshoot and repair hardware problem.
301	Motor overheated. Warning issued prior to fault.	Motor overheated.	Check ambient temperature. Check motor mounting heat sink capability
302	Over speed.	Motor exceeded VL.THRESH value.	Look for overshoot or lower requested speed.
303	Runaway.	Motor did not follow command values.	Gains are too low; motor is being over driven.
304	Motor foldback. Warning issued prior to fault.	Maximum motor power has been exceeded; the power has been limited to protect the motor	Motion is requiring too much power. Change move profile to reduce load on motor. Check for load jamming or sticking. Check that current limits are set correctly.
305	Brake open circuit.	Motor brake open circuit.	Check cabling and general functionality.
306	Brake short circuit.	Motor brake short circuit.	Check cabling and general functionality.
307	Brake closed during enable state.	Motor brake closed unexpectedly.	Check cabling and general functionality.
308	Voltage exceeds motor rating.	Drive bus voltage exceeds the motor's defined voltage rating.	Make sure that the motor fits the driving rating.
401	Failed to set feedback type.	Feedback is not connected or wrong feedback type selected	Check primary feedback (X10 connection).
402	Analog signal amplitude fault.	Analog signal amplitude is too low. Analog fault (resolver signal amplitude or sin/cos amplitude)	Check primary feedback (X10 connection), resolver and sine/cos encoder only.
403	EnDat communication fault.	General communication problem with feedback.	Check primary feedback (X10 connection), EnDat only
404	Hall error.	Hall sensor returns invalid Hall state (111, 000); either all Hall sensors are on or off. Legal Hall states are 001, 011, 010, 110, 100, and 101. This fault can be caused by a broken connection in any one of the Hall signals.	Check the feedback wiring; check all feedback connectors to ensure all pins are positioned correctly.
405	BiSS watchdog fault.	Bad communication with the feedback device.	Check primary feedback (X10 connection), Biss only.

Fault	Message/Warning	Cause	Remedy
406	BiSS multicycle fault.	Check primary feedback (X10 connection), Biss only.	
407	BiSS sensor fault.	Check primary feedback (X10 connection), Biss only.	
408 to 416	SFD Feedback Fault	Bad communication with the SFD device.	Check primary feedback (X10 connection). If fault persists, internal feedback failure. Return to manufacturer for repair.
417	Broken wire in primary feedback.	In primary feedback, a broken wire was detected (incremental encoder signal amplitude).	Check feedback cable continuity.
418	Primary feedback power supply.	Power supply fault for primary feedback.	Check primary feedback (X10 connection).
419	Encoder init procedure failed	Phase find procedure did not complete successfully.	Check encoder wiring, reduce/balance motor load prior to phase finding.
424	Resolver amplitude low.	Resolver signal amplitude is below minimum level.	Check primary feedback (X10 connection).
425	Resolver amplitude high.	Resolver signal amplitude is above maximum level.	Check primary feedback (X10 connection).
426	Resolver error.	Resolver excitation fault.	Check primary feedback (X10 connection).
427	Analog low.	Analog signal amplitude low.	Check primary feedback (X10 connection).
428	Analog high.	Analog signal amplitude high.	Check primary feedback (X10 connection).
429	Incremental low.	Incremental encoder signal amplitude is below minimum level.	Check primary feedback (X10 connection).
430	Incremental high.	Incremental encoder signal amplitude is above maximum level.	Check primary feedback (X10 connection).
431	Secondary feedback Hall error.	Secondary feedback illegal Hall state (000,111).	Check X9 connection.
432	Communication fault.	General communication problem with secondary feedback.	Check secondary feedback (X10 connection).
437	Close to limit.	Drive or motor over current or over speed warning.	Check for increased load, jamming or sticking. Is position error set too low?
438	Following error (numeric) Warning issued prior to fault.	Motor did not follow command values. Motor exceeded maximum allowed position following error (numeric).	Check for increased load, jamming or sticking. Is position error set too low?
439	Following error (user). Warning issued prior to fault.	Motor did not follow command values. Motor exceeded maximum allowed position following error (user).	Check feedback commutation setup and tuning parameters.
450	Following error (presentation).	Motor did not follow command values. Motor exceeded maximum allowed position following error (presentation).	Check feedback commutation setup and tuning parameters.
473	Wake and Shake. Insufficient movement	There was less movement than defined by WS.DISTMIN.	Increase WS.IMAX and/or WS.T
475	Wake and Shake. Excess movement.	WS.DISTMAX has been exceeded.	Increase WS.DISTMAX value or reduce WS.IMAX or WS.T.

Fault	Message/Warning	Cause	Remedy
476	Wake and Shake. Fine-coarse delta too large.	The angle difference between the coarse and fine calculation was larger than 72 deg.	Modify WS.IMAX or WS.T and try again.
478	Wake and Shake. Over-speed. Warning issued prior to fault.	WS.VTHRESH was exceeded.	Increase WS.VTHRESH value or reduce WS.IMAX or WS.T.
479	Wake and Shake. Loop angle delta too large. Warning issued prior to fault.	The angle between complete loops was larger than 72 deg.	Modify WS.IMAX or WS.T and try again.
501	Bus over voltage. Warning issued prior to fault.	Bus voltage too high. Usually, this problem is load related.	Reduce load or change motion profile. Check system regen capacity; add capacity if needed. Check mains voltage.
502	Bus under voltage. Warning issued prior to fault.	Bus voltage below threshold value.	Check mains voltage.
503	Bus capacitor overload. Warning issued prior to fault.	Single phase AC input on a drive only rated for three-phase input or excessive single-phase power load.	Check mains voltage.
504 to 518	Internal supply voltage fault	Internal supply voltage fault detected	Check wiring for electromagnetic compatibility (EMC). If issue persists exchange drive.
519	Regen short circuit.	Regen resistor short circuit.	Regen IGBT short circuit. Contact technical support.
520	Regen overload.	Regen resistor overload.	Motor is being overhauled or motor is being stopped too quickly.
521	Regen over power. Warning issued prior to fault.	Too much power stored in regen resistor.	Increase regen resistor capacity. Either get larger brake resistor or use DC bus sharing to dissipate power..
523	Bus over voltage FPGA	Bus over voltage hard fault.	Check mains voltage and check system brake capacity.
524	Drive foldback. Warning issued prior to fault.	Maximum drive power has been exceeded. The power has been limited to protect the drive.	Motion requires too much power. Change profile to reduce load .
525	Output over current.	Current exceeds drive peak.	Check for short or feedback faults.
526	Current sensor short circuit.	Current sensor short circuit.	Restart drive. If issue persists, contact technical support.
527	Iu current AD converter stuck.	Hardware failure detected.	Restart drive. If issue persists, contact technical support.
528	Iv current AD converter stuck.	Hardware failure detected.	Restart drive. If issue persists, contact technical support.
529	Iu current offset limit exceeded.	Hardware failure detected.	Restart drive. If issue persists, contact technical support.
530	Iv current offset limit exceeded.	Hardware failure detected.	Restart drive. If issue persists, contact technical support.

Fault	Message/Warning	Cause	Remedy
531	Power stage fault.	Hardware failure detected.	Restart drive. If issue persists, replace drive.
532	Drive motor parameters setup incomplete.	Before a motor can be enabled, you must configure a minimum set of parameters. These parameters have not been configured.	Issue the command <code>DRV.SETUPREQLIST</code> to display the list of the parameters that you must configure. Configure these parameters either manually or automatically. You can manually configure these parameters in three ways: (1) set each parameter individually; (2) use the setup wizard to select the motor; or (3) select the motor type from the motor data base in the Motor window (<code>MOTOR.AUTOSSET</code> must be set to 0 (FALSE)). If you use the Motor window, you must first select the feedback type. If the motor has Biss Analog, Endat, or SFD feedback (feedback with memory), then these parameters are set automatically when <code>MOTOR.AUTOSSET</code> is set to 1 (TRUE).
534	Failed to read motor parameters from feedback device.	Motor either does not have motor feedback memory, or the motor feedback memory is not programmed properly so the parameters cannot be read.	Try to read parameters again by clicking the Disable and Clear Faults button, or by issuing the <code>DRV.CLRFAULTS</code> command. If this attempt is not successful, then set <code>MOTOR.AUTOSSET</code> to 0 (false) and program the parameters using the setup wizard or manually set up the parameters. If the motor has motor memory (Biss Analog, Endat, and SFD motors have motor memory), return the motor to have the memory programmed.
602	Safe torque off.	Safe torque off function has been triggered.	Reapply supply voltage to STO if safe to do so.
701	Fieldbus runtime.	Runtime communication fault.	Check fieldbus connections (X11), settings, and control unit.
702	Fieldbus communication lost. Warning issued prior to fault.	All fieldbus communication was lost.	Check fieldbus connections (X11), settings, and control unit.
703	Emergency timeout occurred while axis should disable	Motor did not stop in the timeout defined.	Change timeout value, change stop parameters, improve tuning.

9.5 Troubleshooting the AKD

Faults occur for a variety of reasons, depending on the conditions in your installation. The causes of faults in multi-axis systems can be especially complex. If you cannot resolve a fault using the troubleshooting guidance presented below, customer support can give you further assistance.

NOTE More details on the removal of faults can be found in the online help and in the fault and warning messages table "Fault and Warning Messages" (=> p. 133) .

Fault	Possible Causes	Remedy
HMI message: Communication fault	<ul style="list-style-type: none"> — wrong cable used — cable plugged into wrong position on servo amplifier or PC — wrong PC interface selected 	<ul style="list-style-type: none"> — plug cable into the correct sockets on the servo amplifier and PC — select correct interface
Motor does not rotate	<ul style="list-style-type: none"> — servo amplifier not enabled — software enable not set — break in setpoint cable — motor phases swapped — brake not released — drive is mechanically blocked — motor pole no. set incorrectly — feedback set up incorrectly 	<ul style="list-style-type: none"> — apply ENABLE signal — set software enable — check setpoint cable — correct motor phase sequence — check brake control — check mechanism — set motor pole no. — set up feedback correctly
Motor oscillates	<ul style="list-style-type: none"> — gain is too high (speed controller) — feedback cable shielding broken — AGND not wired up 	<ul style="list-style-type: none"> — reduce VL.KP (speed controller) — replace feedback cable — join AGND to CNC-GND
Drive reports following error	<ul style="list-style-type: none"> — Irms or Ipeak set too low — current or velocity limits apply — accel/decel ramp is too long 	<ul style="list-style-type: none"> — verify motor/drive sizing — verify that IL.LIMITN, IL.LIMITP, VL.LIMITN, or VL.LIMITP is not limiting the drive — reduce DRV.ACC/DRV.DEC
Motor overheating	<ul style="list-style-type: none"> — motor operating above its rating 	<ul style="list-style-type: none"> — verify motor/drive sizing — verify motor continuous and peak current values are set correctly
Drive too soft	<ul style="list-style-type: none"> — Kp (speed controller) too low — Ki (speed controller) too low — filters set too high 	<ul style="list-style-type: none"> — increase VL.KP (speed controller) — increase VL.KI (speed controller) — refer to documentation regarding reducing filtering (VL.AR*)
Drive runs roughly	<ul style="list-style-type: none"> — Kp (speed controller) too high — Ki (speed controller) too high — filters set too low 	<ul style="list-style-type: none"> — reduce VL.KP (speed controller) — reduce VL.KI (speed controller) — refer to documentation regarding increasing filtering (VL.AR*)

10 Option Cards

Option cards will be available in future drives.

11 Order Codes

11.1 Cables, brake resistors, filters, chokes

The order numbers for accessories such as cables, brake resistors, and mains supplies are included in the accessories manual (available on the CDROM or website).

11.2 Drives

The part number scheme (=> p. 29) determines the order number.

11.3 Mating connectors

11.3.1 AKD-xzzz06

Item	AKD-06 Current Types	Order Code
Mating connector X1	All	CON-AKDX1-SL
Mating connector X2	03 to 06	CON-AKDX2A-SL
	12/24	CON-AKDX2B-SL
Mating connector X3	03 to 06	CON-AKDX3A-SL
	12	CON-AKDX3B-SL
	24	CON-AKDX3C-SL
Mating connector X4	24	CON-AKDX4-SL
Mating connector X7	All	CON-AKDX7-SL
Mating connector X8	All	CON-AKDX8-SL

11.3.2 AKD-xzzz07

Item	AKD-07 Current Types	Order Code
Mating connector X1	All	CON-AKDX1-SL
Mating connector X2	All	CON-AKDX2B-SL
Mating connector X3	All	CON-AKDX3C-SL
Mating connector X4	All	CON-AKDX4-SL
Mating connector X7	All	CON-AKDX7-SL
Mating connector X8	All	CON-AKDX8-SL

This page intentionally left blank.

12 Index

A

Abbreviations	11
AKD Family	31
Ambient temperature	33
Analog inputs	111
Analog setpoints	111
Assembly	62
Aux. supply 24V, interface	86

B

Basic Drive Test	130
BISS encoder	98
Brake circuit	41
Brake resistor, interface	89

C

Cable and Wire Requirements	39
CANbus	
Baud rate	120
Cable	121
CANopen interface	120
Node address	121
Termination	121
CE conformance	20
Comcoder interface	103
Connection diagram	
AKD-x00306 to x00606	77
AKD-x01206	78
AKD-x01206 & AKD-xzzz07	79
Connector assignments	
AKDx00306 to AKDx00606	75
AKDx01206	75
AKDx02406	76
Connectors	38

D

DC Bus Capacitance	42
DC bus link, interface	90
Dig. Encoder emulation, interface	107
Digital inputs	113
Dimensions	
AKDx00306 to 00606	64
AKDx00307 to 00607	67
AKDx01206	65
AKDx02406	66
AKDx02407	68
Disposal	26
Dynamic Braking	41

E

EC Declaration of Conformity	22
Emergency Stop Function	51
Emulated Encoder Connector	104
Emulated Encoder Output	107
ENABLE	115
Enclosure protection	33
EnDat 2.1 encoder interface	99
EnDat 2.2 encoder interface	100
EtherNet	
EtherCAT Protocol	124
Ethernet IP Protocol	124
Modbus TCP/IP	124
Powerlink Protocol	124
ProfiNet NR Protocol	124
SERCOS III Protocol	124
SynqNet Protocol	124

F

Fault messages	133
FAULT relay	117
Feedback	94
Feedback Connection	95
Fusing	37

G

Grounding	71
Grounding Plates	83

H

Hardware requirements	128
Hiperface encoder interface	101
Humidity	
in operation	33
Storage	25
Transport	25

I

I/O-Connection	110
Inputs	
Analog	111
Basic Data	33
Digital	113
Enable	115
Programmable	115
STO	53
Installation	
Electrical	69
Mechanical	61
Software	129

L			
Leakage current	59		
M			
Mains supply, interface	87		
Maintenance	26		
Master-slave	104		
Master-Slave	109		
Motor-holding brake	93		
Motor interface	91		
Motor Power Connection	92		
Mounting position	33		
N			
Nameplate	28		
Noise Emission	33		
O			
Operating systems	128		
Option Cards	140		
Order codes	141		
Outputs			
Analog	112		
Basic Data	33		
Digital	116		
Fault	117		
P			
Package supplied	28		
Packaging	25		
Part number scheme	29		
PC connection	118		
Pollution level	33		
Prohibited Use			
General	16		
STO	54		
Pulse Direction, interface	108		
R			
Re-forming	126		
Repair	26		
Resolver interface	96		
ROD 5V with Hall interface	103		
Rotary Switches	119		
RS232/PC, interface	118		
S			
Safety Instructions			
Electrical Installation	70		
General	15		
		Mechanical Installation	61
		Setup	126
		STO	54
		Setup	126
		Setup Software	127
		SFD	97
		Shield connection	81
		Shielding	71
		Shock-hazard protection	59
		SinCos encoder with Hall	102
		Site	61
		Site altitude	33
		Stacking height	25
		Stacking Height, Storage	25
		Standards	21
		Standards used	13
		STO	53
		Stop Function	51
		Storage	25
		Supply networks	84
		Switch-on/switch-off behavior	44
		Symbols used	12
		System components, overview	73
		T	
		Target group	10
		Temperature	
		in operation	33
		Storage	25
		Transport	25
		Tightening torques, connectors	36
		Transport	25
		Trouble Shooting	139
		U	
		UL Markings	18
		Uninstalling	26
		Up/Down Input	109
		Use as directed	
		Drive	16
		Setup Software	127
		STO	54
		V	
		Ventilation	
		Ambient Conditions	33
		Mechanical Installation	61
		Vibrations	33
		W	
		Warnings	133
		Wiring	72

This page intentionally left blank.

Sales and Service

We are committed to quality customer service. In order to serve in the most effective way, please contact your local sales representative for assistance.

If you are unaware of your local sales representative, please contact us.

Europe

Kollmorgen Customer Support Europe

Internet www.kollmorgen.com
E-Mail technik@kollmorgen.com
Tel.: +49(0)2102 - 9394 - 0
Fax: +49(0)2102 - 9394 - 3110

North America

Kollmorgen Customer Support North America

Internet www.kollmorgen.com
E-Mail support@kollmorgen.com
Tel.: +1 - 540 - 633 - 3545
Fax: +1 - 540 - 639 - 4162

KOLLMORGEN®
