

# AKME Hazardous Location Servo Motor

Three-Phase AC Permanent Magnet Servo Motor

English



Installation Manual

中文



安装手册



Edition: A, April 2026

Part Number: FP00945

Original Language is English. All other content is translated from the genuine English content.



For safe and proper use, follow these instructions.  
Keep for future use.



**KOLLMORGEN**

A REGAL REYNOLD BRAND

### Record of Document Revisions

Revision	Date	Remarks
A	March 2026	First English edition.

### Table of Contents



"English" (→ p. 3)

"Approvals" (→ p. 144)



"中文" (→ p. 39)

# 1 English

---

<b>1.1 About this Manual</b> .....	<b>5</b>
1.1.1 Symbols Used .....	6
1.1.2 Abbreviations Used .....	6
<b>1.2 Part Number Scheme</b> .....	<b>7</b>
<b>1.3 Safety</b> .....	<b>8</b>
1.3.1 Specialist Staff Required! .....	8
1.3.2 Read the Documentation! .....	8
1.3.3 Pay Attention to the Technical Data! .....	8
1.3.4 Perform a Risk Assessment! .....	8
1.3.5 Secure the Key! .....	9
1.3.6 Transport Safely! .....	9
1.3.7 Safety Warnings .....	9
1.3.8 Use as Directed .....	10
1.3.9 ATEX Specific Conditions of Use .....	11
1.3.10 Prohibited Use .....	11
<b>1.4 Product Life Cycle Handling</b> .....	<b>12</b>
1.4.1 Maintenance and Cleaning .....	13
1.4.2 Packaging .....	13
1.4.3 Repair and Disposal .....	14
1.4.4 Storage .....	14
1.4.5 Transport .....	15
<b>1.5 Package</b> .....	<b>16</b>
1.5.1 Package Supplied .....	16
1.5.2 Nameplate .....	16
<b>1.6 General Technical Data</b> .....	<b>17</b>
<b>1.7 Standard Features</b> .....	<b>18</b>
1.7.1 Feedback .....	19
1.7.2 Flange .....	20
1.7.3 Grounding Bolt .....	20
1.7.4 Holding Brake .....	21
1.7.5 Ingress Protection Class .....	23
1.7.6 Insulation Material Class .....	23
1.7.7 Shaft End, A-side .....	23

---

1.7.8 Shaft Seal .....	24
1.7.9 Style .....	24
1.7.10 Surface .....	24
1.7.11 Thermal Protective Device .....	25
1.7.12 Vibration Class .....	25
<b>1.8 Wiring Technology .....</b>	<b>26</b>
1.8.1 Connectors .....	26
1.8.2 Cable Mating Connector Part Numbers .....	26
1.8.3 Wire Cross Sections .....	27
<b>1.9 Mechanical Installation .....</b>	<b>28</b>
1.9.1 Installation and Operating Conditions .....	28
1.9.2 Flange Mounting .....	28
<b>1.10 Electrical Installation .....</b>	<b>30</b>
1.10.1 Electrical Installation Guide .....	31
1.10.2 Connect the Servo Motor with Pre-assembled Cables .....	31
<b>1.11 Setup .....</b>	<b>32</b>
1.11.1 Setup Procedure .....	33
<b>1.12 Troubleshooting .....</b>	<b>34</b>
1.12.1 Brake Does Not Engage .....	35
1.12.2 Error Message: Output Stage Fault .....	35
1.12.3 Error Message: Resolver .....	35
1.12.4 Error Message: Servo Motor Brake .....	35
1.12.5 Error Message: Servo Motor Temperature .....	35
1.12.6 Servo Motor does not Rotate .....	36
1.12.7 Servo Motor Oscillates .....	36
1.12.8 Servo Motor Runs Away .....	36
<b>1.13 Technical Data Terminology .....</b>	<b>37</b>

## 1.1 About this Manual

This manual describes the AKME series of ATEX explosion-proof servo motors.

The servo motors are operated in drive systems together with Kollmorgen servo drives.











Read all this system documentation:

- Instruction manual for the servo drive.
- Bus Communication manual (e.g., CANopen or EtherCAT®).
- Online help of the servo drive's setup software.
- Regional accessories manual.
- Technical description of the AKME series of servo motors.
- More background information is available from the [Kollmorgen Support Network](#).

### NOTE

Contact Kollmorgen customer support for a printed copy of the installation manual.

### 1.1.1 Symbols Used

Symbol	Indication
	Indicates a hazardous situation which, if not avoided, <b>will result in death or serious injury</b> .
	Indicates a hazardous situation which, if not avoided, <b>could result in death or serious injury</b> .
	Indicates a hazardous situation which, if not avoided, could result in minor or moderate injury.
	Indicates situations which, if not avoided, could result in property damage.
	Indicates useful information.
	Indicates specific information that could impact results.
	Indicates helpful information for ease-of-use with the device, software, or firmware.
	Warning of a danger (general). The type of danger is specified by the text next to the symbol.
	Warning of danger from electricity and its effects.
	Warning of danger from hot surface.
	Warning of danger from suspended loads.

### 1.1.2 Abbreviations Used

See "Technical Data Terminology" (→ p. 37).

**NOTE**

In this document, the symbol (→ p. 53) means: see page 53.

## 1.2 Part Number Scheme

**! IMPORTANT**

- The part number scheme is for product identification only.
- Do not use for the order process because not all combinations of features are possible.

**AKME 5 3 G - A C 9 2 CB 01**

AKME Series

Flange Size

- 2 58 mm
- 3 70 mm
- 4 84 mm
- 5 108 mm
- 6 138 mm
- 7 188 mm

Rotor Stack Length

**AKMEx Availability**

		2	3	4	5	6	7
1	1 stack	•	•	•	•		
2	2 stacks	•	•	•	•	•	•
3	3 stacks	•	•	•	•	•	•
4	4 stacks	•		•	•	•	•
5	5 stacks					•	

Winding Type

B C D E F G H J K L M N P Q

Mount

- A IEC with tolerance N
- B NEMA
- C Alternative IEC standard
- D Other standard
- E NEMA mount
- G Alternative IEC standard
- H Alternative IEC standard
- K Alternative NEMA mount
- L NEMA mount
- S Special

Shaft

- C Keyway
- K Open keyway
- N Smooth shaft
- S Special

Customization/Seal

- 01 ATEX Standard motor with shaft seal
- 0X ATEX Customized motor

Feedback Device

**Hybrid Single-Cable Options**

- CB SFD-M (AKME 2-6)
- GU HIPERFACE DSL ■ Safety Capable (AKME 2-6)

**Dual-Cable Options**

- 2- Comcoder 2048 Lines (AKME 2-7)
- AA BiSS B Single-turn (AKME 2-7)
- AB BiSS B Multi-turn (AKME 2-7)
- DA EnDAT 2.2/01 Single-turn (AKME 2-7)
- DB EnDAT 2.2/01 Multi-turn (AKME 2-7)
- GJ HIPERFACE Single-turn (AKME 2-7)
- GK HIPERFACE Multi-turn (AKME 2-7)
- R- Resolver (AKME 2-7)
- S- Special

Brake

- 2 24 V holding brake
- N Without brake

Connectors

- 4 Dual 90° M23 connectors, motor-mounted (AKME 2-7, except AKME7 > 20 A)
- 9 Single 90° hybrid connector, motor-mounted (AKME2-6)
- W Dual 90° M40 connector and M23 feedback connector, motor-mounted (AKME7 > 20 A)

Base Model	Mount-Shaft Availability																				
	AC	AK	AN	BK	BN	CC	CK	CN	DC	DK	DN	EF	EK	EN	GC	GN	HC	HN	KK	LK	
AKME2	•		•			•		•		•		•		•							
AKME3	•		•			•		•							•	•					
AKME4	•		•	•		•		•					•		•	•	•	•	•		
AKME5	•		•	•		•		•		•			•		•	•	•	•	•		
AKME6	•		•												•	•				•	•
AKME7	•		•												•	•				•	•

## 1.3 Safety

### 1.3.1 Specialist Staff Required!



Only properly qualified personnel are permitted to perform such tasks as transport, assembly, setup, and maintenance.

Qualified specialist staff are people familiar with the transport, installation, assembly, commissioning, and operation of servo motors and who use their relevant minimum qualifications in their duties.

- Electrical Installation: Only by electrical engineering qualified personnel.
- Mechanical Installation: Only by mechanically qualified personnel.
- Setup: Only by qualified personnel with extensive knowledge of electrical engineering and drive technology.
- Transport: Only by personnel with knowledge of handling electrostatically sensitive components.

The qualified personnel must know and observe IEC 60364 / IEC 60664 and national accident prevention regulations.

### 1.3.2 Read the Documentation!



Read the available documentation before installation and commissioning.

- Improper handling of the can cause harm to people or damage to property.
- Strictly adhere to the technical information on the installation requirements.
- The operator must ensure that all persons entrusted to work on the servo motor have read and understood the manual and that the safety notices in this manual are observed.

### 1.3.3 Pay Attention to the Technical Data!



- Adhere to the technical data and the specifications on connection conditions (rating plate and documentation).
- If permissible voltage values or current values are exceeded, the servo motors can be damaged (e.g., by overheating).

### 1.3.4 Perform a Risk Assessment!



The manufacturer of the machine must:

- Generate a risk assessment for the machine.
- Take appropriate measures to ensure that unforeseen movements cannot cause injury or damage to any person or property.
- Specialist staff may have additional requirements as a result of the risk assessment.

### 1.3.5 Secure the Key!



- Remove any fitted key (if present) from the shaft before letting the servo motor run without coupled load to avoid the dangerous results of the key being thrown out by centrifugal forces.
- When delivered, the key is protected with a plastic cap.

### 1.3.6 Transport Safely!



- Lift and move servo motors that weigh more than 20kg (e.g., AKME6 and AKME7) only with lifting tools.
- Lifting unassisted could result in back injury.
- Always observe the information in "Transport" (→ p. 15).

### 1.3.7 Safety Warnings

Symbol	Description
	<p><b>Hot surface!</b></p> <p>The surfaces of the servo motors can be very hot in operation, according to their protection category.</p> <ul style="list-style-type: none"> <li>• Risk of minor burns!</li> <li>• The surface temperature can exceed 100 °C.</li> <li>• Measure the temperature and wait until the servo motor has cooled down below 40 °C before touching it.</li> </ul>
	<p><b>Earthing! High voltages!</b></p> <p>It is vital that you ensure the servo motor housing is safely earthed to the PE (protective earth) busbar in the switch cabinet.</p> <ul style="list-style-type: none"> <li>• Risk of electric shock!                             <ul style="list-style-type: none"> <li>• Without low-resistance earthing, no personal protection can be guaranteed and there is a risk of death from electric shock.</li> </ul> </li> <li>• Not having optical displays does not guarantee an absence of voltage.                             <ul style="list-style-type: none"> <li>• Power connections may carry voltage even if the servo motor shaft is not rotating.</li> </ul> </li> <li>• Do not unplug any connectors during operation.                             <ul style="list-style-type: none"> <li>• There is a risk of death or severe injury from touching exposed contacts.</li> <li>• Power connections may be live even when the servo motor shaft is not rotating.</li> <li>• This can cause flashovers with resulting injuries to persons and damage to the contacts.</li> </ul> </li> <li>• After disconnecting the servo drive from the supply voltage, wait several minutes before touching any components which are normally live (e.g., contacts, screw connections) or opening any connections.</li> <li>• The capacitors in the servo drive can still carry a dangerous voltage several minutes after switching off the supply voltages.                             <ul style="list-style-type: none"> <li>• To be safe, measure the DC-link voltage and wait until the voltage has fallen below 60V<sub>DC</sub>.</li> </ul> </li> </ul>
	<p><b>Secure hanging loads!</b></p> <ul style="list-style-type: none"> <li>• Built-in holding brakes do not ensure functional safety!</li> <li>• Hanging loads (vertical axes) require an additional, external mechanical brake to ensure personnel safety.</li> </ul>

### 1.3.8 Use as Directed

- The AKME series of synchronous servo motors is designed especially for drives for industrial robots, machine tools, textile and packing machinery, and similar with high requirements for dynamics.
- The thermal sensor integrated in the servo motor windings must be observed and evaluated.
- The user is only permitted to operate the servo motors under the ambient conditions defined in this documentation.
- The AKME series of servo motors is **exclusively** intended to be driven by servo drives under speed and / or torque control.
- The servo motors are installed as components in electrical apparatus or machines and can only be commissioned and put into operation as integral components of such apparatus or machines.
- The holding brakes are designed as standstill brakes and are not suited for repeated operational braking.
- The conformity of the servo system to the standards mentioned in the EC Declaration of Conformity is only guaranteed when the components (servo drives, servo motors, cables, etc.) that are used have been supplied by Kollmorgen.
  - See "Approvals" (→ p. 144).

#### NOTE

1. Wire the PE connections immediately after installing the devices as the first electrical connection.
2. Insert all other lines and connectors.
3. For disassembly, release the PE connections as the last connection.

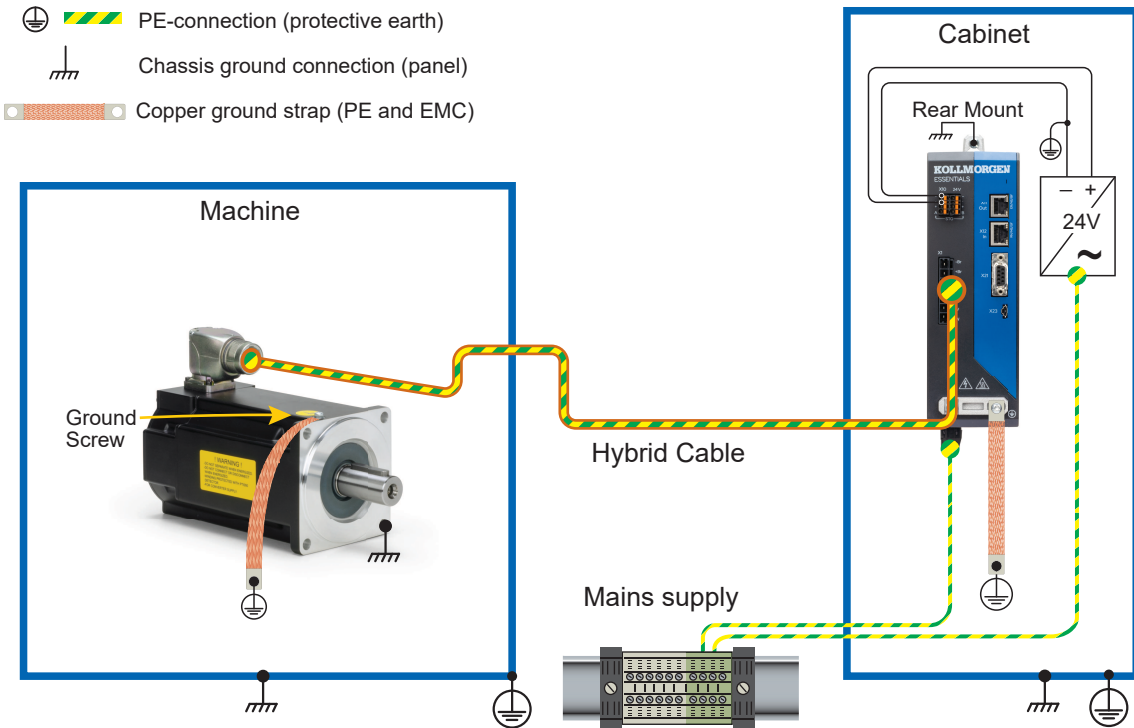

### 1.3.9 ATEX Specific Conditions of Use

- The servo motor must be used with the drive as specified in the manufacturer's user manual.
  - This must comply with the servo motor electrical specifications and operating characteristics.
  - The frequency converter must be chosen according to the parameters specified in this certificate.
  - The maximum allowable short-circuit current through the drive is 300A.
- The performance data of the explosion proof motor must be used within the limits set by the technical data provided in the Certificate of Conformity Annex.
- The connectors are tested with the servo motor to ensure ingress protection of IEC 60079-0 completely.
  - For the AKME2 to AKME7 series, the mating connectors and cable must be chosen according to the type specified in the user manual.
- Brakes are intended to be used only as a parking device.
- Each servo motor shall be equipped with a thermal protector connected to the servo motor control circuit in such a manner as to disconnect the source of supply to prevent exceeding the specified temperature class.
- For installation in Zone 2 hazardous area:
  - Transient protection shall be provided that is set at a level not exceeding 140% of the peak rated voltage value at the supply terminals to the equipment (see Annex H.5 of IEC 60079-7).
  - The equipment is intended to be installed in environments with a pollution level that shall be limited to pollution degree 2 or better, as defined in IEC 60664-1 (see Annex H.3 of IEC 60079-7).

### 1.3.10 Prohibited Use

- The use of the servo motors is prohibited directly on supply networks, mains.
- The use of the servo motors is prohibited in:
  - contact with food and beverage.
  - environments with caustic and/or electrically conducting acids, bases, oils, vapors, dusts.
- Do not operate the servo motor in a hazardous location with any securing screws or covers removed.
- Do not remove any screws or covers while the servo motor is in a hazardous location.
- Commissioning the servo motor is prohibited if the machine in which it was installed:
  - Does not meet the requirements of the EC Machinery Directive.
  - Does not comply with the EMC Directive.
  - Does not comply with the Low Voltage Directive.
- Built-in holding brakes without further equipment must not be used to ensure functional safety.

## 1.4 Product Life Cycle Handling

---

1.4.1 Maintenance and Cleaning .....	13
1.4.2 Packaging .....	13
1.4.3 Repair and Disposal .....	14
1.4.4 Storage .....	14
1.4.5 Transport .....	15

### 1.4.1 Maintenance and Cleaning

#### NOTICE

- Maintenance and cleaning must be done by qualified personnel only.
- Opening the servo motor voids the warranty.
- Once per year or after 2,500 hours of operation:
  - Check the servo motor for bearing noise.
    - If any unusual noises are heard, stop the operation of the servo motor.
    - The bearings must be replaced by the manufacturer.
- After 20,000 hours of operation under rated conditions, ball bearings should be replaced by the manufacturer.
- If the housing is dirty, clean the housing with Isopropanol or similar.
  - Do **not** immerse or spray.

### 1.4.2 Packaging

- Cardboard packing with Instapak™ foam cushion.
  - Recycling of foam is possible at special waste collection points.
- You can return the plastic portion to the supplier.
  - See "Repair and Disposal" (→ p. 14).

Servo Motor Type	Packaging	Maximum Stacking Height
AKME2	Cardboard	10
AKME3	Cardboard	6
AKME4	Cardboard	6
AKME5	Cardboard	5
AKME6	Cardboard	1
AKME7	Cardboard	1

### 1.4.3 Repair and Disposal

#### 1.4.3.1 Repair

Repair of the servo motor must be done by the manufacturer.

- Opening the servo motor voids the warranty.
- The manufacturer accepts returns of old servo motors and accessories for professional disposal.
  - This is in accordance to the WEEE-2012/19/EU Guidelines.
- The sender is responsible for the transport costs to return the servo motor.

#### 1.4.3.2 Disposal

For disposal, send the device, in the original packaging, to the appropriate manufacturer's address.

Region	Disposal Address
China and SEA	<b>A&amp;S Industry Technology (Tianjin) Co., Ltd.</b> No. D9-1/D9-2, Saida International Industrial City Xiqing Economic & Technological District Tianjin 300385, China

#### 1.4.4 Storage

##### NOTICE

- Store only in the manufacturer's original recyclable packaging.
- Climate category 1K4 according to EN 61800-2, IEC 60721-3-2.
- Humidity: 5 to 95% relative humidity, no condensation.
- Maximum stacking height: See "Packaging" (→ p. 13).
- Storage temperature: -25 °C to +55 °C, maximum variation 20K/hr.
- Storage time: Unlimited.

## 1.4.5 Transport

### NOTICE

- Transport is only allowed by qualified personnel in the manufacturer's original recyclable packaging.
  - Avoid shocks, especially to the shaft end.
- Climate Category: 2K3 according to EN 61800-2, IEC 60721-3-2.
- Humidity: 5 to 95% relative humidity, no condensation.
- Temperature: -25 °C to +70 °C, maximum rate of change 20K/hr.
- If the packaging is damaged, check the servo motor for visible damage.
  - Inform the carrier and, if appropriate, the manufacturer.

### 1.4.5.1 Transport Servo Motors with a Weight Greater than 20kg

Observe any transport instructions included in the packaging of the servo motor.

#### **⚠ DANGER** Suspended load!



- Risk of death if load falls!
- Never step under the load while the servo motor is raised.

B1/ 4 x Lifting Bolt Plus Lifting Beam

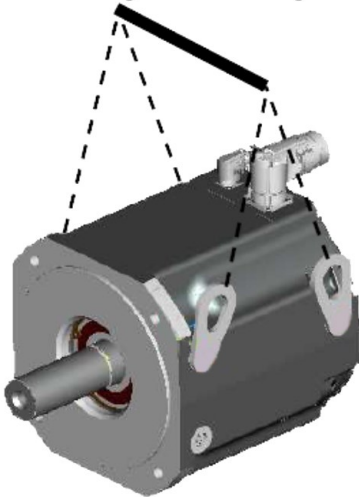

B2/ 2 x Lifting Bolt Plus Lifting Beam

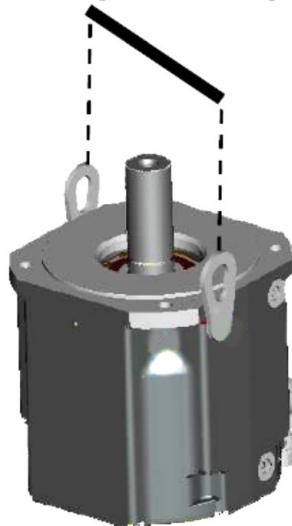

B3/ 2 x Lifting Bolt Plus Lifting Beam



Figure 1-1: Examples: Lifting Beams

### 1.4.5.2 Lifting Eyes

Lifting eyes must be used to safely transport AKME7 servo motors (> 20kg).

- Prior to use, check the lifting eyes for secure fitting and any obvious damages (e.g., corrosion, deformation).
  - Lifting eyes with deformations **must not be used**.
- The fastening screws of the lifting eyes **must be** fully tightened.
  - The lifting eyes **must be** positioned on the supporting surface in an even and flat manner.
- **AKME7 Only:** Kollmorgen recommends the transport tool ZPZM 120/292 for moving the servo motors.
  - Suspension Unit ZPZM 120/292 consists of a beam, suspended to the crane hook and two double-run chain suspenders.

## 1.5 Package

### 1.5.1 Package Supplied

The package contains the servo motor from the AKME series.

### 1.5.2 Nameplate

With standard servo motors, the nameplate uses adhesive on the housing side.

#### 1.5.2.1 AKME2 and AKME3

Two labels for frame sizes 2 and 3:

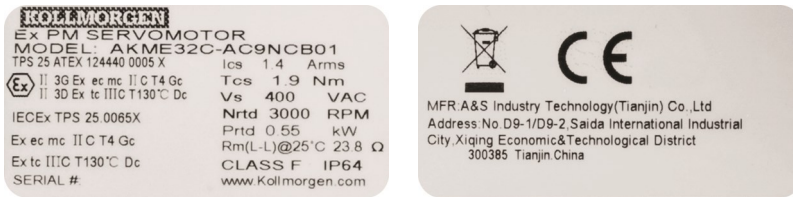

#### 1.5.2.2 AKME4 to AKME7

One label for frame sizes 4 to 7:

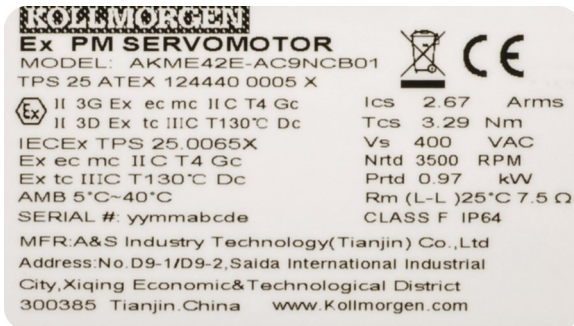

Legend	Description
MODEL	Servo Motor Type
Ics	Standstill Current
Tcs	Standstill Torque
Vs	DC bus link voltage
Nrted	Rated Speed @ $U_n$
Prtd	Rated Power
Rm	Winding Resistance @ 25 °C
SERIAL	Serial Number
AMB	Ambient Temperature Range 5 °C 至 +40 °C
IPXX	Ingress Protection Rating
CLASS F	Insulation Rating

The year and week of manufacturing is coded in the serial number.

The first two digits of the serial number are the year of manufacturing (e.g., 25 is 2025).

The third and fourth digits of the serial number are the week of manufacturing (e.g., 32 is the 32nd week).

## 1.6 General Technical Data

Technical Data	Description
Ambient Temperature	<ul style="list-style-type: none"> <li>5 °C to +40 °C for site altitude up to 1000m AMSL (at rated values).</li> <li>It is vital to consult Kollmorgen's applications department for ambient temperatures above 40 °C and encapsulated mounting of the servo motors.</li> </ul>
Ball Bearing Life	≥ 20,000 operating hours.
Permissible Humidity	5 to 95% relative humidity, no condensation (at rated values).
Power derating (currents and torques)	<p>1%/°K in range 40 °C to 50 °C up to 1000m AMSL. For site altitude above 1000m AMSL and 40 °C:</p> <ul style="list-style-type: none"> <li>6% up to 2000m AMSL</li> <li>17% up to 3000m AMSL</li> <li>30% up to 4000m AMSL</li> <li>55% up to 5000m AMSL</li> </ul> <p>For site altitudes above 1000m AMSL, no de-rating with temperature reduction of 10 °K/1000m.</p>

### NOTE

See the individual servo motor series sections for their respective technical data and dimensional drawings.

## 1.7 Standard Features

---

1.7.1 Feedback .....	19
1.7.2 Flange .....	20
1.7.3 Grounding Bolt .....	20
1.7.4 Holding Brake .....	21
1.7.5 Ingress Protection Class .....	23
1.7.6 Insulation Material Class .....	23
1.7.7 Shaft End, A-side .....	23
1.7.8 Shaft Seal .....	24
1.7.9 Style .....	24
1.7.10 Surface .....	24
1.7.11 Thermal Protective Device .....	25
1.7.12 Vibration Class .....	25

### 1.7.1 Feedback

AKME servo motors are available with multiple feedback encoder options.

- All required AKME servo motor and encoder parameters are pre-configured in Kollmorgen servo drive - WorkBench interface systems.
- When using the servo motor with third-party servo drives, the parameters are in the "AKME - Feedback Specifications" (→ p. 115) and "General Technical Data" (→ p. 17) sections.
- Contact "Support and Services" (→ p. 170) for assistance.

#### 1.7.1.1 Feedback Unit Options and Resolution

##### Feedback Unit Options

■ Safety Capable

				Feedback Resolution				
Code	Designation	AKME Frame Size	Single-Turn or Multi-Turn	Device Resolution (Sin/Cos per Rev., Bits or Lines/Rev.)	AKD Internal Resolution	AKD2G Internal Resolution	# of Absolute Revs.	Accuracy (± arc-mins)
2-	Commutating Encoder	2-7	Single-turn	2048 Lines	8,192	8,192	None	1
AA	BiSS B	2-7	Single-turn	2048 Sin/Cos	27-Bits	32-Bits	1	0.6
AB	Optical Sine Encoder	2-7	Multi-turn				4,096	
CB	SFD-M Smart Feedback Device, Multi-turn	2-6	Multi-turn	24-Bits	24-Bits	24-Bits	65,536	1
GU*	HIPERFACE DSL® Optical Encoder	2-6	Multi-turn	17-Bits	18-Bits	18-Bits	4,096	4
GJ	HIPERFACE Optical Sin/Cos Encoder	2-7	Single-turn	128 Sin/Cos	23-Bits	31-Bits	1	1.33
GK			Multi-turn				4,096	
DA	EnDat® 2.2/01 Optical Sine Encoder	2-4	Single-turn	512 Sin/Cos	25-Bits	32-Bits	1	1
		5-7		2048 Sin/Cos	27-Bits			0.333
DB		2-4	Multi-turn	512 Sin/Cos	25-Bits		4,096	1
		5-7		2048 Sin/Cos	27-Bits			0.333
R-	Resolver Inductive Encoder	2-4	Single-Turn	1 pole pair (16-Bits)	16-Bits	16-Bits	1	10
		5-7						9

\* SICK HIPERFACE DSL® model EEM37-2KF0A017A. Please visit <https://www.sick.com> to download the latest safety data sheet.

#### 1.7.1.2 Feedback and Connector Availability

##### Feedback and Connector Availability

AKME2			AKME3-6			AKME7		
Connector Code	4	9	Connector Code	4	9	Connector Code	4	W*
Feedback Code	R-	•	R-	•		R-	•	•
	2-	•	2-	•		2-	•	•
	AA, AB	•	AA, AB	•		AA, AB	•	•
	CB		CB		•	DA, DB	•	•
	DA, DB	•	DA, DB	•		GJ, GK	•	•
	GJ, GK	•	GJ, GK	•				
	GU		GU		•			

\*AKME74Q Only

## 1.7.2 Flange

IEC flange tolerance according to DIN 42955.

Tolerances of shaft extension run-out and of mounting flanges for rotating electrical machines.

Code	Flange
A	IEC with tolerance N.
B	<ul style="list-style-type: none"> <li>NEMA.</li> <li>See the individual servo motor series sections for their respective technical data and dimensional drawings.</li> </ul>
C	Alternative IEC standard.
D	Other standard.
E	NEMA mount.
G	Alternative IEC standard.
H	Alternative IEC standard.
K	Alternative NEMA mount.
L	NEMA 56 mount.

## 1.7.3 Grounding Bolt



AKME servo motors include a grounding bolt for ATEX / IECEx compliant grounding.

### 1.7.3.1 Ground Bolt Specifications

- Hexagon head screw, ISO 4017:
  - M3 X 5 (AKME2 to AKME4)
  - M4 X 6 (AKME5 to AKME7)
- Tightening Torque: 0.56 Nm
- Ground Cable Specification: No less than 4mm<sup>2</sup>

## 1.7.4 Holding Brake

All servo motors are available with a holding brake option.

- A spring applied brake ( $24V_{DC}$ ) is integrated into the servo motors.
  - When this brake is de-energized, it blocks the rotor.

### **WARNING**



#### **Secure hanging loads!**

**Risk of injury exists for personnel operating the machine.**

- If there is a suspended load (vertical axes) and the servo motor's holding brake is released without the servo drive producing output at the same time, the load may fall down!
- The user should consider:
  - Required local safety standards in the case of hanging loads (vertical axes).
  - The need to ensure personnel safety by using additional safety measures for hazard avoidance.

### **NOTICE**

- The holding brakes are designed as standstill brakes.
  - They are **not** suited for repeated operational braking.
- In the case of frequent, operational braking, premature wear and failure of the holding brake is to be expected.
- The length of the servo motor increases when a holding brake is mounted.
- The holding brake can be controlled directly by the servo drive.
  - **There is no personal safety!**
  - See "Holding Brake Functionality" (→ p. 138).
- The winding is suppressed in the servo drive.
  - Additional circuitry is not required (see the servo drive instruction manual).
- If the holding brake is not controlled directly by the servo drive, additional wiring (e.g., varistor) is required.
  - Contact "Support and Services" (→ p. 170) for assistance.
- See "Brakes - Technical Data" (→ p. 133).

### 1.7.4.1 ATEX / IECEx Compliant Holding Brake Voltage Requirement

**NOTICE**

The applied holding brake voltage must be limited to  $17V_{DC}$  to maintain ATEX / IECEx T4 temperature class compliance.

#### 1.7.4.1.1 Set the Holding Brake Voltage - AKD2G Servo Drive with WorkBench

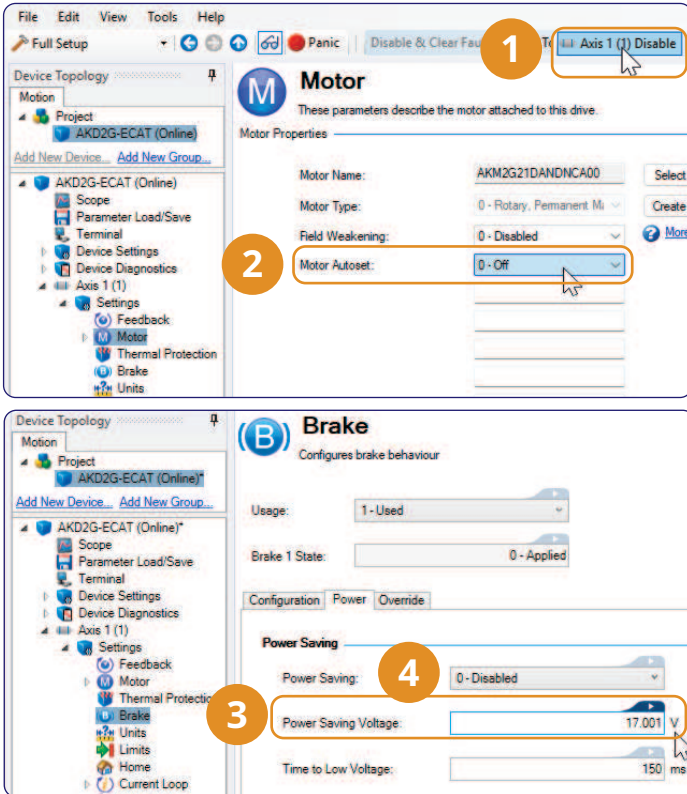

1. Disable the Axis **AXISx.DIS**.
2. Set the **AXISx.MOTOR.AUTOSSET** (Motor Autoset) to 0 (Off).
3. Set the **AXISx.BRAKEPOWERLOW** (Power Saving Voltage) to  $17V_{DC}$ .
4. Set the **AXISx.MOTOR.BRAKEPOWERSAVING** (Power Saving) to 1 (Enabled).

#### 1.7.4.1.2 Set the Holding Brake Voltage - AKD, Kollmorgen Essentials, or 3rd-party Drives

**! IMPORTANT**

- The holding brake power saving feature in WorkBench is only available with AKD2G servo drives.
- Contact Kollmorgen "Support and Services" (→ p. 170) for solutions to reduce the brake voltage for all other AKME servo motor and servo drive configurations.

## 1.7.5 Ingress Protection Class

Per EN 60529.

Standard Servo Motor	Connector Option	Shaft Seal	Protection Class
AKME2 - AKME7	-4, -9, -W	With	IP64

### NOTE

See [Ingress Protection of Servo Motors](#).

## 1.7.6 Insulation Material Class

The servo motors meet the standard for insulation material Class F according to IEC 60085 (UL1446).

## 1.7.7 Shaft End, A-side

Power transmission is made through the cylindrical shaft end A, fit K6 (AKME2 to AKME7: H7) to EN 50347, with a locking thread but **without a fitted keyway**.

- Servo motors are available with keyway and inserted key according to DIN 6885.
  - The shaft with keyway is balanced with short (half) key.
- Bearing life is calculated with 20,000 operating hours.

Order Code	Shaft End	Available For
C	Keyway, closed	AKME2 - AKME7
K	Keyway, open	AKME2 - AKME7
N	Smooth shaft	AKME2 - AKME7

### 1.7.7.1 Coupling

Double-cone collets have proved to be ideal zero-backlash coupling devices, combined, if required, with metal bellows couplings.

### 1.7.7.2 Maximum Axial Force

When assembling pinions or wheels to the axis and use of angular gearheads, axial forces arise.

Servo Motor	AKME2	AKME3	AKME4	AKME5	AKME6	AKME7
Maximum Axial Force (N)	600	600	1400	1740	2200	3000

The maximum values at rated speed are here: "AKME - L10 Servo Motor Bearing Fatigue" (→ p. 141).

### 1.7.7.3 Maximum Radial Force

If the servo motor drives pinions or toothed belts, high radial forces will occur.

Servo Motor	AKME2	AKME3	AKME4	AKME5	AKME6	AKME7
Maximum Radial Force (N)	150	340	500	830	1940	2300

The maximum radial load ratings reflect these assumptions:

- Servo motors are operated with peak torque of the longest member of the frame size.
- Fully reversed load applied to the end of the smallest diameter standard mounting shaft extension.
- Safety factor = 2.

**NOTE**

- Power take-off from the middle of the free end of the shaft allows a 10% increase in  $F_R$ .
- The maximum values at rated speed are here: "AKME - L10 Servo Motor Bearing Fatigue" (→ p. 141).
- See the individual servo motor series sections for their respective technical data and dimensional drawings.

### 1.7.8 Shaft Seal

If the AKME servo motor is connected to a machine flange with an unsealed shaft region, the shaft seal ensures the shaft sealing.

- Shaft seal operation in dry-running mode is prohibited.
  - Contact Kollmorgen for special shaft seal solution in case the dry-running operation is required.
- The Teflon shaft seal ensures the IP67 protection for the shaft area.
- The rated performance is achieved after some hours of shaft seal run-in.
  - No special procedure for run-in is needed.
- Some shedding of the Teflon shaft seal material is normal and does not affect the function.
- The shaft seal is pre-lubricated by FDA grease.

### 1.7.9 Style

The basic style for the AKME servo motors is style IM B 5 according to EN 60034-7.

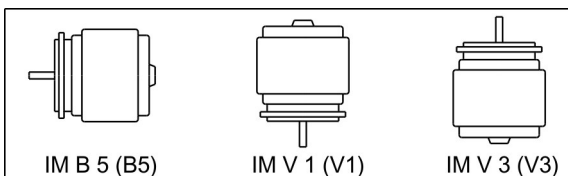

### 1.7.10 Surface

- The servo motors are coated with powder coating in matte black.
- This finish is **not** resistant against solvents (e.g., trichlorethylene, nitro-thinners, or similar).

### 1.7.11 Thermal Protective Device

The explosion-proof servo motor is fitted with a PT-1000 sensor.

- The PTC does not provide any protection against short, heavy overloading.
- With digital feedback systems HIPERFACE DSL and SFD-M (CB), the temperature sensor status is transmitted digitally and evaluated in the servo drive.
- When Kollmorgen-configured feedback cables are used, the sensor is integrated into the monitoring system of the digital servo drive.

#### 1.7.11.1 Thermal Device: Resistance vs. Temperature Curves

Thermal Device curves show the equivalent resistance in ohms that corresponds to a given temperature of the servo motor windings.

The servo drive used with the servo motor must support the selected thermal device for proper operation.

**! IMPORTANT**

- Kollmorgen servo drives can directly interpret information from the servo motor thermal sensors to properly reflect the servo motor winding temperature.
- See "Delta Between Motor Winding and Thermal Device Curve" (→ p. 143) for other servo drives.

**Standard**

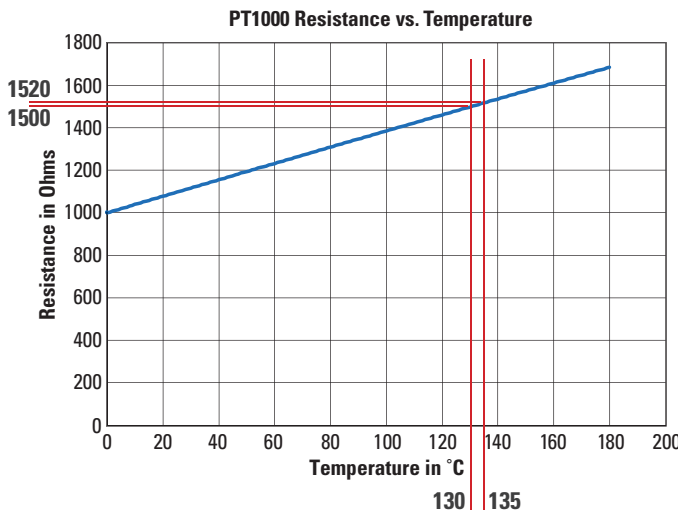

In order to maintain T4/T130°C temperature classification, the PT1000 device resistance must be limited to a range of 1500 - 1520 Ω.

### 1.7.12 Vibration Class

The servo motors are made to vibration class A according to EN 60034-14.

For a speed range of 600RPM to 3600RPM, and a shaft center between 56mm and 132mm, the actual value of the permitted vibration severity is 1.6mm/s.

Velocity [rpm]	Maximum Relative Vibration Displacement [µm]	Maximum Run-out [µm]
<= 1800	90	23
> 1800	65	16

#### 1.7.12.1 Vibration and Shocks

- Vibration according to standard EN 60068-2-6: 2007: Vibration 10G / 10-2000Hz.
- Shocks according to standard EN 60068-2-27: 2008: Shock 100G / 6ms.

## 1.8 Wiring Technology

### 1.8.1 Connectors

**! IMPORTANT**

Kollmorgen Drive and Motor system compatibility and performance cannot be guaranteed if user-customized or third-party cables are used.

- See "Part Number Scheme" (→ p. 7) for connector information.
- See "AKME - Connector Pinouts" (→ p. 120) for pinout information.
- See "AKME - Cables" (→ p. 124) for AKME cable connector pinouts.

#### Connector Options

Code	Thermal Sensor*	Used with	IP Rating**	Connection type	Description
4	PT1000	AKME2-AKME7	IP67	2 threaded connectors, size 1.0 (M23)	Angled, rotatable, mounted on motor
9		AKME2-AKME6	IP67	1 threaded connector, size 1.0 (M23)	Angled, rotatable, mounted on motor
W		AKME7	IP67	1 feedback threaded connector, size 1.0 (M23) 1 power threaded connector, size 1.5 (M40)	Angled, rotatable, mounted on motor

\*For Thermal Device Curves, reference see the Thermal Sensor Protective Devices page.

\*\*IP ratings shown apply ONLY to the connector and the connector base/bushing on motor.

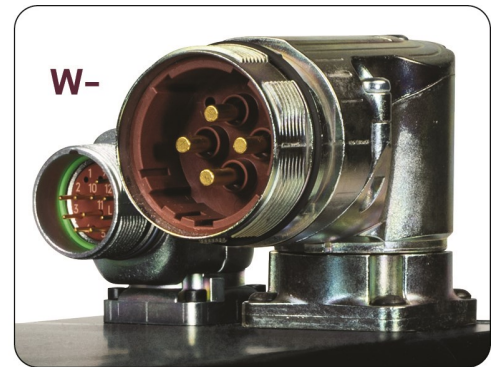

### 1.8.2 Cable Mating Connector Part Numbers

AKME Motor Connector	Code	Cable Mating Connector P/N	Manufacturer
M23 Power/Hybrid	4-, 9-	1605617	Phoenix
M23 Feedback 12-pin	4-, W-	1069313	Phoenix
M23 Feedback 17-pin	4-, W-	1619754	Phoenix
M40 Power	W-	CSTA-263-NN-00-26-0001-000	Intercontec

### 1.8.3 Wire Cross Sections

- See the KSN article [Hybrid Cables](#) for technical descriptions of hybrid cables.
- "Power Cable, Combination Cable" (→ p. 27)
- "Feedback Cable" (→ p. 27)
- "Hybrid Cable" (→ p. 27)

#### 1.8.3.1 Power Cable, Combination Cable

Combination cables contain 4 power lines and 2 additional lines for servo motor holding brake control.

- The brackets (...) show the shielding.
- Current carrying capacity according to EN 60204-1 : 2006, Table 6, Column B2.

Cable	Cross Section Combination Cable	Current Carrying Capacity
(4 x 1)	(4 x 1 + (2 x 0.75))	0A < Arms ≤ 10.1A
(4 x 1.5)	(4 x 1.5 + (2 x 0.75))	10.1A < Arms ≤ 13.1A
(4 x 2.5)	(4 x 2.5 + (2 x 1))	13.1A < Arms ≤ 17.4A
(4 x 4)	(4 x 4 + (2 x 1))	17.4A < Arms ≤ 23A
(4 x 6)	(4 x 6 + (2 x 1))	23A < Arms ≤ 30A

#### 1.8.3.2 Feedback Cable

Type	Cross Section	Remarks
Comcoder	(8 x 2 x 0.25)	Incremental Encoder + Hall
Encoder	(7 x 2 x 0.25)	BiSS, EnDat, HIPERFACE Analog
Resolver	(4 x 2 x 0.25)	

#### 1.8.3.3 Hybrid Cable

- **SFD-M and HIPERFACE DSL**: 4 power lines, 2 brake lines, and 2 signal lines.

Type	Cross Section
SFD-M and HIPERFACE DSL	(4 x 1.5 + (2 x 0.34) + (2 x 0.75))
SFD-M and HIPERFACE DSL	(4 x 2.5 + (2 x 0.34) + (2 x 1.0))
SFD-M and HIPERFACE DSL	(4 x 4.0 + (2 x 0.34) + (2 x 1.0))

## 1.9 Mechanical Installation

### NOTE

See the individual servo motor series sections for their respective technical data and dimensional drawings.

### 1.9.1 Installation and Operating Conditions

- The servo motors can only be used in ambient temperatures up to 40 °C.

### NOTICE

- During mounting and operation, protect the servo motor from mechanical effects which can cause the scratches or cracks on the painted surface.
- Mishandling increases the risk of corrosion.

### 1.9.2 Flange Mounting

### ! IMPORTANT

Only qualified staff with mechanical engineering knowledge are permitted to assemble the servo motor.

#### 1.9.2.1 Flange Mounting Guidelines

### NOTICE

- Protect the servo motor from unacceptable stresses.
  - During transport and handling, no components must be damaged.
- The site must be free of conductive and aggressive material.
  - For V3-mounting (shaft end upwards), make sure that no liquids can enter the bearings.
  - Contact Kollmorgen if an encapsulated assembly is required.
- Verify there is unhindered ventilation of the servo motors.
- Observe the permissible ambient and flange temperatures.
  - For ambient temperatures above 40 °C, contact the Kollmorgen applications department beforehand.
  - Verify there is adequate heat transfer in the surroundings and the servo motor flange.
- The servo motor flange and shaft are especially vulnerable during storage and assembly - avoid brute force.
  - It is important to use the provided locking thread to tighten couplings, gear wheels, pulley wheels, and warm up the drive components, where possible.
  - Blows, or the use of force, leads to damage to the bearings and the shaft.

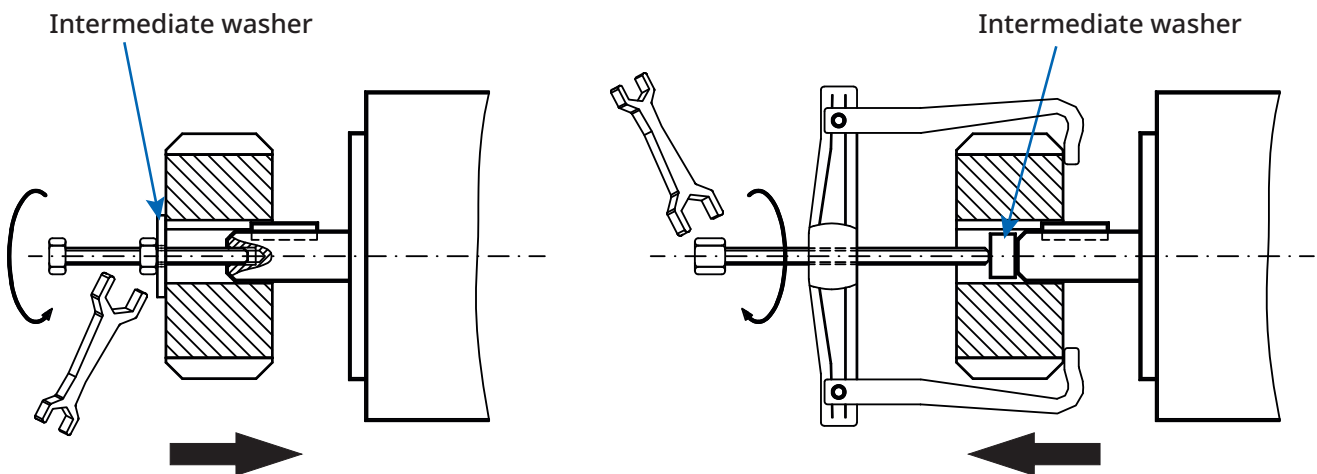

Figure 1-2: Example: Intermediate Washer

**NOTICE**

- Wherever possible, use only backlash-free, frictionally-locking collets or couplings.
  - Verify correct alignment of the couplings.
  - A displacement causes unacceptable vibration and the destruction of the bearings and the coupling.
- In all cases, **do not** create a mechanically constrained servo motor shaft mounting by using a rigid coupling with additional external bearings (e.g., in a gearbox).
- Identify the number of servo motor poles and resolver poles (if applicable).
  - Verify the correct setting is made in the used servo drive.
  - An incorrect setting can lead to the destruction of the servo motor, especially with small servo motors.
- If possible, avoid axial loads on the servo motor shaft.
  - Axial loading significantly shortens the life of the servo motor.
- Check the compliance to the permitted radial and axial forces  $F_R$  and  $F_A$ .
  - When a toothed belt drive is used, the minimal permitted diameter of the pinion follows from this equation:  $d_{\min} \geq (M_0/F_R)^2$ .

## 1.10 Electrical Installation



### ! IMPORTANT

Only qualified staff with electrical engineering knowledge are permitted to assemble the servo motor.

### ! DANGER



#### Dangerous Voltage!

- Always verify the servo motors are de-energized during assembly and wiring.
  - No voltage can be switched on for any piece of equipment which is to be connected.
- There is a risk of death or severe injury from touching exposed contacts.
  - Verify the switch cabinet remains turned off (e.g., barrier, warning signs etc.).
  - The individual voltages are only turned on again during setup.
- Risk of electric shock!
  - Never undo the electrical connections to the servo motor while it is energized.
  - In unfavorable circumstances, electric arcs can arise causing harm to people and damaging contacts.
- The residual charge in the capacitors of the drive can produce dangerous voltages up to 10 minutes after the mains supply has been switched off.
  - Even when the servo motor is not rotating, control and power leads may be energized.
- Measure the DC-link voltage and wait until it has fallen below  $60V_{DC}$ .
- The ground symbol () indicates that you must provide an electrical connection.
  - This connection must have as large a surface area as possible between the unit indicated and the mounting plate in the switch cabinet.
  - The symbol is found in the wiring diagrams.
- This connection is to suppress HF interference and must not be confused with the PE (protective earth) symbol () (protective measure to EN 60204).

### NOTE

### NOTE

### NOTE

To connect the servo motor, refer to the wiring diagrams in the servo drive Installation and Setup Instructions.

- Pinouts for the motor connectors are here: "AKME - Connector Pinouts" (→ p. 120).
- Pinouts for the cable connectors (both motor and drive end) are here: "AKME - Cables" (→ p. 124)
- Pinouts of the servo drive's end are in the instruction manual of the servo drive.

## 1.10.1 Electrical Installation Guide

1. Verify the servo drive and servo motor match each other.
  - a. Compare the rated voltage and rated current of the unit.
  - b. Install the wiring according to the wiring diagram in the instruction manual of the servo drive.  
The connections to the servo motor are here: "AKME - Connector Pinouts" (→ p. 120).
2. Install all cables carrying a heavy current with an adequate cross-section per EN 60204.  
See the individual servo motor series sections for their respective technical data and dimensional drawings.

### NOTE

- For long servo motor cables (>25m), and depending on the type of servo drive used, a servo motor choke (3YL or 3YLN) must be switched into the servo motor cable.
- See the servo drive instruction manual and accessory manual.

3. Verify there is proper earthing of the servo drive and the servo motor.
  - a. Use correct earthing and EMC-shielding according to the used servo drive installation manual.
  - b. Earth ground the mounting plate and servo motor casing.
4. If a servo motor power cable is used, and it includes integral brake control leads, the brake control leads must be shielded.
  - a. The shielding must be connected at both ends.
  - b. See the servo drive instruction manual.

### 1.10.1.1 Cable Connection

1. Route power cables as separately as possible from control cables.
2. Connect the feedback device.
3. Connect the servo motor cables.
4. Install servo motor chokes (if applicable) close to the servo drive.
5. Connect the holding brake, if used.

### 1.10.1.2 Cable Material Requirements - Capacity

- Servo motor cable: < 150 pF/m.
- Resolver cable: < 120 pF/m.

### 1.10.1.3 Shields

1. Connect shields to shielding terminals or EMC connectors at both ends.
2. Connect the shielding at both ends.
3. Connect all shielding via a wide surface-area contact (low impedance) and metalized connector housings or EMC-cable glands.

## 1.10.2 Connect the Servo Motor with Pre-assembled Cables

### ! IMPORTANT

Kollmorgen Drive and Motor system compatibility and performance cannot be guaranteed if user-customized or third-party cables are used.

### ! IMPORTANT

The use of Kollmorgen pre-assembled cables is required to maintain AKME ATEX / IECEx compliance.

- Install the wiring in accordance with the valid standards and regulations.
- Use only Kollmorgen pre-assembled, shielded cables for the resolver and power connections.
- Incorrectly installed shielding leads to EMC interference and has an adverse effect on system function.
- The maximum cable length is defined in the instruction manual of the used servo drive.

### NOTE

For a detailed description of the configured cables, see "AKME - Cables" (→ p. 124).

## 1.11 Setup

### **IMPORTANT**

Only specialist personnel with extensive knowledge in electrical engineering / drive technology are allowed to commission the drive unit of the servo drive and servo motor.

### **DANGER**



#### High Voltages!

- Deadly voltages can occur up to  $900V_{DC}$ .
- Risk of electric shock!
  - Verify that all live connection points are safe against accidental contact.
  - Never undo the electrical connections to the servo motor while it is energized.
- The residual charge in the capacitors of the drive can produce dangerous voltages up to 10 minutes after the mains supply has been switched off.
  - Even when the servo motor is not rotating, control and power leads may be energized.
- Measure the DC-link voltage and wait until it has fallen below  $60V_{DC}$ .

### **CAUTION**



#### Hot Surface!

- Danger of light burns!
  - The surface temperature of the servo motor can exceed  $100\text{ °C}$  in operation.
- Measure the temperature of the servo motor.
  - Wait until the servo motor has cooled below  $40\text{ °C}$  before touching it.

### **CAUTION**

#### Beware of Unplanned Movements!

- The drive performing unplanned movements during commissioning cannot be ruled out.
- Verify that, if the servo motor moves unintentionally, no danger can result to personnel or machinery.
- The safety measures that must be taken for a task are based on the risk assessment of the application.

### 1.11.1 Setup Procedure

<b>NOTE</b>
-------------

- This procedure is an example of the setup.
- A different method may be appropriate or necessary, depending on the application of the equipment.

1. Check the assembly and orientation of the servo motor.
2. Check the drive components (e.g., clutch, gear unit, belt pulley) for the correct seating and setting.
3. Observe the permissible radial and axial forces.
4. Check the wiring and connections to the servo motor and the servo drive.
5. Check that the earth grounding is correct.
6. For a servo motor **with** a brake:
  - Test the brake by applying  $24V_{DC}$  ( $17V_{DC}$  for ATEX / IECEx compliance) and confirm the brake disengages and the rotor revolves freely.
  - See "ATEX / IECEx Compliant Holding Brake Voltage Requirement" (→ p. 22).
7. For a servo motor **without** a brake:
  - Check whether the rotor of the servo motor revolves freely.
8. Listen for grinding noises.
9. Check that all the required measures against accidental contact with live and moving parts have been implemented.
10. Based on the risk assessment, conduct any further tests specifically required for the system.
11. Commission the drive according to the servo drive setup instructions.
12. In multi-axis systems, individually commission each drive unit (servo drive and servo motor).

## 1.12 Troubleshooting

There can be many different reasons for a fault, depending on the system setup.

- The fault causes in the tables are those which directly influence the servo motor.
- Peculiarities which appear in the control loop behavior can usually be traced back to an error in the parameterization of the servo drive.
- The documentation for the servo drive and the setup software provides information.
- For multi-axis systems, there may be further hidden reasons for faults.

---

<b>1.12.1 Brake Does Not Engage</b> .....	<b>35</b>
<b>1.12.2 Error Message: Output Stage Fault</b> .....	<b>35</b>
<b>1.12.3 Error Message: Resolver</b> .....	<b>35</b>
<b>1.12.4 Error Message: Servo Motor Brake</b> .....	<b>35</b>
<b>1.12.5 Error Message: Servo Motor Temperature</b> .....	<b>35</b>
<b>1.12.6 Servo Motor does not Rotate</b> .....	<b>36</b>
<b>1.12.7 Servo Motor Oscillates</b> .....	<b>36</b>
<b>1.12.8 Servo Motor Runs Away</b> .....	<b>36</b>

### 1.12.1 Brake Does Not Engage

Possible Cause	Correction Measures
Faulty brake.	Replace the servo motor.
Servo motor shaft is axially overloaded.	<ul style="list-style-type: none"> <li>• Check the axial load, reduce it.</li> <li>• Replace the servo motor, since the bearings have been damaged.</li> </ul>
Required holding torque is too high.	Check the dimensioning.

### 1.12.2 Error Message: Output Stage Fault

Possible Cause	Correction Measures
Servo motor cable has short-circuit or earth short.	Replace the cable.
Servo motor has short-circuit or earth short.	Replace the servo motor.

### 1.12.3 Error Message: Resolver

Possible Cause	Correction Measures
Break in Resolver cable, cable crushed, or similar.	Check the cables.
Resolver connector is not properly plugged in.	Check the connector.

### 1.12.4 Error Message: Servo Motor Brake

Possible Cause	Correction Measures
Faulty servo motor holding brake.	Replace the servo motor.
Short-circuit in the supply voltage lead to the servo motor holding brake.	Remove the short-circuit.

### 1.12.5 Error Message: Servo Motor Temperature

Possible Cause	Correction Measures
Loose Resolver connector or break in the Resolver cable.	<ul style="list-style-type: none"> <li>• Check the connector.</li> <li>• Replace the Resolver cable, if necessary.</li> </ul>
Servo motor thermosensor has switched.	<ul style="list-style-type: none"> <li>• Wait until the servo motor has cooled down.</li> <li>• Investigate why the servo motor becomes too hot.</li> </ul>

### 1.12.6 Servo Motor does not Rotate

Possible Cause	Correction Measures
Brake is not released.	Check the brake controls.
Break in the setpoint lead.	Check the setpoint lead.
Drive is mechanically blocked.	Check the mechanism.
Servo motor phases are in the wrong sequence.	Correct the phase sequence.
Servo drive is not enabled.	Supply ENABLE signal.

### 1.12.7 Servo Motor Oscillates

Possible Cause	Correction Measures
Break in the Resolver cable shielding.	Replace the Resolver cable.
Servo drive gain too high.	Use the servo motor default values.

### 1.12.8 Servo Motor Runs Away

Possible Cause	Correction Measures
Servo motor phases are in the wrong sequence.	Correct the phase sequence.

### 1.13 Technical Data Terminology

**NOTE**

- See the individual servo motor series sections for their respective technical data and dimensional drawings.
- All data is valid for 40 °C environmental temperature and 95K overtemperature of the winding.
- Determination of nominal data with constant temperature of adapter flange of 65 °C.
- The data can have a tolerance of +/- 10%.

Term	Definition
Peak Current, (pulse current) $I_{0max}$ [A]	<ul style="list-style-type: none"> <li>• The Peak Current (effective sinusoidal value) is several times the rated current, depending on the servo motor winding.</li> <li>• The actual value is determined by the peak current of the drive which is used.</li> </ul>
Rated Torque, $M_n$ [Nm]	<ul style="list-style-type: none"> <li>• The Rated Torque is produced when the servo motor is drawing the rated current at the rated speed.</li> <li>• The Rated Torque can be produced indefinitely at the rated speed in continuous operation (S1).</li> </ul>
Release Delay Time $t_{BRH}$ [ms] / Engage Delay Time $t_{BRL}$ [ms] of the brake.	These constants define the response times of the holding brake when operated with the rated voltage from the servo drive.
Rotor Moment of Inertia, $J$ [kg·cm <sup>2</sup> ]	<p>The constant J is a measure of the acceleration capability of the servo motor.</p> <p>Example: At <math>I_0</math>, the acceleration time <math>t_b</math> from 0 to 3000RPM is given as:</p> $t_b [s] = \frac{3000 \cdot 2\pi}{M_0 \cdot 60s} \cdot \frac{m^2}{10^4 \cdot cm^2} \cdot J$ <p>with <math>M_0</math> in Nm and J in kg·cm<sup>2</sup>.</p>
Standstill Current, $I_{0rms}$ [A]	The standstill current is the effective sinusoidal current which the servo motor draws at $0 < n < 100$ RPM to produce the standstill torque.
Standstill Torque, $M_0$ [Nm]	The standstill torque can be maintained indefinitely at a speed $0 < n < 100$ RPM and rated ambient conditions.
Thermal Resistance, $R_{thw-a}$ [deg. C/watt]	<ul style="list-style-type: none"> <li>• The Thermal Resistance is a measurement of steady state temperature rise per unit of energy dissipated from losses.</li> <li>• This value assumes the servo motor is housed and mounted to an Aluminum heat sink.</li> <li>• See the individual servo motor series sections for their respective technical data and dimensional drawings.</li> </ul>
Thermal Time Constant, $t_{th}$ [min]	<ul style="list-style-type: none"> <li>• The constant <math>t_{th}</math> defines the time for the cold servo motor, under a load of <math>I_0</math>, to heat up to an over-temperature rise of <math>0.63 \times 10^5</math> °K.</li> <li>• This temperature rise happens in a much shorter time when the servo motor is loaded with the peak current.</li> </ul>
Torque Constant, $K_{Trms}$ [Nm/A]	<ul style="list-style-type: none"> <li>• The Torque Constant defines how much torque in Nm is produced by the servo motor with 1A r.m.s. current.</li> <li>• The relationship is <math>M=I \times K_T</math> (up to <math>I = 2 \times I_0</math>).</li> </ul>
$U_N$	Rated mains voltage.
$U_n$	<ul style="list-style-type: none"> <li>• DC-Bus link voltage.</li> <li>• <math>U_n = \sqrt{2} \cdot U_N</math></li> </ul>

Term	Definition
Voltage Constant, $K_{E_{rms}}$ [mV/min <sup>-1</sup> ]	<ul style="list-style-type: none"><li>• The Voltage Constant defines the induced servo motor EMF, as an effective sinusoidal value between two terminals, per 1000RPM.</li><li>• Measured at 25 °C.</li></ul>

## 2 中文

<b>2.1 关于本手册</b>	<b>41</b>
2.1.1 使用的符号	42
2.1.2 所用缩写	42
<b>2.2 命名规则</b>	<b>43</b>
<b>2.3 安全</b>	<b>44</b>
2.3.1 要求专业人员!	44
2.3.2 阅读文档!	44
2.3.3 注意技术数据!	44
2.3.4 执行风险评估!	44
2.3.5 固定轴键!	45
2.3.6 安全运输!	45
2.3.7 安全警告	46
2.3.8 按说明使用	47
2.3.9 ATEX特定使用条件	48
2.3.10 禁止用途	48
<b>2.4 产品维护与储存</b>	<b>49</b>
2.4.1 维护与清洁	50
2.4.2 包装	50
2.4.3 维修与处置	51
2.4.4 储存	51
2.4.5 运输	52
<b>2.5 包装</b>	<b>53</b>
2.5.1 包装供应	53
2.5.2 铭牌	53
<b>2.6 一般技术数据</b>	<b>55</b>
<b>2.7 标准规格</b>	<b>56</b>
2.7.1 反馈	57
2.7.2 法兰	58
2.7.3 接地螺栓	58
2.7.4 抱闸	59
2.7.5 防护等级	61
2.7.6 绝缘材料等级	61

---

2.7.7 轴端, A侧 .....	61
2.7.8 轴密封件 .....	62
2.7.9 安装方式 .....	62
2.7.10 表面 .....	62
2.7.11 热保护装置 .....	63
2.7.12 振动等级 .....	64
<b>2.8 接线技术 .....</b>	<b>65</b>
2.8.1 连接器 .....	65
2.8.2 电缆连接器部件编号 .....	65
2.8.3 芯线截面积 .....	65
<b>2.9 机械安装 .....</b>	<b>67</b>
2.9.1 安装和操作条件 .....	67
2.9.2 法兰安装 .....	67
<b>2.10 电气安装 .....</b>	<b>69</b>
2.10.1 电气安装指南 .....	70
2.10.2 将伺服电机与预装电缆连接 .....	71
<b>2.11 设置 .....</b>	<b>72</b>
2.11.1 设置步骤 .....	73
<b>2.12 故障排除 .....</b>	<b>74</b>
2.12.1 抱闸无法使用 .....	75
2.12.2 错误信息:输出级故障 .....	75
2.12.3 错误消息:旋转变压器 .....	75
2.12.4 错误信息:伺服电机抱闸 .....	75
2.12.5 错误信息:伺服电机温度 .....	75
2.12.6 伺服电机不转动 .....	76
2.12.7 伺服电机振荡 .....	76
2.12.8 伺服电机失控 .....	76
<b>2.13 技术数据术语 .....</b>	<b>77</b>

## 2.1 关于本手册

本手册介绍了AKME系列ATEX防爆电机。

这些电机与 Kollmorgen 伺服驱动器一同用于驱动系统。

请阅读所有系统文档：

- 伺服驱动器的说明手册。
- 总线通信手册（例如CANopen或EtherCAT）。
- 关于驱动器设置软件的在线帮助。
- 各地区的附件手册。
- AKME系列伺服电机的技术说明。
- 更多背景信息请参见开发者网络，网址：[Kollmorgen Support Network](#)。

<b>注意</b>
-----------

请联系 Kollmorgen 客户支持中心，获取安装手册的印刷版。

## 2.1.1 使用的符号

符号	含义
 <b>危险</b>	表示一种危险情况，如果不加以避免， <b>将会导致人员死亡或严重受伤。</b>
 <b>警告</b>	表示一种危险情况，如果不加以避免， <b>可能会导致人员死亡或严重受伤。</b>
 <b>小心</b>	表示一种危险情况，如果不加以避免，可能会导致人员轻度或中度受伤。
<b>通知</b>	表示如果不加以避免，可能会导致财产损失。
<b>注意</b>	表示有用信息。
 <b>重要事项</b>	表示可能影响结果的具体信息。
 <b>提示</b>	表示便于使用设备、软件或固件的有用信息。
	危险警告（通用）。 危险类型由符号旁的文字说明。
	警告：电力及其影响带来的危险。
	警告：高温表面存在危险。
	警告：悬吊负载存在危险。

## 2.1.2 所用缩写

**注意** 在本文件中，符号 (→ p. 53) 表示：参见第 53 页。

## 2.2 命名规则

**重要事项**

- 命名规则仅用于产品识别。
- 请勿用于订购流程，因为并非所有功能组合都可实现。

**AKME 5 3 G - A C 9 2 CB 01**

AKME Series

Flange Size

2	58 mm
3	70 mm
4	84 mm
5	108 mm
6	138 mm
7	188 mm

Rotor Stack Length

**AKMEx Availability**

		2	3	4	5	6	7
1	1 stack	•	•	•	•		
2	2 stacks	•	•	•	•	•	•
3	3 stacks	•	•	•	•	•	•
4	4 stacks	•		•	•	•	•
5	5 stacks					•	

Winding Type

B C D E F G H J K L M N P Q

Mount

- A IEC with tolerance N
- B NEMA
- C Alternative IEC standard
- D Other standard
- E NEMA mount
- G Alternative IEC standard
- H Alternative IEC standard
- K Alternative NEMA mount
- L NEMA mount
- S Special

Shaft

- C Keyway
- K Open keyway
- N Smooth shaft
- S Special

Customization/Seal

- 01 ATEX Standard motor with shaft seal
- 0X ATEX Customized motor

Feedback Device

**Hybrid Single-Cable Options**

- CB SFD-M (AKME 2-6)
- GU HIPERFACE DSL ■ Safety Capable (AKME 2-6)

**Dual-Cable Options**

- 2- Comcoder 2048 Lines (AKME 2-7)
- AA BiSS B Single-turn (AKME 2-7)
- AB BiSS B Multi-turn (AKME 2-7)
- DA EnDAT 2.2/01 Single-turn (AKME 2-7)
- DB EnDAT 2.2/01 Multi-turn (AKME 2-7)
- GJ HIPERFACE Single-turn (AKME 2-7)
- GK HIPERFACE Multi-turn (AKME 2-7)
- R- Resolver (AKME 2-7)
- S- Special

Brake

- 2 24 V holding brake
- N Without brake

Connectors

- 4 Dual 90° M23 connectors, motor-mounted (AKME 2-7, except AKME7 > 20 A)
- 9 Single 90° hybrid connector, motor-mounted (AKME2-6)
- W Dual 90° M40 connector and M23 feedback connector, motor-mounted (AKME7 > 20 A)

Base Model	Mount-Shaft Availability																				
	AC	AK	AN	BK	BN	CC	CK	CN	DC	DK	DN	EF	EK	EN	GC	GN	HC	HN	KK	LK	
AKME2	•		•		•		•		•		•		•		•		•		•		•
AKME3	•		•		•		•		•		•		•		•		•		•		•
AKME4	•		•		•		•		•		•		•		•		•		•		•
AKME5	•		•		•		•		•		•		•		•		•		•		•
AKME6	•		•		•		•		•		•		•		•		•		•		•
AKME7	•		•		•		•		•		•		•		•		•		•		•

## 2.3 安全

### 2.3.1 要求专业人员!



仅具备相关资质的人员才能执行运输、装配、设置和维护等任务。  
具备相关资质的人员指的是熟悉电机运输、安装、装配、调试和操作，并有承担相关责任所需最低资质的人员。

- 电气安装：仅限具备相关电气资质的人员。
- 机械安装：仅限具备相关机械资质的人员。
- 设置：仅限具备广泛的电气工程设计和驱动器技术知识的合格人员。
- 运输：仅限具备静电敏感元件处理知识的人员。

具备相关资质的人员必须知晓并遵循 IEC 60364 / IEC 60664 和国家事故预防法规。

### 2.3.2 阅读文档!



在安装和调试前，请阅读相应的文档。

- 电机处理不当可能导致人员受伤或财产损失。
- 严格遵守安装要求的技术资料。
- 操作人员必须确保所有受托操作伺服电机的人员都已阅读并理解了手册，并且遵守了手册中的安全注意事项。

### 2.3.3 注意技术数据!



- 请遵循技术数据及相应的连接规范（铭牌和文档）。
- 若超出允许的电压值或电流值，则电机可能会由于高温等原因而损坏。

### 2.3.4 执行风险评估!



机器制造商必须：

- 对机器进行风险评估。
- 采取适当措施，确保意外移动不会造成人员伤亡或财产损失。
- 根据风险评估结果，专业人员可能需要承担额外的职责。

### 2.3.5 固定轴键!



- 在让电机无耦合负载运行前，请拆除轴上已安装的键，以免键被离心力甩出而造成严重后果。
- 当产品送达时，轴键上有塑料保护盖。

### 2.3.6 安全运输!



- 仅可使用起重工具来提升和移动重量超过 20kg 的伺服电机（例如 AKME6 和 AKME7）。
- 独自搬运物品可能导致背部受伤。
- 务必留意[运输](#)中的信息。

## 2.3.7 安全警告

Symbol	Description
 <b>小心</b> 	<p><b>高温表面!</b></p> <p>在运行过程中，电机的表面温度可能非常高（具体取决于其保护类别）。</p> <ul style="list-style-type: none"> <li>• 注意避免轻微烫伤!</li> <li>• 其表面温度可能会超过100 °C。</li> <li>• 测量温度，然后等待至电机冷却至 40 °C 以下后再接触它。</li> </ul>
 <b>危险</b> 	<p><b>接地! 高电压!</b></p> <p>确保电机外壳安全接地到开关柜中的 PE（保护性接地）汇流排至关重要。</p> <ul style="list-style-type: none"> <li>• 注意电击危险。 <ul style="list-style-type: none"> <li>• 若没有低电阻接地，将无法保障人员安全，且存在电击死亡风险。</li> </ul> </li> <li>• 无光学显示也不能保证无电压。 <ul style="list-style-type: none"> <li>• 即使在电机轴未旋转时，电源接线上也可能带有电压。</li> </ul> </li> <li>• 严禁在运行过程中拔下任何连接器。 <ul style="list-style-type: none"> <li>• 接触裸露触点存在死亡或重伤风险。</li> <li>• 即使在电机轴未旋转时，电源接线也可能带电。</li> <li>• 这可能导致闪络，造成人员受伤或触点损坏。</li> </ul> </li> <li>• 断开伺服驱动器电源电压后，等待数分钟再接触任何通常带电的组件（例如触点、螺栓连接）或断开任何连接。</li> <li>• 在关闭电源电压数分钟后，伺服驱动器上的电容器仍可能带有危险电压。 <ul style="list-style-type: none"> <li>• 为了安全起见，请测量直流链路电压并等待至电压降至 60 V 以下。</li> </ul> </li> </ul>
 <b>警告</b> 	<p><b>保护悬挂负载!</b></p> <ul style="list-style-type: none"> <li>• 内置的保持抱闸并不能确保功能安全!</li> <li>• 悬挂负载（垂直轴）需要额外的外部机械抱闸来确保人员安全。</li> </ul>

## 2.3.8 按说明使用

- AKME 系列同步伺服电机专为工业机器人、机床、纺织和包装机械以及其他具有类似高动态性能要求的机器的驱动器 而设计。
- 必须遵循和评估集成在电机绕组上的温度传感器。
- 用户仅被允许在本文档规定的环境条件下操作伺服电机。
- AKME 系列电机只能由具备速度和/或转矩控制的伺服驱动器驱动。
- 电机作为组件安装于电气设施或机器中，并仅可作为该类设施或机器的集成组件进行调试和运行。
- 抱闸设计为静态抱闸，不适用于重复操作制动。
- 仅当使用由 Kollmorgen 提供的组件（伺服驱动器、电机、电缆等）时，才能保证 CE 符合性声明中提到的伺服系统的合规性。
  - 参见 [Approvals](#).

### 注意

1. 安装设备后，请立即连接 PE 连接器，作为第一个电气连接。
2. 插入所有其他线路和连接器。
3. 拆卸时，请最后断开 PE 连接器。

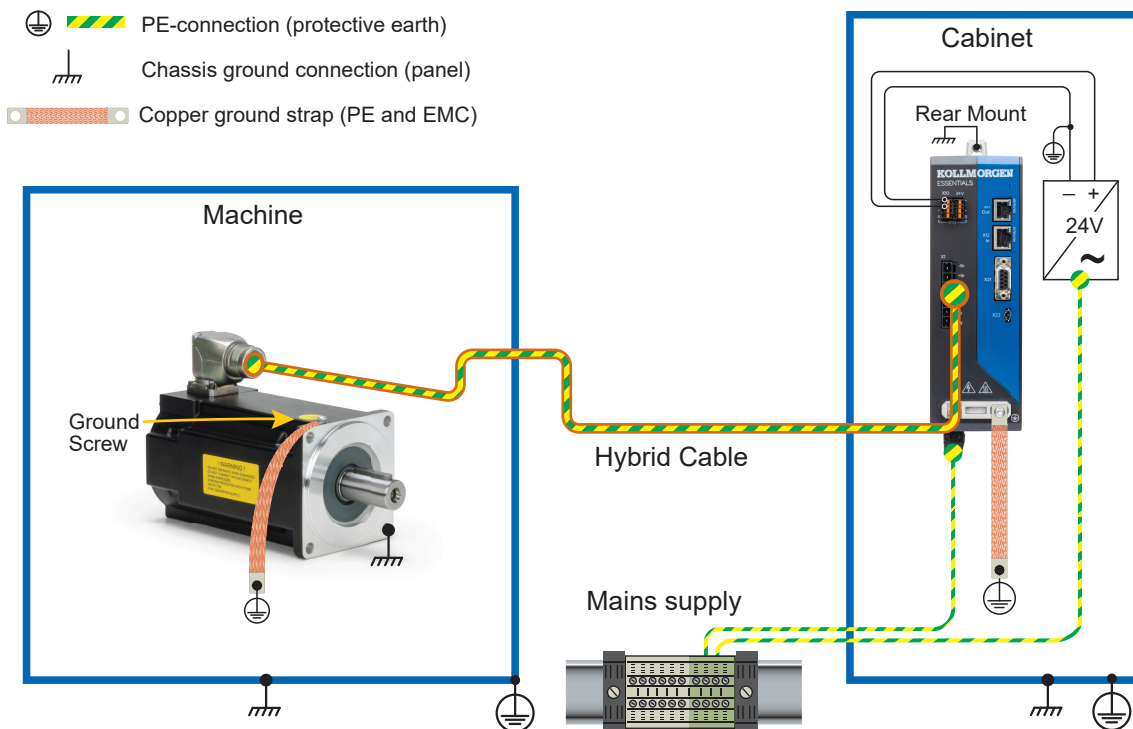

### 2.3.9 ATEX特定使用条件

- 伺服电机必须按照制造商用户手册中的说明与驱动器配合使用。
  - 伺服电机必须符合其电气规格和运行特性。
  - 变频器的选择必须符合本证书中规定的参数。
  - 驱动器的最大允许短路电流为 300A。
- 防爆电机的性能数据必须在符合性证书附件中提供的技术数据规定的范围内使用。
- 连接器与伺服电机一起进行测试，以确保完全符合 IEC 60079-0 标准的防护等级要求。
  - 对于 AKME2 至 AKME7 系列，配套连接器和电缆必须按照用户手册中指定的类型进行选择。
- 抱闸仅用作保持位置。
- 每个伺服电机都应配备一个热保护器，该保护器应连接到伺服电机控制电路，以便在超过规定的温度等级时断开电源。
- 对于在2区危险区域安装：
  - 应提供瞬态保护，其设定值不得超过设备供电端子处额定峰值电压的140%（参见 IEC 60079-7附录H.5）。
  - 该设备拟安装在污染等级为2级或更低的环境中，污染等级应符合IEC 60664-1的定义（参见IEC 60079-7附录H.3）。

### 2.3.10 禁止用途

- 禁止将伺服电机直接用于供电网络或市电。
- 在以下情况下禁止使用伺服电机：
  - 接触食品和饮料。
  - 含有腐蚀性酸、碱、油、蒸汽、粉尘的环境。
- 请勿在危险场所操作伺服电机，且不得移除任何固定螺钉或盖板。
- 伺服电机处于危险场所时，请勿移除任何螺钉或盖板。
- 若安装电机的机器为以下情形，则禁止调试电机：
  - 不满足 CE 机器指令的要求。
  - 不符合 EMC 指令。
  - 不符合低电压指令。
- 严禁使用无进一步辅助设备的内置抱闸来确保功能性安全。

## 2.4 产品维护与储存

---

2.4.1 维护与清洁 .....	50
2.4.2 包装 .....	50
2.4.3 维修与处置 .....	51
2.4.4 储存 .....	51
2.4.5 运输 .....	52

## 2.4.1 维护与清洁

### 通知

- 维护和清洁工作必须由合格人员进行。
- 开启伺服电机将导致保修失效。
- 每年一次或运行2,500小时后：
  - 检查伺服电机是否有轴承异响。
  - 若听到任何异常噪音，请立即停止伺服电机的运行。
  - 然后必须更换轴承（由制造商完成）。
- 在额定条件下运行20,000小时后，制造商应更换滚珠轴承。
- 若外壳脏污，使用异丙醇或类似物清洁外壳。
  - 但勿通过浸泡或喷洒方式清洁。

## 2.4.2 包装

- 采用包含Instapak泡沫垫的纸板箱包装。
  - 泡沫可通过特殊废物回收点进行回收处理。
- 您可以将塑料部件退回供应商。
  - 详见 [维修与处置](#)。

电机类型	包装	最大堆叠高度
AKME2	纸板箱	10
AKME3	纸板箱	6
AKME4	纸板箱	6
AKME5	纸板箱	5
AKME6	纸板箱	1
AKME7	纸板箱	1

## 2.4.3 维修与处置

### 2.4.3.1 维修

电机维修必须由制造商完成。

- 开启伺服电机将导致保修失效。
- 制造商接受旧伺服电机及配件的退回，以便进行专业处置。
  - 这符合 WEEE-2012/19/EU 指南的规定。
- 寄件人需承担将伺服电机退回的运输费用。

### 2.4.3.2 处置

如需处理，请将设备连同原包装一起寄往相关制造商的地址。

地区	处理地址
中国和SEA	<b>A&amp;S Industry Technology (Tianjin) Co., Ltd.</b> No. D9-1/D9-2, Saida International Industrial City Xiqing Economic & Technological District Tianjin 300385, China

## 2.4.4 储存

### 通知

- 仅可使用制造商的原始可回收包装储存。
- 气候类别1K4，符合EN 61800-2、IEC 60721-3-1。
- 湿度：5%至95%相对湿度，无冷凝。
- 最大堆叠高度：参见 [包装](#)。
- 储存温度：-25 °C 至 +55 °C，最大变化率20K/小时。
- 储存时间：无限

## 2.4.5 运输

### 通知

- 运输仅限由合格人员操作，且必须使用制造商原装可回收包装。
- 避免碰撞，特别是对轴端部位。
- 气候类别 2K3，符合 EN 61800-2、IEC 60721-3-2。
- 5%至95%相对湿度，无冷凝。
- 温度：-25 °C 至 +70 °C，最大变化率 20K/小时
- 若包装损坏，检查电机是否有可见损坏。
- 通知承运商，并在适当的情况下通知制造商。

### 2.4.5.1 20 kg 以上电机的运输

请遵循电机包装内的任何运输说明。



### 危险

悬挂负载！



- 负载坠落将造成人员死亡风险。
- 当电机提升时严禁站在负载下方。

B1/ 4 x Lifting Bolt Plus Lifting Beam

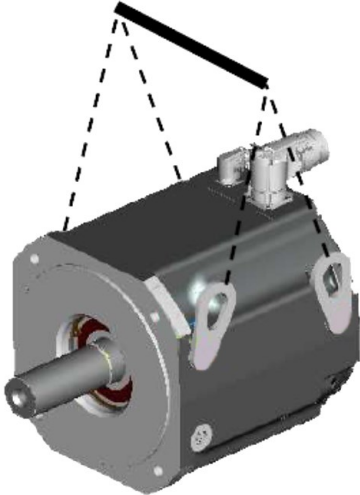

B2/ 2 x Lifting Bolt Plus Lifting Beam

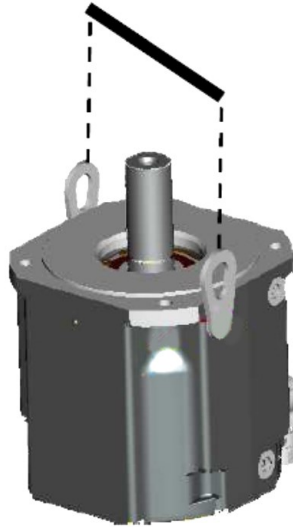

B3/ 2 x Lifting Bolt Plus Lifting Beam

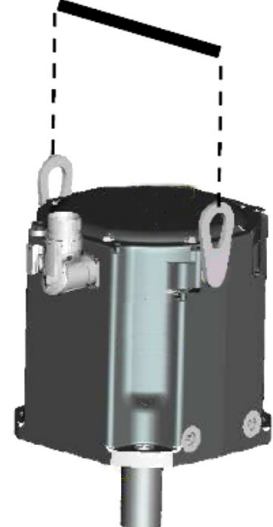

Figure 2-1: 示例：起重梁

### 2.4.5.2 吊耳

必须使用吊耳来安全运输 AKME7 电机 (> 20kg)。

- 在使用前，检查吊耳安装是否稳固以及是否有任何明显损坏迹象（腐蚀、变形）。
  - 严禁使用存在变形的起重吊具。
- 吊耳的紧固螺栓必须完全拧紧。
  - 吊耳必须平整地定位在支撑面上。
- **仅限 AKME7：** Kollmorgen 推荐使用 ZPZM 120/292 运输工具搬运伺服电机。
  - 悬挂装置 ZPZM 120/292 包括一个悬挂在起重机挂钩上的横梁以及 2 个双链悬挂器。

## 2.5 包装

### 2.5.1 包装供应

该包装内含AKME系列伺服电机。

### 2.5.2 铭牌

标准伺服电机的铭牌采用外壳侧粘贴式安装。

#### 2.5.2.1 AKME2 和 AKME3

适用于2和3号框架尺寸的标签：

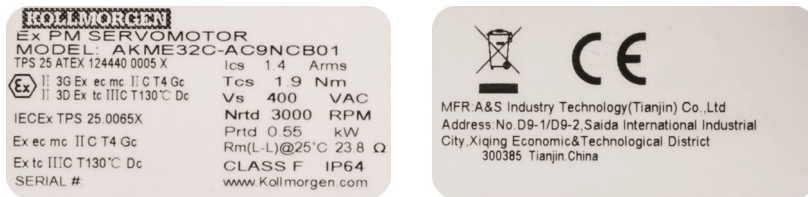

#### 2.5.2.2 AKME4 至 AKME7

适用于4至7号框架尺寸的标签：

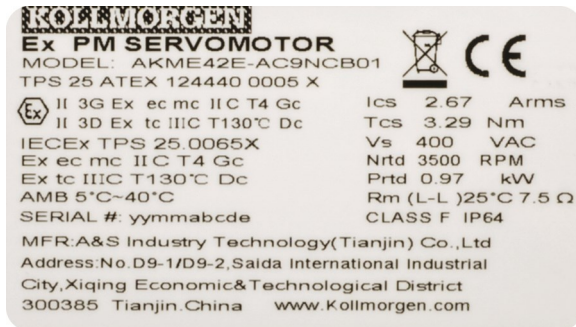

图例	说明
MODEL	伺服电机类型
Ics	连续电流
Tcs	连续转矩
Vs	直流母线电压
Nrtd	额定转速@ $U_n$
Prtd	额定功率
Rm	绕组电阻 @ 25 °C
SERIAL	序列号
AMBIENT	最高环境温度 5 °C 至 +40 °C
IPXX	防护等级
CLASS F	绝缘等级

序列号中编码了制造年份和周数。

序列号的前两位数字代表制造年份（例如25代表2025年）。

序列号的第三位和第四位数字代表制造周数（例如32代表第32周）。

## 2.6 一般技术数据

技术数据	描述
环境温度	<ul style="list-style-type: none"> <li>• 5 °C 至 +40 °C，适用于海拔高度不超过1000米（以额定值为准）。</li> <li>• 当环境温度超过40 °C或采用封装式安装伺服电机时，务必咨询科尔摩根的应用部门。</li> </ul>
滚珠轴承寿命	工作时间 ≥ 20,000 小时。
允许湿度	5%至95%相对湿度，无冷凝（在额定值下）。
功率降额（电流和转矩）	1%/°K（40 °C到50 °C，海拔 1000m 以下） 海拔高于 1000m 且温度为 40 °C 时： <ul style="list-style-type: none"> <li>• 6%（海拔 2000m 以下）</li> <li>• 17%（海拔 3000m 以下）</li> <li>• 30%（海拔 4000m 以下）</li> <li>• 55%（海拔 5000m 以下）</li> </ul> 对于温度下降率10 °K /1000m且海拔高于1000m的情形，不降额。

### 注意

请参阅各伺服电机系列章节，获取其对应的技术数据和尺寸图。

## 2.7 标准规格

---

2.7.1 反馈 .....	57
2.7.2 法兰 .....	58
2.7.3 接地螺栓 .....	58
2.7.4 抱闸 .....	59
2.7.5 防护等级 .....	61
2.7.6 绝缘材料等级 .....	61
2.7.7 轴端, A侧 .....	61
2.7.8 轴密封件 .....	62
2.7.9 安装方式 .....	62
2.7.10 表面 .....	62
2.7.11 热保护装置 .....	63
2.7.12 振动等级 .....	64

## 2.7.1 反馈

AKME伺服电机提供多种反馈编码器选项。

- 所有所需的AKME伺服电机和编码器参数均已在Kollmorgen伺服驱动器-WorkBench调试系统中预先配置。
- 当使用伺服电机与第三方伺服驱动器配合时，相关参数位于[AKME - Feedback Specifications](#)参数设置区域。
- 请联系 [Support and Services](#) 获取帮助。

### 2.7.1.1 反馈单元选项与分辨率

#### Feedback Unit Options

■ Safety Capable

Code	Designation	AKME Frame Size	Single-Turn or Multi-Turn	Feedback Resolution				
				Device Resolution (Sin/Cos per Rev., Bits or Lines/Rev.)	AKD Internal Resolution	AKD2G Internal Resolution	# of Absolute Revs.	Accuracy (± arc-mins)
2-	Commutating Encoder	2-7	Single-turn	2048 Lines	8,192	8,192	None	1
AA	BiSS B	2-7	Single-turn	2048 Sin/Cos	27-Bits	32-Bits	1	0.6
AB	Optical Sine Encoder	2-7	Multi-turn				4,096	
CB	SFD-M Smart Feedback Device, Multi-turn	2-6	Multi-turn	24-Bits	24-Bits	24-Bits	65,536	1
GU*	HIPERFACE DSL® Optical Encoder	2-6	Multi-turn	17-Bits	18-Bits	18-Bits	4,096	4
GJ	HIPERFACE Optical Sin/Cos Encoder	2-7	Single-turn	128 Sin/Cos	23-Bits	31-Bits	1	1.33
GK			Multi-turn				4,096	
DA	EnDat® 2.2/01 Optical Sine Encoder	2-4	Single-turn	512 Sin/Cos	25-Bits	32-Bits	1	1
		5-7		2048 Sin/Cos	27-Bits		0.333	
DB		2-4	Multi-turn	512 Sin/Cos	25-Bits		4,096	1
	5-7	2048 Sin/Cos		27-Bits	0.333			
R-	Resolver Inductive Encoder	2-4	Single-Turn	1 pole pair (16-Bits)	16-Bits	16-Bits	1	10
		5-7					9	

\* SICK HIPERFACE DSL® model EEM37-2KF0A017A. Please visit <https://www.sick.com> to download the latest safety data sheet.

### 2.7.1.2 反馈与连接器可用性

#### Feedback and Connector Availability

AKME2			AKME3-6			AKME7		
Feedback Code	Connector Code	4 9	Feedback Code	Connector Code	4 9	Feedback Code	Connector Code	4 W*
Feedback Code	R-	•	Feedback Code	R-	•	Feedback Code	R-	•
	2-	•		2-	•		2-	•
	AA, AB	•		AA, AB	•		AA, AB	•
	CB	•		CB	•		CB	•
	DA, DB	•		DA, DB	•		DA, DB	•
	GJ, GK	•		GJ, GK	•		GJ, GK	•
	GU	•		GU	•			

\*AKME74Q Only

## 2.7.2 法兰

IEC 法兰公差符合 DIN 42955 标准。

允许轴延伸跳动，并包括适用于旋转电机的安装法兰。

Code	Flange
A	IEC 带公差 N。
B	<ul style="list-style-type: none"> <li>NEMA</li> <li>请参阅各伺服电机系列章节，获取其对应的技术数据和尺寸图。</li> </ul>
C	替代IEC标准。
D	其他标准。
E	NEMA安装座。
G	替代IEC标准。
H	替代IEC标准。
K	替代NEMA安装座。
L	NEMA 56 安装座。

## 2.7.3 接地螺栓



AKME伺服电机配备接地螺栓，符合ATEX / IECEx接地规范。

### 2.7.3.1 接地螺栓规格

- 六角头螺钉, ISO 4017:
  - M3 X 5 (AKME2 至 AKME4)
  - M4 X 6 (AKME5 至 AKME7)
- 紧固扭矩: 0.56 Nm
- 接地线规格: 不小于4mm<sup>2</sup>

## 2.7.4 抱闸

所有伺服电机均可选配保持制动功能。

- 伺服电机内集成了弹簧抱闸 (24V<sub>DC</sub>)。
  - 当该抱闸断电时，它会锁住转子。

### 警告



保护悬挂负载！

操作该机器的人员存在受伤风险。

- 若存在悬吊负载（垂直轴），且伺服电机的保持抱闸在伺服驱动器未同时输出信号的情况下被释放，负载可能坠落！
- 用户应考虑：
  - 悬挂负载（垂直轴）时所需的当地安全标准。
  - 需要通过采取额外的安全措施来避免危险，从而确保人员安全。

### 通知

- 保持抱闸设计为静止抱闸。
  - 它们不适用于反复操作制动。
- 在频繁操作制动的情况下，保持抱闸的过早磨损和失效是可预见的。
- 安装保持抱闸时，伺服电机的长度会增加。
- 保持抱闸可由伺服驱动器直接控制。
  - **不存在人身安全风险！**
  - 参见 [Holding Brake Functionality](#)。
- 伺服驱动器中已抑制绕组效应。
  - 无需额外电路（参见伺服驱动器使用说明书）。
- 若保持抱闸未由伺服驱动器直接控制，则需额外布线（例如压敏电阻）。
  - 请联系 [Support and Services](#) 获取帮助。
- 参见 [Brakes - Technical Data](#)。

### 2.7.4.1 ATEX / IECEx 合规性保持抱闸电压要求

**通知**

为保持ATEX/IECEx T4温度等级合规性，施加的保持抱闸电压必须限制在17V<sub>DC</sub>以内。

#### 2.7.4.1.1 使用 WorkBench 设置 AKD2G 伺服驱动器的保持抱闸电压

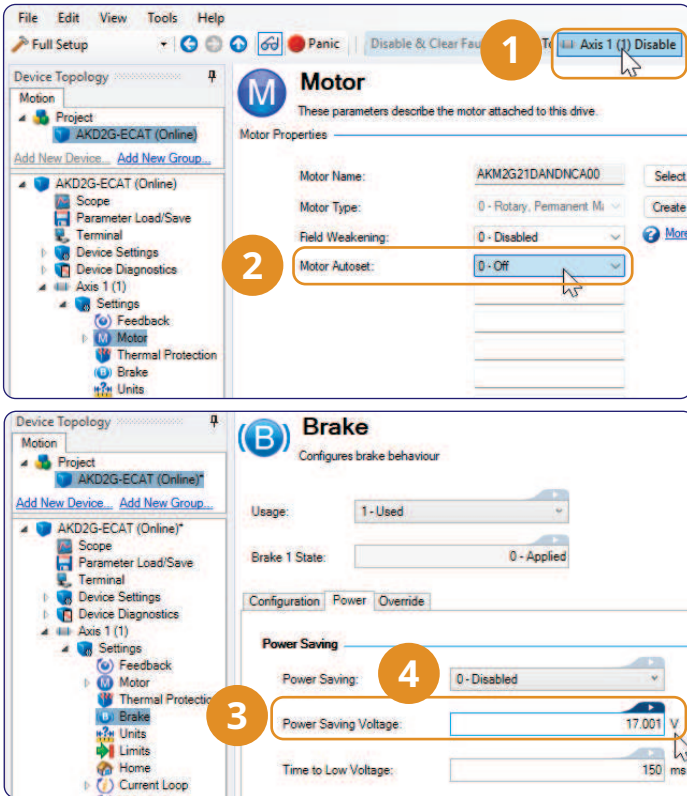

1. 禁用轴 AXISx.DIS。
2. 将 **AXISx.MOTOR.AUTOSSET** (电机自动设置) 设置为 0 (关闭)。
3. 将 **AXISx.BRAKEPOWERLOW** (节能电压) 设置为 17V<sub>DC</sub>。
4. 将 **AXISx.MOTOR.BRAKEPOWERSAVING** (节能) 设置为 1 (启用)。

#### 2.7.4.1.2 设置保持抱闸电压 - AKD、Kollmorgen Essentials 或第三方驱动器

**重要事项**

- WorkBench中的保持抱闸省电功能仅适用于 AKD2G 伺服驱动器。
- 请联系 Kollmorgen [Support and Services](#) 获取降低所有其他 AKME 伺服电机和伺服驱动器配置抱闸电压的解决方案。

## 2.7.5 防护等级

根据EN 60529标准。

防爆电机	连接器选项	轴密封件	防护等级
AKME2 - AKME7	-4, -9, -W	有	IP64

**注意**

这 [Ingress Protection of Servo Motors](#).

## 2.7.6 绝缘材料等级

伺服电机符合IEC 60085 (UL1446) F级绝缘材料标准。

## 2.7.7 轴端，A侧

电力传输通过圆柱形轴端 A 完成，该轴端适用于 EN 50347 标准中的 K6 (AKME2 至 AKME7: H7) ，带有锁定螺纹但没有安装键槽。

- 伺服电机可提供符合DIN 6885标准的键槽和插入键。
  - 带键槽的轴采用短 (半) 键。
- 轴承使用寿命为工作 20,000 小时。

订购代码	订购代码	适用电机
C	封闭键槽	AKME2 - AKME7
K	开放键槽	AKME2 - AKME7
N	无键轴	AKME2 - AKME7

### 2.7.7.1 耦合器

双锥形夹头已被证明是理想的零背隙耦合装置，并可在必要时结合使用金属波纹管耦合器。

### 2.7.7.2 最大轴向力

在将小齿轮或齿轮组装到轴上并使用角齿轮箱时，会产生轴向力。

伺服电机	AKME2	AKME3	AKME4	AKME5	AKME6	AKME7
最大轴向力 (N)	600	600	1400	1740	2200	3000

额定转速下的最大值如下: [AKME - L10 Servo Motor Bearing Fatigue](#).

### 2.7.7.3 最大径向力

若伺服电机驱动小齿轮或齿形皮带，则会产生较大的径向力。

伺服电机	AKME2	AKME3	AKME4	AKME5	AKME6	AKME7
最大径向力 (N)	150	340	500	830	1940	2300

最大径向载荷额定值基于以下假设：

- 伺服电机以该机型中最长部件的峰值扭矩进行运行。
- 在最小直径标准安装轴延伸段末端施加完全反向负载。
- 安全系数 = 2。

#### 注意

- 轴自由端中间的动力输出装置允许  $F_R$  提升 10%。
- 额定转速下的最大值如下：[AKME - L10 Servo Motor Bearing Fatigue](#)。
- 请参阅各伺服电机系列章节，获取其对应的技术数据和尺寸图。

### 2.7.8 轴密封件

若AKME伺服电机连接至具有未密封轴区域的机器法兰，则轴密封件确保轴的密封性。

- 严禁轴密封件干运转。如需干运转，请联系。
  - Kollmorgen 获取特殊的轴密封件解决方案。
- 特氟龙Teflon轴封确保轴区域达到IP67防护等级。
- 轴密封件运行数小时后可达到额定性能。
  - 无需特别的运行措施。
- 特氟龙Teflon材料出现少量剥落属于正常现象，不会影响其功能。
- 轴密封件使用 FDA 润滑脂预润滑。

### 2.7.9 安装方式

AKME伺服电机的安装方式为IM B 5型，符合EN 60034-7标准。

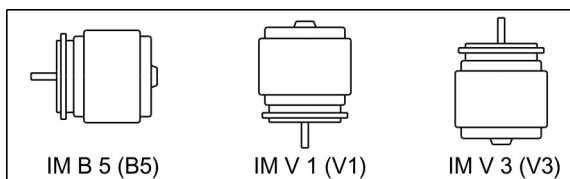

### 2.7.10 表面

- 电机带有亚光黑颜色的聚酯粉末涂层。
- 该涂层不耐溶剂（例如三氯乙烯、硝基稀释剂等）。

## 2.7.11 热保护装置

该防爆伺服电机配备 PT-1000 传感器。

- PTC不提供任何针对短时重载过载的保护。
- 通过 HIPERFACE DSL 和 SFD-M (CB) 数字反馈系统，温度传感器状态以数字方式传输并在伺服驱动器中进行评估。
- 当使用Kollmorgen配置的反馈电缆时，传感器将集成到数字伺服驱动器的监控系统中。

### 2.7.11.1 热敏元件：电阻与温度曲线

热敏器件曲线显示了与伺服电机绕组的给定温度相对应的等效电阻值（单位为欧姆）。与伺服电机配套使用的伺服驱动器必须支持所选的热保护装置，才能确保正常运行。

**重要事项**

- Kollmorgen伺服驱动器可以直接解读来自热传感器的信息，从而准确反映伺服电机绕组温度。
- 有关其他伺服驱动器，请参阅 [Delta Between Motor Winding and Thermal Device Curve](#)。

Standard

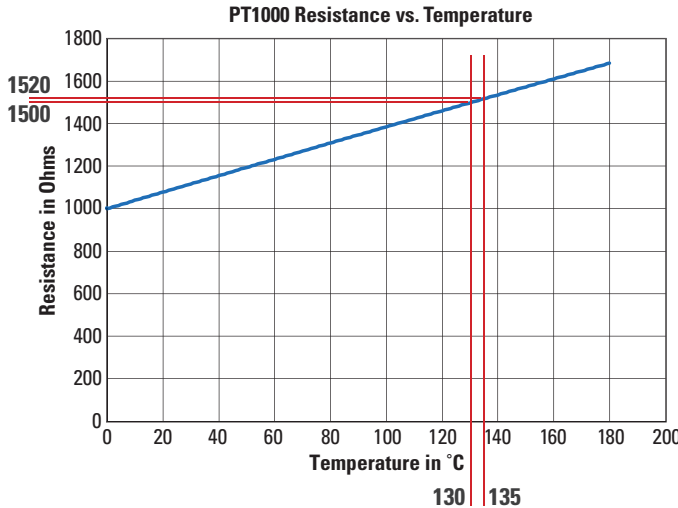

In order to maintain T4/T130°C temperature classification, the PT1000 device resistance must be limited to a range of 1500 - 1520 Ω.

### 2.7.12 振动等级

伺服电机符合EN 60034-14标准规定的A级振动等级。

对于转速范围为600RPM至3600RPM，且轴心距在56mm至132mm之间的工况，允许振动强度值为1.6mm/s。

速度[rpm]	最大相对振动位移[μm]	最大跳动[μm]
≤ 1800	90	23
> 1800	65	16

#### 2.7.12.1 振动和冲击

- 振动测试符合标准 EN 60068-2-6: 2007: 振动强度 10G / 10-2000Hz。
- 根据标准 EN 60068-2-27: 2008 进行冲击测试：冲击强度 100G / 6ms。

## 2.8 接线技术

### 2.8.1 连接器

#### 重要事项

如果使用用户定制或第三方电缆，则无法保证 Kollmorgen 伺服驱动器和电机系统的兼容性和性能。

- 有关连接器信息，请参阅 [命名规则](#)。
- 有关连接器信息，请参阅 [AKME - Connector Pinouts](#)。
- 请参阅 [AKME - Cables](#) 了解 AKME 电缆连接器引脚排列。

#### Connector Options

Code	Thermal Sensor*	Used with	IP Rating**	Connection type	Description
4	PT1000	AKME2-AKME7	IP67	2 threaded connectors, size 1.0 (M23)	Angled, rotatable, mounted on motor
9		AKME2-AKME6	IP67	1 threaded connector, size 1.0 (M23)	Angled, rotatable, mounted on motor
W		AKME7	IP67	1 feedback threaded connector, size 1.0 (M23) 1 power threaded connector, size 1.5 (M40)	Angled, rotatable, mounted on motor

\*For Thermal Device Curves, reference see the Thermal Sensor Protective Devices page.

\*\*IP ratings shown apply ONLY to the connector and the connector base/bushing on motor.

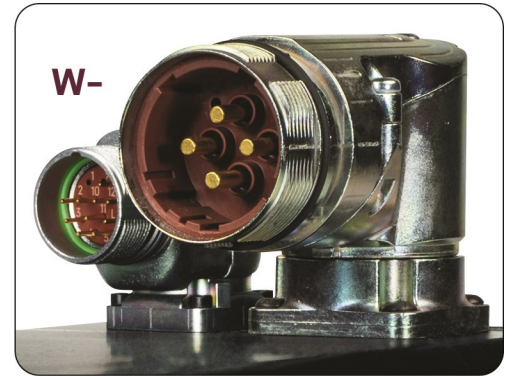

### 2.8.2 电缆连接器部件编号

AKME电机连接器	代码	电缆配套连接器部件号	制造商
M23 Power/Hybrid	4-, 9-	1605617	Phoenix
M23 Feedback 12-pin	4-, W-	1069313	Phoenix
M23 Feedback 17-pin	4-, W-	1619754	Phoenix
M40 Power	W-	CSTA-263-NN-00-26-0001-000	Intercontec

### 2.8.3 芯线截面积

- 参见KSN文章 [Hybrid Cables](#)，了解混合电缆的技术说明。
- [电源电缆](#)，[组合电缆](#)
- [反馈电缆](#)
- [混合电缆](#)

### 2.8.3.1 电源电缆，组合电缆

组合电缆包括 4 根电源芯线和 2 根用于电机抱闸控制的额外芯线。

- 括号 (...) 显示的是屏蔽层。
- 电流容量符合 EN 60204-1:2006 标准表格 6 的 B2 列

电缆	截面积 组合电缆	电流容量
(4 x 1)	(4 x 1 + (2 x 0.75))	0A < Arms ≤ 10.1A
(4 x 1.5)	(4 x 1.5 + (2 x 0.75))	10.1A < Arms ≤ 13.1A
(4 x 2.5)	(4 x 2.5 + (2 x 1))	13.1A < Arms ≤ 17.4A
(4 x 4)	(4 x 4 + (2 x 1))	17.4A < Arms ≤ 23A
(4 x 6)	(4 x 6 + (2 x 1))	23A < Arms ≤ 30A

### 2.8.3.2 反馈电缆

类型	截面积	备注
Comcoder	(8 x 2 x 0.25)	增量编码器 + 霍尔编码器
Encoder 编码器	(7 x 2 x 0.25)	BiSS, EnDat, HIPERFACE Analog
旋转变压器,	(4 x 2 x 0.25)	

### 2.8.3.3 混合电缆

- **SFD-M 及 HIPERFACE DSL:** 4条电源线、2条抱闸线和2条信号线。

类型	截面积
SFD-M 及 HIPERFACE DSL	(4 x 1.5 + (2 x 0.34) + (2 x 0.75))
SFD-M 及 HIPERFACE DSL	(4 x 2.5 + (2 x 0.34) + (2 x 1.0))
SFD-M 及 HIPERFACE DSL	(4 x 4.0 + (2 x 0.34) + (2 x 1.0))

## 2.9 机械安装

### 注意

请参阅各伺服电机系列章节，获取其对应的技术数据和尺寸图。

### 2.9.1 安装和操作条件

- 伺服电机仅可在最高4040 °C的环境温度下使用。

### 通知

- 在安装和运行过程中，应保护伺服电机免受可能导致涂漆表面出现划痕或裂纹的机械影响。
- 不当操作会增加腐蚀风险。

### 2.9.2 法兰安装



### 重要事项

仅允许具备机械工程知识的合格人员组装伺服电机。

#### 2.9.2.1 法兰安装指南

### 通知

- 防止电机受到不可接受的应力。
  - 在安装和处理期间，不得损坏任何组件。
- 现场必须没有任何导电性或腐蚀性材料。
  - 对于 V3 安装（轴端朝上），确保没有液体会进入轴承。
  - 如需封装式组件，请联系科尔摩根。
- 确认伺服电机的通风是否畅通无阻。
- 遵守允许的环境温度和法兰温度。
  - 如果环境温度高于 40 °C，请事先联系 Kollmorgen 应用部门。
  - 确认周边环境及伺服电机法兰存在充分的热传递。
- 伺服电机法兰和轴在存储和组装过程中尤其脆弱——请避免使用蛮力。
  - 必须使用提供的锁紧螺纹拧紧联轴器、齿轮轮、皮带轮，并在可行时预热驱动部件。
  - 撞击或使用外力会导致轴承和轴的损坏。

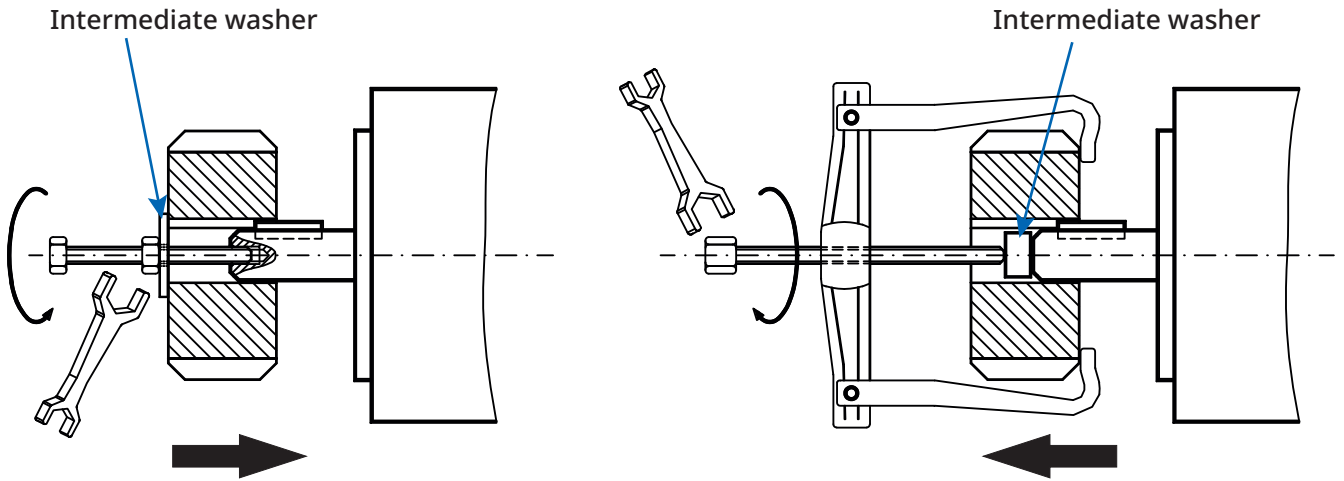

Figure 2-2: 示例：中间垫圈

**通知**

- 若可能，仅使用无背隙且通过摩擦锁定的夹头或耦合器。
  - 确保耦合器的正确对准。
  - 若有位移，将导致不可接受的振动，并损坏轴承和耦合器。
- 在任何情况下，严禁使用刚性耦合器和额外的外部轴承来进行机械受限的电机轴安装（例如在减速机中）。
- 确定伺服电机的极数和解析器的极数（如适用）。
  - 请确认所使用的伺服驱动器已设置正确。
  - 错误的设置可能导致伺服电机损坏，特别是小型伺服电机。
- 尽可能避免在伺服电机轴上施加轴向载荷。
  - 轴向载荷会显著缩短伺服电机的使用寿命。
- 检查对允许径向力和轴向力  $F_R$  和  $F_A$  的符合性。
  - 当采用齿形带传动时，小齿轮的最小允许直径由下列公式得出：  

$$d_{\min} \geq (M_0 / F_R) * 2$$

## 2.10 电气安装

**重要事项** 仅允许具备电气工程知识的合格人员组装伺服电机。



### 危险



危险电压!

- 在组装和接线过程中，务必确认伺服电机已断电。
  - 任何待连接的设备均不得通电。
- 触碰裸露触点可能会有死亡或重伤风险。
  - 确认开关柜保持关闭状态（例如设置防护栏、警示标志等）。
  - 各电压仅在设置期间重新接通。
- 存在电击风险！
  - 切勿在伺服电机通电时断开其电气连接。
  - 在不利条件下，可能产生电弧，对人员造成伤害并损坏触点。
- 驱动器电容器中的残余电荷在主电源关闭后长达10分钟内仍可能产生危险电压。
  - 即使伺服电机未旋转，控制线和电源线仍可能带电。
- 测量直流链路电压并等待其降至  $60V_{DC}$  以下。

### 注意

- 接地符号 () 表示必须提供电气连接。
  - 该连接必须在所示单元与开关柜中的安装板之间尽可能具有较大的接触面积。
  - 该符号出现在接线图中。
- 该连接旨在抑制 HF 干扰，严禁将其与 PE（保护性接地）符号  (EN 60204 标准规定的保护措施) 混淆。

### 注意

连接伺服电机时，请参照所用伺服驱动器安装手册中的接线图。

### 注意

- 电缆连接器的引脚排列如下：[AKME - Connector Pinouts](#)。
- 伺服驱动器端口的引脚排列方式详见伺服驱动器的使用说明书。

## 2.10.1 电气安装指南

1. 请确认伺服驱动器与伺服电机相互匹配。
  - a. 核对设备的额定电压和额定电流。
  - b. 请根据伺服驱动器说明书中的接线图安装线路。  
与伺服电机的连接点如下: [AKME - Connector Pinouts](#)。
2. 所有承载大电流的电缆均应按EN 60204标准安装, 并确保其截面积足够。  
请参阅各伺服电机系列章节, 获取其对应的技术数据和尺寸图。

### 注意

- 对于较长的伺服电机电缆 (>25米), 且根据所用伺服驱动器的类型, 必须在伺服电机电缆中接入伺服电机扼流圈 (3YL或3YLN) 。
  - 请参阅伺服驱动器操作手册及附件手册。
3. 请确认伺服驱动器和伺服电机已正确接地。
    - a. 请根据所用伺服驱动器的安装手册, 正确实施接地和EMC屏蔽措施。
    - b. 将安装板和伺服电机外壳接地。
  4. 若使用伺服电机电源线, 且该线缆包含集成制动控制线, 则制动控制线必须进行屏蔽处理。
    - a. 屏蔽层必须两端连接。
    - b. 请参阅伺服驱动器操作手册。

### 2.10.1.1 电缆连接

1. 尽可能将电力电缆与控制电缆分开敷设。
2. 连接反馈设备。
3. 连接伺服电机的电缆。
4. 在伺服驱动器附近安装伺服电机扼流圈（如适用）。
5. 连接抱闸（若使用）。

### 2.10.1.2 电缆材料要求 - 容量

- 伺服电机电缆：< 150 pF/m。
- 旋转变压器电缆：< 120 pF/m。

### 2.10.1.3 屏蔽

1. 将屏蔽的两端连接至屏蔽端子或 EMC 连接器。
2. 连接屏蔽的两端。
3. 通过大表面积触点（低阻抗）和金属化连接器外壳或 EMC 电缆密封套，连接所有屏蔽。

## 2.10.2 将伺服电机与预装电缆连接

#### ⚠ 重要事项

如果使用用户定制或第三方电缆，则无法保证 Kollmorgen 驱动器和电机系统的兼容性和性能。

#### ⚠ 重要事项

要保持 AKME ATEX / IECEx 合规性，必须使用 Kollmorgen 预组装电缆。

- 请按照现行标准和法规安装线路。
- 仅使用 Kollmorgen 预制屏蔽电缆进行旋转变压器和电源连接。
- 屏蔽安装不当将导致 EMC 干扰，并会对系统功能造成不利影响。
- 最大电缆长度请参见所使用的伺服驱动器的说明手册。

#### 注意

有关配置电缆的详细说明，请参见 [AKME - Cables](#)。

## 2.11 设置

### ⚠ 重要事项

仅具有广泛的电气工程设计/驱动器技术知识的专业人员才可调试伺服驱动器和电机的驱动装置。

### ⚠ 危险



高电压！

- 可能存在高达 900V<sub>DC</sub> 的致命电压。
- 存在电击风险。
  - 检查确保所有带电连接点都能避免意外接触。
  - 严禁在带电时断开电机的电气连接。
- 当主电源关闭后，驱动器的电容器上的残余电荷可能会产生危险电压长达 10 分钟之久。
  - 即使在电机未旋转时，控制和电源导线仍可能带电。
- 测量直流链路的电压并等待至其降至 60V<sub>DC</sub> 以下。

### ⚠ 小心



高温表面！

- 存在轻微烫伤风险。
  - 在运行期间，电机表面的温度可能会超过 100 °C。
- 测量伺服电机的温度。
  - 等伺服电机温度冷却到 40 °C 以下后再触摸它。

### ⚠ 小心

谨防意外移动！

- 调试期间无法规避驱动器执行意外移动。
- 确认伺服电机意外移动时，不会对人员或机器造成危险。
- 伺服电机只有在牢固安装后才能操作。
- 在运行期间以及空载运行时，必须在电机的旋转部件上安装合适的防护罩！
- 执行某项任务必须采取的安全措施取决于该任务的风险评估。

## 2.11.1 设置步骤

### 注意

- 此流程是设置的一个示例。
- 根据设备的应用不同，可能需要采取其他合适的方法。

1. 检查伺服电机的组装和方向。
2. 检查驱动器组件（离合器、减速装置、皮带轮）的安装和设置是否正确。
3. 遵循允许的径向力和轴向力要求。
4. 检查伺服电机和伺服驱动器的接线和连接情况。
5. 检查接地是否正确。
6. 对于带制动器的伺服电机：通过施加 $24V_{DC}$ （符合ATEX / IECEx标准时为 $17V_{DC}$ ）测试制动器，确认制动器解除且转子自由旋转。  
见 [ATEX / IECEx 合规性保持抱闸电压要求](#)。
7. 对于无制动器的伺服电机：检查伺服电机的转子是否能自由旋转。
8. 注意听摩擦的噪声。
9. 检查所有防止意外接触带电和运动部件的必要措施是否已实施到位。
10. 根据风险评估结果，对系统进行任何特别要求的进一步测试。
11. 根据伺服驱动器设置说明对驱动器进行调试。
12. 在多轴系统中，需对每个驱动单元（伺服驱动器和伺服电机）进行单独调试。

## 2.12 故障排除

故障可能由多种不同原因引起，具体取决于系统配置。

- 表格中列出的故障原因直接影响伺服电机。
- 控制回路行为中出现的异常现象，通常可追溯至伺服驱动器的参数设置错误。
- 相关信息可通过伺服驱动器文档及设置软件获取。
- 对于多轴系统，故障可能存在更多隐性原因。

---

2.12.1 抱闸无法使用 .....	75
2.12.2 错误信息:输出级故障 .....	75
2.12.3 错误消息:旋转变压器 .....	75
2.12.4 错误信息:伺服电机抱闸 .....	75
2.12.5 错误信息:伺服电机温度 .....	75
2.12.6 伺服电机不转动 .....	76
2.12.7 伺服电机振荡 .....	76
2.12.8 伺服电机失控 .....	76

## 2.12.1 抱闸无法使用

可能原因	纠正措施
抱闸故障。	更换伺服电机。
伺服电机轴轴向过载。	<ul style="list-style-type: none"> <li>检查并减小轴向负载。</li> <li>由于轴承已损坏，请更换伺服电机。</li> </ul>
所需的制动力矩过大。	检查尺寸。

## 2.12.2 错误信息：输出级故障

可能原因	纠正措施
伺服电机电缆发生短路或对地短路。	更换电缆。
伺服电机发生短路或接地短路。	更换伺服电机。

## 2.12.3 错误消息：旋转变压器

可能原因	纠正措施
旋转变压器电缆断裂、电缆挤压等。	检查电缆。
旋转变压器连接器未正确插接。	检查连接器。

## 2.12.4 错误信息：伺服电机抱闸

可能原因	纠正措施
伺服电机抱闸故障。	更换伺服电机。
供电电压短路导致伺服电机保持制动状态。	排除短路问题。

## 2.12.5 错误信息：伺服电机温度

可能原因	纠正措施
旋转变压器连接器松动或旋转变压器电 缆断裂。	<ul style="list-style-type: none"> <li>检查连接器。</li> <li>必要时更换旋转变压器电缆。</li> </ul>
伺服电机温度传感器已切换。	<ul style="list-style-type: none"> <li>请等待伺服电机冷却。</li> <li>调查伺服电机过热的原因。</li> </ul>

## 2.12.6 伺服电机不转动

可能原因	纠正措施
抱闸未松开。	检查抱闸控制器。
设定点导线断裂。	检查设定点导线。
驱动器被机械锁定。	检查机构。
伺服电机相序错误。	更正相序。
伺服驱动器未启用。	提供启用 (ENABLE) 信号。

## 2.12.7 伺服电机振荡

可能原因	纠正措施
旋转变压器电缆屏蔽破裂。	更换旋转变压器电缆。
伺服驱动增益过高。	使用伺服电机的默认值。

## 2.12.8 伺服电机失控

可能原因	纠正措施
伺服电机相序错误。	更正相序。

## 2.13 技术数据术语

### 注意

- 请参阅各伺服电机系列章节，获取其对应的技术数据和尺寸图。
- 所有数据都适用于40 °C环境温度和95K绕组超温。
- 额定数据在适配器法兰恒定温度 65 °C 下确定。
- 数据的容差为+/- 10%。

术语	定义
峰值电流 (脉冲电流), $I_{0max}$ [A]	<ul style="list-style-type: none"> <li>• 峰值电流 (有效正弦值) 根据伺服电机绕组的不同, 可达额定电流的数倍。</li> <li>• 实际值由所使用的驱动器的峰值电流决定。</li> </ul>
额定转矩, $M_n$ [Nm]	<ul style="list-style-type: none"> <li>• 当伺服电机在额定转速下输出额定电流时, 即可产生额定扭矩。</li> <li>• 该转矩可在额定转速连续运行 (S1) 时无限制产生。</li> </ul>
抱闸松开延时, $t_{BRH}$ [ms] / 啮合延时 $t_{BRL}$ [ms]	这 2 个常数定义使用伺服驱动器的额定电压时抱闸的响应时间。
转子转动惯量, $J$ [kg-cm <sup>2</sup> ]	<p>常数J用于衡量伺服电机的加速能力。</p> <p>示例: 在 <math>I_0</math> 时, 从 0 到 3000RPM 转速的加速时间 <math>t_b</math> 为:</p> $t_b [s] = \frac{3000 \cdot 2\pi}{M_0 \cdot 60s} \cdot \frac{m^2}{10^4 \cdot cm^2} \cdot J$ <p>其中 <math>M_0</math> 单位为 Nm, J 单位为 kg.cm<sup>2</sup>。</p>
静止电流, $I_{0rms}$ [A]	静止电流是电机在 $0 < n < 100$ RPM 转速下产生静止转矩时消耗的正弦电流有效值。
静止转矩, $M_0$ [Nm]	在转速 $0 < n < 100$ RPM 和额定温度条件下, 可以无限制保持静止转矩。
热阻, $R_{thw-a}$ [deg. C/watt]	<ul style="list-style-type: none"> <li>• 热阻是指因损耗每单位耗散能量的稳态温升测量值。</li> <li>• 该值假设伺服电机安装在铝制散热器上。</li> <li>• 请参阅各伺服电机系列章节, 获取其对应的技术数据和尺寸图。</li> </ul>
热时间常数, $t_{th}$ [min]	<ul style="list-style-type: none"> <li>• 常数 tth 定义冷电机在 <math>I_0</math> 负载下升温到 <math>0.63 \times 105</math> °K 的时间。</li> <li>• 当伺服电机承受峰值电流时, 这种温度上升发生在更短的时间内。</li> </ul>
转矩常数, $K_{Trms}$ [Nm/A]	<ul style="list-style-type: none"> <li>• 转矩常数定义了伺服电机在 1A rms 电流下产生的扭矩大小 (单位为 Nm) 。</li> <li>• 其运算关系为: <math>M = I \times K_T</math> (up to <math>I = 2 \times I_0</math>).</li> </ul>
$U_N$	额定电源电压。
$U_n$	<ul style="list-style-type: none"> <li>• 直流母线链路电压。</li> <li>• <math>U_n = \sqrt{2} \cdot U_N</math></li> </ul>

术语	定义
电压常数, $K_{E_{rms}}$ [mV/min <sup>-1</sup> ]	<ul style="list-style-type: none"><li>• 电压常数定义感应的电机 EMF, 其作为 1000RPM 转速下 2 个端子间的有效正弦值。</li><li>• 在 25 °C 时测得。</li></ul>

### 3 AKME2 - Technical Data

- All data is valid for 40 °C environmental temperature and 95K overtemperature of the winding.
- Determination of nominal data with constant temperature of adapter flange of 65 °C.
- The data can have a tolerance of +/- 10%.

---

<b>3.1 AKME2 - Dimensional Drawings</b> .....	<b>80</b>
<b>3.2 AKME2 - Dimension Data</b> .....	<b>81</b>
<b>3.3 AKME2 - Performance Data</b> .....	<b>82</b>
<b>3.4 AKME2 - Servo Motor Parameters</b> .....	<b>83</b>

### 3.1 AKME2 - Dimensional Drawings

**! IMPORTANT**

- All drawings are in principle (not scaled).
- 3D Models are available at [Kollmorgen Design Tools - 3D Models](#).

**4- connector option**

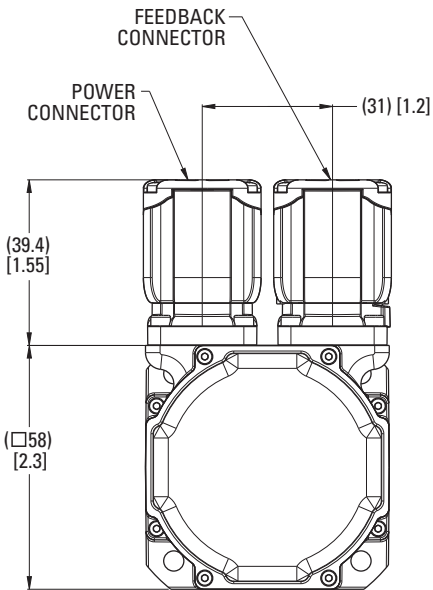
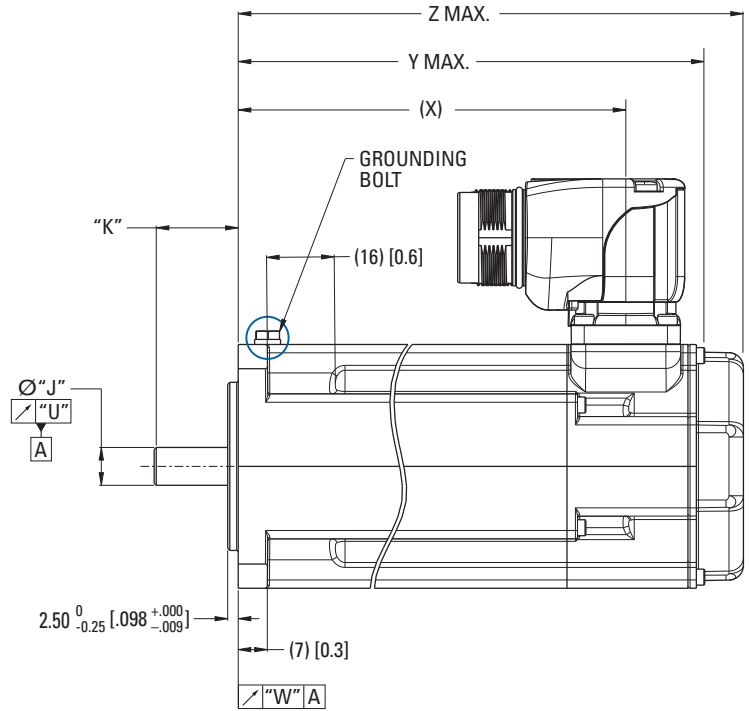
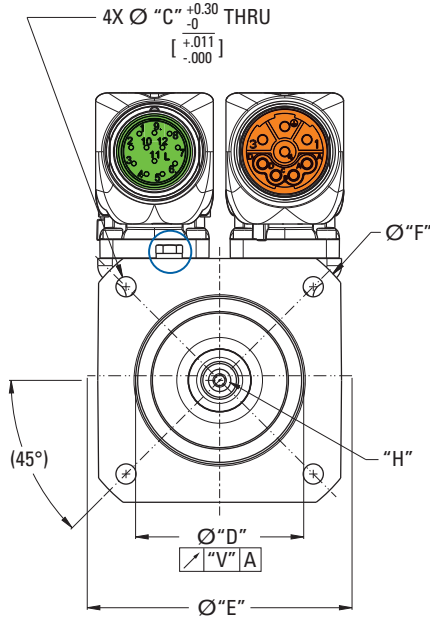

**9- connector options**

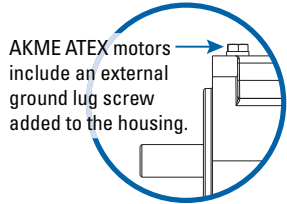
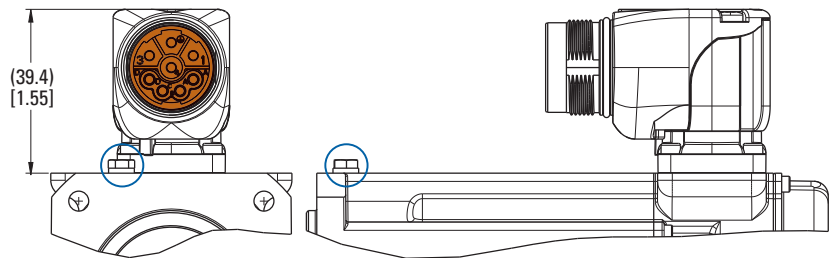

**Shaft-keyway dimensions**

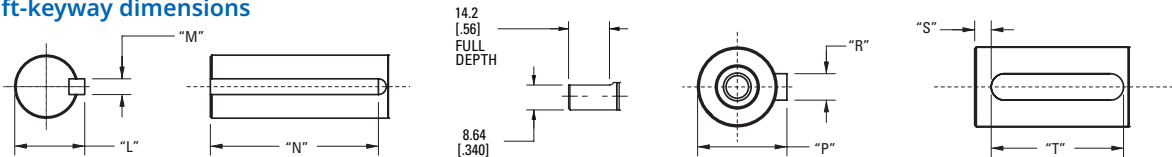

## 3.2 AKME2 - Dimension Data

### AKME2x Mounting Flange-Shaft Dimensional Data

Mounting Flange-Shaft	Hole Diameter "C"	Pilot Diameter "D"	Bolt Circle Dia. "E"	"F"	"H"	Shaft Diameter "J"	Shaft Length "K"	Shaft Dia. w/ Key "L"
AC	4.80 [0.189]	40 [1.5748]	63 [2.480]	74 [2.913]	D M3 DIN 332	9 [0.3543]	20.0 [0.79]	-
AN	4.80 [0.189]	40 [1.5748]	63 [2.480]	74 [2.913]	D M3 DIN 332	9 [0.3543]	20.0 [0.79]	-
BN	5.10 [0.201]	38.10 [1.500]	66.68 [2.625]	-	-	9.525 [0.3750]	31.75[1.250]	-
CK	5.80 [0.228]	50 [1.9685]	70 [2.756]	-	-	14 [0.5512]	30.0 [1.181]	16 [0.630]
DC	5.80 [0.228]	40 [1.5748]	65 [2.559]	-	D M3 DIN 332	9 [0.3543]	20.0 [0.79]	-
DN	5.80 [0.228]	40 [1.5748]	65 [2.559]	-	D M3 DIN 332	9 [0.3543]	20.0 [0.79]	-
EN & EF	5.10 [0.201]	38.10 [1.500]	66.68 [2.625]	-	-	9.525 [0.3750]	20.57 [0.810]	-

Mounting Flange-Shaft	Key Width "M"	Key Length "N"	Shaft Dia. w/ Key "P"	Key Width "R"	"S"	Key Length "T"	"U"	"V"	"W"
AC	-	-	10.2 [0.402]	3 [0.1181]	300 [0.118]	12 [0.472]	0.030 [0.0011]	0.060 [0.0023]	0.060 [0.0023]
AN	-	-	-	-	-	-	0.030 [0.0011]	0.060 [0.0023]	0.060 [0.0023]
BN	-	-	-	-	-	-	0.051 [0.0020]	0.10 [0.004]	0.10 [0.004]
CK	5 [0.197]	20 [0.787]	-	-	-	-	0.035 [0.0013]	0.080 [0.0031]	0.080 [0.0031]
DC	-	-	10.2 [0.402]	3 [0.1181]	300 [0.118]	12 [0.472]	0.030 [0.0011]	0.060 [0.0023]	0.060 [0.0023]
DN	-	-	-	-	-	-	0.030 [0.0011]	0.060 [0.0023]	0.060 [0.0023]
EN & EF	-	-	-	-	-	-	0.051 [0.0020]	0.10 [0.004]	0.10 [0.004]

### AKME2x Motor Length Dimensional Data

	No Brake (N)		
	X	Y MAX	Z MAX
Feedback Option	R, 2-, Ax, Dx, Gx, CB	R, 2-, Ax, Dx, CB	Gx
AKME21	76.1 [3]	95.4 [3.76]	113.4 [4.46]
AKME22	95.1 [3.74]	114.4 [4.5]	132.4 [5.21]
AKME23	114.1 [4.49]	133.4 [5.25]	151.4 [5.96]
AKME24	133.1 [5.24]	152.4 [6]	170.4 [6.71]

	Brake (2)		
	X	Z MAX	
Feedback Option	R, 2-, Ax, Dx, Gx, CB	R, 2-, Ax, Dx, CB	Gx
AKME21	76.1 [3]	129.5 [5.1]	147.1 [5.79]
AKME22	95.1 [3.74]	148.5 [5.85]	166.1 [6.54]
AKME23	114.1 [4.49]	167.5 [6.59]	185.1 [7.29]
AKME24	133.1 [5.24]	186.5 [7.34]	204.1 [8.04]

Note 1: Dimensions are in mm [inches].

Note 2: Product designed in metric. English conversions provided for reference only.

### 3.3 AKME2 - Performance Data



To maintain compliance, the rated torque, speed, and power used cannot exceed the limits set in the "IECEX - Conformity Certificate Annex" (→ p. 153).

Parameters	Tol	Symbol	Units	AKME21				AKME22				AKME23				AKME24			
				C	E	G	J	C	E	G	H	C	D	E	F	C	D	E	F
Max Rated Voltage ⑩	Max	-	Vac	240	120	-	-	400	240	120	120	400	400	240	240	400	400	240	240
			Vdc	320	160	75	75	560	320	160	160	560	560	320	320	560	560	320	320
Continuous Torque for ΔT winding = 95°C ①②⑦⑧⑨	Nom	T <sub>CS</sub>	Nm	0.42	0.44	0.44	0.38	0.78	0.8	0.81	0.82	1.06	1.08	1.09	1.11	1.30	1.33	1.33	1.34
			lb-in	3.72	3.89	3.89	3.36	6.9	7.1	7.2	7.3	9.4	9.6	9.6	9.8	11.5	11.8	11.8	11.9
Continuous Current for ΔT winding = 95°C ①②⑦⑧⑨	Nom	I <sub>CS</sub>	A <sub>RMS</sub>	1.55	3.05	4.78	6.97	1.36	2.68	4.73	5.28	1.38	2.15	2.71	4.23	1.39	2.17	2.73	3.81
Continuous Torque for ΔT winding = 60°C ②	Nom	T <sub>CS</sub>	Nm	0.336	0.352	0.352	0.304	0.62	0.64	0.65	0.66	0.85	0.86	0.87	0.89	1.04	1.06	1.06	1.07
			lb-in	2.97	3.12	3.12	2.69	5.5	5.7	5.8	5.8	7.5	7.6	7.7	7.9	9.2	9.4	9.4	9.5
Max Mechanical Speed ⑤④	Nom	N <sub>max</sub>	rpm	8000	8000	8000	8000	8000	8000	8000	8000	8000	8000	8000	8000	8000	8000	8000	8000
Peak Torque ①②	Nom	T <sub>p</sub>	Nm	1.42	1.45	1.47	1.33	2.68	2.73	2.75	2.76	3.77	3.79	3.81	3.84	4.68	4.76	4.75	4.77
			lb-in	12.6	12.8	13.0	11.8	23.7	24.2	24.3	24.4	33.4	33.5	33.7	34.0	41.4	42.1	42.0	42.2
Peak Current	Nom	I <sub>p</sub>	A <sub>RMS</sub>	6.3	12.5	19.6	28.5	5.6	11.0	19.4	21.7	5.7	8.8	11.1	17.3	5.7	8.9	11.2	15.6
48 Vdc		T <sub>rtd</sub>	Nm	-	-	-	0.33	-	-	-	0.79	-	-	-	-	-	-	-	-
			lb-in	-	-	-	2.92	-	-	-	7.0	-	-	-	-	-	-	-	-
48 Vdc		N <sub>rtd</sub>	rpm	-	-	-	4500	-	-	-	1500	-	-	-	-	-	-	-	-
48 Vdc		P <sub>rtd</sub>	kW	-	-	-	0.16	-	-	-	0.12	-	-	-	-	-	-	-	-
			Hp	-	-	-	0.215	-	-	-	0.16	-	-	-	-	-	-	-	-
75 Vdc		T <sub>rtd</sub>	Nm	-	0.41	0.40	0.33	-	0.79	0.77	0.76	-	-	-	1.07	-	-	-	1.31
			lb-in	-	3.63	3.54	2.92	-	7.0	6.8	6.70	-	-	-	9.5	-	-	-	11.6
75 Vdc		N <sub>rtd</sub>	rpm	-	2000	4000	5000	-	1000	2500	3000	-	-	-	1500	-	-	-	1000
75 Vdc		P <sub>rtd</sub>	kW	-	0.09	0.170	0.17	-	0.08	0.2	0.24	-	-	-	0.17	-	-	-	0.14
			Hp	-	0.12	0.23	0.23	-	0.11	0.27	0.32	-	-	-	0.23	-	-	-	0.19
120 Vac (160 Vdc)		T <sub>rtd</sub>	Nm	0.40	0.38	-	-	0.76	0.74	0.71	-	1.04	1.05	1.03	0.99	-	1.28	1.27	1.25
			lb-in	3.54	3.36	-	-	6.7	6.6	6.3	-	9.2	9.3	9.1	8.8	-	11.3	11.2	11.1
120 Vac (160 Vdc)		N <sub>rtd</sub>	rpm	2500	5000	-	-	1000	3500	5000	-	1000	1500	2500	4500	-	1500	2000	3000
120 Vac (160 Vdc)		P <sub>rtd</sub>	kW	0.100	0.2	-	-	0.08	0.27	0.37	-	0.11	0.16	0.27	0.47	-	0.20	0.27	0.39
			Hp	0.134	0.27	-	-	0.11	0.36	0.50	-	0.15	0.21	0.36	0.63	-	0.27	0.36	0.52
240 Vac (320 Vdc)		T <sub>rtd</sub>	Nm	0.370	-	-	-	0.71	0.7	-	-	1.00	0.95	0.96	0.97	1.24	1.20	1.17	1.19
			lb-in	3.27	-	-	-	6.3	6.20	-	-	8.9	8.4	8.5	8.6	11.0	10.6	10.4	10.5
240 Vac (320 Vdc)		N <sub>rtd</sub>	rpm	5000	-	-	-	3500	5000	-	-	2500	5000	5000	5000	2000	4000	5000	5000
240 Vac (320 Vdc)		P <sub>rtd</sub>	kW	0.190	-	-	-	0.27	0.37	-	-	0.26	0.50	0.5	0.51	0.26	0.50	0.61	0.62
			Hp	0.255	-	-	-	0.36	0.50	-	-	0.35	0.67	0.67	0.68	0.35	0.67	0.82	0.83
400 Vac (560 Vdc)		T <sub>rtd</sub>	Nm	-	-	-	-	0.70	-	-	-	0.93	0.95	-	-	1.17	1.17	-	-
			lb-in	-	-	-	-	6.2	-	-	-	8.2	8.4	-	-	10.4	10.4	-	-
400 Vac (560 Vdc)		N <sub>rtd</sub>	rpm	-	-	-	-	5000	-	-	-	5000	5000	-	-	4500	5000	-	-
400 Vac (560 Vdc)		P <sub>rtd</sub>	kW	-	-	-	-	0.37	-	-	-	0.49	0.50	-	-	0.55	0.61	-	-
			Hp	-	-	-	-	0.50	-	-	-	0.66	0.67	-	-	0.74	0.82	-	-

See following page for notes.

#### NOTE

- Motor performance across the entire speed range varies depending on the selection of feedback device and holding brake.
- The on-line [Performance Curve Generator](#) provides the most accurate information for specific models.
  - A Kollmorgen account and login is required to use this design tool.

### 3.4 AKME2 - Servo Motor Parameters

Parameters	Tol	Symbol	Units	AKME21				AKME22				AKME23				AKME24			
				C	E	G	J	C	E	G	H	C	D	E	F	C	D	E	F
Torque Constant ①	±10%	K <sub>t</sub>	Nm/A <sub>rms</sub>	0.300	0.160	0.100	0.061	0.61	0.320	0.180	0.163	0.8	0.52	0.42	0.270	0.97	0.63	0.5	0.360
			lb-in/A <sub>rms</sub>	2.70	1.4	0.9	0.54	5.4	2.8	1.6	1.44	7.1	4.6	3.7	2.4	8.6	5.6	4.4	3.2
Back EMF Constant ②	±10%	K <sub>e</sub>	V <sub>rms</sub> /krpm	19.5	10.2	6.6	3.9	39	20.4	11.7	10.5	51.8	33.8	27	17.6	62.4	40.8	32.5	23.4
Motor Constant	Nom	K <sub>m</sub>	N-m/√W	0.068	0.071	0.068	0.060	0.111	0.114	0.11	0.112	0.142	0.143	0.147	0.144	0.175	0.171	0.175	0.171
			lb-in/√W	0.601	0.625	0.602	0.53	0.986	1.01	0.98	0.99	1.26	1.27	1.3	1.28	1.55	1.52	1.55	1.52
Resistance (line-line) ③	±10%	R <sub>ℓℓ</sub>	ohm	13	3.42	1.44	0.68	20	5.2	1.77	1.4	21.2	8.8	5.4	2.34	20.4	9	5.4	2.94
Inductance (line-line)		L	mH	19	5.2	2.18	0.76	35.5	9.7	3.19	2.57	40.7	17.3	11.1	4.68	43.8	18.7	11.8	6.16
Inertia (includes Resolver feedback) ④	±10%	J <sub>m</sub>	kg-cm <sup>2</sup>	0.11				0.16				0.22				0.27			
			lb-in-s <sup>2</sup>	9.50E-05				1.40E-04				1.90E-04				2.40E-04			
Optional Brake Inertia (additional) ⑤	±10%	J <sub>m</sub>	kg-cm <sup>2</sup>	0.013				0.013				0.013				0.013			
			lb-in-s <sup>2</sup>	1.20E-05				1.20E-05				1.20E-05				1.20E-05			
Weight (w/o brake) ⑥		W	kg	0.82				1.1				1.38				1.66			
			lb	1.8				2.4				3				3.7			
Static Friction ⑦		T <sub>f</sub>	Nm	0.049				0.052				0.054				0.057			
			lb-in	0.43				0.45				0.47				0.5			
Viscous Damping ⑧		K <sub>dv</sub>	Nm/krpm	0.0046				0.0055				0.0065				0.0074			
			lb-in/krpm	0.04				0.05				0.06				0.07			
Thermal Time Constant		TCT	minutes	8				9				10				11			
Thermal Resistance		R <sub>thw-a</sub>	°C/W	1.43				1.19				1.1				1.07			
Operating Ambient Temperature Range ⑨			°C	5 to 40				5 to 40				5 to 40				5 to 40			
Pole Pairs				3				3				3				3			
Heat Sink Size				10"x10"x1/4" Aluminum Plate				10"x10"x1/4" Aluminum Plate				10"x10"x1/4" Aluminum Plate				10"x10"x1/4" Aluminum Plate			

Additional windings may exist. Please contact Kollmorgen Customer Support for further information or to request custom winding options for your application requirements.

Notes:

- ① Motor winding temperature rise, ΔT=95°C, at 40°C ambient.
- ② All data referenced to sinusoidal commutation.
- ③ Add brake inertia if applicable for total inertia.
- ④ Motor with standard heat sink.
- ⑤ May be limited at some values of V<sub>bus</sub>.
- ⑥ Measured at 25°C.
- ⑦ Brake option reduces continuous torque ratings by:  
AKME21 = 0.00 AKME22 = 0.01 Nm AKME23 = 0.02 Nm AKME24 = 0.05 Nm
- ⑧ For non-resolver feedback options: no continuous torque reduction.
- ⑨ Motors with non-resolver feedback and brake option, reduce continuous torque by:  
AKME21 = 0.00 AKME22 = 0.02 Nm AKME23 = 0.05 Nm AKME24 = 0.12 Nm
- ⑩ Brake option increases weight by 0.27 kg (0.6 lb).
- ⑪ Motors can be operated up to 400 Vac. For performances curves at voltages, listed or unlisted, please use our online Performance Curve Generator Tool.
- ⑫ Brake option will operate in this range in a non-condensing environment. See the Brake Option section for more information.
- ⑬ The applied holding brake voltage must be limited to 17 V to maintain ATEX/IECEx T4 temperature class compliance.
- ⑭ For AKME2 the maximum speed is limited up to 5000 rpm.

## 4 AKME3 - Technical Data

- All data is valid for 40 °C environmental temperature and 95K overtemperature of the winding.
- Determination of nominal data with constant temperature of adapter flange of 65 °C.
- The data can have a tolerance of +/- 10%.

---

4.1 AKME3 - Dimensional Drawings .....	85
4.2 AKME3 - Dimension Data .....	86
4.3 AKME3 - Performance Data .....	87
4.4 AKME3 - Servo Motor Parameters .....	88

## 4.1 AKME3 - Dimensional Drawings

### ! IMPORTANT

- All drawings are in principle (not scaled).
- 3D Models are available at [Kollmorgen Design Tools - 3D Models](#).

### 4- Connector Option

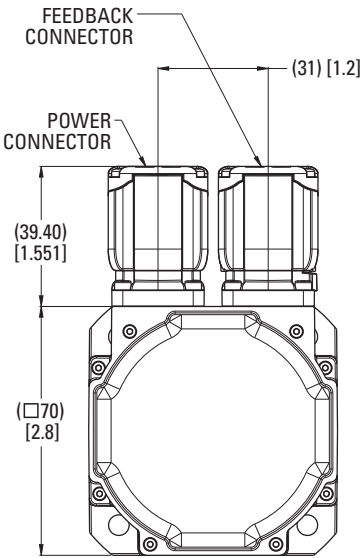
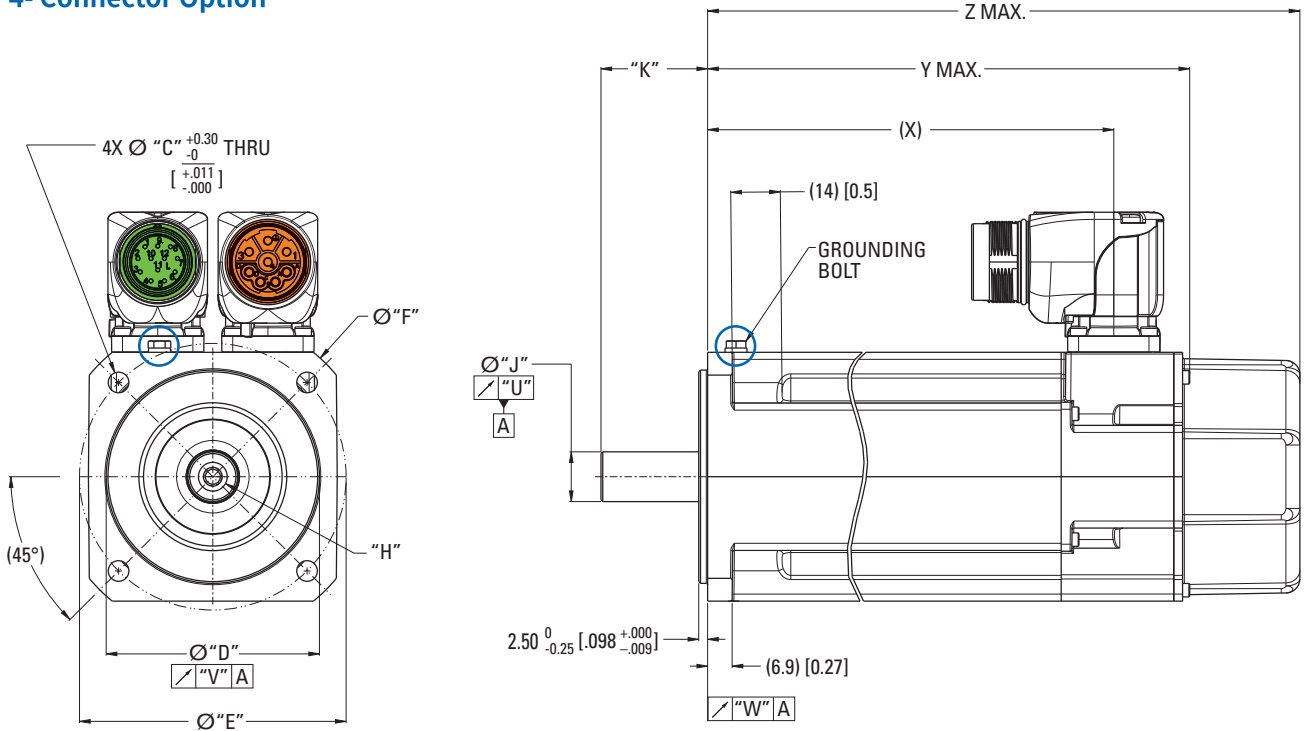

### 9- Connector Option

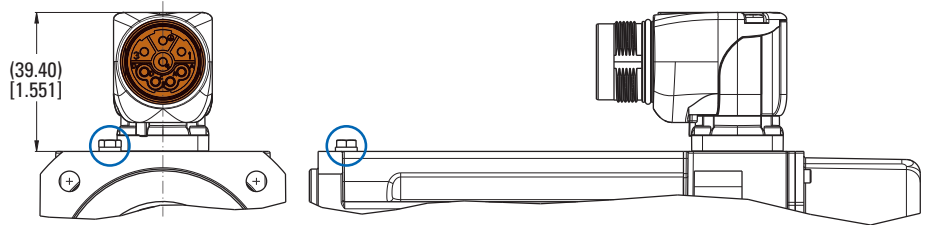

AKME ATEX motors include an external ground lug screw added to the housing.

### Shaft-keyway dimensions

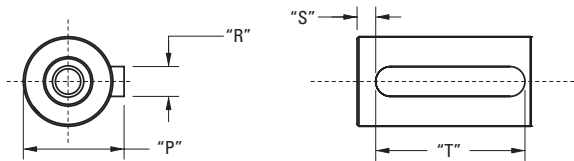

## 4.2 AKME3 - Dimension Data

### AKME3x Mounting Flange-Shaft Dimensional Data

Mounting Flange-Shaft	Hole Diameter "C"	Pilot Diameter "D"	Bolt Circle Dia. "E"	"F"	"H"	Shaft Diameter "J"	Shaft Length "K"	Shaft Dia. w/ Key "P"
AC	5.80 [0.228]	60 [2.3622]	75 [2.953]	90 [3.543]	D M5 DIN 332	14 [0.5512]	30.0 [1.181]	16 [0.630]
AN	5.80 [0.228]	60 [2.3622]	75 [2.953]	90 [3.543]	D M5 DIN 332	14 [0.5512]	30.0 [1.181]	-
CC	5.80 [0.228]	60 [2.3622]	85 [3.346]	-	D M5 DIN 332	14 [0.5512]	30.0 [1.181]	16 [0.630]
CN	5.80 [0.228]	60 [2.3622]	85 [3.346]	-	D M5 DIN 332	14 [0.5512]	30.0 [1.181]	-
GC	5.80 [0.228]	60 [2.3622]	75 [2.953]	90 [3.543]	D M5 DIN 332	11 [0.4331]	23 [0.906]	12.5 [0.492]
GN	5.80 [0.228]	60 [2.3622]	75 [2.953]	90 [3.543]	D M5 DIN 332	11 [0.4331]	23 [0.906]	-

Mounting Flange-Shaft	Key Width "R"	"S"	Key Length "T"	"U"	"V"	"W"
AC	5 [0.197]	5.00 [1.97]	20 [0.787]	0.035 [0.0013]	0.080 [0.0031]	0.080 [0.0031]
AN	-	-	-	0.035 [0.0013]	0.080 [0.0031]	0.080 [0.0031]
CC	5 [0.197]	5.00 [1.97]	20 [0.787]	0.035 [0.0013]	0.080 [0.0031]	0.080 [0.0031]
CN	-	-	-	0.035 [0.0013]	0.080 [0.0031]	0.080 [0.0031]
GC	4 [0.157]	3.5 [0.138]	16 [0.630]	0.035 [0.0013]	0.080 [0.0031]	0.080 [0.0031]
GN	-	-	-	0.035 [0.0013]	0.080 [0.0031]	0.080 [0.0031]

### AKME3x Motor Length Dimensional Data

Feedback Option	No Brake (N)		
	X	Y MAX	Z MAX
	R, 2-, Ax, Dx, Gx, CB	R, 2-, Ax, Dx, CB	Gx
AKME31	87.9 [3.46]	109.8 [4.32]	125.3 [4.93]
AKME32	118.9 [4.68]	140.8 [5.54]	156.3 [6.15]
AKME33	149.9 [5.9]	171.8 [6.76]	187.3 [7.37]

Feedback Option	Brake (2)		
	X	Z MAX	
	R, 2-, Ax, Dx, Gx, CB	R, 2-, Ax, Dx, CB	Gx
AKME31	87.9 [3.46]	141.3 [5.56]	159.3 [6.27]
AKME32	118.9 [4.68]	172.3 [6.78]	190.3 [7.49]
AKME33	149.9 [5.9]	203.3 [8]	221.3 [8.71]

Note 1: Dimensions are in mm [inches].

Note 2: Product designed in metric. English conversions provided for reference only.

### 4.3 AKME3 - Performance Data



To maintain compliance, the rated torque, speed, and power used cannot exceed the limits set in the "IECEx - Conformity Certificate Annex" (→ p. 153).

Parameters	Tol	Symbol	Units	AKME31				AKME32				AKME33		
				C	E	H	K	C	D	E	H	C	E	H
Max Rated Voltage ⑩	Max	-	Vac	400	240	120	120	400	400	400	240	400	400	240
			Vdc	560	320	160	160	560	560	560	320	560	560	320
Continuous Torque for ΔT winding = 95 °C ①②⑦⑧⑨	Nom	T <sub>CS</sub>	Nm	1.08	1.13	1.16	1.18	1.90	1.94	1.96	2.01	2.62	2.70	2.76
			Ib-in	9.6	10.0	10.3	10.4	16.8	17.2	17.3	17.8	23.2	23.9	24.4
Continuous Current for ΔT winding = 95 °C ①②⑦⑧⑨	Nom	I <sub>CS</sub>	Arms	1.33	2.90	5.68	8.81	1.40	2.17	2.74	5.34	1.43	2.51	5.42
Continuous Torque for ΔT winding = 60 °C ②	Nom	T <sub>CS</sub>	Nm	0.86	0.90	0.93	0.94	1.52	1.55	1.57	1.61	2.10	2.16	2.21
			Ib-in	7.6	8.0	8.2	8.3	13.5	13.7	13.9	14.2	18.6	19.1	19.6
Max Mechanical Speed ⑤⑩	Nom	N <sub>max</sub>	rpm	8000	8000	8000	8000	8000	8000	8000	8000	8000	8000	8000
Peak Torque ①②	Nom	T <sub>p</sub>	Nm	3.83	3.95	4.01	4.06	6.87	7.01	7.07	7.21	9.71	9.91	10.09
			Ib-in	33.9	35.0	35.5	35.9	61	62	63	64	86	88	89
Peak Current	Nom	I <sub>p</sub>	Arms	5.5	12.0	23.4	36.3	5.7	8.9	11.3	22.0	5.9	10.3	22.3
48 Vdc Rated Torque (speed) ①②⑦⑧⑨		T <sub>rtd</sub>	Nm	-	-	-	1.15	-	-	-	-	-	-	-
			Ib-in	-	-	-	10.2	-	-	-	-	-	-	-
Rated Speed		N <sub>rtd</sub>	rpm	-	-	-	2000	-	-	-	-	-	-	-
Rated Power (speed) ①②⑦⑧⑨		P <sub>rtd</sub>	kW	-	-	-	0.24	-	-	-	-	-	-	-
			Hp	-	-	-	0.32	-	-	-	-	-	-	-
75 Vdc Rated Torque (speed) ①②⑦⑧⑨		T <sub>rtd</sub>	Nm	-	1.12	1.13	1.11	-	-	-	1.96	-	-	2.69
			Ib-in	-	9.9	10.0	9.8	-	-	-	17.3	-	-	23.8
Rated Speed		N <sub>rtd</sub>	rpm	-	750	2000	3500	-	-	-	1200	-	-	800
Rated Power (speed) ①②⑦⑧⑨		P <sub>rtd</sub>	kW	-	0.09	0.24	0.41	-	-	-	0.25	-	-	0.23
			Hp	-	0.12	0.32	0.55	-	-	-	0.34	-	-	0.31
120 Vac (160 Vdc) Rated Torque (speed) ①②⑦⑧⑨		T <sub>rtd</sub>	Nm	-	1.10	0.99	1.01	-	1.91	1.92	1.87	-	-	2.53
			Ib-in	-	9.7	8.8	8.90	-	16.9	17.0	16.5	-	-	22.4
Rated Speed		N <sub>rtd</sub>	rpm	-	2500	5000	5000	-	1000	1000	3000	-	-	2500
Rated Power (speed) ①②⑦⑧⑨		P <sub>rtd</sub>	kW	-	0.29	0.52	0.53	-	0.20	0.20	0.59	-	-	0.66
			Hp	-	0.39	0.70	0.71	-	0.27	0.27	0.79	-	-	0.89
240 Vac (320 Vdc) Rated Torque (speed) ①②⑦⑧⑨		T <sub>rtd</sub>	Nm	1.05	0.96	-	-	1.85	1.83	1.82	1.68	2.55	2.53	2.21
			Ib-in	9.3	8.5	-	-	16.4	16.2	16.1	14.9	22.6	22.4	19.6
Rated Speed		N <sub>rtd</sub>	rpm	2500	5000	-	-	1500	2500	3000	5000	1000	2000	5000
Rated Power (speed) ①②⑦⑧⑨		P <sub>rtd</sub>	kW	0.27	0.50	-	-	0.29	0.48	0.57	0.88	0.27	0.53	1.16
			Hp	0.36	0.67	-	-	0.39	0.64	0.76	1.18	0.36	0.71	1.56
400 Vac (560 Vdc) Rated Torque (speed) ①②⑦⑧⑨		T <sub>rtd</sub>	Nm	0.92	-	-	-	1.76	1.62	1.63	-	2.45	2.23	-
			Ib-in	8.1	-	-	-	15.6	14.3	14.4	-	21.7	19.7	-
Rated Speed		N <sub>rtd</sub>	rpm	5000	-	-	-	3000	5000	5000	-	2000	4500	-
Rated Power (speed) ①②⑦⑧⑨		P <sub>rtd</sub>	kW	0.48	-	-	-	0.55	0.85	0.85	-	0.51	1.05	-
			Hp	0.64	-	-	-	0.74	1.14	1.14	-	0.68	1.41	-

**NOTE**

- Motor performance across the entire speed range varies depending on the selection of feedback device and holding brake.
- The on-line [Performance Curve Generator](#) provides the most accurate information for specific models.
  - A Kollmorgen account and login is required to use this design tool.

## 4.4 AKME3 - Servo Motor Parameters

Parameters	Tol	Symbol	Units	AKME31				AKME32				AKME33		
				C	E	H	K	C	D	E	H	C	E	H
Torque Constant ①	±10%	$K_t$	Nm/A <sub>rms</sub>	0.85	0.41	0.21	0.14	1.4	0.92	0.73	0.39	1.86	1.1	0.52
			lb-in/A <sub>rms</sub>	7.5	3.6	1.9	1.24	12.4	8.1	6.5	3.5	16.5	9.7	4.6
Back EMF Constant ②	±10%	$K_e$	V <sub>rms</sub> /krpm	54.5	26.1	13.7	8.98	89.8	59	47.1	24.8	120	70.6	33.4
Motor Constant	Nom	$K_m$	N-m/√W	0.15	0.154	0.151	0.156	0.235	0.232	0.237	0.245	0.295	0.299	0.303
			lb-in/√W	1.33	1.36	1.34	0.75	2.08	2.05	2.1	2.17	2.61	2.65	2.68
Resistance (line-line) ⑥	±10%	$R_m$	ohm	21.4	4.74	1.29	0.54	23.8	9.7	6.3	1.69	26.6	9	1.96
Inductance (line-line)		L	mH	37.5	8.6	2.4	1.02	46.5	20.1	12.8	3.5	53.6	18.5	4.1
Inertia (includes Resolver feedback) ③	±10%	$J_m$	kg-cm <sup>2</sup>	0.33				0.59				0.85		
			lb-in-s <sup>2</sup>	2.90E-04				5.20E-04				7.50E-04		
Optional Brake Inertia (additional) ④	±10%	$J_m$	kg-cm <sup>2</sup>	0.014				0.014				0.014		
			lb-in-s <sup>2</sup>	1.20E-05				1.20E-05				1.20E-05		
Weight (w/o brake) ⑤		W	kg	1.55				2.23				2.9		
			lb	3.4				4.9				6.4		
Static Friction ①		$T_f$	Nm	0.061				0.067				0.073		
			lb-in	0.53				0.59				0.64		
Viscous Damping ①		$K_{dv}$	Nm/krpm	0.002				0.003				0.004		
			lb-in/krpm	0.02				0.03				0.04		
Thermal Time Constant		TCT	minutes	14				17				20		
Thermal Resistance		$R_{thw-a}$	°C/W	1.11				0.92				0.78		
Operating Ambient Temperature Range ⑩⑪			°C	5 to 40				5 to 40				5 to 40		
Pole Pairs				4				4				4		
Heat Sink Size				10"x10"x1/4" Aluminum Plate				10"x10"x1/4" Aluminum Plate				10"x10"x1/4" Aluminum Plate		

Additional windings may exist. Please contact Kollmorgen Customer Support for further information or to request custom winding options for your application requirements.

### Notes:

- ① Motor winding temperature rise,  $\Delta T = 95\text{ }^\circ\text{C}$ , at  $40\text{ }^\circ\text{C}$  ambient.
- ② All data referenced to sinusoidal commutation.
- ③ Add parking brake if applicable for total inertia.
- ④ Motor with standard heat sink.
- ⑤ May be limited at some values of  $V_{bus}$ .
- ⑥ Measured at  $25\text{ }^\circ\text{C}$ .
- ⑦ Brake option reduces continuous torque ratings by:  
AKME31 = 0.0 Nm AKME32 = 0.05 Nm AKME33 = 0.1 Nm
- ⑧ For non-resolver feedback options: no continuous torque reduction.
- ⑨ Motors with non-resolver feedback and brake option, reduce continuous torque by:  
AKME31 = 0.0 Nm AKME32 = 0.1 Nm AKME33 = 0.2 Nm
- ⑩ Brake option increases weight by 0.36 kg (0.79 lb).
- ⑪ Motors can be operated up to 400 Vac. For performances curves at voltages, listed or unlisted, please use our online Performance Curve Generator Tool.
- ⑫ Brake option will operate in this range in a non-condensing environment. See the Brake Option section for more information.
- ⑬ The applied holding brake voltage must be limited to 17 V to maintain ATEX/IECEx T4 temperature class compliance.
- ⑭ For AKME3 the maximum speed is limited up to 5000 rpm.

## 5 AKME4 - Technical Data

- All data is valid for 40 °C environmental temperature and 95K overtemperature of the winding.
- Determination of nominal data with constant temperature of adapter flange of 65 °C.
- The data can have a tolerance of +/- 10%.

---

5.1 AKME4 - Dimensional Drawings .....	90
5.2 AKME4 - Dimension Data .....	91
5.3 AKME41 and AKME42 - Performance Data .....	92
5.4 AKME41 and AKME42 - Servo Motor Parameters .....	93
5.5 AKME43 and AKME44 - Performance Data .....	94
5.6 AKME43 and AKME44 - Servo Motor Parameters .....	95

## 5.1 AKME4 - Dimensional Drawings

### ! IMPORTANT

- All drawings are in principle (not scaled).
- 3D Models are available at [Kollmorgen Design Tools - 3D Models](#).

### 4- Connector Option

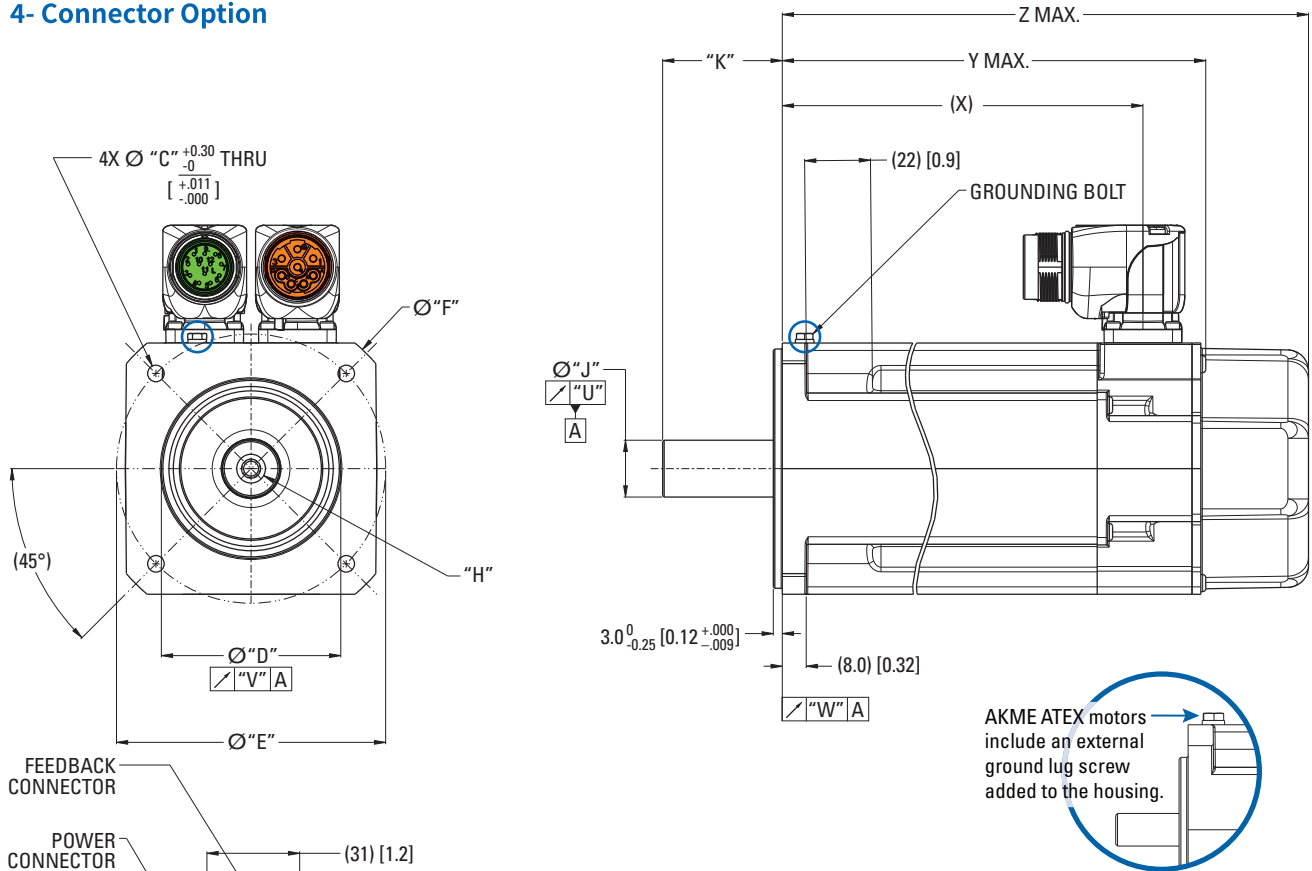

### 9- Connector Option

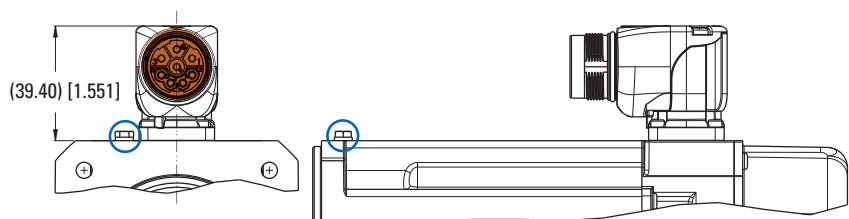

### Shaft-keyway dimensions

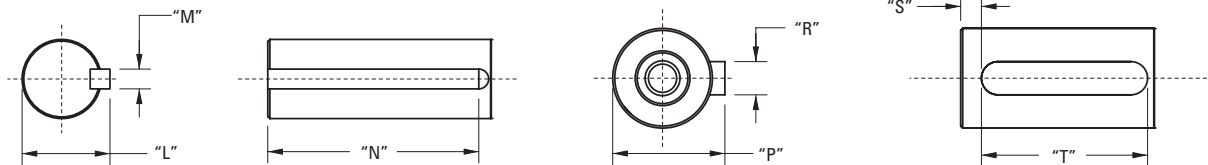

## 5.2 AKME4 - Dimension Data

### AKME4x Mounting Flange-Shaft Dimensional Data

Mounting Flange-Shaft	Hole Diameter "C"	Pilot Diameter "D"	Bolt Circle Dia. "E"	"F"	"H"	Shaft Diameter "J"	Shaft Length "K"	Shaft Dia. w/ Key "L"
AC	7 [0.276]	80 [3.1496]	100 [3.937]	-	D M5 DIN 332	19 [0.7480]	40.0 [1.57]	-
AN	7 0[0.276]	80 [3.1496]	100 [3.937]	-	D M5 DIN 332	19 [0.7480]	40.0 [1.57]	-
BK	5.54 [0.218]	73.025 [2.8750]	98.43 [3.875]	-	-	15.875 [0.6250]	52.40 [2.063]	17.92 [0.706]
CC	5.54 [0.218]	60 [2.3622]	90 [3.543]	109 [4.291]	D M5 DIN 332	19 [0.7480]	40.0 [1.57]	-
CN	5.54 [0.218]	60 [2.3622]	90 [3.543]	109 [4.291]	D M5 DIN 332	19 [0.7480]	40.0 [1.57]	-
EK	5.54 [0.218]	73.025 [2.8750]	98.43 [3.875]	-	-	12.7 [0.5000]	31.75 [1.250]	14.09 [0.555]
GC	7 [0.276]	80 [3.1496]	100 [3.937]	-	D M5 DIN 332	14 [0.5512]	30 [1.18]	-
GN	7 [0.276]	80 [3.1496]	100 [3.937]	-	D M5 DIN 332	14 [0.5512]	30 [1.18]	-
HC	5.54 [0.218]	60 [2.3622]	90 [3.543]	109 [4.291]	D M5 DIN 332	14 [0.5512]	30 [1.18]	-
HN	5.54 [0.218]	60 [2.3622]	90 [3.543]	109 [4.291]	D M5 DIN 332	14 [0.5512]	30 [1.18]	-
KK	7 [0.276]	70 [2.7559]	90 [3.543]	109 [4.291]	-	16 [0.6299]	40.0 [1.57]	-

Mounting Flange-Shaft	Key Width "M"	Key Length "N"	Shaft Dia. w/ Key "P"	Key Width "R"	"S"	Key Length "T"	"U"	"V"	"W"
AC	-	-	21.5 [0.846]	6 [0.236]	4.00 [1.57]	32 [1.260]	0.040 [0.0015]	0.080 [0.0031]	0.080 [0.0031]
AN	-	-	-	-	-	-	0.040 [0.0015]	0.080 [0.0031]	0.080 [0.0031]
BK	4.762 [0.1875]	34.93 [1.375]	-	-	-	-	0.051 [0.0020]	0.10 [0.004]	0.10 [0.004]
CC	-	-	21.5 [0.846]	6 [0.236]	4.00 [1.57]	32 [1.260]	0.040 [0.0015]	0.080 [0.0031]	0.080 [0.0031]
CN	-	-	-	-	-	-	0.040 [0.0015]	0.080 [0.0031]	0.080 [0.0031]
EK	3.175 [0.1250]	19.05 [0.750]	-	-	-	-	0.051 [0.0020]	0.10 [0.004]	0.10 [0.004]
GC	-	-	16 [0.630]	5 [0.197]	6.00 [0.236]	20 [0.787]	0.040 [0.0015]	0.080 [0.0031]	0.080 [0.0031]
GN	-	-	-	-	-	-	0.040 [0.0015]	0.080 [0.0031]	0.080 [0.0031]
HC	-	-	16 [0.630]	5 [0.197]	6.00 [0.236]	20 [0.787]	0.040 [0.0015]	0.080 [0.0031]	0.080 [0.0031]
HN	-	-	-	-	-	-	0.040 [0.0015]	0.080 [0.0031]	0.080 [0.0031]
KK	5 [0.197]	30 [1.811]	-	-	-	-	0.051 [0.0020]	0.008 [0.0031]	0.008 [0.0031]

### AKME4x Motor Length Dimensional Data

Feedback Option	No Brake (N)		
	X	Y MAX	Z MAX
	R, 2-, Ax, Dx, Gx, CB	R, 2-, Ax, Dx, CB	Gx
AKME41	96.4 [3.8]	118.8 [4.68]	136.8 [5.39]
AKME42	125.4 [4.94]	147.8 [5.82]	165.8 [6.53]
AKME43	154.4 [6.08]	176.8 [6.96]	194.8 [7.67]
AKME44	183.4 [7.22]	205.8 [8.1]	223.8 [8.81]

Feedback Option	Brake (2)		
	X	Z MAX	
	R, 2-, Ax, Dx, Gx, CB	R, 2-, Ax, Dx, CB	Gx
AKME41	96.4 [3.8]	152.3 [6]	170.3 [6.7]
AKME42	125.4 [4.94]	181.3 [7.14]	199.3 [7.85]
AKME43	154.4 [6.08]	210.3 [8.28]	228.3 [8.99]
AKME43	183.4 [7.22]	239.3 [9.42]	257.3 [10.13]

Note 1: Dimensions are in mm [inches].

Note 2: Product designed in metric. English conversions provided for reference only.

### 5.3 AKME41 and AKME42 - Performance Data



To maintain compliance, the rated torque, speed, and power used cannot exceed the limits set in the "IECEX - Conformity Certificate Annex" (→ p. 153).

Parameters	Tol	Sym	Units	AKME41			AKME42				
				C	E	H	C	E	G	H	J
Max Rated Voltage ⑩	Max	-	Vac	400	400	240	400	400	400	120	240
			Vdc	560	560	320	560	560	560	160	320
Continuous Torque for ΔT winding = 95°C ①②⑦⑧⑨	Nom	T <sub>CS</sub>	Nm	1.84	1.90	1.94	3.20	3.28	3.38	3.41	3.44
			Ib-in	16.3	16.8	17.2	28.3	29.0	29.9	30.2	30.4
Continuous Current for ΔT winding = 95°C ①②⑦⑧⑨	Nom	I <sub>CS</sub>	A <sub>RMS</sub>	1.42	2.78	5.45	1.37	2.67	4.68	5.9	8.2
Continuous Torque for ΔT winding = 60°C ②	Nom	T <sub>CS</sub>	Nm	1.47	1.52	1.55	2.56	2.62	2.70	2.73	2.75
			Ib-in	13.0	13.5	13.7	22.70	23.2	23.9	24.2	24.3
Max Mechanical Speed ⑩	Nom	N <sub>max</sub>	rpm	6,000	6,000	6,000	6,000	6,000	6,000	6,000	6,000
Peak Torque ①②	Nom	T <sub>p</sub>	Nm	6.1	6.2	6.3	11.0	11.2	11.40	11.5	11.6
			Ib-in	54	55	56	97	99	101	102	103
Peak Current	Nom	I <sub>p</sub>	A <sub>RMS</sub>	5.8	11.4	22.4	5.6	11.0	19.2	24.0	33.7
75 Vdc Rated Torque (speed) ①②⑦⑧⑨		T <sub>rtd</sub>	Nm	-	-	1.87	-	-	-	-	3.25
			Ib-in	-	-	16.5	-	-	-	-	28.8
Rated Speed		N <sub>rtd</sub>	rpm	-	-	1,000	-	-	-	1,000	
Rated Power (speed) ①②⑦⑧⑨		P <sub>rtd</sub>	kW	-	-	0.20	-	-	-	-	0.34
			Hp	-	-	0.27	-	-	-	-	0.46
120 Vac (160 Vdc) Rated Torque (speed) ①②⑦⑧⑨		T <sub>rtd</sub>	Nm	-	1.82	1.74	-	-	3.10	3.05	2.88
			Ib-in	-	16.1	15.4	-	-	27.4	27.0	25.5
Rated Speed		N <sub>rtd</sub>	rpm	-	1,200	3,000	-	-	1,500	2,000	3,000
Rated Power (speed) ①②⑦⑧⑨		P <sub>rtd</sub>	kW	-	0.23	0.55	-	-	0.49	0.64	0.90
			Hp	-	0.31	0.74	-	-	0.65	0.86	1.21
240 Vac (320 Vdc) Rated Torque (speed) ①②⑦⑧⑨		T <sub>rtd</sub>	Nm	1.76	1.70	1.64	-	2.97	2.73	-	2.57
			Ib-in	15.6	15	14.5	-	26.3	24.2	-	22.7
Rated Speed		N <sub>rtd</sub>	rpm	1,200	3,000	4,500	-	1,800	3,500	-	4,500
Rated Power (speed) ①②⑦⑧⑨		P <sub>rtd</sub>	kW	0.22	0.53	0.77	-	0.56	1.00	-	1.21
			Hp	0.30	0.71	1.04	-	0.75	1.34	-	1.62
400 Vac (560 Vdc) Rated Torque (speed) ①②⑦⑧⑨		T <sub>rtd</sub>	Nm	1.64	1.60	-	2.94	2.65	2.52	-	-
			Ib-in	14.5	14.2	-	26.0	23.5	22.3	-	-
Rated Speed		N <sub>rtd</sub>	rpm	3,000	4,500	-	1,500	3,500	4,500	-	-
Rated Power (speed) ①②⑦⑧⑨		P <sub>rtd</sub>	kW	0.52	0.75	-	0.46	0.97	1.19	-	-
			Hp	0.70	1.01	-	0.62	1.30	1.59	-	-

See following page for notes.

#### NOTE

- Motor performance across the entire speed range varies depending on the selection of feedback device and holding brake.
- The on-line [Performance Curve Generator](#) provides the most accurate information for specific models.
  - A Kollmorgen account and login is required to use this design tool.

## 5.4 AKME41 and AKME42 - Servo Motor Parameters

Parameters	Tol	Sym	Units	AKME41			AKME42				
				C	E	H	C	E	G	H	J
Torque Constant ①	±10%	K <sub>t</sub>	Nm/A <sub>rms</sub>	1.34	0.71	0.37	2.39	1.26	0.74	0.59	0.43
			lb-in/A <sub>rms</sub>	11.9	6.3	3.3	21.2	11.2	6.5	5.2	3.8
Back EMF Constant ②	±10%	K <sub>e</sub>	V <sub>rms</sub> /krpm	86.3	45.6	23.7	154	80.9	47.5	38.3	27.5
Motor Constant	Nom	K <sub>m</sub>	N-m/√W	0.237	0.236	0.242	0.374	0.369	0.381	0.375	0.393
			lb-in/√W	2.1	2.09	2.14	3.31	3.26	3.37	3.31	3.47
Resistance (line-line) ⑥	±10%	R <sub>m</sub>	ohm	21.3	6	1.56	27.5	7.5	2.51	1.65	0.8
Inductance (line-line)		L	mH	66.1	18.4	5	97.4	26.8	9.2	6	3.1
Inertia (includes Resolver feedback) ③	±10%	J <sub>m</sub>	kg-cm <sup>2</sup>	0.81			1.5				
			lb-in-s <sup>2</sup>	7.20E-04			1.30E-03				
Optional Brake Inertia (additional) ⑧	±10%	J <sub>m</sub>	kg-cm <sup>2</sup>	0.058			0.058				
			lb-in-s <sup>2</sup>	5.10E-05			5.10E-05				
Weight (w/o brake) ⑩		W	kg	2.44			3.39				
			lb	5.4			7.5				
Static Friction ①		T <sub>f</sub>	Nm	0.085			0.097				
			lb-in	0.75			0.86				
Viscous Damping ①		K <sub>dv</sub>	Nm/krpm	0.009			0.013				
			lb-in/krpm	0.08			0.12				
Thermal Time Constant		TCT	minutes	13			17				
Thermal Resistance		R <sub>thw-a</sub>	°C/W	0.97			0.8				
Operating Ambient Temperature Range ⑫⑬			°C	5 to 40			5 to 40				
Pole Pairs				5			5				
Heat Sink Size				10"x10"x1/4" Aluminum Plate			10"x10"x1/4" Aluminum Plate				

Additional windings may exist. Please contact Kollmorgen Customer Support for further information or to request custom winding options for your application requirements.

Notes:

- ① Motor winding temperature rise, ΔT=95°C, at 40°C ambient.
- ② All data referenced to sinusoidal commutation.
- ③ Add parking brake if applicable for total inertia.
- ④ Motor with standard heat sink.
- ⑤ May be limited at some values of V<sub>bus</sub>.
- ⑥ Measured at 25°C.
- ⑦ Brake motor option reduces continuous torque ratings by 0.12 Nm.
- ⑧ Non-Resolver feedback options reduces continuous ratings by:  
AKME41 = 0.1 Nm AKME42 = 0.1 Nm AKME43 = 0.2 Nm AKME44 = 0.3 Nm
- ⑨ Motors with non-resolver feedback and brake option, reduce continuous torque by:  
AKME41 = 0.22 Nm AKME42 = 0.36 Nm AKME43 = 0.55 Nm AKME44 = 0.76 Nm
- ⑩ Brake option increases weight by 0.69 kg (1.52 lb).
- ⑪ Motors can be operated up to 400 Vac. For performances curves at voltages, listed or unlisted, please use our online Performance Curve Generator Tool.
- ⑫ Brake option will operate in this range in a non-condensing environment. See the Brake Option section for more information.
- ⑬ The applied holding brake voltage must be limited to 17 V to maintain ATEX/IECEx T4 temperature class compliance.
- ⑭ For AKME4 the maximum speed is limited up to 4500 rpm.

## 5.5 AKME43 and AKME44 - Performance Data



To maintain compliance, the rated torque, speed, and power used cannot exceed the limits set in the "IECEX - Conformity Certificate Annex" (→ p. 153).

Parameters	Tol	Sym	Units	AKME43					AKME44				
				E	G	H	K	L	E	G	H	J	K
Max Rated Voltage ⑩	Max	-	Vac	400	400	400	240	240	400	400	400	400	240
			Vdc	560	560	560	320	320	560	560	560	560	320
Continuous Torque for ΔT winding = 95°C ①②⑦⑧⑨	Nom	T <sub>Cs</sub>	Nm	4.56	4.64	4.66	4.74	4.57	5.6	5.7	5.7	5.8	5.7
			lb-in	40.4	41.1	41.2	41.9	40.4	49.6	51	51	52	50
Continuous Current for ΔT winding = 95°C ①②⑦⑧⑨	Nom	I <sub>Cs</sub>	A <sub>Rms</sub>	2.69	4.74	5.3	9.3	10.9	2.78	4.87	5.5	8.6	9.8
Continuous Torque for ΔT winding = 60°C ②	Nom	T <sub>Cs</sub>	Nm	3.65	3.71	3.73	3.79	3.66	4.49	4.58	4.57	4.64	4.56
			lb-in	32.3	32.8	33.0	33.5	32.4	39.7	40.5	40.4	41.1	40.4
Max Mechanical Speed ⑥	Nom	N <sub>max</sub>	rpm	6,000	6,000	6,000	6,000	6,000	6,000	6,000	6,000	6,000	6,000
Peak Torque ①②	Nom	T <sub>p</sub>	Nm	15.8	16.1	16.1	16.3	15.9	19.9	20.2	20.2	20.4	20.1
			lb-in	140	142	142	144	141	176	179	179	181	178
Peak Current	Nom	I <sub>p</sub>	A <sub>Rms</sub>	11.0	19.5	21.8	38.3	44.6	11.4	20.00	22.5	35.2	40.4
75 Vdc Rated Torque (speed) ①②⑦⑧⑨		T <sub>rtd</sub>	Nm	-	-	-	4.59	4.25	-	-	-	5.56	5.22
			lb-in	-	-	-	40.6	37.6	-	-	-	49.2	46.2
Rated Speed		N <sub>rtd</sub>	rpm	-	-	-	500	1,000	-	-	-	500	1,000
Rated Power (speed) ①②⑦⑧⑨		P <sub>rtd</sub>	kW	-	-	-	0.24	0.45	-	-	-	0.29	0.55
			Hp	-	-	-	0.32	0.60	-	-	-	0.39	0.74
120 Vac (160 Vdc) Rated Torque (speed) ①②⑦⑧⑨		T <sub>rtd</sub>	Nm	-	4.31	4.17	3.89	3.59	-	5.5	5.23	4.78	4.68
			lb-in	-	38.1	36.9	34.4	31.8	-	48.7	46.3	42.3	41.4
Rated Speed		N <sub>rtd</sub>	rpm	-	1,000	1,500	2,500	3,000	-	500	1,000	2,000	2,000
Rated Power (speed) ①②⑦⑧⑨		P <sub>rtd</sub>	kW	-	0.45	0.66	1.02	1.13	-	0.29	0.55	1.00	0.98
			Hp	-	0.61	0.87	1.37	1.52	-	0.38	0.74	1.34	1.31
240 Vac (320 Vdc) Rated Torque (speed) ①②⑦⑧⑨		T <sub>rtd</sub>	Nm	4.08	3.80	3.66	3.07	2.96	5.0	4.70	4.43	3.55	3.17
			lb-in	36.12	33.6	32.4	27.2	26.2	44.3	41.6	39.2	31.4	28.1
Rated Speed		N <sub>rtd</sub>	rpm	1,500	2,500	3,000	4,500	4,500	1,200	2,000	2,500	4,000	4,500
Rated Power (speed) ①②⑦⑧⑨		P <sub>rtd</sub>	kW	0.64	0.99	1.15	1.45	1.39	0.63	0.98	1.16	1.49	1.49
			Hp	0.86	1.33	1.54	1.94	1.86	0.84	1.31	1.56	2.00	2.00
400 Vac (560 Vdc) Rated Torque (speed) ①②⑦⑧⑨		T <sub>rtd</sub>	Nm	3.74	3.01	3.03	-	-	4.61	3.19	3.18	3.24	-
			lb-in	33.11	26.6	26.8	-	-	40.8	28.2	28.1	28.7	-
Rated Speed		N <sub>rtd</sub>	rpm	2,500	4,500	4,500	-	-	2,000	4,500	4,500	4,500	-
Rated Power (speed) ①②⑦⑧⑨		P <sub>rtd</sub>	kW	0.98	1.42	1.43	-	-	0.97	1.50	1.50	1.53	-
			Hp	1.31	1.90	1.92	-	-	1.3	2.01	2.01	2.05	-

See following page for notes.

### NOTE

- Motor performance across the entire speed range varies depending on the selection of feedback device and holding brake.
- The on-line [Performance Curve Generator](#) provides the most accurate information for specific models.
  - A Kollmorgen account and login is required to use this design tool.

## 5.6 AKME43 and AKME44 - Servo Motor Parameters

Parameters	Tol	Sym	Units	AKME43					AKME44				
				E	G	H	K	L	E	G	H	J	K
Torque Constant ①	±10%	K <sub>t</sub>	Nm/A <sub>rms</sub>	1.72	0.99	0.89	0.52	0.43	2.04	1.2	1.06	0.69	0.59
			lb-in/A <sub>rms</sub>	15.2	8.8	7.9	4.6	3.8	18.1	10.6	9.4	6.1	5.2
Back EMF Constant ②	±10%	K <sub>e</sub>	V <sub>rms</sub> /krpm	111	63.9	57.4	33.2	27.5	132	77	68	44.2	37.8
Motor Constant	Nom	K <sub>m</sub>	N-m/√W	0.479	0.482	0.501	0.494	0.465	0.567	0.567	0.58	0.581	0.567
			lb-in/√W	4.24	4.29	4.44	4.37	4.12	5.01	5.03	5.13	5.14	5.1
Resistance (line-line) ⑥	±10%	R <sub>m</sub>	ohm	8.61	2.81	2.2	0.74	0.57	8.64	2.8	2.23	0.94	0.68
Inductance (line-line)		L	mH	32.6	10.8	8.8	2.9	2	33.9	11.5	9.1	3.8	2.8
Inertia (includes Resolver feedback) ③	±10%	J <sub>m</sub>	kg-cm <sup>2</sup>	2.1					2.7				
			lb-in-s <sup>2</sup>	1.80E-03					2.40E-03				
Optional Brake Inertia (additional) ⑧	±10%	J <sub>m</sub>	kg-cm <sup>2</sup>	0.058					0.058				
			lb-in-s <sup>2</sup>	5.10E-05					5.10E-05				
Weight (w/o brake) ⑩		W	kg	4.35					5.3				
			lb	9.6					11.7				
Static Friction ①		T <sub>f</sub>	Nm	0.109					0.121				
			lb-in	0.97					1.07				
Viscous Damping ①		K <sub>dv</sub>	Nm/krpm	0.017					0.021				
			lb-in/krpm	0.15					0.19				
Thermal Time Constant		TCT	minutes	20					24				
Thermal Resistance		R <sub>thw-a</sub>	°C/W	0.7					0.65				
Operating Ambient Temperature Range ⑫⑬			°C	5 to 40					5 to 40				
Pole Pairs				5					5				
Heat Sink Size				10"x10"x1/4" Aluminum Plate					10"x10"x1/4" Aluminum Plate				

Additional windings may exist. Please contact Kollmorgen Customer Support for further information or to request custom winding options for your application requirements.

Notes:

- ① Motor winding temperature rise, ΔT=95°C, at 40°C ambient.
- ② All data referenced to sinusoidal commutation.
- ③ Add parking brake if applicable for total inertia.
- ④ Motor with standard heat sink.
- ⑤ May be limited at some values of V<sub>bus</sub>.
- ⑥ Measured at 25°C.
- ⑦ Brake motor option reduces continuous torque ratings by 0.12 Nm.
- ⑧ Non-Resolver feedback options reduces continuous ratings by:  
AKME41 = 0.1 Nm AKME42 = 0.1 Nm AKME43 = 0.2 Nm AKME44 = 0.3 Nm
- ⑨ Motors with non-resolver feedback and brake option, reduce continuous torque by:  
AKME41 = 0.22 Nm AKME42 = 0.36 Nm AKME43 = 0.55 Nm AKME44 = 0.76 Nm
- ⑩ Brake option increases weight by 0.69 kg (1.52 lb).
- ⑪ Motors can be operated up to 400 Vac. For performances curves at voltages, listed or unlisted, please use our online Performance Curve Generator Tool.
- ⑫ Brake option will operate in this range in a non-condensing environment. See the Brake Option section for more information.
- ⑬ The applied holding brake voltage must be limited to 17 V to maintain ATEX/IECEx T4 temperature class compliance.
- ⑭ For AKME4 the maximum speed is limited up to 4500 rpm.

## 6 AKME5 - Technical Data

- All data is valid for 40 °C environmental temperature and 95K overtemperature of the winding.
- Determination of nominal data with constant temperature of adapter flange of 65 °C.
- The data can have a tolerance of +/- 10%.

---

6.1 AKME5 - Dimensional Drawings .....	97
6.2 AKME5 - Dimension Data .....	98
6.3 AKME51 and AKME52 - Performance Data .....	99
6.4 AKME51 and AKME52 - Servo Motor Parameters .....	100
6.5 AKME53 and AKME54 - Performance Data .....	101
6.6 AKME53 and AKME54 - Servo Motor Parameters .....	102

## 6.1 AKME5 - Dimensional Drawings

### ! IMPORTANT

- All drawings are in principle (not scaled).
- 3D Models are available at [Kollmorgen Design Tools - 3D Models](#).

#### 4- Connector Option

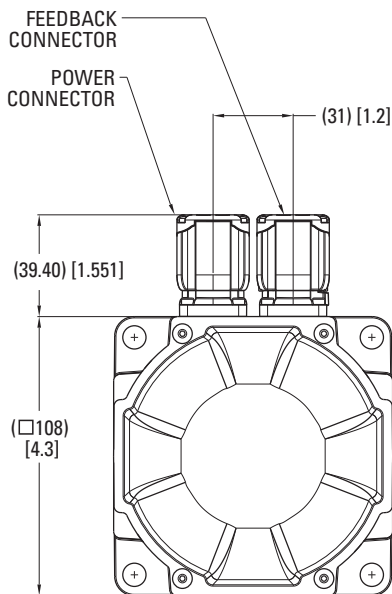
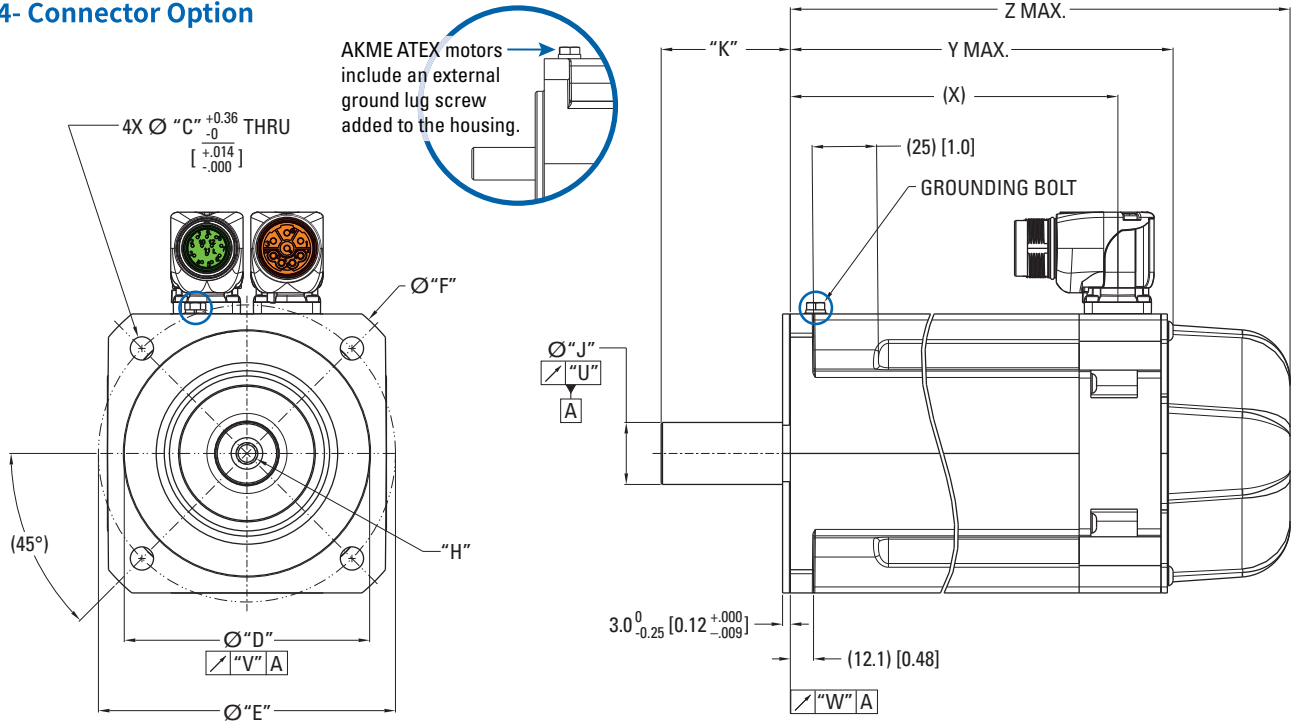

#### 9- Connector Option

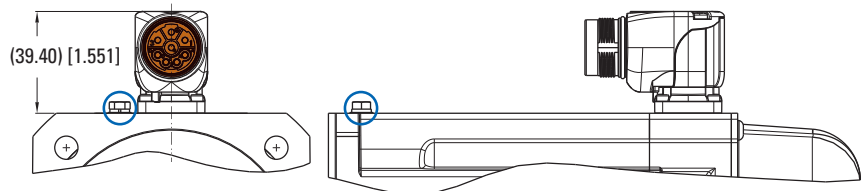

#### Shaft-keyway dimensions

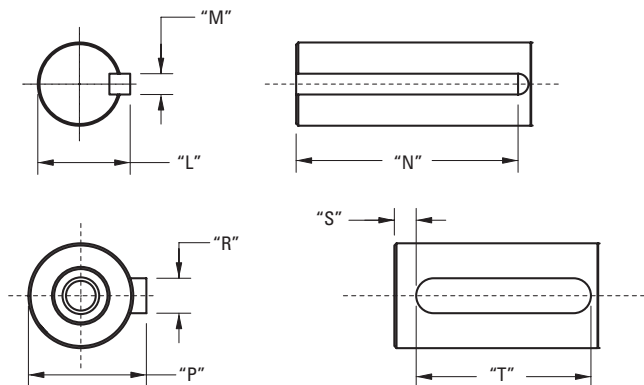

## 6.2 AKME5 - Dimension Data

### AKME5x Mounting Flange-Shaft Dimensional Data

Mounting Flange-Shaft	Hole Diameter "C"	Pilot Diameter "D"	Bolt Circle Dia. "E"	"F"	"H"	Shaft Diameter "J"	Shaft Length "K"	Shaft Dia. w/ Key "L"
AC	9 [0.354]	110 [4.3307]	130 [5.118]	-	D M8 DIN 332	24 [0.9449]	50.0 [1.97]	-
AN	9 [0.354]	110 [4.3307]	130 [5.118]	-	D M8 DIN 332	24 [0.9449]	50.0 [1.97]	-
BK	8.33 [0.328]	55.563 [2.1874]	125.73 [4.950]	-	-	19.05 [0.7500]	57.15 [2.250]	21.15 [0.83]
CC	9 [0.354]	95 [3.7402]	115 [4.528]	140 [5.512]	D M8 DIN 332	24 [0.9449]	50.0 [1.97]	-
CN	9 [0.354]	95 [3.7402]	115 [4.528]	140 [5.512]	D M8 DIN 332	24 [0.9449]	50.0 [1.97]	-
DK	8.33 [0.328]	63.5 [2.500]	127 [5.000]	-	-	19.05 [0.7500]	57.15 [2.250]	21.15 [0.83]
EK	8.33 [0.328]	55.563 [2.1874]	125.73 [4.950]	-	-	15.875 [0.6250]	44.45 [1.750]	17.91 [0.705]
GC	9 [0.354]	110 [4.3307]	130 [5.118]	-	D M6 DIN 332	19 [0.7480]	40 [1.57]	-
GN	9 [0.354]	110 [4.3307]	130 [5.118]	-	D M6 DIN 332	19 [0.7480]	40.0 [1.57]	-
HC	9 [0.354]	95 [3.7402]	115 [4.528]	140 [5.512]	D M6 DIN 332	19 [0.7480]	40 [1.57]	-
HN	9 [0.354]	95 [3.7402]	115 [4.528]	140 [5.512]	D M6 DIN 332	19 [0.7480]	40.0 [1.57]	-

Mounting Flange-Shaft	Key Width "M"	Key Length "N"	Shaft Dia. w/ Key "P"	Key Width "R"	"S"	Key Length "T"	"U"	"V"	"W"
AC	-	-	27 [1.063]	8 [0.3150]	5.00 [0.197]	40 [1.575]	0.040 [0.0015]	0.100 [0.0039]	0.100 [0.0039]
AN	-	-	-	-	-	-	0.040 [0.0015]	0.100 [0.0039]	0.100 [0.0039]
BK	4.763 [0.1875]	38.1 [1.500]	-	-	-	-	0.051 [0.0020]	0.10 [0.004]	0.10 [0.004]
CC	-	-	27 [1.063]	8 [0.3150]	5.00 [0.197]	40 [1.575]	0.040 [0.0015]	0.080 [0.0031]	0.080 [0.0031]
CN	-	-	-	-	-	-	0.040 [0.0015]	0.080 [0.0031]	0.080 [0.0031]
DK	4.763 [0.1875]	34.93 [1.375]	-	-	-	-	0.051 [0.0020]	0.05 [0.002]	0.10 [0.004]
EK	4.763 [0.1875]	38.1 [1.500]	-	-	-	-	0.051 [0.0020]	0.10 [0.004]	0.10 [0.004]
GC	-	-	21.5 [0.846]	6 [0.236]	4.00 [0.157]	32 [1.260]	0.040 [0.0015]	0.080 [0.0031]	0.080 [0.0031]
GN	-	-	-	-	-	-	-	-	-
HC	-	-	21.5 [0.846]	6 [0.236]	4.00 [0.157]	32 [1.260]	0.040 [0.0015]	0.080 [0.0031]	0.080 [0.0031]
HN	-	-	-	-	-	-	-	-	-

### AKME5x Motor Length Dimensional Data

	No Brake (N)		
	X	Y MAX	Z MAX
Feedback Option	R, 2-, Ax, Dx, Gx, CB	R, 2-, CB	Ax, Dx, Gx
AKME51	105.3 [4.15]	127.5 [5.02]	146 [5.75]
AKME52	136.3 [5.37]	158.5 [6.24]	177 [6.97]
AKME53	167.3 [6.59]	189.5 [7.46]	208 [8.19]
AKME54	198.3 [7.81]	220.5 [8.68]	239 [9.41]

	Brake (2)		
	X	Z MAX	
Feedback Option	R, 2-, Ax, Dx, Gx, CB	R, 2-, CB	Ax, Dx, Gx
AKME51	105.3 [4.15]	172.5 [6.79]	189 [7.44]
AKME52	136.3 [5.37]	203.5 [8.01]	220 [8.66]
AKME53	167.3 [6.59]	234.5 [9.23]	251 [9.88]
AKME54	198.3 [7.81]	265.5 [10.45]	282 [11.1]

Note 1: Dimensions are in mm [inches].

Note 2: Product designed in metric. English conversions provided for reference only.

### 6.3 AKME51 and AKME52 - Performance Data



To maintain compliance, the rated torque, speed, and power used cannot exceed the limits set in the "IECEX - Conformity Certificate Annex" (→ p. 153).

Parameters	Tol	Sym	Units	AKME51					AKME52				
				E	G	H	K	L	E	G	H	K	L
Max Rated Voltage ⑩	Max	-	Vac	400	400	400	240	120	400	400	400	240	240
			Vdc	560	560	560	320	160	560	560	560	320	320
Continuous Torque for ΔT winding = 95°C ①②⑦⑧⑨	Nom	T <sub>CS</sub>	Nm	4.47	4.54	4.57	4.67	4.67	8.0	8.1	8.19	8.3	8.4
			lb-in	39.6	40.2	40.4	41.3	41.3	71	72	72.5	74	74
Continuous Current for ΔT winding = 95°C ①②⑦⑧⑨	Nom	I <sub>CS</sub>	A <sub>RMS</sub>	2.68	4.73	5.9	9.2	11.6	2.92	4.61	5.78	9.1	11.3
Continuous Torque for ΔT winding = 60°C ②	Nom	T <sub>CS</sub>	Nm	3.58	3.63	3.66	3.74	3.74	6.4	6.5	6.8	6.6	6.7
			lb-in	31.7	32.1	32.4	33.1	33.1	57	58	60	58	59
Max Mechanical Speed ⑤⑥	Nom	N <sub>max</sub>	rpm	6000	6000	6000	6000	6000	6000	6000	6000	6000	6000
Peak Torque ①②	Nom	T <sub>p</sub>	Nm	11.5	11.6	11.6	11.8	11.9	21.2	21.3	21.6	21.8	21.8
			lb-in	102	103	103	104	105	188	189	191	193	193
Peak Current	Nom	I <sub>p</sub>	A <sub>RMS</sub>	8.2	14.5	18.0	28.2	35.7	9.0	14.1	17.7	27.9	34.8
75 Vdc Rated Torque (speed) ①②⑦⑧⑨		T <sub>rtd</sub>	Nm	-	-	-	-	4.26	-	-	-	-	-
			lb-in	-	-	-	-	37.7	-	-	-	-	-
Rated Speed		N <sub>rtd</sub>	rpm	-	-	-	-	1500	-	-	-	-	-
Rated Power (speed) ①②⑦⑧⑨		P <sub>rtd</sub>	kW	-	-	-	-	0.67	-	-	-	-	-
			Hp	-	-	-	-	0.90	-	-	-	-	-
120 Vac (160 Vdc) Rated Torque (speed) ①②⑦⑧⑨		T <sub>rtd</sub>	Nm	-	-	-	3.89	3.69	-	-	7.7	-	7.6
			lb-in	-	-	-	34.4	32.7	-	-	68	-	67
Rated Speed		N <sub>rtd</sub>	rpm	-	-	-	2500	3000	-	-	1000	-	1500
Rated Power (speed) ①②⑦⑧⑨		P <sub>rtd</sub>	kW	-	-	-	1.02	1.16	-	-	0.8	-	1.19
			Hp	-	-	-	1.37	1.56	-	-	1.07	-	1.60
240 Vac (320 Vdc) Rated Torque (speed) ①②⑦⑧⑨		T <sub>rtd</sub>	Nm	4.16	3.78	3.61	3.42	-	-	7.4	7.2	6.44	6.0
			lb-in	36.8	33.5	31.9	30.3	-	-	65	64	57	53
Rated Speed		N <sub>rtd</sub>	rpm	1200	2500	3000	3500	-	-	1500	1800	3000	3500
Rated Power (speed) ①②⑦⑧⑨		P <sub>rtd</sub>	kW	0.52	0.99	1.13	1.25	-	-	1.16	1.36	2.02	2.20
			Hp	0.70	1.33	1.52	1.68	-	-	1.56	1.82	2.71	2.95
400 Vac (560 Vdc) Rated Torque (speed) ①②⑦⑧⑨		T <sub>rtd</sub>	Nm	3.73	3.33	-	-	-	7.3	6.7	5.9	-	-
			lb-in	33.0	29.5	-	-	-	64	59	52	-	-
Rated Speed		N <sub>rtd</sub>	rpm	2500	3500	-	-	-	1500	2500	3500	-	-
Rated Power (speed) ①②⑦⑧⑨		P <sub>rtd</sub>	kW	0.98	1.22	-	-	-	1.15	1.75	2.16	-	-
			Hp	1.31	1.64	-	-	-	1.54	2.35	2.90	-	-

See following page for notes.

#### NOTE

- Motor performance across the entire speed range varies depending on the selection of feedback device and holding brake.
- The on-line [Performance Curve Generator](#) provides the most accurate information for specific models.
  - A Kollmorgen account and login is required to use this design tool.

## 6.4 AKME51 and AKME52 - Servo Motor Parameters

Parameters	Tol	Sym	Units	AKME51					AKME52					
				E	G	H	K	L	E	G	H	K	L	M
Torque Constant ①	±10%	K <sub>t</sub>	Nm/A <sub>rms</sub>	1.71	0.99	0.79	0.52	0.41	2.78	1.79	1.44	0.93	0.75	0.66
			lb-in/A <sub>rms</sub>	15.2	8.8	7	4.6	3.63	24.6	15.8	12.7	8.2	6.6	5.8
Back EMF Constant ②	±10%	K <sub>e</sub>	V <sub>rms</sub> /krpm	110	63.6	51.3	33.5	26.6	179	115	92.7	60.1	48.3	42.4
Motor Constant	Nom	K <sub>m</sub>	N-m/√W	0.469	0.477	0.465	0.49	0.447	0.761	0.76	0.767	0.775	0.784	0.77
			lb-in/√W	4.15	4.24	4.12	4.35	3.96	6.73	6.71	6.79	6.83	6.94	6.81
Resistance (line-line) ⑥	±10%	R <sub>m</sub>	ohm	9	2.87	1.85	0.75	0.49	9	3.7	2.35	0.96	0.61	0.49
Inductance (line-line)		L	mH	36.6	12.1	7.9	3.38	2.13	44.7	18.5	11.9	5	3.24	2.5
Inertia (includes Resolver feedback) ③	±10%	J <sub>m</sub>	kg-cm <sup>2</sup>	3.4					6.2					
			lb-in-s <sup>2</sup>	3.00E-03					5.50E-03					
Optional Brake Inertia (additional) ④	±10%	J <sub>m</sub>	kg-cm <sup>2</sup>	0.166					0.166					
			lb-in-s <sup>2</sup>	1.47E-04					1.47E-04					
Weight (w/o brake) ⑤		W	kg	4.2					5.8					
			lb	9.3					12.8					
Static Friction ①		T <sub>f</sub>	Nm	0.152					0.17					
			lb-in	1.39					1.55					
Viscous Damping ①		K <sub>dv</sub>	Nm/krpm	0.033					0.042					
			lb-in/krpm	0.29					0.37					
Thermal Time Constant		TCT	minutes	20					24					
Thermal Resistance		R <sub>thw-a</sub>	°C/W	0.68					0.56					
Operating Ambient Temperature Range ⑧⑨			°C	5 to 40					5 to 40					
Pole Pairs				5					5					
Heat Sink Size				12"x12"x1/2" Aluminum Plate					12"x12"x1/2" Aluminum Plate					

Additional windings may exist. Please contact Kollmorgen Customer Support for further information or to request custom winding options for your application requirements.

Notes:

① Motor winding temperature rise, ΔT=95°C, at 40°C ambient.

② All data referenced to sinusoidal commutation.

③ Add parking brake if applicable for total inertia.

④ Motor with standard heat sink.

⑤ May be limited at some values of V<sub>bus</sub>.

⑥ Measured at 25°C.

⑦ Brake option reduces continuous torque ratings by:

AKME51 = 0.46 Nm AKME52 = 0.80 Nm AKME53 = 1.08 Nm AKME54 = 1.33 Nm

⑧ Non-Resolver feedback options reduce continuous torque ratings by:

AKME51 = 0.15 Nm AKME52 = 0.34 Nm AKME53 = 0.58 Nm AKME54 = 0.86 Nm

⑨ Motors with non-resolver feedback and brake option, reduce continuous torque by:

AKME51 = 0.46 Nm AKME52 = 0.80 Nm AKME53 = 1.08 Nm AKME54 = 1.33 Nm

⑩ Brake option increases weight by 1.23 kg (2.71 lb).

⑪ If compliance to UL 508 is required, then any winding above 16Arms/Phase continuous current rating, requires M40 "H" connector. Future UL60079 certification will provide guidance. Please contact Kollmorgen Customer Service for co-engineered solution evaluation.

⑫ Motors can be operated up to 400 Vac. For performances curves at voltages, listed or unlisted, please use our online Performance Curve Generator Tool.

⑬ Brake option will operate in this range in a non-condensing environment. See the Brake Option section for more information.

⑭ The applied holding brake voltage must be limited to 17 V to maintain ATEX/IECEx T4 temperature class compliance.

⑮ For AKME5 the maximum speed is limited up to 3500 rpm.

## 6.5 AKME53 and AKME54 - Performance Data



To maintain compliance, the rated torque, speed, and power used cannot exceed the limits set in the "IECEX - Conformity Certificate Annex" (→ p. 153).

Parameters	Tol	Sym	Units	AKME53							AKME54					
				G	H	K	L	M	P <sup>Ⓜ</sup>	Q <sup>Ⓜ</sup>	G	H	K	L	N <sup>Ⓜ</sup>	P <sup>Ⓜ</sup>
Max Rated Voltage <sup>Ⓜ</sup>	Max	-	Vac	400	400	400	240	240	240	120	400	400	400	240	240	240
			Vdc	560	560	560	320	320	320	160	560	560	560	320	320	320
Continuous Torque for ΔT winding = 95°C <sup>Ⓜ②⑦⑧⑨</sup>	Nom	T <sub>CS</sub>	Nm	11.0	11.2	11.2	11.3	11.0	11.0	11.2	13.8	13.8	14.1	13.7	13.7	14.0
			lb-in	97	99	99	100	97	98	99	122	122	125	121	121	124
Continuous Current for ΔT winding = 95°C <sup>Ⓜ②⑦⑧⑨</sup>	Nom	I <sub>CS</sub>	A <sub>rms</sub>	4.66	6.5	9.2	11.5	13.1	18.7	20.6	4.84	5.4	9.5	12.2	17.4	19.2
Continuous Torque for ΔT winding = 60°C <sup>②</sup>	Nom	T <sub>CS</sub>	Nm	8.8	9.0	9.0	9.0	8.8	8.8	9.0	11.0	11.0	11.3	11.0	11.0	11.5
			lb-in	78	80	80	80	78	78	80	97	97	100	97	97	99
Max Mechanical Speed <sup>Ⓜ⑥</sup>	Nom	N <sub>max</sub>	rpm	6000	6000	6000	6000	6000	6000	6000	6000	6000	6000	6000	6000	
Peak Torque <sup>Ⓜ②</sup>	Nom	T <sub>p</sub>	Nm	29.7	29.9	30.1	30.1	29.6	29.6	30.1	37.3	37.4	38.2	37.4	37.4	37.9
			lb-in	263	265	266	266	262	262	266	330	331	338	331	331	335
Peak Current	Nom	I <sub>p</sub>	A <sub>rms</sub>	14.4	19.8	28.2	35.4	40.2	57	63	14.7	16.5	29.1	37.5	53	58.8
75 Vdc Rated Torque (speed) <sup>Ⓜ②⑦⑧⑨</sup>		T <sub>rtd</sub>	Nm	-	-	-	-	-	-	10.5	-	-	-	-	-	13.3
			lb-in	-	-	-	-	-	-	93	-	-	-	-	-	117
Rated Speed		N <sub>rtd</sub>	rpm	-	-	-	-	-	-	1000	-	-	-	-	-	800
Rated Power (speed) <sup>Ⓜ②⑦⑧⑨</sup>		P <sub>rtd</sub>	kW	-	-	-	-	-	-	1.1	-	-	-	-	-	1.11
			Hp	-	-	-	-	-	-	-	1.48	-	-	-	-	-
120 Vac (160 Vdc) Rated Torque (speed) <sup>Ⓜ②⑦⑧⑨</sup>		T <sub>rtd</sub>	Nm	-	-	-	-	-	-	9.2	-	-	-	-	-	11.9
			lb-in	-	-	-	-	-	-	-	81	-	-	-	-	-
Rated Speed		N <sub>rtd</sub>	rpm	-	-	-	-	-	-	2500	-	-	-	-	-	2000
Rated Power (speed) <sup>Ⓜ②⑦⑧⑨</sup>		P <sub>rtd</sub>	kW	-	-	-	-	-	-	2.41	-	-	-	-	-	2.49
			Hp	-	-	-	-	-	-	-	3.23	-	-	-	-	-
240 Vac (320 Vdc) Rated Torque (speed) <sup>Ⓜ②⑦⑧⑨</sup>		T <sub>rtd</sub>	Nm	10.3	10.1	9.6	8.4	8.3	7.7	-	-	12.9	12.2	11.0	9.3	9.43
			lb-in	91	89	85	75	73	68	-	-	114	108	97	82	83
Rated Speed		N <sub>rtd</sub>	rpm	1000	1500	2000	3000	3000	3500	-	-	1000	1800	2500	3500	3500
Rated Power (speed) <sup>Ⓜ②⑦⑧⑨</sup>		P <sub>rtd</sub>	kW	1.08	1.59	2.01	2.64	2.59	2.80	-	-	1.35	2.30	2.88	3.41	3.46
			Hp	1.45	2.13	2.70	3.54	3.47	3.76	-	-	1.81	3.08	3.86	4.57	4.64
400 Vac (560 Vdc) Rated Torque (speed) <sup>Ⓜ②⑦⑧⑨</sup>		T <sub>rtd</sub>	Nm	9.4	8.4	7.8	-	-	-	-	12.4	12.1	9.53	-	-	-
			lb-in	83	74	69	-	-	-	-	-	110	107	84	-	-
Rated Speed		N <sub>rtd</sub>	rpm	2000	3000	3500	-	-	-	-	1500	1800	3500	-	-	-
Rated Power (speed) <sup>Ⓜ②⑦⑧⑨</sup>		P <sub>rtd</sub>	kW	1.97	2.64	2.86	-	-	-	-	1.95	2.28	3.49	-	-	-
			Hp	2.64	3.54	3.83	-	-	-	-	-	2.61	3.06	4.68	-	-

See following page for notes.

### NOTE

- Motor performance across the entire speed range varies depending on the selection of feedback device and holding brake.
- The on-line [Performance Curve Generator](#) provides the most accurate information for specific models.
  - A Kollmorgen account and login is required to use this design tool.

## 6.6 AKME53 and AKME54 - Servo Motor Parameters

Parameters	Tol	Sym	Units	AKME53							AKME54					
				G	H	K	L	M	P	Q	G	H	K	L	N	P
Torque Constant ①	±10%	$K_t$	Nm/A <sub>rms</sub>	2.39	1.74	1.24	0.99	0.85	0.6	0.55	2.87	2.58	1.51	1.13	0.79	0.73
			lb-in/A <sub>rms</sub>	21.2	15.4	11	8.8	7.5	5.3	4.9	25.4	22.8	13.4	10	7	6.5
Back EMF Constant ②	±10%	$K_e$	V <sub>rms</sub> /krpm	154	112	79.8	63.6	54.7	38.4	35.5	185	166	96.6	72.9	51.3	47.3
Motor Constant	Nom	$K_m$	N-m/√W	0.979	0.986	0.983	0.973	0.972	0.926	0.98	1.164	1.19	1.18	1.14	1.14	1.163
			lb-in/√W	8.67	8.73	8.72	8.61	8.57	8.19	8.76	10.31	10.5	10.4	10.1	10.1	10.21
Resistance (line-line) ⑥	±10%	$R_m$	ohm	3.97	2.1	1.06	0.69	0.51	0.28	0.21	4.08	3.2	1.08	0.65	0.33	0.27
Inductance (line-line)		L	mH	21.3	11.4	5.7	3.64	2.7	1.3	1.14	22.9	18.3	6.2	3.5	1.75	1.49
Inertia (includes Resolver feedback) ③	±10%	$J_m$	kg-cm <sup>2</sup>	9.1							12					
			lb-in-s <sup>2</sup>	8.10E-03							0.011					
Optional Brake Inertia (additional) ④	±10%	$J_m$	kg-cm <sup>2</sup>	0.166							0.166					
			lb-in-s <sup>2</sup>	1.47E-04							1.47E-04					
Weight (w/o brake) ⑤		W	kg	7.4							9					
			lb	16.3							19.8					
Static Friction ①		$T_f$	Nm	0.188							0.207					
			lb-in	1.71							1.88					
Viscous Damping ①		$K_{dv}$	Nm/krpm	0.052							0.061					
			lb-in/krpm	0.46							0.54					
Thermal Time Constant		TCT	minutes	28							31					
Thermal Resistance		$R_{thw-a}$	°C/W	0.5							0.45					
Operating Ambient Temperature Range ⑧⑨			°C	5 to 40							5 to 40					
Pole Pairs				5							5					
Heat Sink Size				12"x12"x1/2" Aluminum Plate							12"x12"x1/2" Aluminum Plate					

Additional windings may exist. Please contact Kollmorgen Customer Support for further information or to request custom winding options for your application requirements.

Notes:

① Motor winding temperature rise,  $\Delta T=95^\circ\text{C}$ , at  $40^\circ\text{C}$  ambient.

② All data referenced to sinusoidal commutation.

③ Add parking brake if applicable for total inertia.

④ Motor with standard heat sink.

⑤ May be limited at some values of  $V_{bus}$ .

⑥ Measured at  $25^\circ\text{C}$ .

⑦ Brake option reduces continuous torque ratings by:

AKME51 = 0.46 Nm AKME52 = 0.80 Nm AKME53 = 1.08 Nm AKME54 = 1.33 Nm

⑧ Non-Resolver feedback options reduce continuous torque ratings by:

AKME51 = 0.15 Nm AKME52 = 0.34 Nm AKME53 = 0.58 Nm AKME54 = 0.86 Nm

⑨ Motors with non-resolver feedback and brake option, reduce continuous torque by:

AKME51 = 0.46 Nm AKME52 = 0.80 Nm AKME53 = 1.08 Nm AKME54 = 1.33 Nm

⑩ Brake option increases weight by 1.23 kg (2.71 lb).

⑪ If compliance to UL 508 is required, then any winding above 16Arms/Phase continuous current rating, requires M40 "H" connector. Future UL60079 certification will provide guidance. Please contact Kollmorgen Customer Service for co-engineered solution evaluation.

⑫ Motors can be operated up to 400 Vac. For performances curves at voltages, listed or unlisted, please use our online Performance Curve Generator Tool.

⑬ Brake option will operate in this range in a non-condensing environment. See the Brake Option section for more information.

⑭ The applied holding brake voltage must be limited to 17 V to maintain ATEX/IECEx T4 temperature class compliance.

⑮ For AKME5 the maximum speed is limited up to 3500 rpm.

## 7 AKME6 - Technical Data

- All data is valid for 40 °C environmental temperature and 95K overtemperature of the winding.
- Determination of nominal data with constant temperature of adapter flange of 65 °C.
- The data can have a tolerance of +/- 10%.

---

<b>7.1 AKME6 - Dimensional Drawings</b> .....	<b>104</b>
<b>7.2 AKME6 - Dimension Data</b> .....	<b>105</b>
<b>7.3 AKME62 and AKME63 - Performance Data</b> .....	<b>106</b>
<b>7.4 AKME62 and AKME63 - Servo Motor Parameters</b> .....	<b>107</b>
<b>7.5 AKME64 and AKME65 - Performance Data</b> .....	<b>108</b>
<b>7.6 AKME64 and AKME65 - Servo Motor Parameters</b> .....	<b>109</b>

## 7.1 AKME6 - Dimensional Drawings

### ! IMPORTANT

- All drawings are in principle (not scaled).
- 3D Models are available at [Kollmorgen Design Tools - 3D Models](#).

#### ☒- Connector Option

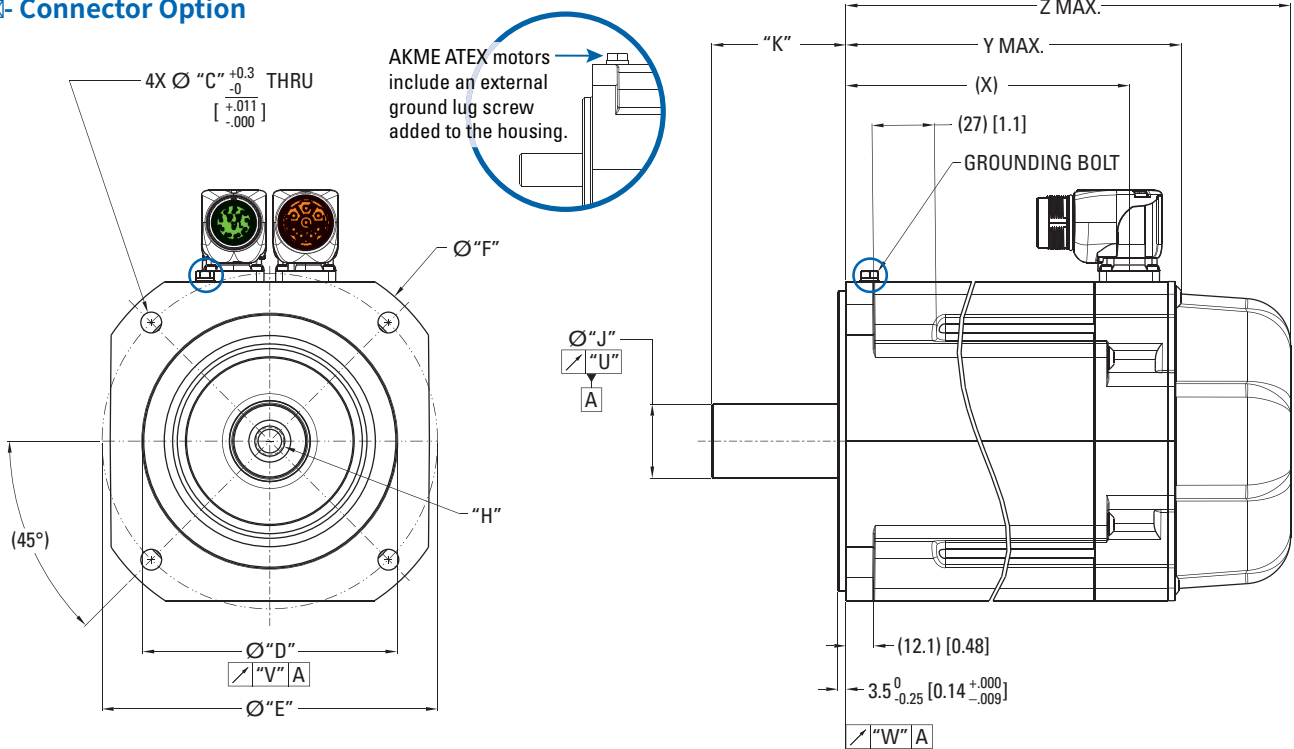

#### ☒- Connector Option

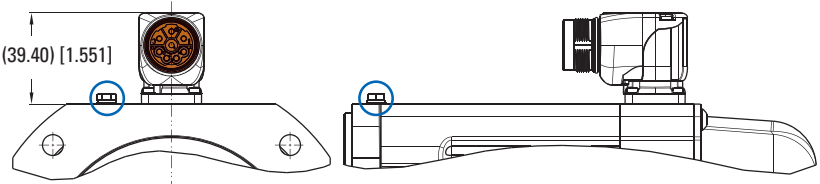
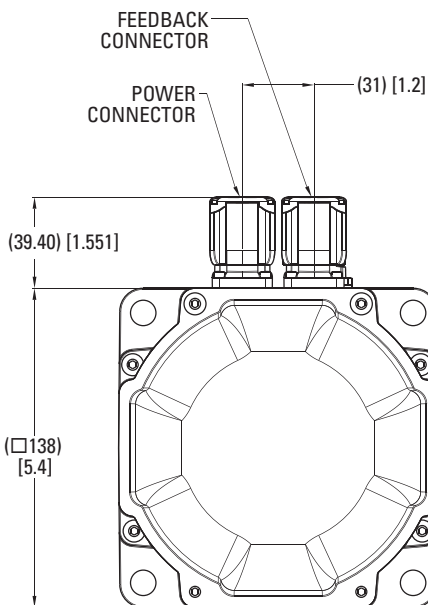

#### Shaft-keyway dimensions

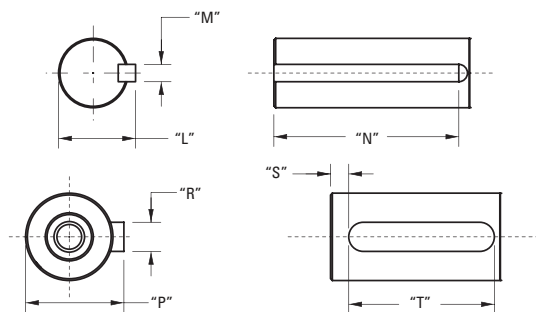

## 7.2 AKME6 - Dimension Data

### AKME6x Mounting Flange-Shaft Dimensional Data

Mounting Flange-Shaft	Hole Diameter "C"	Pilot Diameter "D"	Bolt Circle Dia. "E"	"F"	"H"	Shaft Diameter "J"	Shaft Length "K"	Shaft Dia. w/ Key "L"
AC	11.00 [0.433]	130 [5.1181]	165.00 [6.496]	-	D M12 DIN 332	32 [1.2598]	58 [2.28]	-
AN	11.00 [0.433]	130 [5.1181]	165.00 [6.496]	-	D M12 DIN 332	32 [1.2598]	58 [2.28]	-
GC	11.00 [0.433]	130 [5.1181]	165.00 [6.496]	-	D M8 DIN 332	24 [0.9449]	50 [1.97]	-
GN	11.00 [0.433]	130 [5.1181]	165.00 [6.496]	-	D M8 DIN 332	24 [0.9449]	50 [1.97]	-
KK	9.00 [0.354]	110 [4.3307]	145.00 [5.709]	165 [6.496]	-	28 [1.1024]	60 [2.36]	31 [1.220]
LK	3/18 - 16 UNC-2B	114.3 [4.5000]	149.225 [5.875]	165 [6.496]	-	28.580 [1.1250]	69.85 [2.75]	31.39 [1.236]

Mounting Flange-Shaft	Key Width "M"	Key Length "N"	Shaft Dia. w/ Key "P"	Key Width "R"	"S"	Key Length "T"	"U"	"V"	"W"
AC	-	-	35 [1.378]	10 [0.3937]	5.00 [0.197]	45 [1.772]	0.050 [0.0019]	0.100 [0.0039]	0.100 [0.0039]
AN	-	-	-	-	-	-	0.050 [0.0019]	0.100 [0.0039]	0.100 [0.0039]
GC	-	-	27 [1.063]	8 [0.3150]	5.00 [0.197]	40 [1.575]	0.050 [0.0019]	0.100 [0.0039]	0.100 [0.0039]
GN	-	-	-	-	-	-	0.050 [0.0019]	0.100 [0.0039]	0.100 [0.0039]
KK	8 [0.3150]	50 [1.969]	-	-	-	-	0.050 [0.0019]	0.100 [0.0039]	0.100 [0.0039]
LK	6.35 [2.75]	38.1 [1.500]	-	-	-	-	0.050 [0.0019]	0.100 [0.0039]	0.100 [0.0039]

### AKME6x Motor Length Dimensional Data

	No Brake (N)		
	X	Y MAX	Z MAX
Feedback Option	R, 2-, Ax, Dx, Gx, CB	R, 2-, CB	Ax, Dx, Gx
AKME62	130.5 [5.14]	153.7 [6.05]	172.2 [6.78]
AKME63	155.5 [6.12]	178.7 [7.04]	197.2 [7.76]
AKME64	180.5 [7.11]	203.7 [8.02]	222.2 [8.75]
AKME65	205.5 [8.09]	228.7 [9]	247.2 [9.73]

	Brake (2)		
	X	Z MAX	
Feedback Option	R, 2-, Ax, Dx, Gx, CB	R, 2-, CB	Ax, Dx, Gx
AKME62	130.5 [5.14]	200.7 [7.9]	219.7 [8.65]
AKME63	155.5 [6.12]	225.7 [8.89]	244.7 [9.63]
AKME64	180.5 [7.11]	250.7 [9.87]	269.7 [10.62]
AKME65	205.5 [8.09]	275.7 [10.85]	294.7 [11.6]

Note 1: Dimensions are in mm [inches].

Note 2: Product designed in metric. English conversions provided for reference only.

### 7.3 AKME62 and AKME63 - Performance Data



To maintain compliance, the rated torque, speed, and power used cannot exceed the limits set in the "IECEX - Conformity Certificate Annex" (→ p. 153).

Parameters	Tol	Sym	Units	AKME62							AKME63						
				G	H	K	L	M	P <sup>①</sup>	Q <sup>①</sup>	G	H	K	L	M	N <sup>①</sup>	Q <sup>①</sup>
Max Rated Voltage <sup>⑩</sup>	Max	-	Vac	400	400	400	240	240	240	120	400	400	400	400	240	240	120
			Vdc	560	560	560	320	320	320	160	560	560	560	560	320	320	160
Continuous Torque for ΔT winding = 95°C <sup>①②⑦⑧⑨</sup>	Nom	T <sub>CS</sub>	Nm	11.4	11.5	11.7	11.7	11.7	11.8	11.5	15.9	16.0	16.2	16.3	16.5	16.4	16.1
			lb-in	101	102	104	103	104	104	102	141	142	143	144	146	145	143
Continuous Current for ΔT winding = 95°C <sup>①②⑦⑧⑨</sup>	Nom	I <sub>CS</sub>	A <sub>RMS</sub>	4.70	5.3	9.3	11.7	13.1	18.4	21.3	4.40	5.5	9.7	10.8	13.5	17.0	21.8
Continuous Torque for ΔT winding = 60°C <sup>②</sup>	Nom	T <sub>CS</sub>	Nm	9.1	9.2	9.4	9.3	9.4	9.4	9.2	12.7	12.8	13.0	13.0	13.2	13.1	12.9
			lb-in	81	81	83	82	83	83	81	112	113	115	115	117	116	114
Max Mechanical Speed <sup>⑤⑥</sup>	Nom	N <sub>max</sub>	rpm	6000	6000	6000	6000	6000	6000	6000	6000	6000	6000	6000	6000	6000	6000
Peak Torque <sup>①②</sup>	Nom	T <sub>p</sub>	Nm	29.5	29.5	30.0	29.9	30.0	30.1	29.6	41.6	41.9	42.3	42.4	42.8	42.7	42.1
			lb-in	261	261	266	265	266	266	262	368	371	374	375	379	378	373
Peak Current	Nom	I <sub>p</sub>	A <sub>RMS</sub>	14.6	16.3	28.8	36.0	40.2	56	65	13.4	16.8	29.7	33.3	41.4	52	67
75 Vdc	-	T <sub>rtd</sub>	Nm	-	-	-	-	-	-	10.7	-	-	-	-	-	-	15.2
			lb-in	-	-	-	-	-	-	95	-	-	-	-	-	-	-
Rated Speed	-	N <sub>rtd</sub>	rpm	-	-	-	-	-	-	1000	-	-	-	-	-	-	800
Rated Power (speed) <sup>①②⑦⑧⑨</sup>	-	P <sub>rtd</sub>	kW	-	-	-	-	-	-	1.12	-	-	-	-	-	-	1.27
			Hp	-	-	-	-	-	-	1.50	-	-	-	-	-	-	-
120 Vac (160 Vdc)	-	T <sub>rtd</sub>	Nm	-	-	-	-	10.4	10.0	9.3	-	-	-	-	15.2	14.4	13.4
			lb-in	-	-	-	-	92	89	82	-	-	-	-	135	127	119
Rated Speed	-	N <sub>rtd</sub>	rpm	-	-	-	-	1500	2000	2500	-	-	-	-	1000	1500	2000
Rated Power (speed) <sup>①②⑦⑧⑨</sup>	-	P <sub>rtd</sub>	kW	-	-	-	-	1.63	2.09	2.43	-	-	-	-	1.59	2.26	2.81
			Hp	-	-	-	-	2.19	2.79	3.25	-	-	-	-	2.13	3.03	3.77
240 Vac (320 Vdc)	-	T <sub>rtd</sub>	Nm	-	10.7	9.8	9.4	9.5	9.53	-	-	-	14.2	13.9	13.7	13.0	-
			lb-in	-	95	87	83	84	84	-	-	-	-	126	123	121	115
Rated Speed	-	N <sub>rtd</sub>	rpm	-	1000	2000	2500	2500	2500	-	-	-	1500	1800	2000	2500	-
Rated Power (speed) <sup>①②⑦⑧⑨</sup>	-	P <sub>rtd</sub>	kW	-	1.12	2.05	2.46	2.49	2.49	-	-	-	2.23	2.61	2.87	3.40	-
			Hp	-	1.50	2.75	3.30	3.34	3.35	-	-	-	-	2.99	3.50	3.85	4.56
400 Vac (560 Vdc)	-	T <sub>rtd</sub>	Nm	9.8	9.7	9.4	-	-	-	-	14.4	14.0	12.8	12.9	-	-	-
			lb-in	87	86	83	-	-	-	-	127	124	113	114	-	-	-
Rated Speed	-	N <sub>rtd</sub>	rpm	1800	2000	2500	-	-	-	-	1200	1500	2500	2500	-	-	-
Rated Power (speed) <sup>①②⑦⑧⑨</sup>	-	P <sub>rtd</sub>	kW	1.85	2.03	2.46	-	-	-	-	1.81	2.20	3.35	3.38	-	-	-
			Hp	2.48	2.72	3.30	-	-	-	-	2.43	2.95	4.49	4.53	-	-	-

See following page for notes.

**NOTE**

- Motor performance across the entire speed range varies depending on the selection of feedback device and holding brake.
- The on-line [Performance Curve Generator](#) provides the most accurate information for specific models.
  - A Kollmorgen account and login is required to use this design tool.

## 7.4 AKME62 and AKME63 - Servo Motor Parameters

Parameters	Tol	Sym	Units	AKME62								AKME63							
				G	H	K	L	M	P	Q	G	H	K	L	M	N	Q		
Torque Constant ①	±10%	K <sub>t</sub>	Nm/A <sub>rms</sub>	2.47	2.21	1.27	1.03	0.92	0.66	0.55	3.7	2.98	1.71	1.52	1.24	0.98	0.75		
			lb-in/A <sub>rms</sub>	21.9	19.6	11.2	9.1	8.1	5.8	4.87	32.7	26.4	15.1	13.5	11	8.7	6.6		
Back EMF Constant ②	±10%	K <sub>e</sub>	V <sub>rms</sub> /krpm	159	142	82.1	65.5	58.8	42.2	35.5	238	192	110	98.2	79.9	63.3	48.3		
Motor Constant	Nom	K <sub>m</sub>	N-m/√W	0.992	0.989	1.006	0.949	0.984	0.984	1	1.288	1.32	1.308	1.26	1.3	1.281	1.28		
			lb-in/√W	8.8	8.75	8.88	8.4	8.71	8.65	8.85	11.38	11.7	11.55	11.2	11.5	11.37	11.3		
Resistance (line-line) ③	±10%	R <sub>m</sub>	ohm	4.13	3.3	1.08	0.71	0.57	0.3	0.24	5.5	3.43	1.14	0.94	0.61	0.39	0.23		
Inductance (line-line)		L	mH	31.7	25.4	8.5	5.4	4.4	2.2	1.6	43.5	28.1	9.3	7.4	4.9	3.1	1.8		
Inertia (includes Resolver feedback) ④	±10%	J <sub>m</sub>	kg-cm <sup>2</sup>	17								24							
			lb-in-s <sup>2</sup>	0.015								0.021							
Optional Brake Inertia (additional) ⑤	±10%	J <sub>m</sub>	kg-cm <sup>2</sup>	0.668								0.668							
			lb-in-s <sup>2</sup>	5.91E-04								5.91E-04							
Weight (w/o brake) ⑥		W	kg	8.9								11.1							
			lb	19.6								24.4							
Static Friction ⑦		T <sub>f</sub>	Nm	0.3								0.35							
			lb-in	2.65								3.11							
Viscous Damping ⑧		K <sub>dv</sub>	Nm/krpm	0.04								0.06							
			lb-in/krpm	0.35								0.53							
Thermal Time Constant		TCT	minutes	20								25							
Thermal Resistance		R <sub>thw-a</sub>	°C/W	0.46								0.41							
Operating Ambient Temperature Range ⑨⑩			°C	5 to 40								5 to 40							
Pole Pairs				5								5							
Heat Sink Size				18"x18"x1/2" Aluminum Plate								18"x18"x1/2" Aluminum Plate							

Additional windings may exist. Please contact Kollmorgen Customer Support for further information or to request custom winding options for your application requirements.

Notes:

- ① Motor winding temperature rise, ΔT=95°C, at 40°C ambient.
- ② All data referenced to sinusoidal commutation.
- ③ Add parking brake if applicable for total inertia.
- ④ Motor with standard heat sink.
- ⑤ May be limited at some values of V<sub>bus</sub>.
- ⑥ Measured at 25°C.
- ⑦ Brake option reduces continuous torque ratings by:  
AKME62 = 0.5 Nm AKME63 = 0.9 Nm AKME64 = 1.3 Nm AKME65 = 1.7 Nm
- ⑧ Non-Resolver feedback options reduce continuous torque ratings by:  
AKME62 = 0.9 Nm AKME63 = 1.2 Nm AKME64 = 1.5 Nm AKME65 = 1.8 Nm
- ⑨ Motors with non-resolver feedback and brake option, reduce continuous torque by:  
AKME62 = 1.6 Nm AKME63 = 2.4 Nm AKME64 = 3.1 Nm AKME65 = 4.0 Nm
- ⑩ Brake option increases weight by 2.19 kg (4.83 lb).
- ⑪ If compliance to UL 508 is required, then any winding above 16Arms/Phase continuous current rating, requires M40 "H" connector. Future UL60079 certification will provide guidance. Please contact Kollmorgen Customer Service for co-engineered solution evaluation.
- ⑫ Motors can be operated up to 400 Vac. For performances curves at voltages, listed or unlisted, please use our online Performance Curve Generator Tool.
- ⑬ Brake option will operate in this range in a non-condensing environment. See the Brake Option section for more information.
- ⑭ The applied holding brake voltage must be limited to 17 V to maintain ATEX/IECEx T4 temperature class compliance.
- ⑮ For AKME6 the maximum speed is limited up to 2500 rpm.

## 7.5 AKME64 and AKME65 - Performance Data



To maintain compliance, the rated torque, speed, and power used cannot exceed the limits set in the "IECEX - Conformity Certificate Annex" (→ p. 153).

Parameters	Tol	Sym	Units	AKME64				AKME65				
				K	L	P <sup>Ⓜ</sup>	Q <sup>Ⓜ</sup>	K	L	M	N <sup>Ⓜ</sup>	P <sup>Ⓜ</sup>
Max Rated Voltage <sup>Ⓜ</sup>	Max	-	Vac	400	400	240	240	400	400	400	240	240
			Vdc	560	560	320	320	560	560	560	320	320
Continuous Torque for ΔT winding = 95°C <sup>①②⑦⑧⑨</sup>	Nom	T <sub>CS</sub>	Nm	20.1	20.4	19.8	20.0	24.0	24.3	24.4	23.6	23.8
			lb-in	178	181	175	177	212	215	216	209	211
Continuous Current for ΔT winding = 95°C <sup>①②⑦⑧⑨</sup>	Nom	I <sub>CS</sub>	A <sub>RMS</sub>	8.9	12.5	18.2	20.2	9.5	11.9	13.3	17.3	19.3
Continuous Torque for ΔT winding = 60°C <sup>②</sup>	Nom	T <sub>CS</sub>	Nm	16.1	16.3	15.8	16.0	19.2	19.4	19.5	18.9	19.0
			lb-in	142	144	140	142	170	172	173	167	168
Max Mechanical Speed <sup>⑤⑥</sup>	Nom	N <sub>max</sub>	rpm	6000	6000	6000	6000	6000	6000	6000	6000	6000
Peak Torque <sup>①②</sup>	Nom	T <sub>p</sub>	Nm	53	54	53	53	64	65	65	63	64
			lb-in	471	477	469	469	566	575	575	558	566
Peak Current	Nom	I <sub>p</sub>	A <sub>RMS</sub>	27.5	38.4	56	62	29.4	36.6	40.9	53	59
75 Vdc		T <sub>rtd</sub>	Nm	-	-	-	19.3	-	-	-	-	-
			lb-in	-	-	-	170	-	-	-	-	-
75 Vdc		N <sub>rtd</sub>	rpm	-	-	-	500	-	-	-	-	-
75 Vdc		P <sub>rtd</sub>	kW	-	-	-	1.01	-	-	-	-	-
			Hp	-	-	-	1.35	-	-	-	-	-
120 Vac (160 Vdc)		T <sub>rtd</sub>	Nm	-	-	18.2	17.3	-	-	-	21.6	21.8
			lb-in	-	-	161	153	-	-	-	191	193
120 Vac (160 Vdc)		N <sub>rtd</sub>	rpm	-	-	1000	1500	-	-	-	1000	1000
120 Vac (160 Vdc)		P <sub>rtd</sub>	kW	-	-	1.91	2.72	-	-	-	2.26	2.28
			Hp	-	-	2.56	3.65	-	-	-	3.03	3.06
240 Vac (320 Vdc)		T <sub>rtd</sub>	Nm	18.2	17.7	15.2	15.4	22.0	21.6	21.1	19.0	18.1
			lb-in	161	157	135	136	195	191	187	168	160
240 Vac (320 Vdc)		N <sub>rtd</sub>	rpm	1200	1500	2500	2500	1000	1300	1500	2000	2400
240 Vac (320 Vdc)		P <sub>rtd</sub>	kW	2.28	2.78	3.98	4.03	2.30	2.94	3.31	3.98	4.55
			Hp	3.06	3.73	5.34	5.4	3.08	3.94	4.44	5.34	6.1
400 Vac (560 Vdc)		T <sub>rtd</sub>	Nm	16.4	15.7	-	-	19.3	18.3	18.3	-	-
			lb-in	145	139	-	-	171	162	162	-	-
400 Vac (560 Vdc)		N <sub>rtd</sub>	rpm	2000	2500	-	-	2000	2500	2500	-	-
400 Vac (560 Vdc)		P <sub>rtd</sub>	kW	3.43	4.11	-	-	4.04	4.79	4.79	-	-
			Hp	4.60	5.51	-	-	5.42	6.42	6.42	-	-

### NOTE

- Motor performance across the entire speed range varies depending on the selection of feedback device and holding brake.
- The on-line [Performance Curve Generator](#) provides the most accurate information for specific models.
  - A Kollmorgen account and login is required to use this design tool.

## 7.6 AKME64 and AKME65 - Servo Motor Parameters

Parameters	Tol	Sym	Units	AKME64				AKME65				
				K	L	P	Q	K	L	M	N	P
Torque Constant ①	±10%	$K_t$	Nm/A <sub>rms</sub>	2.28	1.66	1.1	0.99	2.55	2.07	1.85	1.38	1.26
			lb-in/A <sub>rms</sub>	20.2	14.7	9.7	8.8	22.6	18.3	16.4	12.2	11.2
Back EMF Constant ②	±10%	$K_e$	V <sub>rms</sub> /krpm	147	107	71	0.64	164	133	119	88.8	80.5
Motor Constant	Nom	$K_m$	N-m/√W	1.57	1.57	1.497	1.44	1.785	1.81	1.77	1.718	1.75
			lb-in/√W	13.9	13.9	13.2	12.8	15.81	16	15.6	15.19	15.4
Resistance (line-line) ③	±10%	$R_m$	ohm	1.41	0.75	0.36	0.3	1.35	0.9	0.73	0.43	0.36
Inductance (line-line)		L	mH	11.8	6.2	2.8	1.9	11.4	7.6	6.1	3.4	2.8
Inertia (includes Resolver feedback) ③	±10%	$J_m$	kg-cm <sup>2</sup>	32				40				
			lb-in-s <sup>2</sup>	0.028				0.035				
Optional Brake Inertia (additional) ④	±10%	$J_m$	kg-cm <sup>2</sup>	0.668				0.668				
			lb-in-s <sup>2</sup>	5.91E-04				5.91E-04				
Weight (w/o brake) ⑤		W	kg	13.3				15.4				
			lb	29.3				33.9				
Static Friction ①		$T_f$	Nm	0.4				0.45				
			lb-in	3.51				4.01				
Viscous Damping ①		$K_{dv}$	Nm/krpm	0.08				0.1				
			lb-in/krpm	0.71				0.9				
Thermal Time Constant		TCT	minutes	30				35				
Thermal Resistance		$R_{thw-a}$	°C/W	0.38				0.35				
Operating Ambient Temperature Range ⑥④			°C	5 to 40				5 to 40				
Pole Pairs				5				5				
Heat Sink Size				18"x18"x1/2" Aluminum Plate				18"x18"x1/2" Aluminum Plate				

Additional windings may exist. Please contact Kollmorgen Customer Support for further information or to request custom winding options for your application requirements.

Notes:

① Motor winding temperature rise,  $\Delta T=95^\circ\text{C}$ , at  $40^\circ\text{C}$  ambient.

② All data referenced to sinusoidal commutation.

③ Add parking brake if applicable for total inertia.

④ Motor with standard heat sink.

⑤ May be limited at some values of  $V_{bus}$ .

⑥ Measured at  $25^\circ\text{C}$ .

⑦ Brake option reduces continuous torque ratings by:

AKME62 = 0.5 Nm AKME63 = 0.9 Nm AKME64 = 1.3 Nm AKME65 = 1.7 Nm

⑧ Non-Resolver feedback options reduce continuous torque ratings by:

AKME62 = 0.9 Nm AKME63 = 1.2 Nm AKME64 = 1.5 Nm AKME65 = 1.8 Nm

⑨ Motors with non-resolver feedback and brake option, reduce continuous torque by:

AKME62 = 1.6 Nm AKME63 = 2.4 Nm AKME64 = 3.1 Nm AKME65 = 4.0 Nm

⑩ Brake option increases weight by 2.19 kg (4.83 lb).

⑪ If compliance to UL 508 is required, then any winding above 16Arms/Phase continuous current rating, requires M40 "H" connector. Future UL60079 certification will provide guidance. Please contact Kollmorgen Customer Service for co-engineered solution evaluation.

⑫ Motors can be operated up to 400 Vac. For performance curves at voltages, listed or unlisted, please use our online Performance Curve Generator Tool.

⑬ Brake option will operate in this range in a non-condensing environment. See the Brake Option section for more information.

⑭ The applied holding brake voltage must be limited to 17 V to maintain ATEX/IECEx T4 temperature class compliance.

⑮ For AKME6 the maximum speed is limited up to 2500 rpm.

## 8 AKME7 - Technical Data

- All data is valid for 40 °C environmental temperature and 95K overtemperature of the winding.
- Determination of nominal data with constant temperature of adapter flange of 65 °C.
- The data can have a tolerance of +/- 10%.

---

<b>8.1 AKME7 - Dimensional Drawings</b> .....	<b>111</b>
<b>8.2 AKME7 - Dimension Data</b> .....	<b>112</b>
<b>8.3 AKME7 - Performance Data</b> .....	<b>113</b>
<b>8.4 AKME7 - Servo Motor Parameters</b> .....	<b>114</b>

## 8.1 AKME7 - Dimensional Drawings

### ! IMPORTANT

- All drawings are in principle (not scaled).
- 3D Models are available at [Kollmorgen Design Tools - 3D Models](#).

### 4- Connector Option

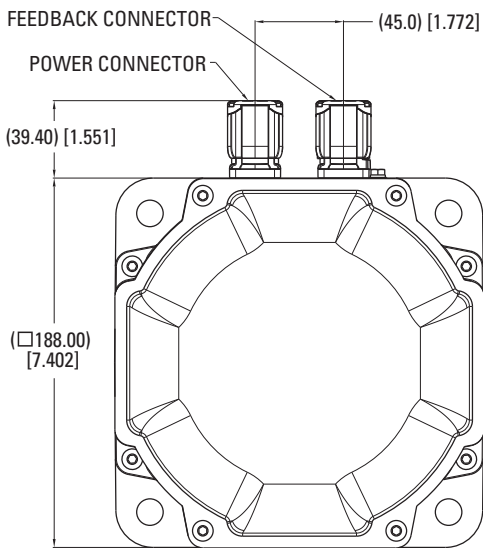
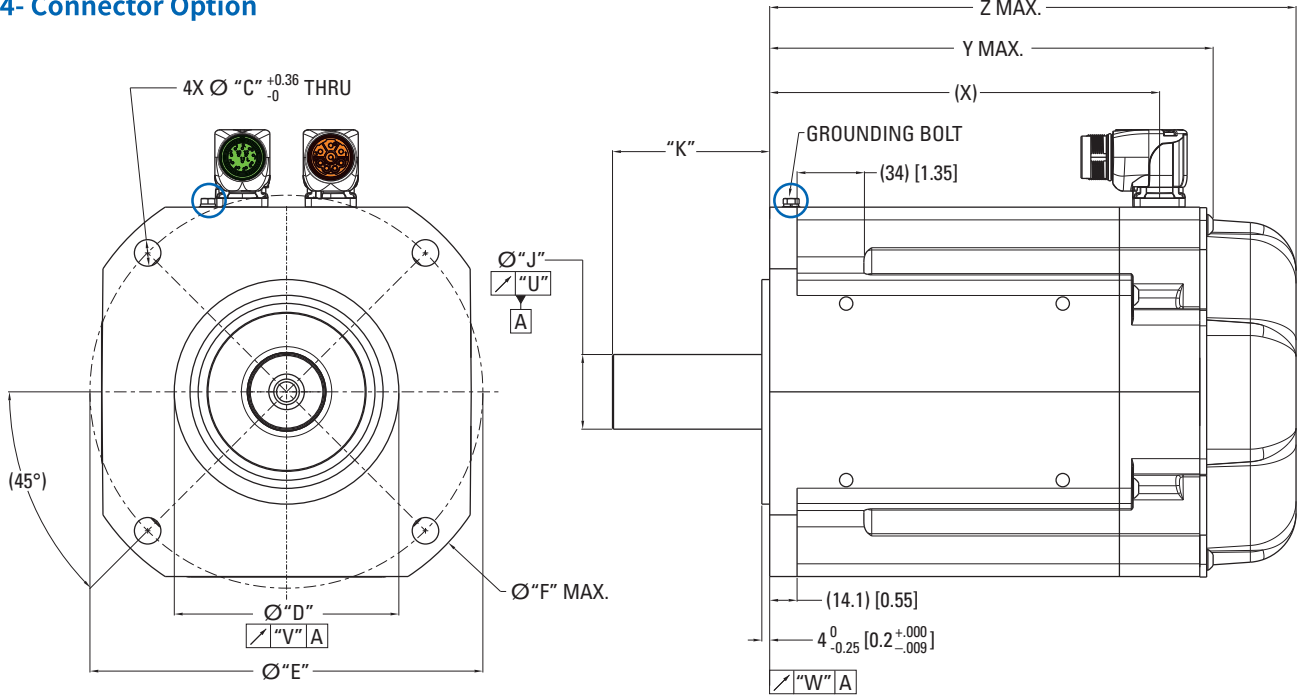

### W- Connector Option

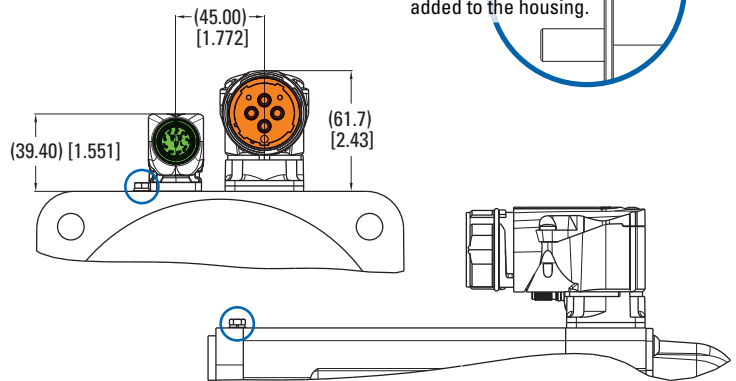

### Shaft-keyway dimensions

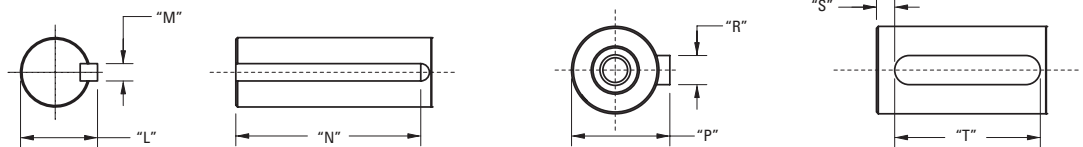

## 8.2 AKME7 - Dimension Data

### AKME7x Mounting Flange-Shaft Dimensional Data

Mounting Flange-Shaft	Hole Diameter "C"	Pilot Diameter "D"	Bolt Circle Dia. "E"	"F"	"H"	Shaft Diameter "J"	Shaft Length "K"	Shaft Dia. w/ Key "L"
AC	13.50 [0.531]	180 [7.0866]	215.00 [8.465]	-	D M12 DIN 332	38 [1.496]	80 [3.15]	-
AN	13.50 [0.531]	180 [7.0866]	215.00 [8.465]	-	D M12 DIN 332	38 [1.496]	80 [3.15]	-
GC	13.50 [0.531]	180 [7.0866]	215.00 [8.465]	-	D M12 DIN 332	32 [1.5298]	58.5 [2.30]	-
GN	13.50 [0.531]	180 [7.0866]	215.00 [8.465]	-	D M12 DIN 332	32 [1.5298]	58.5 [2.30]	-
KK	13.50 [0.531]	114.3 [4.5000]	200 [7.874]	225 [8.858]	-	35 [1.3779]	79 [3.11]	38 [1.496]

Mounting Flange-Shaft	Key Width "M"	Key Length "N"	Shaft Dia. w/ Key "P"	Key Width "R"	"S"	Key Length "T"	"U"	"V"	"W"
AC	-	-	41 [1.614]	10 [0.3937]	5.00 [0.197]	70 [2.756]	0.050 [0.0019]	0.100 [0.0039]	0.100 [0.0039]
AN	-	-	-	-	-	-	0.050 [0.0019]	0.100 [0.0039]	0.100 [0.0039]
GC	-	-	35 [1.378]	108 [0.3937]	4 [0.157]	50 [1.969]	0.050 [0.0019]	0.100 [0.0039]	0.100 [0.0039]
GN	-	-	-	-	-	-	0.050 [0.0019]	0.100 [0.0039]	0.100 [0.0039]
KK	10 [0.3937]	70 [2.756]	-	-	-	-	0.050 [0.0019]	0.100 [0.0039]	0.100 [0.0039]

### AKME7x Motor Length Dimensional Data

	No Brake (N)		
	X	Y MAX	Z MAX
Feedback Option	R, 2-, Ax, Dx, GJ, GK, CB	R, 2-, CB	Ax, Dx, Gx
AKME72	164.5 [6.48]	192.5 [7.58]	201.7 [7.94]
AKME73	198.5 [7.81]	226.5 [8.92]	235.7 [9.28]
AKME74	232.5 [9.15]	260.5 [10.26]	269.7 [10.62]

	Brake (2)		
	X	Z MAX	
Feedback Option	R, 2-, Ax, Dx, Gx, CB	R, 2-, CB	Ax, Dx, Gx
AKME72	164.5 [6.48]	234.5 [9.23]	253.3 [9.97]
AKME73	198.5 [7.81]	268.5 [10.57]	287.3 [11.31]
AKME74	232.5 [9.15]	302.5 [11.91]	321.3 [12.65]

Note 1: Dimensions are in mm [inches].

Note 2: Product designed in metric. English conversions provided for reference only.

### 8.3 AKME7 - Performance Data



To maintain compliance, the rated torque, speed, and power used cannot exceed the limits set in the "IECEx - Conformity Certificate Annex" (→ p. 153).

Parameters	Tol	Symbol	Units	AKME72					AKME73				AKME74		
				K	L	M	P <sup>Ⓜ</sup>	Q <sup>Ⓜ</sup>	L	M	P <sup>Ⓜ</sup>	Q <sup>Ⓜ</sup>	L	P <sup>Ⓜ</sup>	Q
Max Rated Voltage <sup>Ⓜ</sup>	Max	-	Vac	400	400	400	400	240	400	400	400	400	400	400	400
			Vdc	560	560	560	560	320	560	560	560	560	560	560	560
Continuous Torque for ΔT winding = 95°C <sup>Ⓜ②⑦⑧⑨</sup>	Nom	T <sub>CS</sub>	Nm	29.0	29.2	29.2	28.7	28.7	41.0	41.0	40.4	40.4	52	51	51
			lb-in	256	258	258	254	254	363	362	357	358	458	452	451
Continuous Current for ΔT winding = 95°C <sup>Ⓜ②⑦⑧⑨</sup>	Nom	I <sub>CS</sub>	A <sub>RMS</sub>	9.0	11.3	12.7	18.3	22.9	11.8	13.3	19.0	24.0	12.6	18	25.5
Continuous Torque for ΔT winding = 60°C <sup>Ⓜ</sup>	Nom	T <sub>CS</sub>	Nm	23.2	23.4	23.4	23.0	23.0	32.8	32.8	32.3	32.3	41.6	40.8	40.8
			lb-in	205	207	207	204	204	290	290	286	286	368	361	361
Max Mechanical Speed <sup>Ⓜ⑤⑥</sup>	Nom	N <sub>max</sub>	rpm	6000	6000	6000	6000	6000	6000	6000	6000	6000	6000	6000	6000
Peak Torque <sup>Ⓜ②</sup>	Nom	T <sub>p</sub>	Nm	79	79	80	78.0	78	112	112	111	111	143	141	141
			lb-in	699	699	708	690	690	1000	991	982	982	1266	1248	1248
Peak Current	Nom	I <sub>p</sub>	A <sub>RMS</sub>	27.9	34.5	39.0	56	71	36.3	40.8	59	74	38.5	55	78
75 Vdc Rated Torque (speed) <sup>Ⓜ②⑦⑧⑨</sup>		T <sub>rtd</sub>	Nm	-	-	-	-	-	-	-	-	-	-	-	-
			lb-in	-	-	-	-	-	-	-	-	-	-	-	-
Rated Speed		N <sub>rtd</sub>	rpm	-	-	-	-	-	-	-	-	-	-	-	-
Rated Power (speed) <sup>Ⓜ②⑦⑧⑨</sup>		P <sub>rtd</sub>	kW	-	-	-	-	-	-	-	-	-	-	-	-
			Hp	-	-	-	-	-	-	-	-	-	-	-	-
120 Vac (160 Vdc) Rated Torque (speed) <sup>Ⓜ②⑦⑧⑨</sup>		T <sub>rtd</sub>	Nm	-	-	-	-	-	-	-	-	-	-	-	-
			lb-in	-	-	-	-	-	-	-	-	-	-	-	-
Rated Speed		N <sub>rtd</sub>	rpm	-	-	-	-	-	-	-	-	-	-	-	-
Rated Power (speed) <sup>Ⓜ②⑦⑧⑨</sup>		P <sub>rtd</sub>	kW	-	-	-	-	-	-	-	-	-	-	-	-
			Hp	-	-	-	-	-	-	-	-	-	-	-	-
240 Vac (320 Vdc) Rated Torque (speed) <sup>Ⓜ②⑦⑧⑨</sup>		T <sub>rtd</sub>	Nm	-	-	-	22.8	22.1	-	-	33.2	32.0	-	-	40.2
			lb-in	-	-	-	202	196	-	-	294	283	-	-	356
Rated Speed		N <sub>rtd</sub>	rpm	-	-	-	1800	2000	-	-	1300	1500	-	-	1300
Rated Power (speed) <sup>Ⓜ②⑦⑧⑨</sup>		P <sub>rtd</sub>	kW	-	-	-	4.30	4.63	-	-	4.52	5.0	-	-	5.47
			Hp	-	-	-	5.77	6.2	-	-	6.1	6.7	-	-	7.34
400 Vac (560 Vdc) Rated Torque (speed) <sup>Ⓜ②⑦⑧⑨</sup>		T <sub>rtd</sub>	Nm	24.1	23.2	22.6	20.6	-	33.1	32.4	26.7	26.2	42.2	35.5	29.2
			lb-in	213	205	200	182	-	293	287	236	232	373	314	258
Rated Speed		N <sub>rtd</sub>	rpm	1500	1800	2000	2500	-	1400	1500	2400	2500	1200	1800	2500
Rated Power (speed) <sup>Ⓜ②⑦⑧⑨</sup>		P <sub>rtd</sub>	kW	3.79	4.37	4.73	5.4	-	4.86	5.1	6.7	6.9	5.3	6.7	7.6
			Hp	5.08	5.86	6.34	7.2	-	6.5	6.8	9.0	9.2	7.1	9.0	10.2

See following page for notes.



- Motor performance across the entire speed range varies depending on the selection of feedback device and holding brake.
- The on-line [Performance Curve Generator](#) provides the most accurate information for specific models.
  - A Kollmorgen account and login is required to use this design tool.

## 8.4 AKME7 - Servo Motor Parameters

Parameters	Tol	Symbol	Units	AKME72					AKME73				AKME74		
				K	L	M	P	Q	L	M	P	Q	L	P	Q
Torque Constant ①	±10%	$K_t$	Nm/A <sub>rms</sub>	3.23	2.62	2.33	1.58	1.26	3.49	3.11	2.13	1.69	4.14	2.84	2
			lb-in/A <sub>rms</sub>	28.6	23.2	20.6	14	11.2	31	27.4	18.9	15	36.6	25.1	17.7
Back EMF Constant ②	±10%	$K_e$	V <sub>rms</sub> /krpm	208	169	150	102	81	225	200	137	109	266	183	129
Motor Constant	Nom	$K_m$	N-m/√W	2.261	2.21	2.29	2.18	2.08	2.93	2.903	2.82	2.67	3.51	3.38	3.27
			lb-in/√W	20.02	19.6	20.25	19.3	18.4	25.9	25.66	25	23.6	31	29.9	28.9
Resistance (line-line) ⑥	±10%	$R_m$	ohm	1.36	0.92	0.69	0.35	0.23	0.95	0.76	0.38	0.25	0.93	0.47	0.24
Inductance (line-line)		L	mH	20.7	13.6	10.8	5	3.2	15.7	12.4	5.9	3.7	16.4	7.7	3.8
Inertia (includes Resolver feedback) ③	±10%	$J_m$	kg-cm <sup>2</sup>	65					92				120		
			lb-in-s <sup>2</sup>	0.057					0.082				0.11		
Optional Brake Inertia (additional) ④	±10%	$J_m$	kg-cm <sup>2</sup>	1.589					1.589				1.589		
			lb-in-s <sup>2</sup>	1.41E-03					1.41E-03				1.41E-03		
Weight (w/o brake) ⑤		W	kg	19.7					26.7				33.6		
			lb	43.4					58.8				74		
Static Friction ①		$T_f$	Nm	0.41					0.49				0.58		
			lb-in	3.61					4.31				5.11		
Viscous Damping ①		$K_{dv}$	Nm/krpm	0.06					0.13				0.2		
			lb-in/krpm	0.5					1.2				1.8		
Thermal Time Constant		TCT	minutes	46					53				60		
Thermal Resistance		$R_{thw-a}$	°C/W	0.39					0.33				0.3		
Operating Ambient Temperature Range ⑧⑨			°C	5 to 40					5 to 40				5 to 40		
Pole Pairs				5					5				5		
Heat Sink Size				18"x18"x1/2" Aluminum Plate					18"x18"x1/2" Aluminum Plate				18"x18"x1/2" Aluminum Plate		

Additional windings may exist. Please contact Kollmorgen Customer Support for further information or to request custom winding options for your application requirements.

### Notes:

① Motor winding temperature rise,  $\Delta T=95^\circ\text{C}$ , at  $40^\circ\text{C}$  ambient.

② All data referenced to sinusoidal commutation.

③ Add parking brake if applicable for total inertia.

④ Motor with standard heat sink.

⑤ May be limited at some values of V<sub>bus</sub>.

⑥ Measured at  $25^\circ\text{C}$ .

⑦ Brake option reduces continuous torque ratings by 1 Nm.

⑧ Non-Resolver feedback options reduce continuous torque ratings by:

AKME72 = 2.0 Nm AKME73 = 2.7 Nm AKME74 = 3.4 Nm

⑨ Motors with non-resolver feedback and brake option, reduce continuous torque by by:

AKME72 = 3.9 Nm AKME73 = 5.1 Nm AKME74 = 6.2 Nm

⑩ Brake option increases weight by 3.14 kg (6.92 lb).

⑪ If compliance to UL 508 is required, then any winding above 16 Arms/Phase continuous current rating, requires M40 "H" connector. Future UL60079 certification will provide guidance. Please contact Kollmorgen Customer Service for co-engineered solution evaluation.

⑫ Motors can be operated up to 400 Vac. For performances curves at voltages, listed or unlisted, please use our online Performance Curve Generator Tool.

⑬ Brake option will operate in this range in a non-condensing environment. See the Brake Option section for more information.

⑭ The applied holding brake voltage must be limited to 17 V to maintain ATEX/IECEx T4 temperature class compliance.

⑮ For AKME7 the maximum speed is limited up to 2500 rpm.

## 9 AKME - Feedback Specifications

---

9.1 AKME - Feedback Unit Options .....	116
9.2 Kollmorgen Smart Feedback Device, Multi-turn (SFD-M) (CB) .....	116
9.3 AKME - Commutating Encoder Options .....	117
9.4 AKME - HIPERFACE Options .....	118
9.4.1 HIPERFACE DSL Capacitive (GU) .....	118
9.4.2 HIPERFACE Absolute Sin/Cos Encoder (GJ, GK) .....	118
9.5 AKME - Optical Sine Encoder Options .....	119
9.5.1 EnDat Optical (DA, DB) .....	119
9.5.2 BiSS Optical (AA, AB) .....	119
9.6 AKME - Resolver Options .....	119

## 9.1 AKME - Feedback Unit Options

### Feedback Unit Options

■ Safety Capable

				Feedback Resolution				
Code	Designation	AKME Frame Size	Single-Turn or Multi-Turn	Device Resolution (Sin/Cos per Rev., Bits or Lines/Rev.)	AKD Internal Resolution	AKD2G Internal Resolution	# of Absolute Revs.	Accuracy (± arc-mins)
2-	Commutating Encoder	2-7	Single-turn	2048 Lines	8,192	8,192	None	1
AA	BISS B Optical Sine Encoder	2-7	Single-turn	2048 Sin/Cos	27-Bits	32-Bits	1	0.6
AB		2-7	Multi-turn				4,096	
CB	SFD-M Smart Feedback Device, Multi-turn	2-6	Multi-turn	24-Bits	24-Bits	24-Bits	65,536	1
GU*	HIPERFACE DSL® Optical Encoder	2-6	Multi-turn	17-Bits	18-Bits	18-Bits	4,096	4
GJ	HIPERFACE Optical Sin/Cos Encoder	2-7	Single-turn	128 Sin/Cos	23-Bits	31-Bits	1	1.33
GK			Multi-turn				4,096	
DA	EnDat® 2.2/01 Optical Sine Encoder	2-4	Single-turn	512 Sin/Cos	25-Bits	32-Bits	1	1
		5-7		2048 Sin/Cos	27-Bits			0.333
DB		2-4	Multi-turn	512 Sin/Cos	25-Bits	4,096	4,096	1
		5-7		2048 Sin/Cos	27-Bits			0.333
R-	Resolver Inductive Encoder	2-4	Single-Turn	1 pole pair (16-Bits)	16-Bits	16-Bits	1	10
		5-7						9

\* SICK HIPERFACE DSL® model EEM37-2KF0A017A. Please visit <https://www.sick.com> to download the latest safety data sheet.

## 9.2 Kollmorgen Smart Feedback Device, Multi-turn (SFD-M) (CB)

### Kollmorgen Smart Feedback Device, Multi-turn (SFD-M) (CB)

The SFD-M Feedback uses a single motor cable, requiring just one cable between the drive and motor.

The feedback has both power and communication on a single wire pair, reducing overall wiring costs. SFD-M offers 24-bit absolute single-turn resolution, batteryless 16-bit (65,536) multi-turn absolute revolutions and an absolute angular accuracy of +/- 1 arc-min.

In addition, the device includes onboard memory for an electronic motor datasheet which enables device auto-recognition for faster setup and commissioning when paired with any Kollmorgen KED, AKD or AKD2G drive.

#### Angle Measurement:

Single-Turn Resolution:  $2^{24} = 16,777,216$  counts per rev

Multi-Turn Absolute Range:  $2^{16} = 65,536$  absolute revolutions\* (batteryless)

Accuracy: < +/- 1 arc-min typical 25 °C  
< +/- 3 arc-min worst case

Electrical Noise: <  $2^{-22}$  Rev rms at full bandwidth

Bandwidth: > 2 kHz at -3 dB  
> 1 kHz at -45° phase lag

Max Continuous Speed: 10,000 RPM

Velocity Ripple: < 1% p-p (typical)

Velocity Noise: < 0.3 RPM rms at full bandwidth

#### Power Supply:

Input Voltage: 7 V - 12 V accepted (at motor terminals)

Input current maximum: 140 mA DC

#### Digital Communications:

Baud rate: 2.5 Mbaud

Signaling: RS-485 differential using differential Manchester encoding

Update period: New position sample every 51.2 μs

Error detection: 5-bit CRC and running parity check

#### Environmental:

Feedback Operating Temperature: -40 to 120 °C

Humidity: 10% to 90% non-condensing

Vibration Resistance: 30g (294 m/s<sup>2</sup>) @ 55-2000 Hz (EN60068-2-6)

Shock Resistance: 100g (981 m/s<sup>2</sup>) @ 6 ms (EN60068-2-27)

\* When paired with AKD, this is limited to 4096 absolute revolutions (12-bits)

### 9.3 AKME - Commutating Encoder Options

#### Commutating Encoder (2-)

Parameter	Units	2-
Frame Size		AKME2-7
Input Voltage	Vdc ±10%	5
Output Data	-	TTL Differential Line Driver (Sink/Source 20mA MAX.)
Line Count per revolution	-	2,048
Frequency Response	KHz	200
Max. Speed	RPM	12,000
Min. Edge Separation of Incremental Channel	°e MIN.	45
Index to U Comm Channel	-	±1°m Index Center to U Falling Edge
Index Pulse Width	-	Gated With B Low
Incremental Channel Accuracy	-	±1 Arc Min. Max. Edge to Edge
Max. Acceleration	Rad/s <sup>2</sup>	100,000
Feedback Operating Temperature	°C	-20 to 120
Storage Temperature	°C	-25 to 120

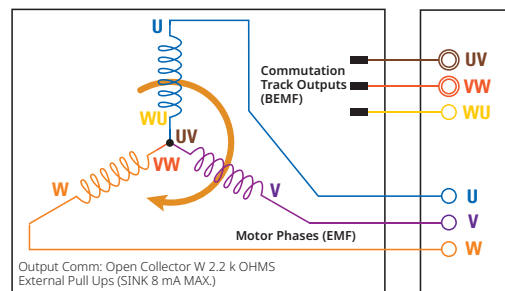
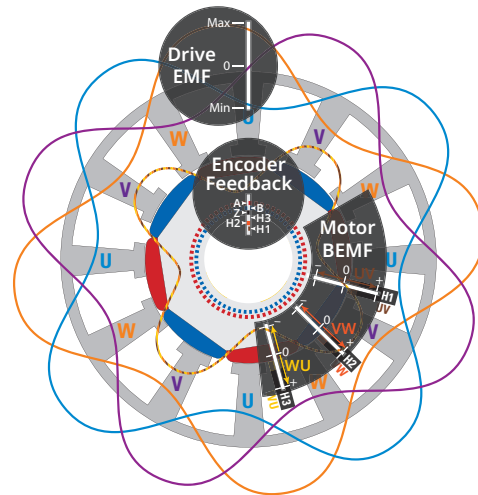
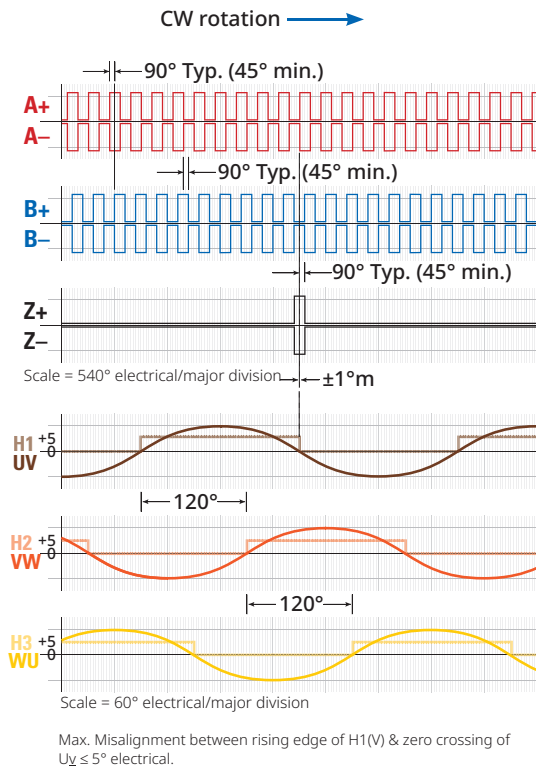

## 9.4 AKME - HIPERFACE Options

### 9.4.1 HIPERFACE DSL Capacitive (GU)

#### HIPERFACE DSL® Capacitive (GU)

Type		Multi-Turn "GU"
Frame Size		AKME 2-7
Number of Absolute Ascertainable Revolutions		4096
Supply Voltage Range	Vdc	7 to 12
Current Consumption	mA MAX.	150
Operating Temperature	°C MIN./MAX.	-40/115
Inertia	kg-cm <sup>2</sup>	0.001
Output Interface		SICK HIPERFACE DSL®
Vibration Resistance – EN 60068-2-6	g [m/s <sup>2</sup> ]	50 g [490 m/s <sup>2</sup> ] – 10 to 2000 Hz
Shock Resistance – EN 60068-2-27	g [m/s <sup>2</sup> ]	≤100 g [981 m/s <sup>2</sup> ] – 6 ms
Manufacturer Product Type		EEM37-2KF0A017A*

Functional Safety Capable \*Sick HIPERFACE DSL® model EEM37-2KF0A017A. Please visit <https://www.sick.com> to download the latest safety data sheet.

### 9.4.2 HIPERFACE Absolute Sin/Cos Encoder (GJ, GK)

#### HIPERFACE Absolute Sin/Cos Encoder (GJ, GK)

Type		Single-Turn "GJ"	Multi-Turn "GK"
Frame Size		AKME 2-7	AKME 2-7
Sin/Cos period per revolution	-	128	128
Input Voltage	Vdc	7 to 12	7 to 12
Current Consumption	mA Typical	60	60
Feedback Operating Temperature	°C MIN./MAX.	-20/110	-20/110
Inertia	kg-cm <sup>2</sup>	0.0045	0.0045
Output Interface		Sick Absolute Hiperface Sin/Cos Encoder	
Manufacturer Product Type		SKS36	SKM36

Note: GJ/GK Feedbacks are "mapped" for AKD/AKD2G Series drives.

## 9.5 AKME - Optical Sine Encoder Options

### 9.5.1 EnDat Optical (DA, DB)

#### EnDat Optical (DA, DB)

Type		Single-Turn "DA"		Multi-Turn "DB"	
Frame Size		AKME 2-4	AKME 5-7	AKME 2-4	AKME 5-7
Cycles per Revolution (# of abs. revs.)	-	512 (1)	2048 (1)	512 (4096)	2048 (4096)
Input Voltage	Vdc	3.6 to 14	3.6 to 14	3.6 to 14	3.6 to 14
Current Consumption	mA Typical	85 (no load)	85 (no load)	105 (no load)	105 (no load)
Feedback Operating Temperature	°C MIN./MAX.	-40/115	-40/115	-40/115	-40/115
Inertia	kg-cm <sup>2</sup>	0.04	0.026	0.04	0.026
Output Interface		HEIDENHAIN EnDat 2.2/01			
Manufacturer Product Type		ECN1113	ECN1313	EQN1125	EQN1325

**Encoder Alignment:** With positive DC current into phase W and out of phase V (U floats) the encoder is aligned to ±1 electrical degree.

### 9.5.2 BiSS Optical (AA, AB)

#### BiSS Optical (AA, AB)

Type		Single-Turn "AA"		Multi-Turn "AB"	
Frame Size		AKME 2-4	AKME 5-7	AKME 2-4	AKME 5-7
Cycles per Revolution (# of abs. revs.)	-	2048 (1)	2048 (1)	2048 (4096)	2048 (4096)
Input Voltage	Vdc (tolerance)	5 (-5%/+10%)	5 (± 10%)	5 (-5%/+10%)	5 (± 10%)
Current Consumption	mA Typical	100 (without load)	100 (without load)	150 (without load)	100 (without load)
Feedback Operating Temperature	°C MIN./MAX.	-15/120	-15/120	-15/120	-15/120
Inertia	kg-cm <sup>2</sup>	0.025	0.038	0.025	0.038
Output Interface		BiSS B			
Manufacturer Product Type		AD34	AD58	AD34	AD58

**Encoder Alignment:** With positive DC current into phase W and out of phase V (U floats) the encoder is aligned to ±1 electrical degree.

## 9.6 AKME - Resolver Options

#### Resolver (R-)

Type		R- 1 Speed	
Frame Size		AKME2-4	AKME5-7
Input Voltage	V <sub>RMS</sub>	8 (± 5%)	8 (± 5%)
	k Hz	8 (± 1%)	8 (± 1%)
Input Current Max.	mA	50	46
Transformation Ratio	N/A	0.5	0.5
Null Voltage	mV <sub>RMS</sub>	30	30
Max. Error (pk-pk)	MINS.	20	18
Phase Shift	Degrees	0	0
Operating Temperature	°C	-55° to 155°	-55° to 155°
Rotor Inertia Max.	kg-cm <sup>2</sup>	0.046	0.497
Vibration and Shock Resistance		High Vibration and Shock Resistance Please contact Kollmorgen Customer Support	

#### Resolver Alignment

With positive DC current into phase W and out of phase V (U floats), the resolver is aligned. ie. Voltage S1-S3 set to null and voltage S2-S4 max in phase with reference (R1-R2).

#### Resolver Winding Configuration

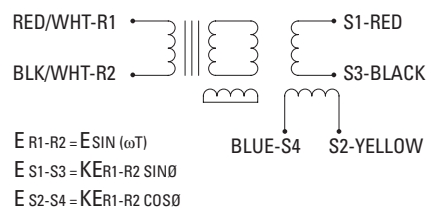

## 10 AKME - Connector Pinouts

---

10.1 AKME - Connector Options .....	121
10.2 AKME - 9- Hybrid Connector Pinouts - Power and Feedback .....	121
10.3 AKME - Feedback Connectors .....	122
10.4 AKME - 4-, W-, Power Connector Pinouts - Power and Feedback .....	123

## 10.1 AKME - Connector Options

### Connector Options

Code	Thermal Sensor*	Used with	IP Rating**	Connection type	Description
4	PT1000	AKME2-AKME7	IP67	2 threaded connectors, size 1.0 (M23)	Angled, rotatable, mounted on motor
9		AKME2-AKME6	IP67	1 threaded connector, size 1.0 (M23)	Angled, rotatable, mounted on motor
W		AKME7	IP67	1 feedback threaded connector, size 1.0 (M23) 1 power threaded connector, size 1.5 (M40)	Angled, rotatable, mounted on motor

\*For Thermal Device Curves, reference see the Thermal Sensor Protective Devices page.

\*\*IP ratings shown apply ONLY to the connector and the connector base/bushing on motor.

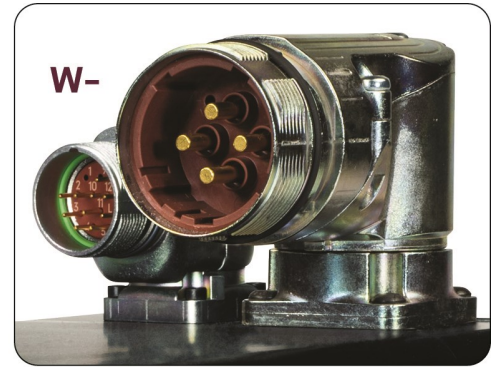

## 10.2 AKME - 9- Hybrid Connector Pinouts - Power and Feedback

### 9- Hybrid Connector Pinout

#### 9- Connector Pinout - Hybrid combined power, brake, and SFD-M / HDSL feedback

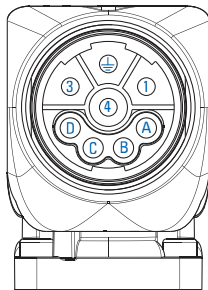

PHOENIX  
Power + SFD-M / HDSL Connector  
P/N: 1620660  
Mating Connector P/N: 1605617

#### Power + SFD-M / HDSL

Pin	Function
1	U
⊕	PE
3	W
4	V
A	Brake +
B	Brake -
C	SFD-M - / HDSL -
D	SFD-M + / HDSL +

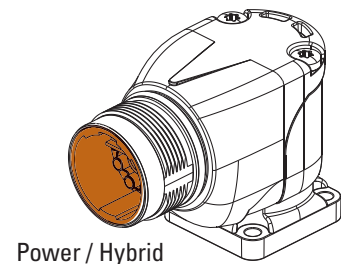

Power / Hybrid

9- Connector

## 10.3 AKME - Feedback Connectors

### 4- and W- Feedback Connector Pinouts

4- Connectors  
(AKME2-7 ≤ 20 A Only)

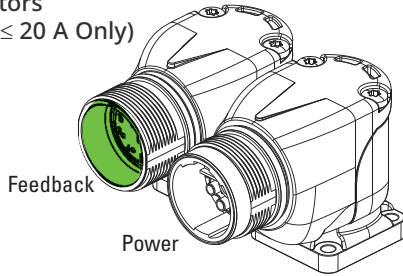

W- Connectors  
(AKME7 > 20 A Only)

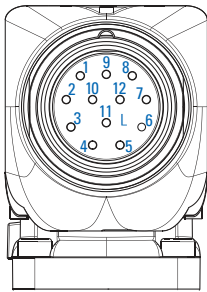
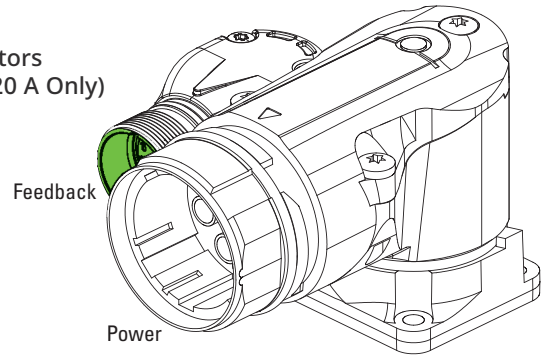

PHOENIX

12-pin Feedback Connector  
P/N: 1607257

Mating Connector P/N: 1069313

#### Resolver

Pin	Function
1	N/C
2	PT1000 +
3	S4 COS -
4	S3 SIN -
5	R2 REF -
6	PT1000 -
7	S2 COS +
8	S1 SIN +
9	R1 REF +
10	N/C
11	N/C
12	N/C

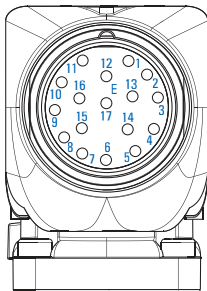

PHOENIX

17-pin Feedback Connector  
P/N: 1607328

Mating Connector P/N: 1619754

#### Commutating Encoder

Pin	Function
1	B +
2	B -
3	A +
4	A -
5	Z +
6	Z -
7	GND
8	PT1000 +
9	PT1000 -
10	Vcc
11	N/C
12	N/C
13	N/C
14	N/C
15	U
16	V
17	W

#### EnDat®/BiSS

Pin	Function
1	B -
2	GND
3	A -
4	Vcc
5	DATA +
6	N/C
7	PT1000 +
8	Clock +
9	B +
10	Un Sense (Common)
11	A +
12	Up Sense (VCC)
13	DATA -
14	PT1000 -
15	Clock -
16	N/C
17	N/C

#### HIPERFACE® Analog

Pin	Function
1	SIN +
2	GND
3	COS +
4	Up Sense (VCC)
5	DATA +
6	N/C
7	PT1000 +
8	N/C
9	REF SIN -
10	N/C
11	REF COS -
12	N/C
13	DATA -
14	PT1000 -
15	N/C
16	N/C
17	N/C

## 10.4 AKME - 4-, W-, Power Connector Pinouts - Power and Feedback

### 4- Power Connector Pinout

4- Connectors (AKME2-7 ≤20 A Only)

Pin	Function
1	U
⊕	PE
3	W
4	V
A	Brake +
B	Brake -
C	N/C
D	N/C

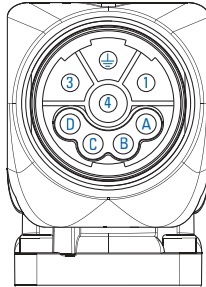

**PHOENIX**  
Power Connector  
P/N: 1620660  
Mating Connector P/N: 1605617

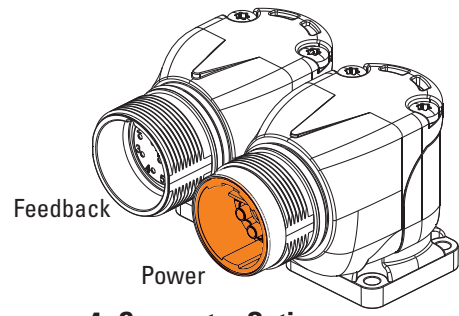

**4- Connector Option**

### W- Power Connector Pinout

(AKME7xQ > 20 A Only)

Pin	Function
U	U
V	V
W	W
⊕	PE
+	Brake +
-	Brake -
1-2	N/C

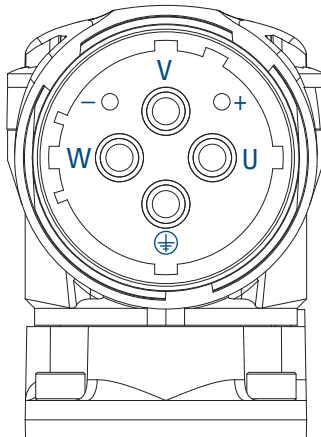

**INTERCONTEC**  
Power Connector  
P/N: CEDE-270-NN-00-00-0051-000  
Mating Connector P/N: CSTA-263-NN-00-26-0001-000

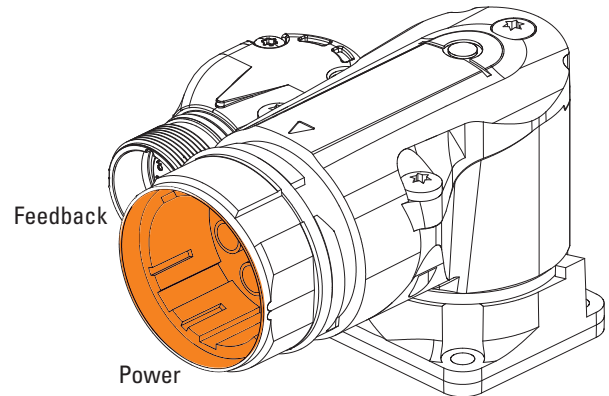

**W- Connector Option**

## 11 AKME - Cables

**! IMPORTANT**

The use of Kollmorgen pre-assembled cables is required to maintain AKME ATEX / IECEx compliance.

---

11.1 AKME - Cable Properties .....	125
11.2 AKME - Cable Part Number Scheme .....	126
11.3 AKME - AKD - Hybrid Cables .....	127
11.4 AKME - AKD2G - Hybrid Cables .....	128
11.5 AKME - Kollmorgen Essentials™ - Hybrid Cables .....	129
11.6 AKME - AKD - Power Cables .....	130
11.7 AKME - AKD2G - Power Cables .....	131
11.8 AKME - AKDxx - Feedback Cables .....	132

## 11.1 AKME - Cable Properties

Test Voltage	3kV <sub>AC</sub>
Operating Voltage	1000V <sub>AC</sub>
Temperature Range	-40 °C to +90 °C Static / Dynamic / Storage
Minimum Bending Radius - Dynamic	7.5x Diameter
Maximum Speed	300 m/min.
Maximum Acceleration	50 m/s <sup>2</sup>
Maximum Torsion	30°/m
Maximum Number of Cycles	5,000,000
Flame Resistance	<ul style="list-style-type: none"> <li>• CSA FT1</li> <li>• EN 50265-1-2</li> <li>• IEC 60332-1-2</li> <li>• UL VW-1</li> </ul>
Halogen Free	<ul style="list-style-type: none"> <li>• EN 50267-2-1</li> <li>• IEC 60754-1</li> </ul>
Hydrocarbons and Oil Resistance	UL 1581-VDE0472 part 803 A/B

## 11.2 AKME - Cable Part Number Scheme

**! IMPORTANT**

- The part number scheme is for product identification only.
- Do not use for the order process because not all combinations of features are possible.

**H2 - 12 - 015 - A1 - 00 - XXXX00**

**Cable Version**

**Cable Jacket Material - PUR**

- F1 Mid-flex Feedback Cable PUR
- H2 Mid-flex Hybrid PUR with brake
- P2 Power Cable PUR with brake

**Connector Type**

**If Feedback, connector type [connector type and pinout]**

- 10 AKD, AKD2G, 15 Pin D-Sub, 45° angle, Resolver
- 12 AKD, AKD2G, 15 Pin D-Sub, 45 degree angle, EnDat® 2.1, BiSS B
- 14 AKD, AKD2G, 15 Pin D-sub, 45 degree angle, HIPERFACE®
- 20 AKD, AKD2G, 15 Pin D-sub, 45 degree angle, Comcoder, Sine Enc. w/ Halls

**If Power or Hybrid drive connector type**

- 11 AKD-x00306, -x00606 (Power and Hybrids with HDSL, SFD3/SFD-M)
- 12 AKD-x01206, -x02406 (Power and Hybrids with HDSL, SFD3/SFD-M)  
AKD-x00307, -x00607, -x01207, -x02407 (Power and Hybrids with HDSL, SFD3/SFD-M)
- 21 AKD2G-x00306, -x00606, -x01206  
AKD2G-x00307, -x00607, -x01207, -x02406, -x02407
- 51 KED MV3/6 (Hybrid with SFD-M/SFD-3 and HDSL)
- 52 KED MV12 (Hybrid with SFD-M/SFD-3 and HDSL)

**Length (no less than 100 mm increments)**

xxxx00 Length in mm  
Standard lengths: 1 - 25 m  
VL offered in 3, 6, 9, 12m only w/o PLM approval  
Example:  
6 m cable = 006000  
25 m cable = 025000

**Options**

- 00 Standard Option Set
- XX Specials (excluding standard option set)

**Motor Mating Connector Type**

**Hybrid / Power Connectors (#Pins)**

- A7 AKM1G, AKME M40 SpeedTec (6)
- D1 AKME, M23 Phoenix

**Feedback Connectors**

- A4 AKME, M23 (12)
- A5 AKME, M23 (17)

**Cable Type**

**If Feedback, type [cable construction, not pinout]**

- FB2 8 Conductor
- FB4 16 Conductor
- FB6 10 Conductor

**If Power or Hybrid drive connector type**

- 010 1.0 mm<sup>2</sup>
- 015 1.5 mm<sup>2</sup>
- 025 2.5 mm<sup>2</sup>
- 040 4.0 mm<sup>2</sup>
- 060 6.0 mm<sup>2</sup> (power only)

### 11.3 AKME - AKD - Hybrid Cables

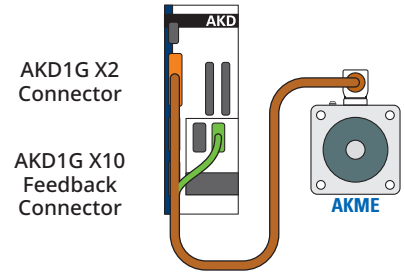

#### AKME Motor to AKD® Drive Hybrid Cable Part Numbers

Drive	Motor Feedback	Motor Connector	All with Brake		Hybrid Cable
			Cross Section, mm <sup>2</sup>	Current Rating* (A)	
AKD	SFD-M (CB) HIPERFACE DSL (GU)	Single Hybrid, M23	1.5	13.1	H2-11-015-D1-00-XXXX00
			2.5	17.4	H2-12-025-D1-00-XXXX00
			4.0	23	H2-12-040-D1-00-XXXX00

\* Current ratings used on a EN60204-1 standard

#### AKME to AKD® Power Cable Pinouts

##### Power ± Brake

AKD X2	Function	AKME M23
BR-	Brake -	D
BR+	Brake +	C
PE	PE	⊕
U / U2	Phase U	1
V / V2	Phase V	3
W / W2	Phase W	4

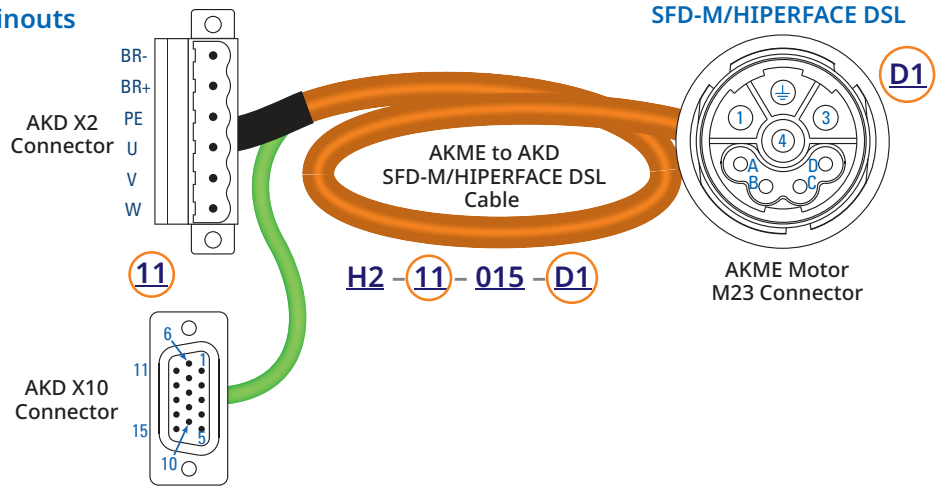

##### SFD-M/HIPERFACE DSL

AKD X10	Function	AKME M23
6	SFD-M/HDSL+	A
7	SFD-M/HDSL-	B

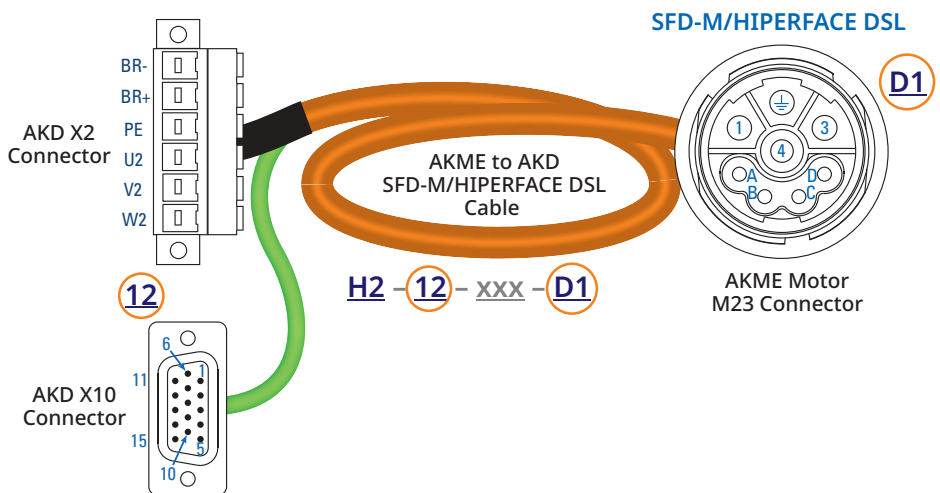

## 11.4 AKME - AKD2G - Hybrid Cables

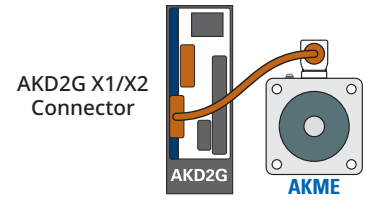

### AKME Motor to AKD<sup>®</sup>2G Servo Drive Hybrid Cable Part Numbers

Drive	Motor Feedback	Motor Connector	All with Brake		Hybrid Cable
			Cross Section, mm <sup>2</sup>	Current Rating* (A)	
AKD2G	SFD-M (CB) HIPERFACE DSL (GU)	Single Hybrid, M23	1.5	13.1	H2-21-015-D1-00-XXXX00
			2.5	17.4	H2-21-025-D1-00-XXXX00
			4.0	23	H2-21-040-D1-00-XXXX00

\* Current ratings used on a EN60204-12 standard

### AKME to AKD<sup>®</sup>2G Hybrid Cable Pinouts

Power ± Brake + SFD-M/HDSL

AKD2G X1/X2	Function	AKME M23
1	Phase U	1
2	Phase V	3
3	Phase W	4
Retention Latch, Shield Screw		
5	PE	⊕
B+	Brake +	A
B-	Brake -	B
F+	SFD-M/HDSL+	C
F-	SFD-M/HDSL-	D

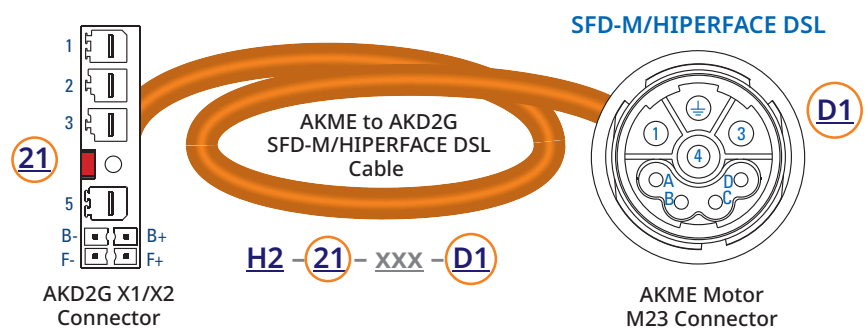

## 11.5 AKME - Kollmorgen Essentials™ - Hybrid Cables

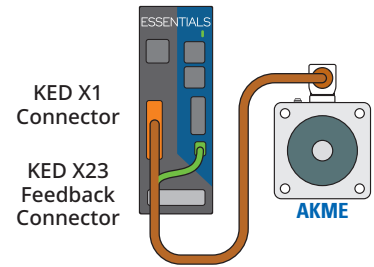

### AKME Motor to Kollmorgen Essentials Drive Hybrid Cable Part Numbers

Drive	Motor Feedback	Motor Connector	All with Brake		Hybrid Cable
			Cross Section, mm <sup>2</sup>	Current Rating* (A)	
KED-6V03S, 6V06S	SFD-M (CB)	Single Hybrid, M23	1.5	13.1	H2-51-015-D1-00-XXXX00
KED-6V12S, 7VXXS			1.5	13.1	H2-52-015-D1-00-XXXX00
			2.5	17.4	H2-52-025-D1-00-XXXX00

\* Current ratings used on a EN60204-12 standard

### AKME to Kollmorgen Essentials Hybrid Cable Pinouts

#### Power ± Brake

KED X1	Function	AKME M23
BR-	Brake +	D
BR+	Brake -	A
PE	PE	⊕
U	Phase U	U
V	Phase V	V
W	Phase W	W

#### SFD-M Feedback

KED X23	Function	AKME M23
1	SFD-M -	C
2	SFD-M +	D

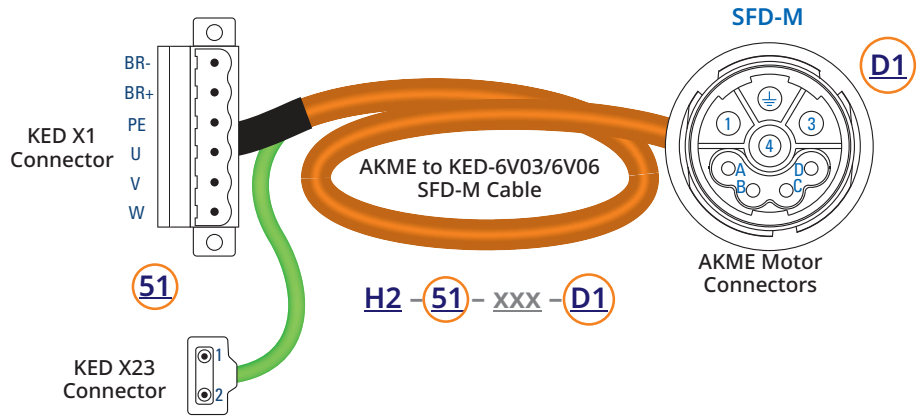

#### Power ± Brake

KED X1/X23	Function	AKME M23
BR-	Brake +	D
BR+	Brake -	A
PE	PE	⊕
Retention Latch		
U	Phase U	U
V	Phase V	V
W	Phase W	W

#### SFD-M Feedback

KED X23	Function	AKME M23
1	SFD-M -	C
2	SFD-M +	D

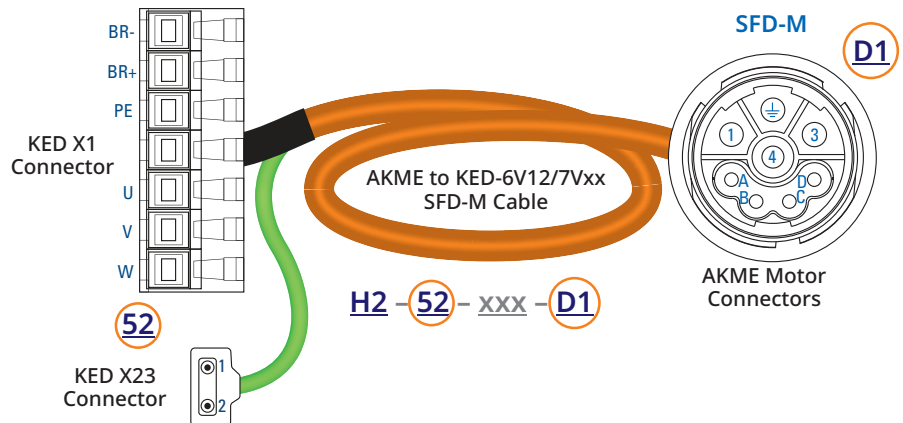

## 11.6 AKME - AKD - Power Cables

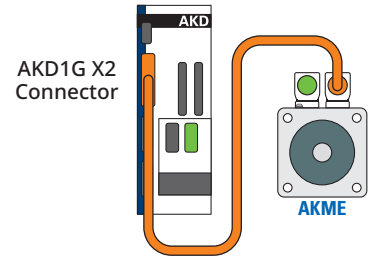

### AKME Motor to AKD® Drive Power Cable Part Numbers

Drive	Motor Connector	All with Brake		Power Cable
		Cross Section, mm <sup>2</sup>	Current Rating* (A)	
AKD	90° M23 Phoenix	1.0	10	P2-11-010-D1-00-XXXX00
		1.5	13.1	P2-12-015-D1-00-XXXX00
		2.5	17.4	P2-12-025-D1-00-XXXX00
	90° M40 SpeedTec	4.0	23	P2-12-040-D1-00-XXXX00
		6.0	30	P2-12-040-A7-00-XXXX00
				P2-12-060-A7-00-XXXX00

\* Current ratings used on a EN60204-12 standard

### AKME to AKD® Power Cable Pinouts

#### Power ± Brake

AKD X2	Function	AKME M23
BR-	Brake -	D
BR+	Brake +	C
PE	PE	⊕
U / U2	Phase U	1
V / V2	Phase V	3
W / W2	Phase W	4

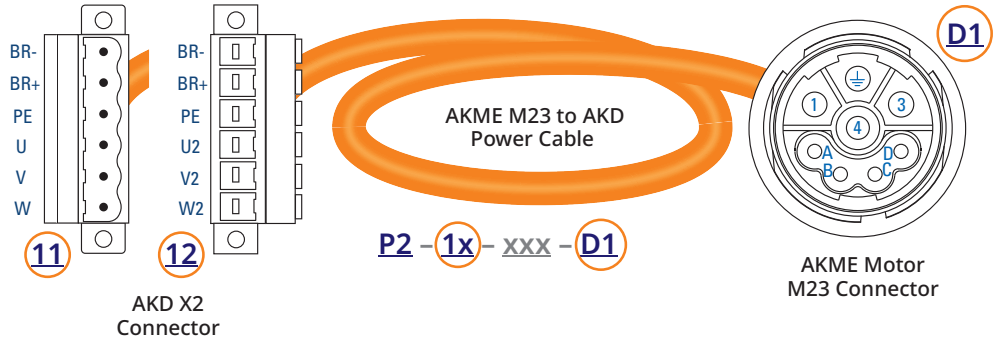

#### Power ± Brake

AKD X2	Function	AKME M40
BR-	Brake -	-
BR+	Brake +	+
PE	PE	⊕
U / U2	Phase U	U
V / V2	Phase V	V
W / W2	Phase W	W

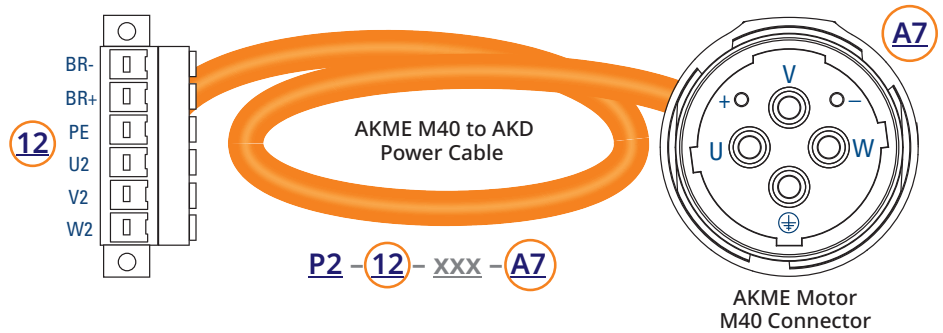

## 11.7 AKME - AKD2G - Power Cables

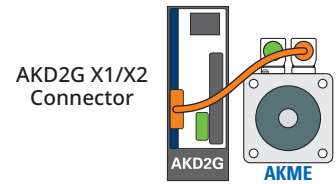

### AKME Motor to AKD2G Power Cable Part Numbers

Drive	Motor Connector	All with Brake		Power Cable
		Cross Section, mm <sup>2</sup>	Current Rating* (A)	
AKD2G	90° M23 Phoenix	1.5	13.1	P2-21-015-D1-00-XXXX00
		2.5	17.4	P2-21-025-D1-00-XXXX00
		4.0	23	P2-21-040-D1-00-XXXX00
	90° M40 SpeedTec	4.0	23	P2-21-040-A7-00-XXXX00
		6.0	30	P2-21-060-A7-00-XXXX00

\* Current ratings used on a EN60204-1 standard

### AKME to AKD2G Power Cable Pinouts

#### Power ± Brake

AKD2G X1/X2	Function	AKME M23
1	Phase U	1
2	Phase V	3
3	Phase W	4
Retention Latch, Shield Screw		
5	PE	⊕
B+	Brake +	A
B-	Brake -	B
F+	-	NC
F-	-	NC

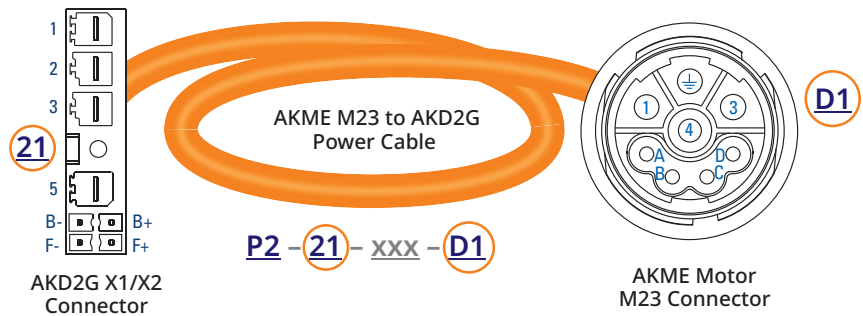

#### Power ± Brake

AKD2G X1/X2	Function	AKME M40
1	Phase U	U
2	Phase V	V
3	Phase W	W
Retention Latch, Shield Screw		
5	PE	⊕
B+	Brake +	+
B-	Brake -	-
F+	-	NC
F-	-	NC

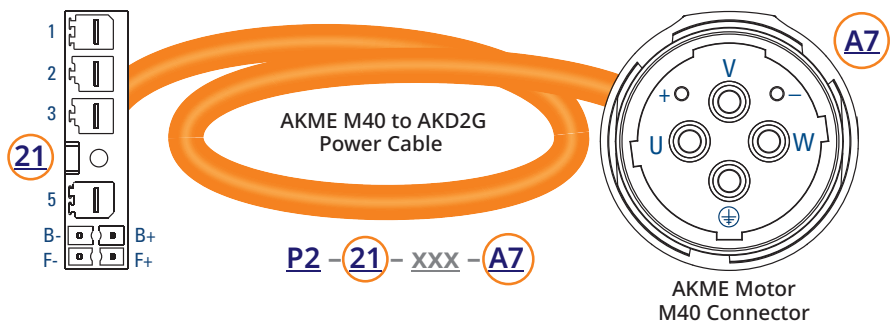

## 11.8 AKME - AKDxx - Feedback Cables

### AKME to AKD / AKD2G Feedback Cable Part Numbers

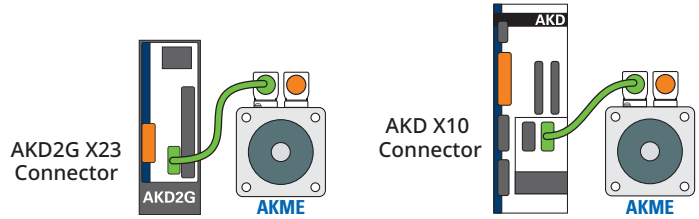

Drive	Feedback	Motor Connector	Pins	Feedback Cable
AKD AKD2G	Resolver	90° M23 Phoenix	12	F1-10-FB2-A4-00-xxxx00
	EnDAT / BiSS		17	F1-12-FB4-A5-00-xxxx00
	ComCoder			F1-20-FB4-A5-00-xxxx00
	HIPERFACE Analog			F1-14-FB6-A5-00-xxxx00

### AKME to AKD / AKD2G 12-pin Resolver Cable Pinout

#### Resolver

Drive 15-pin Dsub	Function	AKME 12-pin M23
6	R1 Ref+	9
7	R2 Ref-	5
8	TC (+)	2
9	TC (-)	6
12	S1 SIN+	8
13	S3 SIN-	4
14	S2 COS+	7
15	S4 COS-	3

### AKME to AKD / AKD2G 12-pin Resolver Cable

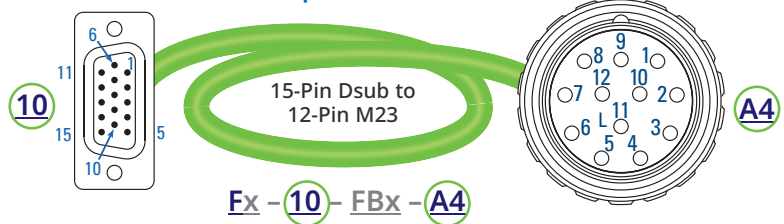

### AKME to AKD / AKD2G 17-pin Feedback Cable

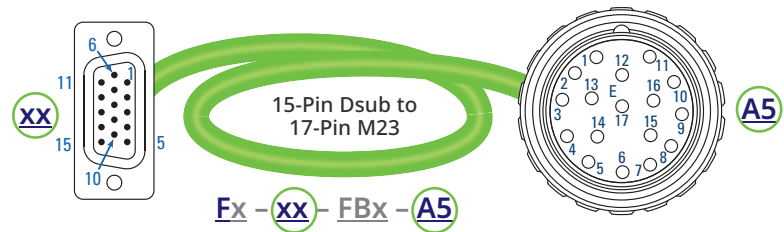

### AKME to AKD / AKD2G 17-pin Feedback Cable Pinouts

#### EnDAT / BiSS

Drive 15-pin Dsub	Function	AKME 17-pin M23
1	-	-
2	CLK+	8
3	CLK-	15
4	SEN+	12
5	SEN-	10
6	DAT+	5
7	DAT-	13
8	TC+	7
9	TC-	14
10	+5 V	4
11	0 V	2
12	A+ SIN+	11
13	A- SIN-	3
14	B+ COS+	9
15	B- COS-	1

#### ComCoder

Drive 15-pin Dsub	Function	AKME 17-pin M23
1	±Hall U	15
2	±Hall V	16
3	±Hall W	17
4	-	-
5	-	-
6	Zero+	5
7	Zero-	6
8	TC+	8
9	TC-	9
10	+5 V	10
11	0V	7
12	A+	3
13	A-	4
14	B+	1
15	B-	2

#### HIPERFACE Analog

Drive 15-pin Dsub	Function	AKME 17-pin M23
1	-	-
2	-	-
3	-	-
4	I	-
5		-
6	DAT+	5
7	DAT-	13
8	TC+	7
9	TC-	14
10	+8-9 V	4
11	0 V	2
12	A+ SIN+	1
13	A- SIN-	9
14	B+ COS+	3
15	B- COS-	11

## 12 Brakes - Technical Data

---

12.1 Failsafe, Holding Brake .....	134
12.2 Emergency Stops .....	134
12.3 Servo Motor Contamination .....	134
12.4 AKME Brake Data .....	135
12.5 Brake Notes .....	136
12.6 Time Needed to Achieve 90% of Static Torque .....	137
12.6.1 Brake Switching Cycle for AKD or AKD2G Drives .....	137
12.7 Holding Brake Functionality .....	138
12.8 Brake and Servo Motor Terminology .....	139
12.8.1 Brake Terms .....	139
12.8.2 Servo Motor Terms .....	140

## 12.1 Failsafe, Holding Brake

The holding brake is designed to provide static holding torque to the servo motor shaft with the brake coil de-energized.

- The brake must first be released (coil energized) prior to commanding servo motor rotation as determined by its drop-out time.
- The brake is intended for holding or parking of a stationary servo motor.
  - It is not intended for dynamic braking.
- There should be absolutely no motion of the rotor when power is removed from the brake coil.

## 12.2 Emergency Stops

The brake can be used for a limited number of emergency stop conditions.

- Such use will eventually cause wear, leading to eventual malfunction of the brake.
- The number of emergency stops strongly depends on applied load.
- Contact Kollmorgen for proper calculation of energy that needs to be absorbed during emergency stops in application.

## 12.3 Servo Motor Contamination

Contamination of the servo motor internal compartment by oil or other foreign materials results in failure of the brake.

Check the suitability of servo motor sealing for the working environment.

### NOTE

Contact "Support and Services" (→ p. 170) for detailed specifications and all other inquiries.

## 12.4 AKME Brake Data

\*\*Note Numbers are here: "Brake Notes" (→ p. 136).

Motor Family	Units	AKME2	AKME3	AKME4	AKME5	AKME6	AKME7	**Note Number
B <sub>10d</sub>	-	20,000,000			15,000,000			13, 15
Coil Resistance @ 25 °C	Ω ±7%	68.5	56.6	45.2	29.2	22.4	16.2	-
Current @ 24VDC, 25 °C	ADC	0.35	0.42	0.53	0.82	1.07	1.48	10
Friction Disc Inertia	kg.cm <sup>2</sup>	0.013	0.014	0.058	0.166	0.668	1.585	-
Maximum Acceleration	rad/s <sup>2</sup>	84500	60000	37000	15400	6800	5800	11, 12
Maximum Backlash	deg.	1.01	1.01	0.81	0.71	0.51	0.44	4, 5, 12
Maximum Release Current (New Brake), 25 °C	ADC	0.26	0.32	0.40	0.62	0.80	1.11	14
Maximum Release Voltage (New Brake)	VDC	18						2, 14
Maximum Speed	RPM	8000	8000	6000	6000	4750	4000	-
Minimum Dry Static Torque, 120 °C	Nm	1.42	2.5	5.3	14.5	25.0	53.0	1
Minimum Number of Springs	-	6	8	6	8	12	12	15, 16
Minimum Re-Engage Voltage (New Brake)	VDC	≥0.8			≥1.5			3, 14
Nominal Operating Voltage	VDC ±10%	24						-
Power Consumption @ 24VDC, 25 °C	Watt ±7%	8.41	10.18	12.74	19.73	25.71	35.56	-
Release (Opening) Time	ms	45	50	75	115	155	170	6, 7
Response Time (Engage/Closing)	ms	36	20	30	30	40	70	6, 8, 9
Response Time with AKD	ms	36	35	40	45	55	75	17
Temperature Range	°C	+5° C to 120° C						-
Total Torque Rise Time with AKD	ms	65	80	115	165	240	290	17, 18
Typical Backlash	deg.	0.46	0.46	0.37	0.31	0.24	0.20	4, 5, 12
Weight	kg	0.27	0.36	0.69	1.23	2.19	3.14	-

## 12.5 Brake Notes

Note #	Description
1	The maximum torque that can be applied to a brake without the risk of slipping.
2	<ul style="list-style-type: none"> <li>The value of voltage where the brake is 100% OPEN.</li> <li>The brake is mounted inside of the servo motor.</li> </ul>
3	<ul style="list-style-type: none"> <li>The value of voltage where the brake is 100% CLOSED.</li> <li>The brake is mounted inside of the servo motor.</li> </ul>
4	<ul style="list-style-type: none"> <li>The amount of clearance, or free rotation, from a point based in one direction to a point in the opposite direction with torque applied, between the drive connection of the brake to the servo motor shaft.</li> <li>25% of the rated torque of the brake can be applied during the backlash measurement.</li> </ul>
5	<ul style="list-style-type: none"> <li>Maximum Backlash is calculated using worst-case tolerances.</li> <li>Typical Backlash is calculated using statistical tolerances.</li> </ul>
6	Release and response times measured on standalone brakes connected to hard switching power supply.
7	<ul style="list-style-type: none"> <li>Brake release time is fairly consistent regardless of how the brake is switched.</li> <li>This is the time for the brake to release when the power is applied to the brake.</li> </ul>
8	<ul style="list-style-type: none"> <li>Brake response time when the decay circuit within the brake, when the power is removed, is prolonged.</li> <li>This is the time taken for the brake to re-engage when the power is removed if the circuit contains any form of arc suppression over the switching.</li> </ul>
9	<ul style="list-style-type: none"> <li>Removing the brake supply on the DC side gives the fastest possible switching.</li> <li>This is a clean cut in the brake supply at the brake connection.</li> </ul>
10	Current of the brake is calculated from nominal voltage and nominal resistance at 25 °C.
11	Acceleration calculated from maximum acceleration of Kollmorgen AKME servo motor with the brake without external load.
12	Brake is able to perform 50.000.000 reverse cycles with maximum acceleration and backlash up to 0.8°.
13	$B_{10d}$ is the number of operations where 10% of the sample would fail to danger.
14	<ul style="list-style-type: none"> <li>New brake - brake mounted in the servo motor without previous usage.</li> <li>Parameters could be influenced by the number of emergency stops absorbed by brake during lifetime.</li> </ul>
15	<ul style="list-style-type: none"> <li>Response times measured on standalone brakes connected to a Kollmorgen AKD drive. See "Holding Brake Functionality" (→ p. 138).</li> <li><math>B_{10d}</math> and Number of Springs is specific to AKM servo motors with brakes labeled <b>Made in Czech Republic</b>. <ul style="list-style-type: none"> <li>Contact Kollmorgen for detailed specification and all other inquiries.</li> </ul> </li> </ul>
16	Contact Kollmorgen for detailed specification and all other inquiries.
17	<ul style="list-style-type: none"> <li>Response times measured on standalone brakes connected to a Kollmorgen AKD drive. See "Holding Brake Functionality" (→ p. 138).</li> <li>Response time of the brake measured with a diode and a transistor in power supply current.</li> </ul>
18	<ul style="list-style-type: none"> <li>Vertical load application setup requires using the AKD or alternative drive manufacturer's total torque rise time.</li> <li>See "Time Needed to Achieve 90% of Static Torque" (→ p. 137).</li> </ul>

## 12.6 Time Needed to Achieve 90% of Static Torque

This is the minimum time required for the brake to engage and hold vertical loads.

### 12.6.1 Brake Switching Cycle for AKD or AKD2G Drives

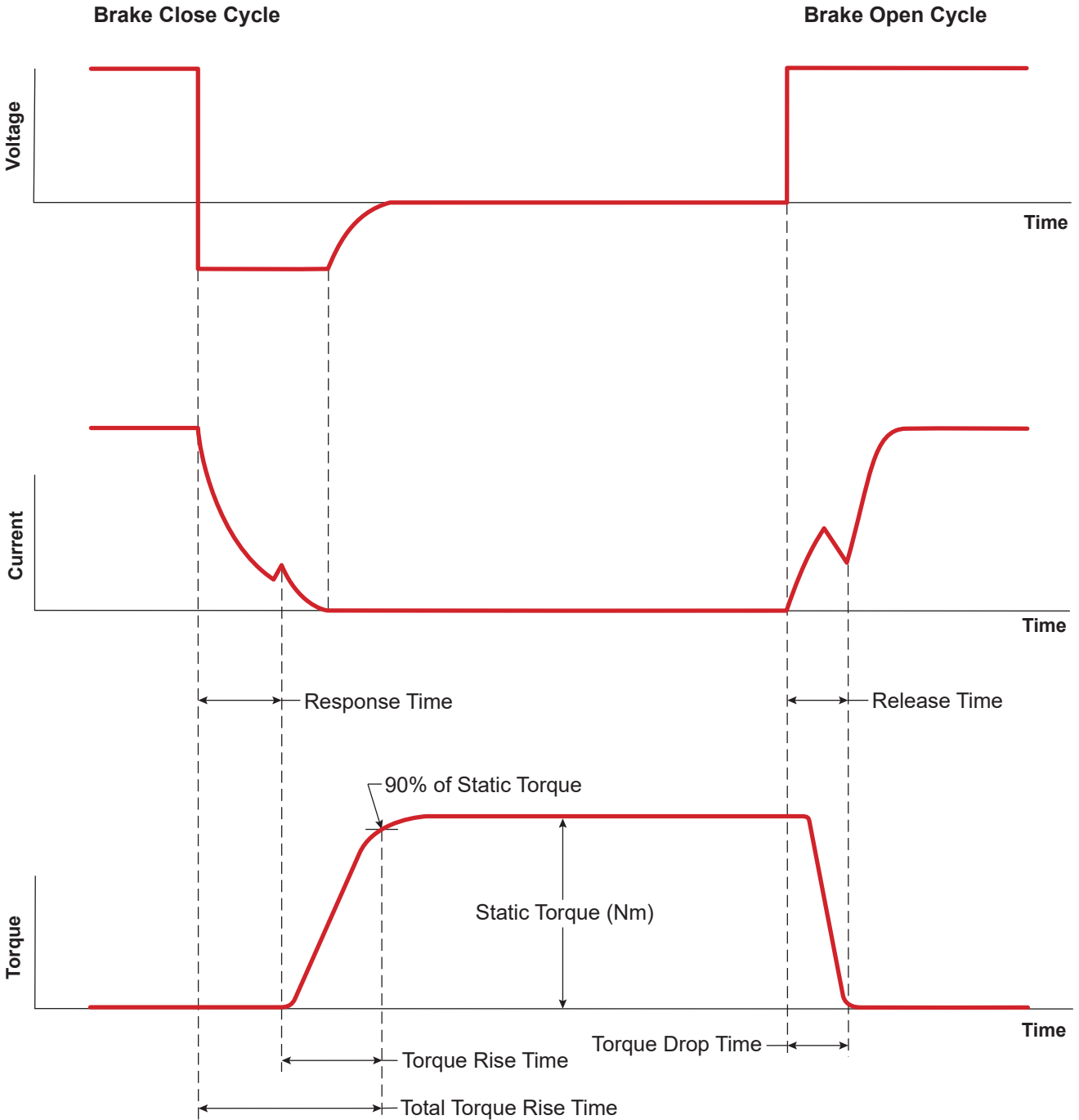

## 12.7 Holding Brake Functionality

The brake function must be enabled through a drive parameter.

- The image shows the timing and functional relationships between the controlled stop signal, speed, and braking force.
  - All values can be adjusted with drive parameters; values in the diagram are default values.
- The parameters shown are specific to Kollmorgen AKD2G drives .
  - See [WorkBench Help - AKD2G](#) for the drive parameter details.
- The drive speed setpoint is internally driven down an adjustable ramp (AXIS#.CS.DEC) to 0 V.
- With default values, the output for the brake is switched on when the speed has reached 5 rpm (AXIS#.ZEROV) for at least 6 ms (AXIS#.ZEROT).
- The rise ( $t_{BRH}[ms]$ ) and fall ( $t_{BRL}[ms]$ ) times of the holding brake built into the servo motor are different for the various types of servo motor.

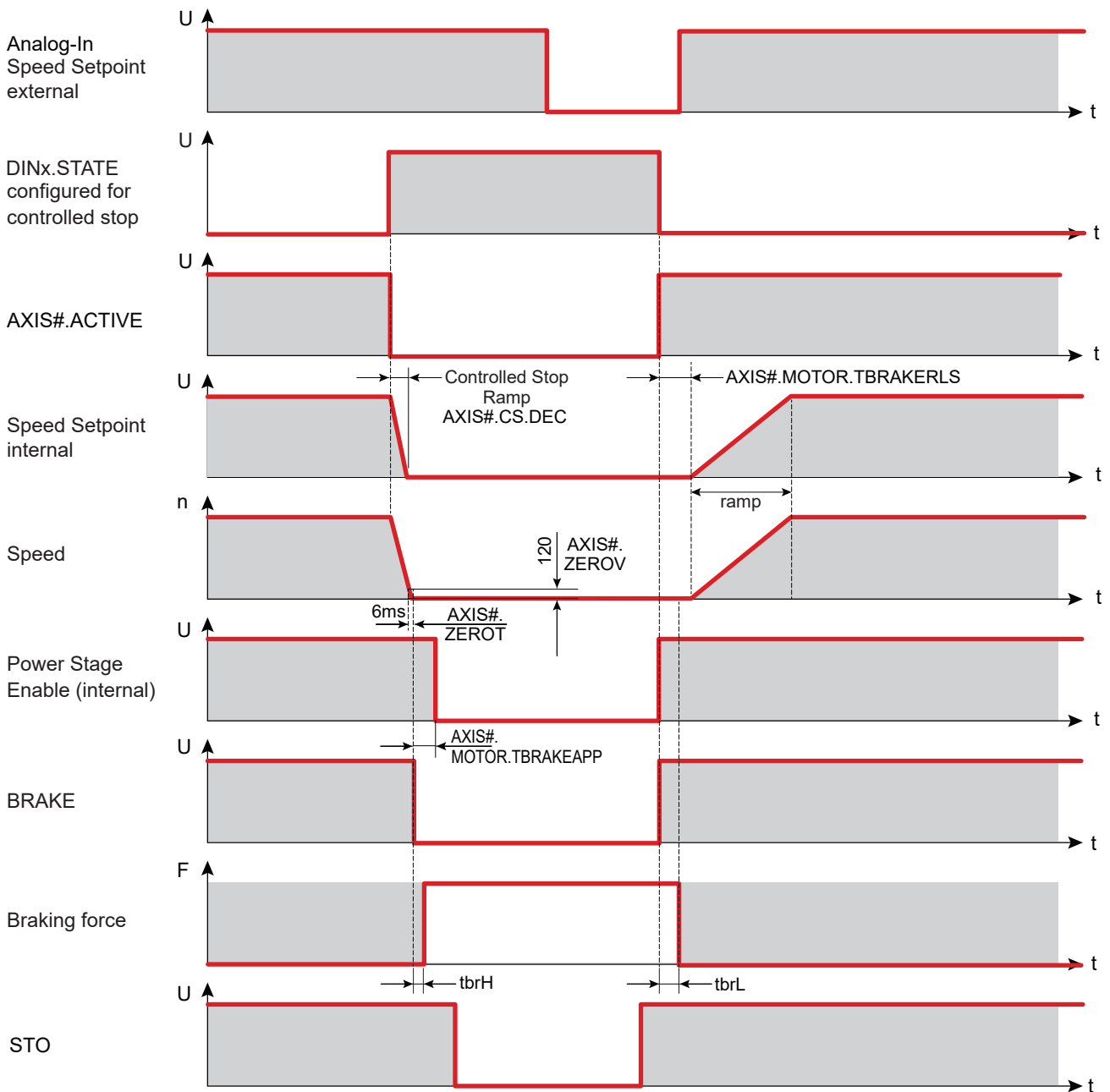

## 12.8 Brake and Servo Motor Terminology

### 12.8.1 Brake Terms

English	中文
Brake data	制动器数据
Electrical power	电源
Engage delay time	启用延迟时间
Holding torque	保持转矩
Moment of inertia	转动惯量
Operating voltage	工作电压
Release delay time	释放延迟时间
Typical backlash	典型齿隙
Weight of the brake	制动器重量

## 12.8.2 Servo Motor Terms

English	中文
Axial load permitted	允许的轴载荷
Data	数据
Derating for feedback, brake, shaft seal	反馈器、制动器、轴封的降额
Electrical data	电气数据
Maximum mains voltage	最大主电源电压
Mechanical data	机械数据
Minimum cross section	最小截面
Peak Current	峰值电流
Peak Torque	峰值转矩
Pole Number	杆号
Radial load permitted at shaft end	轴端允许径向载荷
Rated power	额定功率
Rated speed	额定转速
Rated torque	额定转矩
Reference flange	参考法兰
Rotor moment of inertia	转子转动惯量
Standstill current	堵转电流
Standstill torque	堵转转矩
Static friction torque	静摩擦转矩
Symbol [Unit]	符号 [单位]
Thermal time constant	热时间常数
Torque constant	转矩常数
Voltage constant	电压常数
Weight standard	标准重量
Winding inductance	绕组电感
Winding resistance	绕组电阻

## 13 AKME - L10 Servo Motor Bearing Fatigue

### 13.1 AKME2 to AKME4 - Servo Motor Bearing Fatigue

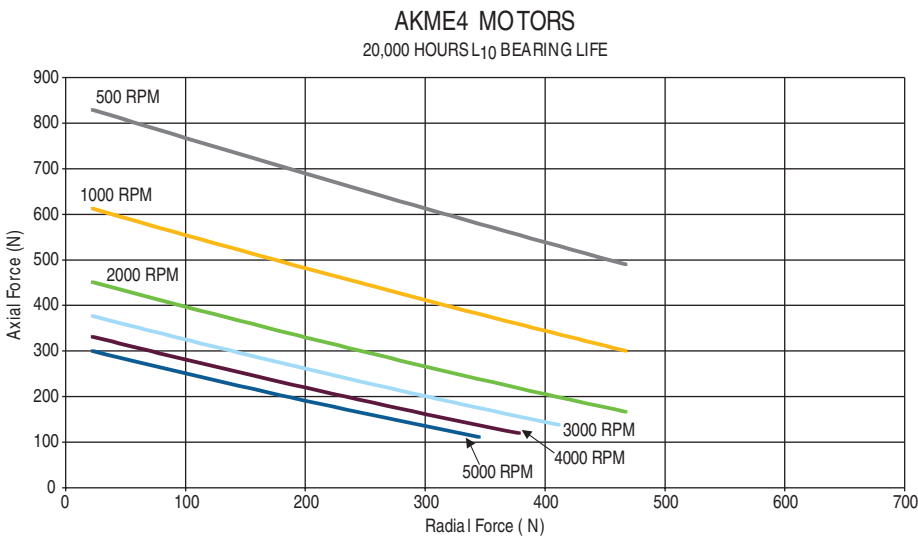
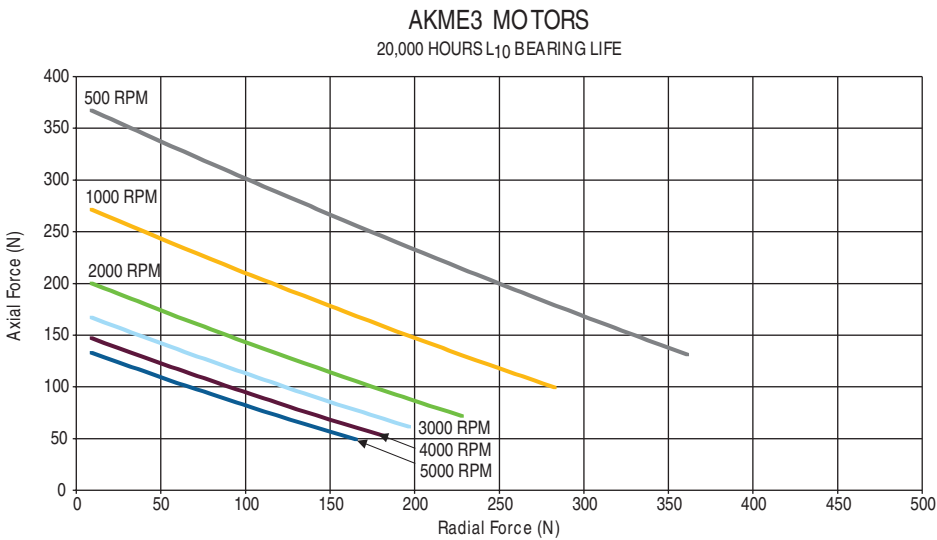
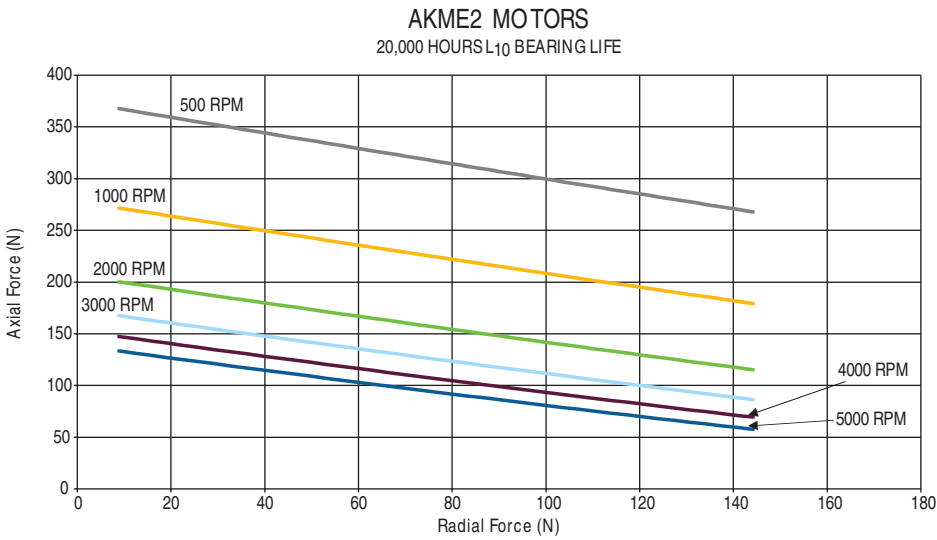

## 13.2 AKME5 to AKME7 - Servo Motor Bearing Fatigue

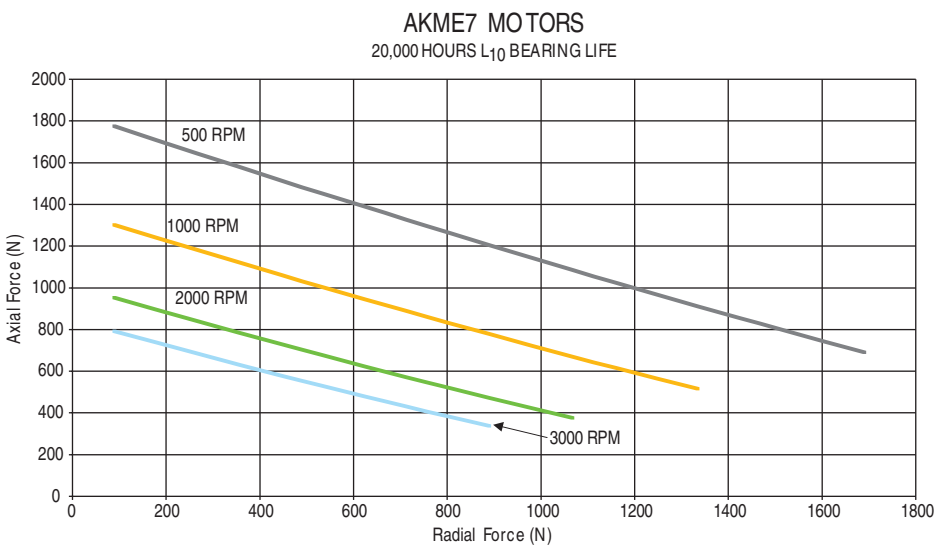
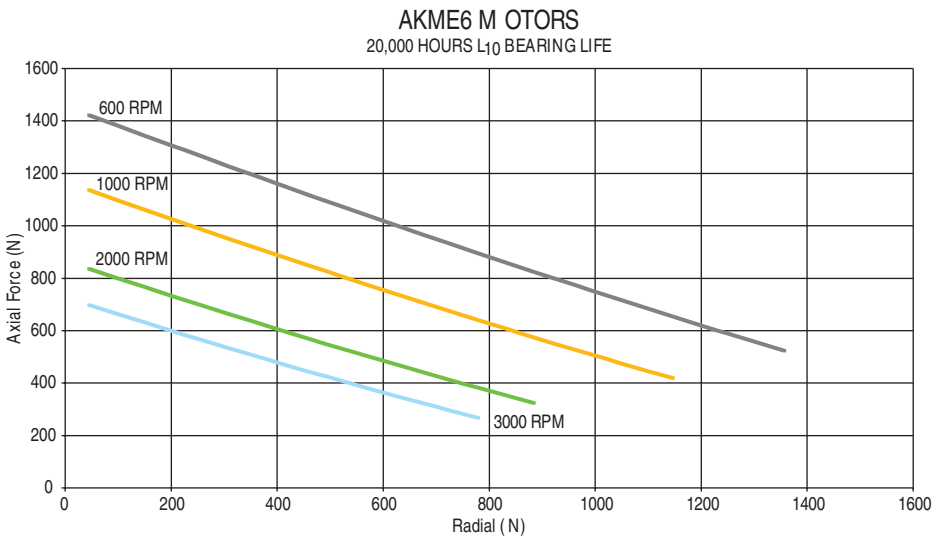
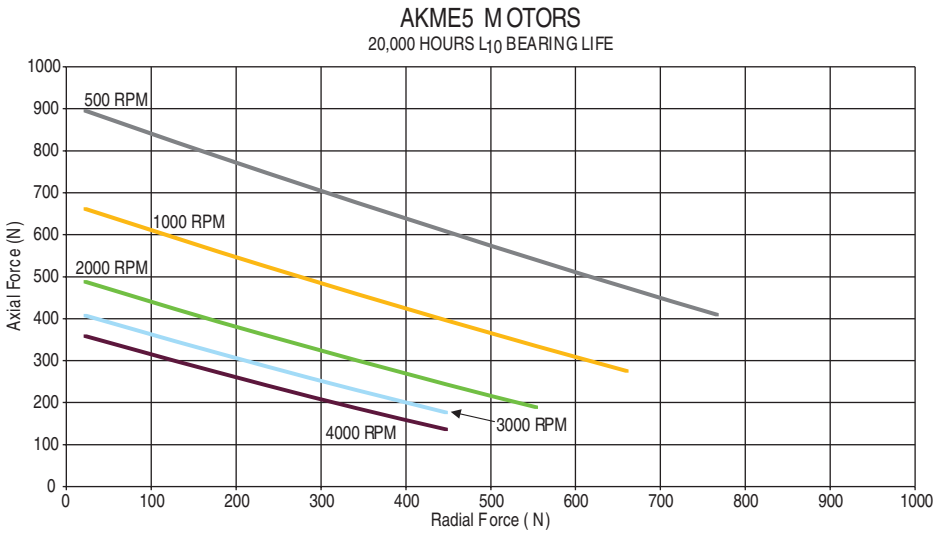

## 14 Delta Between Motor Winding and Thermal Device in 40 °C Ambient

When using a drive other than Kollmorgen AKD, AKD2G, or Kollmorgen Essentials™, the difference (Delta  $\Delta$ ) in temperature between the value reported by the thermal sensor and the actual motor winding temperature must be calculated.

- This is necessary to insure proper operation and protection of the motor.
- The graph shows the delta between the reported device temperature on the x-axis and the motor winding temperature on the y-axis.
  - This should be used to adjust the response of the system for the difference between the thermal sensors reported temperature and the actual motor winding temperature.
  - See "Delta Between Motor Winding and Thermal Device Curve" (→ p. 143).

### 14.1 Examples

- With a thermal device temperature of 60 °C, the winding temperature is 1.8 °C higher (61.8 °C).
- With a thermal device temperature of 126.4 °C, the maximum winding temperature is 8.6 °C higher (135 °C - ATEX Limit).

### 14.2 Delta Between Motor Winding and Thermal Device Curve

Delta Between AKME Motor Winding & Thermal Device in a 40 °C Ambient

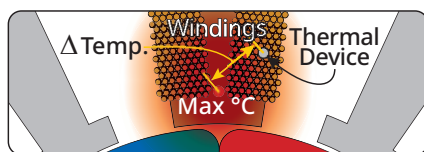
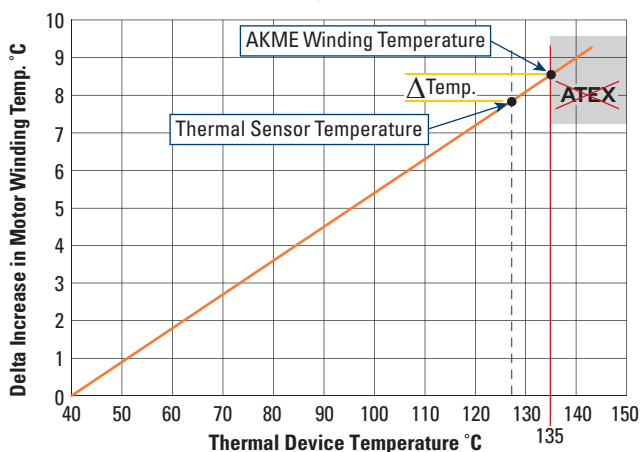

## 15 Approvals

---

15.1 ATEX and IECEx Conformance .....	145
15.2 Conformance with CE .....	145
15.3 Conformance with REACH .....	146
15.4 Conformance with RoHS .....	147

## 15.1 ATEX and IECEx Conformance



	ATEX	IECEx
Marking	 II 3G Ex ec mc IIC T4 Gc II 3D Ex tc IIIC T130°C Dc	Ex ec mc IIC T4 Gc Ex tc IIIC T130°C Dc
Conformance	ATEX 2014/34/EU Directive  EN IEC 60079-0:2018 (Explosive atmospheres - Part 0: Equipment - General requirements) EN IEC 60079-7:2015/A1:2018 (Explosive atmospheres - Part 7: Equipment protection by increased safety 'e') EN 60079-18:2015/A1:2017 (Explosive atmospheres - Part 18: Equipment protection by encapsulation "m") EN IEC 60079-31:2024 (Explosive atmospheres - Part 31: Equipment dust ignition protection by enclosure 't')	IEC 60079-0:2017 (Explosive atmospheres - Part 0: Equipment - General requirements) IEC 60079-7:2015/A1:2017 (Explosive atmospheres - Part 7: Equipment protection by increased safety 'e') IEC 60079-18:2017 (Explosive atmospheres - Part 18: Equipment protection by encapsulation "m") IEC 60079-31:2022 (Explosive atmospheres - Part 31: Equipment dust ignition protection by enclosure 't')

**NOTE**

See "IECEx - Conformity Certificate" (→ p. 148).

## 15.2 Conformance with CE

The servo motors have been tested by an authorized testing laboratory in a defined configuration.

- Any divergence from the configuration and installation described in this documentation means that the user is responsible for carrying out new measurements to ensure conformance with regulatory requirements.

**NOTICE**

**Feedback systems and contacts must not be tested with high voltage.**

- Feedback systems are not suitable for high voltage testing, it is allowed to exclude sensitive electronic components from these tests.
- Feedback systems might be destroyed during a high voltage test.

**NOTE**

CE Declaration of Conformity are on the Kollmorgen website.

Kollmorgen declares the conformity of the AKME product series with these directives:

- CE Directive 2014/30/EU, Electromagnetic compatibility
- CE Directive 2014/35/EU, Low voltage

### 15.3 Conformance with REACH

EU Regulation no. 1907/2006 deals with the registration, evaluation, authorization and restriction of chemical substances 1 (abbreviated to "REACH").

The AKME servo motors do not contain substances which meet the conditions of restriction set in Annex XVII.

## 15.4 Conformance with RoHS

In accordance with the directive 2011/65/EU of the European Parliament and of the Council of 8 June 2011 concerning the Restriction of the Use of Certain Hazardous Substances in Electrical and Electronic Equipment, including Commission Delegated Directive (EU) 2015/863.

The AKME servo motors RoHS Compliance Status: Compliant with exemption.

Cadmium (Cd), Lead (Pb), Mercury (Hg), Hexavalent chromium (Cr6+), Polybrominated biphenyls (PBB), Polybrominated diphenyl ethers (PBDE), Bis(2-ethylhexyl) phthalate (DEHP), Butyl benzyl phthalate (BBP), Dibutyl phthalate (DBP), Diisobutyl phthalate (DIBP)

## 15.5 IECEx - Conformity Certificate

---

15.5.1 IECEx - Conformity Certificate - Page 1 .....	149
15.5.2 IECEx - Conformity Certificate - Page 2 .....	150
15.5.3 IECEx - Conformity Certificate - Page 3 .....	151
15.5.4 IECEx - Conformity Certificate - Page 4 .....	152

## 15.5.1 IECEx - Conformity Certificate - Page 1



# IECEx Certificate of Conformity

## INTERNATIONAL ELECTROTECHNICAL COMMISSION IEC Certification System for Explosive Atmospheres

for rules and details of the IECEx Scheme visit [www.iecex.com](http://www.iecex.com)

Certificate No.:	<b>IECEx TPS 25.0065X</b>	Page 1 of 4	<a href="#">Certificate history:</a>
Status:	<b>Current</b>	Issue No: 0	
Date of Issue:	2026-01-19		
Applicant:	<b>A&amp;S Industry Technology (Tianjin) Co., Ltd.</b> No. D9-1/D9-2, Saida International Industrial City Xiqing Economic & Technological District Tianjin 300385 <b>China</b>		
Equipment:	<b>Ex PM SERVO MOTOR, type: AKME series</b>		
Optional accessory:			
Type of Protection:	<b>Increased safety "ec", Encapsulation "mc", Dust ignition protection by enclosures "tc"</b>		
Marking:	Ex ec mc IIC T4 Gc Ex tc IIIC T130°C Dc		

Approved for issue on behalf of the IECEx  
Certification Body:

**Xia Jiayan**

Position:

**Technical Certifier**

Signature:  
(for printed version)

Date:  
(for printed version)

2026-01-19

1. This certificate and schedule may only be reproduced in full.
2. This certificate is not transferable and remains the property of the issuing body.
3. The Status and authenticity of this certificate may be verified by visiting [www.iecex.com](http://www.iecex.com) or use of this QR Code.



Certificate issued by:

**TÜV SÜD Product Service GmbH**  
Ridlerstr. 65  
D-80339 Munich  
Germany



## 15.5.2 IECEx - Conformity Certificate - Page 2



# IECEX Certificate of Conformity

Certificate No.: **IECEX TPS 25.0065X** Page 2 of 4  
 Date of issue: 2026-01-19 Issue No: 0

Manufacturer: **A&S Industry Technology (Tianjin) Co., Ltd.**  
 No. D9-1/D9-2, Saida International Industrial City  
 Xiqing Economic & Technological District  
 Tianjin 300385  
**China**

Manufacturing locations: **A&S Industry Technology (Tianjin) Co., Ltd.**  
 No. D9-1/D9-2, Saida International Industrial City  
 Xiqing Economic & Technological District  
 Tianjin 300385  
**China**

This certificate is issued as verification that a sample(s), representative of production, was assessed and tested and found to comply with the IEC Standard list below and that the manufacturer's quality system, relating to the Ex products covered by this certificate, was assessed and found to comply with the IECEx Quality system requirements. This certificate is granted subject to the conditions as set out in IECEx Scheme Rules, IECEx 02 and Operational Documents as amended

### STANDARDS :

The equipment and any acceptable variations to it specified in the schedule of this certificate and the identified documents, was found to comply with the following standards

- [IEC 60079-0:2017](#) Explosive atmospheres - Part 0: Equipment - General requirements  
Edition:7.0
- [IEC 60079-18:2017](#) Explosive atmospheres - Part 18: Protection by encapsulation "m"  
Edition:4.1
- [IEC 60079-31:2022](#) Explosive atmospheres – Part 31: Equipment dust ignition protection by enclosure "t"  
Edition:3.0
- [IEC 60079-7:2017](#) Explosive atmospheres - Part 7: Equipment protection by increased safety "e"  
Edition:5.1

This Certificate **does not** indicate compliance with safety and performance requirements other than those expressly included in the Standards listed above.

### TEST & ASSESSMENT REPORTS:

A sample(s) of the equipment listed has successfully met the examination and test requirements as recorded in:

Test Report:

[DE/TPS/ExTR25.0068/00](#)

Quality Assessment Report:

[DE/TPS/QAR24.0002/01](#)

## 15.5.3 IECEx - Conformity Certificate - Page 3



# IECEx Certificate of Conformity

Certificate No.: **IECEx TPS 25.0065X**

Page 3 of 4

Date of issue: 2026-01-19

Issue No: 0

**EQUIPMENT:**

Equipment and systems covered by this Certificate are as follows:

The AKME series servo motors are intended to be used in Zone 2 and Zone 22. The protection types of the equipment are increased safety "ec", encapsulation "mc", dust ignition protection by enclosures "tc"

Each servo motor mainly consists of a rotor, stator, bearing, encoder, and connector. The stator has a protection type of encapsulation "mc". The enclosure has a protection type of increased safety "ec" and dust ignition protection by enclosures "tc"

The different series of servo motors have similar designs but vary in size, volume, and electrical parameters, type of connector and with or without a brake.

For the AKME1 series, install the clamping plate to secure the connector using hexagon fasteners at the connection to prevent the risk of disconnection. The cable shall be attached to the motor.

The servo motor is made of aluminum alloy and has an ingress protection IP64 according to IEC 60079-0.

The synchronous servo motor operates in drive systems together with Kollmorgen servo drives under specified speed and/or torque control. All manufacturer instructions regarding frequency or speed range, and torque limitations must be followed.

**SPECIFIC CONDITIONS OF USE: YES as shown below:**

1. The servo motor must be used with the drive which specified as manufacturer's user manual and complies with the motor electrical specifications and operating characteristics. Frequency converter must be chosen according to the parameters specified in this certificate. The maximum prospective short-circuit current of the driver is 300A.
2. The performance data of the explosion proof motor must be used in according to the technical data.
3. The connectors are tested with the servo motor to ensure ingress protection of IEC 60079-0 completely.  
For AKME1 series, the bonding conductor connection on the clamping plate shall provide effective connection to the metal enclosure. The external earthing connection shall be connected to the grounding system of the final end-installation according to the user manual.  
For AKME2 series, AKME3 series, AKME4 series, AKME5 series, AKME6 series, AKME7 series, the mating connectors and cable must be chosen according to the type specified in user manual.
4. The brakes are intended to be used only as parking device.
5. Each motor shall be equipped with a thermal protector connected to the motor control circuit in such a manner as to disconnect the source of supply to prevent exceeding the specified temperature class.
6. For installation in Zone 2 hazardous area, transient protection shall be provided that is set at a level not exceeding 140 % of the peak rated voltage value at the supply terminals to the equipment (see Annex H.5 of IEC 60079-7).
7. For installation in Zone 2 hazardous area, the equipment is intended to be installed in environments with a pollution level that shall be limited to pollution degree 2 or better, as defined in IEC 60664-1 (see Annex H.3 of IEC 60079-7).

## 15.5.4 IECEx - Conformity Certificate - Page 4



# IECEx Certificate of Conformity

Certificate No.: **IECEx TPS 25.0065X**

Page 4 of 4

Date of issue: 2026-01-19

Issue No: 0

### Equipment (continued):

Rating:

Max. rated input voltage: 400 V AC

Max. rated DC bus voltage: 560 V DC

Modulation: PWM

Duty type: S1

Degree of protection: IP 64

Ambient temperature:  $+5\text{ °C} \leq T_a \leq +40\text{ °C}$

AKME1 Series, Max. Rated power: 0.21 kW

AKME2 Series, Max. Rated power: 0.62 kW

AKME3 Series, Max. Rated power: 1.15 kW

AKME4 Series, Max. Rated power: 1.52 kW

AKME5 Series, Max. Rated power: 3.59 kW

AKME6 Series, Max. Rated power: 5.74 kW

AKME7 Series, Max. Rated power: 7.64 kW

Details see Annex of IECEx Certificate of Conformity

### Annex:

[Annex to CoC IECEx TPS 25.0065X.pdf](#)

## 15.6 IECEx - Conformity Certificate Annex

---

15.6.1 Annex to CoC IECEx TPS 25.0065X - Page 1 .....	154
15.6.2 Annex to CoC IECEx TPS 25.0065X - Page 2 .....	155
15.6.3 Annex to CoC IECEx TPS 25.0065X - Page 3 .....	156
15.6.4 Annex to CoC IECEx TPS 25.0065X - Page 4 .....	157
15.6.5 Annex to CoC IECEx TPS 25.0065X - Page 5 .....	158
15.6.6 Annex to CoC IECEx TPS 25.0065X - Page 6 .....	159
15.6.7 Annex to CoC IECEx TPS 25.0065X - Page 7 .....	160
15.6.8 Annex to CoC IECEx TPS 25.0065X - Page 8 .....	161
15.6.9 Annex to CoC IECEx TPS 25.0065X - Page 9 .....	162
15.6.10 Annex to CoC IECEx TPS 25.0065X - Page 10 .....	163
15.6.11 Annex to CoC IECEx TPS 25.0065X - Page 11 .....	164
15.6.12 Annex to CoC IECEx TPS 25.0065X - Page 12 .....	165

15.6.1 Annex to CoC IECEx TPS 25.0065X - Page 1



IECEx Certificate of Conformity



Product Service

**Annex to certificate:** IECEx TPS 25.0065X Issue No: 0  
**Applicant:** A&S Industry Technology (Tianjin) Co., Ltd.  
 No. D9-1/D9-2, Saida International Industrial City  
 Xiqing Economic & Technological District 300385 Tianjin, China  
**Apparatus:** Ex PM SERVOMOTOR  
**Type(s):** AKME series

Model designation:

AKME 5 3 G - A C 4 2 R- XX  
 1 2 3 4 5 6 7 8 9 10

1	-	AKME Explosion-proof series
2	-	Flange Size: 1 40mm 2 58mm 3 70mm 4 84mm 5 108mm 6 138mm 7 188mm
3	-	Rotor Length 1 1 Stack 2 2 Stack 3 3 Stack 4 4 Stack 5 5 Stack
4	-	Winding Type: B to Q
5	-	Flange interface: A to Z Design features without relevance for Ex protection.
6	-	Shaft C Closed Keyway K Open keyway N Smooth shaft S Special
7	-	Connectors: 4 Dual 90° M23 connectors (AKME2-7, except AKME72Q, AKME73Q, AKME74Q) 9 1 Hybrid M23 connector (AKME2-6) W 90° M40 power and M23 feedback connector (AKME72Q, AKME73Q, AKME74Q) Z Y-TEC connector with x meter cable clamp (AKME1)
8	-	Brake 2 24 V holding brake N Without brake
9	-	Feedback Type: A to Z or 0 to 9 or "-" Design features without relevance for Ex protection.
10	-	Customization: Design features without relevance for Ex protection. A to Z or 0 to 9 or "-"

Model difference:

The connector of AKME1 with clamping unit is tested integrated with the servo motor. The cable shall be attached with the motor.  
 For AKME2 series, AKME3 series, AKME4 series, AKME5 series, AKME6 series, AKME7 series, the connector employing parallel threads with an additional seal. The installation manual for the cable must be followed.  
 They are similar in design but vary in size, electrical parameters with or without a brake.

Title: Annex to CoC  
 IECEx TPS 25.0065X  
 Issue No: 0  
 Date of Issue: 2026-01-19  
 Page 1 of 12



TUV SUD Product Service GmbH  
 Certification Body for Products  
 Riderstraße 65  
 D-80339 Munich  
 Germany

15.6.2 Annex to CoC IECEx TPS 25.0065X - Page 2



**IECEx Certificate of Conformity**



Product Service

**Annex to certificate:** IECEx TPS 25.0065X Issue No: 0  
**Applicant:** A&S Industry Technology (Tianjin) Co., Ltd.  
 No. D9-1/D9-2, Saida International Industrial City  
 Xiqing Economic & Technological District 300385 Tianjin, China  
**Apparatus:** Ex PM SERVOMOTOR  
**Type(s):** AKME series

Other technical differences, see table 1 of the Annex.  
 The connectors used on each series motor and the matching cable and mating connector, see table 2 of Annex.

Technical data:

Table 1:

Model	Winding	Voltage	Rated Torque (Nm)	Rated Speed (rpm)	Rated Power (kW)
AKME11	B	120 V AC	0.16	4000	0.07
AKME11	C	120 V AC	0.15	6000	0.09
AKME11	E	75 V DC	0.15	6000	0.09
AKME11	F	48 V DC	0.15	5000	0.08
AKME11	F	75 V DC	0.14	6000	0.09
AKME12	C	120 V AC	0.304	4000	0.13
AKME12	E	48 V DC	0.28	1500	0.04
AKME12	E	75 V DC	0.28	3000	0.1
AKME12	E	120 V AC	0.26	6000	0.16
AKME13	C	120 V AC	0.407	3000	0.13
AKME13	D	75 V DC	0.401	2000	0.08
AKME13	D	120 V AC	0.34	6000	0.21
AKME21	C	120 V AC	0.4	2500	0.1
AKME21	C	240 V AC	0.36	5000	0.19
AKME21	E	75 V DC	0.41	2000	0.09
AKME21	E	120 V AC	0.38	5000	0.2
AKME21	G	75 V DC	0.4	4000	0.17
AKME21	J	48 V DC	0.38	4500	0.16
AKME21	J	75 V DC	0.32	5000	0.17
AKME22	C	120 V AC	0.76	1000	0.08

Title: Annex to CoC  
 IECEx TPS 25.0065X  
 Issue No: 0  
 Date of Issue: 2026-01-19  
 Page 2 of 12



TÜV SÜD Product Service GmbH  
 Certification Body for Products  
 Ridlerstraße 65  
 D-80339 Munich  
 Germany

### 15.6.3 Annex to CoC IECEx TPS 25.0065X - Page 3



## IECEx Certificate of Conformity



Product Service

**Annex to certificate:**  
**Applicant:**

IECEx TPS 25.0065X Issue No: 0  
A&S Industry Technology (Tianjin) Co., Ltd.  
No. D9-1/D9-2, Saida International Industrial City  
Xiqing Economic & Technological District 300385 Tianjin, China  
Ex PM SERVOMOTOR  
AKME series

**Apparatus:**  
**Type(s):**

Model	Winding	Voltage	Rated Torque (Nm)	Rated Speed (rpm)	Rated Power (kW)
AKME22	C	240 V AC	0.71	3500	0.26
AKME22	C	400 V AC	0.68	5000	0.36
AKME22	E	75 V DC	0.78	1000	0.08
AKME22	E	120 V AC	0.73	3500	0.27
AKME22	E	240 V AC	0.7	5000	0.37
AKME22	G	75 V DC	0.76	2500	0.2
AKME22	G	120 V AC	0.71	5000	0.37
AKME22	H	48 V DC	0.79	1500	0.12
AKME22	H	75 V DC	0.76	3000	0.24
AKME22	H	120 V AC	0.71	5000	0.37
AKME23	C	120 V AC	1.04	1000	0.11
AKME23	C	240 V AC	1.00	2500	0.26
AKME23	C	400 V AC	0.93	5000	0.49
AKME23	D	120 V AC	1.04	1500	0.16
AKME23	D	240 V AC	0.95	5000	0.5
AKME23	D	400 V AC	0.95	5000	0.5
AKME23	E	120 V AC	1.03	2500	0.27
AKME23	E	240 V AC	0.95	5000	0.5
AKME23	F	75 V DC	1.07	1500	0.17
AKME23	F	120 V AC	0.98	4500	0.46
AKME23	F	240 V AC	0.97	5000	0.51
AKME24	C	240 V AC	1.24	2000	0.26
AKME24	C	400 V AC	1.16	4500	0.55
AKME24	D	120 V AC	1.28	1500	0.2
AKME24	D	240 V AC	1.2	4000	0.5

Title: Annex to CoC  
IECEx TPS 25.0065X  
Issue No: 0  
Date of Issue: 2026-01-19  
Page 3 of 12



TÜV SÜD Product Service GmbH  
Certification Body for Products  
Ridlerstraße 65  
D-80339 Munich  
Germany

15.6.4 Annex to CoC IECEX TPS 25.0065X - Page 4



**IECEX Certificate of Conformity**



Product Service

**Annex to certificate:**

**Applicant:**

**Apparatus:**

**Type(s):**

IECEX TPS 25.0065X Issue No: 0  
 A&S Industry Technology (Tianjin) Co., Ltd.  
 No. D9-1/D9-2, Saida International Industrial City  
 Xiqing Economic & Technological District 300385 Tianjin, China  
 Ex PM SERVOMOTOR  
 AKME series

Model	Winding	Voltage	Rated Torque (Nm)	Rated Speed (rpm)	Rated Power (kW)
AKME24	D	400 V AC	1.17	5000	0.61
AKME24	E	120 V AC	1.26	2000	0.26
AKME24	E	240 V AC	1.17	5000	0.61
AKME24	F	75 V DC	1.31	1000	0.14
AKME24	F	120 V AC	1.24	3000	0.39
AKME24	F	240 V AC	1.18	5000	0.62
AKME31	C	240 V AC	1.05	2500	0.27
AKME31	C	400 V AC	0.92	5000	0.48
AKME31	E	75 V DC	1.12	750	0.09
AKME31	E	120 V AC	1.09	2500	0.29
AKME31	E	240 V AC	0.96	5000	0.5
AKME31	H	75 V DC	1.13	2000	0.24
AKME31	H	120 V AC	1.01	5000	0.53
AKME31	K	48 V DC	1.15	2000	0.24
AKME31	K	75 V DC	1.11	3500	0.41
AKME31	K	120 V AC	1.01	5000	0.53
AKME32	C	240 V AC	1.85	1500	0.29
AKME32	C	400 V AC	1.76	3000	0.55
AKME32	D	120 V AC	1.9	1000	0.2
AKME32	D	240 V AC	1.83	2500	0.48
AKME32	D	400 V AC	1.61	5000	0.84
AKME32	E	120 V AC	1.92	1000	0.2
AKME32	E	240 V AC	1.81	3000	0.57
AKME32	E	400 V AC	1.63	5000	0.85
AKME32	H	75 V DC	1.96	1200	0.25

Title: Annex to CoC  
 IECEX TPS 25.0065X  
 Issue No: 0  
 Date of Issue: 2026-01-19  
 Page 4 of 12



TÜV SÜD Product Service GmbH  
 Certification Body for Products  
 Ridlerstraße 65  
 D-80339 Munich  
 Germany

15.6.5 Annex to CoC IECEx TPS 25.0065X - Page 5



IECEx Certificate of Conformity



Product Service

**Annex to certificate:** IECEx TPS 25.0065X Issue No: 0  
**Applicant:** A&S Industry Technology (Tianjin) Co., Ltd.  
 No. D9-1/D9-2, Saida International Industrial City  
 Xiqing Economic & Technological District 300385 Tianjin, China  
**Apparatus:** Ex PM SERVOMOTOR  
**Type(s):** AKME series

Model	Winding	Voltage	Rated Torque (Nm)	Rated Speed (rpm)	Rated Power (kW)
AKME32	H	120 V AC	1.87	3000	0.59
AKME32	H	240 V AC	1.67	5000	0.87
AKME33	C	240 V AC	2.55	1000	0.27
AKME33	C	400 V AC	2.45	2000	0.51
AKME33	E	240 V AC	2.52	2000	0.53
AKME33	E	400 V AC	2.22	4500	1.05
AKME33	H	75 V DC	2.69	800	0.23
AKME33	H	120 V AC	2.53	2500	0.66
AKME33	H	240 V AC	2.2	5000	1.15
AKME41	C	240 V AC	1.76	1200	0.22
AKME41	C	400 V AC	1.64	3000	0.52
AKME41	E	120 V AC	1.82	1200	0.23
AKME41	E	240 V AC	1.7	3000	0.53
AKME41	E	400 V AC	1.55	5000	0.81
AKME41	H	75 V DC	1.87	1000	0.2
AKME41	H	120 V AC	1.74	3000	0.55
AKME41	H	240 V AC	1.59	5000	0.83
AKME42	C	400 V AC	2.94	1500	0.46
AKME42	E	240 V AC	2.94	1800	0.55
AKME42	E	400 V AC	2.65	3500	0.97
AKME42	G	240 V AC	2.73	3500	1.0
AKME42	G	400 V AC	2.41	5000	1.26
AKME42	H	120 V AC	3.05	2000	0.64
AKME42	J	120 V AC	2.88	3000	0.9
AKME42	J	240 V AC	2.46	5000	1.29

Title: Annex to CoC  
 IECEx TPS 25.0065X  
 Issue No: 0  
 Date of Issue: 2026-01-19  
 Page 5 of 12



TÜV SÜD Product Service GmbH  
 Certification Body for Products  
 Ridlerstraße 65  
 D-80339 Munich  
 Germany

15.6.6 Annex to CoC IECEx TPS 25.0065X - Page 6



**IECEx Certificate of Conformity**



Product Service

**Annex to certificate:** IECEx TPS 25.0065X Issue No: 0  
**Applicant:** A&S Industry Technology (Tianjin) Co., Ltd.  
 No. D9-1/D9-2, Saida International Industrial City  
 Xiqing Economic & Technological District 300385 Tianjin, China  
**Apparatus:** Ex PM SERVOMOTOR  
**Type(s):** AKME series

Model	Winding	Voltage	Rated Torque (Nm)	Rated Speed (rpm)	Rated Power (kW)
AKME43	E	240 V AC	4.08	1500	0.64
AKME43	E	400 V AC	3.74	2500	0.98
AKME43	G	240 V AC	3.8	2500	0.99
AKME43	G	400 V AC	2.76	5000	1.45
AKME43	H	120 V AC	4.21	1200	0.53
AKME43	H	240 V AC	3.66	3000	1.15
AKME43	H	400 V AC	2.77	5000	1.45
AKME43	K	120 V AC	3.89	2500	1.02
AKME43	K	240 V AC	2.82	5000	1.48
AKME43	L	120 V AC	3.59	3000	1.13
AKME43	L	240 V AC	2.72	5000	1.42
AKME44	E	240 V AC	5.02	1200	0.63
AKME44	E	400 V AC	4.61	2000	0.97
AKME44	G	240 V AC	4.7	2000	0.98
AKME44	G	400 V AC	3.5	5000	1.47
AKME44	H	120 V AC	5.23	1000	0.55
AKME44	H	240 V AC	4.43	2500	1.16
AKME44	H	400 V AC	2.85	4500	1.49
AKME44	J	240 V AC	3.55	4000	1.49
AKME44	J	400 V AC	2.91	5000	1.52
AKME44	K	120 V AC	4.68	2000	0.98
AKME44	K	240 V AC	2.85	5000	1.49
AKME51	E	240 V AC	3.91	1200	0.49
AKME51	E	400 V AC	3.73	2500	0.98
AKME51	G	240 V AC	3.78	2500	0.99

Title: Annex to CoC  
 IECEx TPS 25.0065X  
 Issue No: 0  
 Date of Issue: 2026-01-19  
 Page 6 of 12



TÜV SÜD Product Service GmbH  
 Certification Body for Products  
 Ridlerstraße 65  
 D-80339 Munich  
 Germany

### 15.6.7 Annex to CoC IECEX TPS 25.0065X - Page 7



## IECEX Certificate of Conformity



Product Service

**Annex to certificate:**  
**Applicant:**

IECEX TPS 25.0065X Issue No: 0  
A&S Industry Technology (Tianjin) Co., Ltd.  
No. D9-1/D9-2, Saida International Industrial City  
Xiqing Economic & Technological District 300385 Tianjin, China  
Ex PM SERVOMOTOR  
AKME series

**Apparatus:**  
**Type(s):**

Model	Winding	Voltage	Rated Torque (Nm)	Rated Speed (rpm)	Rated Power (kW)
AKME51	G	400 V AC	2.28	5000	1.19
AKME51	H	120 V AC	4.02	1200	0.51
AKME51	H	240 V AC	3.61	3000	1.13
AKME51	H	400 V AC	2.3	5000	1.2
AKME51	K	120 V AC	3.89	2500	1.02
AKME51	K	240 V AC	2.35	5000	1.23
AKME51	L	120 V AC	3.69	3000	1.16
AKME51	L	240 V AC	2.35	5000	1.23
AKME52	E	400 V AC	7.27	1500	1.14
AKME52	G	240 V AC	7.37	1500	1.16
AKME52	G	400 V AC	6.71	2500	1.76
AKME52	H	240 V AC	7.59	1800	1.43
AKME52	H	400 V AC	5.87	3500	2.15
AKME52	K	240 V AC	6.44	3000	2.02
AKME52	K	400 V AC	4.03	5000	2.11
AKME52	L	120 V AC	7.59	1500	1.19
AKME52	L	240 V AC	6.01	3500	2.2
AKME52	L	400 V AC	4.05	5000	2.12
AKME52	M	240 V AC	4.73	4500	2.23
AKME53	G	240 V AC	10.28	1000	1.08
AKME53	G	400 V AC	9.42	2000	1.97
AKME53	H	240 V AC	10.08	1500	1.58
AKME53	H	400 V AC	8.37	3000	2.63
AKME53	K	240 V AC	9.63	2000	2.02
AKME53	K	400 V AC	7.1	4000	2.97

Title: Annex to CoC  
IECEX TPS 25.0065X  
Issue No: 0  
Date of Issue: 2026-01-19  
Page 7 of 12



TÜV SÜD Product Service GmbH  
Certification Body for Products  
Ridlerstraße 65  
D-80339 Munich  
Germany

15.6.8 Annex to CoC IECEx TPS 25.0065X - Page 8



**IECEx Certificate of Conformity**



Product Service

**Annex to certificate:**  
**Applicant:**

IECEx TPS 25.0065X Issue No: 0  
A&S Industry Technology (Tianjin) Co., Ltd.  
No. D9-1/D9-2, Saida International Industrial City  
Xiqing Economic & Technological District 300385 Tianjin, China  
Ex PM SERVOMOTOR  
AKME series

**Apparatus:**  
**Type(s):**

Model	Winding	Voltage	Rated Torque (Nm)	Rated Speed (rpm)	Rated Power (kW)
AKME53	L	120 V AC	10.41	1200	1.31
AKME53	L	240 V AC	8.44	3000	2.65
AKME53	L	400 V AC	5.32	5000	2.79
AKME53	M	240 V AC	8.26	3000	2.59
AKME53	P	240 V AC	5.21	5000	2.73
AKME53	Q	120 V AC	9.15	2500	2.4
AKME53	Q	240 V AC	5.3	5000	2.78
AKME54	G	400 V AC	12.42	1500	1.95
AKME54	H	240 V AC	12.93	1000	1.35
AKME54	H	400 V AC	12.08	1800	2.28
AKME54	K	240 V AC	12.39	1800	2.34
AKME54	K	400 V AC	9.53	3500	3.49
AKME54	L	240 V AC	10.96	2500	2.87
AKME54	L	400 V AC	7.41	4500	3.49
AKME54	N	240 V AC	9.26	3500	3.39
AKME54	P	240 V AC	8.58	4000	3.59
AKME62	G	400 V AC	9.83	1800	1.85
AKME62	H	240 V AC	10.65	1000	1.12
AKME62	H	400 V AC	9.65	2000	2.02
AKME62	K	240 V AC	9.82	2000	2.06
AKME62	K	400 V AC	8.37	3500	3.07
AKME62	L	240 V AC	9.43	2500	2.47
AKME62	L	400 V AC	6.7	5000	3.51
AKME62	M	240 V AC	8.95	3000	2.81
AKME62	M	400 V AC	6.73	5000	3.52

Title: Annex to CoC  
IECEx TPS 25.0065X  
Issue No: 0  
Date of Issue: 2026-01-19  
Page 8 of 12



TÜV SÜD Product Service GmbH  
Certification Body for Products  
Ridlerstraße 65  
D-80339 Munich  
Germany

### 15.6.9 Annex to CoC IECEx TPS 25.0065X - Page 9



## IECEx Certificate of Conformity



Product Service

**Annex to certificate:**  
**Applicant:**

IECEx TPS 25.0065X Issue No: 0  
A&S Industry Technology (Tianjin) Co., Ltd.  
No. D9-1/D9-2, Saida International Industrial City  
Xiqing Economic & Technological District 300385 Tianjin, China

**Apparatus:**  
**Type(s):**

Ex PM SERVOMOTOR  
AKME series

Model	Winding	Voltage	Rated Torque (Nm)	Rated Speed (rpm)	Rated Power (kW)
AKME62	P	240 V AC	7.42	4500	3.5
AKME62	Q	240 V AC	6.58	5000	3.45
AKME63	G	400 V AC	14.38	1200	1.81
AKME63	H	400 V AC	14	1500	2.2
AKME63	K	240 V AC	14.18	1500	2.23
AKME63	K	400 V AC	12.11	3000	3.8
AKME63	L	240 V AC	13.85	1500	2.61
AKME63	L	400 V AC	12.14	3000	3.81
AKME63	M	240 V AC	13.65	2000	2.86
AKME63	M	400 V AC	10.48	4000	4.39
AKME63	N	240 V AC	12.27	3000	3.85
AKME63	N	400 V AC	8.62	5000	4.51
AKME63	Q	240 V AC	11.1	3500	4.07
AKME64	K	240 V AC	18.01	1200	2.26
AKME64	K	400 V AC	16.41	2000	3.44
AKME64	L	240 V AC	17.68	1500	2.78
AKME64	L	400 V AC	14.75	3000	4.63
AKME64	P	240 V AC	15.24	2500	3.99
AKME64	P	400 V AC	10.88	4500	5.13
AKME64	Q	240 V AC	14.45	3000	4.54
AKME64	Q	400 V AC	9.47	5000	4.96
AKME65	K	240 V AC	21.98	1000	2.3
AKME65	K	400 V AC	19.3	2000	4.04
AKME65	L	240 V AC	21.55	1300	2.93
AKME65	L	400 V AC	18.27	2500	4.78

Title: Annex to CoC  
IECEx TPS 25.0065X  
Issue No: 0  
Date of Issue: 2026-01-19  
Page 9 of 12



TÜV SÜD Product Service GmbH  
Certification Body for Products  
Ridlerstraße 65  
D-80339 Munich  
Germany

15.6.10 Annex to CoC IECEX TPS 25.0065X - Page 10



**IECEX Certificate of Conformity**



Product Service

**Annex to certificate:** IECEX TPS 25.0065X Issue No: 0  
**Applicant:** A&S Industry Technology (Tianjin) Co., Ltd.  
 No. D9-1/D9-2, Saida International Industrial City  
 Xiqing Economic & Technological District 300385 Tianjin, China  
**Apparatus:** Ex PM SERVOMOTOR  
**Type(s):** AKME series

Model	Winding	Voltage	Rated Torque (Nm)	Rated Speed (rpm)	Rated Power (kW)
AKME65	M	240 V AC	21.13	1500	3.32
AKME65	M	400 V AC	17.83	2700	5.04
AKME65	N	240 V AC	18.96	2000	3.97
AKME65	N	400 V AC	14.95	3500	5.48
AKME65	P	240 V AC	18.15	2400	4.56
AKME65	P	400 V AC	13.71	4000	5.74
AKME72	K	400 V AC	24.12	1500	3.79
AKME72	L	400 V AC	23.27	1500	4.39
AKME72	M	400 V AC	22.55	2000	4.72
AKME72	P	240 V AC	22.83	1800	4.3
AKME72	P	400 V AC	18.91	3000	5.94
AKME72	Q	240 V AC	22.13	2000	4.63
AKME72	Q	400 V AC	14.77	4000	6.19
AKME73	L	400 V AC	33.12	1400	4.86
AKME73	M	400 V AC	32.44	1500	5.1
AKME73	P	240 V AC	33.26	1300	4.53
AKME73	P	400 V AC	26.73	2400	6.72
AKME73	Q	240 V AC	32.02	1500	5.03
AKME73	Q	400 V AC	23.31	3000	7.32
AKME74	L	400 V AC	41.88	1200	5.26
AKME74	P	400 V AC	35.56	1800	6.7
AKME74	Q	240 V AC	40.18	1200	5.47
AKME74	Q	400 V AC	29.2	2500	7.64

Table 2: Connectors used on model type

Title: Annex to CoC  
 IECEX TPS 25.0065X  
 Issue No: 0  
 Date of Issue: 2026-01-19  
 Page 10 of 12



TÜV SÜD Product Service GmbH  
 Certification Body for Products  
 Ridlerstraße 65  
 D-80339 Munich  
 Germany

15.6.11 Annex to CoC IECEX TPS 25.0065X - Page 11



IECEX Certificate of Conformity



Product Service

**Annex to certificate:** IECEX TPS 25.0065X Issue No: 0  
**Applicant:** A&S Industry Technology (Tianjin) Co., Ltd.  
 No. D9-1/D9-2, Saida International Industrial City  
 Xiqing Economic & Technological District 300385 Tianjin, China  
**Apparatus:** Ex PM SERVOMOTOR  
**Type(s):** AKME series

Model	Connector type	Connector Model	Matting connector	Cable series
AKME1 series	Power connector (9pin)	TE Y-TEC 615915 (21 pins)	TE ESTB-202-NN-00-31-0500	P1 & P2
	Feedback connector (12pin)		TE ESTB-002-NN-00-31-0001	F1
	Power connector (9pin)	TE Y-TEC 615915 (24 pins)	TE ESTB-202-NN-00-31-0500	P1 & P2
	Feedback connector (15pin)		TE ESTB-205-NN-00-31-0002	F1
AKME2 series AKME3 series AKME4 series AKME5 series AKME6 series	Power connector (Dual 90° M23)	Phoenix SF-7EP1N8AA500	Phoenix P/N:1605617 SF-7ES1N8A8LDL	P1 & P2
	Hybrid connector (M23)			H2
	Feedback connector (M23)	Phoenix RF-12P2N8AAD00	Phoenix P/N: 1069313 M23-12S2N8A80DU	F1
		Phoenix RF-17P1N8AAD00	Phoenix P/N: 1619754 CA-17S1N8A80DN	F1
AKME7 series	Power connector (Dual 90° M23)	Phoenix SF-7EP1N8AA500	Phoenix P/N:1605617 SF-7ES1N8A8LDL	P1 & P2
	Power connector (90° M40 only for AKME72Q, AKME73Q, AKME74Q)	TE 940	TE CSTA-263-NN-00-26-0001	P1 & P2
	Feedback connector (M23)	Phoenix RF 12P2N8AAD00	Phoenix P/N: 1069313 M23-12S2N8A80DU	F1
		Phoenix RF 17P1N8AAD00	Phoenix P/N: 1619754 CA-17S1N8A80DN	F1

Title: Annex to CoC  
 IECEX TPS 25.0065X  
 Issue No: 0  
 Date of Issue: 2026-01-19  
 Page 11 of 12



TUV SUD Product Service GmbH  
 Certification Body for Products  
 Ridlerstraße 65  
 D-80339 Munich  
 Germany

## 15.6.12 Annex to CoC IECEX TPS 25.0065X - Page 12



### IECEX Certificate of Conformity



Product Service

**Annex to certificate:** IECEX TPS 25.0065X Issue No: 0  
**Applicant:** A&S Industry Technology (Tianjin) Co., Ltd.  
No. D9-1/D9-2, Saida International Industrial City  
Xiqing Economic & Technological District 300385 Tianjin, China  
**Apparatus:** Ex PM SERVOMOTOR  
**Type(s):** AKME series

Warning Label:

WARNING – DO NOT SEPARATE WHEN ENERGIZED  
WARNING – DO NOT CONNECT OR DISCONNECT WHEN ENERGIZED.  
WARNING – WINDING PROTECTED WITH PT1000 DETECTOR  
WARNING – FOR CONVERTER SUPPLY

Routine tests:

Routine tests are required on each piece (100%) during production control:

- 1/ The encapsulated parts of the servomotor shall be subjected to a visual inspection. No visible damage of the compound shall be evident, such as cracks, exposure of the encapsulated parts, flaking, impermissible shrinkage, discoloration, swelling decomposition or softening, as required by IEC 60079-18:2017, Clause 9.1
- 2/ The servomotor shall be subjected to a dielectric strength test with 1800 V AC for least 60 s without dielectric breakdown occurring. Alternatively, the test may be carried out at 2160 V AC for at least 100 ms. The testing must follow Clause 9.2 of IEC 60079-18:2017 and Clause 7.1 of IEC 60079-7:2017.  
No flashover or electric breakdown occurring.

Title: Annex to CoC  
IECEX TPS 25.0065X  
Issue No: 0  
Date of Issue: 2026-01-19  
Page 12 of 12



TÜV SÜD Product Service GmbH  
Certification Body for Products  
Ridlerstraße 65  
D-80339 Munich  
Germany

## 16 Motors - Copyrights, Trademarks, and Disclaimers

Copyright 2026 Regal Rexnord Corporation, All Rights Reserved.

Information in this document is subject to change without notice. The software package described in this document is furnished under a license agreement. The software package may be used or copied only in accordance with the terms of the license agreement.

This document is the intellectual property of Kollmorgen and contains proprietary and confidential information. The reproduction, modification, translation or disclosure to third parties of this document (in whole or in part) is strictly prohibited without the prior written permission of Kollmorgen.

### 16.1 Kollmorgen Trademarks

Regal Rexnord and [Kollmorgen](#) are trademarks of [Regal Rexnord Corporation](#) or one of its affiliated companies.

These trademarks or trade names are owned by or under the control of Regal Rexnord Corporation or any of its affiliates:

- Kollmorgen Essentials System
- Kollmorgen Essentials Cable
- Kollmorgen Essentials Drive
- Kollmorgen Essentials Motor
- AKD
- AKD2G
- AKD PDMM
- AKM
- AKMA
- AKME
- AKMH
- BLM
- DDL
- Goldline
- Kollmorgen Automation Suite
- KAS
- Kollmorgen Visualization Builder
- KVB
- MKD
- P8000
- PCMM
- PCMM2G
- SafeMotion Monitor
- SMM
- TBM
- TBM2G
- WorkBench

## 16.2 Other Trademarks

Any of these other trademarks and/or trade names may be used and/or identified in Kollmorgen products, firmware, and/or software.

These are believed to be the trademarks and/or trade names of their respective owners and are not owned or controlled by Regal Rexnord Corporation:

- BiSS: iC-Haus GmbH.
- CANopen: CAN in Automation (CiA).
- DRIVE-CLiQ: Siemens Aktiengesellschaft.
- EnDat: Dr. Johannes Heidenhain GmbH.
- EtherCAT and Safety over EtherCAT: Beckhoff Automation GmbH.
- EtherCAT: Beckhoff Automation GmbH.
- EtherNet/IP Communication Stack: Rockwell Automation.
- EtherNet/IP: ODVA, Inc.
- [Ghostsript](#): Artifex Software, Inc. (distributed under the [AGPL](#) license).
- HIPERFACE DSL: SICK AG.
- HIPERFACE: SICK AG.
- Hysol: Hysol Huawei Electronics Co.,LTD.
- IECEx: International Electrotechnical Commission (IEC).
- Instapak: Sealed Air Corporation.
- INTERCONTEC: INTERCONTEC Pfeiffer Industrie-Steckverbindungen GmbH.
- LOCTITE 640: Henkel AG & CO. KGAA.
- LOCTITE: Henkel AG & CO. KGAA.
- Modbus: Schneider Electric USA, Inc.
- MOLYKOTE: DDP Specialty Electronic Materials US 9, LLC.
- Mylar: DUPONT Teijin Films U.S.
- PHOENIX CONTACT: Phoenix Contact GmbH & Co. KG.
- PROFINET: PROFIBUS Nutzerorganisation e.V.
- Scotch-Weld 2214: 3M Company.
- sercos: Sercos International E.V.
- SIMATIC: Siemens Aktiengesellschaft.
- SpeedTec: Liqui-Moly GmbH or TE Connectivity Industrial GmbH.  
If SpeedTec is used as a lubricant, it belongs to Liqui-Moly GmbH.  
If SpeedTec is used as a connector, it belongs to TE Connectivity Industrial GmbH
- Teflon: The Chemours Company FC, LLC.
- Windows: Microsoft Corporation.

## 16.3 Disclaimers

### **Technical changes which improve the performance of the device may be made without prior notice!**

This document is the intellectual property of Kollmorgen. All rights reserved. No part of this work may be reproduced in any form (by photocopying, microfilm or any other method) or stored, processed, copied or distributed by electronic means without the written permission of Kollmorgen.

The information in this document is believed to be accurate and reliable at the time of its release. Kollmorgen assumes no responsibility for any damage or loss resulting from the use of this help, and expressly disclaims any liability or damages for loss of data, loss of use, and property damage of any kind, direct, incidental or consequential, in regard to or arising out of the performance or form of the materials presented herein or in any software programs that accompany this document.

### **Technische Änderungen, die der Verbesserung der Geräte dienen, vorbehalten!**

Dieses Dokument ist geistiges Eigentum von Kollmorgen. Alle Rechte vorbehalten. Kein Teil dieses Werkes darf in irgendeiner Form (Fotokopie, Mikrofilm oder in einem anderen Verfahren) ohne schriftliche Genehmigung von Kollmorgen reproduziert oder unter Verwendung elektronischer Systeme verarbeitet, vervielfältigt oder verbreitet werden.

Die Genauigkeit und Verlässlichkeit der Informationen in diesem Dokument entspricht dem Kenntnisstand zum Zeitpunkt der Veröffentlichung. Kollmorgen übernimmt keine Verantwortung für Schäden oder Verluste, die sich aus der Verwendung dieser Hilfe ergeben, und lehnt ausdrücklich jegliche Haftung sowie Schadensersatzansprüche für Datenverlust, entgangene Nutzung und Sachschäden jeglicher Art ab, inklusive direkter, zufälliger oder Folgeschäden im Zusammenhang mit der Funktion oder Form des hierin oder in einem der mit diesem Dokument gelieferten Software enthaltenen Materials.

### **Es posible que se implementen sin aviso previo cambios técnicos que mejoran el rendimiento del dispositivo.**

La propiedad intelectual de este documento pertenece a Kollmorgen. Todos los derechos reservados. Se prohíbe la reproducción de este documento por ningún medio (fotocopia, microfilm u otro método), así como su almacenamiento, procesamiento, copia o distribución por medios electrónicos, sin el consentimiento por escrito de Kollmorgen.

La información incluida en este documento se considera correcta y confiable en el momento de su publicación. Kollmorgen no asume ninguna responsabilidad por ningún daño o pérdida causados por el uso de este documento de ayuda y rechaza explícitamente toda responsabilidad o daño por pérdida de datos, pérdida de uso y daños en la propiedad de cualquier tipo, ya sea directos, incidentales o consecuentes, en relación con el rendimiento o la forma de los materiales aquí publicados, o con los programas de software que acompañan a este documento, o que surjan de estos.

### **Les modifications techniques qui améliorent les performances du dispositif peuvent être apportées sans avis préalable !**

Ce document est la propriété intellectuelle de Kollmorgen. Tous droits réservés. Aucune partie de ce document ne peut être reproduite sous quelque forme que ce soit (photocopie, microfilm ou autre méthode) ni stockée, traitée, copiée ou distribuée de manière électronique sans l'autorisation écrite de Kollmorgen.

Les informations contenues dans ce document sont considérées exactes et fiables au moment de leur publication. Kollmorgen n'assume aucune responsabilité pour tout dommage ou perte résultant de l'utilisation de cette aide, et rejette expressément toute responsabilité ou tous dommages pour la perte de données, la perte d'utilisation et les dommages matériels de toute nature, directs, accessoires ou indirects, en ce qui concerne ou découlant des performances ou de la forme des matériaux présentés ici ou dans tout programme logiciel accompagnant ce document.

**Modifiche tecniche volte a migliorare le prestazioni del dispositivo possono essere apportate senza preavviso.**

Il presente documento è proprietà intellettuale di Kollmorgen. Tutti i diritti riservati. È vietata la riproduzione di qualsiasi parte di quest'opera in qualsiasi forma (fotocopia, microfilm o qualunque altro metodo) così come la memorizzazione, il trattamento, la copia o la distribuzione tramite mezzi elettronici senza l'autorizzazione scritta di Kollmorgen.

Le informazioni contenute nel presente documento sono ritenute accurate e affidabili al momento della pubblicazione. Kollmorgen non si assume alcuna responsabilità per eventuali danni o perdite risultanti dall'uso di questa guida e declina espressamente qualsiasi responsabilità o danni dovuti a perdita di dati, mancato utilizzo e danni materiali di qualunque tipo, diretti, accidentali o consequenziali, in relazione a o derivanti dal funzionamento o dalla forma dei materiali presentati qui o in eventuali programmi software che accompagnano il presente documento.

デバイスの性能の向上のため、予告なく技術的な変更が実装される場合があります。

本書の知的財産権はKollmorgenに帰属しており、無断複写・転載は禁じられています。本書のいずれの部分も、Kollmorgenの書面による許可なしに、いかなる複製(写真、マイクロフィルムまたはその他の手段)、保管、改変、複製または電子的配布を行うことはできません。

本書に記載されている情報は、発行時において正確かつ信頼できるものですが、Kollmorgenはこのヘルプの使用により生じるいかなる損害や損失についても責任を負いません。また、本書の履行、資料形式または付随するあらゆるソフトウェアプログラムに関連して、あるいはこれらが原因で発生する、直接的、偶発的または結果的な、いかなるデータの損失、利用機会の喪失および財産の損害に対しても、一切の責任や損害賠償を明示的に否認します。

**기기의 성능을 향상시키는 기술적 변경 사항은 사전 공지 없이 이루어질 수 있습니다!**

본 문서의 지적 재산권은 Kollmorgen에 있습니다. All rights reserved. 본 저작물의 어떤 부분도 Kollmorgen의 서면 허가 없이 어떠한 형태(사진 복사, 마이크로필름 또는 기타 방법)로든 복제하거나 전자 수단으로 저장, 처리, 복사 또는 배포할 수 없습니다.

본 문서의 정보는 공개 시점을 기준으로 정확하고 신뢰할 수 있는 것으로 간주됩니다. Kollmorgen은 본 도움말의 사용으로 인한 어떠한 피해나 손실에 대해 책임을 지지 않으며, 본 문서 또는 본 문서와 함께 제공되는 소프트웨어 프로그램에 제시된 자료의 성능 또는 형태와 관련하여 또는 그로 인해 직접적, 우발적 또는 결과적으로 발생한 모든 유형의 데이터 손실, 사용 손실, 재산상의 피해에 대한 책임이나 손해를 명시적으로 부인합니다.

**Alterações técnicas que melhoram o desempenho do dispositivo podem ser feitas sem aviso prévio!**

Este documento é propriedade intelectual da Kollmorgen. Todos os direitos reservados. Nenhuma parte deste trabalho pode ser reproduzida sob qualquer forma (por fotocópia, microfilme ou qualquer outro método) ou armazenada, processada, copiada ou distribuída por meios eletrônicos sem a permissão escrita da Kollmorgen.

Acredita-se que as informações contidas neste documento sejam precisas e confiáveis no momento de sua divulgação. A Kollmorgen não assume nenhuma responsabilidade por quaisquer danos ou perdas resultantes do uso desta ajuda, e se isenta expressamente de qualquer responsabilidade ou danos por perda de dados, perda de uso e danos materiais de qualquer espécie, direta, incidental ou subsequente em relação a ou resultante do desempenho ou da forma dos materiais apresentados aqui ou em quaisquer programas de software que acompanhem este documento.

**我们可能会进行技术更改以提高设备性能，恕不另行通知!**

本文档知识产权归 Kollmorgen 所有，Kollmorgen 保留所有权利。未经 Kollmorgen 书面许可，不得以任何形式（影印、缩微胶片或其他任何方式）复制本文档任何内容，亦不得以任何电子手段存储、处理、复制或分发本文档的任何内容。

据我们所知，本文档所含信息截至发布日是准确可靠的。对于因使用本帮助文档而导致的任何损害或损失，Kollmorgen 概不承担任何责任。Kollmorgen 特此明确声明，对于因本文档中的任何材料或随附本档之任何软件程序的性能或形式导致的或与之相关的任何类型的数据丢失、使用中断损失或财产损失（包括直接、间接和衍生性损失或损害），Kollmorgen 不承担任何法律责任或损害赔偿赔偿责任。

# Support and Services

## About Kollmorgen

When you need motion and automation systems for your most demanding applications and environments, count on Kollmorgen - the innovation leader for more than 100 years. We deliver the industry's highest-performing, most reliable motors, drives, AGV control solutions and automation platforms, with over a million standard and easily modifiable products to meet virtually any motion challenge. We offer manufacturing facilities, distributors and engineering expertise in all major regions around the world, so you can bring a better machine to market faster and keep it profitable for many years to come.

## Kollmorgen Support Network



See the [Kollmorgen Support Network](#) for product support, product downloads, knowledge base answers, and information.



## Kollmorgen Support Locations

### North America

**Kollmorgen Corporation**  
201 West Rock Road  
Radford, VA 24141, USA

**Web:** [www.kollmorgen.com](http://www.kollmorgen.com)  
**Email:** [kollmorgen.support@regalrexnord.com](mailto:kollmorgen.support@regalrexnord.com)  
**Tel.:** +1-540-633-3545  
**Fax:** +1-540-639-4162

### Europe

**Kollmorgen Europe GmbH**  
Pempelfurtstr. 1  
40880 Ratingen, Germany

**Web:** [www.kollmorgen.com](http://www.kollmorgen.com)  
**Email:** [Technical.Support.EU@regalrexnord.com](mailto:Technical.Support.EU@regalrexnord.com)  
**Tel.:** +49-2102-9394-0  
**Fax:** +49-2102-9394-3155

### South America

**Altra Industrial Motion do Brasil**  
**Equipamentos Industriais Ltda.**  
Avenida João Paulo Ablas, 2970  
Jardim da Glória, Cotia – SP  
CEP 06711-250, Brazil

**Web:** [www.kollmorgen.com](http://www.kollmorgen.com)  
**Email:** [kollmorgen.contato@regalrexnord.com](mailto:kollmorgen.contato@regalrexnord.com)  
**Tel.:** (+55 11) 4615-6300

### China and SEA

**Kollmorgen (Shanghai)**  
Room 1201, Building A,  
Mangoo Hub, No.7 Longai Road,  
Xuhui District, Shanghai, China  
(Service available in English and Chinese)

**Web:** [www.kollmorgen.cn](http://www.kollmorgen.cn)  
**Email:** [kollmorgen.motion.sales.china@regalrexnord.com](mailto:kollmorgen.motion.sales.china@regalrexnord.com)  
**Tel.:** +86-400 668 2802

# KOLLMORGEN

A REGAL REXNORD BRAND