

AKD™/S700

Accessories Guide

North American Edition



Edition: September 2013, North America, Revision F

Part Number: 903-200007-00

Original Document



Keep all manuals as a product component during the life span of the product.
Pass all manuals to future users/owners of the product.

KOLLMORGEN®

Because Motion Matters™

Record of Document Revisions

Revision	Remarks
Rev A, 12/2009	Original version
Rev B, 08/2012	Updated revision
Rev C, 09/2012	Minor updates to formatting.
Rev D, 09/2012	Minor updates to formatting.
Rev E, 05/2013	Notes added on 300V and 600V Value line cable routing standards. Chapter on capacitor modules added.
Rev F, 09/2013	Pinout drawings added for linear motor adapters. Section added for Kollmorgen Ethernet cables.

EnDat is a registered trademark of Dr. Johannes Heidenhain GmbH

EtherCAT® is registered trademark and patented technology, licensed by Beckhoff Automation GmbH, Germany.

Windows is a registered trademark of Microsoft Corporation

AKD is a registered trademark of Kollmorgen™ Corporation

Current patents:

US Patent 5,646,496 (used in control card R/D and 1 Vp-p feedback interface)

US Patent 5,162,798 (used in control card R/D)

US Patent 6,118,241 (used in control card simple dynamic braking)

Technical changes which improve the performance of the device may be made without prior notice.

Printed in the United States of America

This document is the intellectual property of Kollmorgen™. All rights reserved. No part of this work may be reproduced in any form (by photocopying, microfilm or any other method) or stored, processed, copied or distributed by electronic means without the written permission of Kollmorgen™.

Table of Contents

Table of Contents	3
1 General	6
1.1 About this Manual	6
1.2 Symbols	6
1.3 General Safety Instructions	6
2 Digital Drive Systems	8
2.1 Drive System with AKD-P00306 to 02406	8
2.2 Drive System with AKD-P00307 to 02407	9
2.3 Drive System with S701 to 724	10
2.4 Drive System with S748 to S772	11
3 Mechanical Tools	12
3.1 Safety instructions	12
3.1.1 Suspension Unit for AKM8 motors	12
3.2 Mounting clamps for side mounting of S701-712 and S724	13
3.2.1 Clamp for S701-712, 70mm	13
3.2.2 Clamp for S724, 100mm	14
4 Input, Output, and Feedback Accessories	15
4.1 AKD Control Box, AKD-CONTROLBOX-A	15
4.2 X9 Screw Terminal Adapter, AKD-X9ADPT	15
4.3 Linear Motor Adapter	15
4.3.1 ACI-AKD-A Pinout Drawing	16
4.3.2 ACI-AKD-B Pinout Drawing	16
5 Shielding Accessories	17
5.1 Safety instructions	17
5.2 Shield Plates	17
5.2.1 AKD-z-zzz06 shield plate	17
5.2.2 AKD-z-00307, AKD-z-00607, and AKD-z-01207 shield plate	18
5.2.3 AKD-z-02407 shield plate	18
5.3 AKD and S701 to S724 Shield Clamps (purchased separately)	19
5.4 S748 to S772 Shield Clamps (purchased separately)	19
5.5 External Shielding Busbar (purchased separately)	20
6 Mains Chokes	22
6.1 Safety instructions	22
6.2 Type assignment	22
6.3 Order codes	22
6.4 Mains choke 3L	23
7 Mains Filters	24
7.1 Safety instructions	24
7.2 Type assignment	24
7.3 Order codes	25
7.4 Mains filters FN2320Y-10-06 and FN2070-12-06	25
7.5 Mains filters FN3258-7-45, FN3258-16-45, and FN3258-30-47	27
8 Capacitor Modules	28
8.1 Important Notes	28

8.2	Order codes	28
8.3	Technical Data	29
8.4	External regen resistor BAFP(U)	29
9	Brake/Regeneration Resistors	31
9.1	Safety Instructions	31
9.2	Type assignment	31
9.3	Order codes	32
9.4	External regen resistor BAFP(U)	33
9.5	External regen resistor BAR(U)	34
9.6	External regen resistor BAS(U)	35
10	Motor Chokes	37
10.1	Shielded motor cables	37
10.2	Safety Instructions	38
10.3	Type assignment	38
10.4	Motor choke 3YLN-xx	39
11	Cables	40
11.1	PC connection	40
11.2	Kollmorgen Ethernet Cables	40
11.3	CANopen Bus Cables for AKD	41
11.4	Motor Power and Feedback Cables	41
11.4.1	Order Codes for S700 Motor Power Cables	42
11.4.1.1	S701-712 Order Codes	42
11.4.1.2	S724 Order Codes	43
11.4.1.3	S748 Order Codes	43
11.4.2	Preparing Motor Cables (Motor End)	44
11.4.2.1	Motor Series AKM2...8, 6SMx7, DBL2...6, DBK	44
11.4.3	Preparing Cables for Drive (S701 to S724)	45
11.5	CANopen Bus Cable Specifications	45
11.5.1	CANopen Cable P-AKD-CAN-RJ-z-zz	46
11.5.2	CANopen Cable P-AKD-CAN-TERM	46
11.5.3	CANopen Cable PAKD-CAN-9D-0-15	47
11.5.4	CANopen Cable PAKD-CAN-FL-3-00	47
11.6	Motor Power Cable Specifications	48
11.6.1	Cable Routing Standards	48
11.6.2	AKD 1.5 – 6 A Power Cable, VP-507BEAN-xx	48
11.6.3	AKD 12 A Power Cable, VP-508CEAN-zz	49
11.6.4	AKD 12 A Power Cable with Brake, VP-508CFAN-zz	50
11.6.5	AKD 24 A Power Cable with Brake, VP-508DEAN-zz	51
11.6.6	AKD 24 A Power Cable with Brake, VP-508DFAN-zz	52
11.7	Motor Feedback Cable Specifications	54
11.7.1	Cable Routing Standards	54
11.7.2	Motor Feedback Cable, VF-DA0-474N-zz	54
11.7.3	Feedback Resolver Cable, VF-RA2474N-zz	55
11.7.4	Sine Encoder Feedback Cable, VF-SB4474N-zz	56
11.7.5	Resolver Cables for S700/AKD	57

11.7.5.1 Resolver Cable Order Codes	57
11.7.5.2 Preparing Resolver Cables	57
11.7.6 Encoder Cables for S700/AKD	58
11.7.6.1 Encoder Cable Order Codes	58
11.7.6.2 Preparing Encoder Cables	58
11.7.7 ComCoder Cables for S700/AKD	60
11.7.7.1 ComCoder Cable Order Codes	60
11.7.7.2 Preparing Comcoder Cable	60





1 General

1.1 About this Manual

This manual describes accessories for the AKD and S700 drives and contains essential technical data. This manual is only valid in conjunction with the manuals for the AKD drive and applicable motor in your application.

The manuals for AKD and S700 drives are included on the disk shipped with the drives and on the Kollmorgen website (www.kollmorgen.com). These documents are available in PDF format in multiple languages (system requirements: Windows, internet browser, and Acrobat Reader). In all pdf versions, the table of contents and index entries are active bookmarks. Page/chapter numbers in the text with cross references are active links to the target material.

1.2 Symbols

Symbol	Meaning
 DANGER	Indicates a hazardous situation which, if not avoided, will result in death or serious injury.
 WARNING	Indicates a hazardous situation which, if not avoided, could result in death or serious injury.
 CAUTION	Indicates a hazardous situation which, if not avoided, could result in minor or moderate injury.
 NOTICE	Indicates situations which, if not avoided, could result in property damage.
 NOTE	This is not a safety symbol. This symbol indicates important notes.

1.3 General Safety Instructions

CAUTION

- This manual is only valid in conjunction with the manuals for the drive and motor in your application.
- You must read the installation manual for the drive and motor in your application and observe the safety instructions in this manual before beginning mounting/installation work.
- Improper or incorrect cable assembly, mounting, or wiring can result in damage to property and equipment or personnel injury. The following requirements for specialist personnel apply:

Transport: only by personnel with knowledge of handling electrostatically sensitive components.

Unpacking: only by electrically qualified personnel.

Cable assembly: only by electrically qualified personnel.

Installation: only by electrically qualified personnel.

Commissioning: only by qualified personnel with extensive knowledge of electrical engineering /drive technology.

- Observe the specific safety instructions for each product group.
- The maximum cable lengths that are given must not be exceeded, otherwise the drive and motors may not function properly.



- Kollmorgen is not liable for faults or damage to the connected equipment caused by cables that have been configured by customers.

2 Digital Drive Systems

The systems shown are possible scenarios for setting up a digital drive system with relevant components.

2.1 Drive System with AKD-P00306 to 02406

- Shielded Cable
- Electrical Ground
- Optional Devices

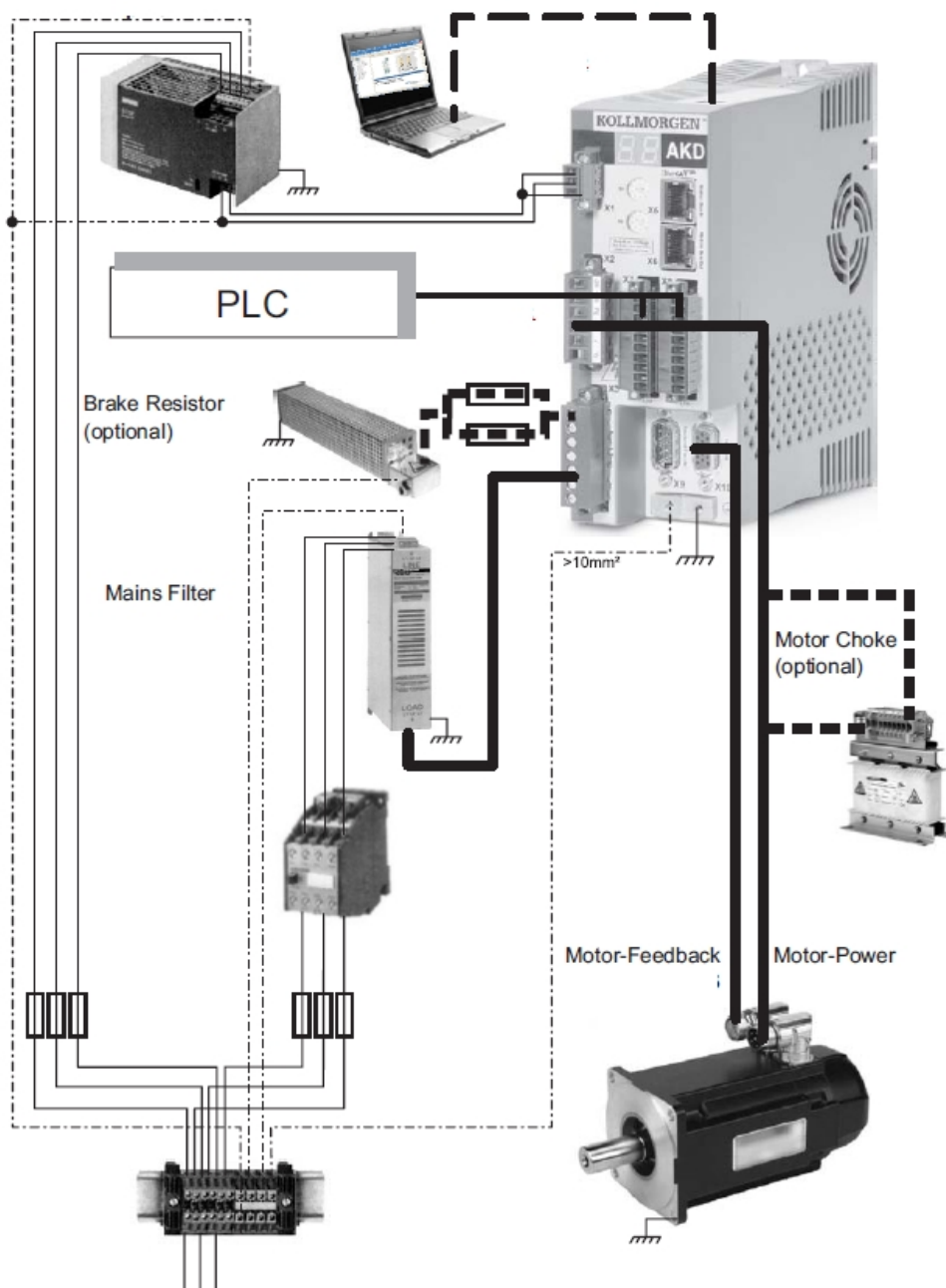

2.2 Drive System with AKD-P00307 to 02407

Shielded Cable ————
 Electrical Ground - - - - -
 Optional Devices - - - - -

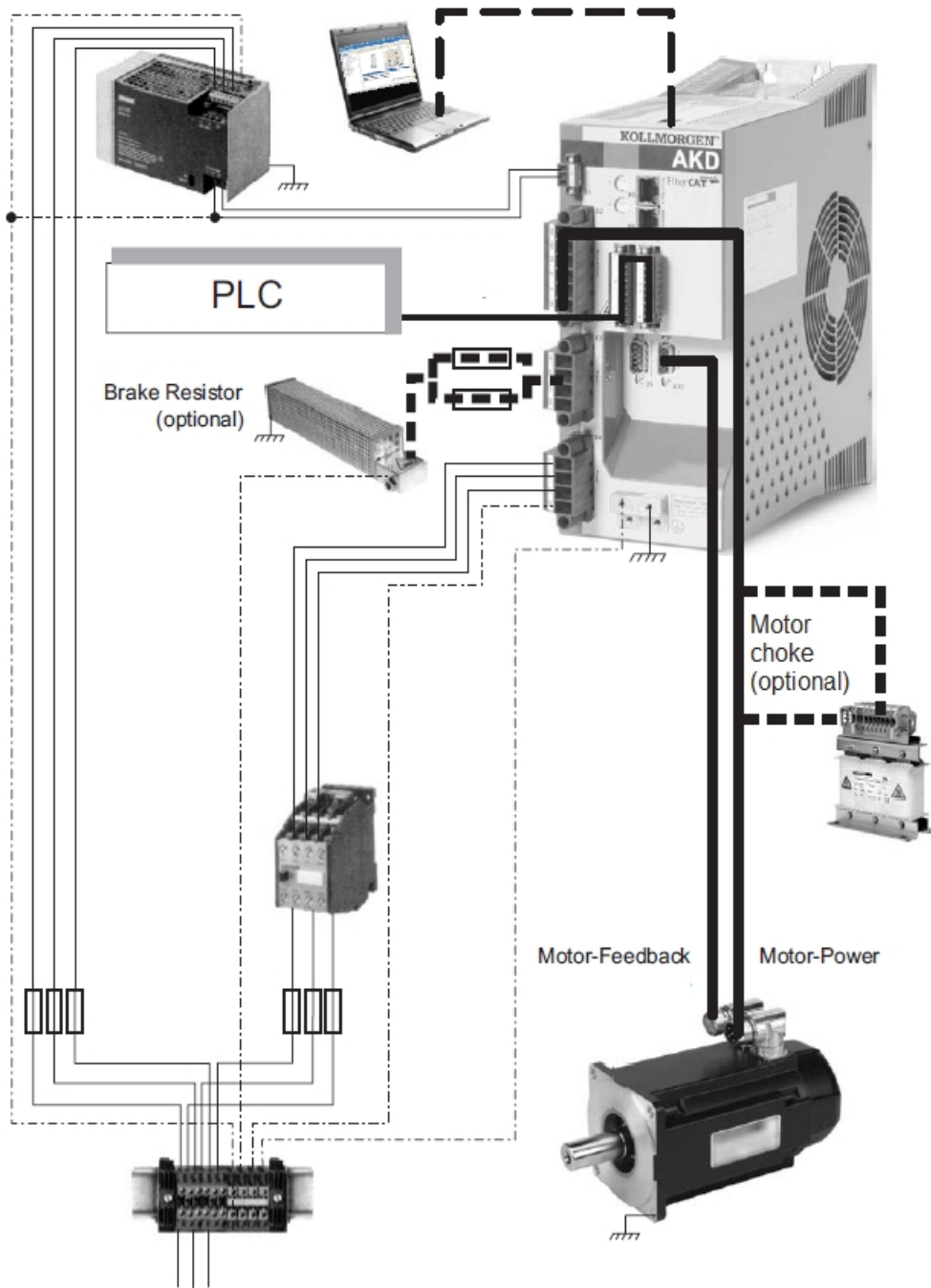

2.3 Drive System with S701 to 724

Shielded Cable ———
 Electrical Ground - - - - -
 Optional Devices - - - - -

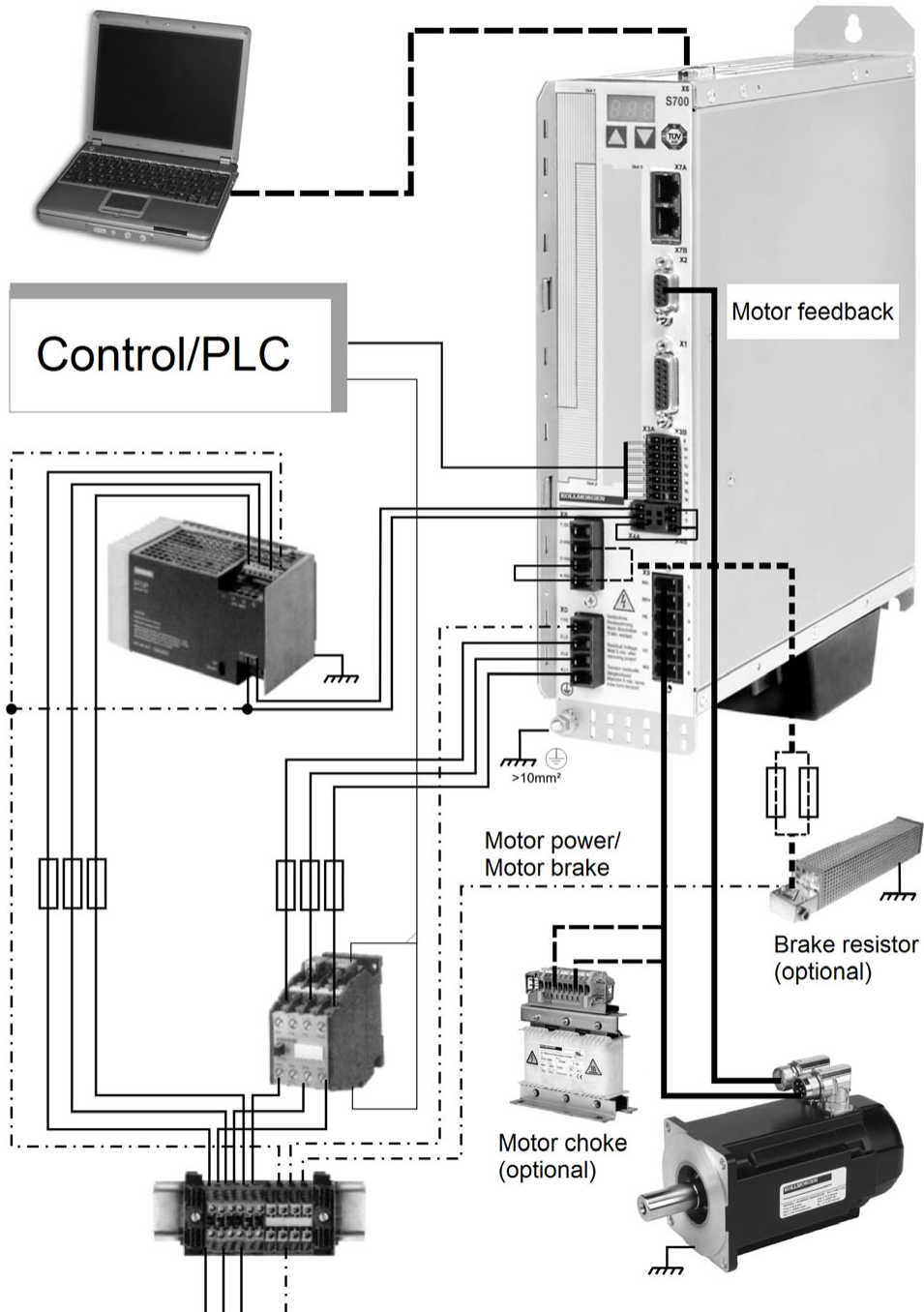

2.4 Drive System with S748 to S772

Shielded Cable ————
 Electrical Ground - - - - -
 Optional Devices - - - - -

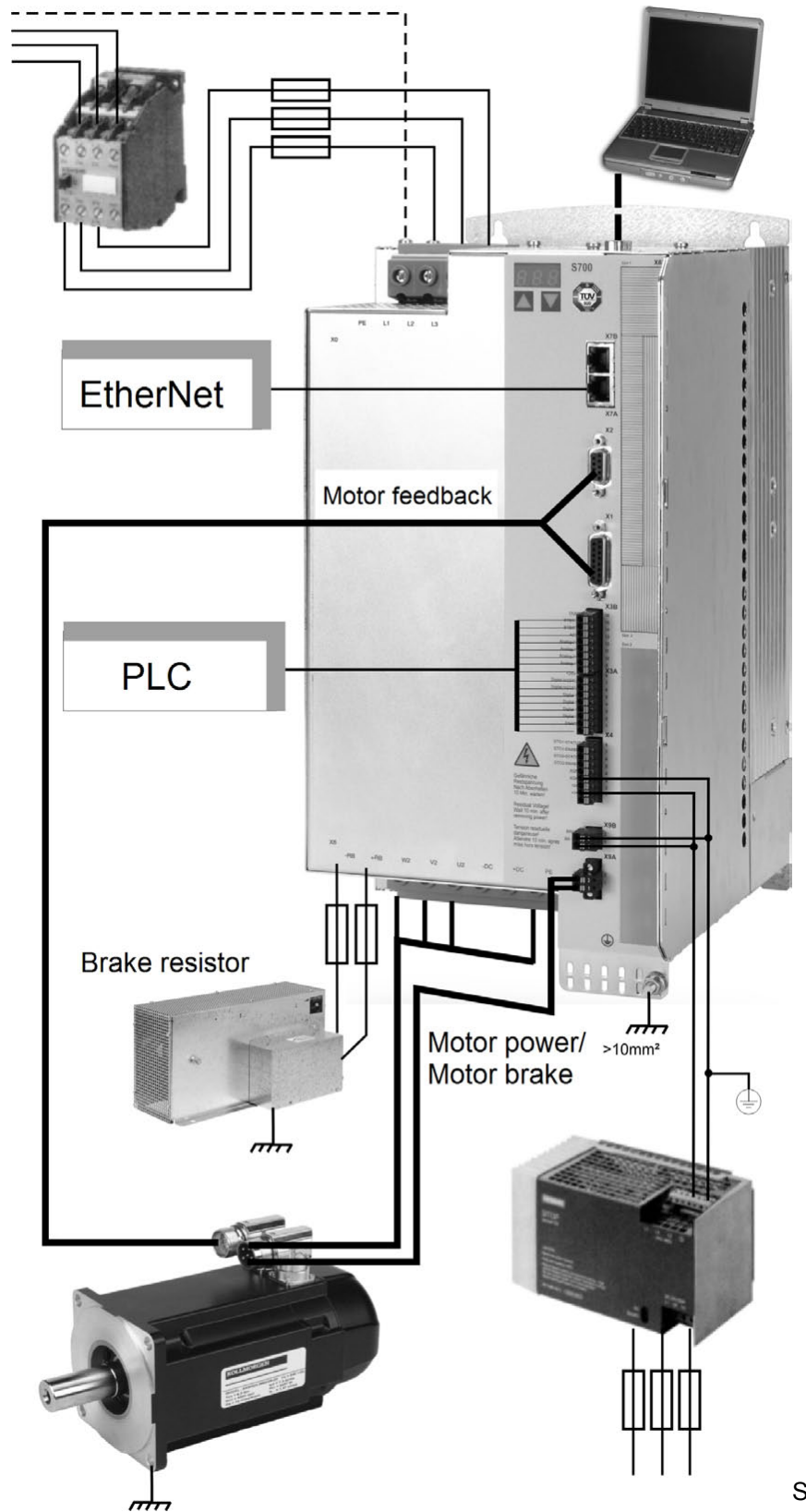

3 Mechanical Tools

3.1 Safety instructions

CAUTION This manual is only valid in conjunction with the instruction manual for the drive and motor you are using in your application.

3.1.1 Suspension Unit for AKM8 motors

CAUTION You must read the instruction manual for the suspension unit ZPMZ 120/292. Observe and follow the safety instructions for this item.

The Suspension Unit ZPMZ 120/292 is designed for suspending motors only, without attached units such as gearboxes, and clutches. The suspension unit is designed for a maximum motor weight of 120 kg and maximum nominal span of the extreme suspension hooks of 292 mm.

The suspension unit consists of a beam (suspended off the crane hook) and two double-run chain suspenders. The motor may be suspended on two or four runs of the chain suspender.

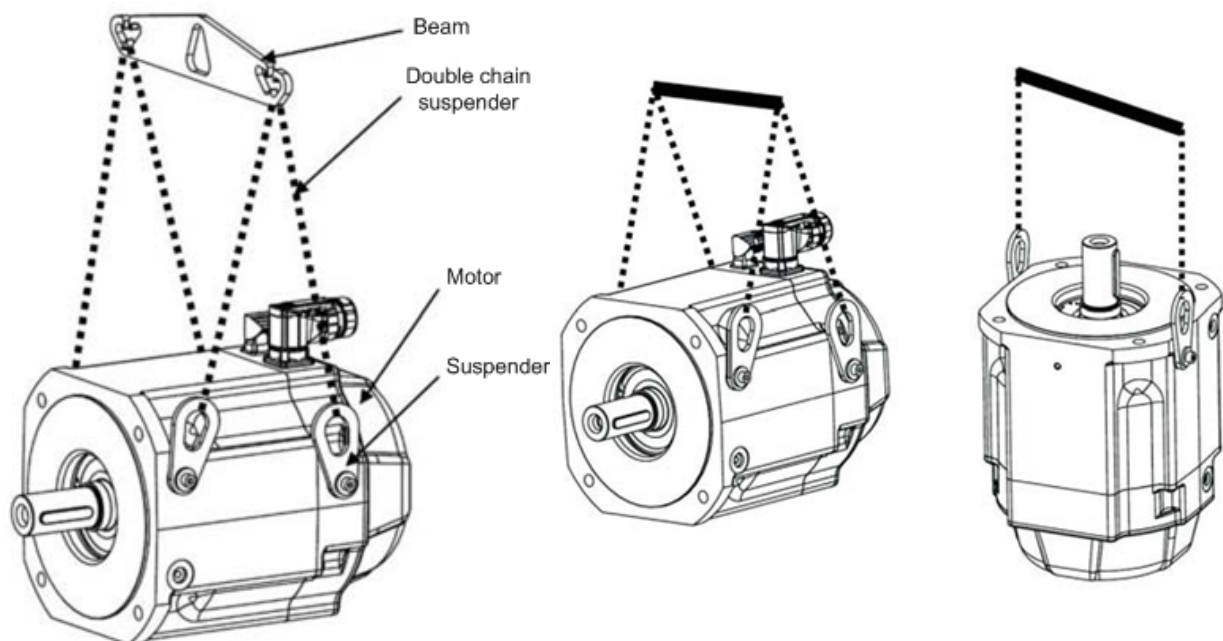

The suspenders (number depends on the motor type) are delivered with the motor.

Technical Data	Value
Lifting capacity	120 kg
Nominal span	292 mm
Lug width	44.7 mm
Lug height	51 mm
Weight	0.83 kg
Number of cycles per year	20,000
Average load	60 %
Order code	FA00092

3.2 Mounting clamps for side mounting of S701-712 and S724



You can mount S700 drives to side walls or doors of switchgear cabinets using an additional mounting clamp. The S701-712 drives requires a 70 mm clamp and the S724 requires a 100 mm clamp.

Technical Data for Clamps

Technical Data	70 mm clamp	100 mm clamp
Mounting holes	5.5 mm	5.5
Height	322 mm	370
Width	72 mm	102
Depth	248 mm	248
Weight	0.13 kg	0.14
Order code	DE-201402	DE-201403

3.2.1 Clamp for S701-712, 70mm

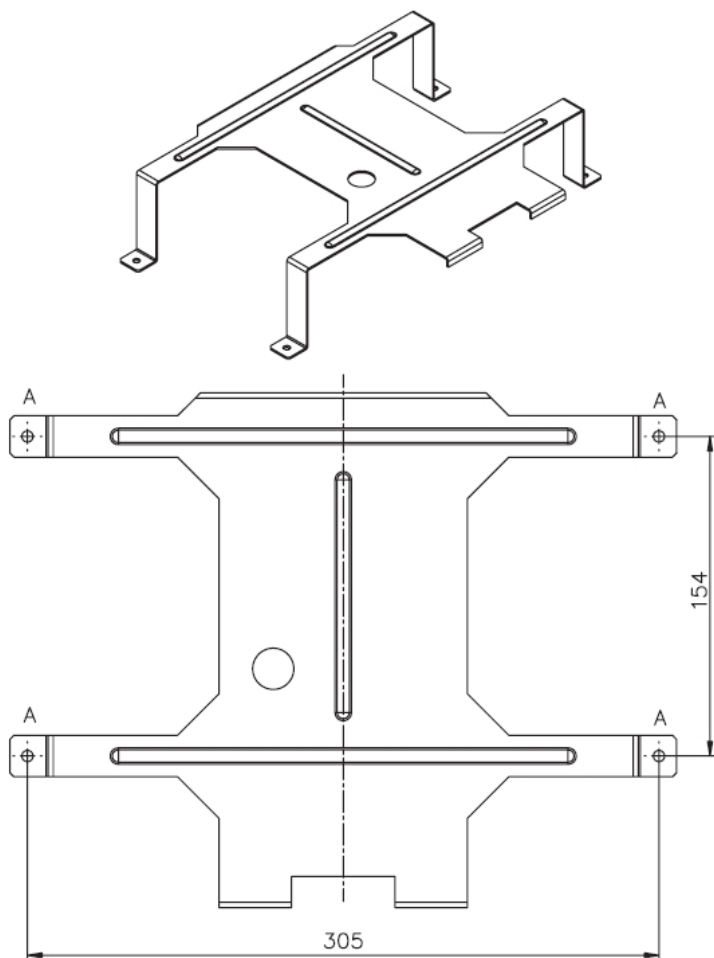

3.2.2 Clamp for S724, 100mm

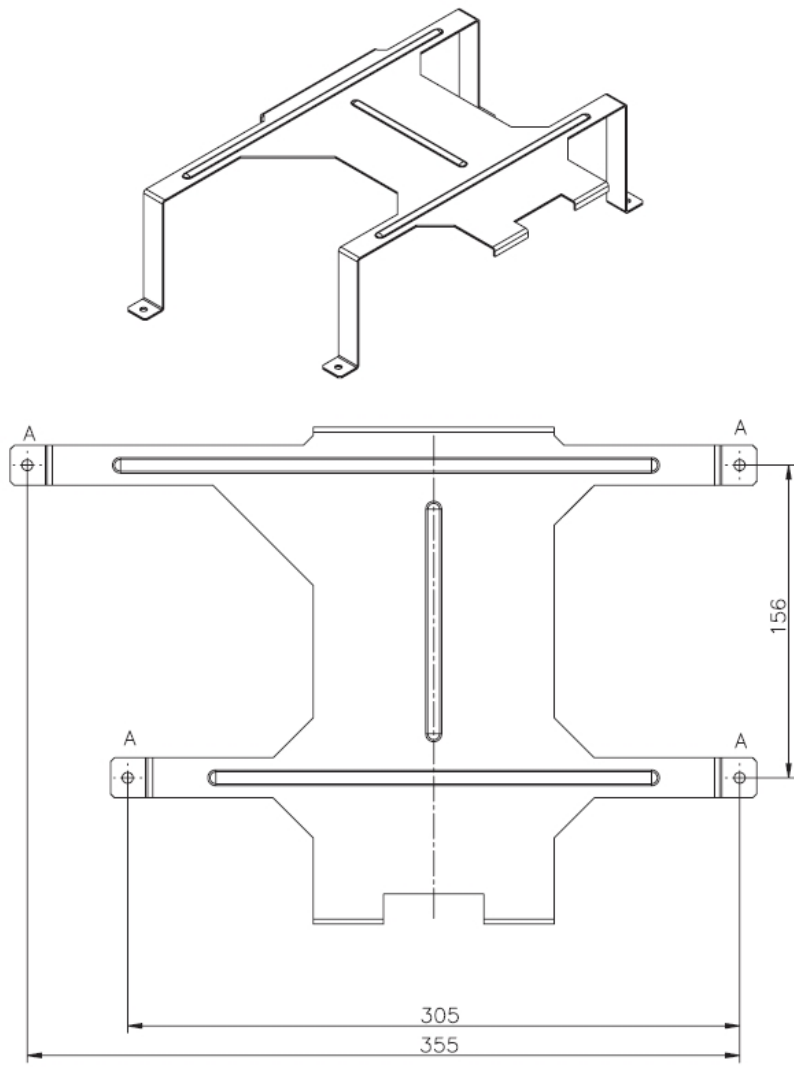

4 Input, Output, and Feedback Accessories

4.1 AKD Control Box, AKD-CONTROLBOX-A

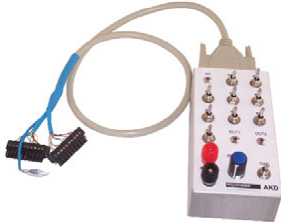

The AKD control box is a test instrument that allows you to control all digital and analog inputs on the drive and to monitor the digital and analog outputs.

4.2 X9 Screw Terminal Adapter, AKD-X9ADPT



The AKD X9 screw terminal adapter plugs into the X9 port for testing of the X9 port connection. This item is not used with S700 drives.

4.3 Linear Motor Adapter



Linear motor adapters are used to combine feedback, Hall, and thermal sensors. They have connectors for standard Kollmorgen DDL connections. The linear feedback device is customer supplied, and two different adapter models are available for common linear feedback types. This item is not used with S700 drives.

Item	Linear Feedback Type
ACI-AKD-A	Heidenhain
ACI-AKD-B	Renishaw

4.3.1 ACI-AKD-A Pinout Drawing

ACI-AKD-A (Heidenhain type)

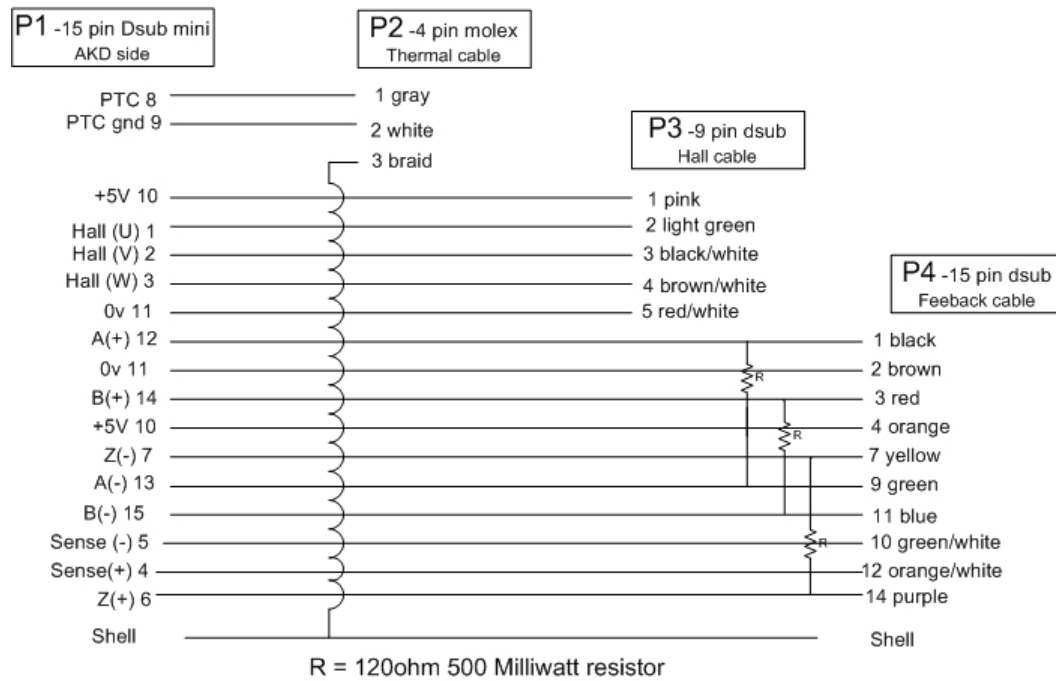

4.3.2 ACI-AKD-B Pinout Drawing

ACI-AKD-B (Renishaw Sine/Cos type)

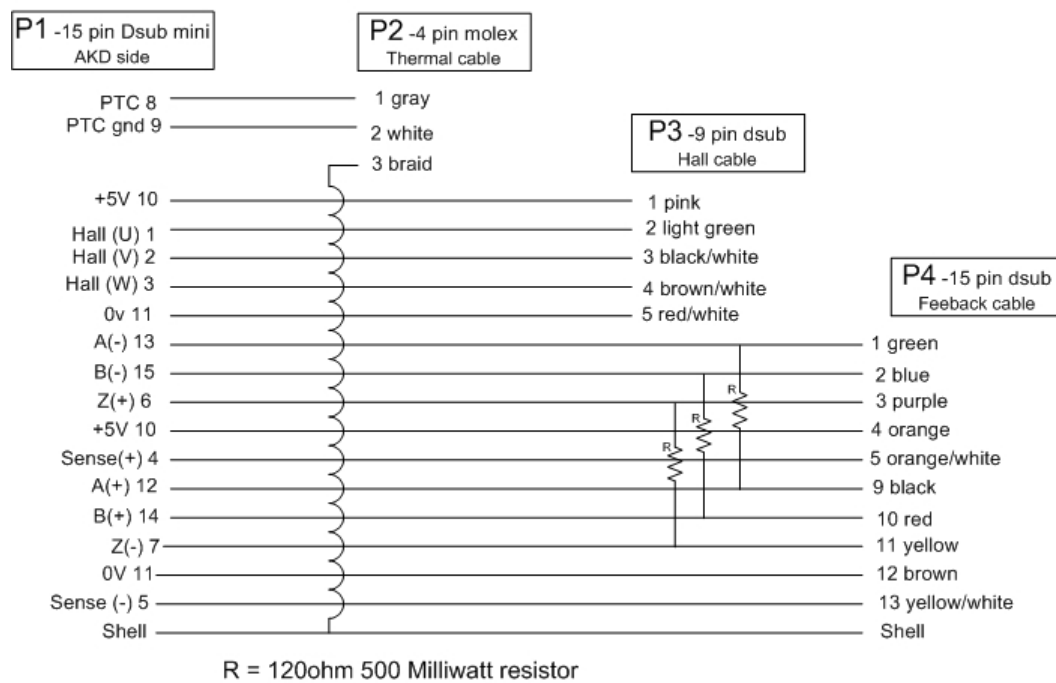

5 Shielding Accessories

5.1 Safety instructions

CAUTION

- You must read the instructions manual for the drive/motor you are using in your application and observe the safety instructions they contain before beginning mounting/installation work.
- This manual is only valid in conjunction with the instruction manuals for the drive and motor you are using in your application.

5.2 Shield Plates

Shield plates can be attached to drives to assist in grounding and routing cabling.



5.2.1 AKD-z-zzz06 shield plate

This shield plate is not included with AKD-z-zzz06, but can be ordered separately (Item 153-230000-01).

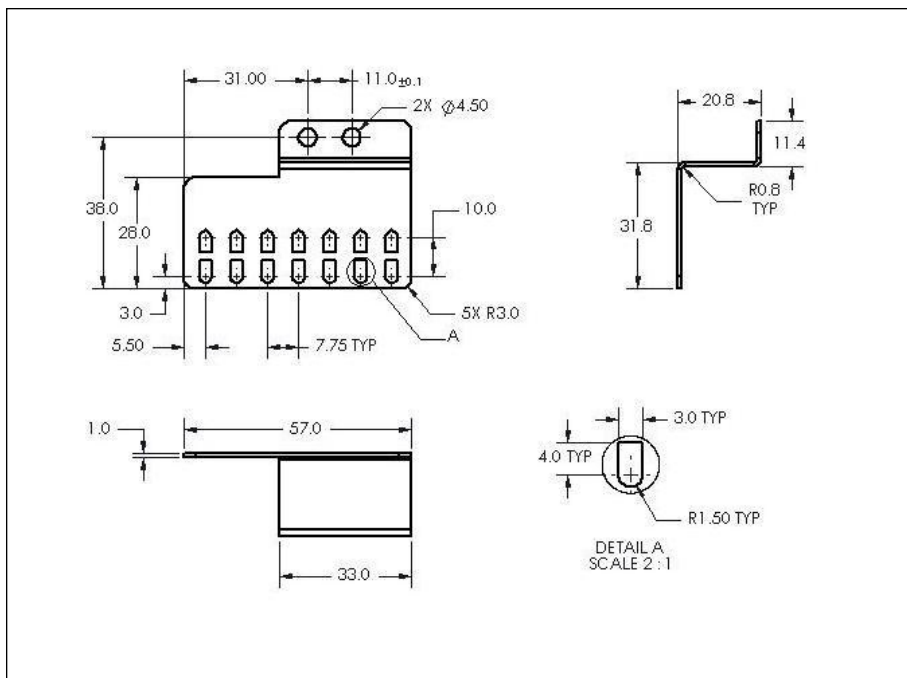

5.2.2 AKD-z-00307, AKD-z-00607, and AKD-z-01207 shield plate

This shield plate (Item number 153-254001-00) is included for use with AKD-z-00307, AKD-z-00607, and AKD-z-01207 drives.

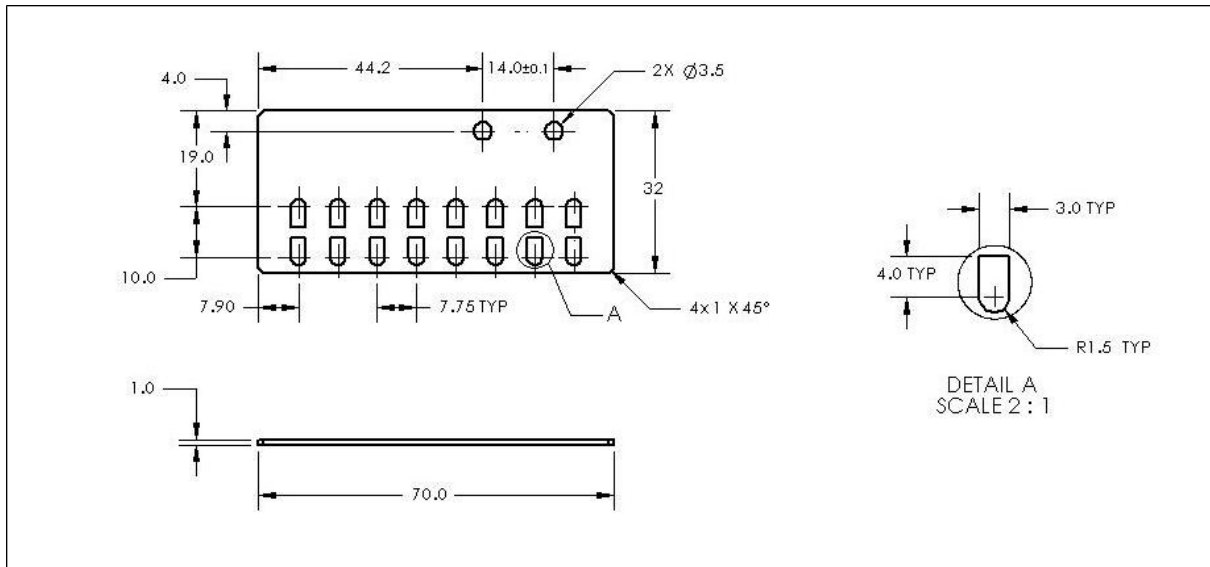

5.2.3 AKD-z-02407 shield plate

This shield plate (Item 153-255000-02) is included for use with the AKD-z-02407 drive.

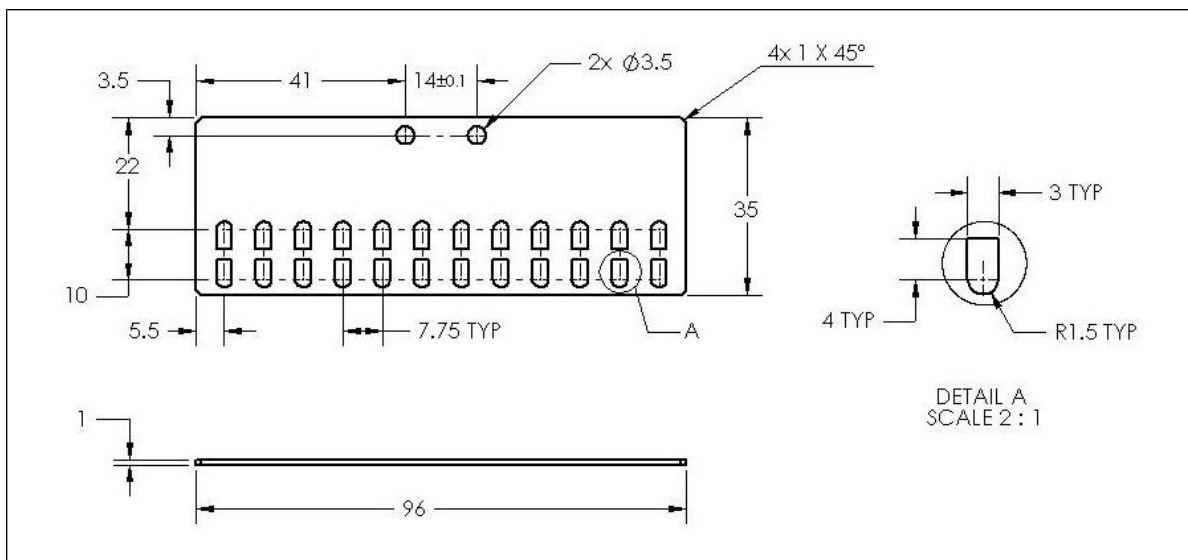

5.3 AKD and S701 to S724 Shield Clamps (purchased separately)



S701 to 724 and AKD drives feature slots on the front panel for connecting additional shield clamps.

Recommended shield clamp:

Manufacturer	Item	Tension range
Phoenix Contact	SK14	6-13 mm

5.4 S748 to S772 Shield Clamps (purchased separately)



The shroud supplied with S748 to S772 drives features slots for the connection of additional shield clamps. The clamps are included with the drive.

Recommend shield clamps:

Manufacturer	Item	Tension range
OBO (Bettermann)	BBS-Schelle Typ 2056	16-22 mm
OBO (Bettermann)	BBS-Schelle Typ 2056	28-34 mm

5.5 External Shielding Busbar (purchased separately)



In special cases, the cable shields can be routed to an additional busbar via shield clamps. The following shield clamp is recommended:

Manufacturer	Item	Tension range
Weidmüller	KLBÜ	6-13 mm

A possible scenario for setting up a busbar for the above shield clamps is described below.

- Cut a busbar of the required length from a brass rail (cross-section 10 x 3 mm) and drill holes in it as indicated. All shield clamps required must fit between the drill holes.

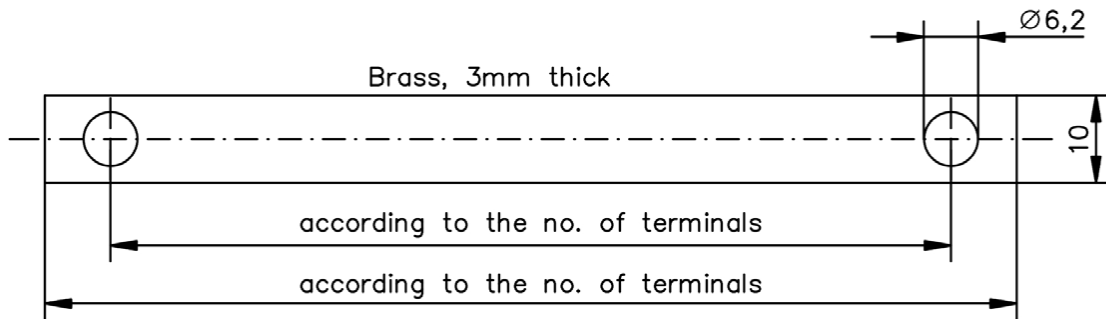

- Squeeze together the coil spring and the supporting plate and push the busbar through the opening in the holder.

CAUTION Risk of injury is present due to the spring force of the coil spring. Use pincers.

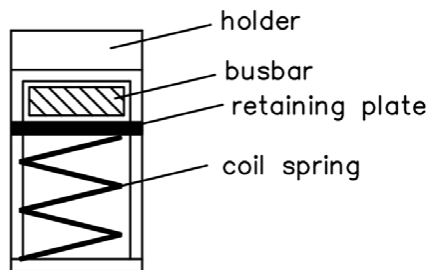

- Mount the busbar with the shield clamps fitted on the assembly plate. Use either metal spacer bushes or screws with nuts and accessories to maintain a spacing of 50 mm. Earth the busbar using a single conductor with a cross-section of at least 2.5 mm².

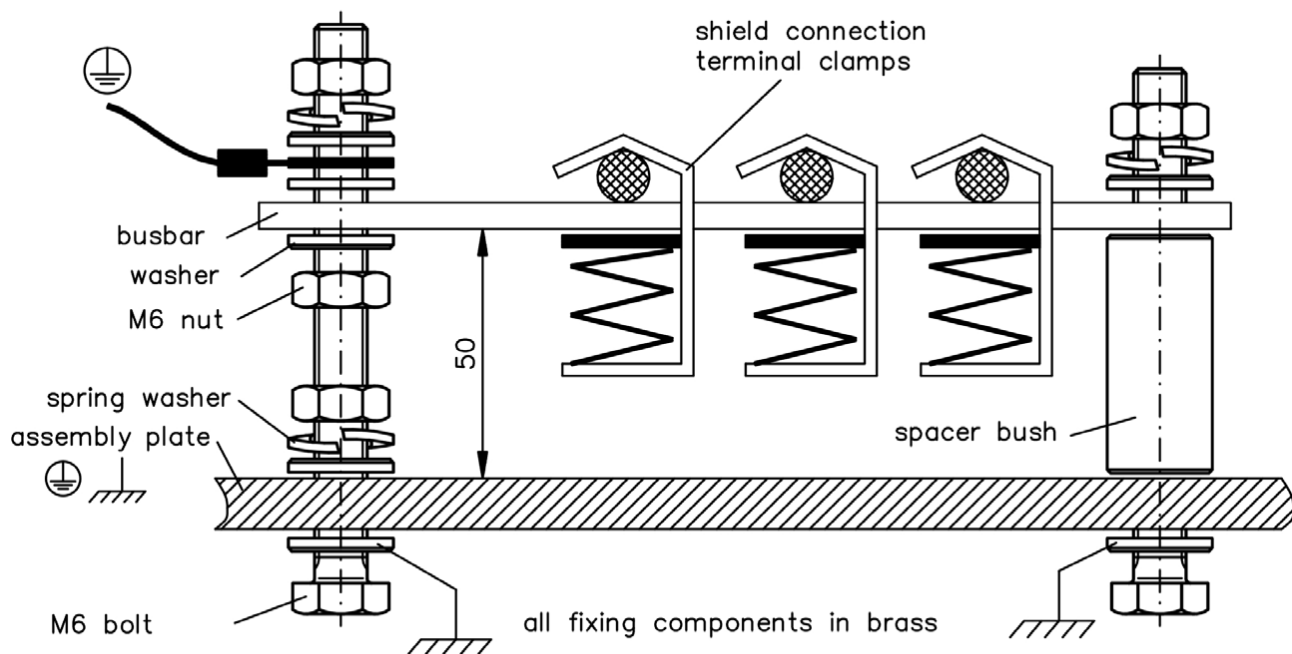

- Strip the external cable sheath to a length of approx. 30 mm, taking care not to damage the braided shield. Push the shield clamp up and route the cable to it via the busbar.

NOTICE

Make sure good contact exists between the shield clamp and the braided shield.

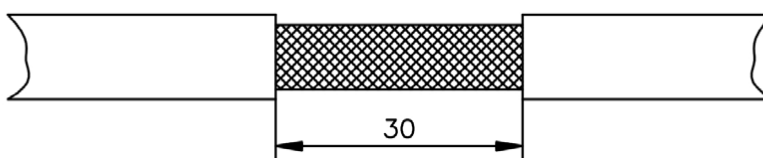

6 Mains Chokes

In special cases, if mains voltage is more than 3% asymmetrical, then the S748/772 drives must be used with a mains choke. Without this choke, an unfavorable combination of mains impedance and DC bus capacitance can result in an unloaded DC bus voltage of up to 800 V.

To reduce EMC, the chokes should be mounted isolated from the cabinet. Single conductors can be used for wiring; shielded cables are not required.

The purpose of mains choke is as follows:

- Prevents overloading of the semiconductors in the event of a rapid current rise during commutation.
- Prevents voltage dips in the mains voltage caused by commutation.
- Reduces current ripple in the DC link, which increases the service life of the DC link capacitors.

NOTICE

Several drives can be connected to one mains choke; the rated current of the mains choke must be greater than or at least equal to the total current of the connected drives.

6.1 Safety instructions

⚠WARNING

Power terminals can conduct hazardous voltage up to 10 minutes after the mains voltage has been disconnected. Before starting work on power terminals, check that the phase-to-earth and phase-to-phase voltages have de-energised.

⚠WARNING

Due to the high earth leakage currents induced by the system, you should observe the requirements of EN 61800-5-1 (which is fixed installation, $\geq 10 \text{ mm}^2$ or double protective earth) when carrying out mounting and installation work.

⚠CAUTION

You must read the instruction manuals for the drive/motor you are using in your application and observe the safety instructions they contain before starting mounting/installation work.

⚠CAUTION

This manual is only valid in conjunction with the instruction manuals for the drive and motor you are using in your application.

NOTICE

A connection diagram appears in the drive instruction manual.

6.2 Type assignment

Drive	Mains Choke
S748 (with asymmetrical mains >3% only)	2% uk
S772 (with asymmetrical mains >3% only)	2% uk
S701 to 724	Not required

6.3 Order codes

Item		uk	Order codes	Comments
Mains choke 3L0,2-50-2	(0.24 mH, 50A)	2%	DE-201476	Can be used for S748/772 in case of asymmetric mains
Mains choke 3L0, 2-75-2	(0.20 mH, 75 A)	2%	DE-201477	Can be used for S748/772 in case of asymmetric mains

6.4 Mains choke 3L

Mains choke 3L is shown in the photograph and drawings below.

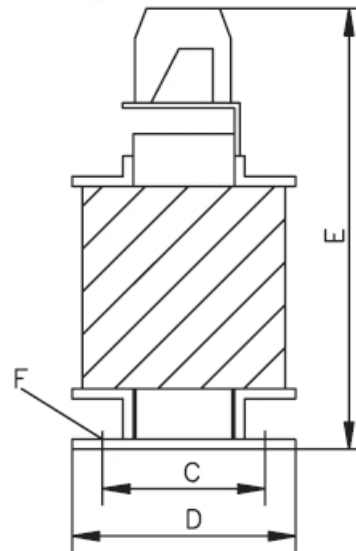
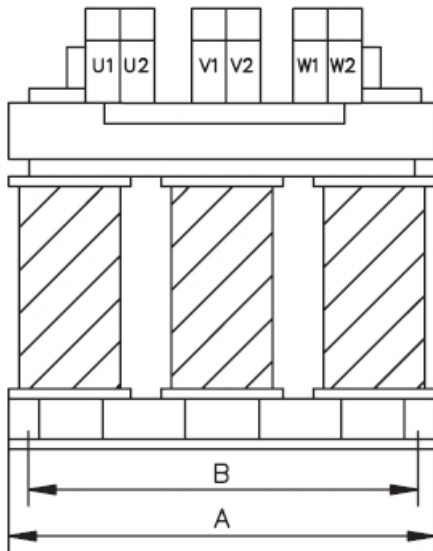
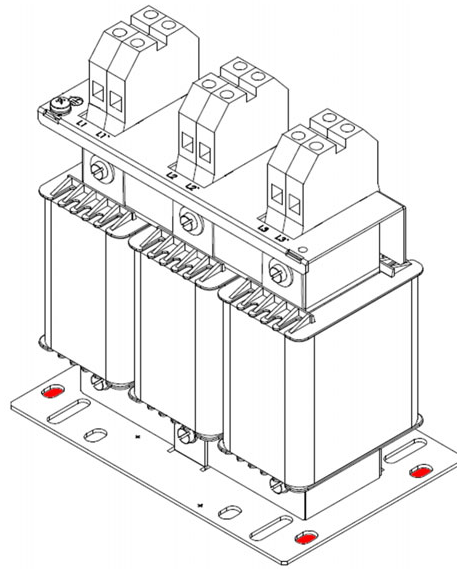
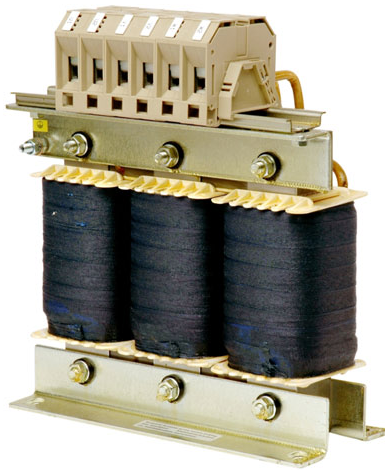

Technical Data

Type	Inductivity [mH]	Nominal Current [A]	uk [%]	A [mm]	B [mm]	C [mm]	D [mm]	E [mm]	F [mm]	Terminals [mm ²]	Weight [kg]
3L 0, 24-50-2	0.24	50	2	152.5	114.3	88.9	101.5	163	6.5	10	5.9
3L 0, 2-75-2	0.20	75	2	185	170	77	122	220	8x12	35	9.9

7 Mains Filters

AKD-P00306 to 02406 drives require an external mains filter. All other drives feature built-in mains filters (see the relevant instruction manual). In order for the mains filters to function properly, the permissible throughput rating of the mains filters must not be exceeded even on peak loading of the drives with I_{peak} .

Maximum available throughput rating of the mains filter (F):

$$P_{max F} = \sqrt{3} \cdot U_N \cdot I_{NF}$$

Maximum power consumption of the drive:

$$P_{max V} = g \cdot \sqrt{3} \cdot U_N \cdot \sum_i I_{peakVi}$$

Maximum power consumption of the motors (M):

$$P_{max M} = g \cdot \sum_i k_{EI} \cdot \frac{n_i}{1000} \cdot I_{peakVi} \cdot \sqrt{\frac{3}{2}}$$

The rated current I_{NF} of the mains filter in a system with i axes must be:

$$I_{NF} \leq 2 \cdot \sum_i I_{NVi}$$

(total of twice the rated currents of the amplifiers) and, more precisely,

$$I_{NF} \leq \frac{P_{max M}}{\sqrt{3} \cdot U_N}$$

(typical maximum single value of the amplifier peak currents)

In many cases, you can use the next smallest filter in the event of a low coincidence factor g or low load.

7.1 Safety instructions

CAUTION You must read the instructions manual for the drive/motor you are using in your application and observe the safety instructions they contain before commencing mounting/installation work. This manual is only valid in conjunction with the instructions manual for the drive and motor you are using in your application.

WARNING Power terminals are capable of conducting hazardous voltage up to 10 minutes after the mains voltage has been disconnected. Before starting work on power terminals, check that the phase-to-earth and phase-to-phase voltages have de-energized.

WARNING Due to the high earth leakage currents induced by the system, you should observe the requirements of EN 61800-5-1 (e.g. fixed installation, $\geq 10 \text{ mm}^2$ or double protective earth) when carrying out mounting and installation work. A connection diagram appears in the drive installation manual.

7.2 Type assignment

Drive	Mains filter
AKD-P00306 to 02406 (120 to 240V)	FN-type Shaffner filters recommended
AKD-P00307 to 02407 (240 to 480V)	Not required
S700	Not required

7.3 Order codes

Drive	Schaffner Filter	Description
AKD-x-00306	FN2320Y-10-06	Mains Filter - single phase, 230 V AC, CE*, UL
AKD-x-00606	FN2320Y-10-06	Mains Filter - single phase, 230 V AC, CE*, UL
AKD-x-01206	FN2070-12-06	Mains Filter - single phase, 230 V AC, CE*, UL
AKD-x-00306	FN3258-7-45	Mains Filter - three phases, 480 V AC, CE*, UL
AKD-x-00606	FN3258-16-45	Mains Filter - three phases, 480 V AC, CE*, UL
AKD-x-01206	FN3258-16-45	Mains Filter - three phases, 480 V AC, CE*, UL
AKD-x-02406	FN3258-30-47	Mains Filter - three phases, 480 V AC, CE*, UL

* No EC directive matches mains filters. You can use these filters in Europe, because they are manufactured according to harmonized standards concerning creeping and voltage distances.

7.4 Mains filters FN2320Y-10-06 and FN2070-12-06



Observe the safety instructions.
For single-phase operation only.

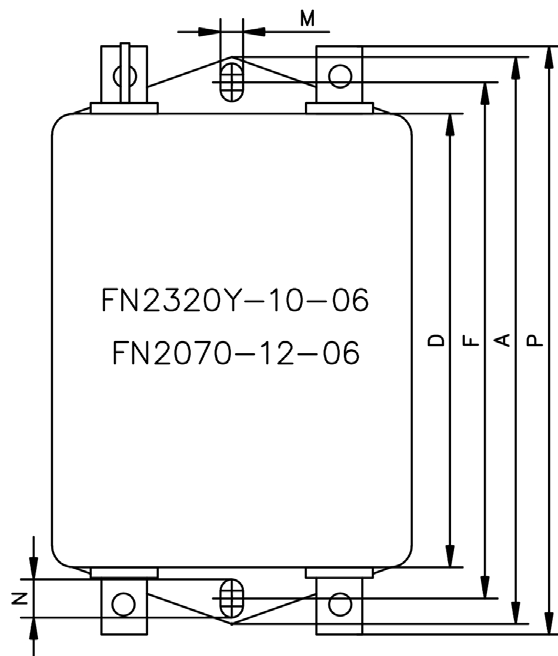

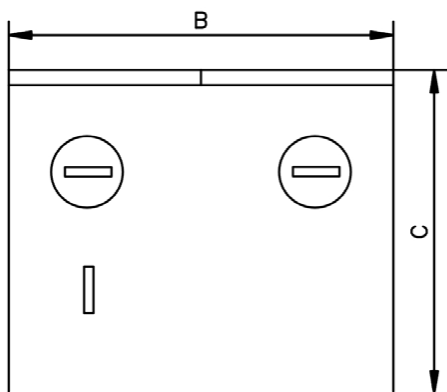

Technical Data

Type	Nominal Current [A]*	A [mm]	B [mm]	C [mm]	D [mm]	F [mm]	M [mm]	N [mm]	P [mm]	Weight [kg]	Connection
FN2320Y-10-06	10	85	49	40.3	54	75	5.3	6.3	87	0.29	Fast-on
FN2070-12-06	12	156	57.5	45.4	130.5	143	5.3	6	156	0.73	Fast-on

* at 40°C environment temperature

7.5 Mains filters FN3258-7-45, FN3258-16-45, and FN3258-30-47



Observe the safety instructions.
For three-phase operation only.

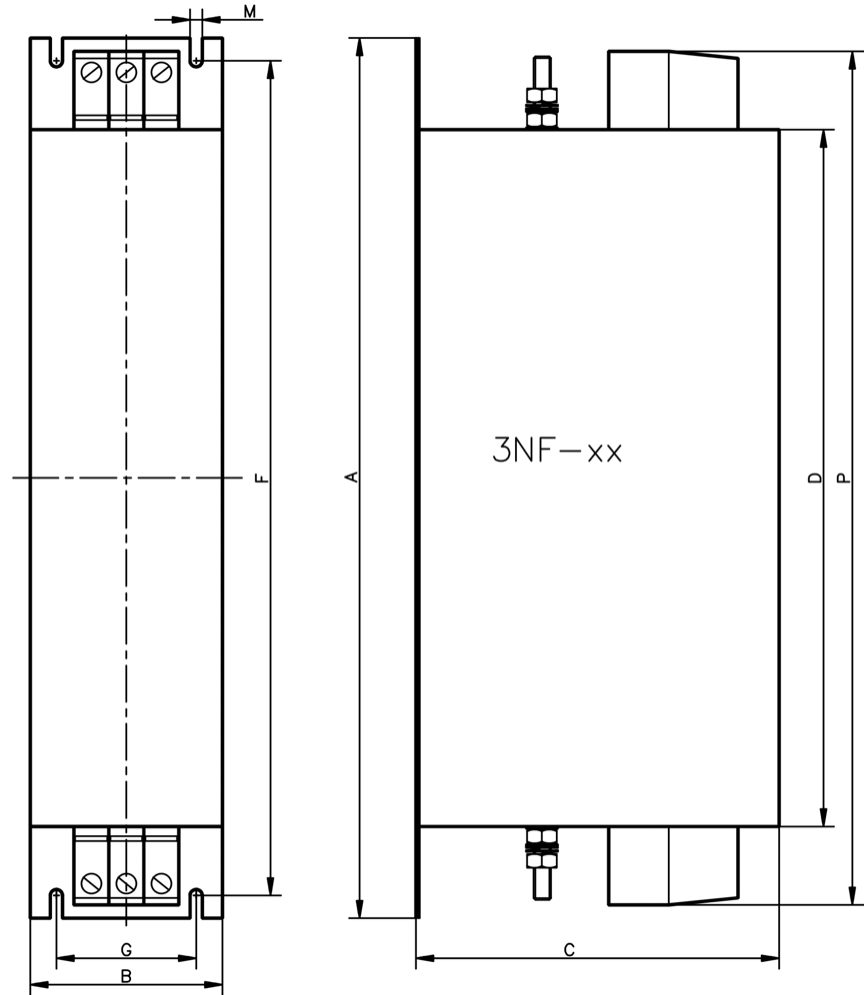

Technical Data

Type	Nom-inal Cur-rent*	A [m-m]	B [m-m]	C [m-m]	D [m-m]	F [m-m]	G [m-m]	M [m-m]	P [m-m]	Weight [kg]	Terminals	PE Bolt
FN3258-7-45	7 A	190	40	70	160	180	20	4.5	180	0.5	4 mm ² , 0.7 to 0.8 Nm	M5, 2.2Nm
FN3258-16-45	16 A	250	45	70	220	235	25	5.4	240	0.8		
FN3258-30-47	30 A	270	50	85	240	255	30	5.4	260	1.2	10 mm ² , 1.9 to 2.2 Nm	

* at 50°C environment temperature

8 Capacitor Modules

KCM modules (KOLLMORGEN Capacitor Modules) absorb energy generated by the motor when it is operating in generator mode. Normally, this energy is dissipated as waste via brake resistors. KCM modules, however, feed the energy they have stored back into the DC Bus link as and when it is required.

KCM-S	Saves energy: The energy stored in the capacitor module during regenerative braking is available the next time acceleration happens. The module's inception voltage is calculated automatically during the first load cycles.
KCM-P	Power in spite of power failure: If the power supply fails, the module provides the drive with the stored energy that is required to bring the drive to a standstill in a controlled manner (this only applies to the power supply voltage; battery-back the 24 V supply separately).
KCM-E	Expansion module for both applications. Expansion modules are available in two capacitance classes.

8.1 Important Notes

⚠ DANGER DC Bus link terminals in servo systems carry high DC voltage of up to 900 V. Touching the terminals while they are carrying voltage is extremely dangerous. Switch off (disconnect) the line voltage. You must only work on the connections when the system is disconnected.

It can take over an hour for the modules to self-discharge. Check the state of charge with a measuring device that is suitable for a DC voltage of up to 1,000 V. When measuring a voltage of over 40 V between the DC+/DC- terminals or to ground, discharge the modules as described in the KCM Instructions Manual.

NOTICE You must read the instructions manual for the drive / servomotor you are using in your application and observe the safety instructions they contain before commencing mounting/installation work.

Wiring diagram and more important notes concerning wiring can be found in the KCM instructions manual and in the instructions manual of the used drive.

8.2 Order codes

Type/Order Code	Remarks
KCM-S200-0000	Energy Saving Module, 1.6 kW
KCM-P200-0000	Power Module, 2 kW
KCM-E200-0000	Expansion Module 2 kW
KCM-E400-0000	Expansion Module 4 kW

8.3 Technical Data

Type	Storage Capacity [Ws]	Rated supply voltage [V=]	Peak supply voltage [V=]	Power [kW]	Protection Class	Inception voltage [V=]	Weight' [kg]
KCM-S200	1600	max 850 VDC	max 950 VDC (30s in 6min)	18	IP20	calculated	6,9
KCM-P200	2000					470 VDC	6,9
KCM-E200	2000					-	4,1
KCM-E400	4000					-	6,2

8.4 External regen resistor BAFP(U)



Observe the instructions in chapter "Important Notes " (→ p. 28) and in the instruction manual of the drive.

Permissible assembly type: Vertical, ground connections at the bottom. Other assembly positions are not permitted. Observe the required free space to next device. Ensure there is unobstructed convection for cooling purposes.

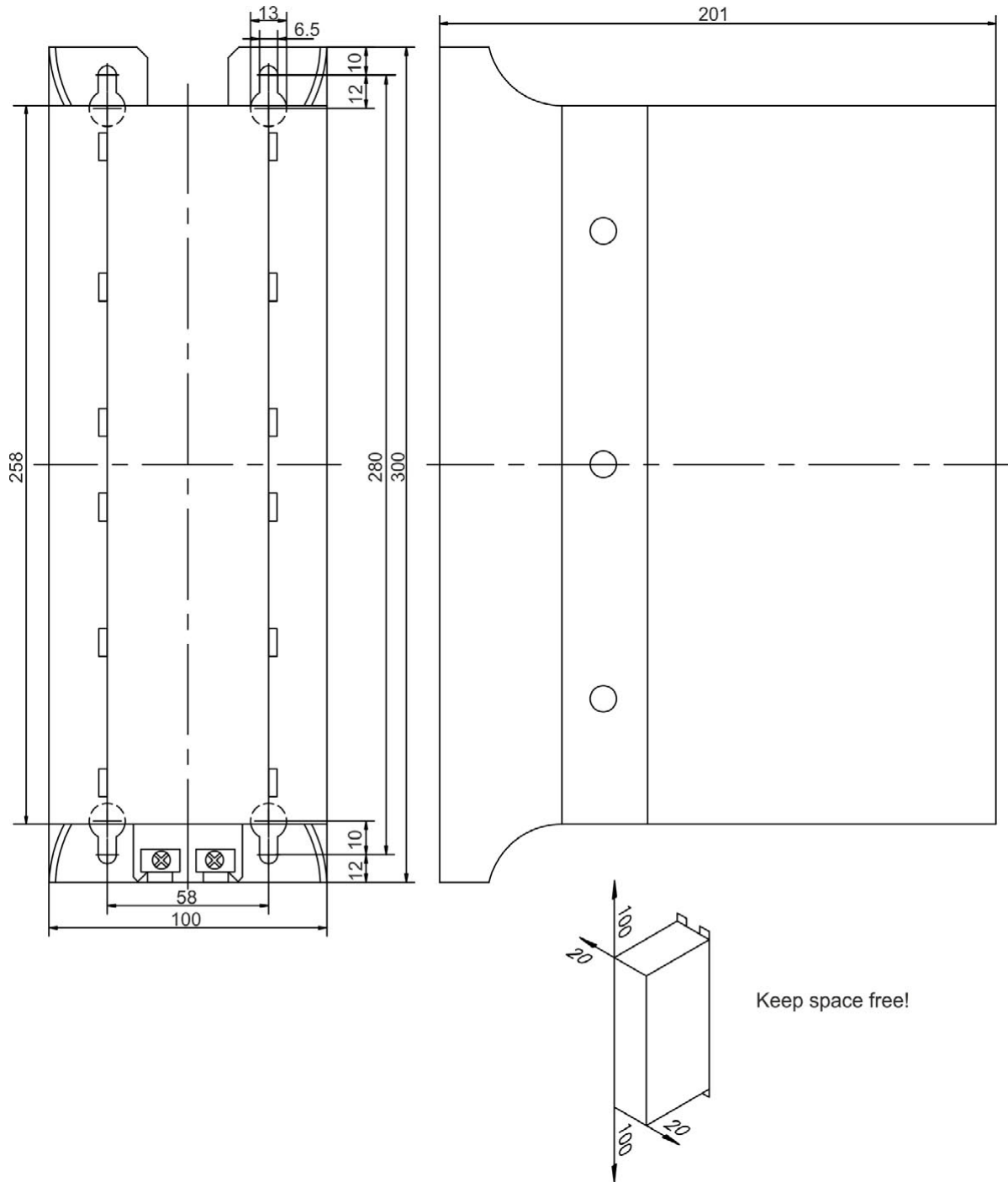

Keep space free!

9 Brake/Regeneration Resistors

During braking with the aid of the motor, energy is fed back into the drive. This energy is dissipated as heat in the regeneration resistor (referred to as a brake resistor when used with an S700 drive). The regen resistor is switched on by the brake circuit. Different resistance values must be used depending on the drive. All regen resistors meet the requirements of CE directives and are UL-registered. Regen resistor requirements for Kollmorgen servo systems can be calculated using the Motioneering sizing and selection tool available here:

http://www.kollmorgen.com/website/com/eng/support/design_tools/motioneering.php.

9.1 Safety Instructions

CAUTION

- You must read the instruction manuals for the drive and motor that you are using in your application and observe the safety instructions they contain before starting mounting/installation work.
- This manual is only valid in conjunction with the instruction manuals for the drive and motor you are using in your application.
- Danger of burn. Mount only in switchgear cabinets, observe installation clearances, provide the requisite conditions for unobstructed convection for cooling. As Regen resistors can heat up to temperatures in excess of 250°C, use temperature-resistant components in the vicinity of the resistor.
- Observe allowed mounting positions (see dimension drawings). The connection terminals must never be in the diversion area of hot air.
- In case of insufficient cooling or false mounting the resistor or the surrounding devices could be overheated or damaged.
- A connection diagram appears in the drive's instructions manual.

NOTICE

For best results, the following conditions must be provided for regen resistors:

- Unobstructed cooling air
- Unobstructed diversion of warmed air
- Rated data with maximum ambient temperature 40°C, in case of ambient temperature higher than 40°C, power must be reduced by 4% per 10K temperature rise.

9.2 Type assignment

Drive	Regen resistor	Resistance/Ohm
AKD-P00306	BAFP(U)/BAR(U)/BAS(U)	33
AKD-P00606	BAFP(U)/BAR(U)/BAS(U)	33
AKD-P01206	BAFP(U)/BAR(U)/BAS(U)	33
AKD-P02406	BAR(U)/BAS(U)	15
AKD-P00307	BAR(U)/BAS(U)	33
AKD-P00607	BAR(U)/BAS(U)	33
AKD-P01207	BAR(U)/BAS(U)	33
AKD-P02407	BAR(U)/BAS(U)	23
S701 to 712	BAR(U)	33
S724	BAR(U)/BAS(U)	23

Drive	Regen resistor	Resistance/Ohm
S748	BAS(U)	15
S772	BAS(U)	10

9.3 Order codes

Description	Drive	Resistance []	Rated Power [W]	Max. Power [W]	Order code
Regen resistor BAS(U) 2000-10	S772	10	2000	3200	BAS-2000-10
Regen resistor BAS(U) 3000-10		10	3000	4800	BAS-3000-10
Regen resistor BAS(U) 6000-10		10	6000	9600	BAS-6000-10
Regen resistor BAR(U) 500-15	AKD-P02406, S748	15	500	800	BAR-500-15
Regen resistor BAR(U) 1000-15		15	1000	1600	BAR-1000-15
Regen resistor BAS(U) 2000-15		15	2000	3200	BAS-2000-15
Regen resistor BAS(U) 3000-15		15	3000	4800	BAS-3000-15
Regen resistor BAS(U) 6000-15		15	6000	9600	BAS-6000-15
Regen resistor BAR(U) 600-23		AKD-P02407, S724	23	600	960
Regen resistor BAR(U) 1000-23	23		1000	1600	BAR-1000-23
Regen resistor BAS(U) 2000-23	23		2000	3200	BAS-2000-23
Regen resistor BAS(U) 3000-23	23		3000	4800	BAS-3000-23
Regen resistor BAS(U) 4000-23	23		4000	6400	BAS-4000-23
Regen resistor BAFP(U) 100-33	AKD-P003 to 12, S701 to 712		33	100	160
Regen resistor BAFP(U) 200-33		33	200	320	BAFP-200-33
Regen resistor BAR(U) 250-33		33	250	400	BAR-250-33
Regen resistor BAR(U) 500-33		33	500	800	BAR-500-33
Regen resistor BAR(U) 1500-33		33	1500	2400	BAR-1500-33
Regen resistor BAS(U) 3000-33		33	3000	4800	BAS-3000-33

9.4 External regen resistor BAFP(U)



Protection class: IP40



- Surface temperature can exceed 250°C.
- Make sure that the necessary space is kept clear.
- Do not mount on combustible surfaces.

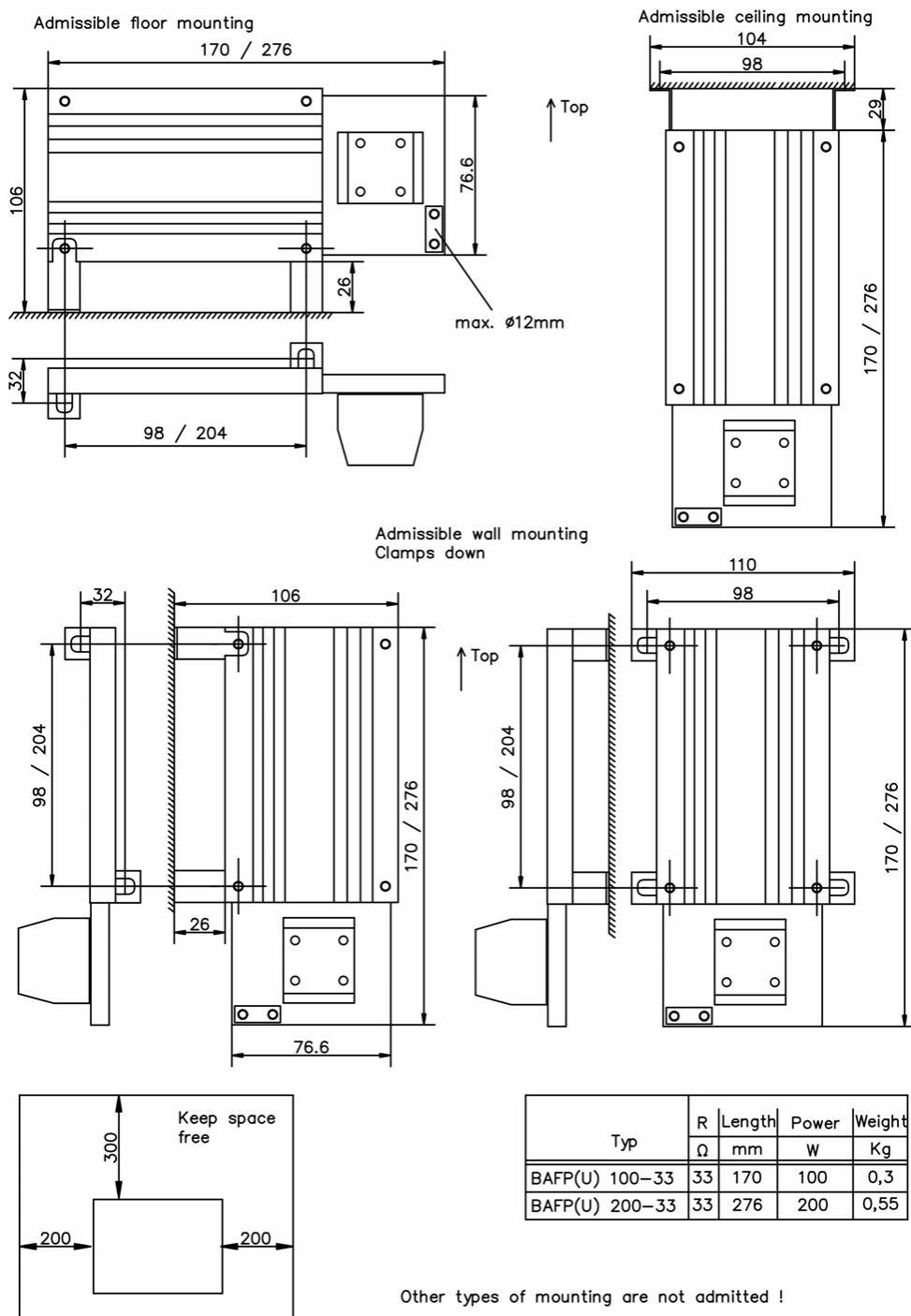

9.5 External regen resistor BAR(U)

Protection class: IP20



- Surface temperature can exceed 250°C.
- Make sure that the necessary space is kept clear.
- Do not mount on combustible surfaces.

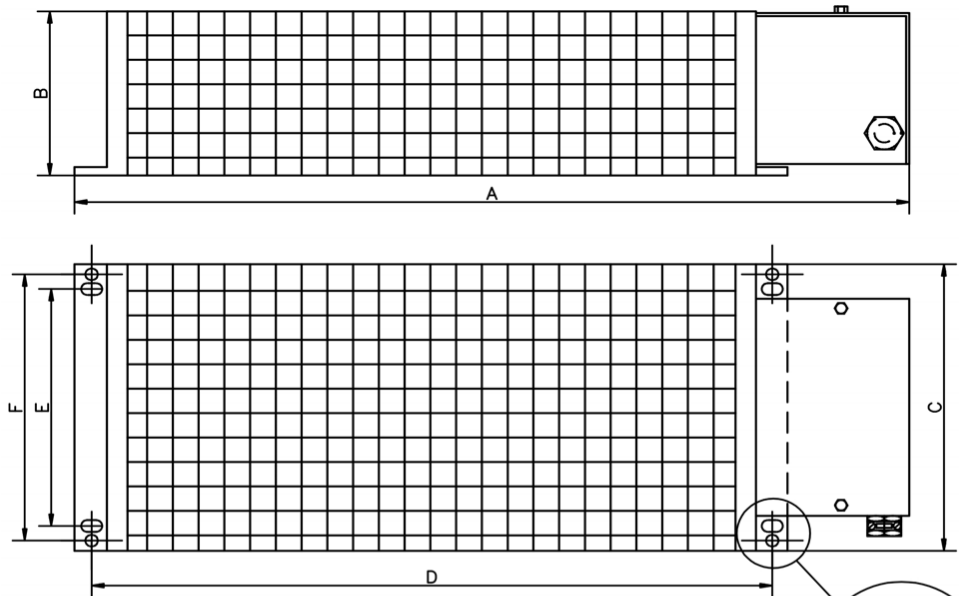

Type	R	Power	A	B	C	D	E	F	weight
	Ω	W	mm	mm	mm	mm	mm	mm	Kg
BAR(U) 500	15	500	549	120	92	430	64	80	3
BAR(U) 1000	15	1000	749	120	92	630	64	80	4
BAR(U) 600	23	600	549	120	92	430	64	80	3
BAR(U) 1000	23	1000	749	120	92	630	64	80	4
BAR(U) 250	33	250	349	120	92	230	64	80	2
BAR(U) 500	33	500	549	120	92	430	64	80	3
BAR(U) 1500	33	1500	649	120	185	530	-	150	5,8
BAR(U) 300	66	300	349	120	92	226	64	80	1,5
BAR(U) 600	66	600	549	120	92	426	64	80	2,3
BAR(U) 1000	66	1000	749	120	92	626	64	80	3,4
BAR(U) 300	91	300	349	120	92	226	64	80	1,5
BAR(U) 600	91	600	549	120	92	426	64	80	2,3
BAR(U) 1000	91	1000	749	120	92	626	64	80	3,4

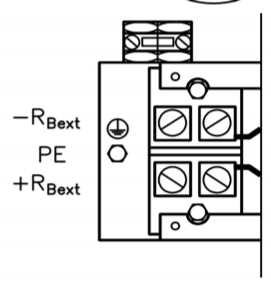

±10%, Temperaturdrift ca. 1%
Kalt ca. +8%, 320°C ca. -7%

Admissible floor mounting

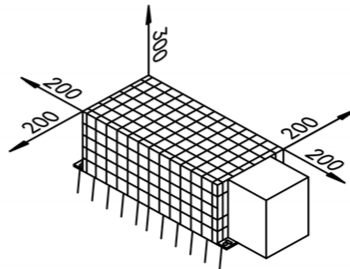

Admissible wall mounting
Clamps down

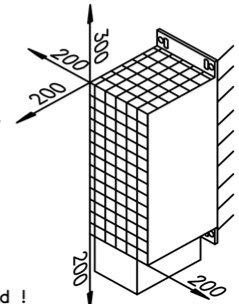

Other types of mounting are not admitted !

9.6 External regen resistor BAS(U)



Protection class: IP20



- Surface temperature can exceed 250°C.
- Make sure that the necessary space is kept clear.
- Do not mount on combustible surfaces.

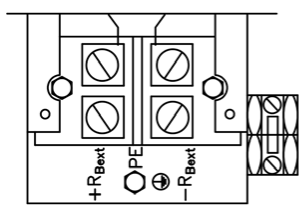
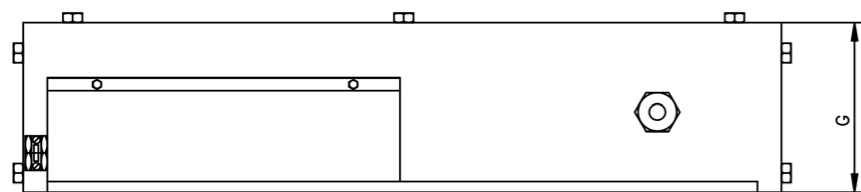
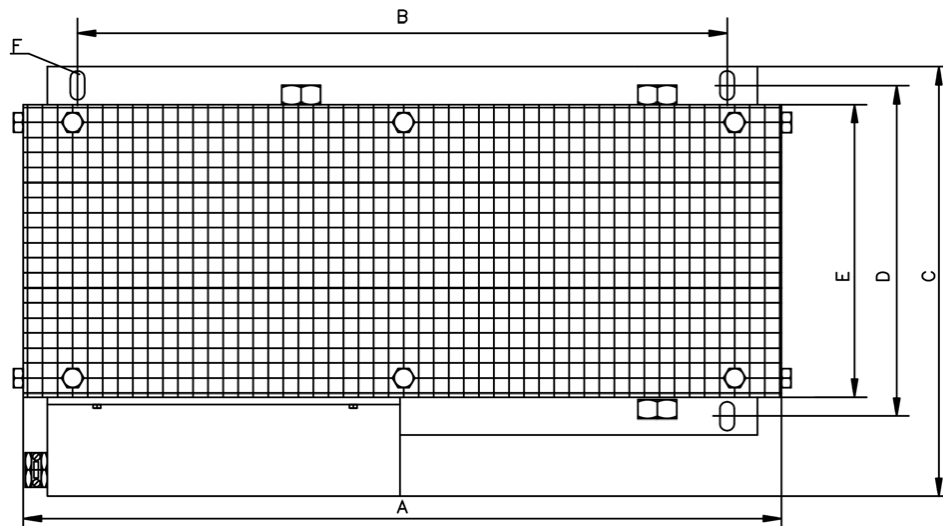

Admissible floor mounting

Admissible wall mounting
Clamps down

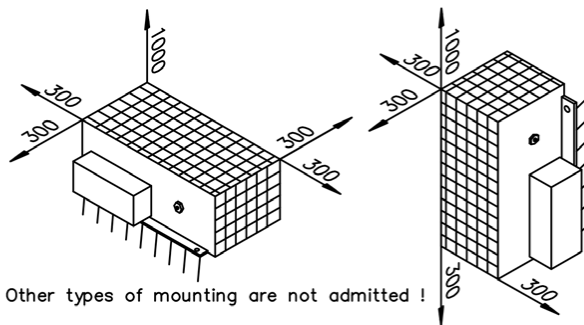

±10%, Temperaturdrift ca. 1%
Kalt ca. +8%, 320°C ca. -7%

	R	Rated power	A	B	C	D	E	F	G	weight
	Ω	W	mm	mm	mm	mm	mm	mm	mm	Kg
BAS(U)2000-10	10	2000	490	380	255	170	150	∅10,5	260	7
BAS(U)3000-10	10	3000	490	380	355	270	250	∅10,5	260	8
BAS(U)6000-10	10	6000	490	380	455	370	350	∅10,5	260	11
BAS(U)2000-15	15	2000	490	380	255	170	150	∅10,5	260	7
BAS(U)3000-15	15	3000	490	380	355	270	250	∅10,5	260	8
BAS(U)6000-15	15	6000	490	380	455	370	350	∅10,5	260	11
BAS(U)2000-23	23	2000	490	380	255	170	150	∅10,5	260	7
BAS(U)3000-23	23	3000	490	380	355	270	250	∅10,5	260	8
BAS(U)4000-23	23	4000	490	380	355	270	250	∅10,5	260	9
BAS(U)3000-33	33	3000	490	380	355	270	250	∅10,5	260	8

10 Motor Chokes

10.1 Shielded motor cables

For electromagnetic compatibility, the motor must be supplied with power using a shielded cable. The structure of a cable with 100% shielding and the capacity equivalent circuit diagram (to earth) are shown below.

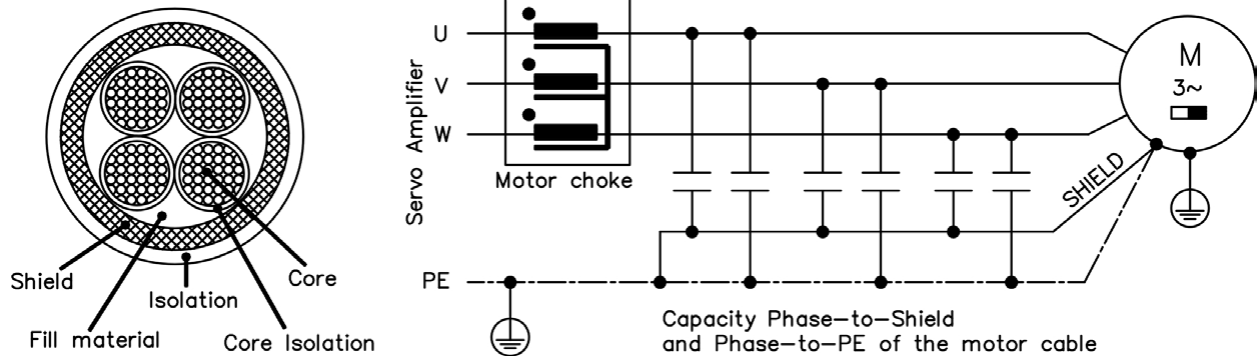

Why use motor chokes?

- To compensate for high capacitive charge/discharge currents typical of shielded motor cables approximately 25 m and longer.
- To reduce current alternation noise in the motor.
- To reduce current ripple in the motor.

The digital drives' high switching frequencies and steep switching edges give rise to the transfer of capacitive currents to the shield by the three phases (U, V, W). These currents flow from the shield to earth. Depending on the cable length and cable capacity (determined by design), this can lead to the generation of shield currents with peak values of up to 20 A.

These shield currents place a load on the drives and motor and, on large systems, lead to shifts in potential which can damage other components. This effect is evident in particular on systems with multiple amplifiers operating in parallel on the same mains filter. The motor chokes slow down the rate of rise of the motor current (reduce edge steepness), thereby reducing the current transferred to the shield.

Why is the cross-section of the motor cable important?

Motor cables longer than 50 m with a small cross-section (such as 4 x 1.0 mm²) and therefore a higher equivalent resistance are able to reduce the oscillation tendency of the LCR oscillating circuit (amplifier/choke/ cable/motor). This cross-section can also be advantageous for cable lengths shorter than 50 m if the cable capacity and motor inductance are very high. However, the current loading of the cable must always be within the limits specified by EN 60204.

10.2 Safety Instructions

CAUTION

- Before starting mounting/installation work, you must read and observe the instruction manuals and the safety instructions that they contain for the drive and motor that you are using in your application.
- This manual is only valid in conjunction with the instruction manuals for the drive and motor you are using in your application.
- Mount the motor choke on a conductive earthed assembly plate in the switch-gear cabinet.
- The choke can become hot during operation (rising to temperatures in excess of 80°C). Therefore, you should make sure that the choke is mounted a sufficient distance away from neighboring components.
- Provide the requisite conditions for unobstructed convection to cool the choke.
- A connection diagram appears in the drive instructions manual.
- If the motor cable is longer than 25m, then the motor choke is wired into the cable close to the amplifier. When laying the motor cable, allow about 400 mm for the connection to the choke.

10.3 Type assignment

Drive*	Motor choke	Approvals	Condition
AKD-P003x to AKD-P006x	3YLN-06	CE, UL	Motor cable > 25m
AKD-P012x	3YLN-14	CE, UL	Motor cable > 25m
AKD-P024x	3YLN-24	CE, UL	Motor cable > 25m
S701 to 724	3YLN-xx	CE, UL	Motor cable > 25m
S748/772		Not required	

*AKD part numbers indicate continuous current rating (-003 is 3 A, -012 is 12 A, etc.).

10.4 Motor choke 3YLN-xx

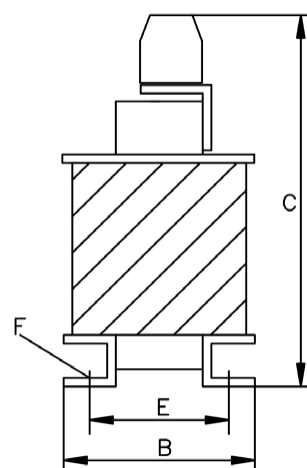
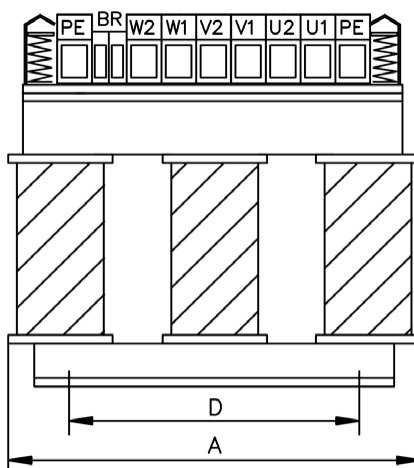
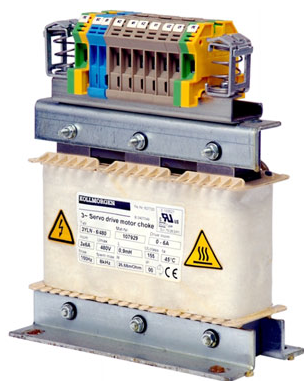

Technical Data

Rated Data	Symbol	Units	3YLN-06	3YLN-14	3YLN-20	3YLN-24
Rated current	I _{0rms}	A	6	14	20	24
Rated voltage	U _{nom}	V	480			
Rated frequency	f _{nom}	Hz		0 to 150		
Max. frequency	f _{max}	kHz	8			
Inductivity	L	μH	900	900	450	450
Power loss	P	W	12	19.4	22.3	23.2
Protection class	-	-	IP00			
Temperature class	-	-	F			
Operation class	-	-	S1			
Weight	G	kg	4.5	10	10	10
Cable diameter (Shield clamp)	-	mm	4 to 13.5			
Wiring cross section max. (Terminals)	-	mm ²	10	16	16	16
Width	A	mm	155	190	190	190
Depth	B	mm	90	125	125	125
Height	C	mm	195	230	230	230
Mounting hole distance	D	mm	130	170	170	170
Mounting hole distance	E	mm	56.5	78	78	78
Mounting screws	F	-	4xM6	4xM6	4xM6	4xM6

11 Cables

11.1 PC connection

The AKD drive is connected to a PC or to a switch/hub by a standard net cable with RJ45 connectors.
The S700 drive series is connected to a PC using a serial RS232-SubD9 cable.

11.2 Kollmorgen Ethernet Cables

PUR jacketed CAT5e cables, pre-terminated with RJ45 connectors.

Article	Description	Order code
Ethernet cable	0.17 meter pre-terminated patch cable	ENCP-0017-000
Ethernet cable	0.26 meter pre-terminated patch cable	ENCP-0026-000
Ethernet cable	0.50 meter pre-terminated patch cable	ENCP-0050-000
Ethernet cable	1 meter pre-terminated patch cable	ENCP-0100-000
Ethernet cable	2 meter pre-terminated patch cable	ENCP-0200-000
Ethernet cable	3 meter pre-terminated patch cable	ENCP-0300-000
Ethernet cable	4 meter pre-terminated patch cable	ENCP-0400-000
Ethernet cable	5 meter pre-terminated patch cable	ENCP-0500-000
Ethernet cable	10 meter pre-terminated patch cable	ENCP-1000-000
Ethernet cable	Unterminated cable per 10 meter increment (min 30 meters)	ENCU-xxxx-000
Ethernet cable	Connector kit for ENCU-xxxx-000 unterminated cable (one termination per kit)	ENCU-KIT-000

Technical Data:

ENCP-xxxx-xxx (Kollmorgen Ethernet Cables)	
Cross-section	4 x 2 x AWG26/7 ... 4 x 2 x 0.128 mm ²
Cable sheath material	PUR
Color	Green (RAL 6018)
Line configuration	SF/UTP
Diameter	sheath: typ. 5.9 mm ± 0.2 mm
Bending radius	> 5 x diameter
Category/class	CAT5e, class D
Operating/installation temperature	-40... +75 °C/-10 ... +60 °C
Insertion cycles	min. 750

11.3 CANopen Bus Cables for AKD

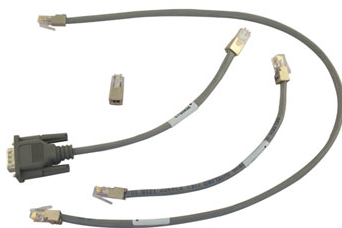

Configured CANopen bus cables are available for AKD. See CANopen Bus Cable Specifications (pg 45) for specifications.

Item	Length	AKD Order Code
CANopen bus cable	0.15 m	P-AKD-CAN-RJ-0-15
CANopen bus cable	0.5 m	P-AKD-CAN-RJ-0-50
CANopen bus cable	3.0 m	P-AKD-CAN-RJ-3-00

The CANopen bus termination plug is required for bus termination of the last AKD drive connected to the CANopen bus. To connect an AKD drive to a CANopen device with a SubD9 connector, use the CAN RJ12-SubD9.

Item	AKD Order Code
CANopen bus termination plug	P-AKD-CAN-TERM
CAN RJ12-SubD9 adapter	P-AKD-CAN-9d-0-15

According to ISO 11898, you should use a bus cable with a characteristic impedance of 120 Ω. The usable cable length depends on the transmission rate. The values that have been measured can be taken as a guide, but they should not be interpreted as limits.

Cable length, depending on the transmission rate:

Transmission rate/kbps:	1000	500	250
Maximum cable length/m:	20	70	115

11.4 Motor Power and Feedback Cables

These cables differ in how they are connected to the drive, due to the varying requirements for minimum code distances, different shielding concepts depending on rated voltage, and current load. The following pre-assembled, ready-to-use cables meet the requirements of relevant CE and UL standards. See Motor Power Cable Specifications (pg 48) and Motor Feedback Cable Specifications (pg 54) for engineering details on all cables.



Value Line Cables



Flex Line Cables



S700 Cables

Power Cables

Cable Rating*	Value Line	OD ¹ (mm)	Value Line w/ Brake	OD ¹ (mm)	Flex Line	OD ¹ (m-m)	Flex Line w/ Brake	OD ¹ (mm)
3/6 A	VP-507BEAN-XX	9.4	VP-508CFAN-XX	10.9	CP-507CCAN-XX-X	12.7	CP-507CDAN-XX-X	14.5
12 A	VP-507BEAN-XX	10.3	VP-508CFAN-XX	10.9	CP-507CCAN-XX-X	12.7	CP-507CDAN-XX-X	14.5

Cable Rating*	Value Line	OD ¹ (mm)	Value Line w/ Brake	OD ¹ (mm)	Flex Line	OD ¹ (mm)	Flex Line w/ Brake	OD ¹ (mm)
20 A	VP-508DEAN-XX	11.7	VP-508DFAN-XX	12.9	CP-508DCAN-XX-X	14.5	CP-508DDAN-XX-X	16.6
24A	Not Available	N/A	Not Available	N/A	CP-508EBDN-XX-X	18.3	CP-508EBDN-XX-X	18.3

*Continuous current

¹Outside diameter

Feedback Cables

Feedback Type	Value Line	OD (mm)	Flex Line	OD (mm)
SFD	VF-DA474N-XX	6.7	CF-DA0374N-XX-X	7.5
EnDat 2.1/BiSS	VF-SB4474N-XX	9.7	CF-SB7374N-XX-X	11.2
Resolver	VF-RA2474N-XX	9.7	CF-RA2574N-XX-X	9.5
Incremental/comcoder	Not available	N/A	CF-CB7374N-XX-X	11.2

11.4.1 Order Codes for S700 Motor Power Cables

11.4.1.1 S701-712 Order Codes

With shield clamp for amplifier's end, motor connector size 1 (up to 22A):

Article	Order Code
Motor cable 5m (4x1)	DE-107473
Motor cable 10m (4x1)	DE-107474
Motor cable 15m (4x1)	DE-107475
Motor cable 20m (4x1)	DE-107476
Motor cable 25m (4x1)	DE-107477
Motor cable 5m (4x1+(2x0.75))	DE-107479
Motor cable 10m (4x1+(2x0.75))	DE-107480
Motor cable 15m (4x1+(2x0.75))	DE-107481
Motor cable 20m (4x1+(2x0.75))	DE-107482
Motor cable 25m (4x1+(2x0.75))	DE-107483

With shield plate at amplifier's end, motor connector size 1 (up to 22A):

Article	Order Code
Motor cable 5m (4x1.5)	DE-200456
Motor cable 10m (4x1.5)	DE-200457
Motor cable 15m (4x1.5)	DE-200458
Motor cable 20m (4x1.5)	DE-200459
Motor cable 25m (4x1.5)	DE-200460
Motor cable 5m (4x1.5+(2x0.75))	DE-200462
Motor cable 10m (4x1.5+(2x0.75))	DE-200463
Motor cable 15m (4x1.5+(2x0.75))	DE-200464
Motor cable 20m (4x1.5+(2x0.75))	DE-200465
Motor cable 25m (4x1.5+(2x0.75))	DE-200466
Motor cable 5m (4x2.5)	DE-200468

Article	Order Code
Motor cable 10m (4x2.5)	DE-200469
Motor cable 15m (4x2.5)	DE-200470
Motor cable 20m (4x2.5)	DE-200471
Motor cable 25m (4x2.5)	DE-200472
Motor cable 5m (4x2.5+(2x1))	DE-200474
Motor cable 10m (4x2.5+(2x1))	DE-200475
Motor cable 15m (4x2.5+(2x1))	DE-200476
Motor cable 20m (4x2.5+(2x1))	DE-200477
Motor cable 25m (4x2.5+(2x1))	DE-200478
Motor cable 5m (4x4)	DE-200618
Motor cable 10m (4x4)	DE-200619
Motor cable 15m (4x4)	DE-200620
Motor cable 20m (4x4)	DE-200621
Motor cable 25m (4x4)	DE-200622
Motor cable 5m (4x4+(2x1))	DE-200623
Motor cable 5m (4x4+(2x1))	DE-200624
Motor cable 5m (4x4+(2x1))	DE-200625
Motor cable 5m (4x4+(2x1))	DE-200626
Motor cable 5m (4x4+(2x1))	DE-200627

11.4.1.2 S724 Order Codes

With shield plate at amplifier's end, motor connector size 1.5

Article	Order Code
Motor cable 5m (4x6)	DE-201579
Motor cable 10m (4x6)	DE-201580
Motor cable 15m (4x6)	DE-201581
Motor cable 20m (4x6)	DE-201582
Motor cable 25m (4x6)	DE-201583
Motor cable 5m (4x6+(2x1))	DE-201584
Motor cable 10m (4x6+(2x1))	DE-201585
Motor cable 15m (4x6+(2x1))	DE-201586
Motor cable 20m (4x6+(2x1))	DE-201587
Motor cable 25m (4x6+(2x1))	DE-201588

11.4.1.3 S748 Order Codes

With shield plate at amplifier's end, motor connector size 1.5

Article	Order Code
Motor cable 5m (4x10)	DE-201589
Motor cable 10m (4x10)	DE-201590
Motor cable 15m (4x10)	DE-201591
Motor cable 20m (4x10)	DE-201592
Motor cable 25m (4x10)	DE-201593
Motor cable 5m (4x10+(2x1))	DE-201594
Motor cable 10m (4x10+(2x1))	DE-201595

Article	Order Code
Motor cable 15m (4x10+(2x1))	DE-201596
Motor cable 20m (4x10+(2x1))	DE-201597
Motor cable 25m (4x10+(2x1))	DE-201598

11.4.2 Preparing Motor Cables (Motor End)

11.4.2.1 Motor Series AKM2...8, 6SMx7, DBL2...6, DBK

Please note that different conductor cross-sections are required for different motors, and that for motors with a holding brake the brake signals are also attached through this connector.

Connections: The view is as seen from the contact side of the connector:

Standard (size 1), wire max 4mm ²				
	Pin	Signal	Pin	Signal
	1	U2	A	+ Br
	4	V2	B	- Br
	3	W2	C	n.c.
	⏏ (2)	PE	D	n.c.

Option H (size 1.5), wire max. 10mm ²				
	Pin	Signal	Pin	Signal
	U	U2	+	+ Br
	V	V2	-	- Br
	W	W2	1	n.c.
	⏏	PE	2	n.c.

11.4.3 Preparing Cables for Drive (S701 to S724)

The motor is connected to the S701...724 by a Power Combicon connector (see p.71). You can obtain the connector kit from us (connector, housing, shield plate, rubber bushes, installation material) with the order-code DE-200453. Please take note that the connector can accept a maximum conductor cross-section of 6mm².

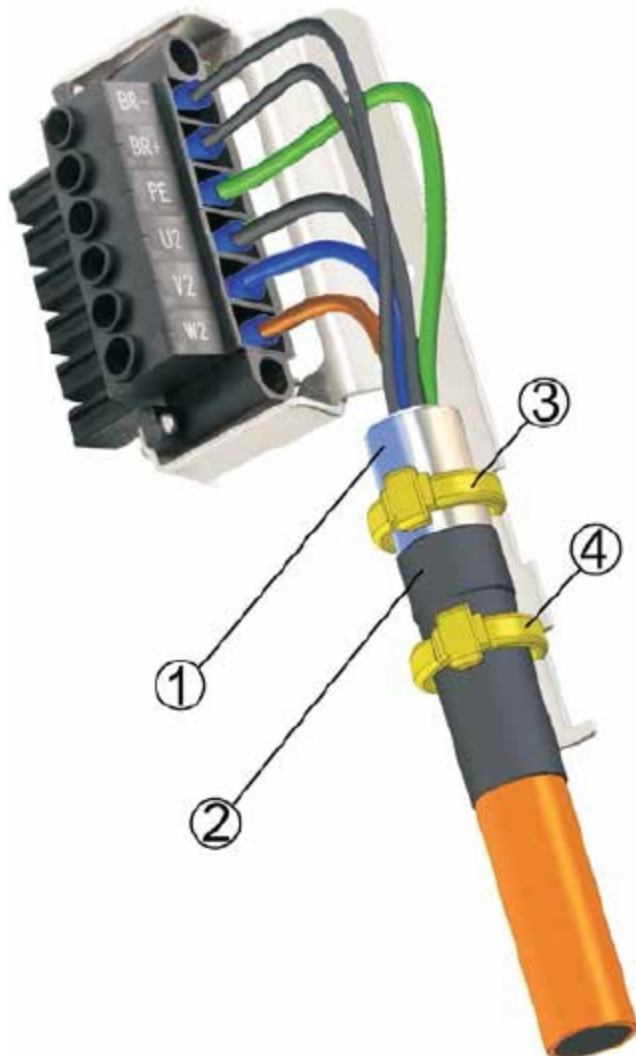

Strip the external cable sheath to a length of approx. 120 mm, **taking care not to damage the braided shield**. Push the braided shield (1) back over the cable and secure with a rubber sleeve (2) or shrink sleeve.

Shorten all the wires apart from the protective earth (PE) wire (green/yellow) by about 20 mm so that the PE wire is now the longest wire. Strip all wires and fit wire end ferrules.

Secure the braided shield of the cable to the shroud with a cable tie or a hose clamp (3) and use a second tie (4) to fasten the cable over the rubber sleeve.

Wire the connector as shown in the connection diagram. Plug in the connector to the socket on the front of the S701...724.

Screw the connector in place. This ensures that there is conductive contact over a large surface area between the braided shield and the front panel.

11.5 CANopen Bus Cable Specifications

All cables supplied with AKD and S700 drives are RoHS compliant.

11.5.1 CANopen Cable P-AKD-CAN-RJ-z-zz

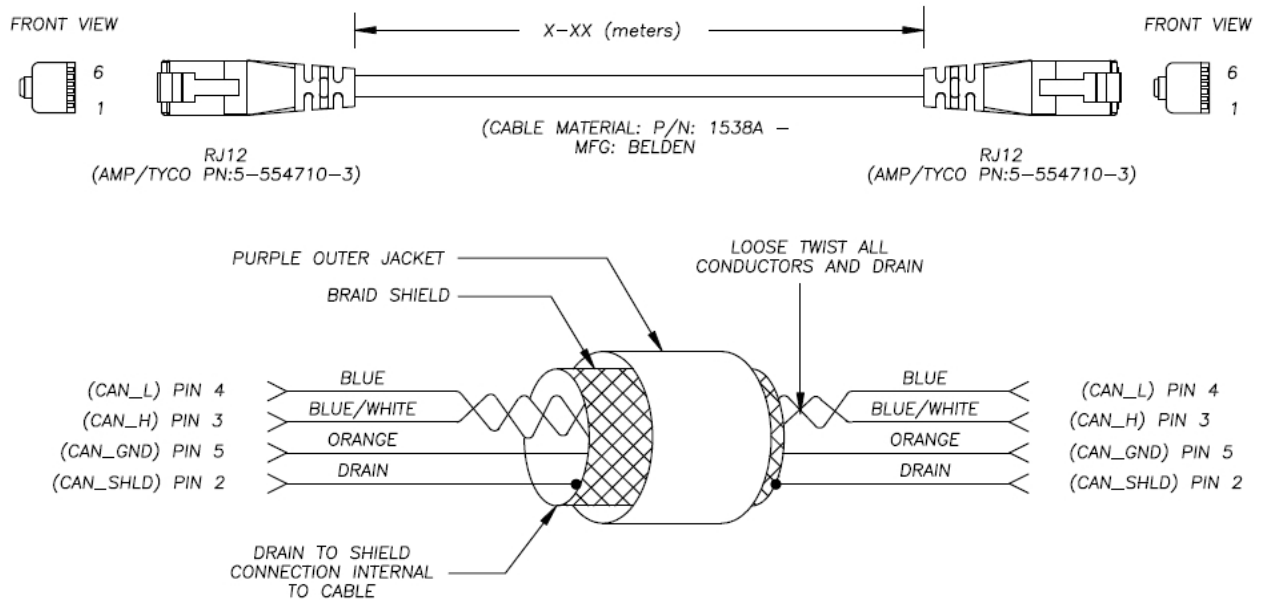

Cable Specifications	
Outside diameter	6.7 mm ± 0.2 mm
RoHS Compliant	Yes
Length:	
PAKD-CANRJ-0-15	0.15 m
PAKD-CANRJ-0-30	0.3 m
PAKD-CANRJ-1-00	1 m
PAKD-CANRJ-3-00	3 m

11.5.2 CANopen Cable P-AKD-CAN-TERM

FRONT VIEW

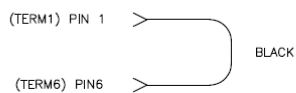
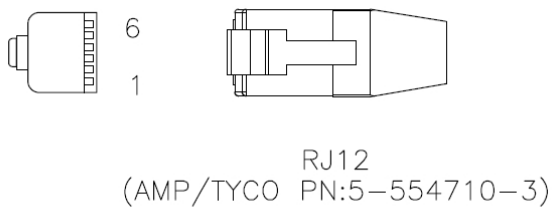

11.5.3 CANopen Cable PAKD-CAN-9D-0-15

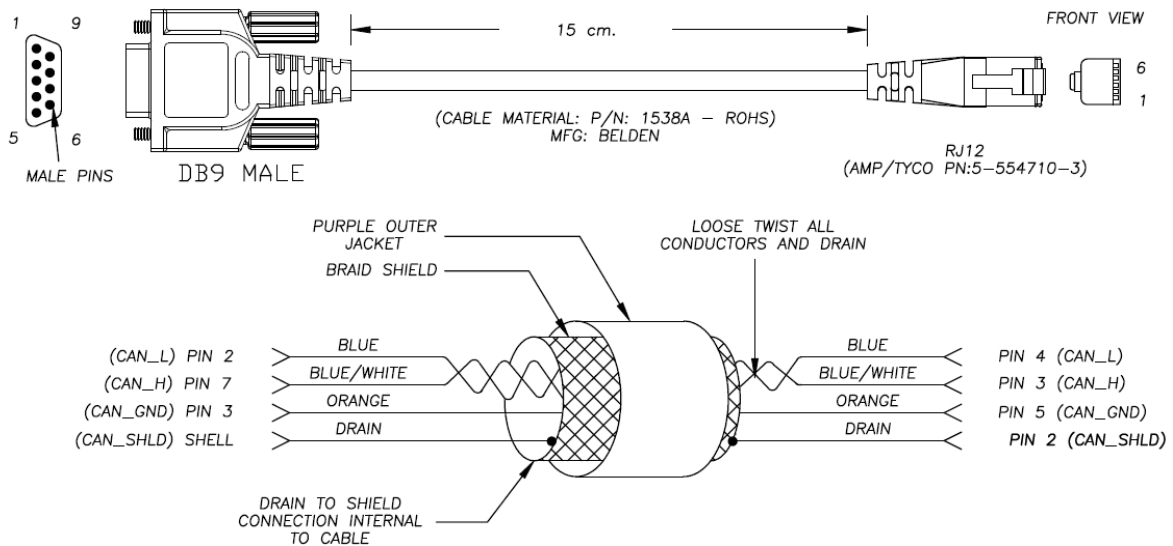

11.5.4 CANopen Cable PAKD-CAN-FL-3-00

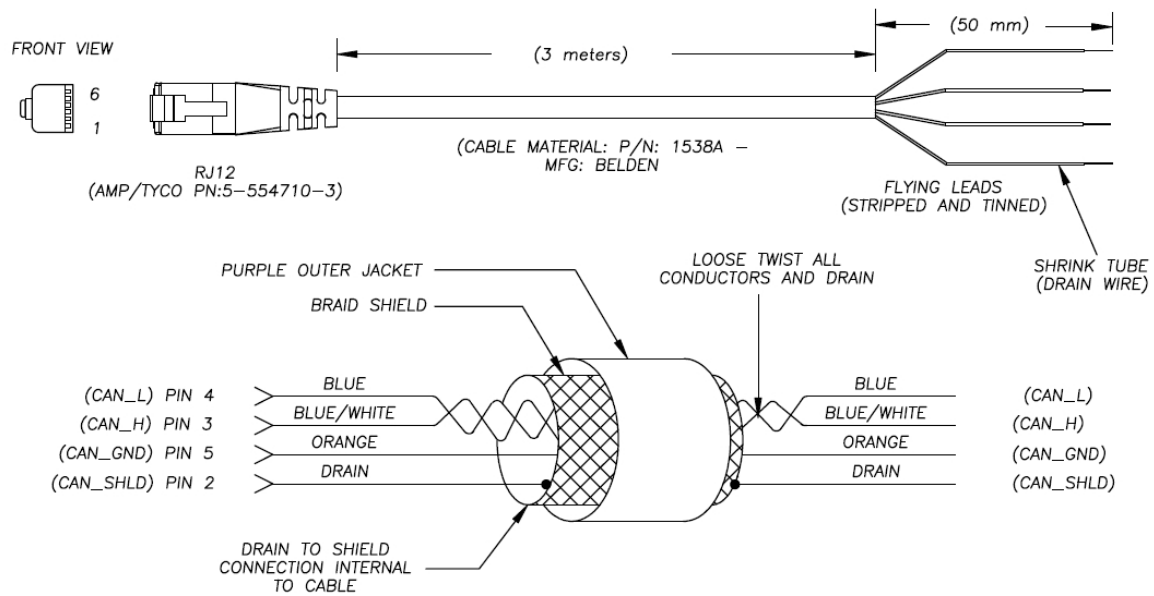

11.6 Motor Power Cable Specifications

All cables supplied with AKD and S700 drives are RoHS compliant.

11.6.1 Cable Routing Standards

UL 508C and UL 508A indicate that wires, when routed together, shall be rated for the highest voltage involved in all of the circuits. This means that value line feedback cables which are 300V rated are not appropriate when routed directly next to motor power cables that carry more voltage than 300V. They should be physically separated. Performance line cables are recommended when this is a concern.

The NFPA 70 (NEC) article 300.3(C)(1) says that for circuits that are 600V or less, conductors of ac and dc circuits shall be permitted to occupy the same equipment wiring enclosure, cable, or raceway. All conductors shall have an insulation rating equal to at least the maximum circuit voltage applied to any conductor within the enclosure, cable, or raceway.

11.6.2 AKD 1.5 – 6 A Power Cable, VP-507BEAN-xx

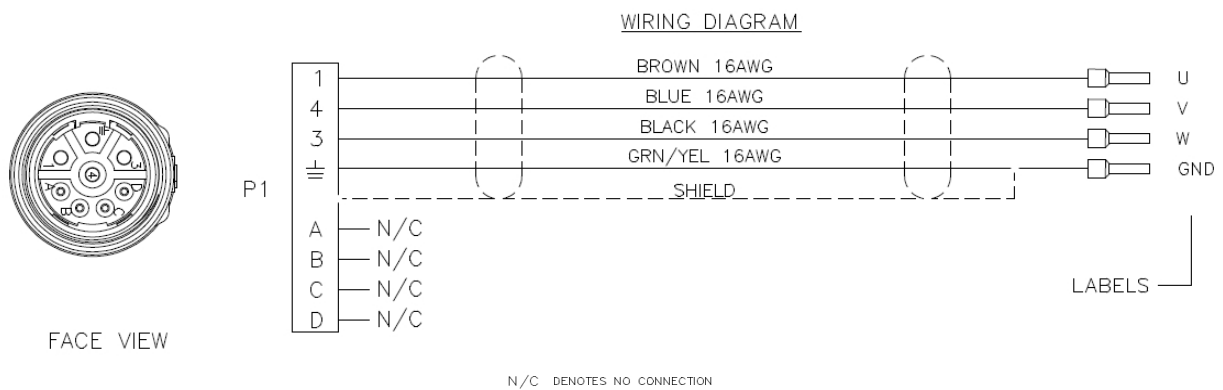

Cable Specifications	
Cable jacket material	TPE
Outside diameter	9.4 mm ± 0.25 mm
Bend radius	94 mm
Static flex rating	Not rated
Dynamic flex rating	Not rated
Temperature rating	105 C
Voltage rating	600 V (see Cable Routing Standards)
RoHS Compliant	Yes
Assembly Weight:	
VP-507BEAN-01	0.258 kg
VP-507BEAN-03	0.536 kg
VP-507BEAN-06	0.955 kg
VP-507BEAN-09	1.372 kg
VP-507BEAN-12	1.789 kg

11.6.3 AKD 12 A Power Cable, VP-508CEAN-zz

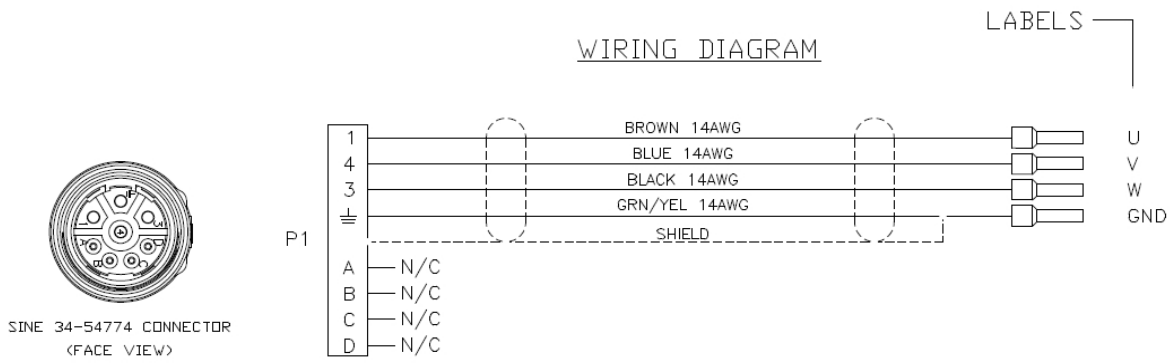

N/C DENOTES NO CONNECTION

Cable Specifications	
Cable jacket material	TPE
Outside diameter	10.25 mm ± 0.30 mm
Bend radius	102.5 mm
Static flex rating	Not rated
Dynamic flex rating	Not rated
Temperature rating	105 C
Voltage rating	600 V (see Cable Routing Standards)
RoHS Compliant	Yes
Assembly Weight:	
VP-508CEAN-01	0.247 kg
VP-508CEAN-03	0.521 kg
VP-508CEAN-06	0.942 kg
VP-508CEAN-09	1.363 kg
VP-508CEAN-12	1.784 kg

11.6.4 AKD 12 A Power Cable with Brake, VP-508CFAN-zz

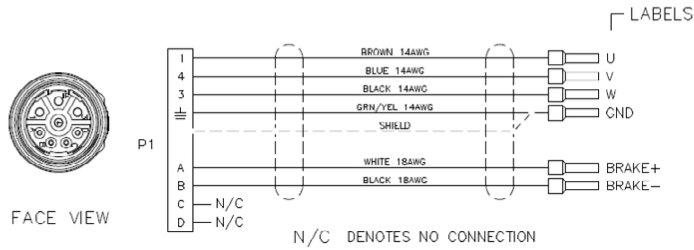
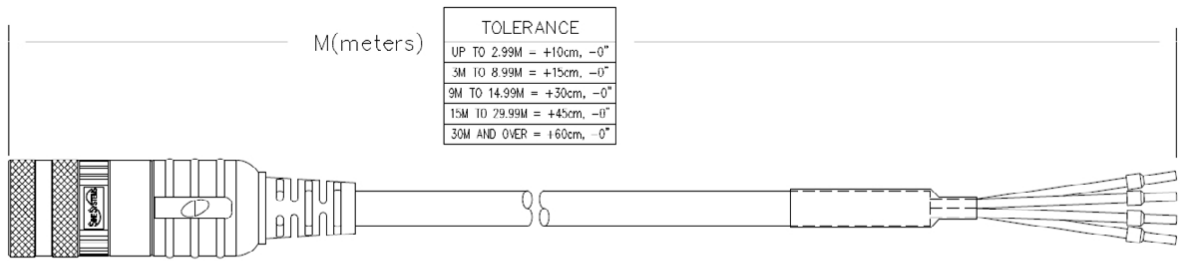

Cable Specifications	
Cable jacket material	TPE
Outside diameter	10.90 mm ± 0.30 mm
Bend radius	109 mm
Static flex rating	Not rated
Dynamic flex rating	Not rated
Temperature rating	105 C
Voltage rating	600 V (see Cable Routing Standards)
RoHS Compliant	Yes
AWM Style	UL20328
Assembly Weight:	
VP-508CFAN-01-0	0.256 kg
VP-508CFAN-03-0	0.767 kg
VP-508CFAN-06-0	1.534 kg
VP-508CFAN-09-0	2.301 kg
VP-508CFAN-12-0	3.068 kg

11.6.5 AKD 24 A Power Cable with Brake, VP-508DEAN-zz

WIRING DIAGRAM

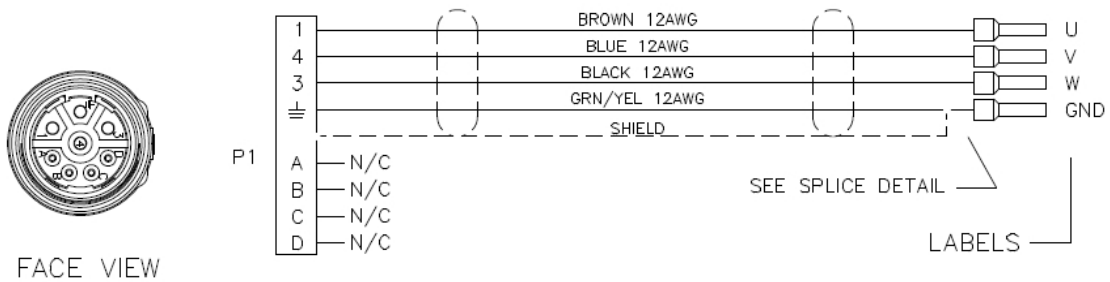

N/C DENOTES NO CONNECTION

Cable Specifications	
Cable jacket material	TPE
Outside diameter	11.70 mm ± 0.30 mm
Bend radius	117 mm
Static flex rating	Not rated
Dynamic flex rating	Not rated
Temperature rating	105 C
Voltage rating	600 V (see Cable Routing Standards)
RoHS Compliant	Yes
Assembly Weight:	
VP-508DEAN-01-0	0.292 kg
VP-508DEAN-03-0	0.874 kg
VP-508DEAN-06-0	1.750 kg
VP-508DEAN-09-0	2.622 kg
VP-508DEAN-12-0	3.496 kg

11.6.6 AKD 24 A Power Cable with Brake, VP-508DFAN-zz

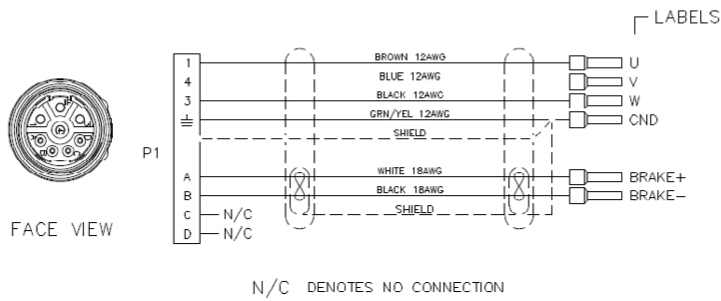
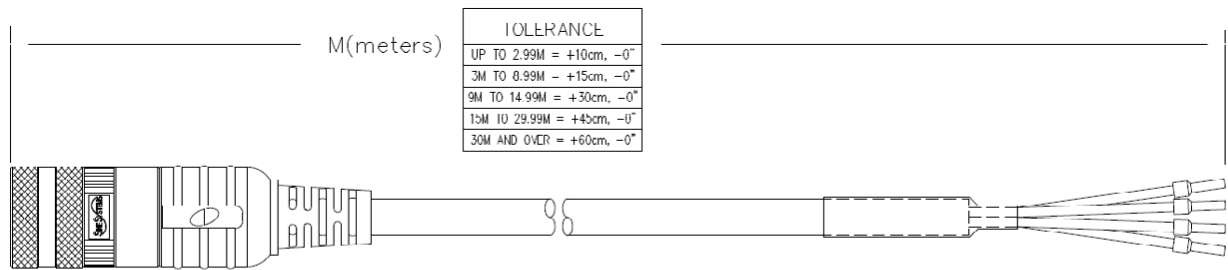

Cable Specifications	
Cable jacket material	TPE
Outside diameter	12.90 mm ± 0.20 mm
Bend radius	129 mm
Static flex rating	Not rated
Dynamic flex rating	Not rated
Temperature rating	105 C
Voltage rating	600 V (see Cable Routing Standards)
RoHS Compliant	Yes
AWM Style	UL20328
Assembly Weight:	
VP-508DFAN-01-0	0.328 kg
VP-508DFAN-03-0	0.983 kg
VP-508DFAN-06-0	1.966 kg
VP-508DFAN-09-0	2.949 kg
VP-508DFAN-12-0	3.932 kg

This page intentionally left blank.

11.7 Motor Feedback Cable Specifications

All cables supplied with AKD and S700 drives are RoHS compliant.

11.7.1 Cable Routing Standards

UL 508C and UL 508A indicate that wires, when routed together, shall be rated for the highest voltage involved in all of the circuits. This means that value line feedback cables which are 300V rated are not appropriate when routed directly next to motor power cables that carry more voltage than 300V. They should be physically seperated. Performance line cables are recommended when this is a concern.

The NFPA 70 (NEC) article 300.3(C)(1) says that for circuits that are 600V or less, conductors of ac and dc circuits shall be permitted to occupy the same equipment wiring enclosure, cable, or raceway. All conductors shall have an insulation rating equal to at least the maximum circuit voltage applied to any conductor within the enclosure, cable, or raceway.

11.7.2 Motor Feedback Cable, VF-DA0-474N-zz

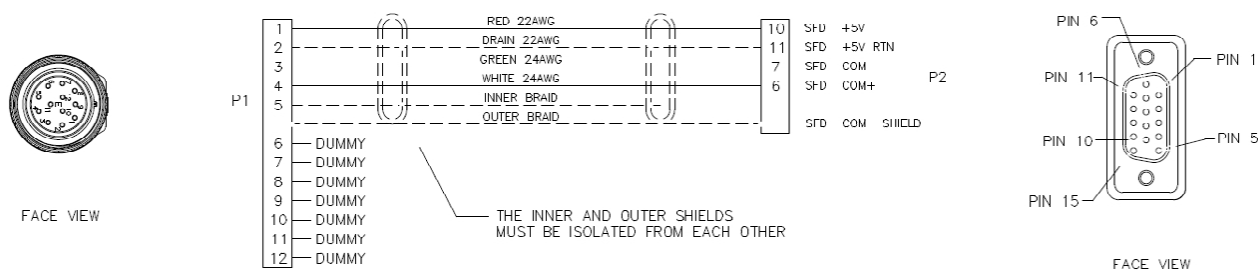

N/C DENOTES NO CONNECTION

Cable Specifications	
Cable jacket material	TPE
Outside diameter	6.7 mm ± 0.2 mm
Bend radius	67 mm
Static flex rating	Not rated
Dynamic flex rating	Not rated
Temperature rating	105 C
Voltage rating	300 V (see Cable Routing Standards)
RoHS Compliant	Yes
Assembly Weight:	
VF-DA0-474N-01	0.211 kg
VF-DA0-474N-03	0.357 kg
VF-DA0-474N-06	0.568 kg
VF-DA0-474N-09	0.779 kg
VF-DA0-474N-12	0.99 kg

11.7.3 Feedback Resolver Cable, VF-RA2474N-zz

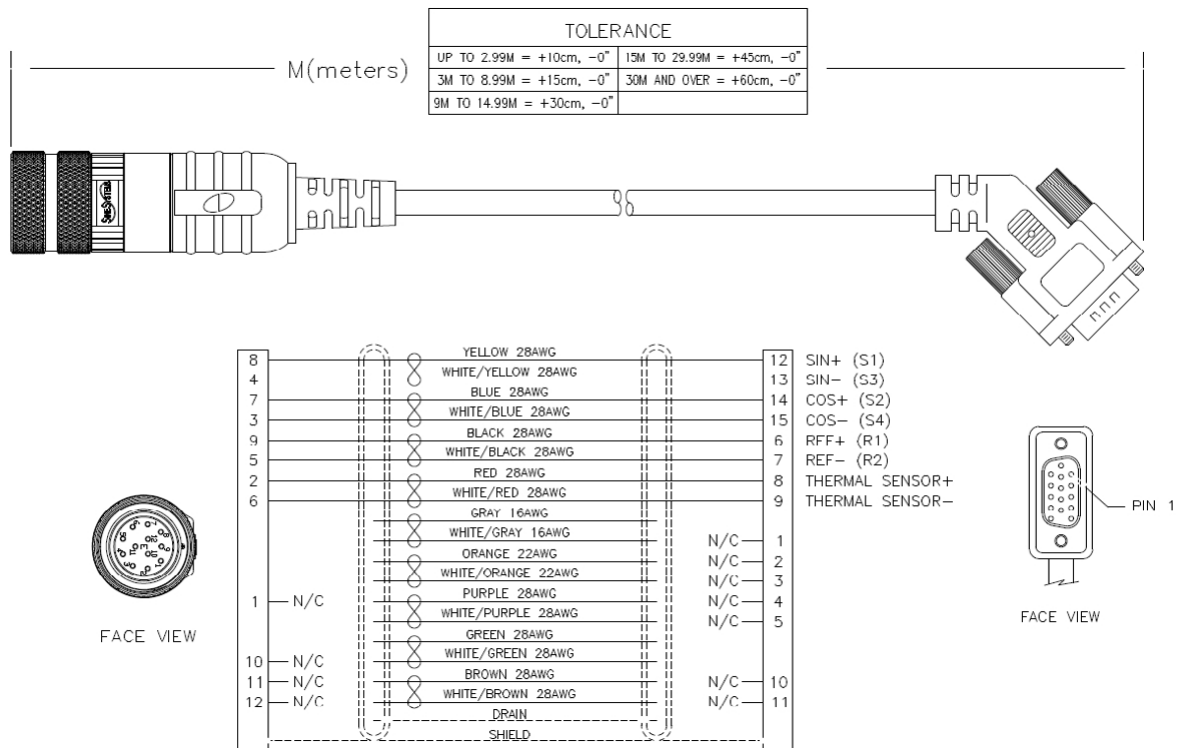

∞ = TWISTED PAIR
 N/C DENOTES NO CONNECTION
 CONNECTOR BACKSHELL SHIELDED 360° (BOTH ENDS)

Cable Specifications	
Cable jacket material	TPE
Outside diameter	9.65 mm ± 0.35 mm
Bend radius	96.5 mm
Static flex rating	Not rated
Dynamic flex rating	Not rated
Temperature rating	105 C
Voltage rating	300 V (see Cable Routing Standards)
AWM Style	UL20327
RoHS Compliant	Yes
Assembly Weight:	
VF-RA2474N-01-0	0.273 kg
VF-RA2474N-03-0	0.551 kg
VF-RA2474N-06-0	0.968 kg
VF-RA2474N-09-0	1.385 kg
VF-RA2474N-12-0	1.793 kg

11.7.4 Sine Encoder Feedback Cable, VF-SB4474N-zz

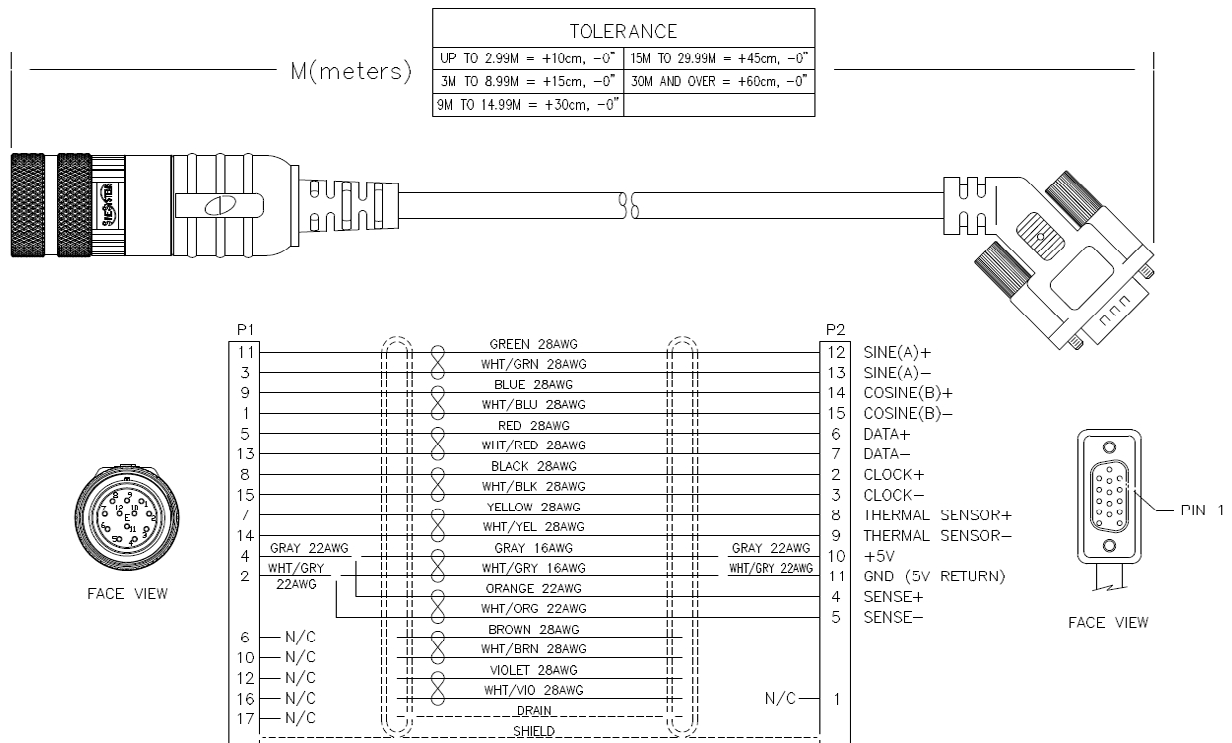

∞ = TWISTED PAIR

N/C DENOTES NO CONNECTION

CONNECTOR BACKSHELL SHIELDED 360° (BOTH ENDS)

Cable Specifications	
Cable jacket material	TPE
Outside diameter	9.65 mm ± 0.35 mm
Bend radius	96.5 mm
Static flex rating	Not rated
Dynamic flex rating	Not rated
Temperature rating	105 C
Voltage rating	300 V (see Cable Routing Standards)
AWM Style	UL20327
RoHS Compliant	Yes
Assembly Weight:	
VF-SB4474N-01-0	0.269 kg
VF-SB4474N-03-0	0.547 kg
VF-SB4474N-06-0	0.974 kg
VF-SB4474N-09-0	1.386 kg
VF-SB4474N-12-0	1.798 kg

11.7.5 Resolver Cables for S700/AKD



All the motors in our range feature the same 12-pin connector for the resolver connection. This connector is also used for the connections from the motor's thermal protection contact to the servo amplifier. The servo amplifiers have a Sub-D female connector for the connection of a resolver and the thermal protection contact. The cable shield is connected to the servo amplifier via the connector housing.

11.7.5.1 Resolver Cable Order Codes

Article	S700		AKD	
	Length	Order Code	Length	Order Code
Resolver Cable (4x(2x0.25))	5m	DE-84972	1m	CFR0A1-002-001-00
Resolver Cable (4x(2x0.25))	10m	DE-84973	3m	CFR0A1-002-003-00
Resolver Cable (4x(2x0.25))	50m	DE-84974	6m	CFR0A1-002-006-00
Resolver Cable (4x(2x0.25))	20m	DE-84975	12m	CFR0A1-002-012-00
Resolver Cable (4x(2x0.25))	30m	DE-87655	24m	CFR0A1-002-024-00

11.7.5.2 Preparing Resolver Cables

For cable lengths up to 100m use a shielded and sheathed cable, with cores as twisted pairs (suggestion acc. to DIN 47100). Please consult our customer support for cables longer than 100m.

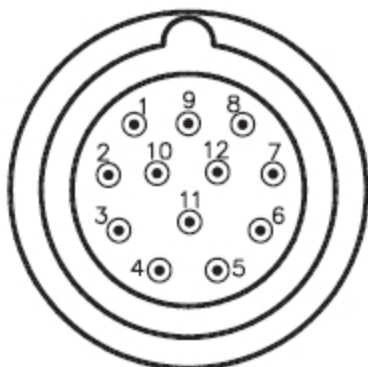

View: solder side of the motor connector.

S700 Pin	AKD X10 High Density Pin	Pair No.	Core Color acc. to IEC 60757	Motor End Pin	Function 6SM, DBL/DBK, AKM
-		-	-	1	n.c.
2	8	4	BU	2	Thermal Protection
3	15	2	YE	3	S4 Cosine+
4	13	3	PK	4	S3 Sine-
5	7	1	BN	5	R2 Reference+
6	9	4	RD	6	Thermal Protection
7	14	2	GN	7	S2 Cosine-
8	12	3	GY	8	S1 Sine+
9	6	1	WH	9	R1 Reference-

11.7.6 Encoder Cables for S700/AKD



All the motors in our range feature the same 17-pin connector for the encoder connection (EnDat, HIPERFACE, BiSS etc.). This connector is also used for the connections from the motor's thermal protection contact to the servo amplifier. The servo amplifiers have a Sub-D female connector for the connection of the encoder and the thermal protection contact. The cable shield is connected to the servo amplifier via the connector housing.

11.7.6.1 Encoder Cable Order Codes

Article	S700		AKD	
	Length	Order Code	Length	Order Code
Encoder Cable (7x(2x0.25))	5m	DE-90287	1m	CFE0A1-002-001-00
Encoder Cable (7x(2x0.25))	10m	DE-91019	3m	CFE0A1-002-003-00
Encoder Cable (7x(2x0.25))	15m	DE-91811	6m	CFE0A1-002-006-00
Encoder Cable (7x(2x0.25))	20m	DE-91807	12m	CFE0A1-002-012-00
Encoder Cable (7x(2x0.25))	30m	DE-92205	24m	CFE0A1-002-024-00

11.7.6.2 Preparing Encoder Cables

Up to a cable length of 50m, use a shielded and sheathed cable with cores in twisted pairs (suggestion acc. to DIN 47100). Please consult our customer support for cables longer than 50m.

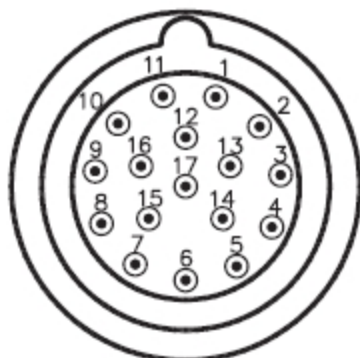

View: solder side of the motor connector.

S700	Pin: Amplifier End		Pair	Core Color acc. to IEC 60757	Pin: Motor End
	AKD	AKD			
	EnDat	BiSS	Hiperface		ECN/EQN/SRS/SRM
1	15	12	1	WH	1
2	11	11	6	RD/BU	2
3	13	14	2	GN	3
4	10	10	6	GY/PK	4
5	6	6	3	GY	5
6	-	-	-	-	-
7	9	9	7	BN/GN	7
8	2	-	4	BU	8
9	14	13	1	BN	9
10	5	5-4	5	VT	10

S700	Pin: Amplifier End AKD		Pair	Core Color acc. to IEC 60757	Pin: Motor End Encoder ECN/EQN/SRS/SRM
	EnDat BiSS	Hiperface			
11	12	15	2	YE	11
12	4	4-5	5	BK	12
13	7	7	3	PK	13
14	8	8	7	WH/GN	14
15	3	-	4	RD	15

11.7.7 ComCoder Cables for S700/AKD



All the motors in our range feature the same 17-pin connector for the ComCoder connection. This connector is also used for the connections from the motor's thermal protection contact to the servo amplifier. The servo amplifiers have a Sub-D female connector for the connection of the ComCoder and the thermal protection contact. The cable shield is connected to the servo amplifier via the connector housing.

11.7.7.1 ComCoder Cable Order Codes

Article	S700		AKD	
	Length	Order Code	Length	Order Code
ComCoder Cable (8x(2x0.25))	5m	DE-107915	1m	CFC0A1-002-001-00
ComCoder Cable (8x(2x0.25))	10m	DE-107916	3m	CFC0A1-002-003-00
ComCoder Cable (8x(2x0.25))	15m	DE-107917	6m	CFC0A1-002-006-00
ComCoder Cable (8x(2x0.25))	20m	DE-107918	12m	CFC0A1-002-012-00
ComCoder Cable (8x(2x0.25))	30m	DE-107919	24m	CFC0A1-002-024-00

11.7.7.2 Preparing Comcoder Cable

Up to a cable length of 25m, use a shielded and sheathed cable with cores in twisted pairs (suggestion acc. to DIN 47100). Please consult our customer support for cables longer than 25m.

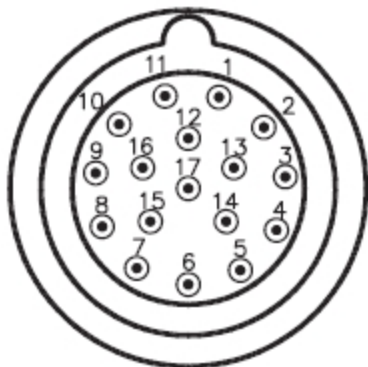

View: Solder side of the motor connector.

Pin Amplifier End S700	Pin AKD X10 High Density	Pair	Core color to IEC 60757	Pin: Motor End
1	14	1	WH	1
2	11	6	RD/BU	7
3	12	2	GN	3
4	10	6	GY/PK	10
5	6	3	GY	5
6	1	4	RD	15
7	9	7	BN/GN	8
8	2	4	BU	16
9	15	1	BN	2
10	5	5	VT	7
11	13	2	YE	4
12	4	5	BK	10

Pin Amplifier End S700	Pin AKD X10 High Density	Pair	Core color to IEC 60757	Pin: Motor End
13	7	3	PK	6
14	8	7	WH/GN	9
15	3	8	WH/YE	17

About Kollmorgen

Kollmorgen is a leading provider of motion systems and components for machine builders. Through world-class knowledge in motion, industry-leading quality and deep expertise in linking and integrating standard and custom products, Kollmorgen delivers breakthrough solutions that are unmatched in performance, reliability and ease-of-use, giving machine builders an irrefutable marketplace advantage.

For assistance with your application needs, visit www.kollmorgen.com or contact us at:

North America

KOLLMORGEN

203A West Rock Road
Radford, VA 24141 USA

Internet www.kollmorgen.com

E-Mail support@kollmorgen.com

Tel.: +1 - 540 - 633 - 3545

Fax: +1 - 540 - 639 - 4162

Europe

KOLLMORGEN Europe GmbH

Pempelfurtstraße 1
40880 Ratingen, Germany

Internet www.kollmorgen.com

E-Mail technik@kollmorgen.com

Tel.: +49 - 2102 - 9394 - 0

Fax: +49 - 2102 - 9394 - 3155

Asia

KOLLMORGEN

Rm 2205, Scitech Tower, China
22 Jianguomen Wai Street

Internet www.kollmorgen.com

E-Mail sales.asia@kollmorgen.com

Tel.: +86 - 400 666 1802

Fax: +86 - 10 6515 0263

KOLLMORGEN®

Because Motion Matters™