

High Performance Microstep Systems

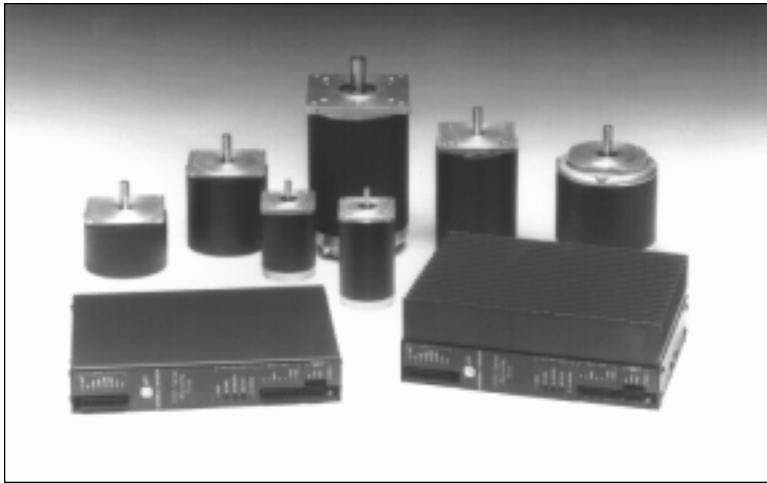

Common Features

- Torques from 65 to 3,000 oz-in. with speeds to 3,000 RPM continuous.
- Dip switch selectable resolutions up to 50,800 steps per revolution.
- Mid range stabilization prevents loss of motor synchronization.
- Dip switch selectable automatic low power feature.
- Optical isolation of all inputs and output provides high noise immunity.
- Full short circuit protection.
- DIP switch selectable current settings from 0.2-8.2 Amps.
- Accepts 95-135 VAC 50/60 Hz input.
- Status/Fault LED indicators.
- Optional maximum power P315-P with fan kit.

Description

The P315 Series of Drives and the P315X Series of Drive/Indexer Systems provide high torque, high speed and high resolution to help you solve your most demanding motion control applications.

The P315 packaged drive section is a state-of-the-art microstep drive with the translating and power stages needed to control virtually any hybrid step motor. By combining the ultra efficient MOSFET amplifiers, versatile H-bridge technology, and microprocessor controlled logic, the P315 provides outstanding speed/torque performance.

The P315X Indexer section automatically generates precise ramping routines; interfaces to your environment through the use of RS-232 communications, limit inputs, and programmable I/O; and for applications utilizing encoder capabilities, position maintenance and stall detection are available. Best of all, API's Intelli-Command Language (ICL) indexer software was designed for use by individuals without computer programming experience. Through the use of plain English type commands, your motion application will be up and running quickly, providing you with dividends long before other motion control systems.

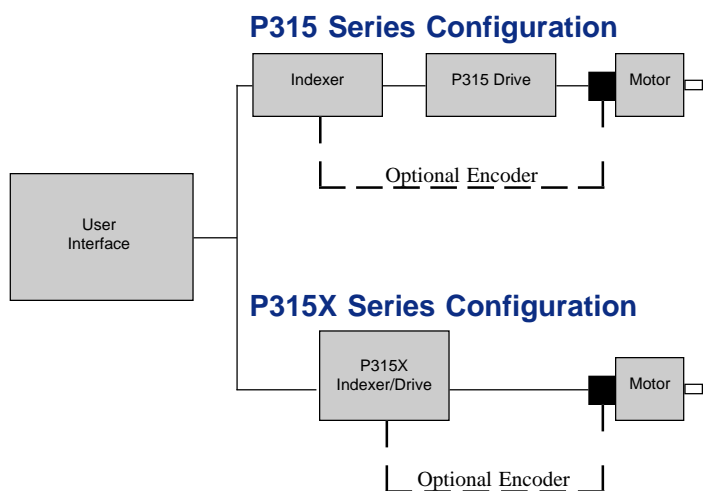

P315X Additional Features:

- Includes a powerful built-in indexer.
- Easy to learn "Plain English" instructions.
- RS-232 communications to 19,200 Baud allows daisy chaining of multiple devices.
- Home, End-of-Travel plus 13 programmable inputs and 8 programmable outputs.
- Encoder capabilities include position maintenance and stall detection for closed loop positioning.
- Built-in editor allows creation of up to 88 different motion programs.

COMMON SPECIFICATIONS FOR P315 AND P315X:

DRIVE TYPE	2 phase, bipolar, constant current, MOSFET chopper, 20 KHz fixed.
RESOLUTIONS	200, 400, 1000, 2000, 5000, 10000, 18000, 20000, 21600, 25000, 25400, 25600, 36000, 50000, 50800.
WAVEFORMS	Switch selectable microstep shaping. Pure Sine; $\pm 2\%$, $\pm 5\%$, or -8% 3rd harmonic included. Mid-Range stabilization prevents loss of motor synchronization.
POWER	
Inputs	90-135 VAC 50/60 Hz, +5VDC for Logic 100mA min.
Output	P315-L 0.2-6.2 amps/phase. P315-H and P315-P 2.0-8.2 amps/phase. Dip switch selectable.
PROTECTION	
Short Circuit	Phase to phase, phase to ground.
Over Temperature	Internal air temp exceeds 140° F (60° C).
Fan Kit	Optional fan kit available (FK-P315).
FAULT OUTPUT	Sinking output to OUTCOM, 5-24 VDC, 60mA max. Disable LED on.
LOW POWER MODE	
Auto Reduce	DIP switch enabled. Current drops to 50% of selected value if no step pulses are received in one second.
ENVIRONMENTAL	
Temperature	Drive heatsink max. 140° F (60° C); Motor case max. 212° F (100° C); Storage -40° to 185° F (-40° to 85° C)
Humidity	0-95%, non-condensing.

P315 ADDITIONAL SPECIFICATIONS:**INPUTS**

TYPE	Optically isolated. TTL compatible.
OPTO IN	Optical isolation power. User supplies +5VDC at 100 milliamps min.
STEP	Requires 0.5 microsecond minimum width, 1 MHz max. pulse rate, steps on trailing edge.
DIRECTION	CW/CCW.
LOW POWER	HI/LOPWR. Reduces motor current to 50% of selected value.
NO POWER	ENA/NOPWR. Turns off motor current.
RESET	RUN/RESET. Resets logic and establishes zero phase condition.

P315X ADDITIONAL SPECIFICATIONS:**OPERATIONAL**

Acceleration	Optimal non-linear mathematical function.
Step Accuracy	± 0 steps.
Position Range	± 2.1 billion steps.
Speed Range	0 to 750,000 pulses/second. $\pm 1\%$ maximum speed.

COMMUNICATIONS

Type	RS-232C serial, 3 wire implementation (Tx, Rx, Gnd).
Baud Rates	1200, 2400, 4800, 9600 and 19200.
Mode	Full Duplex.
Format	8 data bits; 1 stop bit, no parity; ASCII Characters.
Multi-Axis	Daisy chain up to 36 indexers from a single host RS-232C port.

INPUTS

Type	Optically isolated, 5-24VDC, (P315X-L: 5-15VDC).
Limits	CW, CCW, HOME.
Programmable	Thirteen.
Jog, Hold, Stop	Software assignable to programmable inputs.
Active State	High or low. Software selectable.

OUTPUTS

Type	Optically isolated. Open collector 5-24VDC, (P315X-L: 5-15VDC), 25 milliamp max.
Fault	Overtemp, Undervoltage or Overcurrent.
Programmable	Eight. Active high or low. Software selectable.

ENCODER

Channels	Complementary A & B Channel in quadrature with Z (index) channel. Maximum input frequency rate of 256 kHz on A & B Channel (pre-quadrature).
----------------	---

DIMENSIONS: P315 SERIES [-] denotes millimeters

Unit should be mounted vertically with a 3" horizontal and 2" vertical clearance.

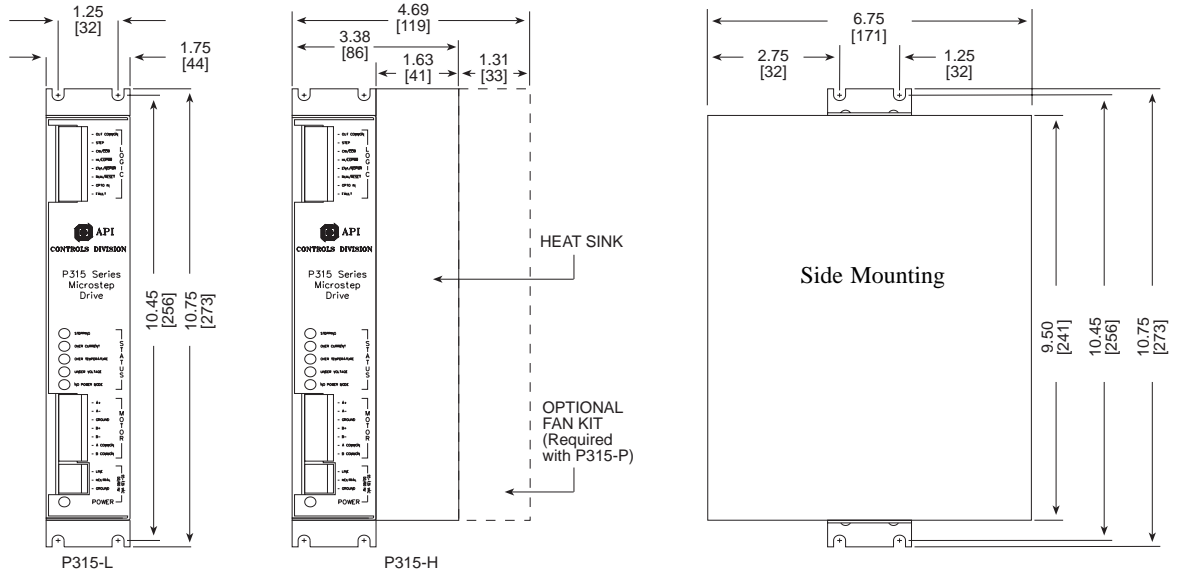

Subject to change without notice.

P315 DRIVE CONNECTIONS/LED'S

STATUS LED'S

STEP	1	Motor Stepping
CURRENT	2	Drive Over Current
TEMP	3	Drive Over Temperature
VOLTAGE	4	Drive Under Voltage
NO PWR	5	Drive in No Power Mode
POWER	6	LED indicating power on

MOTOR

A+	1	Motor Phase A+
A-	2	Motor Phase A-
GND	3	Motor Phase Ground
B+	4	Motor Phase B+
B-	5	Motor Phase B-
A COM	6	Motor Phase A Common
B COM	7	Motor Phase B Common

DRIVE/LOGIC

OUT COM	1	Output Common
STEP	2	Step Signal
CW/CCW	3	Direction Signal
HI/LOPWR	4	High/Low Power Signal
ENA/NOPWR	5	Enable/No Power Signal
RUN/RESET	6	Run/Reset
OPTO IN	7	Opto Input (5VDC)
FAULT	8	Fault Output (5-24 VDC)

AC POWER

LINE	1	AC Input Black Wire (Line)
NEUT	2	AC Input White Wire (Neutral)
GND	3	AC Input Green Wire (Ground)

OPTIONAL DB-25 CONNECTOR

- 1. (+) STEP
- 2. (+) DIRECTION
- 9. FAULT COLL.
- 11. (+) RESET
- 14. (-) STEP
- 15. (-) DIRECTION
- 16. (+) SHUTDOWN
- 17. (-) SHUTDOWN
- 18. (-) LOW PWR
- 19. (+) LOW PWR
- 21. FAULT EMIT.
- 23. (-) RESET

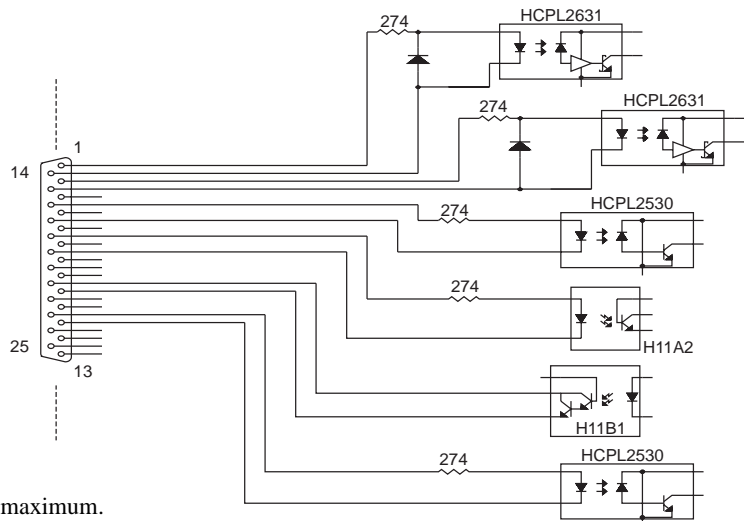

Note: DB25 Input is 15mA maximum.

DIMENSIONS: P315X SERIES

[-] denotes millimeters

Unit should be mounted vertically with a 3" horizontal and 2" vertical clearance.

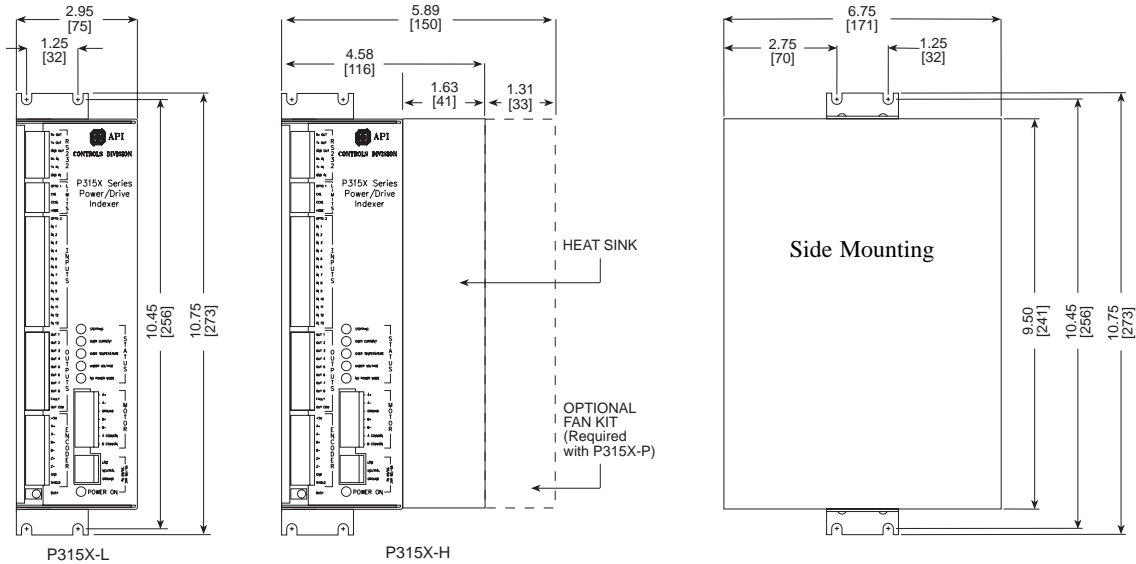

Subject to change without notice.

P315X DRIVE CONNECTIONS/LED'S

STATUS LED'S

STEP	1	Motor Stepping
CURRENT	2	Drive Over Current
TEMP	3	Drive Over Temperature
VOLTAGE	4	Drive Under Voltage
NO PWR	5	Drive in No Power Mode
POWER	6	LED indicating power on

RS-232

Rx OUT	1	Receive Out
Tx OUT	2	Transmit Out
GND OUT	3	Ground Out
Rx IN	4	Receive In
Tx IN	5	Transmit In
GND IN	6	Ground In

LIMITS

OPTO 1	1	Optical Isolation Input (5-24VDC)
CWL	2	Clockwise Travel Limit
CCWL	3	Counter Clockwise Travel Limit
HOME	4	Home Position Reference Input

INPUTS

OPTO 2	1	Optical Isolation Input (5-24VDC)
IN 1	2	Programmable Input #1
IN 2	3	Programmable Input #2
IN 3	4	Programmable Input #3
IN 4	5	Programmable Input #4
IN 5	6	Programmable Input #5
IN 6	7	Programmable Input #6
IN 7	8	Programmable Input #7
IN 8	9	Programmable Input #8
IN 9	10	Programmable Input #9
IN 10	11	Programmable Input #10
IN 11	12	Programmable Input #11
IN 12	13	Programmable Input #12
IN 13	14	Programmable Input #13

OUTPUTS

OUT 1	1	Programmable Output #1
OUT 2	2	Programmable Output #2
OUT 3	3	Programmable Output #3
OUT 4	4	Programmable Output #4
OUT 5	5	Programmable Output #5
OUT 6	6	Programmable Output #6
OUT 7	7	Programmable Output #7
OUT 8	8	Programmable Output #8
FAULT	9	Fault Output
OUT COM	10	Reference Ground For Outputs

ENCODER

+5V	1	5VDC Supply to Encoder
A+	2	TTL Diff. Signal From Ch. A+
A-	3	TTL Diff. Signal From Ch. A-
B+	4	TTL Diff. Signal From Ch. B+
B-	5	TTL Diff. Signal From Ch. B-
Z+	6	TTL Diff. Signal From Ch. Z+
Z-	7	TTL Diff. Signal From Ch. Z-
GND	8	Encoder Ground
SHIELD	9	Shield Connection to Encoder

MOTOR

A+	1	Motor Phase A+
A-	2	Motor Phase A-
GND	3	Motor Phase Ground
B+	4	Motor Phase B+
B-	5	Motor Phase B-
A COM	6	Motor Phase A Common
B COM	7	Motor Phase B Common

AC POWER

LINE	1	AC Input Black Wire (Line)
NEUT	2	AC Input White Wire (Neutral)
GND	3	AC Input Green Wire (Ground)

SYSTEM SELECTIONS / MOTOR DIMENSIONS

Each system includes a Power Supply, Drive, and Motor.

Base System	With Indexer	With Indexer/Encoder	Static Torque Oz-in (N-m)	Motor Width in. (mm)	Motor Length in. (mm)	Drive Version	Motor Model
P315-A231*	P315X-A231*	----	N/A	2.23 (57)	2.00 (51)	P315-L	A231-02*
P315-M231	P315X-M231	P315X-M231E	60 (0.42)	2.23 (57)	2.00 (51)	P315-L	M231-02
P315-M232	P315X-M232	P315X-M232E	100 (0.71)	2.23 (57)	3.25 (83)	P315-L	M232-04
P315-M233	P315X-M233	P315X-M233E	150 (1.06)	2.23 (57)	4.00 (102)	P315-L	M233-06
P315-M341	P315X-M341	P315X-M341E	150 (1.06)	3.25 (83)	2.45 (62)	P315-L	M341-06
P315-M342	P315X-M342	P315X-M342E	300 (2.12)	3.25 (83)	3.70 (93)	P315-H	M342-09
P315-M343	P315X-M343	P315X-M343E	450 (3.18)	3.25 (83)	5.31 (135)	P315-H	M343-11
P315-M421	P315X-M421	P315X-M421E	650 (4.59)	4.20 (106)	4.74 (120)	P315-H	M421-12
P315-M422	P315X-M422	P315X-M422E	1100 (7.77)	4.20 (106)	7.00 (178)	P315-H	M422-12
P315-MH232	P315X-MH232	P315X-MH232E	230 (1.62)	2.25 (57)	3.10 (79)	P315-L	MH232-04
P315-MH342	P315X-MH342	P315X-MH342E	650 (4.59)	3.38 (86)	4.77 (121)	P315-P	MH342-10
P315-MH344	P315X-MH344	P315X-MH344E	1150 (8.12)	3.38 (86)	7.62 (194)	P315-P	MH344-11
P315-MH421	P315X-MH421	P315X-MH421E	1200 (8.47)	4.28 (108)	6.20 (158)	P315-P	MH421-11
P315-MH422	P315X-MH422	P315X-MH422E	2400 (16.95)	4.28 (108)	8.63 (219)	P315-P	MH422-16
P315-MH423	P315X-MH423	P315X-MH423E	3600 (25.42)	4.28 (108)	11.15 (248)	P315-P	MH423-16

PACKAGED SYSTEMS

SPEED/FORCE CURVE

* Suffix 'A' - 0.050" Lead; 'C' - 0.250" Lead

