



Typical Applications

- Pick and Place
- Inspection
- Assembly
- Deposition
- Contouring
- Laser Cutting
- Dispensing

General Specifications

Materials	Base and end plates — black anodized aluminum alloy (6061 and cast tool plate); Covers — clear anodized aluminum cast tool plate; Ballscrew and guideways — DIN 1.6523 and 1.3505 steel
Cross Section	152.4mm x 88.9mm (6 inches x 3.5 inches)
Travel Lengths (including limits and covers)	Standard — 152.4mm (6 inches), 304.8mm (12 inches), 457.2mm (18 inches) and 609.6mm (24 inches) Extended — 762.0mm (30 inches), 914.4mm (36 inches), 1066.8mm (42 inches) and 1219.2mm (48 inches) (please refer to Travel Dependent Specifications)
Drive Screw	Preloaded precision ground ballscrew — JIS C3 & C5 (zero backlash) Nominal diameter 20mm (0.7874 inches)
Ballscrew Lead Options	5.08mm (0.2 inches), 10mm (0.3937 inches) or 20mm (0.7874 inches) (please refer to Travel Dependent Specifications for maximum speeds)
Bearings	Matched precision grade recirculating linear guideways Nominal coefficient of friction 0.008 Special high precision assembly option available for standard travels only
Couplings	Bellows, Oldham or Stainless Steel Beam (please refer to Coupling Section)
Motors	Stepper (standard, T or V options) or Servo; Nominal NEMA 23 or NEMA 34 frame size (please refer to Stepper Section G-1, Servo Section H-1 and Motor Section)
Limit Switches	Internal Hall Effect switches — non-adjustable; 3 position or 2 position — normally closed (please refer to Limit Switch Section)
Linear Encoder Resolution	1 micron (0.000039 inches) or 2 microns (0.000079 inches) (please refer to Linear Encoder Section)
Covers	Clear anodized aluminum plate (Nominal IP 30)
Environment	General industrial, clean room or vacuum (please refer to Environmental Section)
Normal Ambient Temperature	20°C ± 15°C (68°F ± 27°F) — special high or low temperature preparation also available
Normal Ambient Pressure	760 torr — 10 ⁻³ torr (standard preparation) — up to 10 ⁻⁷ torr (special preparation)
Normal Cleanliness	Class 1000 (standard preparation) — up to Class 100 (special preparation)
Audible Noise (max.)	70 dB at top speed (1m away from positioning system)
Maximum Input Torque	300 oz-in



Specifications

Global Specifications

Ballscrew Accuracy Tolerances^{1,2}
(maximum lead error tolerance)

Travel of 600mm (24 inches) or less — JIS C3
8 microns per 300mm — 6 microns per revolution
0.00032 inch per foot — 0.00024 inch per revolution

Travel of 600mm (24 inches) or less — JIS C1
5 microns per 300mm — 4 microns per revolution
0.00020 inch per foot — 0.00016 inch per revolution

Travel greater than 600mm (24 inches) — JIS C5
18 microns per 300mm — 8 microns per revolution
0.00072 inch per foot — 0.00032 inch per revolution

Unidirectional Repeatability (max.)^{1,2}
(without linear encoder)

Travel 600mm (24 inches) or less
3 microns (0.00012 inch)

Travel greater than 600mm (24 inches)
4 microns (0.00016 inch)

Bi-directional Repeatability (max.)^{1,2}
(without linear encoder)

Travel 600mm (24 inches) or less
6 microns (0.00024 inch)

Travel Greater than 600mm (24 inches)
8 microns (0.00032 inch)

Limit Switch Repeatability²

50 microns (0.002 inch) (please refer to Limit Switch Section)

Breakaway Torque (max.)²

0.141 Nm (20 oz-in)

Running Torque (max.)²

0.127 Nm (18 oz-in)

Nominal Acceleration (max.)²

2.0 g

Duty Cycle

100%

Normal Load Capacity (max.)^{2,3}

±193 kg(f) (425 lbs.) (please refer to stiffness specifications)

Side Load Capacity (max.)^{2,3}

±141 kg(f) (310 lbs.) (please refer to stiffness specifications)

Axial Load Capacity (max.)^{2,3}

±47 kg(f) (110 lbs.) (please refer to stiffness specifications)

Roll Moment Capacity (max.)^{2,3}

±133 Nm (96 ft-lb) (please refer to stiffness specifications)

Pitch Moment Capacity (max.)^{2,3}

±106 Nm (77.5 ft-lb) (please refer to stiffness specifications)

Yaw Moment Capacity (max.)^{2,3}

±71 Nm (52 ft-lb) (please refer to stiffness specifications)

Nominal Straightness^{2,3}
(horizontal straightness)

2 microns per 25mm (0.00008 inch per inch)
Not to exceed travel dependent specifications

Precision Option
(standard travels only)

1 micron per 25mm (0.00004 inch per inch)
Not to exceed travel dependent specifications

Nominal Flatness^{2,3}
(vertical straightness)

2 microns per 25mm (0.00008 inch per inch)
Not to exceed travel dependent specifications

Precision Option
(standard travels only)

1 micron per 25mm (0.00004 inch per inch)
Not to exceed travel dependent specifications

Normal Load Stiffness^{2,3}

5.5 kg(f) per micron (300,000 lbs. per inch)

Side Load Stiffness^{2,3}

4.0 kg(f) per micron (225,000 lbs. per inch)

Axial Load Stiffness^{2,3}

0.65 kg(f) per micron (35,000 lbs. per inch)

Roll Moment Compliance^{2,3}

0.75 arc-sec per Nm (1 arc-sec per ft-lb)

Pitch Moment Compliance^{2,3}

0.75 arc-sec per Nm (1 arc-sec per ft-lb)

Yaw Moment Compliance^{2,3}

1.5 arc-sec per Nm (2 arc-sec per ft-lb)

Precision X-Y Mounting Orthogonality
(XYP)^{2,3} 15 arc-sec

Moving Mass (carriage and bearing) 2.75 kg(f) (6 lbs.)

1 For applications requiring higher specification, interferometer testing, a higher accuracy ballscrew or a linear encoder may be necessary. Please refer to the Performance Verification Section and the Linear Encoder Section.

2 Please consult IDC if your application requirements exceed catalog specifications.

3 Based on the centerline of the table top.

All specifications are based on ISO 230-2 measurements of an unloaded, bolted down Precision Table with optimized motor tuning. These specifications were generated by measuring the performance of a complete motion system that utilized IDC motors, drives and controls.

Note: IDC accuracy measurements are based on a stable 20°C environment. Thermal variations can affect application results significantly.

**Travel Dependent Specifications****Standard Travels — Precision Assembly Option Available**

	RC6-6	RC6-12	RC6-18	RC6-24
Travel — mm (inches)	152.4 (6)	304.8 (12)	457.2 (18)	609.6 (24)
Accuracy (error max.) — microns (inches)	12 (0.00048)	14 (0.00056)	16 (0.00064)	18 (0.00072)
Inertia — $\text{kgm}^2 \times 10^{-6}$ (oz-in-s ² × 10 ⁻³)	61.7 (8.7)	84.4 (12.0)	107.1 (15.2)	129.8 (18.4)
Total Table Weight (without motors) — kg(f) (lbs.)	10.4 (23)	12.3 (27)	14.1 (31)	15.9 (35)
Top Speed — 5G screw — mm/s (inches/s)	322 (12.7)	322 (12.7)	322 (12.7)	214 (8.5)
Top Speed — 10MG screw — mm/s (inches/s)	635 (25.0)	635 (25.0)	635 (25.0)	422 (16.6)
Top Speed — 20MG screw — mm/s (inches/s)	1270 (50.0)	1270 (50.0)	1270 (50.0)	844 (33.3)
Roll Deviation (max.) ^{2,3} — arc-sec (precision)	16 (8)	18 (9)	20 (10)	24 (12)
Yaw Deviation (max.) ^{2,3} — arc-sec (precision)	16 (8)	18 (9)	20 (10)	24 (12)
Pitch Deviation (max.) ^{2,3} — arc-sec (precision)	16 (8)	18 (9)	20 (10)	24 (12)
Nominal Straightness (max.) ^{2,3} — microns (inches)	12 (0.00048)	16 (0.00064)	20 (0.00080)	24 (0.00096)
Precision Assembly Option	6 (0.00024)	8 (0.00032)	10 (0.00040)	12 (0.00048)
Nominal Flatness (max.) ^{2,3} — microns (inches)	12 (0.00048)	16 (0.00064)	20 (0.00080)	24 (0.00096)
Precision Assembly Option	6 (0.00024)	8 (0.00032)	10 (0.00040)	12 (0.00048)

Extended Travels — Precision Assembly Option Not Available

	RC6-30	RC6-36	RC6-42	RC6-48
Travel — mm (inches)	762.0 (30)	914.4 (36)	1066.8 (42)	1219.2 (48)
Accuracy (error max.) — microns (inches)	24 (0.00096)	28 (0.00112)	32 (0.00128)	36 (0.00144)
Inertia — $\text{kgm}^2 \times 10^{-6}$ (oz-in-s ² × 10 ⁻³)	152.5 (21.6)	175.3 (24.8)	198.0 (28.0)	220.7 (31.3)
Total Table Weight (without motors) — kg(f) (lbs.)	17.7 (39)	19.5 (43)	21.3 (47)	23.1 (51)
Top Speed — 5G screw — mm/s (inches/s)	152 (6.0)	114 (4.5)	88 (3.5)	70 (2.8)
Top Speed — 10MG screw — mm/s (inches/s)	300 (11.8)	223 (8.8)	173 (6.8)	141 (5.5)
Top Speed — 20MG screw — mm/s (inches/s)	599 (23.6)	447 (17.6)	346 (13.6)	276 (10.8)
Roll Deviation (max.) ^{2,3} — arc-sec (precision)	40	45	50	55
Yaw Deviation (max.) ^{2,3} — arc-sec	40	45	50	55
Pitch Deviation (max.) ^{2,3} — arc-sec	40	45	50	55
Nominal Straightness (max.) ^{2,3} — microns (inches)	28 (0.00112)	32 (0.00128)	36 (0.00144)	40 (0.00160)
Nominal Flatness (max.) ^{2,3} — microns (inches)	28 (0.00112)	32 (0.00128)	36 (0.00144)	40 (0.00160)

Ballscrew Data

	Diameter mm (inches)	Efficiency	Direction	Duty Cycle	Contouring Thrust Load (max.) kg(f) (lbs.)
5G	20 (0.7874)	87%	Right Hand	100%	10.0 (22.0)
10MG	20 (0.7874)	90%	Right Hand	100%	7.0 (15.4)
20MG	20 (0.7874)	93%	Right Hand	100%	5.0 (11.0)

Life Calculation Constants (Dynamic Load Capacity)

(please refer to Bearing and Drivescrew Section)

Bearings	640 kg(f)
5G Ballscrew	317 kg(f)
10MG Ballscrew	232 kg(f)
20MG Ballscrew	136 kg(f)

2 Please consult IDC if your application requirements exceed catalog specifications.

3 Based on the centerline of the table top.

Note: IDC accuracy measurements are based on a stable 20°C environment. Thermal variations can affect application results significantly.





Specifications

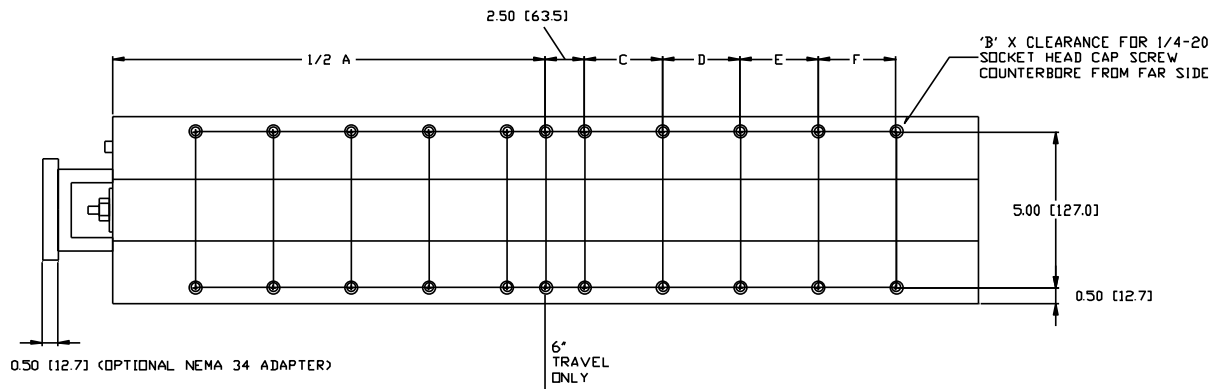
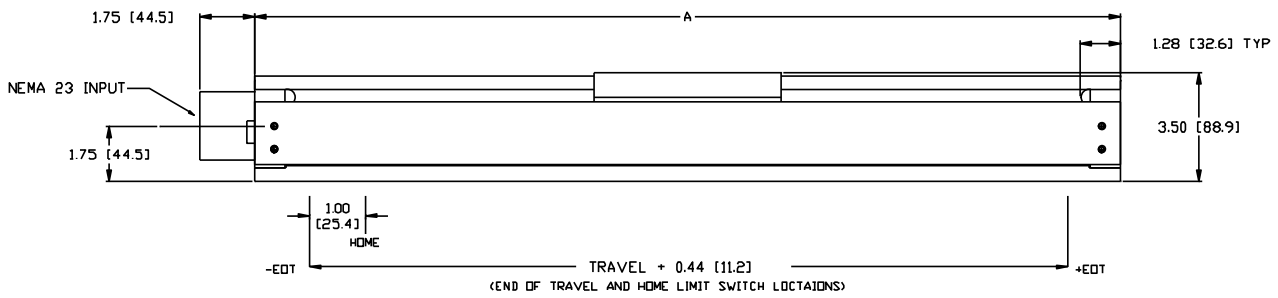
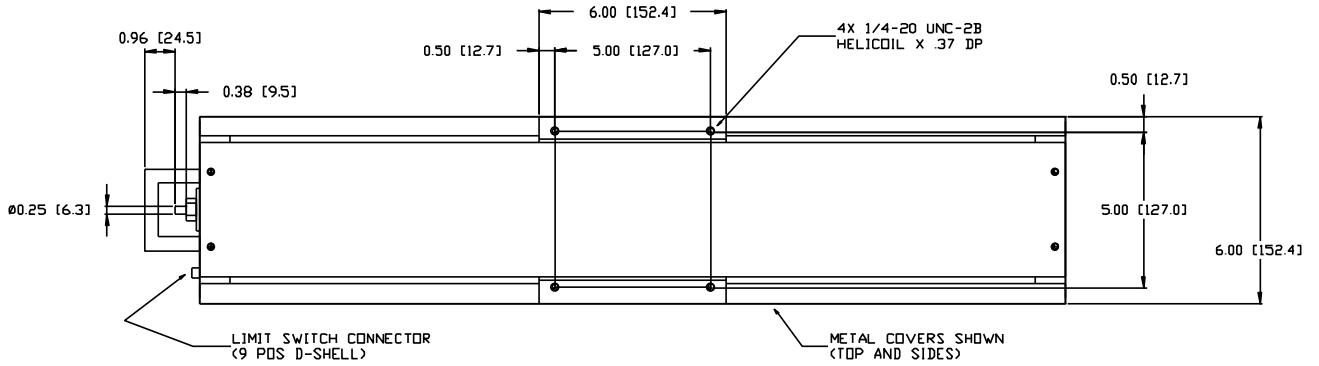

Travel	A	B	C	D	E	F
6.00 (152.4)	15.81 (401.6)	10	2.50 (63.5)	—	—	—
12.00 (304.8)	21.81 (554.0)	8	5.00 (127.0)	—	—	—
18.00 (457.2)	27.81 (706.4)	12	5.00 (127.0)	5.00 (127.0)	—	—
24.00 (609.6)	33.81 (858.8)	12	5.00 (127.0)	5.00 (127.0)	—	—
30.00 (762.0)	39.79 (1010.7)	16	5.00 (127.0)	5.00 (127.0)	5.00 (127.0)	—
36.00 (914.4)	45.79 (1163.1)	16	5.00 (127.0)	5.00 (127.0)	5.00 (127.0)	—
42.00 (1066.8)	51.79 (1315.5)	20	5.00 (127.0)	5.00 (127.0)	5.00 (127.0)	5.00 (127.0)
48.00 (1219.2)	57.79 (1467.9)	20	5.00 (127.0)	5.00 (127.0)	5.00 (127.0)	5.00 (127.0)





Basic Stepper Configuration

RC6-___-5G-OE4-P22T-LI3-E0-CV1

Standard Precision Assembly	High Performance Step Motor (P22T)
Precision Ground Ballscrew (5G)	3 Position Internal Limit Switches (LI3)
Travel (inches) 6, 12, 18, and 24	No Linear Encoder (E0)
0.25 inch Oldham Coupling (OE4)	Neoprene Bellows Covers (CV1)

(please refer to How to Order page for additional standard options)

Basic Servo Configuration

RC6-___-5G-BE4-BN23-LI3-E0-CV1

Standard Precision Assembly	High Performance Servo Motor (BN23)
Precision Ground Ballscrew (5G)	3 Position Internal Limit Switches (LI3)
Travel (inches) 6, 12, 18, and 24	No Linear Encoder (E0)
0.25 inch Bellows Coupling (BE4)	Neoprene Bellows Covers (CV1)

(please refer to How to Order page for additional standard options)

Make it an IDEal System

Include an IDC drive or control that is preconfigured for and tested with each Precision Table axis.

Stepper Choices: NextStep, SmartStep23, SmartStep, S6961 or S6962

Servo Choices: B8001, B8961 or B8962

(order as a separate line item)

Example:

RC6-18-5G-OE4-P22T-LI3-E0-CV1	2
RC6 XYP	1
SMART STEP23	2
IDEAL SYSTEM	2



(please refer to the IDEal System Section for further details)

Standard Multi-Axis Configuration

Standard Precision X-Y Mounting (XYP) — 15 arc-sec Orthogonality — (dowel pinned assembly)

(ordered as a separate line item to assemble 2 separate tables)

Example:

RC6-12-5G-BE4-BN23-LI3-E0-CV1	2
RC6 XYP	1

Carriage to Carriage Mounting (XYC) — 15 arc-sec Orthogonality — (permanent assembly)

(ordered as a separate line item to assemble 2 separate tables)

Example:

RC6-12-5G-BE4-BN23-LI3-E0-CV1	2
RC6 XYC	1

(for applications requiring more complicated assemblies, please refer to the Multi-Axis Section)

Standard Environmental Preparations

All standard IDC precision tables are designed to operate in general industrial environments.

Standard environmental preparation for Class 100 Clean Room or 10⁻⁷ Vacuum environments is also available.

(ordered as a separate line item per axis)

Example:	RC6-18-5G-BE4-BN23-LI3-E0-CV1	2	Example:	RC6-6-5G-BE4-BN23-LI3-E0-CV0	2
	CLEAN 100	2		VACUUM	2
	RC6 XYP	1		RC6 XYP	1

(for applications requiring other non-standard environments, please refer to the Environmental Section)

Performance Verification and Testing

(ordered as separate line item per axis)

Example:

RC6-24-5G-OE4-P22T-LI3-E0-CV1	1
TEST 1-1	1

(for applications requiring testing, please refer to the Performance Verification Section)





How To Order

High Precision—Versatile—Recirculating
Linear Bearing
High Load Capacity
& Throughput

RC6

Ordering Example

RC6	–	6	–	5G	–	OE4	–	P22T	–	LI3	–	E0	–	CV1
Model		Travel		Drive Screw		Coupling		Motor		Limit Switches		Linear Encoder		Covers

Product Model

RC6	Standard Assembly
RC6P	Precision Assembly (lower angular errors) (Standard travels only)

Travel (Inches)

6, 12, 18, 24, 30, 36, 42, 48

Drive Screws (see Drive Screw Section)

5G	5.08mm (0.2 inch) JIS C3 Precision Ground Ballscrew Preloaded — Zero Backlash (JIS C5 for travel over 24 inches)
10MG	10mm (0.3937 Inch) JIS C3 Precision Ground Ballscrew Preloaded — Zero Backlash (JIS C5 for travel over 24 inches)
20MG	20mm (0.7874 Inch) JIS C3 Precision Ground Ballscrew Preloaded — Zero Backlash (JIS C5 for travel over 24 inches)
5GP	5.08mm (0.2 inch) JIS C1 Precision Ground Ballscrew Preloaded — Zero Backlash (JIS C5 for travel over 24 inches)
10MGP	10mm (0.3937 Inch) JIS C1 Precision Ground Ballscrew Preloaded — Zero Backlash (JIS C5 for travel over 24 inches)
20MGP	20mm (0.7874 Inch) JIS C1 Precision Ground Ballscrew Preloaded — Zero Backlash (JIS C5 for travel over 24 inches)

Coupling — Type and Input Shaft (see Coupling Section)

BE4	Stainless Steel Bellows 0.25 inch shaft diameter
BE5	Stainless Steel Bellows 0.3125 inch shaft diameter
BE6	Stainless Steel Bellows 0.375 inch shaft diameter
OE4	Oldham 0.25 inch shaft diameter
OE5	Oldham 0.3125 inch shaft diameter
OE6	Oldham 0.375 inch shaft diameter
SE4	Stainless Steel Beam 0.25 inch shaft diameter
SE5	Stainless Steel Beam 0.3125 inch shaft diameter
SE6	Stainless Steel Beam 0.375 inch shaft diameter

Motors — Stepper (see Stepper Section on page G-1 and Motor Section)

P21n	Performance NEMA 23 (0.25 inch coupling)
P22n	Performance NEMA 23 (0.25 inch coupling)
S21n	Standard NEMA 23 (0.25 inch coupling)
S22n	Standard NEMA 23 (0.25 inch coupling)
S23n	Standard NEMA 23 (0.25 inch coupling)
S32n	Standard NEMA 34 (0.375 inch coupling)
S33n	Standard NEMA 34 (0.375 inch coupling)
n = T (Series), V (Parallel), N (Flying leads)	

Motors — Servo (see Servo Section on page H-1 and Motor Section)

BN21	Performance NEMA 23 (0.25 inch coupling)
BN23	Performance NEMA 23 (0.25 inch coupling)
B22	Standard NEMA 23 (0.3125 inch coupling)
B23	Standard NEMA 23 (0.3125 inch coupling)
B23H	Standard NEMA 23 (0.3125 inch coupling)
BN31	Performance NEMA 34 (0.375 inch coupling)
BN32	Performance NEMA 34 (0.375 inch coupling)

Motors — Customer Supplied (see Motor Section)

X23n	Standard NEMA 23 Motor Mount
X34n	Standard NEMA 34 Motor Mount
n = X Customer Supplied and Mounted	
n = C Customer Supplied and IDC Mounted	

Limit Switches (see Limit Switch Section)

L0	No Limit Switch
LI2	2 Position Internal Hall Effect Limit Switch (2 over travel limit switches)
LI3	3 Position Internal Hall Effect Limit Switch (2 over travel limits & 1 home limit switch)

Encoders (see Linear Encoder Section)

E0	No Linear Encoder
EM1	1 Micron Resolution
EM2	2 Micron Resolution
EMR	Standard Motor Mounted Rotary Encoder
EMKR	1000 Line Encoder (where available)

Covers (see Cover Section)

CV0	No Covers
CV1	Aluminum Plate Covers

Special Features (see preceding page)

(ordered as a separate line item)

Please contact IDC for non-standard applications or components.

Lead-times for complete positioning systems are determined by the lead-times of the individual components (precision tables, motors, gearmotors, drives and controls, etc.). Standard precision table lead-times apply to basic configurations and standard catalog options. Extended travels, environmental preparations, special components, special testing, special modifications and custom systems may require additional lead-time. Please contact IDC for further details.

Precision Positioning Tables