

AKD[®] Near Servo Drive

Installation Manual



Edition: M, October 2021

Valid for AKD-N, Hardware Revision C

Part Number 903-200018-00

Original Document



For safe and proper use, follow these instructions. Keep for future use.



Functional
Safety
Type
Approved

www.tuv.com
ID 060000000



KOLLMORGEN

Record of document revisions

Revision	Remarks
...	Table with lifecycle information of this document see (→ # 81)
K, 10/2018	Layout of the warning notes updated, user expertise updated, new readers note cover page, wording AKD-N/IP67 environment note
L, 10/2019	EAC, RoHS, AKM2G cable note
M, 10/2021	X5 thermal sensor usage updated, notes for MKD-C power supply, STO input current corrected, Hardware Revision C, package supplied (Safety Notes), chapter "Approvals" restructured, PFH values updated

Hardware Revision (HR)

AKD-N	AKD-C	Firmware/ WorkBench	Export Classification	Remarks
A	A	from 1.11	3A225	AKD-C and AKD-N start revisions
B	A	from 1.13	-	AKD-N Hardware Revision for export classification traceability purposes
C	A	from 1.19	-	AKD-N usable for MKD-C for extended string size

Trademarks

- AKD is a registered trademark of Kollmorgen Corporation.
- EnDat is a registered trademark of Dr. Johannes Heidenhain GmbH.
- EtherCAT® is a registered trademark and patented technology, licensed by Beckhoff Automation GmbH, Germany.
- HIPERFACE is a registered trademark of Max Stegmann GmbH.
- SpeedTec is a registered trademark of TE Connectivity Industrial GmbH.
- Windows is a registered trademark of Microsoft Corporation.

Current patents

- US Patent 8.154.228 (Dynamic Braking For Electric Motors)
- US Patent 8.214.063 (Auto-tune of a Control System Based on Frequency Response)
- US Patent 8.566.415 (Safe Torque Off over network wiring)
- US Patent 9.634.863 (Patent Systems and methods for supporting two different protocols on a same physical connection)
- US Patent 10.374.468 (System and method for improved DC power line communication)

Patents referring to fieldbus functions are listed in the matching fieldbus manual.

Technical changes which improve the performance of the device may be made without prior notice!

This document is the intellectual property of Kollmorgen. All rights reserved. No part of this work may be reproduced in any form (by photocopying, microfilm or any other method) or stored, processed, copied or distributed by electronic means without the written permission of Kollmorgen.

1 Table of Contents

1 Table of Contents	3
2 General	7
2.1 About this Manual	8
2.2 Using the PDF Format	8
2.3 Notes for the Printed Edition (paper version)	8
2.4 Symbols Used	9
2.5 Abbreviations Used	9
3 Product Safety	10
3.1 You should pay attention to this	11
3.2 Use as Directed	13
3.3 Prohibited Use	14
3.4 Warning notes placed on the product	14
4 Product life cycle handling	15
4.1 Packaging	16
4.2 Transport	16
4.3 Storage	16
4.4 Installation, setup and normal operation	17
4.5 Decommissioning	17
4.5.1 Volatile and non-volatile memory	17
4.6 Maintenance and cleaning	17
4.7 Disassembly	17
4.8 System Repair	18
4.9 Disposal	18
5 Approvals	19
5.1 Conformance with EC Machinery Directive, Functional Safety	20
5.2 Conformance with EC Low Voltage and EMC Directives	20
5.3 Conformance with UL/cUL	21
5.3.1 UL Markings / Marquages UL	21
5.4 Conformance with EAC	22
5.5 Conformance with RoHS	22
5.6 Conformance with REACH	22
6 Package	23
6.1 Package Supplied	24
6.2 Nameplate	24
6.3 Part Number Scheme	25
7 Technical description and data	26
7.1 The AKD-N Family of Digital Drives	27
7.2 Mechanical Data	28
7.3 Electrical Data	28
7.4 Performance Data	28
7.5 Ambient Conditions, Ventilation, and Mounting Position	29
7.6 Inputs/Outputs	29
7.7 Connectors	30
7.8 Cable Requirements	31
7.9 Cable length definition	32
7.10 Regen circuit	33
7.10.1 Functional description	33
7.10.2 Technical data	33
7.11 LED Codes	34
7.12 Switch-On and Switch-Off Behavior	35

7.12.1	Switch-on behavior in standard operation	35
7.12.2	Switch-off behavior	36
7.12.2.1	Switch-off behavior using a digital input (controlled stop)	36
7.12.2.2	Switch-off behavior using the DRV.DIS command	37
7.12.2.3	Switch-off behavior using HW Enable input on AKD-C (uncontrolled stop)	38
7.12.2.4	Switch-off behavior in the event of a fault	39
7.13	Safe Torque Off (STO)	42
7.13.1	Global STO, control via AKD-C	42
7.13.2	Global STO, control via MKD-C	42
7.13.3	Local STO, control via digital input on AKD-N-DS/DT	42
7.13.4	Safety characteristic data	43
7.13.5	Use as directed	43
7.13.6	Prohibited use	43
7.13.7	Response Time	44
7.13.8	Enclosure, wiring	44
7.13.9	Local STO safety instructions	45
7.13.10	Technical data and pinout local STO	46
7.13.11	Functional description local STO	47
7.13.11.1	Signal diagram (sequence)	47
7.13.12	Functional test	48
7.13.12.1	Global STO	48
7.13.12.2	Local STO	48
7.13.12.3	Local STO application example	49
7.13.12.4	OSSD test pulses	49
8	Mechanical Installation	50
8.1	Important Notes	51
8.2	Temperature Management	51
8.3	Mechanical Drawings	52
8.3.1	Dimensions AKD-N, preferred mounting	52
8.3.2	Dimensions AKD-N with optional heat sink, preferred mounting	53
9	Electrical Installation	54
9.1	Important Notes	55
9.2	Guide to Electrical Installation	56
9.3	System Topology of a Decentralized Servo System	57
9.3.1	System limits	57
9.3.2	Example with AKD-C	57
9.3.3	Example with MKD-C	58
9.4	Wiring	59
9.5	Connection Overview	60
9.5.1	Connector assignment AKD-Nzzz07-DB	60
9.5.2	Connector assignment AKD-Nzzz07-DG/DT	60
9.5.3	Connector assignment AKD-Nzzz07-DF/DS	61
9.5.4	Connection diagram with MKD-C	62
9.5.5	Connection diagram AKD-Nzzz07-DB with AKD-C	62
9.5.6	Connection diagram AKD-Nzzz07-DG/DT with AKD-C	63
9.5.7	Connection diagram AKD-Nzzz07-DF/DS with AKD-C	64
9.6	Hybrid Connection (X1, X2)	65
9.7	I/O Connection (X3)	65
9.7.1	Digital Inputs	66
9.7.2	Digital Output	67
9.8	Motor Power Connection (X4)	68
9.8.1	Connector X4 AKD-Nzzz07 all variants, hybrid, single cable	68
9.8.2	Connector X4 AKD-Nzzz07-DF/DS, dual cables	68
9.9	Motor Brake Connection (X4)	69

9.10 Motor Feedback Connection (X4, X5)	71
9.10.1 Connector X4 AKD-Nzzz07 all variants, hybrid, single cable	71
9.10.2 Connector X5 AKD-Nzzz07-DF/DS, dual cable	72
9.11 Optional Connector (X6)	73
9.11.1 Pinout AKD-Nzzz07-DF/DG	73
9.11.2 Pinout AKD-Nzzz07-DS/DT	73
10 Setup	74
10.1 Important Notes	75
10.2 WorkBench Installation	76
10.3 Initial System Test	77
10.3.1 Unpacking, mounting, and wiring	77
10.3.2 Set IP address	77
10.3.3 Confirm connections	77
10.3.4 Install and start WorkBench	78
10.3.5 Enable the drive using the setup wizard	78
10.4 Fault and Warning Messages	78
11 Index	79
12 Record of document revisions	81

---/---

2 General

2.1 About this Manual	8
2.2 Using the PDF Format	8
2.3 Notes for the Printed Edition (paper version)	8
2.4 Symbols Used	9
2.5 Abbreviations Used	9

2.1 About this Manual

This manual, *AKD-N Installation Manual* ("Instructions Manual" according to EC Machinery Directive 2006/42/EU), describes the AKD-N series of digital drives and includes information needed to safely install an AKD-N. A digital version of this manual (pdf format) is available on the DVD included with your drive. Manual updates can be downloaded from the Kollmorgen website (www.kollmorgen.com).

AKD-N information for use consists of:

- *AKD-N Installation Manual*: describes the AKD-N series of digital drives and includes information needed to safely install an AKD-N.
- *Project Guide Decentralized Drive System*: describes how to build a decentralized drive system with AKD-C and AKD-N. It provides tips for system topology, cooling, and maximizing the system performance.
- *AKD-C Installation Manual*: describes the AKD-C series of intelligent power supply for Kollmorgen decentralized drive system and includes information needed for safe assembling, installation and system setup.
- *MKD-C Multi Axes Installation Manual*: describes the MKD drive system modules MKD-C power supply and MKD-N servo drive and includes information needed for safe assembling, installation and system setup.
- *WorkBench Online Help*: describes how to use your drive in common applications. It also provides tips for maximizing your system performance. The *Online Help* includes the *Parameter and Command Reference Guide* which provides documentation for the parameters and commands used to program the drive.
- *EtherCAT Communication*: describes how to use your system in EtherCAT applications.
- *Accessories Manual*: it provides documentation for accessories like cables and regen resistors used with AKD-C and AKD-N. Regional variants of this manual exist.

2.2 Using the PDF Format

This document includes several features for ease of navigation

Cross References	Table of contents and index include active cross references.
Table of contents and index	Lines are active cross references. Click on the line and the appropriate page is accessed.
Page/chapter numbers in the text	Page/chapter numbers with cross references are active links.









2.3 Notes for the Printed Edition (paper version)

A printed version of the manual is enclosed with each product. For environmental reasons, the document was reduced in size and printed on DIN A5.

NOTE

Should you experience difficulties reading the font size of the scaled-down printed version, you can print and use the PDF version in DIN A4 format 1:1. You can find the PDF version on the DVD accompanying the product and on the Kollmorgen website.

2.4 Symbols Used

Symbol	Indication
 DANGER	Indicates a hazardous situation which, if not avoided, will result in death or serious injury.
 WARNING	Indicates a hazardous situation which, if not avoided, could result in death or serious injury.
 CAUTION	Indicates a hazardous situation which, if not avoided, could result in minor or moderate injury.
NOTICE	Indicates situations which, if not avoided, could result in property damage.
NOTE	This symbol indicates important notes.
	Warning of a danger (general). The type of danger is specified by the text next to the symbol.
	Warning of danger from electricity and its effects.
	Warning of danger from hot surface.
	Warning of danger from suspended loads.
	Warning of danger from automatic start.

2.5 Abbreviations Used

Abbreviation	Meaning
(→ # 53)	"see page 53" in this document
CE	Communauté Européenne
EMC	Electromagnetic compatibility
LED	Light-emitting diode
OSSD	Output signals Switching Device
PC	Personal computer
PE	Protective earth
PELV	Protective extra low voltage
PLC	Programmable logic control
PWM	Pulse-width modulation
RAM	Random access memory (volatile memory)
ROD	Incremental encoder (A quad B)
Rth	Specific thermal resistance
SELV	Safety Extra Low Voltage
STO	Safe torque off
VAC	Volts, alternating current
VDC	Volts, direct current

3 Product Safety

To avoid possible damage, read and follow the instructions.

3.1 You should pay attention to this	11
3.2 Use as Directed	13
3.3 Prohibited Use	14
3.4 Warning notes placed on the product	14

3.1 You should pay attention to this

This section helps you to recognize and avoid dangers to people and objects.

Specialist staff required!

The devices are intended for industrial applications. Machine builders must employ qualified personnel. Qualified personnel are people who have been trained to transport, install, commission and operate electrical drives.

- Transport, storage, unpacking: only by personnel with knowledge of handling electrostatically sensitive components.
- Mechanical installation: only by personnel with mechanical expertise.
- Electrical installation: only by personnel with expertise in electrical engineering.
- Basic tests / setup: only by personnel with expertise in electrical engineering and drive technology.

The qualified personnel must know and observe ISO 12100 / IEC 60364 / IEC 60664 and national accident prevention regulations.

Read the documentation!

Read the available documentation before installation and commissioning. Improper handling of the devices can cause harm to people or damage to property. The operator of systems using the drive system must ensure that all personnel who work with the drive read and understand the manual before using the drive.

Check Hardware Revision!

Check the Hardware Revision Number of the product (see product label). This number is the link between your product and the manual. The product Hardware Revision Number must match the Hardware Revision Number on the cover page of the manual.

Pay attention to the technical data!

Adhere to the technical data and the specifications on connection conditions. If permissible voltage values or current values are exceeded, the devices can be damaged. Unsuitable motor or wrong wiring will damage the system components. Check the combination of drive and motor. Compare the rated voltage and current of the units.

Perform a risk assessment!

The manufacturer of the machine must generate a risk assessment for the machine, and take appropriate measures to ensure that unforeseen movements cannot cause injury or damage to any person or property. Additional requirements on specialist staff may also result from the risk assessment.

Automatic Restart!



The drive might restart automatically after power on, voltage dip or interruption of the supply voltage, depending on the parameter setting.

Risk of death or serious injury for humans working in the machine.

If the parameter DRV.ENDEFAULT is set to 1, then place a warning sign to the machine (Warning: Automatic Restart at Power On) and ensure, that power on is not possible, while humans are in a dangerous zone of the machine. In case of using an undervoltage protection device, you must observe EN 60204-1:2006 chapter 7.5 .

Observe electrostatically sensitive components!

The devices contain electrostatically sensitive components which may be damaged by incorrect handling. Electrostatically discharge your body before touching the device. Avoid contact with highly insulating materials (artificial fabrics, plastic film etc.). Place the device on a conductive surface.



Hot surface!

Drives may have hot surfaces during operation. The housing can reach temperatures above 80°C. Risk of minor burns! Measure the temperature, and wait until the housing has cooled down below 40 °C before touching it.



Earthing!

It is vital that you ensure that the drive is safely earthed to the PE (protective earth) busbar in the switch cabinet. Risk of electric shock. Without low-resistance earthing no personal protection can be guaranteed.

Leakage Current!

Since the leakage current to PE is more than 3.5 mA, in compliance with IEC61800-5-1 the PE connection must either be doubled or a connecting cable with a cross-section >10 mm² must be used. Deviating measures according to regional standards might be possible.



High voltages!

The equipment produces high electric voltages up to 900 V. Do not open or touch the equipment during operation. Keep all covers closed. The built-in LED does **not** safely indicate the real voltage level.

During operation, drives may have uncovered live sections, according to their level of enclosure protection. Wait at least 7 minutes after disconnecting the drive from the main supply power before touching potentially live sections of the equipment (such as contacts) or removing any connections.

Capacitors can have dangerous voltages present up to 7 minutes after switching off the supply power. Always measure the voltage in the DC bus link at connector X14 at AKD-C respectively X23 at MKD-C and wait until the voltage is below 50 V before handling components.

Never undo any electrical connections to the drive while it is live. There is a danger of electrical arcing with damage to contacts and personal injury.

Reinforced Insulation

Thermal sensors, motor holding brakes and feedback systems built into the connected motor must have reinforced insulation (according to IEC61800-5-1) against system components with power voltage, according to the required application test voltage. All Kollmorgen components meet these requirements.

Functional Safety

The STO safety implementation on the AKD is certified. The assessment of the safety functions according to EN13849 or EN 62061 must finally be done by the user. Serious injury could result when a suspended load is not properly blocked. Functional safety requires an additional, external mechanical brake, operated by a safety controller.

Never modify the drive!

It is not allowed to modify the drive hardware without permission by the manufacturer. Opening the housing causes loss of warranty.

3.2 Use as Directed

The AKD-N family of drives is exclusively intended for driving suitable synchronous servomotors with closed-loop control of torque, speed, and/or position.

Drives are components that are built into electrical plants or machines and can only be operated as integral components of these plants or machines. The manufacturer of the machine must generate a risk assessment for the machine.

When the drives are built into machines or plant, the drive must not be used until it has been established that the machine or plant fulfills the requirements of the regional directives.

Kollmorgen Decentralized Drive System

AKD-N series drives must only be operated in a motion system with components from Kollmorgen. Required additional Kollmorgen components are the intelligent power supply AKD-C or MKD-C, hybrid cables, motor power and feedback cables, servomotors.

Assembling

AKD-N drives must only be operated in machines suitable for the ambient conditions defined on (→ # 29). Optional finned heat sink may be necessary to keep the drive flange temperature below 85 °C and enable the axis to operate with maximum power. Observe the information given in the Decentral System Project Guide.

Guide.

Wiring

Use only Kollmorgen CCNxN1 series of hybrid cables for connecting AKD-N and AKD-C devices. For connecting AKD-N to MKD-C devices use MKC-HYB-z-AKN cable only.

Power supply

AKD-N series drives must be powered by AKD-C or MKD-C intelligent power supplies with DC voltage from 55 VDC up to 800 VDC.

Motor voltage rating

The rated voltage of the motors must be at least as high as the DC bus link voltage divided by $\sqrt{2}$ produced by the drive ($U_{nMotor} \geq U_{DC}/\sqrt{2}$).

Safe torque off

Review the section "Use as Directed" in the STO chapter (→ # 42) before using this safety function (SIL2, PLd, category 3 according to ISO 13849).

The 24 VDC supply unit for local STO supply must accord to PELV (EN 60204-1) requirements.

3.3 Prohibited Use

Other use than that described in chapter “Use as directed” is not intended and can lead to personnel injuries and equipment damage.

The device may not be used

- with a machine that does not comply with appropriate national directives or standards,
- for driving elevators,
- in ships or offshore applications,
- in applications with continuous, operational short circuits to the motor power contacts.

The use of the device in the following environments is also prohibited:

- potentially explosive areas,
- environments with corrosive and/or electrically conductive acids, alkaline solutions, oils, vapors, dusts.

Wiring the system with hybrid cables from other manufacturers than Kollmorgen is not allowed. Changing Kollmorgen cables or connectors is not allowed.

3.4 Warning notes placed on the product

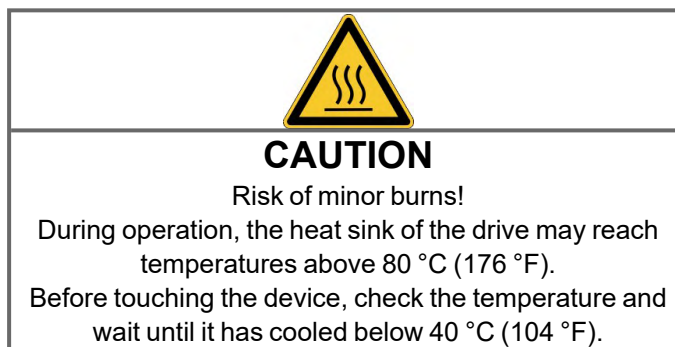

NOTICE

If these signs are damaged, they must be replaced immediately.

4 Product life cycle handling

4.1 Packaging	16
4.2 Transport	16
4.3 Storage	16
4.4 Installation, setup and normal operation	17
4.5 Decommissioning	17
4.6 Maintenance and cleaning	17
4.7 Disassembly	17
4.8 System Repair	18
4.9 Disposal	18

4.1 Packaging

The AKD-N packaging consists of recyclable cardboard with inserts and a label on the outside of the box.

Model	Package Dimensions (mm) HxWxL	Total Weight (kg)
AKD-N00307	120 x 295 x 370	3.2
AKD-N00607	120 x 295 x 370	3.2
AKD-N01207	125 x 410 x 295	approx. 3.5

4.2 Transport

Transport the AKD-N in accordance with IEC 61800-2 as follows:

- Transport only by qualified personnel in the manufacturer's original recyclable packaging.
- Avoid shocks while transporting.
- Store at or below maximum stacking height of 8 cartons
- Transport only within specified temperature ranges: -25 to +70 °C, max. rate of change 20 K/hour, class 2K3.
- Transport only within specified humidity: maximum 95% relative humidity, no condensation, class 2K3.

NOTICE

The drives contain electrostatically sensitive components that can be damaged by incorrect handling. Electrostatically discharge yourself before touching the drive. Avoid contact with highly insulating materials, such as artificial fabrics and plastic films. Place the drive on a conductive surface.

If the packaging is damaged, check the unit for visible damage. Inform the shipper and the manufacturer of any damage to the package or product.

4.3 Storage

Store the AKD-N in accordance with IEC 61800-2 as follows:

- Store only in the manufacturer's original recyclable packaging.
- Store at or below maximum stacking height of 8 cartons
- Store only within specified temperature ranges: -25 to +55 °C, max. rate of change 20 K/hour, class 1K4.
- Storage only within specified humidity: 5 to 95% relative humidity, no condensation, class 1K3.

4.4 Installation, setup and normal operation

Installation and setup information are given in this manual:

- Mechanical installation (→ # 50)
- Electrical installation (→ # 54)
- Setup (→ # 74)

Normal operation tested for environmental class 3K3 according to IEC 61800-2 (→ # 29). The manufacturer of the machine defines the necessary end user expertise based on the risk assessment for the machine and describes the requirements for normal operation based on the application.

4.5 Decommissioning

NOTICE

Only professional staff who are qualified in electrical engineering are allowed to decommission parts of the system.

DANGER: Lethal Voltages!

There is a danger of serious personal injury or death by electrical shock or electrical arcing.

- Switch off the main switch of the switchgear cabinet.
- Secure the system against restarting.
- Block the main switch.
- Wait at least 7 minutes after disconnecting.

4.5.1 Volatile and non-volatile memory

[Letter of Volatility for AKD Drives](#): This letter of volatility describes volatile and non-volatile media as well as storage media on the AKD. Customers can use this document to comply with security requirements.

4.6 Maintenance and cleaning

The device does not require maintenance, it should be inspected once a year by professional staff.

NOTICE

Do not immerse or spray the device. Avoid that liquid enters the device. The inside of the unit can only be cleaned by the manufacturer. Opening the device voids the warranty.

To clean the device exterior:

1. Decommission the device (see chapter 4.5 "Decommissioning").
2. Casing: Clean with Isopropanol or similar cleaning solution.

Caution : Highly Flammable! Risk of injury by explosion and fire.

- Observe the safety notes given on the cleaning liquid package.
- Wait at least 30 minutes after cleaning before putting the device back into operation.

4.7 Disassembly

NOTICE

Only professional staff who are qualified in electrical engineering are allowed to disassemble parts of the system.

1. Decommission the device (see chapter 4.5 "Decommissioning").
2. Check temperature.

CAUTION: High Temperature! Risk of minor burns. During operation, the heat sink of the drive may reach temperatures above 80 °C (176 °F). Before touching the device, check the temperature and wait until it has cooled below 40 °C (104 °F).

3. Remove the connectors. Disconnect the potential earth connection last.
4. Demount: loosen the fastening screws. Remove the device.

4.8 System Repair

NOTICE

Only professional staff who are qualified in electrical engineering are allowed to exchange parts of the drive system.

CAUTION: Automatic Start! During replacement work a combination of hazards and multiple episodes may occur.

- Work on the electrical installation may only be performed by trained and qualified personnel, in compliance with the regulations for safety at work, and only with use of prescribed personal safety equipment.

Exchange of the device

Only the manufacturer can repair the device. Opening the device voids the warranty.

1. Decommission the device (see chapter 4.5 "Decommissioning").
2. Demount the device (see chapter 4.7 "Disassembly").
3. Send the device to the manufacturer.
4. Install a new device as described in the Installation Manual.
5. Setup the system as described in the Installation Manual.

Exchange of other drive system parts

If parts of the drive system (for example cables) must be replaced, proceed as follows:

1. Decommission the device (see chapter 4.5 "Decommissioning").
2. Exchange the parts.
3. Check all connections for correct fastening.
4. Setup the system as described in the Installation Manual.

4.9 Disposal

NOTICE

To dispose the unit properly, contact a certified electronic scrap disposal merchant.

In accordance with the WEEE-2012/19/EU guideline and similar, the manufacturer accepts returns of old devices and accessories for professional disposal. Transport costs are the responsibility of the sender.

Send the devices in the original packaging to the manufacturer address:

North America	South America
KOLLMORGEN 201 West Rock Road Radford, VA 24141, USA	KOLLMORGEN Avenida João Paulo Ablas, 2970 Jardim da Glória, Cotia – SP CEP 06711-250, Brazil
Europe	Asia
KOLLMORGEN Europe GmbH Pempelfurtstr. 1 40880 Ratingen, Germany	KOLLMORGEN Room 302, Building 5, Lihpao Plaza, 88 Shenbin Road, Minhang District, Shanghai, China.

5 Approvals

5.1	Conformance with EC Machinery Directive, Functional Safety	20
5.2	Conformance with EC Low Voltage and EMC Directives	20
5.3	Conformance with UL/cUL	21
5.4	Conformance with EAC	22
5.5	Conformance with RoHS	22
5.6	Conformance with REACH	22

5.1 Conformance with EC Machinery Directive, Functional Safety

Conformance with the EC Machinery Directive 2006/42/EU is mandatory for the supply of safety components within the European Community. The STO safety implementation on the AKD is certified by TÜV. The safety circuit implementation used for the safety function "Safe Torque Off" in the drives is suited for SIL 2 according to IEC 62061 and PLd / CAT3 according to ISO 13849-1.

Safe Torque Off (STO) string type (global)

Structure	STO	ISO 13849-1	MTTF _d	IEC 62061	PFH [1/h]	SFF [%]	T _M [Years]
AKD-C + 1 x AKD-N	global	PL d, CAT 3	≥ 100	SIL 2	2.99E-08	97.08	20
AKD-C + 8 x AKD-N	global	PL d, CAT 3	≥ 100	SIL 2	3.07E-08	99.44	20
MKD-C+ 14 x AKD-N	global	PL d, CAT 3	≥ 100	SIL 2	1.86E-08	94.2	20

See installation manuals for *AKD-C / MKD-C* for detailed information.

Safe Torque Off (STO) single drive type (local)

Structure	STO	ISO 13849-1	MTTF _d	IEC 62061	PFH [1/h]	SFF [%]	T _M [Years]
1 x AKD-N-DS/DT	local	PL d, CAT 3	≥ 100	SIL 2	2.9E-08	97.12	20

5.2 Conformance with EC Low Voltage and EMC Directives

EU Declarations of Conformity can be found on the [Kollmorgen website](#).

Conformance with the EC EMC Directive 2014/30/EU and the Low Voltage Directive 2014/35/EU is mandatory for the supply of drives within the European Community.

The drives have been tested by an authorized testing laboratory in a defined configuration, using the system components that are described in this documentation. Any divergence from the configuration and installation described in this documentation means that the user will be responsible for carrying out new measurements to ensure conformance with regulatory requirements.

The AKD-Nzzz07 meet the noise immunity requirements to the 2nd environmental category (industrial environment). For noise emission the AKD-Nzzz07 meet the requirement to a product of the Category C2 (motor cable up to 5 m).

NOTICE

These devices can cause high-frequency interferences in non industrial environments and may require measures for interference suppression (such as additional external EMC filters).

5.3 Conformance with UL/cUL

This drive is listed under UL (Underwriters Laboratories Inc.) file number **E217428**. UL Markings are combined for both AKD-C and AKD-N in one section.

5.3.1 UL Markings / Marquages UL

English	Français
<ul style="list-style-type: none"> This product is suitable for use on a circuit capable of delivering not more than 42,000 rms symmetrical amperes, 480 V maximum. 	<ul style="list-style-type: none"> <i>Ce produit est conçu pour une utilisation sur un circuit capable de fournir 42.000 ampères symétriques (rms) maximum pour 480 V maximum.</i>
<ul style="list-style-type: none"> Maximum surrounding air temperature 40°C. 	<ul style="list-style-type: none"> <i>La température maximale de l'air ambiant de 40°C.</i>
<ul style="list-style-type: none"> AKD-C are intended to be used in a pollution degree 2 environment. 	<ul style="list-style-type: none"> <i>AKD-C sont prévus pour une utilisation dans un environnement de pollution de niveau 2.</i>
<ul style="list-style-type: none"> AKD-C : Use 60/75°C copper wire only. 	<ul style="list-style-type: none"> <i>AKD-C: Utilisez seulement un fil cuivre 60/75°C.</i>
<ul style="list-style-type: none"> AKD-C : CAUTION Risk of Electrical Shock! Capacitors can have dangerous voltages present up to 7 minutes after switching off the supply power. For increased safety, measure the voltage in the DC bus link and wait until the voltage is below 50 V. 	<ul style="list-style-type: none"> AKD-C : ATTENTION: Risque de choc électrique! Des tensions dangereuses peuvent persister dans les condensateurs jusqu'à 7 minutes après la mise hors tension. Pour plus de sécurité, mesurez la tension dans la liaison de bus CC et attendez qu'elle soit inférieure à 50 V.
<ul style="list-style-type: none"> For use in Canada: Transient surge suppression shall be installed on the line side of this equipment and shall be rated 277 V (phase to ground), 480 V (phase to phase), suitable for overvoltage category III, and shall provide protection for a rated impulse withstand voltage peak of 2 kV. 	<ul style="list-style-type: none"> <i>Pour utilisation au Canada: Suppression de surtension transitoire doit être installé sur le côté de la ligne de ce matériel et doit être évalué 277 V (phase à terre) , 480 V (entre phases) , adapté à la catégorie de surtension III , et doit fournir une protection pour un choc nominale supporter la tension de crête de 2 kV.</i>

- The following fuse types are recommended for branch circuit protection for AKD-C01007-CBXX:
Les types de fusibles suivants sont recommandés pour protection de secteur pour AKD-C01007-CBXX:

Model/ Modèle	Class/ Classe	Voltage Rating/ Niveau de tension	Max. Fuse&SCC Rating/ Niveau maximum & SCC
Nonrenewable Cartridge fuse	CC, J	600 VAC	20 A, 200 kA

- The following table illustrates the torque requirements for the field wiring connectors :
Le tableau suivant indique les spécifications de couple pour les connecteurs de câblage sur site:

Model/Modèle	Torque/Couple serrage, LB IN (Nm)	Wire size/Section de fil, AWG (mm ²)
AKD-C X12	6.2 - 7.1 (0.7 - 0.8)	12 - 8 (4 - 10)
AKD-C X20A	6.2 - 7.1 (0.7 - 0.8)	12 - 8 (4 - 10)
AKD-C X21A	6.2 - 7.1 (0.7 - 0.8)	12 - 8 (4 - 10)
AKD-C X14	6.2 - 7.1 (0.7 - 0.8)	12 - 8 (4 - 10)
AKD-C X13	1.8 - 2.2 (0.2 - 0.25)	14 - 12 (2.5 - 4)
AKD-C X15	1.8 - 2.2 (0.2 - 0.25)	20 - 18 (0.5 - 0.8)
AKD-C X16	1.8 - 2.2 (0.2 - 0.25)	20 - 18 (0.5 - 0.8)

- Split gage of AKD-N screwed connectors: max. 2.8 mm.
Le gage de split des connecteurs vissé d'AKD-N: 2,8 mm max.
- Cold plate for AKD-N: at 40°C surrounding air temperature and 680 VDC supply voltage:
Plaque froide pour AKD-N: à température ambiante 40°C et tension d'alimentation 680 VDC:
 - AKD-N00307: 240 mm x 240 mm x 10 mm or equivalent (LxWxT, Aluminum cold plate, uncoated)
 - AKD-N00607: 500 mm x 500 mm x 10 mm or equivalent (LxWxT, Aluminum cold plate, uncoated)
 - AKD-N01207: 480 mm x 400 mm x 84 mm or equivalent (LxWxT, 31 vertical fins, Aluminum heat sink, uncoated)

5.4 Conformance with EAC

EAC is the abbreviation for Eurasian Conformity. The mark is used in the states of the Eurasian Customs Union (Russia, Belarus, Kazakhstan) similar to the European CE mark.

Kollmorgen declares, that the device has passed all required conformity procedures in a member state of the Eurasian Customs Union, and that the device meets all technical requirements requested in the member states of the Eurasian Customs Union:

- Low voltage (TP TC 020/2011)
- Electromagnetic Compatibility (TP TC 004/2011)

Contact: SERVOSTAR LLC. , Bld.1, Semyonovskaya nab. 2/1, RU-105094 Moskau

5.5 Conformance with RoHS

The device is manufactured in conformance with RoHS Directive 2011/65/EU with delegated directive 2015/863/EU for installation into a machine.

5.6 Conformance with REACH

EU Regulation no. 1907/2006 deals with the registration, evaluation, authorization and restriction of chemical substances 1 (abbreviated to "REACH").

The device does not contain any substances (CMR substances, PBT substances, vPvB substances and similar hazardous substances stipulated in individual cases based on scientific criteria) above 0.1 mass percent per product that are included on the candidate list.

6 Package

6.1 Package Supplied	24
6.2 Nameplate	24
6.3 Part Number Scheme	25

6.1 Package Supplied

When a drive from the AKD-N series is ordered, the following items are included in the drive package:

- AKD-N with four mounting clamps
- Printed copy of *AKD-C/N Safety Notes*
- DVD containing the setup software, WorkBench, and all product documentation in digital format.
- Two connector covers M12 (for unused X3 and X6)

NOTE

The mating connectors are not included in the package.
The M23 connector cover for protecting X2 of the last AKD-N in a string is part of delivery of the AKD-C package.

Accessories Sold Separately

Accessories must be ordered separately if required; refer to your regional accessories manual:

- Heatsink 50 mm for AKD-N003/006
- Heatsink 50 mm for AKD-N012
- Heat conducting film
- Motor cable, feedback cable
- Hybrid cable for connection to next AKD-N
- Cable for digital I/O connection
- Cable for local STO connection (AKD-N-DS/DT only)
- Cable for tertiary fieldbus (AKD-N-DF/DG only)
- Connector AKD-N-JUMP-X5 for AKD-N-DS/DF with SFD3/DSL



Spare parts

Spare parts are described in the regional accessories manual:

- Mounting clamps set
- Sealing plug set for connectors

6.2 Nameplate

The nameplate depicted below is attached to the side of the drive, sample data entries are for a 12 A type. Picture similar to the nameplate on the device.

KOLLMORGEN		Customer Support: North America: +1 (540) 633-3400 Europe: +49 (0) 2102-9394-0 Italy: +39 (0) 362-594260		HW Rev: B																																			
Pempelfurtstr. 1 40880 Ratingen Germany		Model No: AKD-N01207-DFEC-E000		RoHS																																			
Serial No: D-1631-10030		MAC Address: 00:23:1B:30:06:CE		  																																			
<table border="1"> <thead> <tr> <th colspan="2">Input-Main</th> <th colspan="2">Output-DC-Bus</th> </tr> <tr> <th colspan="2"></th> <th>without cold plate: (*)</th> <th>with cold plate</th> </tr> </thead> <tbody> <tr> <td>Voltage</td> <td>560-680 Vdc</td> <td>Voltage</td> <td>0-480 Vac</td> </tr> <tr> <td>Frequency</td> <td>-</td> <td>Frequency</td> <td>0-<600 Hz</td> </tr> <tr> <td>Phase</td> <td>1 Ph</td> <td>Phase</td> <td>3 Ph</td> </tr> <tr> <td>FL Current</td> <td>15 A dc</td> <td>FL Current</td> <td>0.8 Arms</td> </tr> <tr> <td>Power</td> <td>7,7kVA</td> <td>Base Frequency</td> <td>8 kHz</td> </tr> <tr> <td></td> <td></td> <td></td> <td>(*)12 Arms</td> </tr> <tr> <td></td> <td></td> <td></td> <td>8 kHz</td> </tr> </tbody> </table>		Input-Main		Output-DC-Bus				without cold plate: (*)	with cold plate	Voltage	560-680 Vdc	Voltage	0-480 Vac	Frequency	-	Frequency	0-<600 Hz	Phase	1 Ph	Phase	3 Ph	FL Current	15 A dc	FL Current	0.8 Arms	Power	7,7kVA	Base Frequency	8 kHz				(*)12 Arms				8 kHz	Surrounding Air Temperature: max. 40 °C Enclosure Protection Rating: IP 67 UL Type rating: Type 1 SCCR: 42kA	
Input-Main		Output-DC-Bus																																					
		without cold plate: (*)	with cold plate																																				
Voltage	560-680 Vdc	Voltage	0-480 Vac																																				
Frequency	-	Frequency	0-<600 Hz																																				
Phase	1 Ph	Phase	3 Ph																																				
FL Current	15 A dc	FL Current	0.8 Arms																																				
Power	7,7kVA	Base Frequency	8 kHz																																				
			(*)12 Arms																																				
			8 kHz																																				
Before use, refer to DVD for installation and safety/(*)cold plate information. Assembled in Germany Patents Pending www.kollmorgen.com																																							

6.3 Part Number Scheme

Use the part number scheme for product identification only, not for the order process, because not all combinations of features are possible, always.

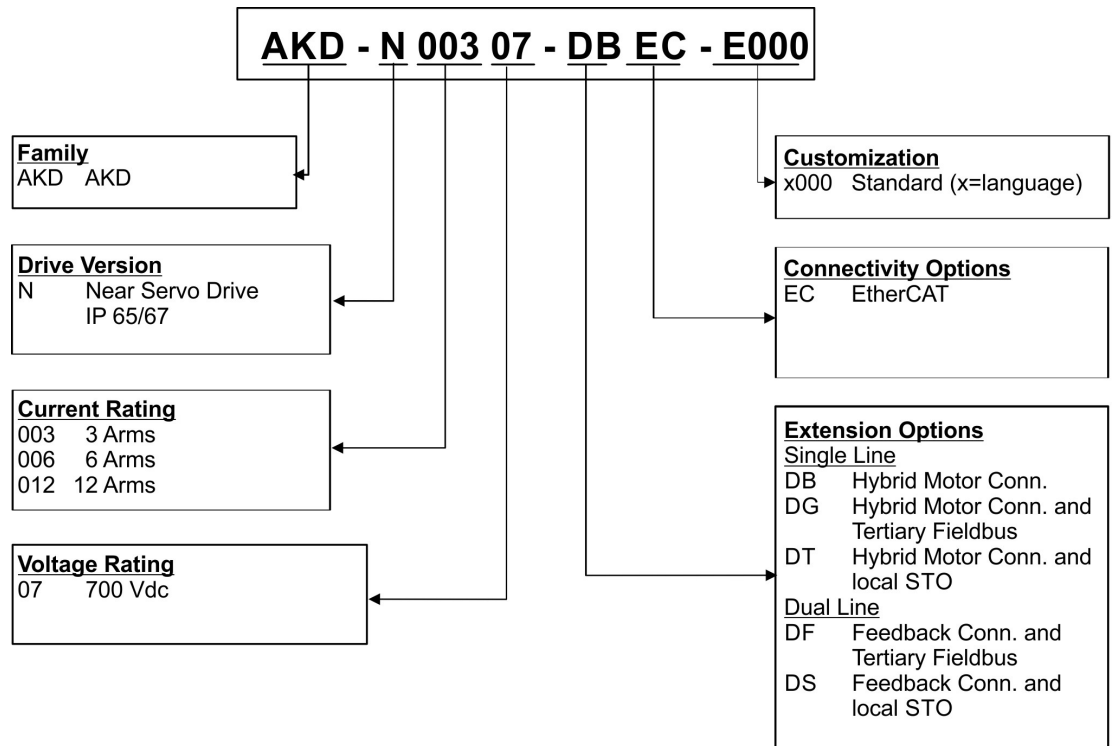

Customization code includes language version of printed material and not safety relevant customer specials.

7 Technical description and data

7.1 The AKD-N Family of Digital Drives	27
7.2 Mechanical Data	28
7.3 Electrical Data	28
7.4 Performance Data	28
7.5 Ambient Conditions, Ventilation, and Mounting Position	29
7.6 Inputs/Outputs	29
7.7 Connectors	30
7.8 Cable Requirements	31
7.9 Cable length definition	32
7.10 Regen circuit	33
7.11 LED Codes	34
7.12 Switch-On and Switch-Off Behavior	35
7.13 Safe Torque Off (STO)	42

7.1 The AKD-N Family of Digital Drives

Available AKD-N versions

Variant (short)	Description	Current	Connectivity
AKD-N-DB	Hybrid DC power and fieldbus connection. Hybrid motor connection.	3 to 12 A	EtherCAT, I/O
AKD-N-DG	Hybrid DC power and fieldbus connection. Hybrid motor connection. Local tertiary fieldbus interface.	3 to 12 A	EtherCAT, I/O, Local Fieldbus
AKD-N-DT	Hybrid DC power and fieldbus connection. Hybrid motor connection. Local drive STO input.	3 to 12 A	EtherCAT, I/O, Local STO
AKD-N-DF	Hybrid DC power and fieldbus connection. Dual cable motor power and feedback connection. Local tertiary fieldbus interface.	3 to 12 A	EtherCAT, I/O, Local Fieldbus
AKD-N-DS	Hybrid DC power and fieldbus connection. Dual cable motor power and feedback connection. Local drive STO input.	3 to 12 A	EtherCAT, I/O, Local STO

Standard features

- Supply voltage range 55 VDC to 800 VDC
- Motion bus onboard.
- SFD, HIPERFACE DSL, Comcoder, EnDat 2.1 & 2.2, BiSS, HIPERFACE, 1Vp-p Sin-Cos encoders, incremental encoders support onboard.
- Safe Torque Off (STO) according to IEC 62061 SIL 2 onboard.
- Use with synchronous servomotors, linear motors, and induction machines.

Power section

- Connection to AKD-C or MKD-C power supplies.
- DC power supply, voltage range 55 VDC to 800 VDC.
- Output stage IGBT module with floating current measurement.

Integrated safety

- Appropriate insulation/creepage distances and electrical isolation for safe electrical separation, per IEC 61800-5-1, between the power input/motor connections and the signal electronics.
- Temperature monitoring of the drive and motor.
- Motor overload protection: foldback mechanism
- SIL 2 safe torque off in accordance with IEC 62061

Operation and parameter setting

- Using the setup software WorkBench for system setup via TCP/IP connected to X18 of the power supply.

Full digital control

- Digital current controller (670 ns)
- Adjustable digital velocity controller (62.5 μ s)
- Software option position controller (250 μ s)

Inputs/Outputs

- 3 programmable digital inputs (\rightarrow # 65)
- 1 programmable digital outputs (\rightarrow # 65)

7.2 Mechanical Data

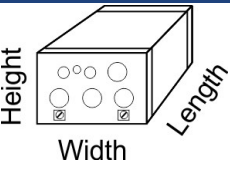
	Mechanical data	Units	AKD-N00307	AKD-N00607	AKD-N01207
	Weight	kg	1.6		approx. 2.1
	Height	mm	75		75
	Width	mm	130		130
	Length, housing	mm	201		252
	Length, with connectors and mounting clamps	mm	247		297

7.3 Electrical Data

Electrical data	Units	AKD-N00307	AKD-N00607	AKD-N01207
Rated supply voltage	V=	560 to 680		
Standby supply voltage	V=	55		
Rated input power for continuous operation	kVA	1.5	3	7.7
Rated input current	A	2.8	5.5	15
Permitted switch on/off frequency	1/h	30		
Continuous output current (± 3%):				
Optimum cooling situation (cold plate size definition fulfilled)	Arms	3 ¹⁾	6 ²⁾	12 ³⁾
Free convection cooling, unmounted	Arms	1.8	1.7	0.8
Continuous output power:				
Optimum cooling situation (cold plate size definition fulfilled)	kW	1.3	2.6	5
Free convection cooling, unmounted	kW	0.8	0.7	0.3
Peak output current (for 5 s, ± 3%)	Arms	9	18	30
Peak output power (for 5 s)	kW	3.9	7.8	15.6
Motor inductance min.	mH	6.3	3.2	2.5
Motor inductance max.	mH	600	300	250
Thermal dissipation, output stage disable	W	max. 6	max. 6	max. 6
Thermal dissipation at rated current	W	37	71	150
Efficiency factor	%	97	97	97
Technical data for regen circuit	—	→ p. 1		
Motor holding brake current	A	max. 1	max. 1.5	max. 1.5

1) cold plate: (LxWxT) 240x240x10, aluminum, surrounding temp. 40°C, supply voltage: 680V

2) cold plate: (LxWxT) 500x500x10, aluminum, surrounding temp. 40°C, supply voltage: 680V

3) heat sink: (LxWxT) 480x400x84, 31 vertical fins, aluminum, surrounding temp. 40°C, supply voltage: 680V

7.4 Performance Data

Performance Data	Units	AKD-N00307	AKD-N00607/01207
Switching frequency of output stage	kHz	10	8
Voltage rise speed dU/dt	kV/μs	7.2	
Bandwidth of current controller	kHz	2.5	

Performance Data	Units	AKD N00307	AKD-N00607/01207
Bandwidth of velocity controller (scalable)	Hz		0 to 750
Bandwidth of position controller (scalable)	Hz		1 to 250

7.5 Ambient Conditions, Ventilation, and Mounting Position

Storage	(→ # 16)
Transport	(→ # 16)
Surrounding air temperature in operation	-10 °C to +40 °C under rated conditions +40 °C to +55 °C with continuous current derating 4 % per Kelvin
Humidity in operation	Relative humidity 5 to 95%, no condensation, class 3K4
Site altitude	Up to 1000 meters above mean sea level without restriction 1,000 to max. 2,000 meters above mean sea level with current derating 1.5%/100 m
Pollution level	Pollution level 3 as per IEC 60664-1
Vibrations	Class 3M5 according to IEC 60721-3-3
Environmental area	IP65/IP67 according to IEC 60529, UL Type 4x
Mounting position	All orientations allowed, observe preferred position, (→ # 52)
Cold plate size	Aluminum cold plate minimum size: AKD-N00307: cold plate 350x350x10 mm AKD-N00607: cold plate 500x500x10 mm AKD-N01207: heat sink 480x400x84 mm, 31 fins The drive operates to full ratings, if the mounting surface for the cold plate is between -10°C and +85°C and the surrounding air temperature is between -10°C and +40°C.
Ventilation	Free air convection

7.6 Inputs/Outputs

Interface	Electrical Data
Digital inputs (X3)	<ul style="list-style-type: none"> ● as per IEC61131-2 type 1 ● ON: 15 VDC to 30 VDC, 2 mA to 15 mA ● OFF: -3 VDC to 5 VDC, < 1 mA ● galvanic isolation for 30 VDC ● 2 high speed inputs: update rate 2 µs ● 1 standard input: update rate 250 µs
Digital outputs (X3)	<ul style="list-style-type: none"> ● as per IEC61131-2 type 1 ● max. 30 VDC, 100 mA ● short circuit proof ● galvanic isolation for 30 VDC ● Update rate 250 µs
STO input (X6 option DS/DT)	<ul style="list-style-type: none"> ● ON: 18 VDC to 30 VDC, 80 mA ● OFF: 0 VDC to 12 VDC, < 50 mA ● galvanic isolation for 60 VDC

Interface	Electrical Data
STO outputs (X3, option DS/DT)	<ul style="list-style-type: none"> ● as per IEC61131-2 type 1 ● max. 30 VDC, 100 mA ● short circuit proof ● galvanic isolation for 30 VDC ● Update rate 62.5 μs

7.7 Connectors

Given voltage and current data are the lowest values allowed by UL and CE.

Connector	Type	Max. Cross Section	Current	Voltage*
Hybrid IN, X1	Hybrid Connector (male), 7 poles	4 x 0.34mm ² , 22 awg 3 x 2.5 mm ² , 14 awg	0.5 A 18 A	30 V 850 V
Hybrid OUT, X2	Hybrid Connector (female), 7 poles	4 x 0.34mm ² , 22 awg 3 x 2.5 mm ² , 14 awg	0.5 A 18 A	30 V 850 V
Digital I/O, X3	Connector (female), 8 poles	8 x 0.34 mm ² , 22 awg	2 A	30 V
Motor/Hybrid, X4	Connector (female), 8 poles	4 x 2.5 mm ² , 14 awg 4 x 1.0 mm ² , 18 awg	15 A 10 A	630 V 30 V
Feedback X5	Connector (male), 17 poles	17 x 0.75 mm ² , 20 awg	3.6 A	63 V
STO/Fieldbus, X6	Connector (female), 4 poles	4 x 0.34 mm ² , 22 awg	1 A	50 V

* Rated voltage with pollution level 2, use Kollmorgen cables only.

7.8 Cable Requirements

For information on the chemical, mechanical, and electrical characteristics of the cables please refer to the accessories manual or contact customer support.

NOTE

Use Kollmorgen hybrid, motor, and feedback cables only. You will lose system warranty, if you use hybrid, motor or feedback cables from a manufacturer other than Kollmorgen.

Cable from	Cable to	Cable type	Cross section
AKD-C X20/X21	AKD-N X1, hybrid	CCNCN1-025 ^①	3 x 2.5 mm ² 4 x 0.25 mm ²
MKD-C X20/X21	AKD-N X1, hybrid	MKC-HYB-* AKN ^①	3 x 2.5 mm ² + 4 x 0.25 mm ²
AKD-N X2	AKD-N X1, hybrid	CCNNN1-025 ^①	3 x 2.5 mm ² 4 x 0.25 mm ²
AKD-N X3	Digital I/O	Phoenix SAC- 8P-M12MS ^②	8 x 0.25 mm ²
AKD-N-DF/DG X6	D-coded, Tertiary Fieldbus	Phoenix SAC- 4P-M12MSD ^②	2 x 2 x 0.14 mm ²
AKD-N-DS/DT X6	A-coded, Single Drive STO switch	Phoenix SAC- 4P-M12MS ^②	4 x 0.34 mm ²
AKD-N	AKM Motor		
AKD-N-DB/DG/DT X4	Motor Power with brake and Hiperface DSL feedback, hybrid	CCJNAz-015 ^①	4 x 1.5 mm ² 2 x 0.75 mm ² 2 x 0.34 mm ²
AKD-N-DF/DS X4	Motor Power without brake	CM0NAz-015 ^①	4 x 1.5 mm ²
AKD-N-DF/DS X4	Motor Power with brake	CM1NAz-015 ^①	4 x 1.5 mm ² 2 x 0.75 mm ²
AKD-N-DF/DS X5	Motor Feedback SFD	CFSNAz-002 ^①	4 x 2 x 0.25 mm ²
AKD-N-DF/DS X5	Motor Feedback Comcoder	CFCNAz-002 ^①	7 x 2 x 0.25 mm ²
AKD-N-DF/DS X5	Motor Feedback EnDat/BiSS	CFENAz-002 ^①	7 x 2 x 0.25 mm ²
AKD-N-DF/DS X5	Motor Feedback Hiperface	CFHNA1-002 ^①	7 x 2 x 0.25 mm ²
AKD-N	AKM2G Motor	refer to Kollmorgen website: <i>Kollmorgen 2G Cable Guide</i>	

z: 1 = Connector M23, 2 = Connector SpeedTec (CC only)

* = S (static), I (intermediate to 100 m/min, 1G), D (dynamic up to 300 m/min, 2.5G)

① Followed by length coding. Contact your Kollmorgen sales representative.

② Example, similar cables are available from other distributors.

7.9 Cable length definition

NOTE

AKD-C offers two separate strings to connect up to 8 AKD-N to each of them. Maximum total cable length for each string is 100 m. For system topology information refer to (→ # 57)

Cable Type	Cable usage	Available Length (m)	Max. Length (m)
CCNCN1	AKD-C to AKD-N, hybrid	3, 6, 12, 24, 36	40
MKC-HYB-*AKN	MKD-C to AKD-N X1, hybrid	3, 6, 12, 24, 36	40
CCNNN1	AKD-N to AKD-N, hybrid	0.25, 0.5, ... , 2.0 (steps 0.25m) 2.5, 3.0, ... , 25 (steps 0.5m)	25
CCJNAz	AKD-N-DG/DT to Motor, hybrid	0.2, 0.3, ... , 1.0 (steps 0.1m) 1.25, 1.5, ... , 2.0 (steps 0.25m)	5
CMxNAz	AKD-N-DF/DS to Motor, Power	2.5, 3.0, ... , 5.0 (steps 0.5m)	
CFyNAz	AKD-N-DF/DS to Motor, Feedback		
single line	X13 +24 V/GND, X15 Digital I/Os, X16 STO Signals		30

z: 1 = Connector M23, 2 = Connector SpeedTec (CC only)

*= S (static), I (intermediate to 100 m/min, 1G), D (dynamic up to 300 m/min, 2.5G)

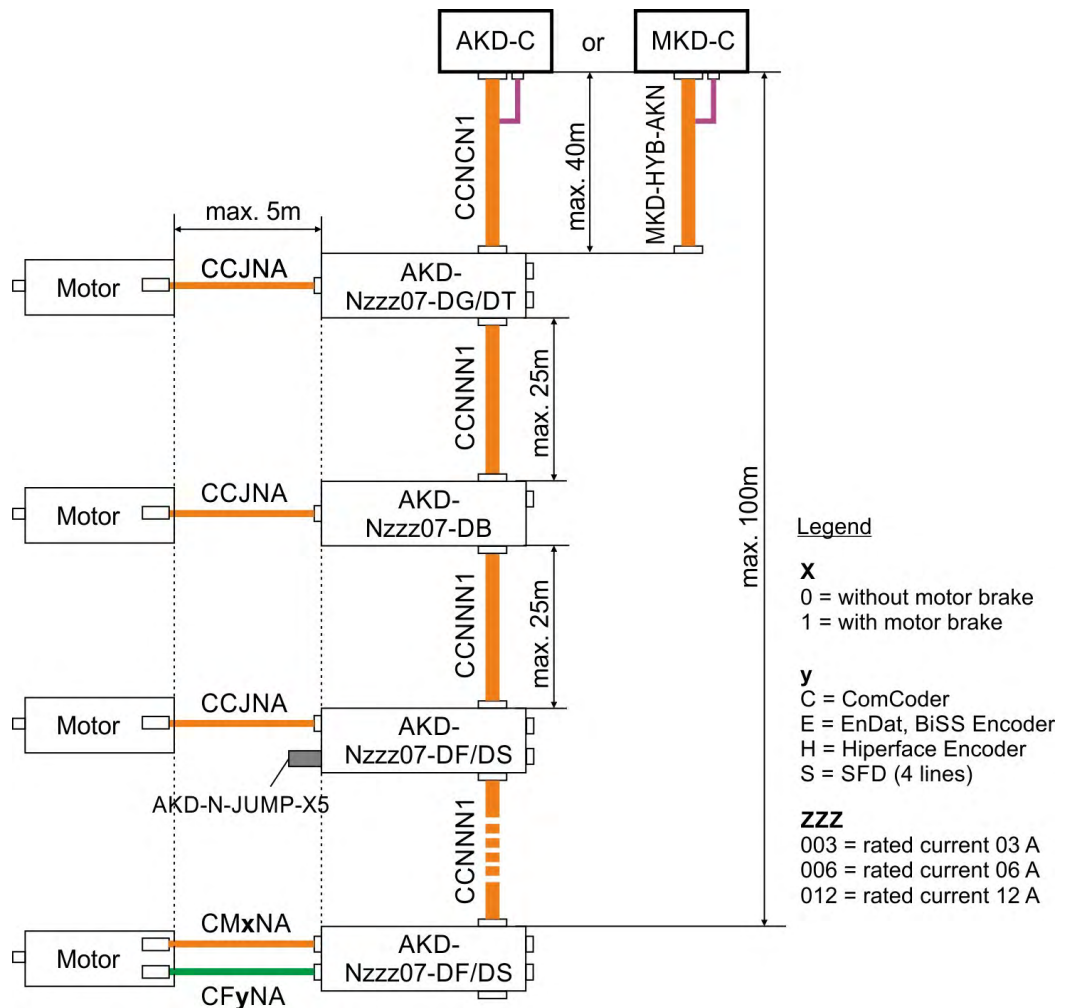

7.10 Regen circuit

The AKD-C has an internal regen resistor, MKD-C does not offer an internal resistor. An external regen resistor can be connected to X14 on both power supplies.

External regen resistors are described in the regional *AKD Accessories Manual*.

7.10.1 Functional description

When the amount of returned energy builds the bus capacitor voltage up enough the power supply activates the brake chopper to start dumping the returned energy in the regen resistor. 90% of the combined power of all the coupled drives is always available for peak and continuous power.

Switch-off on over voltage

The drive that has the lowest switch-off threshold (resulting from tolerances) reports an over-voltage fault if the DC bus threshold is exceeded. The drive power stage is disabled and the load coasts to a stop with the fault message "F501 Bus Over voltage". The fault relay contact (AKD-C: X15/5-6, MKD-C: X15A/1-2) is opened due to this fault.

7.10.2 Technical data

Technical data are listed in the installation manuals for *AKD-C / MKD-C*.

7.11 LED Codes

The built-in LED indicates the status of the drive after the 24 V supply for AKD-C is switched on. If the AKD-C service connection to the PC or to the PAC doesn't work, then the LED is the only way to get information.

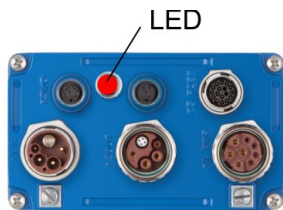

⚠ DANGER High voltage up to 900 V!

There is a danger of serious personal injury or death by electrical shock or electrical arcing. The built-in LED does **not** indicate the real voltage level.

- Always measure the voltage in the DC bus link at connector X14 at AKD-C respectively X23 at MKD-C and
- wait until the voltage is below 50 V before handling any component in the decentral servo system.

The LED delivers information with three colors (red, green, yellow) and blink frequency. Specialist can analyze the blink frequency, more information to that can be found in the WorkBench online help.

Basic information

Color	Remarks
Green	Enabled and running
blink green/orange	Enabled and running with warning
blink orange	Safe bus voltage
blink red/orange/green	Fault

7.12 Switch-On and Switch-Off Behavior

Behavior of “holding brake” function

Drives with an enabled holding brake function have a special timing for switching on and off the output stage. Events that remove the DRV.ACTIVE signal trigger the holding brake to apply. As with all electronic circuits, the general rule applies that there is a possibility of the internal holding brake module failing.

Functional safety, for example with hanging load (vertical axes), requires an additional mechanical brake which must be safely operated, for example by a safety control.

If velocity drops below threshold $CS.VTHRESH$ or timeout occurs during a stop procedure, the brake is applied. Set parameter MOTOR.BRAKEIMM to 1 with vertical axes, to apply the motor holding brake immediately after faults or Hardware Disable.

Safety function STO

With the functional safe function STO, the drive can be secured on standstill using its internal electronics so that even when power is being supplied, the drive shaft is protected against unintentional restart. The chapter “Safe Torque Off (STO)” describes how to use the STO function (→ # 42).

7.12.1 Switch-on behavior in standard operation

The diagram below illustrates the correct functional sequence for switching the drive on.

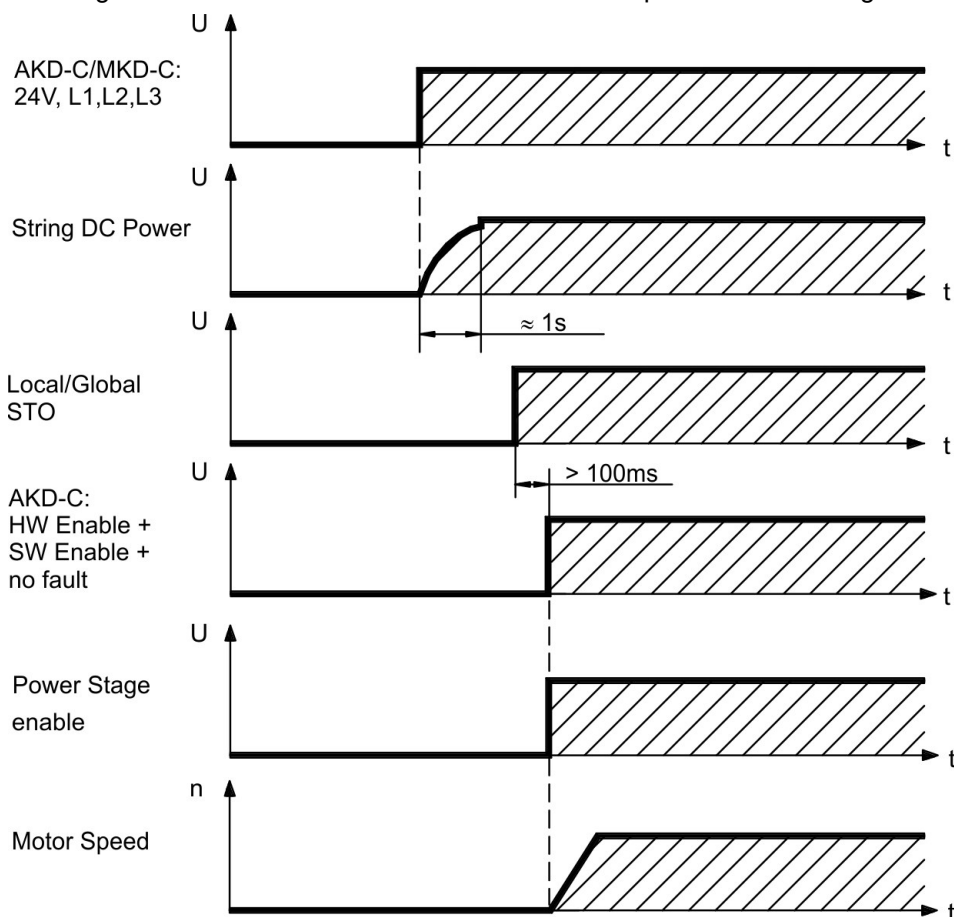

7.12.2 Switch-off behavior

NOTE The AKD-C/MKD-C 24 V supply must remain constant. Hardware Enable input disables all AKD-N power stages immediately. Configured Digital Inputs and fieldbus commands can be used to perform controlled stops.

The control functions Stop, Emergency Stop and Emergency Off are defined by IEC 60204. Notes for safety aspects of these functions can be found in ISO 13849 and IEC 62061.

NOTE The parameter DRV.DISMODE must be set to 2 to implement the different stop categories. Consult the *WorkBench Online Help* for configuring the parameter.



WARNING No Functional Safety!

Serious injury could result when a suspended load is not properly blocked. Functional safety, e.g. with hanging load (vertical axes), requires an additional mechanical brake which must be safely operated, for example by a safety control.

- Add a safe mechanical blocking (for instance, a motor-holding brake).
- Set parameter MOTOR.BRAKEIMM to 1 with vertical axes, to apply the motor holding brake immediately after faults or Hardware Disable.

7.12.2.1 Switch-off behavior using a digital input (controlled stop)

This is a category 2 stop according to IEC 60204. A digital input can be configured to bring the motor to a controlled stop and then disable the drive and apply the holding brake (if present). See the *WorkBench Online Help* for information on configuring Digital Inputs.

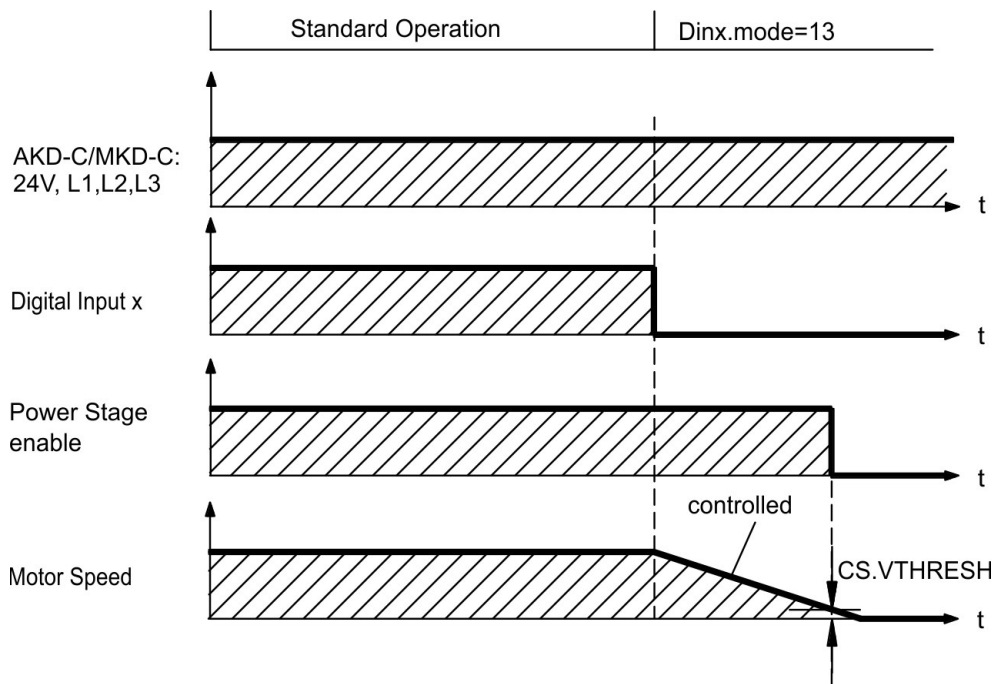

If velocity drops below threshold *CS.VTHRESH* or timeout occurs brake is applied.

7.12.2.2 Switch-off behavior using the DRV.DIS command

The enable/disable button in WorkBench issues a *drv.dis* command internally to the drive. See *WorkBench Online Help* for configuring inputs and software commands. Sometimes this enable signal is called "Software Enable" (SW-Enable).

DRV.DISMODE 0	Disable axis immediately, if velocity drops below threshold <i>CS.VTHRESH</i> or timeout occurs brake is applied. Category 0 stop according to IEC 60204 (→ # 42).
DRV.DISMODE 2	Use controlled stop to disable drive, if velocity drops below threshold <i>CS.VTHRESH</i> or timeout occurs brake is applied. Category 1 stop according to IEC 60204 (→ # 42).

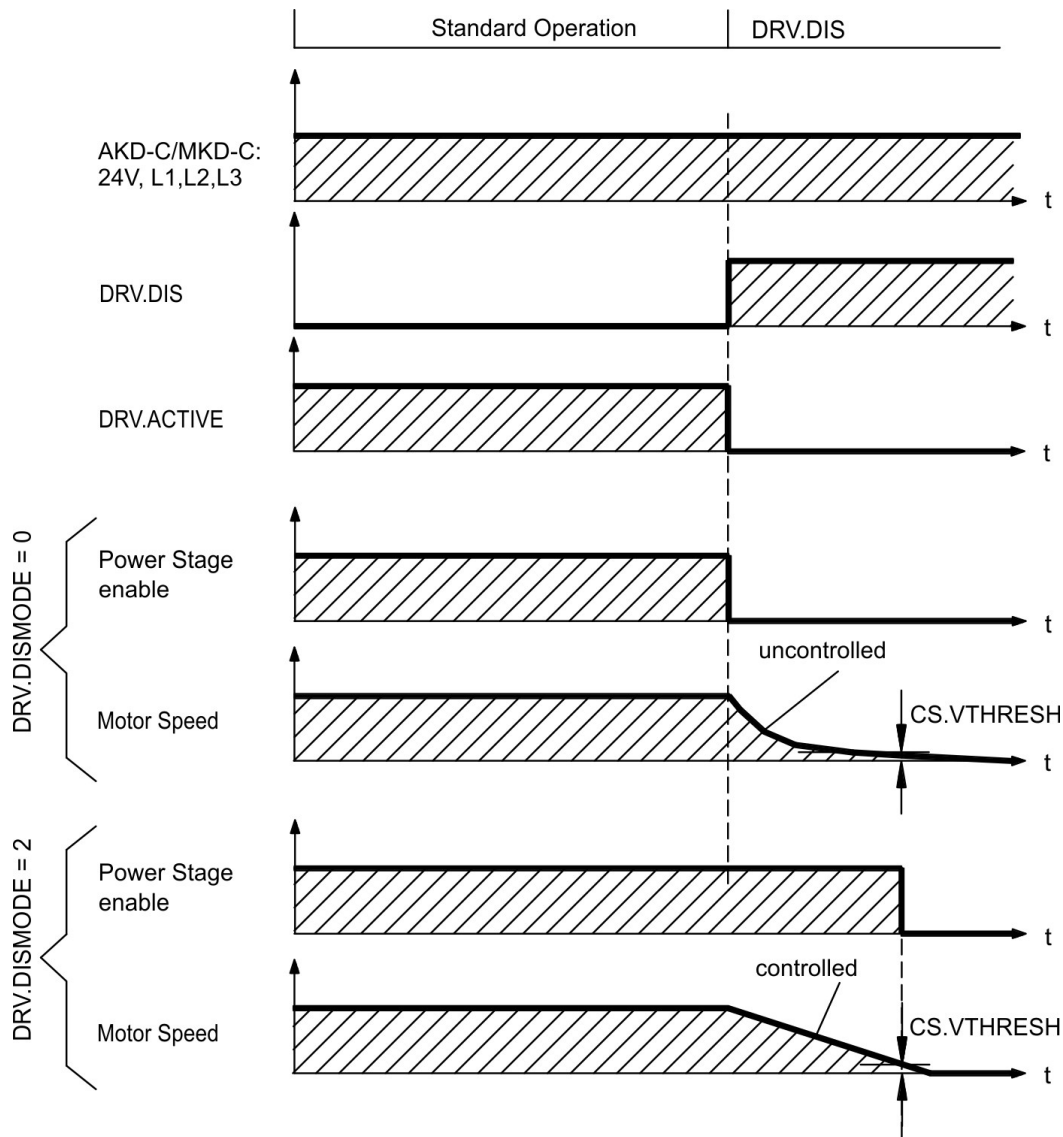

If velocity drops below threshold *CS.VTHRESH* or timeout occurs brake is applied.

7.12.2.3 Switch-off behavior using HW Enable input on AKD-C (uncontrolled stop)

This is a category 0 stop according to IEC 60204. The hardware enable input disables the AKD-N power stage immediately.

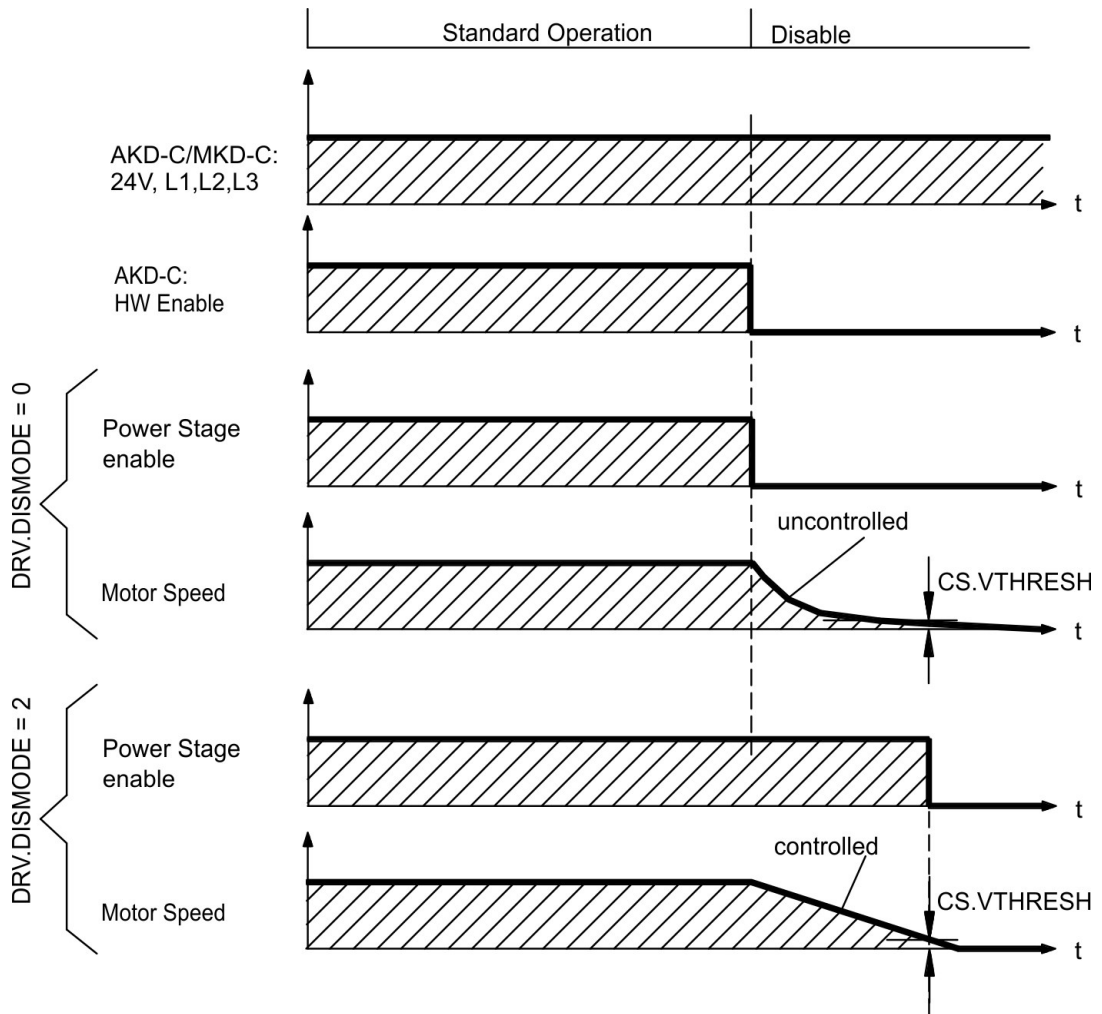

If velocity drops below threshold $CS.VTHRESH$ or timeout occurs the motor holding brake is applied. Set parameter `MOTOR.BRAKEIMM` to 1 with vertical axes, to apply the motor holding brake immediately after Hardware Disable.

7.12.2.4 Switch-off behavior in the event of a fault

The behavior of the drive always depends on the fault type and the setting of a number of different parameters (DRV.DISMODE, VBUS.UVFTHRESH, CS.VTHRESH, and others; see the *WorkBench Online Help* for more details). See the *Drive Fault and Warning Messages and Remedies* section of the *WorkBench Online Help* for a table describing the specific behavior of each fault. The following pages show examples for the possible fault behaviors.

Switch-off behavior for faults that cause an immediate power stage disable

This is a category 0 stop according to IEC 60204.

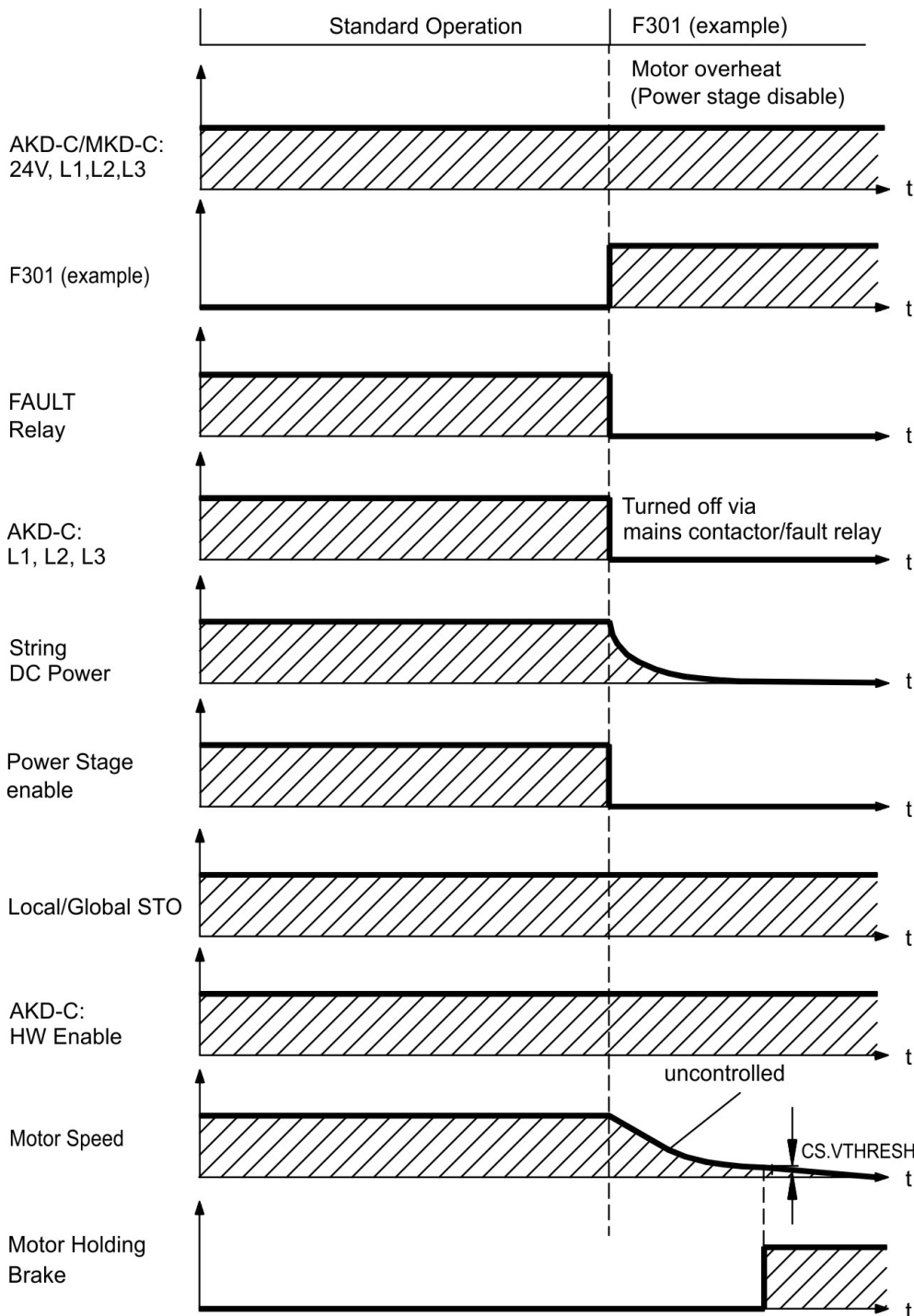

If velocity drops below threshold $CS.VTHRESH$ or timeout occurs the motor holding brake is applied. Set parameter $MOTOR.BRAKEIMM$ to 1 with vertical axes, to apply the motor holding brake immediately after faults.

Switch-off behavior for faults that cause dynamic braking

This is a category 0 stop according to IEC 60204.

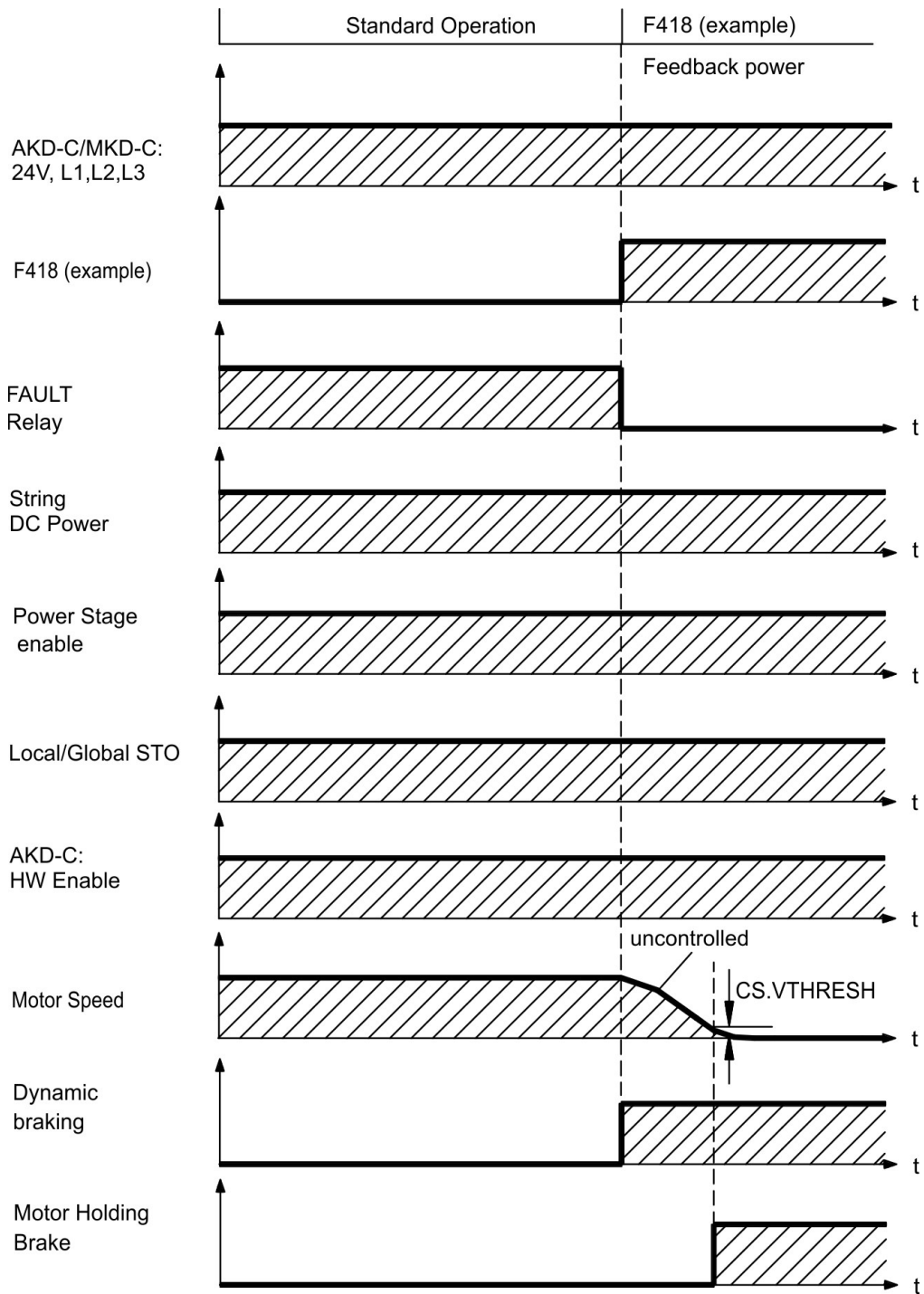

If velocity drops below threshold $CS.VTHRESH$ or timeout occurs brake is applied .

Switch-off behavior for faults that cause a controlled stop

This is a category 1 stop according to IEC 60204.

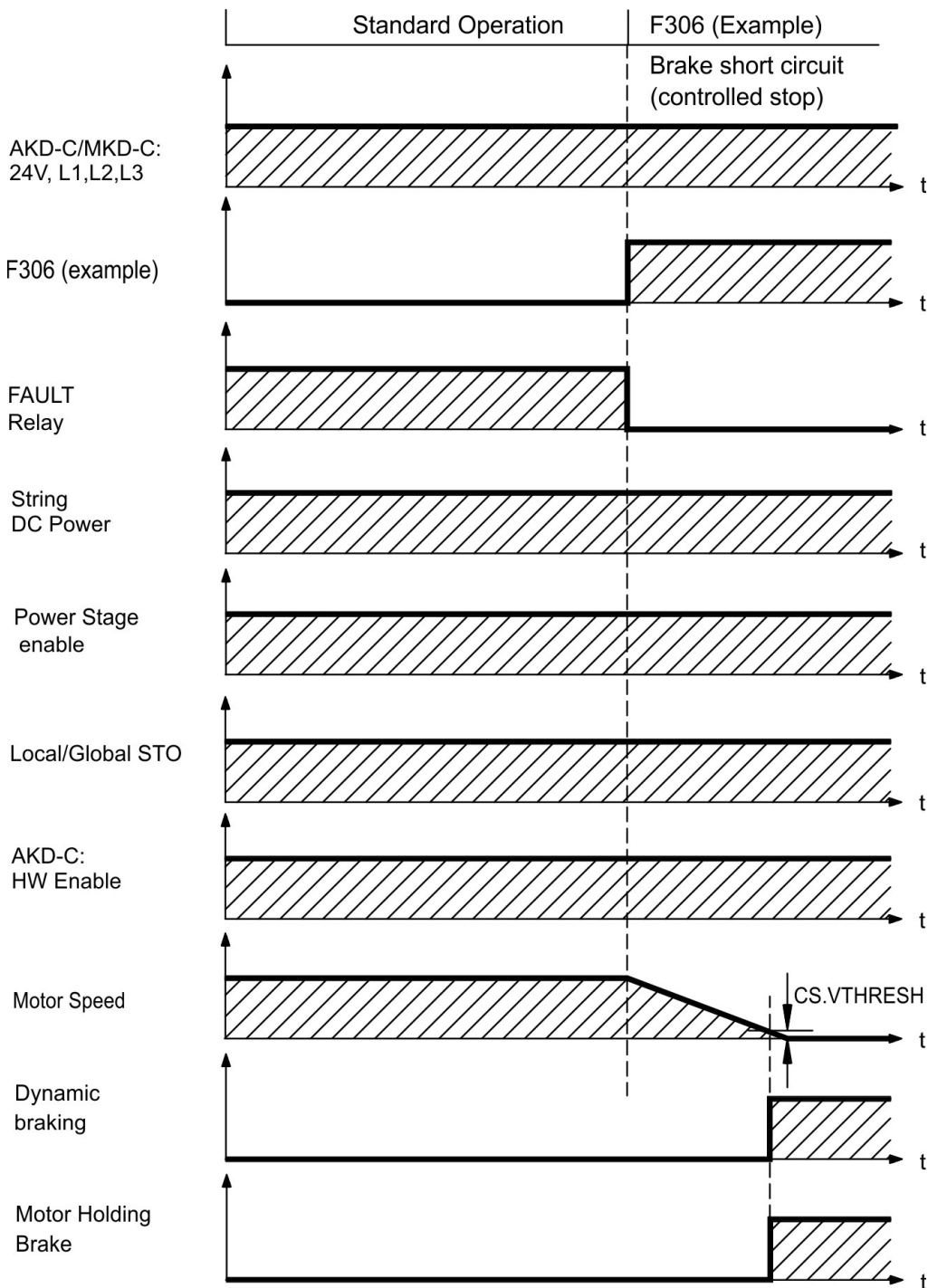

If velocity drops below threshold $CS.VTHRESH$ or timeout occurs brake is applied .

7.13 Safe Torque Off (STO)

The STO functionality of AKD-N with option "DB" or "DF" or "DG" is controlled by the AKD-C or MKD-C smart power supply via the specific string, where the AKD-N is connected to. This STO topology is called "*Global STO*" or "*String STO*".

AKD-N drives with option "DS" or "DT" offer an additional connector X6 with a digital STO-Enable input. This STO functionality is called "Local STO". These drive variants cannot be safety controlled by the global STO functionality.

7.13.1 Global STO, control via AKD-C

Connector X16 on the AKD-C offers access to all STO signals of the decentral drive system powered by this AKD-C. There is one STO-Enable input and one STO-Status output for each DC Power string.

The global STO function is described in the *AKD-C Installation Manual*.

Application examples can be found in the *Decentralized System Project Guide*.

NOTE

The global STO function uses the following devices: AKD-C, AKD-N without option "DS/DT", Kollmorgen hybrid connection cable.

In case of using an AKD-N with option "DS" or "DT" (local STO input), the global STO-Enable signal will have not influence to this specific drive. The local STO-Status of this drive nevertheless is monitored in the string STO-Status.

7.13.2 Global STO, control via MKD-C

Connector X16A/B on the MKD-C offers access to all STO signals of the decentral drive system powered by this MKD-C. There is one STO input and one STO-Status output for every DC Power string.

The global STO function is described in the *MKD-C Installation Manual*.

NOTE

The global STO function uses the following devices: MKD-C, AKD-N without option "DS" or "DT", Kollmorgen hybrid connection string cable.

In case of using AKD-N with option "DS" or "DT" (local STO input), the global STO signal will have no influence to these specific drives.

In case of using more than 8 AKD-N with Hardware Revision A or B in one string, you must connect a signal buffer to the STO signal.

Maximum device number per string:

- Hardware Revision A or B: maximum 8 AKD-N
- Hardware Revision A or B with signal buffer: maximum 14 AKD-N
- Hardware Revision C: maximum 14 AKD-N

7.13.3 Local STO, control via digital input on AKD-N-DS/DT

Option "DS" and "DT" on the AKD-N offer local STO-Enable functionality. There is one STO-Enable input on X6 and one STO-Status output on X3 for the drive. The STO-Status outputs on X3 are available only with AKD-N drives with option "DS" or "DT".

7.13.4 Safety characteristic data

The systems are described with the following characteristics:

Structure	STO	ISO 13849-1	MTTF _d	IEC 62061	PFH [1/h]	SFF [%]	T _M [Years]
AKD-C + 1 x AKD-N	global	PL d, CAT 3	≥ 100	SIL 2	2.99E-08	97.08	20
AKD-C + 8 x AKD-N	global	PL d, CAT 3	≥ 100	SIL 2	3.07E-08	99.44	20
MKD-C+ 14 x AKD-N	global	PL d, CAT 3	≥ 100	SIL 2	1.86E-08	94.20	20
1 x AKD-N-DS/DT	local	PL d, CAT 3	≥ 100	SIL 2	2.9E-08	97.12	20

NOTICE

A very unlikely but possible event can happen, if within a very short time 2 not adjacent IGBTs will have a short circuit. In such case a movement of a maximum angle of 120° (electrical) can happen. This effect can only happen if the drive is in the function STO. If the total failure rate of the IGBT is 120 FIT normally for such short circuit 60 FIT will be valid (50:50 model). By such event 2 specific IGBTs have to fail at same time. The calculation shows a probability of $1.5 \cdot 10^{-15}$ per hour (without common cause failure). Even if the STO function will be issued for a whole year, this event will only happen every 100 Billion years.

7.13.5 Use as directed

The STO function is exclusively intended to provide a functional safe torque off of the drive. To achieve this functional safety, the wiring of the safety circuits must meet the safety requirements of IEC 60204, ISO 12100 and ISO 13849.

If the local STO function is in use, then the input STO must be connected to the exit of a safety control or a safety relay, which at least meets the requirements of PLd, CAT 3 according to ISO 13849.

The 24 VDC supply unit for local STO supply must accord to PELV (EN 60204-1) requirements.

7.13.6 Prohibited use

The STO function must not be used if the drive is to be made inactive for the following reasons:

- Cleaning, maintenance and repair operations, long inoperative periods. In such cases, the entire system should be disconnected from the supply and secured (main switch).
- Emergency-Off situations. In an Emergency-Off situation, the main relay is switched off (by the Emergency-Off button).
- Wiring the system with hybrid cables from other manufacturers than Kollmorgen is not allowed.
- Changing cables or connectors is not allowed.
- Do not use STO Status signals for functional safety.

7.13.7 Response Time

Global STO

The delay from falling edge at global STO Enable input until energy supply to the motors is interrupted, depends on the number of connected AKD-N to the string. Maximum reaction time is 10 ms. The more AKD-N are connected to the string, the shorter is the reaction time.

Local STO

The delay from falling edge at local STO Enable input until energy supply to the motor is interrupted is maximum 10 ms.

7.13.8 Enclosure, wiring

NOTE

Avoid pollution of the connectors with conductive obstacles. Observe the required ambient conditions as described in chapter (→ # 29). The AKD-N can be used in an environment that requires IP67 devices.

The cables must be laid durably (firmly), protected from outside damage (for example, by laying the cable in a duct), placed in different sheathed cables, or protected individually by grounding connection.

Wiring must meet the requirements of the standard IEC 60204-1.

Maximum cable length for safety relevant I/Os and for the 24 V supply is 30 m.

7.13.9 Local STO safety instructions



⚠ WARNING No Brake Power!

Serious injury could result when a suspended load is not properly blocked. The drive cannot hold a vertical load when STO is active.

The drives have not to be used for driving elevators.

- Add a safe mechanical blocking (for instance, a motor-holding brake).



⚠ CAUTION Automatic Restart!

Risk of death or serious injury for humans working in the machine. The drive might restart automatically after power on, voltage dip or interruption of the supply voltage, depending on the parameter setting. If parameter DRV.ENDEFAULT is set to 1,

- then place a warning sign ("WARNING: Possible Automatic Restart" or similar) to the machine.
- Ensure, that power on is not possible, while humans are in a dangerous zone of the machine.
- In case of using an undervoltage protection device, you must observe EN 60204-1:2006 chapter 7.5 .



⚠ CAUTION High electrical voltage!

Risk of electrical shock! The STO function does not provide an electrical separation from the power output. If access to the motor power terminals is necessary,

- disconnect the drive from AKD-C/MKD-C,
- consider the discharging time of the DC-Bus link.

NOTICE

If the safety function STO is automatically activated by a control system, then make sure that the output of the control is monitored for possible malfunction. The monitoring can be used to prevent a faulty output from unintentionally activating the STO function. Since the local STO function is a single-channel system, erroneous engaging will not be recognized.

NOTICE

It is not possible to perform a controlled brake if the drive controlled STO-Enable is off. If controlled braking before the use of the STO function is necessary, the drive must be braked and the input STO must be separated time-delayed from +24 V .

NOTICE

In case of a specific double fault within a very short time (→ # 43) a single movement of a maximum angle of 120° (electrical) can happen. This effect can only happen if the drive is in the function STO. Even if the STO function will be issued for a whole year, this event will only happen every 100 Billion years.

NOTE

The STO Status signals are informal and not relevant for functional safety.

7.13.10 Technical data and pinout local STO

NOTE The local STO input is not compatible with IEC 61131-2.

STO-Enable input	<ul style="list-style-type: none"> ● Input does not match IEC61131-2 ● ON: 18 VDC to 30 VDC, 80 mA ● OFF: 0 VDC to 12 VDC, < 50 mA ● Galvanic isolation for 250 VDC ● Tolerated OSSD pulse duration 0.3 ms
STO-Status outputs	<ul style="list-style-type: none"> ● As per IEC61131-2 type 1 ● Max. 30 VDC, 100 mA ● Galvanic isolation for 250 VDC
24 VDC Power supply	<ul style="list-style-type: none"> ● PELV acc. to EN 60204-1 ● Output 24 VDC +/-10%

Wiring diagram local STO-Enable

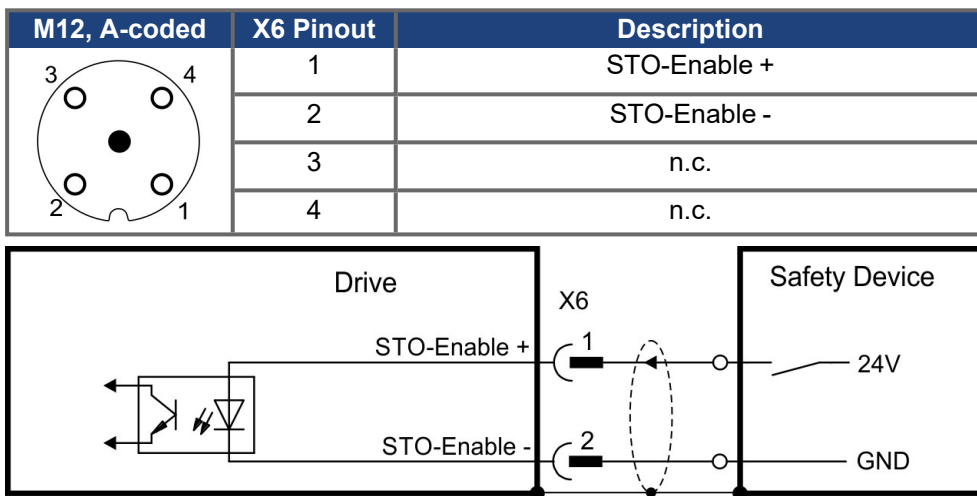

Wiring diagram local STO-Status

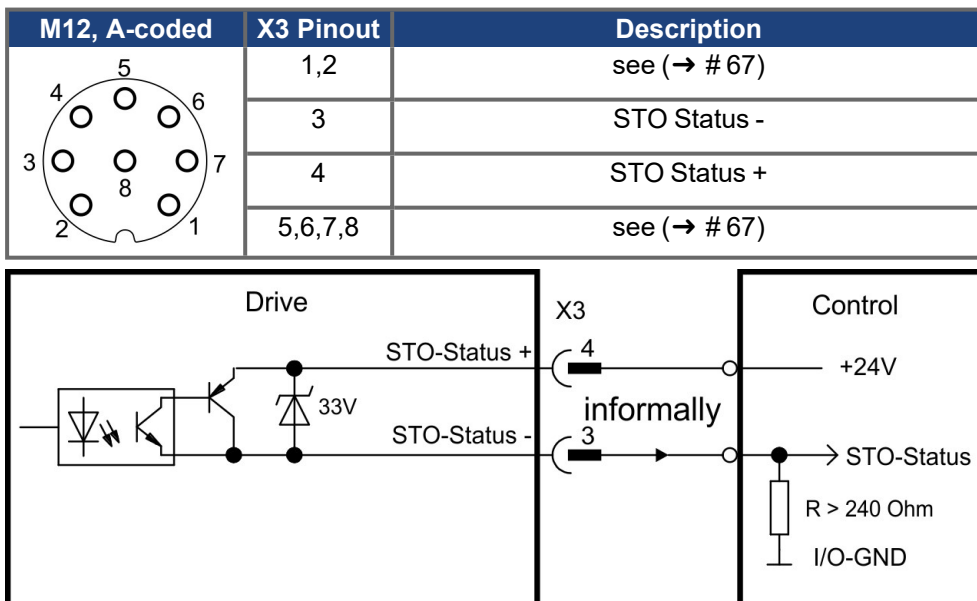

7.13.11 Functional description local STO

With AKD-N with option DS or DT, an additional digital input (STO) releases the power output stage of the drive as long as a 24 V signal is applied to this input. When the local STO function (Safe Torque Off) is not needed, then the input STO must be connected directly to +24 VDC. The function is then bypassed and cannot be used.

NOTE

The global STO signal will have no influence to this drive. The local STO input on the AKD-N has no influence to the global STO as well.

Local STO-Enable	String HW Enable	Local STO-Status	Safety acc. to SIL2	Drive can produce Torque
0 V	no	high	yes	no
0 V	yes	high	yes	no
+24 V	no	low	no	no
+24 V	yes	low	no	yes

When STO function is engaged during operation by separating input STO-Enable from 24 V, the connected motor slows down without control.

NOTICE

Use the following functional sequence when the STO function is used:

1. Brake the drive in a controlled manner (speed setpoint = 0 V).
2. When speed = 0 rpm, disable the drive (enable = 0 V).
3. If a suspended load is present, block the drive mechanically.
4. Activate the STO function.

NOTE

It is not possible to perform a controlled brake if the drive STO-Enable is off. If controlled braking prior to the use of the STO function is necessary, the drive must be braked first and the input STO must be separated from +24 V time-delayed.

7.13.11.1 Signal diagram (sequence)

The diagram below shows how to use STO function for a safe drive stop and fault free operation of the drive. This sequence is valid for local and global STO functionality.

1. Brake the drive in a controlled manner (speed setpoint = 0 V).
2. When speed = 0 rpm, disable the drive (Enable = 0 V).
3. Activate the STO function (local STO-Enable = 0 V)
4. For restart you must reset the safety device.

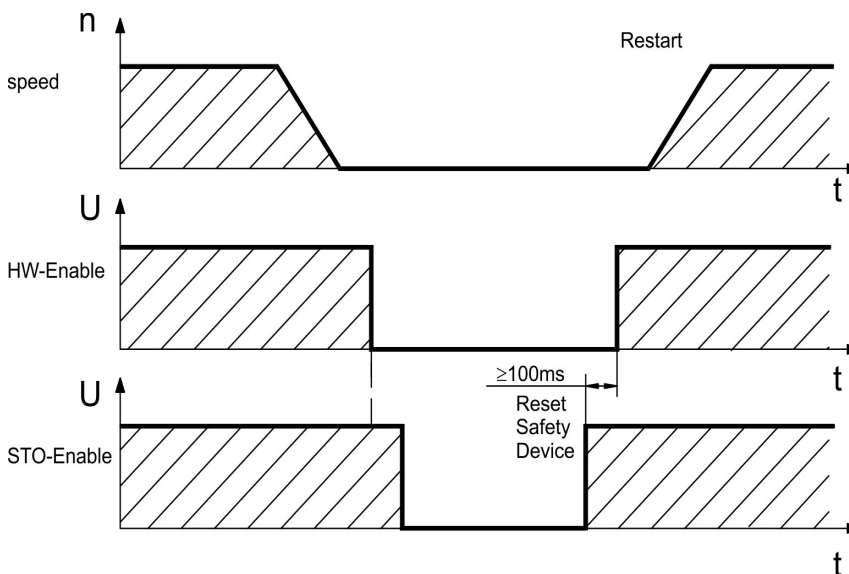

7.13.12 Functional test

NOTICE

You must test the safe torque off function after initial start of the drive, after each interference into the wiring of the drive, or after exchange of one or several components of the drive.

7.13.12.1 Global STO

Refer to the AKD-C respectively MKD-C Installation Manual for the functional test of global STO.

7.13.12.2 Local STO

First Method:

1. Stop the drive with setpoint 0 V. Keep drive enabled.
DANGER: Do not enter hazardous area!
2. Activate the local STO function for example by opening protective screen of the drive, (voltage at AKD-N X6/1 0V).
3. The drive lose torque and slows down to zero speed without control.

Second Method:

1. Stop the drive with setpoint 0 V, disable drive.
2. Activate the STO function, for example, by opening protective screen (voltage at AKD-N X6/1 0V)
3. The drive cannot be enabled.

7.13.12.3 Local STO application example

The sample application below shows door guarding and emergency stop, controlled by a safety control to switch the local STO-Enable input of an AKD-N-DS or DT drive according to SIL2, PLd.

NOTE Kollmorgen KSM modules cannot be used.

For detailed application examples refer to the *Decentralized System Project Guide*.

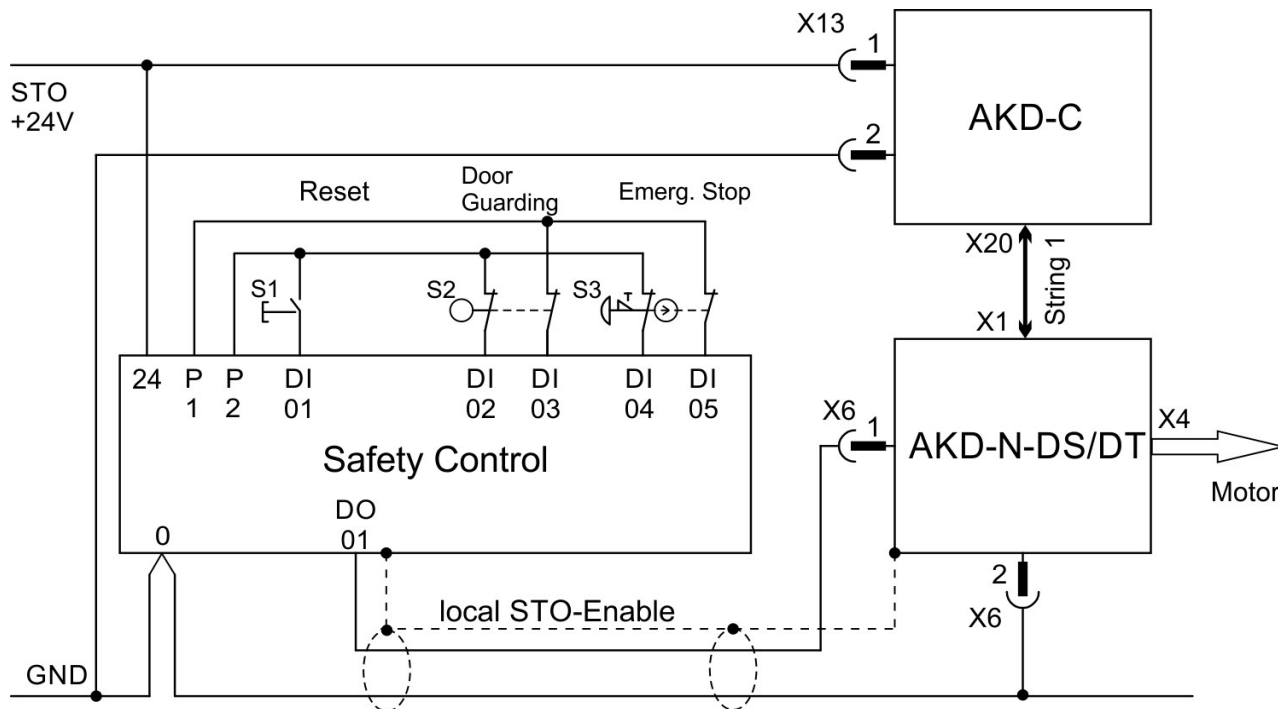

7.13.12.4 OSSD test pulses

Safety controllers usually check their outputs periodically during the normal operation. These test procedures create pulses to the AKD-N-DS/DT STO-Enable input.

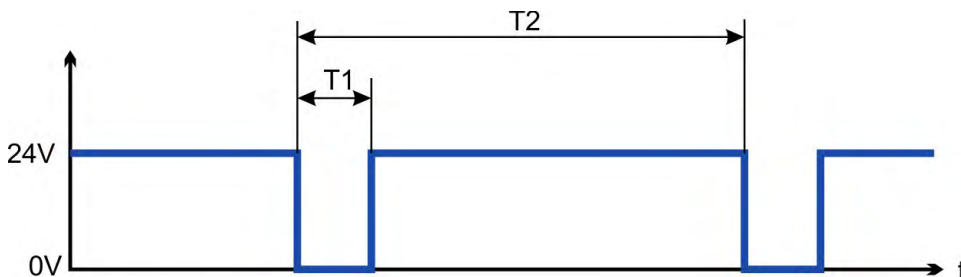

Test pulses with $T1 < 300 \mu s$ and $T2 > 200 ms$ will not have any influence to the safety relevant STO function. Test pulses, which are outside of this specification, will switch the STO function, but will not create a dangerous situation.

8 Mechanical Installation

8.1 Important Notes	51
8.2 Temperature Management	51
8.3 Mechanical Drawings	52

8.1 Important Notes



CAUTION High EMC Voltage Level!

Risk of electrical shock, if drive (or motor) is not properly EMC-grounded.

- Do not use painted (i.e. non-conductive) mounting plates.
- Use both PE connections.
- To keep impedance as low as possible, we recommend copper earthing straps for the PE connections.



CAUTION High Temperature!

Risk of light burns. The housing of the drive can reach temperatures up to 80°C in operation.

- Measure the temperature, and wait until the housing has cooled down below 40°C before touching it.
- Ensure free space of minimum 50 mm to all sides of the AKD-N.

NOTICE

Protect the drive from impermissible stresses. In particular, do not let any components become bent or any insulation distances altered during transport and handling. Avoid contact with electronic components and contacts.

NOTICE

The drive will switch itself off in case of overheating. Ensure that the mounting space matches the requirements (→ # 29).

NOTICE

Do not mount devices that produce magnetic fields directly beside the drive. Strong magnetic fields can directly affect internal components. Install devices which produce magnetic field with distance to the drives and/or shield the magnetic fields.

NOTE

An optimized thermal strategy is mandatory for AKD-N performance. Observe the information given in the Decentralized System Project Guide and in chapter (→ # 51)

8.2 Temperature Management

The possible continuous output current and output power depends on the cooling situation for the AKD-N. For a detailed calculation of temperature behavior of the decentralized drive system based on the special machinery architecture, contact the Kollmorgen customer support.

Optimum cooling situation to reach rated power:

Cold plate requirements with 40°C surrounding temperature at 680 VDC supply voltage:

- AKD-N 03 A: cold plate 350 mm x 350 mm x 10 mm
- AKD-N 06 A: cold plate 500 mm x 500 mm x 10 mm
- AKD-N 12 A: heat sink 480 mm x 400 mm x 84 mm, 31 fins

For a rough overview the three level rating below may help.

1. Optimum cooling situation: Cold plate / heat sink size definition fulfilled, no additional heat sink required
2. Bad cooling situation: Example: 50% cooling plate available
Use the optional big heat sink (50 mm height) to reach optimum situation.

The heat sink variants are described in the regional accessories manual.

8.3 Mechanical Drawings

8.3.1 Dimensions AKD-N, preferred mounting

Material:

- Four mounting clamps (part of delivery)
- Four M5 hexagon socket screws to ISO 4762, use 4 mm T-handle Allen key
- Heat conducting film AKD-N003/006 (order code 849-373000-04)
- Heat conducting film AKD-N012 (order code 849-374001-04)

NOTE Ensure free space of minimum 50 mm to all sides of the AKD-N.

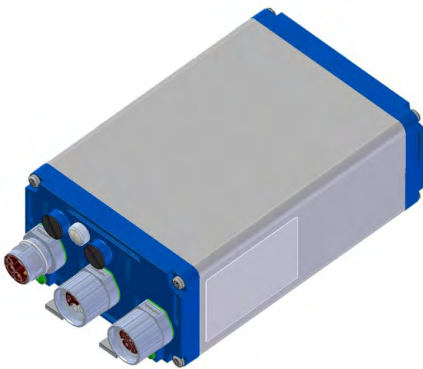
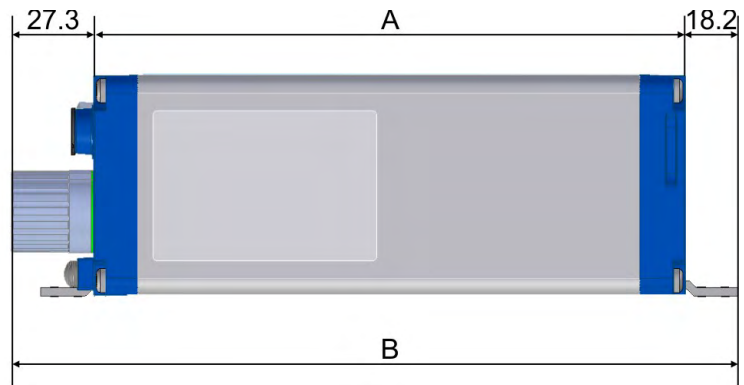
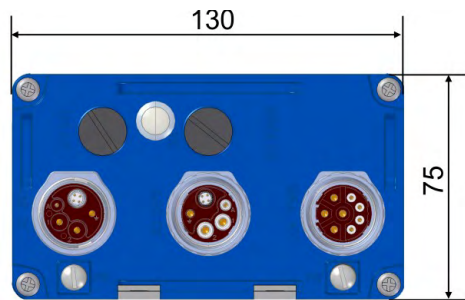

Drill plan,
preferred mounting

	A	B	C
AKD-N003/006	201.0	246.5	220.0
AKD-N012	251.5	297.0	270.0

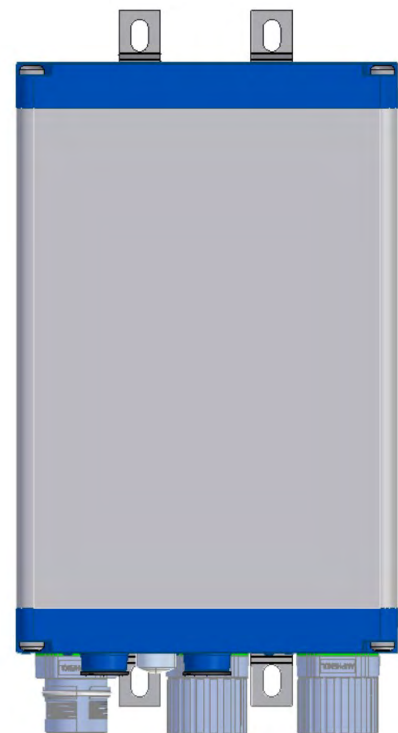
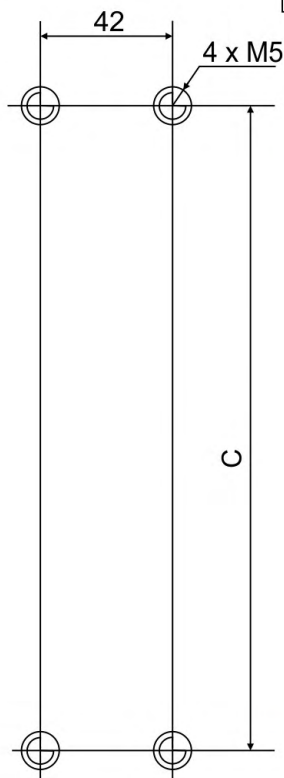

4 Mounting Clamps

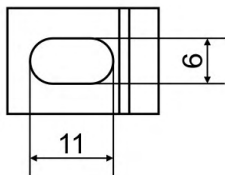
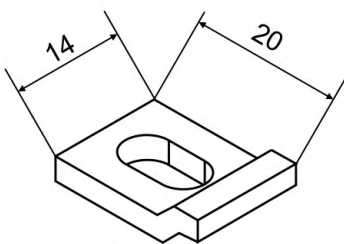

8.3.2 Dimensions AKD-N with optional heat sink, preferred mounting

Material:

- Four mounting clamps (part of delivery)
- Four M5 hexagon socket screws to ISO 4762, use 4 mm T-handle Allen key
- Four M4x16 hexagon socket screws to ISO 4762 (part of delivery), use 3 mm T-handle Allen key
- Heat conducting film AKD-N003/006 (order code 849-373000-04)
- Heat conducting film AKD-N012 (order code 849-374001-04)
- Heat sink 50 mm (option, see regional Accessories Manual), for all AKD-N types

NOTE

Ensure free space of minimum 50 mm to all sides of the AKD-N.

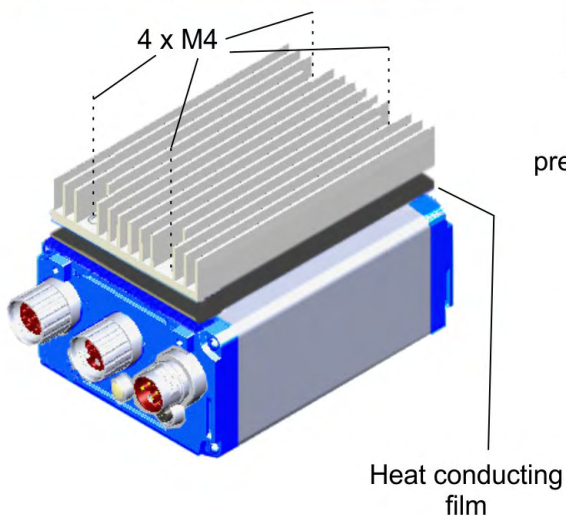
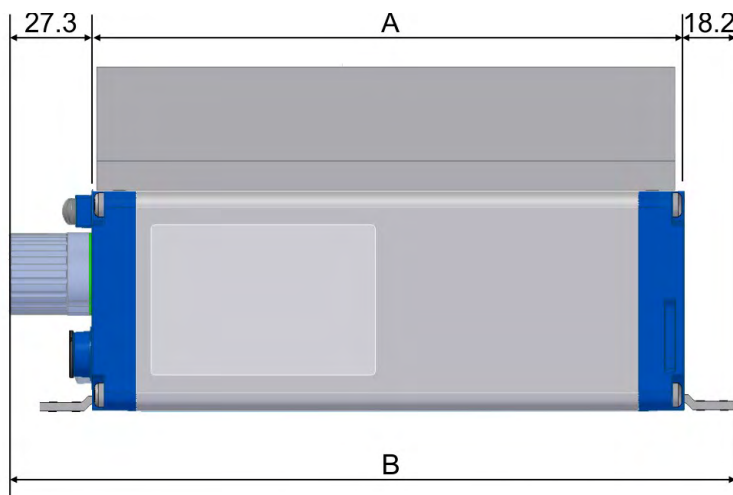
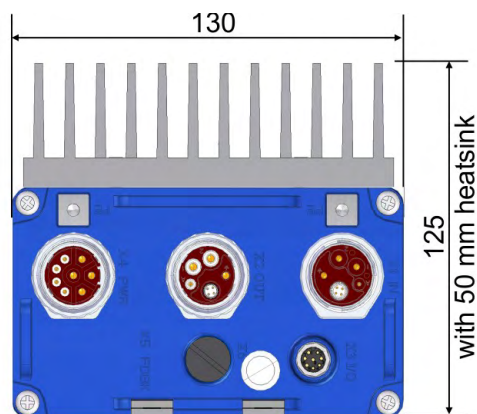

Drill plan, preferred mounting

	A	B	C
AKD-N003/006	201.0	246.5	220.0
AKD-N012	251.5	297.0	270.0

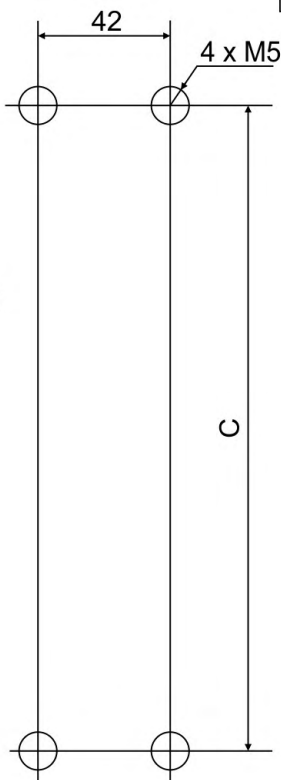

4 Mounting Clamps

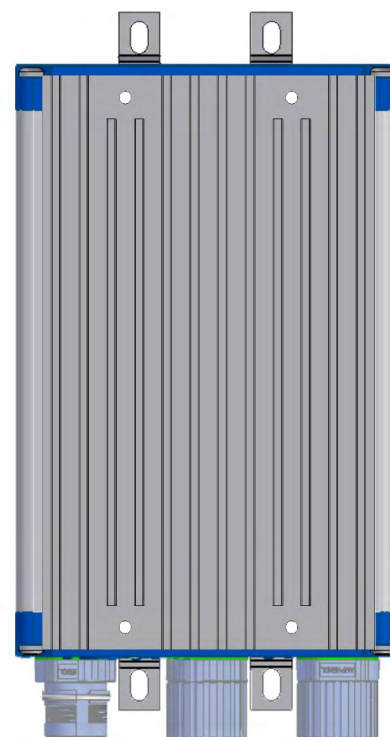
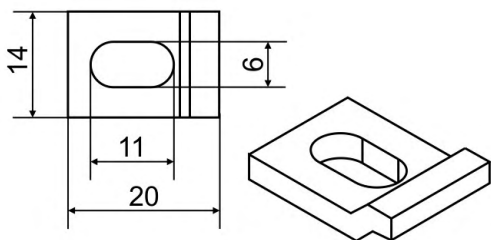

9 Electrical Installation

9.1 Important Notes	55
9.2 Guide to Electrical Installation	56
9.3 System Topology of a Decentralized Servo System	57
9.4 Wiring	59
9.5 Connection Overview	60
9.6 Hybrid Connection (X1, X2)	65
9.7 I/O Connection (X3)	65
9.8 Motor Power Connection (X4)	68
9.9 Motor Brake Connection (X4)	69
9.10 Motor Feedback Connection (X4, X5)	71
9.11 Optional Connector (X6)	73

9.1 Important Notes

NOTICE

Only professional staff who are qualified in electrical engineering are allowed to install the drive. Wires with color green with one or more yellow stripes must not be used other than for protective earth (PE) wiring.



⚠ DANGER High Voltage up to 900 V!

There is a danger of serious personal injury or death by electrical shock or electrical arcing. Contacts can still have dangerous voltage present up to 7 minutes after switching off mains voltage.

Control and power connections can still be live, even if the motor is not rotating. The built-in LED does **not** indicate the real voltage level.

- Only install and wire the equipment when it is not live, that is, when neither the electrical supply nor the 24 V auxiliary voltage nor the supply voltages of any other connected equipment is switched on.
- Make sure that the cabinet is safely disconnected (for instance, with a lock-out and warning signs).
- Never remove electrical connections to the AKD-N while it is live.
- Wait at least 7 minutes after disconnecting the AKD-C/MKD-C from all power supply sources before touching potentially live sections of the equipment (e.g. contacts) or undoing any connections.
- Always measure the voltage in the DC bus link at X14 on AKD-C respectively at X23 on MKD-C and wait until the voltage is below 50 V before handling components.

NOTICE

Since the leakage current to PE is more than 3.5 mA, in compliance with IEC 61800-5-1 the PE connection must either be doubled or a connecting cable with a cross-section >10 mm² must be used. There is a danger of electrical shock with possible personal injury. Deviating measures according to regional standards might be possible.

NOTICE

Wrong DC Bus link voltage, unsuitable motor or wrong wiring will damage the drive. Check the combination of drive and motor. Compare the rated voltage and current of the units. Implement the wiring according to the connection diagrams: (→ # 60).

It is permissible to use the setup software to alter the settings of the drive. Any other alterations will invalidate the warranty.

9.2 Guide to Electrical Installation

Install the drive electrical system as follows:

1. Select cables (→ # 31) in accordance with the planned system topology (→ # 57).
2. Install grounding (PE) and ground the drive.
Ground the mounting plate, motor housing and CNC-GND of the control system.
3. Wire the drive:

NOTICE

The connectors are close to each other on the drive. To ensure simple handling, observe the connector mounting sequence: X2 - X1 - X4 - X5 - X3 - X6

- Connect the hybrid power cable between AKD-C/MKD-C X20 or X21 and AKD-N X1, max. length 40 m.
 - Connect the hybrid power cables between the AKD-N drives X1/X2, max. length 25 m.
 - Dual cable connection:
Connect the motor cable to X4, max. length 5 m.
Connect the feedback device to X5, max. length 5 m.
 - Single cable connection:
Connect the hybrid motor cable to X4, max. length 5 m.
4. Check the wiring against the planned system topology diagrams (→ # 57).

9.3 System Topology of a Decentralized Servo System

9.3.1 System limits

String length:	Maximum 100 m total cable length per string.
Number of AKD-N:	<ul style="list-style-type: none"> ● AKD-C: max. 8 per string. ● MKD-C: max. 14 per string. <p>Observe system restrictions described in the <i>Decentralized System Project Guide</i>.</p>
String current:	<ul style="list-style-type: none"> ● AKD-C: sum of string 1 and 2 max. 17 A. ● MKD-C: max. 16 A per string. <p>Calculate coincidence factor of the axes</p>
String power:	<ul style="list-style-type: none"> ● AKD-C: sum of string 1 and 2 max. 11 kW. ● MKD-C: 10 kW per string. <p>Calculate coincidence factor of the axes.</p>
Standby Power:	<ul style="list-style-type: none"> ● AKD-C: sum of string 1 and 2 max. 260 W at 24 V. ● MKD-C: max. 180 W at 24 V per string.

9.3.2 Example with AKD-C

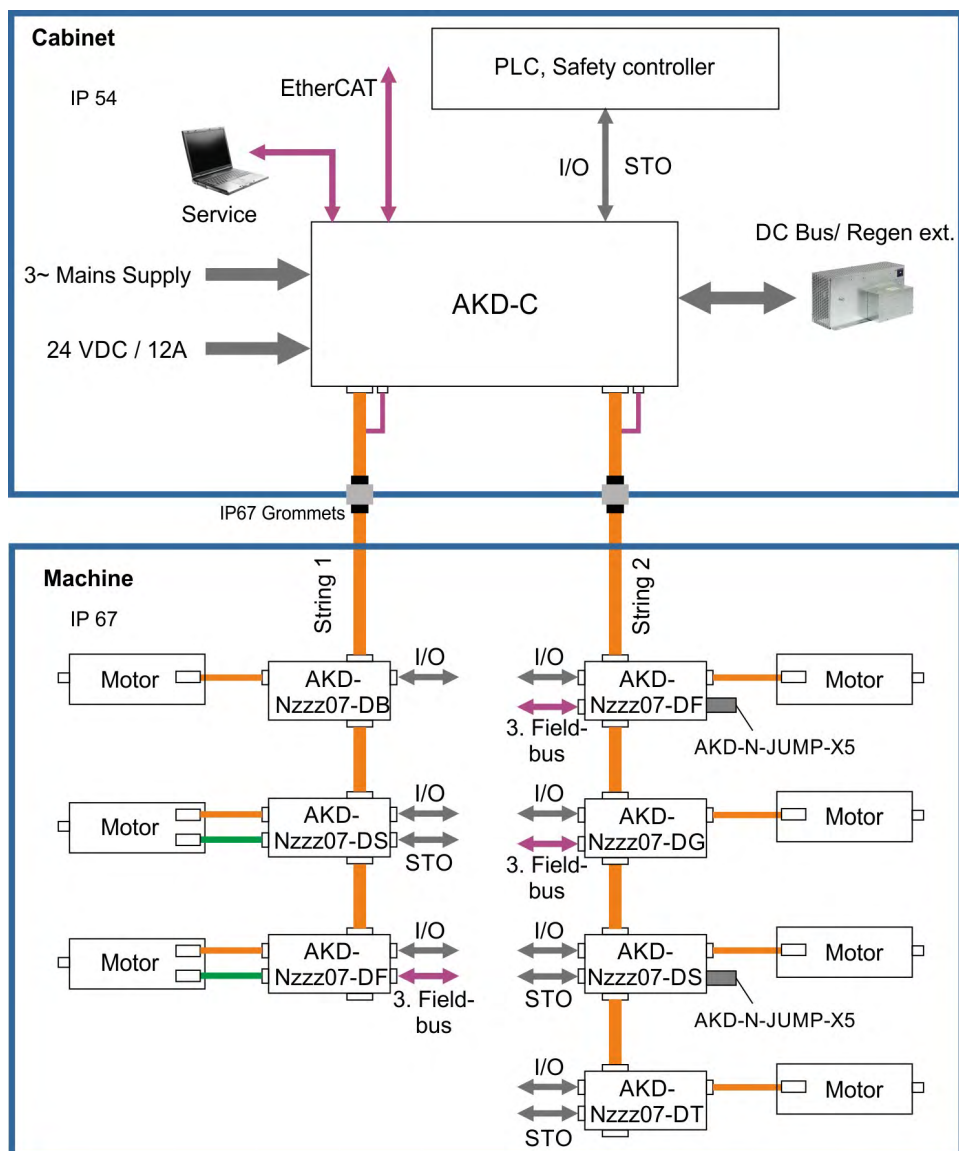

9.3.3 Example with MKD-C

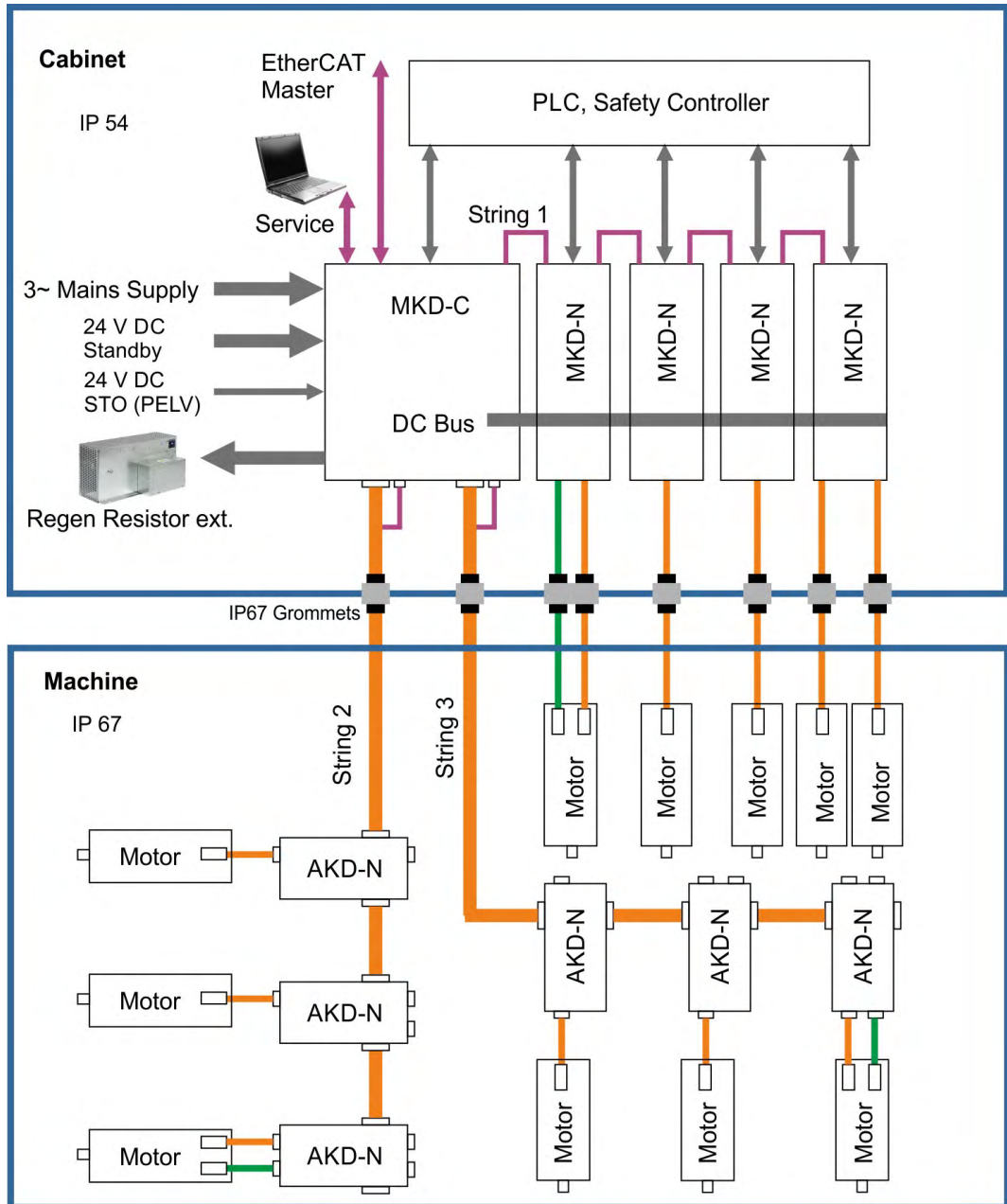

9.4 Wiring



DANGER High Voltage up to 900 V!

There is a danger of serious personal injury or death by electrical shock or electrical arcing.

The built-in LED does **not** indicate the real voltage level.

- Only install and wire the equipment when it is not live, that is, when neither the electrical supply nor the 24 V auxiliary voltage nor the supply voltages of any other connected equipment is switched on.
- Make sure that the cabinet is safely disconnected (for instance, with a lock-out and warning signs). The individual voltages are switched on for the first time during setup.

NOTICE

Only professional staff who are qualified in electrical engineering are allowed to install the drive. Wires with color green with one or more yellow stripes must not be used other than for protective earth (PE) wiring. When installing or replacing cables, use only standardized components, which complies to the specifications in chapter 7.8 "Cable Requirements".

NOTE

The ground symbol, which you will find in all the wiring diagrams, indicates that you must take care to provide an electrically conductive connection with the largest feasible surface area between the unit indicated and the mounting plate in the control cabinet. This connection is for the effective grounding of HF interference, and must not be confused with the PE-symbol (PE = protective earth, safety measure as per IEC 60204).

Use the following connection diagrams:

Overview AKD-N variant DB	(→ # 62)
Overview AKD-N variant DG/DT	(→ # 63)
Overview AKD-N variant DF/DS	(→ # 64)
Hybrid connection (DC power and Fieldbus)	(→ # 65)
Digital inputs and outputs	(→ # 65)
Motor Power	(→ # 68)
Motor Brake	(→ # 69)
Motor Feedback	(→ # 71)
Tertiary motion bus interface	(→ # 73)
Local STO	(→ # 73)

9.5 Connection Overview

9.5.1 Connector assignment AKD-Nzzz07-DB

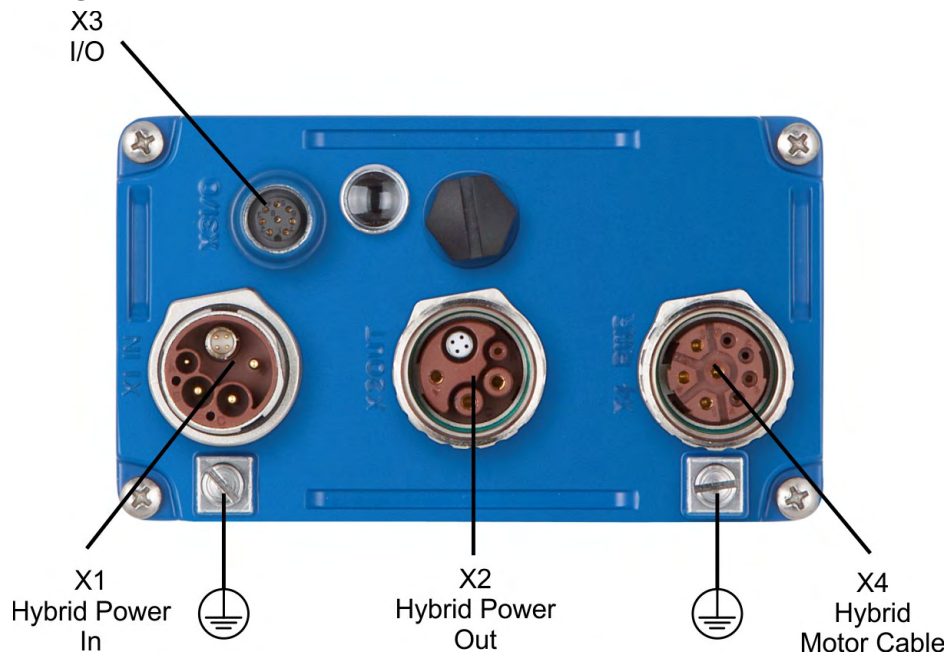

9.5.2 Connector assignment AKD-Nzzz07-DG/DT

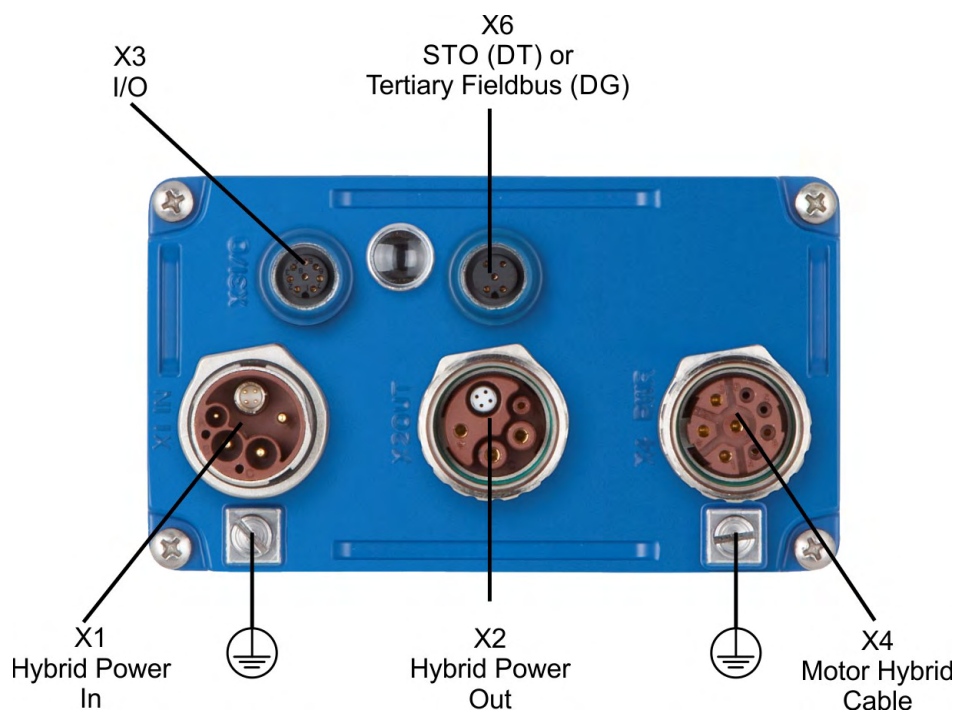

9.5.3 Connector assignment AKD-Nzzz07-DF/DS

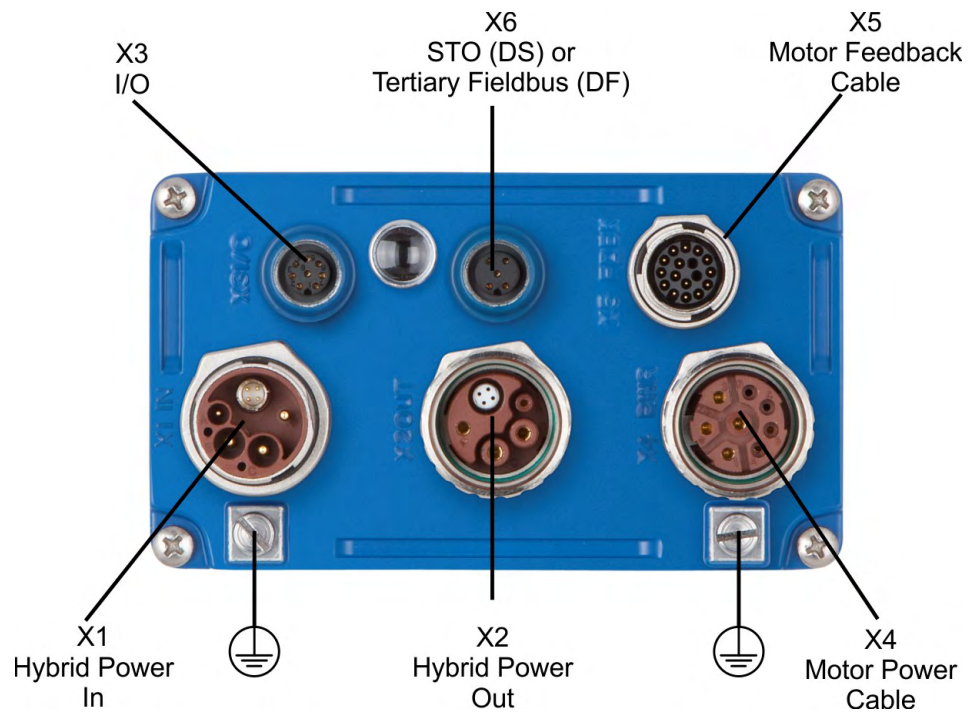

9.5.4 Connection diagram with MKD-C

For connection to MKD-C power supply refer to the *MKD-C Multi Axes Installation Manual*.

9.5.5 Connection diagram AKD-Nzzz07-DB with AKD-C

Reference Safety Instructions and Use As Directed

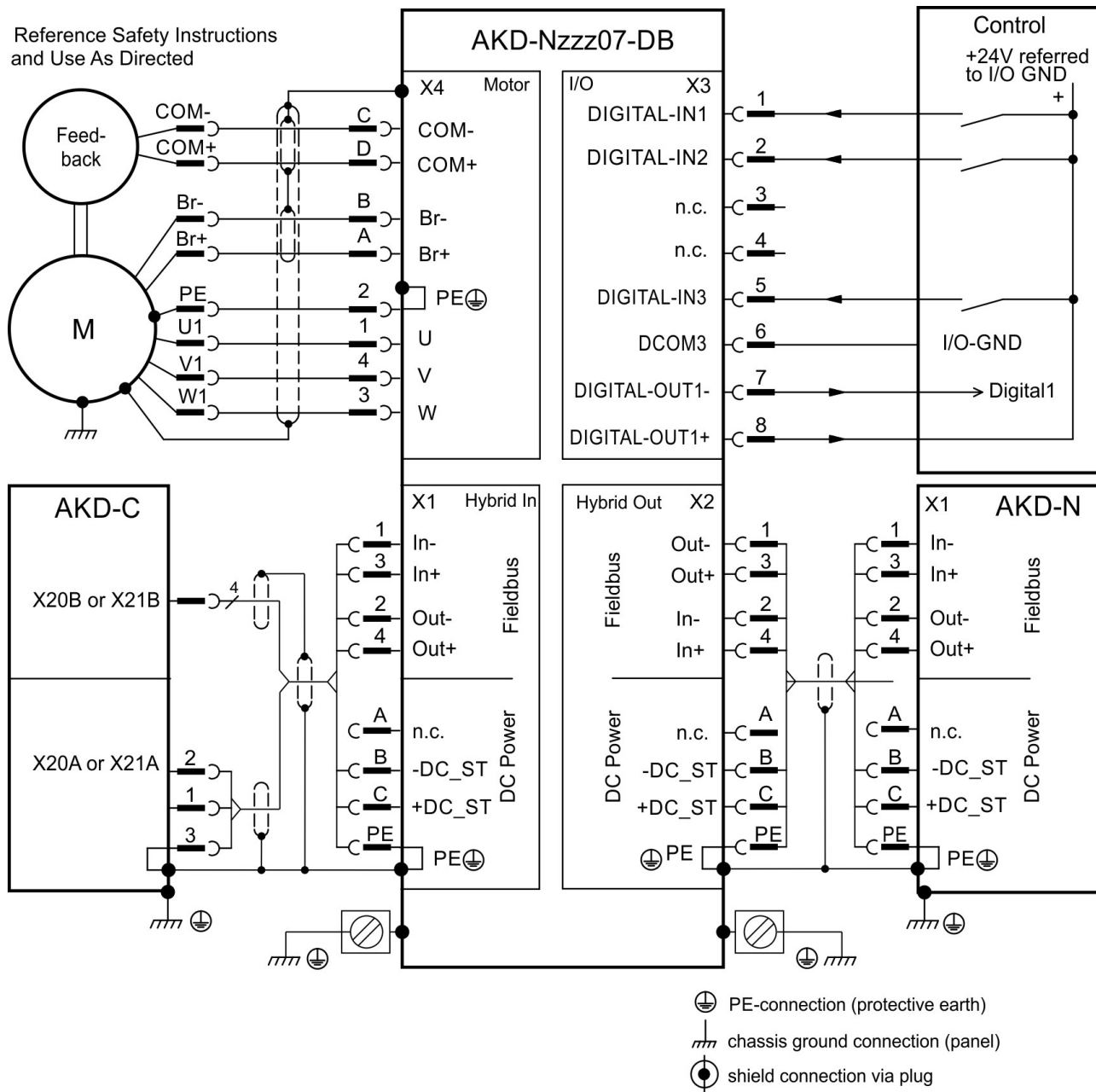

9.5.6 Connection diagram AKD-Nzzz07-DG/DT with AKD-C

Reference Safety Instructions and Use As Directed

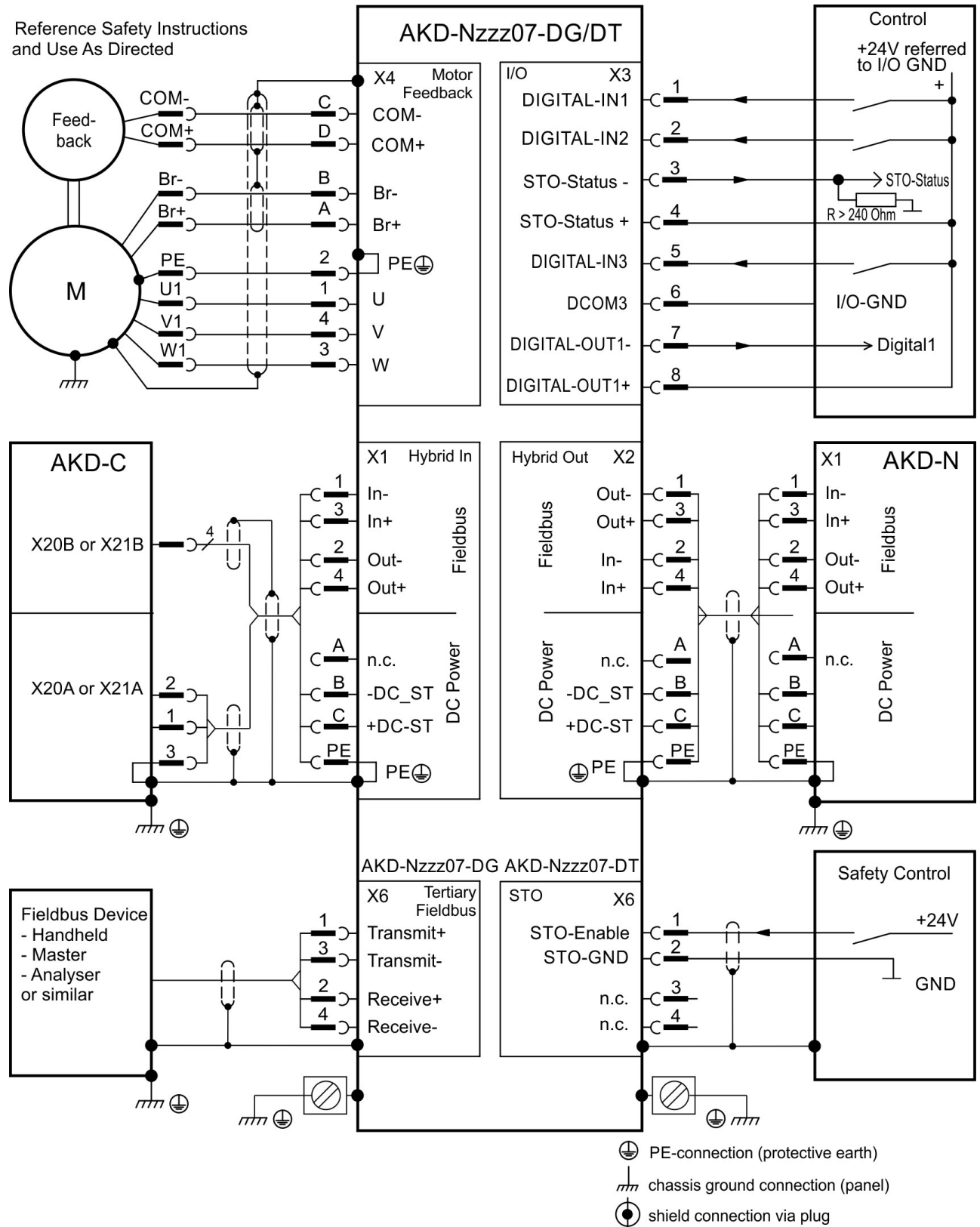

9.5.7 Connection diagram AKD-Nzzz07-DF/DS with AKD-C

Reference Safety Instructions and Use As Directed

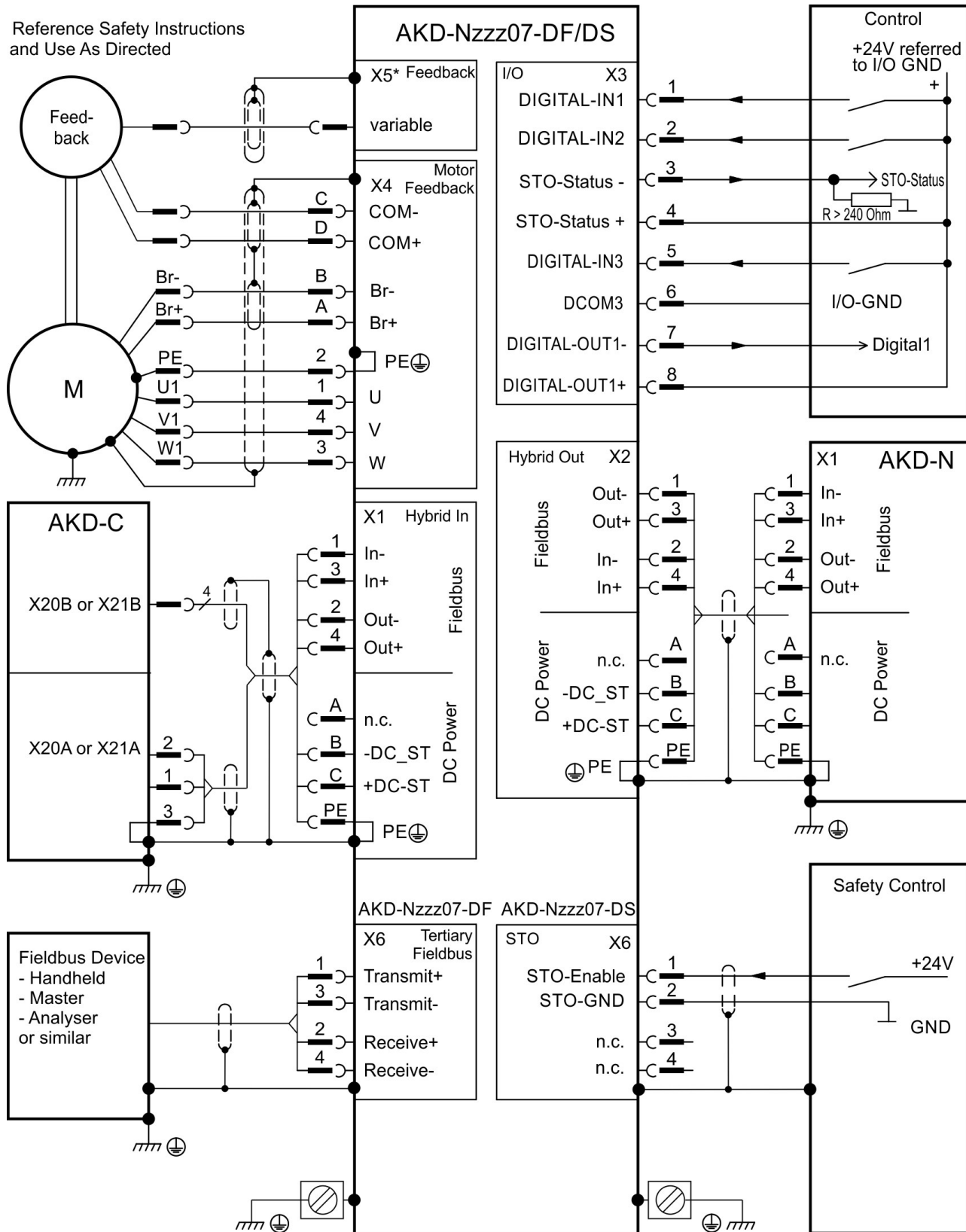

* In case of single line connection to the motor:
 For sufficient voltage supply of the feedback system connected to X4, the connector AKD-N-JUMP-X5 must be plugged to X5.

- PE-connection (protective earth)
- chassis ground connection (panel)
- shield connection via plug

9.6 Hybrid Connection (X1, X2)

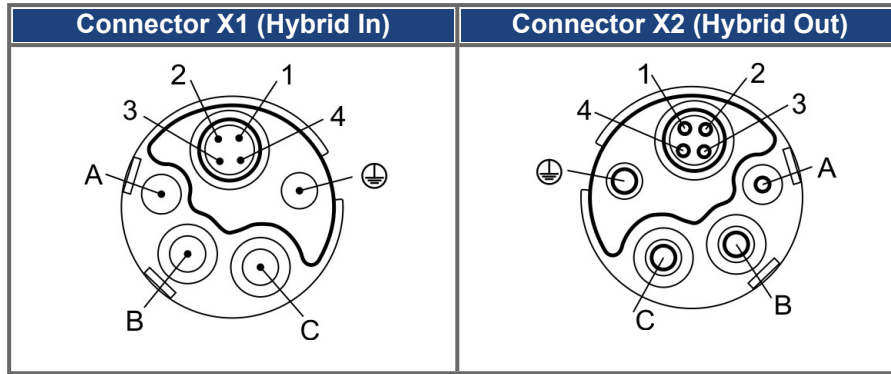

Pinout

Pin	Usage X1	Usage X2
A	not connected	not connected
B	- DC_ST	- DC_ST
C	+DC_ST	+DC_ST
PE	PE	PE
1	Receive -	Transmit -
2	Transmit -	Receive -
3	Receive +	Transmit+
4	Transmit +	Receive +

9.7 I/O Connection (X3)

M12, A-coded	X3	Description	Abbreviation	Function
	1	Digital Input 1	DIGITAL-IN 1	Programmable
	2	Digital Input 2	DIGITAL-IN 2	Programmable
	3*	STO-Status -	STO-Status -	local STO-Status
	4*	STO-Status +	STO-Status +	local STO-Status
	5	Digital Input 3	DIGITAL-IN 3	Programmable
	6	Digital Common	DCOM3	Common line for pins 1, 2, 5
	7	Digital Output 1-	DIGITAL-OUT1-	Programmable
	8	Digital Output 1+	DIGITAL-OUT1+	Programmable

* STO-Status signals are available for AKD-N with option "DS" only.

The DCOM3 line should be connected to the 0V of the I/O supply when using sensors of type "Source" with digital inputs.

The DCOM3 line should be connected to the 24V of the I/O supply when using sensors of type "Sink" with digital inputs.

9.7.1 Digital Inputs

The drive provides 3 digital inputs. These can be used to initiate pre-programmed functions that are stored in the drive. A list of these pre-programmed functions is included in the WorkBench. If an input is programmed, it must be saved to the drive. By default, all inputs are not programmed (off). For more information refer to the setup software.

NOTE

Depending on the selected function, the inputs are high or low active. The inputs can be used with switched +24 V (source type) or switched GND (sink type). Digital input filter can be set in WorkBench to change sensitivity of the inputs (see Online Help).

Wiring diagram:

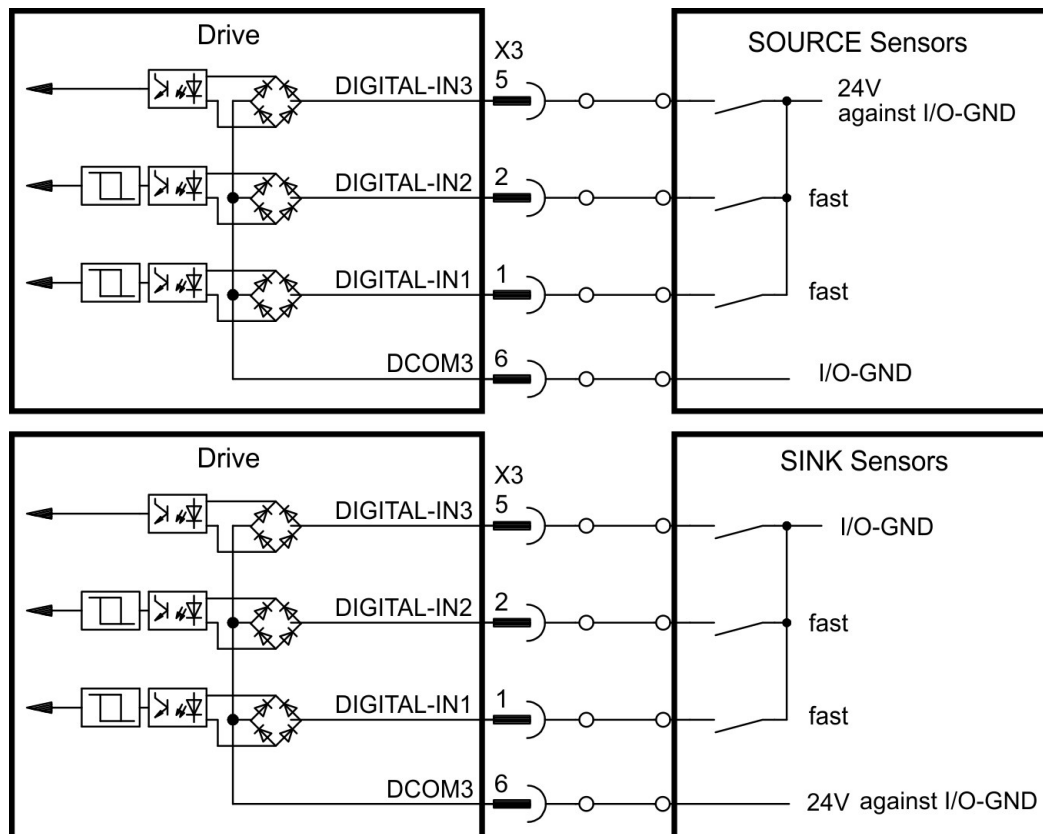

Digital Inputs 1 and 2

These inputs are particularly fast and are therefore suitable for latch functions, for example.

Technical characteristics:

- Floating, reference common line is DCOM3
- Sink or Source type sensors possible
- High: 15 to 30 V / 2 to 15 mA , Low: -3 to +5 V / <1 mA
- Update rate: firmware reads hardware input state every 250 μ s
- High accuracy latch: motor feedback position or interpolated time is latched or captured within 2 μ s of input signal transition (with digital input filter set to 40 ns)
- The AKD-N capture engine is polled every 62.5 μ s (16 kHz) by the firmware

Digital Input 3

Choose the function you require in WorkBench.

Technical characteristics:

- Floating, reference common line is DCOM3
- Sink or Source type sensors possible
- High: 15 to 30 V / 2 to 15 mA , Low: -3 to +5 V / <1 mA
- Update rate: firmware reads hardware input state every 250 μ s

9.7.2 Digital Output

The drive supplies one programmable digital output and the permanent STO-Status output for drives with "DS" option. For the programmable output choose the required function in the setup software. Messages from pre-programmed functions stored in the drive can be output here. A list of these pre-programmed functions can be found in the setup software. If an output is to be assigned to a pre-programmed function, then the parameter set must be saved in the drive. By default, the output is not programmed (off). For more information refer to the setup software.

Technical characteristics:

- STO-Status signal is available for AKD-N with option "DS" only.
- 24 V , 20 VDC to 30 VDC
- All digital outputs are floating, max. 100 mA
- Can be wired as active low or active high (see examples below)
- Update rate: 250 μ s

Wiring diagram:

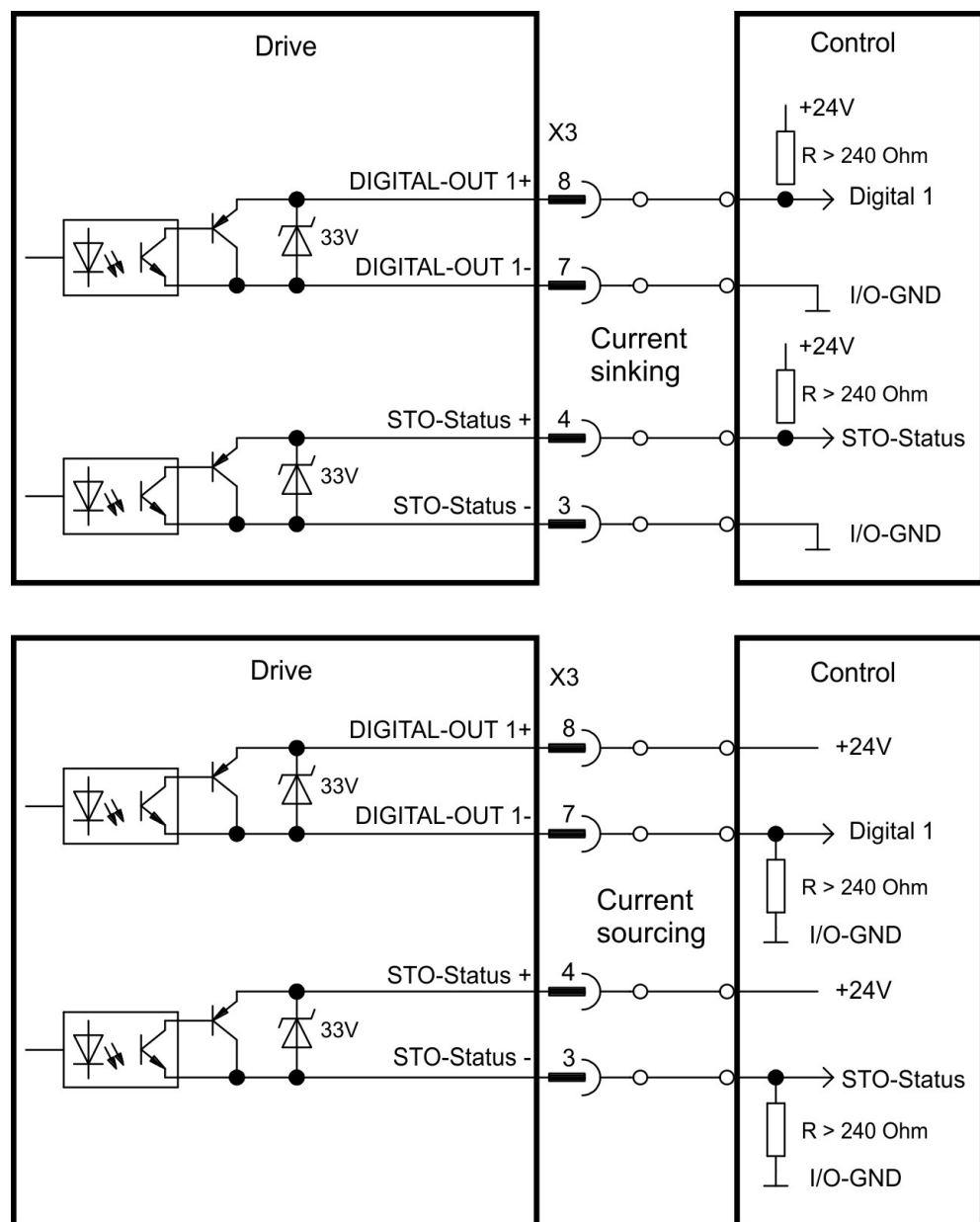

9.8 Motor Power Connection (X4)

Together with the motor supply cable and motor winding, the power output of the drive forms an oscillating circuit. Characteristics such as cable capacity, cable length, motor inductance, and frequency determine the maximum voltage in the system.

The AKD-N drive is able to protect the connected motor from overloading, if the parameters are set correctly and the thermal protection sensor is connected and supervised. With Kollmorgen motors the valid data are automatically set by the internal motor database. With motors from other manufacturers the data from the nameplate must be entered to the referring fields in the motor view of the Kollmorgen setup software WorkBench. Refer to parameter MOTOR.RTYPE for supported thermal sensors.

NOTICE

The dynamic voltage rise can lead to a reduction in the motor operating life and, on unsuitable motors, to flashovers in the motor winding.

- Only install motors with insulation class F (acc. to IEC60085) or above.
- Only install Kollmorgen cables that meet the requirements (→ # 31).

9.8.1 Connector X4 AKD-Nzzz07 all variants, hybrid, single cable

Motors with single cable connection (motor power lines, motor holding brake lines and motor feedback lines combined in one hybrid cable) can be connected to X4 of all AKD-N variants.

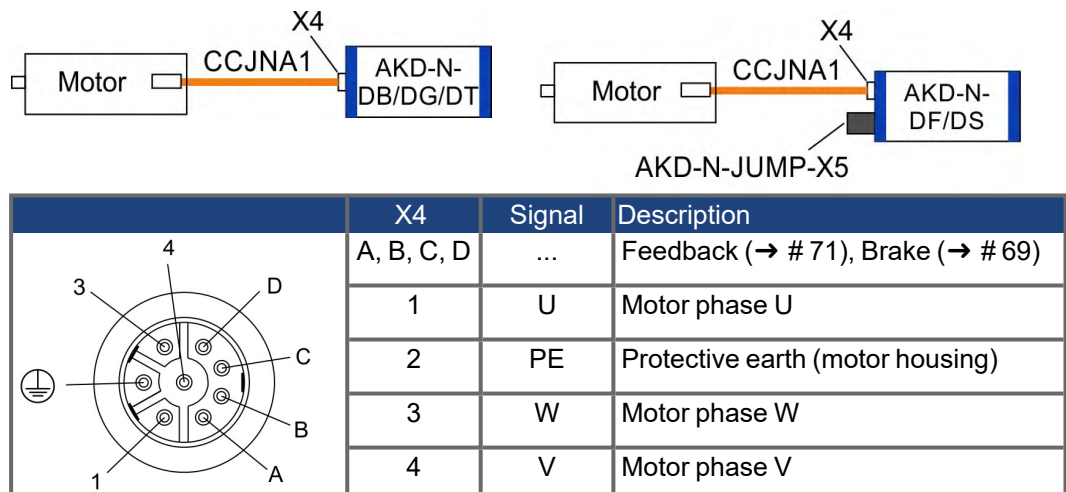

9.8.2 Connector X4 AKD-Nzzz07-DF/DS, dual cables

Motors with dual cables connection (motor power lines and motor holding brake lines in one cable, motor feedback lines in a separate cable) can be connected to X4 and X5 of the AKD-Nzzz07-DF and -DS variants.

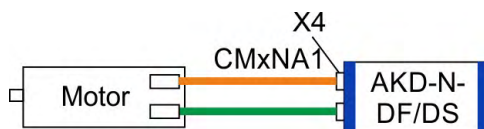

	X4	Signal	Description
	A, B, C, D	...	Brake (→ # 69)
	1	U	Motor phase U
	2	PE	Protective earth (motor housing)
	3	W	Motor phase W
	4	V	Motor phase V

9.9 Motor Brake Connection (X4)

A 24 V holding brake in the motor can be controlled directly by the drive. The brake only works with sufficient 24 V voltage level. Check voltage drop, measure the voltage at brake input and check brake function (brake and no brake). Maximum current for the motor brake is 1 A with AKD-N00307 and 1.5 A with AKD-N00607 or AKD-N-N01207.

NOTE

The stand-by power supply from AKD-C/MKD-C limits the number of brakes in the system. Observe the projecting hints for system topology and limits in the *Project Guide*.



CAUTION No Functional Safety!

Serious injury could result when a suspended load is not properly blocked. Functional safety requires and additional, external mechanical brake, operated by a safety controller.

- Add a safe mechanical blocking (for instance, a motor-holding brake).
- Set parameter MOTOR.BRAKEIMM to 1 with vertical axes, to apply the motor holding brake immediately after faults or Hardware Disable.

The brake function must be enabled and configured with parameter using WorkBench, for details refer to the online help.

Single cable hybrid cable and dual cable motor power cable use two wires for motor holding brake connection.

Single Cable

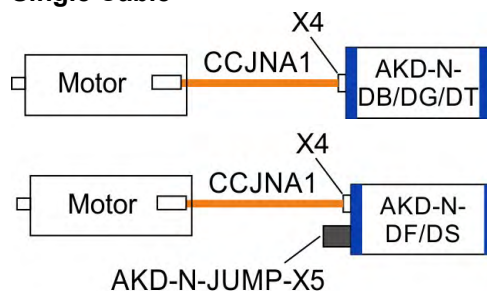

Dual Cable

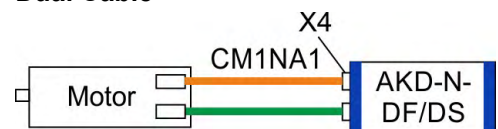

	X4	Signal	Description
	A	+BR	Motor holding brake, positive
	B	-BR	Motor holding brake, negative
	C, D	...	Single Cable: Feedback (→ # 71) Dual Cable: unused
	1,2,3,4	...	Motor power (→ # 68)

9.10 Motor Feedback Connection (X4, X5)

Every closed servo system normally requires at least one feedback device for sending actual values from the motor to the drive. Depending on the type of feedback device used, information will be fed back to the drive using digital or analog means.

AKD-N supports the most common types of feedback device. Feedback functions are assigned with parameters in WorkBench, the setup software. Scaling and other settings are also performed in WorkBench. For a detailed description of the parameters, please refer to the WorkBench online help.

Motors with single cable connection (motor power lines, motor holding brake lines and motor feedback lines combined in one hybrid cable) can be connected to X4 of all AKD-Nzzz07 variants.

NOTICE

AKD-Nzzz07-DS/DF with single cable connection: For sufficient voltage supply of the feedback system connected to X4, a special connector must be plugged to X5 to connect pins 4 and 5. This special connector is available with order code **AKD-N-JUMP-X5**.

Motors with dual cable connection (motor power lines and motor holding brake lines in one cable, motor feedback lines in a separate cable) can be connected to X4 and X5 of the AKD-Nzzz07-DF and -DS variants.

9.10.1 Connector X4 AKD-Nzzz07 all variants, hybrid, single cable

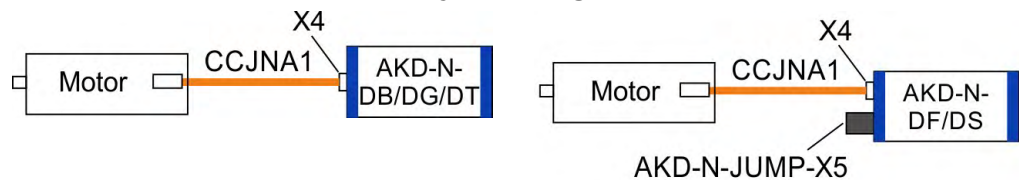

NOTE

Support for SFD3 and Hiperface DSL feedback systems.

	X4	Signal	Description
	A,B	...	Brake (→ # 69)
	C	COM-	Feedback, negative
	D	COM+	Feedback, positive
	1,2,3,4	...	Motor power (→ # 68)
Maximum cable length	5 m		

9.10.2 Connector X5 AKD-Nzzz07-DF/DS, dual cable

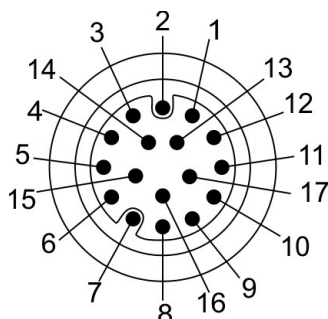
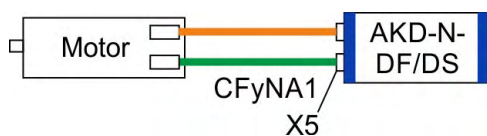

X5	SFD (4 lines)	BiSS B (analog)	BiSS C (digital)	EnDAT 2.1	EnDAT 2.2	Hiperface	Sine Enc. +Hall	Incr. Enc. +Hall
1	-	-	-	-	-	-	Hall U	Hall U
2	-	CLK+	CLK+	CLK+	CLK+	-	Hall V	Hall V
3	-	CLK-	CLK-	CLK-	CLK-	-	Hall W	Hall W
4	-	-	-	-	-	*1	-	-
5	-	-	-	-	-	*1	-	-
6	COM+	DAT+	DAT+	DAT+	DAT+	DAT+	Zero+	Zero+
7	COM-	DAT-	DAT-	DAT-	DAT-	DAT-	Zero-	Zero-
8	-	Th+	-	Th+	-	Th+	Th+	Th+
9	-	Th-	-	Th-	-	Th-	Th-	Th-
10	+5 V	+5 V	+5 V	+5 V	+5 V	+8 to +9 V	+5 V	+5 V
11	0 V	0 V	0 V	0 V	0 V	0 V	0 V	0 V
12	-	A+	-	A+	-	SIN+	A+	A+
13	-	A-	-	A-	-	SIN-	A-	A-
14	-	B+	-	B+	-	COS+	B+	B+
15	-	B-	-	B-	-	COS-	B-	B-
16								
17								
Max. cable length	5 m							

CLK = CLOCK, DAT = DATA, Th = thermal control
 BiSS Mode C interface from Renishaw (model Resolute RA26B)
 Hiperface *1=pins 4 and 5 externally connected

9.11 Optional Connector (X6)

9.11.1 Pinout AKD-Nzzz07-DF/DG

The additional connector X6 with AKD-N-DF/DG device variants allows connection to fieldbus slave devices that are controlled by the system master.

Wiring diagram tertiary fieldbus

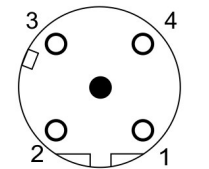
M12, D-coded	X6	Description
	1	Transmit +
	2	Receive +
	3	Transmit -
	4	Receive -

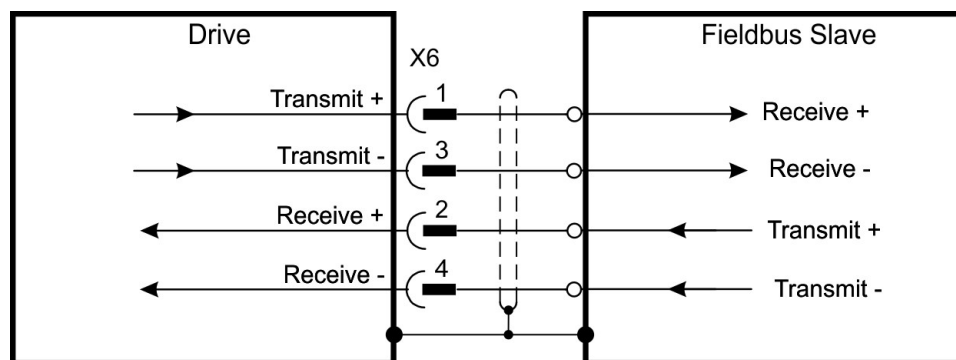

9.11.2 Pinout AKD-Nzzz07-DS/DT

An additional digital input (STO-Enable) releases the power output stage of the drive as long as a 24 V signal is applied to this input. The local STO-Enable input is galvanically isolated and need external 24 VDC supply (PELV/SELF).

For detailed description of STO interface and functionality refer to (→ # 42).

Wiring diagram local STO-Enable

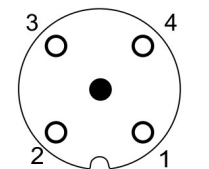
M12, A-coded	X6	Description
	1	STO-Enable +
	2	STO-Enable -
	3	n.c.
	4	n.c.

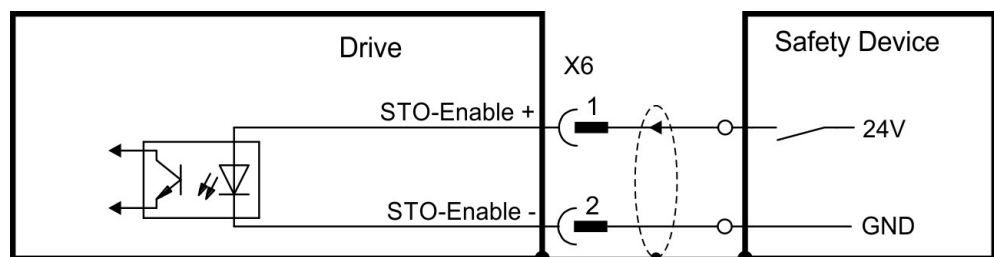

10 Setup

10.1 Important Notes	75
10.2 WorkBench Installation	76
10.3 Initial System Test	77
10.4 Fault and Warning Messages	78

10.1 Important Notes

NOTE

Before testing and setup, the manufacturer of the machine must generate a risk assessment for the machine and take appropriate measures so that unforeseen movements cannot cause injury or damage to any person or property.

NOTICE

Only professional personnel with extensive knowledge in the fields of electrical engineering and drive technology are allowed to test and set up the drive.



DANGER Lethal Voltage!

There is a danger of serious personal injury or death by electrical shock. Lethal danger exists at live parts of the device.

- Built-in protection measures such as insulation or shielding may not be removed.
- Work on the electrical installation may only be performed by trained and qualified personnel, in compliance with the regulations for safety at work, and only with switched off mains supply, and secured against restart.
- In normal operation, the cabinet door must be closed and the device must not be touched.



WARNING Automatic Restart!

Risk of death or serious injury for humans working in the machine. The drive might restart automatically after power on, voltage dip or interruption of the supply voltage, depending on the parameter setting. If parameter DRV.ENDEFAULT is set to 1,

- then place a warning sign ("WARNING: Possible Automatic Restart" or similar) to the machine.
- Ensure, that power on is not possible, while humans are in a dangerous zone of the machine.



CAUTION High Temperature!

Risk of minor burns. The heat sink of the drive can reach temperatures up to 80°C in operation.

- Check the heat sink temperature before handling the drive.
- Wait until the heat sink has cooled down to 40°C before touching it.

NOTE

Additional information on setting up the equipment:

- Programming parameters and control loop behavior are described in the online help of the setup software.
- Kollmorgen can provide training courses for the decentral drive system upon request.

10.2 WorkBench Installation

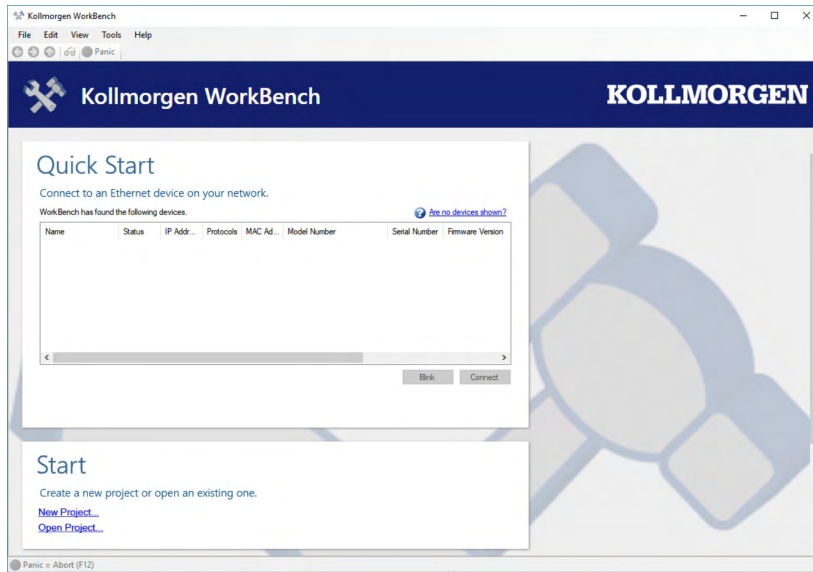

The setup software WorkBench is intended to be used for altering and saving the operating parameters for the decentral drive system. The attached device can be set up with the help of this software, and during this procedure the drive can be controlled directly by the service functions.

You can find the setup software on the accompanying DVD and in the download area of the Kollmorgen website.

Kollmorgen offers training and familiarization courses on request.

NOTE

Only professional personnel who have the relevant expertise (→ # 11) are permitted to carry out online parameter setting for a drive that is running. Sets of data that have been stored on data media are not safe against unintended alteration by other persons. Unexpected move could be the result if you use unchecked data. After loading a set of data you must therefore always check all parameters before enabling the drive.

For most applications, you can use a PC and WorkBench (the drive setup software) to set up the operating conditions and parameters for your drive. The PC is connected to the intelligent power supply by an Ethernet cable (see installation manuals for *AKD-C / MKD-C*). The setup software provides the communication between the PC, the power supply and the AKD-N.

NOTE

With WorkBench every drive that is connected to the same AKD-C/MKD-C as the PC is visible. and controllable

You can select a drive out of the list, alter parameters, and instantly observe the effect on the drive, since there is a continuous (online) connection to the drive. You can also read important actual values from the selected drive, which are displayed on the monitor of the PC (oscilloscope functions).

You can save sets of data on data media (archiving) and load them into other drives or use them for backup. You can also print out the data sets.

10.3 Initial System Test

10.3.1 Unpacking, mounting, and wiring

- Unpack the drive and accessories. Observe the safety instructions in the documentation.
- Mount the drive (→ # 50)ff).
- Connect the AKD-N via the hybrid cables to the AKD-C or MKD-C (→ # 54)ff .
- Connect Motor (→ # 68) and feedback (→ # 71) (single cable or dual cable connection depending on motor and AKD-N version).
- Make sure you have on hand the following information about the drive components:
 - rated mains supply voltage
 - motor type (motor data, if the motor type is not listed in the motor database)
 - feedback unit built into the motor (type, poles/lines/protocol)
 - moment of inertia of the load
- Connect a PC with the installed WorkBench setup software to the power supply connector X18. See installation manuals for *AKD-C / MKD-C* for more information.

10.3.2 Set IP address

The Node address can be set with the WorkBench setup software or via the used fieldbus.

10.3.3 Confirm connections

Switch on 24 VDC logic power for the system (mains supply voltage is not needed for communications).

Confirm that the link LEDs on the AKD-C are both illuminated.

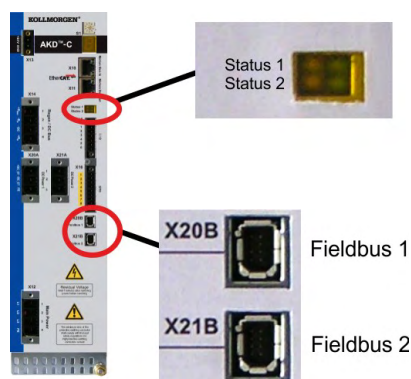

While the PC is connecting, your statusbar will show the following acquiring icon:

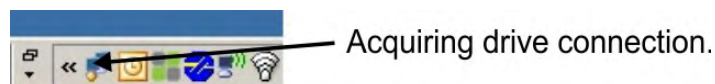

Wait for this icon to change to the limited functionality icon (this process can take up to one minute).

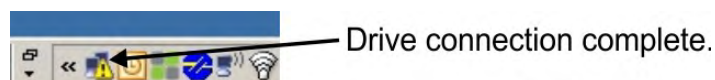

Although Windows displays this limited functionality icon for the drive connection, the PC can communicate fully with the drive. Using WorkBench, you can now configure the drive through this connection.

10.3.4 Install and start WorkBench

WorkBench installs automatically from the DVD included with the drive. WorkBench is also available on the Kollmorgen Web site: www.kollmorgen.com.

Once installation is complete, click the WorkBench icon to start the program. WorkBench will show a list of all the drives that it can find connected to the power supply. Select the drive you wish to configure and then click **Next**.

If multiple drives are detected, a drive can be uniquely identified using one of the following methods:

1. The MAC address of the drive. This address is printed on the sticker on the side of the drive.
2. The name of the drive. The drive name is set using WorkBench. A new drive defaults to "No_Name."
3. Blinking the display. Select a drive and click **Blink** to force the LED of the drive to blink on and off for 20 seconds.

10.3.5 Enable the drive using the setup wizard

Once a connection to the drive has been established, the AKD Overview screen appears. Your drive appears in the navigation area on the left of the screen. Right click on your drive name and select **Setup Wizard** from the drop-down menu. The Setup Wizard guides you through the initial drive configuration, which includes a simple test motion.

After completing the Setup Wizard, your drive should be enabled. If the drive is not enabled, check the following:

1. The hardware enable (HW) for the drive strings must be in the enabled state.
2. The software enable (SW) must be in the enabled state. Activate using the **Enable/Disable** button on the upper toolbar on WorkBench or in the Overview screen.
3. No faults may be present (click the **Clear Fault** button on the upper tool bar to clear any faults).

The status of HW enable, SW enable, and Faults is displayed in the lower toolbar of the WorkBench software. The drive is connected if the lower right corner shows **Online**.

You can now use the Settings View in WorkBench to complete advanced configuration of your drive.

10.4 Fault and Warning Messages

When a fault occurs, the AKD-C/MKD-C fault relay is opened, the output stage is switched off (motor loses all torque), or the load is dynamically braked. If a warning is issued prior to the fault, the warning has the same number as the associated fault. Warnings do not trip the power stage of the drive or fault relay output.

Within a string several drives might show warnings or faults. All actual faults and warnings can be monitored with the WorkBench setup software via the power supply service interface or with the used motion controller software connected via the power supply motion bus interface.

NOTICE

Eliminate errors and faults in compliance with work safety rules. Troubleshooting only by qualified and trained staff.

NOTE

More information about fault messages, remedy and clearing faults can be found in the WorkBench online help.

11 Index

A

Abbreviations	9
AKD Family	27
Ambient conditions	29
Ambient temperature	29

C

Cable and Wire Requirements	31
Conformance	
CE	20
EAC	22
REACH	22
RoHS	22
Safety	20
UL, cUL	21
Connection Diagrams	
DB Variant	62
DF/DS Variants	64
DG/DT Variants	63
Connection Overview	60
Connector Assignments	
DB Variant	60
DF/DS Variants	61
DG/DT Variants	60
Connectors	30

D

Decommission	17
Digital inputs	66
Digital Outputs	67
Disassemble	17
Disposal	18
Document Revisions	81

E

EAC	22
Enclosure protection	29

F

Fault messages	78
Feedback	71

G

General	7
Grounding	56

H

Humidity	
in operation	29
Storage	16

Transport	16
Hybrid Connection	65

I

I/O Connection	65
Initial Drive Test	77
Inputs	
Basic Data	29
Programmable	66
STO	42
Installation	
Electrical	54
Mechanical	50
Installation, Setup, Normal Operation	17

M

Maintenance	17
Marquages UL	21
Motor-holding brake	69
Motor interface	68
Motor overload protection	68
Mounting position	29

N

Nameplate	24
Noise Emission	29

O

Outputs	
Basic Data	29
Programmable	67

P

Package supplied	24
Packaging	16
Part number scheme	25
Pollution level	29
Prohibited Use	
General	14
STO	43

R

REACH	22
Repair	18
Response Time STO	44
RoHS	22

S

Safe Torque Off (STO)	42
Safety Instructions	
General	10
Local STO	45
Setup	75
Setup Software	76

Site altitude	29
Stacking Height	
Storage	16
Transport	16
STO	42
Global STO AKD-C	42
Global STO MKD-C	42
Local STO	42
Response Time	44
Storage	16
Switch-on/switch-off behavior	35
Symbols used	9
T	
Temperature	
in operation	29
Storage	16
Transport	16
Transport	16
U	
UL Markings	21
Use as directed	
General	13
STO	43
V	
Ventilation	29
Vibrations	29
W	
Warnings	78
Wiring	59

12 Record of document revisions

Revision	Remarks
A, 11/2013	First edition
B, 05/2014	STO section updated
C, 12/2014	Patents updated, typos corrected, HR changed acc. to export control
D, 06/2015	STO certified, UL listed, EAC certified, RoHS/REACH statements added
E, 12/2015	Connection diagram DF/DS updated, topology example extended, "Package supplied" extended, motor brake current updated, order code heat conducting film changed, KSM notes removed, STO application examples corrected, input power in kVA, output power in kW, LVD 2014/35/EG, EMCD 2014/30/EG
F, 09/2016	Standard for vibration class corrected, 12A and DG/DT versions added, warning notes updated, Project Guide notes, peak output current updated, UL Markings updated, package supplied updated
G, 03/2017	References to cable connector option A3 removed, tertiary fieldbus cable type updated
H, 10/2017	Global STO note, enclosure/wiring note, product prohibited use: elevator
J, 02/2018	Heat sink 40 mm removed, Trademark list updated, SpeedTec spelling corrected
K, 10/2018	Layout of the warning notes updated, user expertise updated, new readers note cover page, wording AKD-N/IP67 environment note
L, 10/2019	EAC, RoHS, AKM2G cable note
M, 10/2021	X5 thermal sensor usage updated, notes for MKD-C power supply, STO input current corrected, Hardware Revision C, package supplied (Safety Notes), chapter "Approvals" restructured, PFH values updated

About KOLLMORGEN

Kollmorgen is a leading provider of motion systems and components for machine builders. Through world-class knowledge in motion, industry-leading quality and deep expertise in linking and integrating standard and custom products, Kollmorgen delivers breakthrough solutions that are unmatched in performance, reliability and ease-of-use, giving machine builders an irrefutable marketplace advantage.



Join the [Kollmorgen Developer Network](#) for product support. Ask the community questions, search the knowledge base for answers, get downloads, and suggest improvements.

North America

KOLLMORGEN

201 West Rock Road
Radford, VA 24141, USA

Web: www.kollmorgen.com
Mail: support@kollmorgen.com
Tel.: +1 - 540 - 633 - 3545
Fax: +1 - 540 - 639 - 4162

Europe

KOLLMORGEN Europe GmbH

Pempelfurtstr. 1
40880 Ratingen, Germany

Web: www.kollmorgen.com
Mail: technik@kollmorgen.com
Tel.: +49 - 2102 - 9394 - 0
Fax: +49 - 2102 - 9394 - 3155

South America

KOLLMORGEN

Avenida João Paulo Ablas, 2970
Jardim da Glória, Cotia – SP
CEP 06711-250, Brazil

Web: www.kollmorgen.com
Mail: contato@kollmorgen.com
Tel.: +55 11 4615-6300

China and SEA

KOLLMORGEN

Room 302, Building 5, Lihpao Plaza,
88 Shenbin Road, Minhang District,
Shanghai, China.

Web: www.kollmorgen.cn
Mail: sales.china@kollmorgen.com
Tel.: +86 - 400 668 2802
Fax: +86 - 21 6248 5367