



## Record of Document Revisions

Edition	Comments
...	Table with lifecycle information of this document see "Record of Document Revisions" (→ p. 59)
08/2014	Brake resistor AKD-x01206 changed, length definitions for decentral hybrid cables updated
12/2014	S640/670 added, AKD-x04807 accessories added
09/2015	Motor cables for AKD-x04807 added, mating connector X5-JUMP for AKD-N new, cabinet connector coupling for decentral drive system removed, notes for slip rings and IP67 grommets, revision history restructured, CFD5A1 cable added. Accessories Manual splitted to AKD and Sxyz versions. First AKD-only revision.

**Technical changes which improve the performance of the device may be made without prior notice!**

Printed in the United States of America

This document is the intellectual property of Kollmorgen. All rights reserved. No part of this work may be reproduced in any form (by photocopying, microfilm or any other method) or stored, processed, copied or distributed by electronic means without the written permission of Kollmorgen.

# 1 Table of Contents

---

<b>1</b>	<b>Table of Contents</b>	<b>3</b>
<b>2</b>	<b>General</b>	<b>7</b>
2.1	About this manual	7
2.2	Hints for the online edition (PDF format)	7
2.3	Safety Notes	7
2.3.1	Symbols Used	7
2.3.2	You should pay attention to this	8
<b>3</b>	<b>Digital Drive Systems</b>	<b>9</b>
3.1	Drive System with AKD-x00306...02406	9
3.2	Drive System with AKD-x00307...02407	10
3.3	Drive System with AKD-x04807	11
3.4	Decentralized Drive System with AKD-C and AKD-N	12
<b>4</b>	<b>Mechanical Accessories</b>	<b>13</b>
4.1	Mounting Kit for AKMH Motors	13
4.2	Suspension Unit for AKM motors	13
4.3	Fan Kit for AKM7 motors	14
4.4	Mechanical accessories for AKD-N and AKD-C	15
4.4.1	Heat Sink for AKD-N	15
4.4.2	Mounting clamps for AKD-N	15
4.4.3	Sealing plugs for AKD-N connectors	16
4.4.4	Jump-X5 connector for AKD-N-DS/DF with single line connection	16
4.4.5	Connector Kit for AKD-C	16
4.4.6	Cabinet grommets	16
4.4.7	Slip rings	16
4.5	Shield clamps	17
<b>5</b>	<b>Mains chokes</b>	<b>18</b>
5.1	General	18
5.2	Important notes	18
5.3	Type assignment and order codes	18
5.4	Mains choke 3L	19
<b>6</b>	<b>Mains filters</b>	<b>20</b>
6.1	General	20
6.2	Important notes	20
6.3	Type assignment and order codes	20
6.4	Mains filters 1NF-10...12	21
6.5	Mains filters 1NF-20B, 1NF-25	22
6.6	Mains filters 3NF-07...30	23
<b>7</b>	<b>Brake resistors</b>	<b>24</b>
7.1	General	24
7.2	Important notes	24
7.3	Type assignment and order codes	25
7.4	External brake resistor BAFF(U)	26

7.5	External brake resistor BAR(U)	27
7.6	External brake resistor BAS(U)	28
<b>8</b>	<b>Capacitor Modules</b>	<b>29</b>
8.1	General	29
8.2	Important notes	29
8.3	Type assignment and order codes	30
8.4	Example installation	30
8.5	KCM Module	31
<b>9</b>	<b>Motor chokes</b>	<b>32</b>
9.1	General	32
9.2	Important notes	33
9.3	Type assignment and order codes	33
9.4	Motor choke 3YLN-xx	34
<b>10</b>	<b>Cables</b>	<b>35</b>
10.1	Technical data for cables	35
10.2	Tools	35
10.3	PC connection	36
10.4	Power Voltage Supply, external brake resistor, DC bus link	36
10.4.1	Recommended cable type	36
10.4.2	Mating connector (part of delivery)	36
10.4.3	Mating connector (optional)	37
10.5	24V auxiliary voltage supply	37
10.5.1	Mating connector (part of delivery)	37
10.5.2	Recommended cable type	37
10.6	Digital/analog Inputs/Outputs	38
10.6.1	Digital In/Outputs for AKD-C	38
10.6.2	Digital In/Outputs for AKD-N	38
10.6.3	Digital/analog I/O for AKD-B/P/T/M	39
10.7	Encoder Emulation, Stepper motor control, Master-Slave	40
10.7.1	Mating connector, cable type	40
10.7.2	Connection	40
10.8	Ethernet cable	40
10.9	CAN bus cable	41
10.10	Decentral Drive System Hybrid Cables	42
10.10.1	AKD-C to AKD-N in the decentralized drive system	42
10.10.2	AKD-N to AKD-N in the decentralized drive system	42
10.11	Motor Hybrid Cables	43
10.11.1	AKD to AKM1 Motor (i-tec connector)	43
10.11.2	AKD to AKM2-6 (M23 connector)	44
10.12	Motor Power Cables	46
10.12.1	General	46
10.12.2	Motor cables, configured	46
10.12.2.1	Order codes motor cables for AKD-B/P/T/M	47
10.12.2.2	Order codes motor cables for AKD-N	50
10.12.3	Preparing motor cables (motor end)	51
10.12.3.1	Motor series AKM1...8 with M23 or M40 connector	51

---

10.12.3.2 Motor series AKM8 with terminal box .....	51
10.12.4 Preparing motor cables (servo amplifier end), AKD-B/P/T/M .....	53
10.12.4.1 Preparing cables for AKD-x00306/x00606 .....	53
10.12.4.2 Preparing cables for AKD-x01206/x02406/x00307 to x02407 .....	54
10.12.4.3 Preparing cables for AKD-x04807 .....	54
<b>10.13 Motor Feedback Cables .....</b>	<b>55</b>
10.13.1 Resolver cables .....	55
10.13.2 SFD cables .....	56
10.13.3 Encoder cables .....	57
10.13.4 ComCoder cables .....	58
<b>11 Record of Document Revisions .....</b>	<b>59</b>

This page intentionally left blank.

## 2 General

### 2.1 About this manual

This manual describes accessories for Kollmorgen AKD amplifiers. It contains essential technical data. The manual is only valid in conjunction with the instructions manual for the servo amplifier and servo motor you are using in your application.

You will find copies of the instructions manual for Kollmorgen servo amplifiers and servo motors on the CD ROM included in the scope of supply and on our Internet site. The documents are available in Acrobat Reader format in multiple languages (system requirements: WINDOWS, Internet browser, Acrobat Reader).

More detail information can be found in the "European Product WIKI" available at [www.wiki-kollmorgen.eu](http://www.wiki-kollmorgen.eu).

### 2.2 Hints for the online edition (PDF format)

**Bookmark:** Table of contents and index are active bookmarks.

**Table of contents and index in the text:** The lines are active cross references. Click on the desired line and the appropriate page is indicated.

**Page/chapter numbers in the text:** Page/chapter numbers with cross references are active. Click at the page/chapter number to reach the indicated target.

### 2.3 Safety Notes

This section helps you to recognize and avoid dangers to people and objects.

#### 2.3.1 Symbols Used

Symbol	Indication
 <b>DANGER</b>	Indicates a hazardous situation which, if not avoided, will result in death or serious injury.
 <b>WARNING</b>	Indicates a hazardous situation which, if not avoided, could result in death or serious injury.
 <b>CAUTION</b>	Indicates a hazardous situation which, if not avoided, could result in minor or moderate injury.
<b>NOTICE</b>	Indicates situations which, if not avoided, could result in property damage.
<b>NOTE</b>	This symbol indicates important notes.

### 2.3.2 You should pay attention to this

#### Read the documentation!

Read the available documentation before installation and commissioning. Improper handling of the devices can cause harm to people or damage to property. The operator must therefore ensure that all persons entrusted to work on the devices have read and understood the manual and that the safety notices in this manual are observed.

Always observe the whole drive system built with servo amplifier, cables, motor, accessories (filters, chokes, etc.). This means, that all documentation which exist for the components, must be available, must be read and must be understood.

#### Pay attention to the technical data!

Adhere to the technical data and the specifications on connection conditions (rating plate and documentation). If permissible voltage values or current values are exceeded, the devices can be damaged, e.g. through overheating.

#### Specialist staff required!

Only properly qualified personnel are permitted to perform such tasks as transport, assembly, setup and maintenance. Qualified specialist staff are persons who are familiar with the transport, installation, assembly, commissioning and operation of power electronics and who bring their relevant minimum qualifications to bear on their duties. The qualified personnel must know and observe IEC 60364 / IEC 60664 and national accident prevention regulations.

Additional requirements on specialist staff may also result from the risk assessment.

#### Hot surface!



Some devices can reach temperatures of up to 250°C during operation. Touching them can result in burns. Observe the permissible mounting position and ensure that a sufficient distance is maintained from neighboring assemblies.

#### Earthing!



It is vital that you ensure that the device housing is safely earthed to the PE (protective earth) busbar in the switch cabinet. Without low-resistance earthing no personal protection can be guaranteed and there is a risk of death from electric shock.

#### High voltages!



Keep the switching cabinet closed when the equipment is in operation. Not having optical displays does not guarantee an absence of voltage. Power connections may carry voltage even if the motor is not turning.

Do not unplug any connectors during operation. There is a risk of death or severe injury from touching exposed contacts. Power connections may be live even when the motor is not rotating. This can cause flashovers with resulting injuries to persons and damage to the contacts.

DC Bus link connections can carry dangerous voltage levels over an hour after the line voltage has been switched off (self-discharge time). Danger of death from electric shock.

Before commencing work on the modules' power terminals, check the voltage at the connection terminals is de-energized to ground and to each other.

### 3 Digital Drive Systems

The systems shown are simply a possible scenario for setting up a digital drive system with relevant servo amplifier components.

#### 3.1 Drive System with AKD-x00306...02406

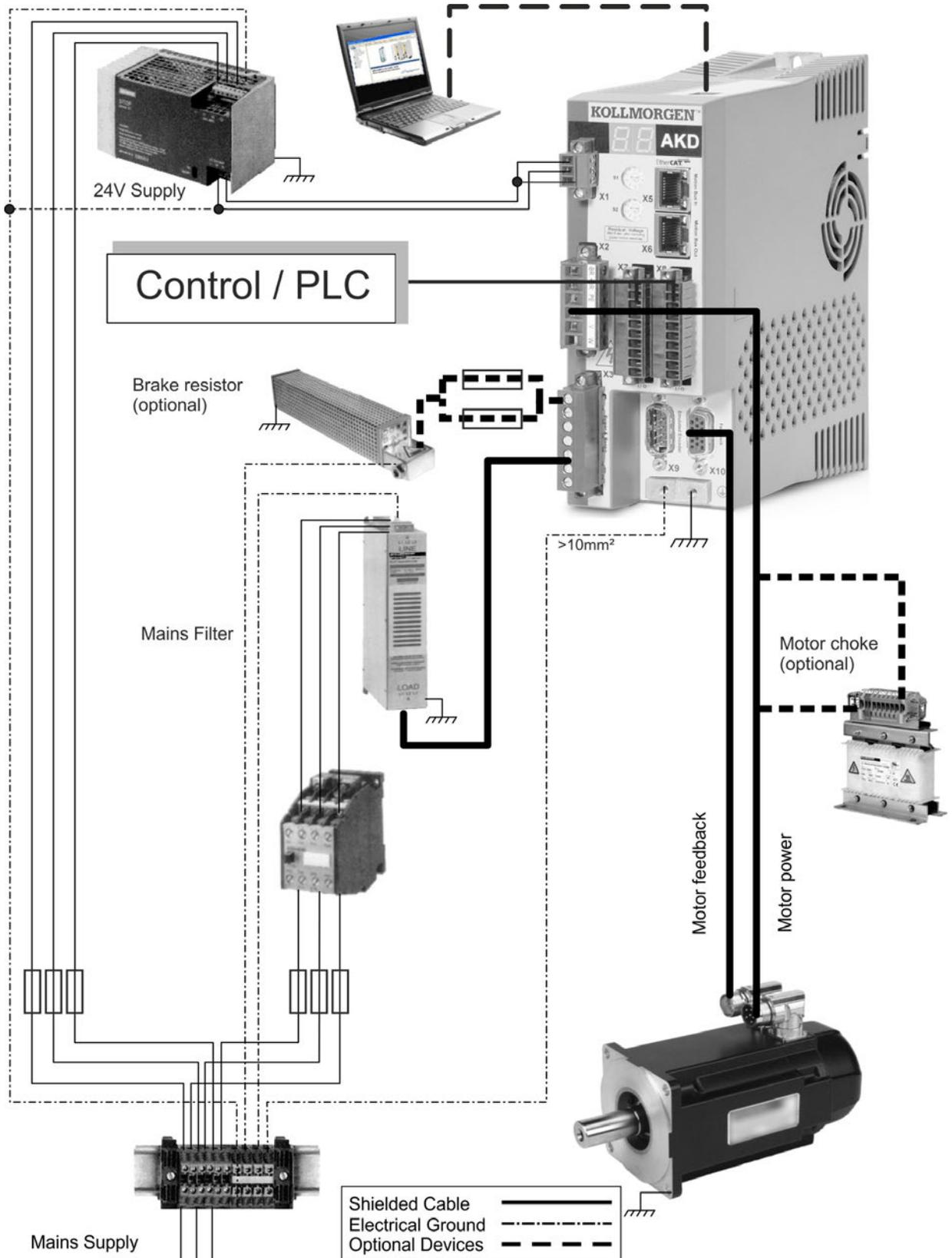

### 3.2 Drive System with AKD-x00307...02407

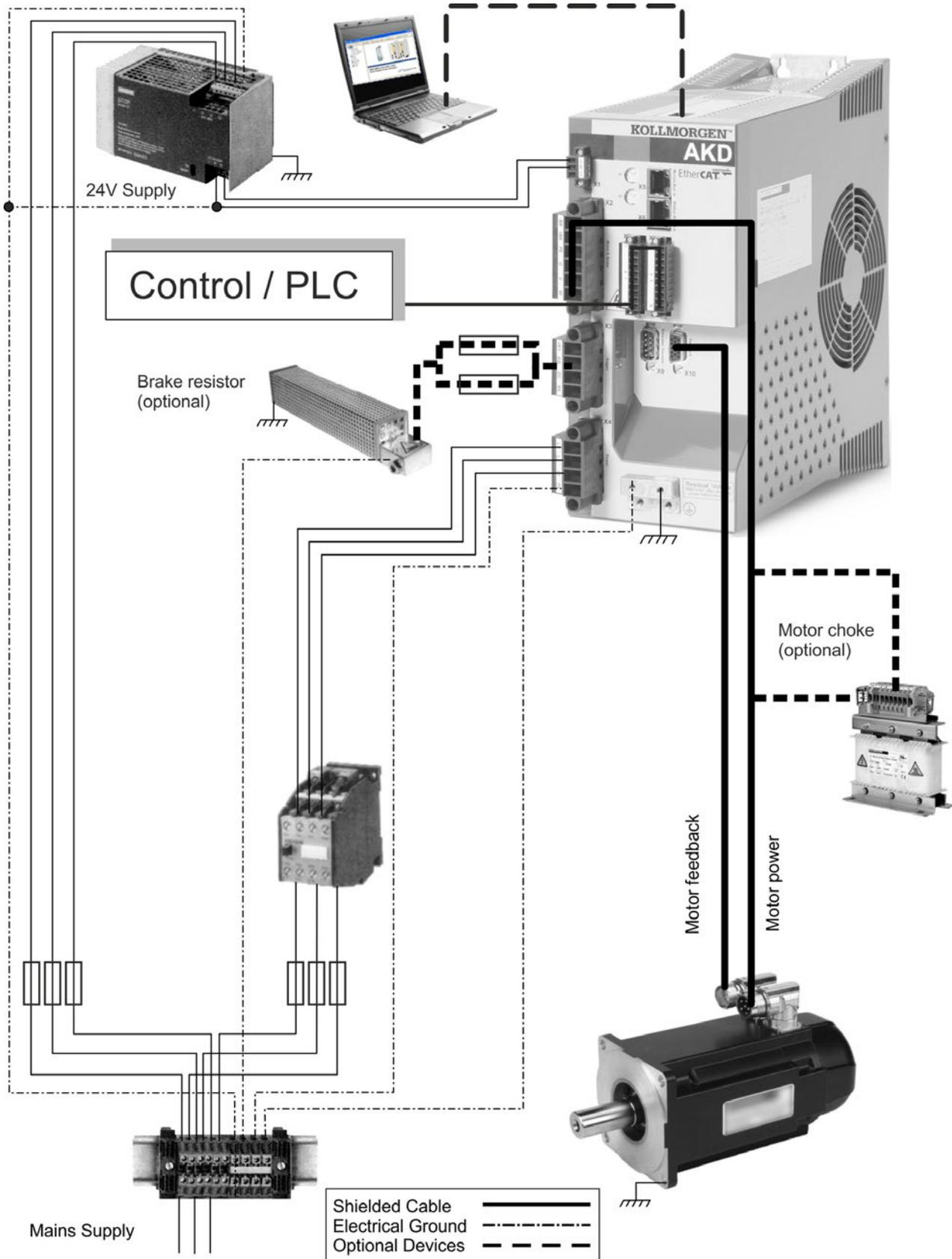

### 3.3 Drive System with AKD-x04807

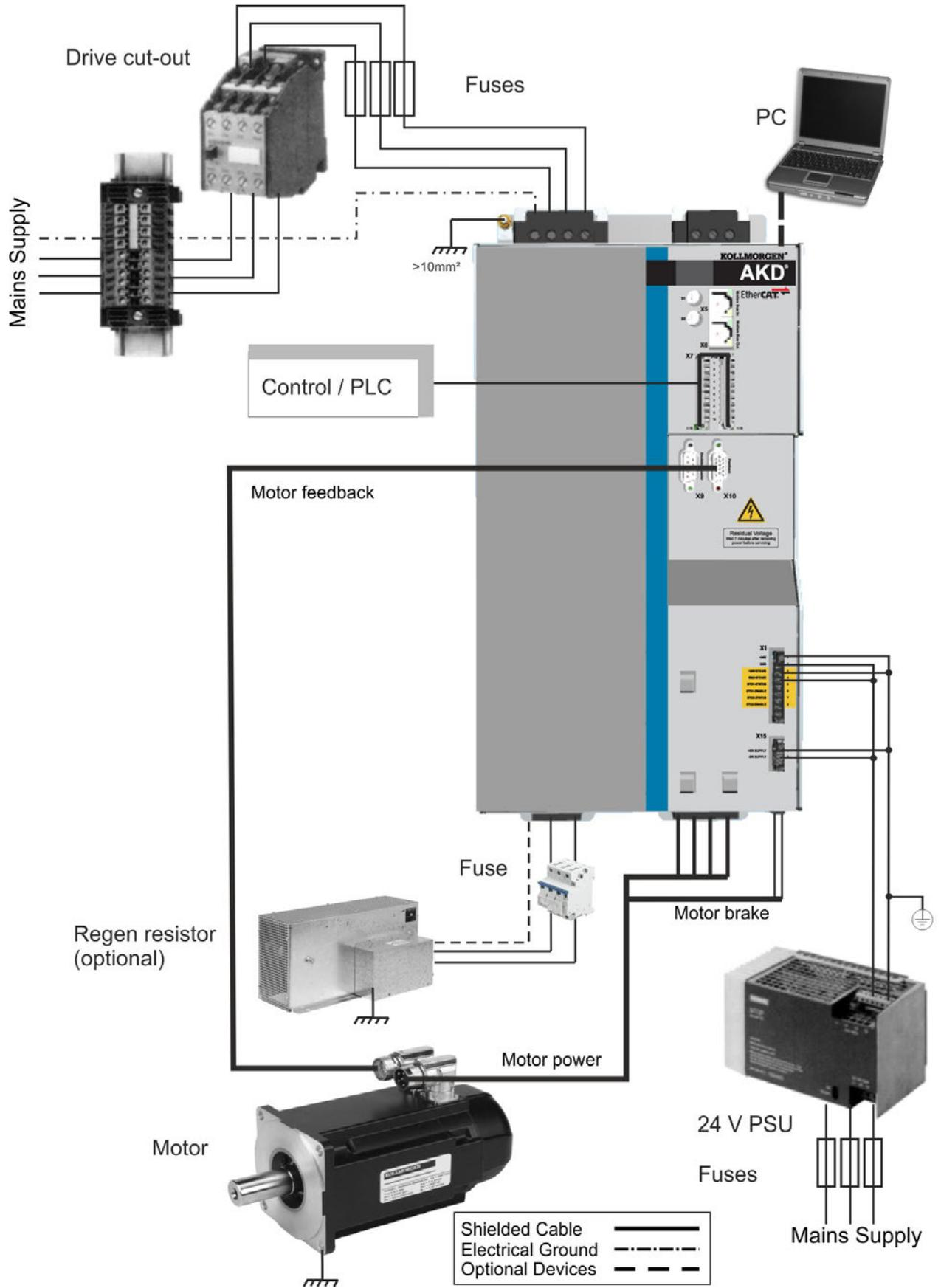

### 3.4 Decentralized Drive System with AKD-C and AKD-N

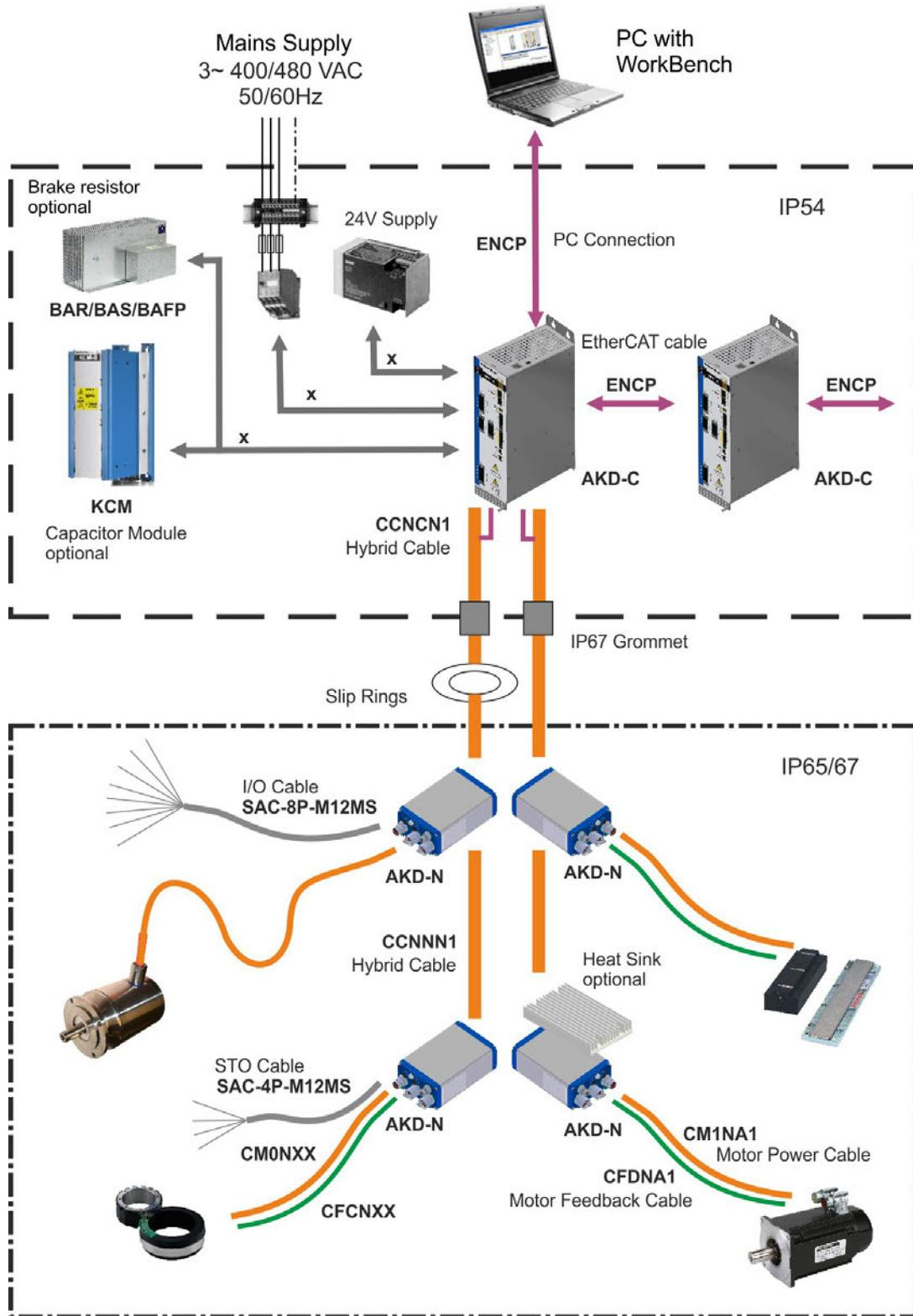

All components inside the borders are supplied by Kollmorgen with the exception of cables signed with "x". These cables are not supplied by Kollmorgen, you should use cables or wires according to EN 60204.

## 4 Mechanical Accessories

### 4.1 Mounting Kit for AKMH Motors

IEC mounting kits with 1 shaft center screw and 4 flange screws. Hygienic mounting is possible only with these screws.

Description	Order Code
Mounting Hardware AKMH2, Ax flange / Cx front mounting	MTG-KIT-AKMH2-IEC
Mounting Hardware AKMH3, Ax flange / Cx front mounting	MTG-KIT-AKMH3-IEC
Mounting Hardware AKMH4, Ax flange / Cx front mounting	MTG-KIT-AKMH4-IEC
Mounting Hardware AKMH5, Ax flange / Cx front mounting	MTG-KIT-AKMH5-IEC
Mounting Hardware AKMH6, Ax flange / Cx front mounting	MTG-KIT-AKMH6-IEC

NEMA mounting kits are described in the US selection guide, available from the Kollmorgen website [www.kollmorgen.com](http://www.kollmorgen.com)).

### 4.2 Suspension Unit for AKM motors



#### DANGER

Suspended load. Risk of death if load falls. Never step under the load, while the motor is raised!

#### NOTICE

You must read the instructions manual for the suspension unit ZPMZ 120/292. Observe the "safety instructions" and "use as directed" hints before starting transportation work.

The Suspension Unit ZPMZ 120/292 is designed for suspended handling exclusively of motors (i.e., without attached units such as gearboxes, clutches, etc.) with a maximum weight of 120 kg and maximum nominal span of the extreme suspension hooks of 292 mm.

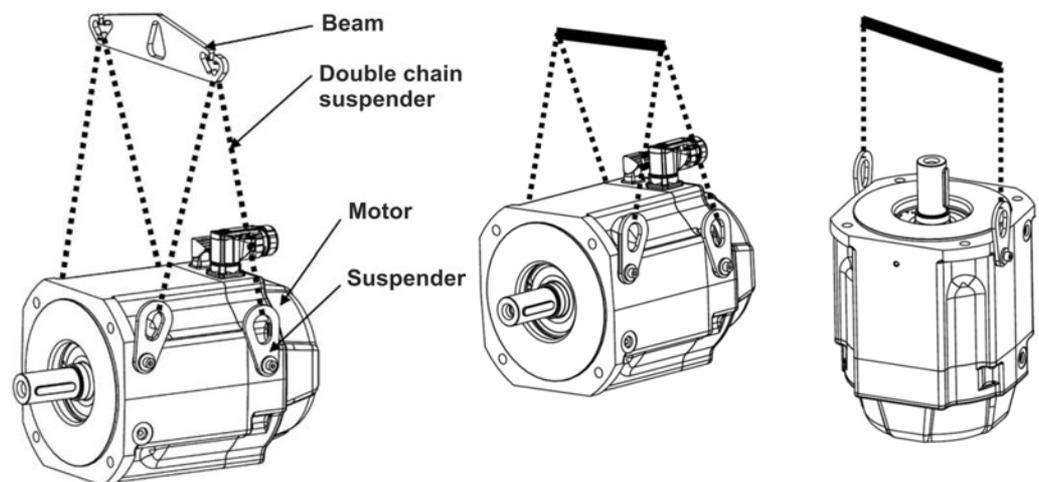

The suspended unit consists of a Beam, suspended off the crane hook and two double-run chain suspenders. The motor may be borne on two or four runs of the chain suspender.

The suspenders (number depends on the motor type) are delivered with the motor.

Technical Data				
Lifting capacity	120 kg		Weight	0,83 kg
Nominal span	292 mm		Number of cycles a year	20.000
Lug width	44,7 mm		Average load	60 %
Lug height	51 mm		Order code	FA00092

### 4.3 Fan Kit for AKM7 motors

**NOTICE**

Observe the mounting instructions delivered with the fan kit. The fan housing can be mounted either with both the supplied brackets and spacers or with the brackets only. The choice of mounting method depends on the application. If strong vibrations are expected, you should use both brackets and spacers. Motors with integrated brakes require the long spacers.

Mounting the fan kit enlarges the motor by approximately 65 mm. The detailed final dimensions of AKM7 motors with mounted fan kit can be found in the instructions manual of the AKM motor series. Ventilation of AKM7 motors allow increased current of the motors. This higher current usually requires larger wiring cross section compared to not ventilated motors. The necessary data for current and wiring cross section can be found in the technical data section of the AKM instructions manual.

Technical Data	
Supply voltage	24 VDC
Supply current	270 mA
Electrical power	6.5 W
Surface	Coated with polyester powder coating in matt black, not resistant against solvents
Protection class	IP 20
Connection	Cable gland 10 mm, cable diameter 4 mm to 6 mm, recommended cable 3x0.75 mm <sup>2</sup> (not part of delivery)
Terminals	0.33 mm <sup>2</sup> to 4 mm <sup>2</sup>
Weight	2.52 kg
Order code	AKM7-FAN

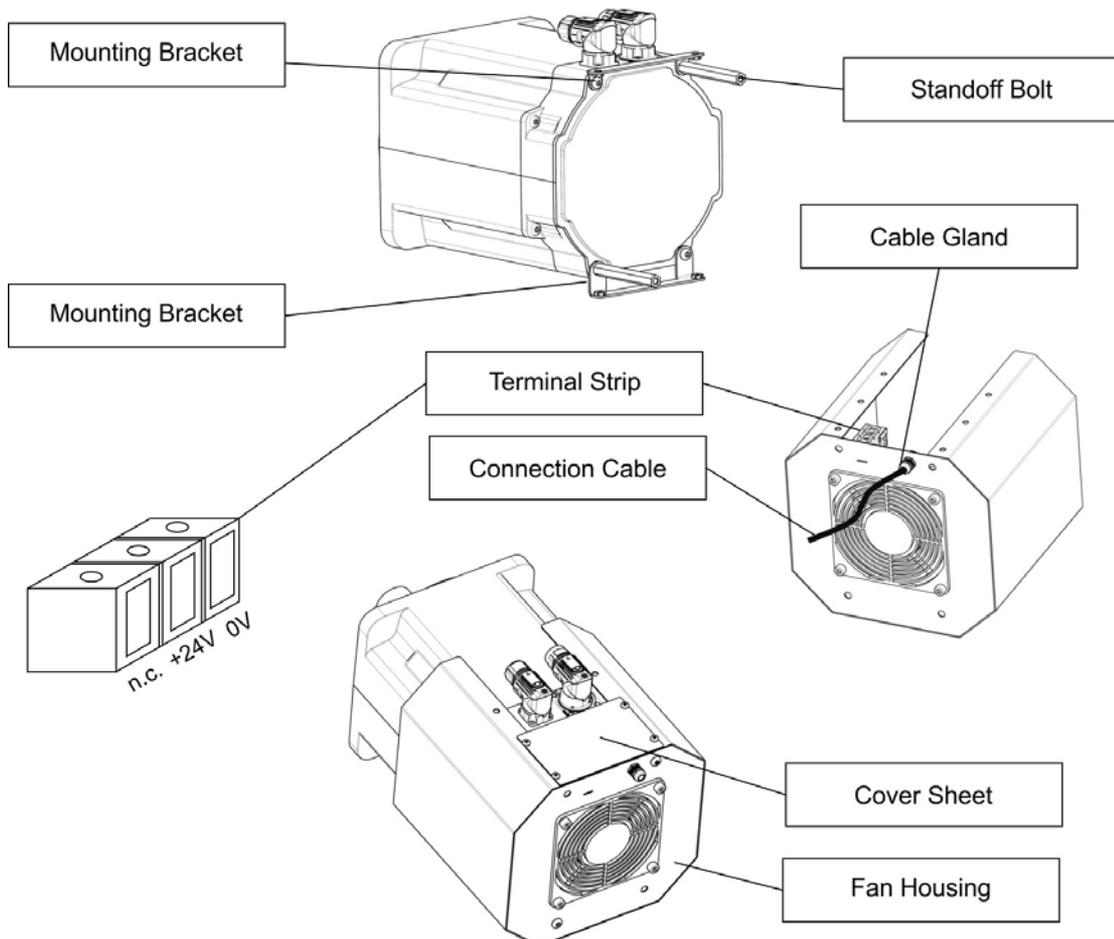

## 4.4 Mechanical accessories for AKD-N and AKD-C

### NOTICE

You must read the AKD-N/AKD-C installation manuals. Observe the safety instructions given there before commencing mounting/installation work.

### 4.4.1 Heat Sink for AKD-N

When mounting AKD-N to the machinery, temperature management is important to ensure maximum performance of the drive system. In case of medium or bad cooling situation (as described in the AKD-N Installation Manual), you can mount a heat sink to the AKD-N.

Heat flow is optimized by a heat conducting film, which must be placed between heat sink and AKD-N.

Mounting holes in the heat sink and winding holes in the AKD-N are prepared for M4x16 hexagon socket screws to ISO 4762. Use a 3 mm T-handle Allen key for mounting.

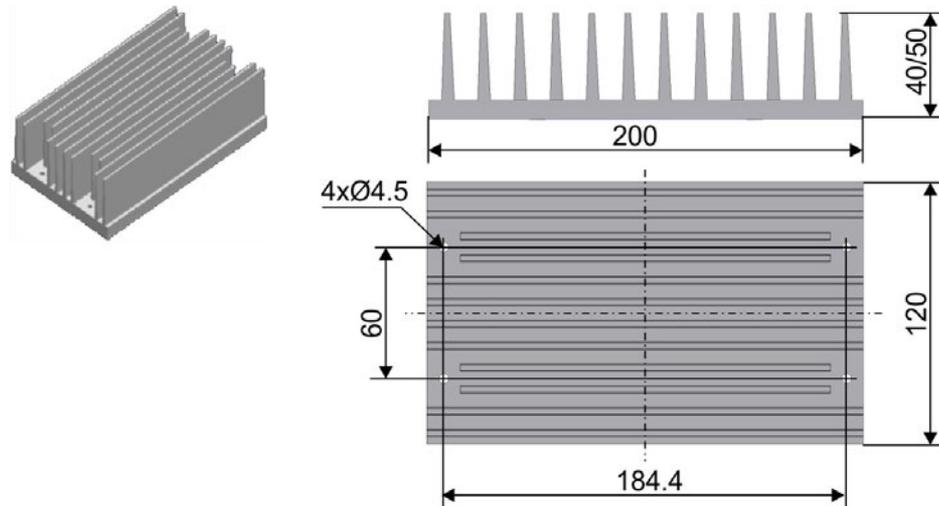

#### Order Codes

Article	Order codes
Heat sink Kit 40 mm with Heat conducting film and 4 screws M4x16	AKD-N 3,6 HEATSINK KIT 40MM
Heat sink Kit 50 mm with Heat conducting film and 4 screws M4x16	AKD-N 3,6 HEATSINK KIT 50MM
Heat conducting film	849-373000-04

### 4.4.2 Mounting clamps for AKD-N

The AKD-N servo amplifier is mounted to the machine with special mounting clamps. The delivery package contains 4 clamps. In case of lost or damaged clamps, you can order a set of four clamps.

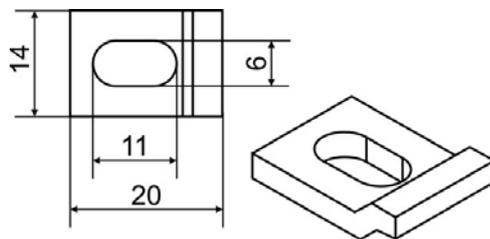

#### Order Codes

Article	Order codes
AKD-N Mounting Clamps Set, 4 clamps	AKD-N-M/C-Set

#### 4.4.3 Sealing plugs for AKD-N connectors

The sealing plugs in the delivery package are screwed to unused AKD-N connectors to ensure the IP class for the machine environment. In case of lost plugs, you can order a set with 3 different plug sizes.



##### Order Code

Article	Order Codes
AKD-N Sealing Plug Set, 4xM12, 2xM23, 2xM17	AKD-N-S/P-Set

#### 4.4.4 Jump-X5 connector for AKD-N-DS/DF with single line connection

For sufficient voltage supply of the digital feedback systems Hiperface DSL or SFD3 connected to AKD-N-DS/DF connector X4, a dongle must be plugged to X5.

##### Order Code

Article	Order Codes
AKD-N X5 sealed mating connector with jumper 4-5	AKD-N-JUMP-X5

#### 4.4.5 Connector Kit for AKD-C

Mating connectors X12, X13, X14, X15, and X16 are part of delivery. If a mating connector is lost or damaged, you can order the AKD-C Connector Kit.

##### Order Code

Article	Order Codes
AKD-N Connector Kit, included mating connectors X12, X13, X14, X15, and X16	AKD-C-CONKIT

#### 4.4.6 Cabinet grommets

The hybrid cable between AKD-C and the first AKD-N leads through the cabinet wall. To ensure IP67 protection class, Kollmorgen recommends cable entry system KDL/S combined with cable entry grommet KDT/S manufactured by Murrplastik Systemtechnik GmbH. Please contact:

##### **Murrplastik Systemtechnik GmbH**

Fabrikstraße 10, D-71570 Oppenweiler, Germany

Phone: +49 (0)7191 482-0, Website: [www.murrplastik.de](http://www.murrplastik.de), E-Mail: [info@murrplastik.de](mailto:info@murrplastik.de)

#### 4.4.7 Slip rings

If AKD-N must be mounted on a rotary table, it is necessary to use slip ring assemblies for energy and data transfer between AKD-C in the cabinet and AKD-N on the rotary table. Kollmorgen cooperates with company STEMMANN-TECHNIK for user specific slip ring assembly solutions. Please contact:

##### **STEMMANN-TECHNIK GmbH**

Niedersachsenstraße 2, D-48465 Schüttorf, Germany

Phone: +49 (0)592381-0, Website: [www.stemmann.com](http://www.stemmann.com), E-Mail: [sales@stemmann.de](mailto:sales@stemmann.de)

## 4.5 Shield clamps

**NOTICE**

You must read the instructions manuals for the servo amplifier/servo motor you are using in your application. Observe the safety instructions they contain before commencing mounting/installation work.



These servo amplifiers feature slots on the front panel for the connection of additional shield clamps.

Article	Tension range	Order Codes
SK14	6-13mm	DE-108248

## 5 Mains chokes

### NOTICE

You must read the instructions manuals for the servo amplifier and servo motor you are using in your application. Observe the safety instructions given there.

### 5.1 General

In special cases, if mains voltage is more than 3% asymmetrical, then the AKD-48A must be used with a mains choke. In unfavorable combination of mains impedance and DC bus capacitance the unloaded DC bus may reach voltage up to 800V without choke. For EMC reasons the chokes should be mounted isolated to the cabinet. Single conductors can be used for wiring, shielded cables are not required. More information can be found on our "European Product WIKI" "[Mains Choke](#)". Purpose of mains choke:

- Prevents impermissible loading of semiconductors in the event of rapid current rise during commutation.
- Prevents voltage dips in the mains voltage caused by commutation.
- Reduces current ripple in the DC link, thereby increasing the service life of the DC link capacitors.

### 5.2 Important notes



#### DANGER

Power terminals are capable of conducting hazardous voltage up to 10 minutes after the mains voltage has been disconnected. Risk of electric shock. Before starting work on power terminals, check that the phase-to-earth and phase-to-phase voltages have de-energised.

### NOTICE

Due to the high earth leakage currents induced by the system, you should observe the requirements of EN 61800-5-1 (e.g. fixed installation,  $\geq 10 \text{ mm}^2$  or double protective earth) when carrying out mounting and installation work. You must read the instructions manual for the servo amplifier/servo motor you are using in your application and observe the safety instructions they contain before commencing mounting/installation work.

Mounting: 50mm free space required above and below the device.

Connection diagram: see servo amplifier instructions manual.

### 5.3 Type assignment and order codes

Servo amplifier	Mains choke
AKD-x04807 (with asymmetrical mains >3% only)	2% uk
AKD other types	not required

#### Order Codes

Article	uk	Order codes
Mains choke 3L0,24-50-2 (0.24mH, 50A)	2%	DE-201476
Mains choke 3L0,2-75-2 (0.20mH, 75A)	2%	DE-201477

### 5.4 Mains choke 3L

**NOTICE**

A number of servo amplifiers can be connected to one and the same mains choke; the rated current of the mains choke must be greater than or at least equal to the total current of the connected servo amplifiers.

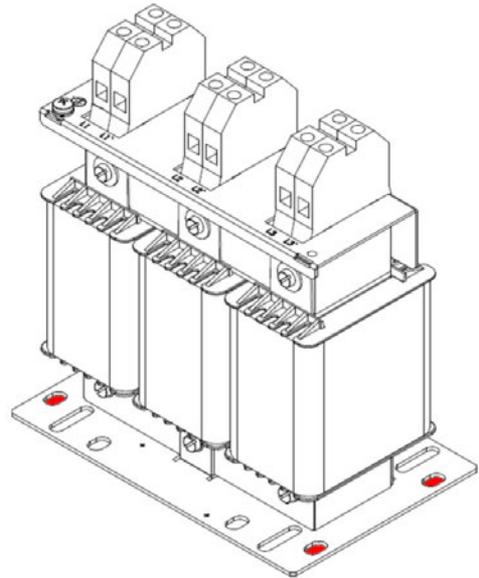
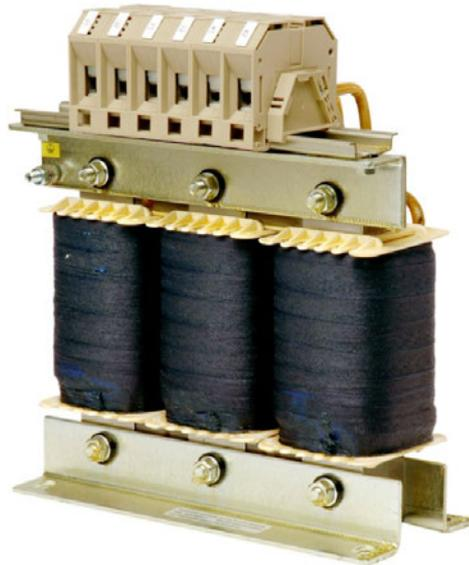
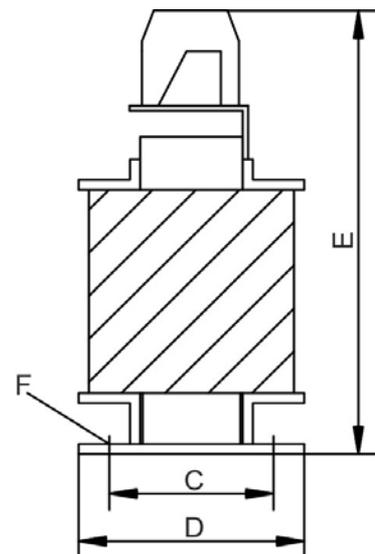
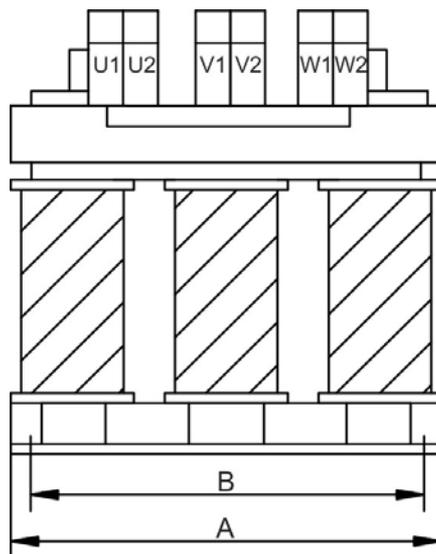

Photo: all models are similar



**Technical Data**

Type	Inductivity [mH]	Nominal Current [A]	uk [%]	A [mm]	B [mm]	C [mm]	D [mm]	E [mm]	F [mm]	Terminals [mm <sup>2</sup> ]	Weight [kg]
3L 0,24-50-2	0.24	50	2	152.5	114.3	88.9	114.3	163	6.5	10	5.9
3L 0,2-75-2	0.20	75	2	185	170	77	122	220	8x12	35	9.9

## 6 Mains filters

### 6.1 General

AKD-x00306 to AKD-x02406 servo amplifiers require an external mains filter. All other servo amplifiers feature built-in mains filters (see the relevant instructions manual). The filtering effect of the mains filters can only be assured if the permissible throughput rating of the mains filters is not exceeded even on peak loading of the servo amplifiers with  $I_{peak}$ .

The max. available throughput rating of the mains filter must be higher than the max. power consumption of the servo amplifiers and higher than the maximum power consumption of the motors. More information can be found on our "European Product WIKI" "[Mains Filter](#)".

### 6.2 Important notes



#### DANGER

Power terminals are capable of conducting hazardous voltage up to 10 minutes after the mains voltage has been disconnected. Risk of electric shock. Before starting work on power terminals, check that the phase-to-earth and phase-to-phase voltages have de-energized.

#### NOTICE

Due to the high earth leakage currents induced by the system, you should observe the requirements of EN 61800-5-1 (e.g. fixed installation,  $\geq 10 \text{ mm}^2$  or double protective earth) when carrying out mounting and installation work. You must read the instructions manuals for the used components and observe the safety instructions they contain before commencing mounting/installation work. See servo amplifier instructions manual for connection diagrams.

### 6.3 Type assignment and order codes

Servo amplifier	Mains filter
AKD-x00307...04807 (240 to 480V)	not required
AKD-B/P/T/M 00306...02406 (120 to 240V)	1NF, 3NF

#### Order Codes

Article	Order code	Remarks
Mains filter 1NF-10 (230 VAC, 10A)	DE-201565	1~, 230V AC, CE*, UL
Mains filter 1NF-12 (230 VAC, 12A)	DE-201566	1~, 230V AC, CE*, UL
Mains filter 1NF-20B (125V/230 VAC, 20A)	DE-201865	1~, IEC 230V AC, UL 125 V AC, CE*
Mains filter 1NF-25 (230 VAC, 25A)	DE-201568	1~, 230V AC, CE*, UL
Mains filter 3NF-07 (480 VAC, 07A)	DE-201569	3~, 480V AC, CE*, UL
Mains filter 3NF-16 (480 VAC, 16A)	DE-201570	3~, 480V AC, CE*, UL
Mains filter 3NF-30 (480 VAC, 30A)	DE-201571	3~, 480V AC, CE*, UL

\* No EC directive matches mains filters actually. You can use the filters in Europe, they are manufactured according to harmonized standards concerning creeping and voltage distances.

### 6.4 Mains filters 1NF-10...12

Observe the safety instructions → p. 20.  
**For single-phase operation only.**

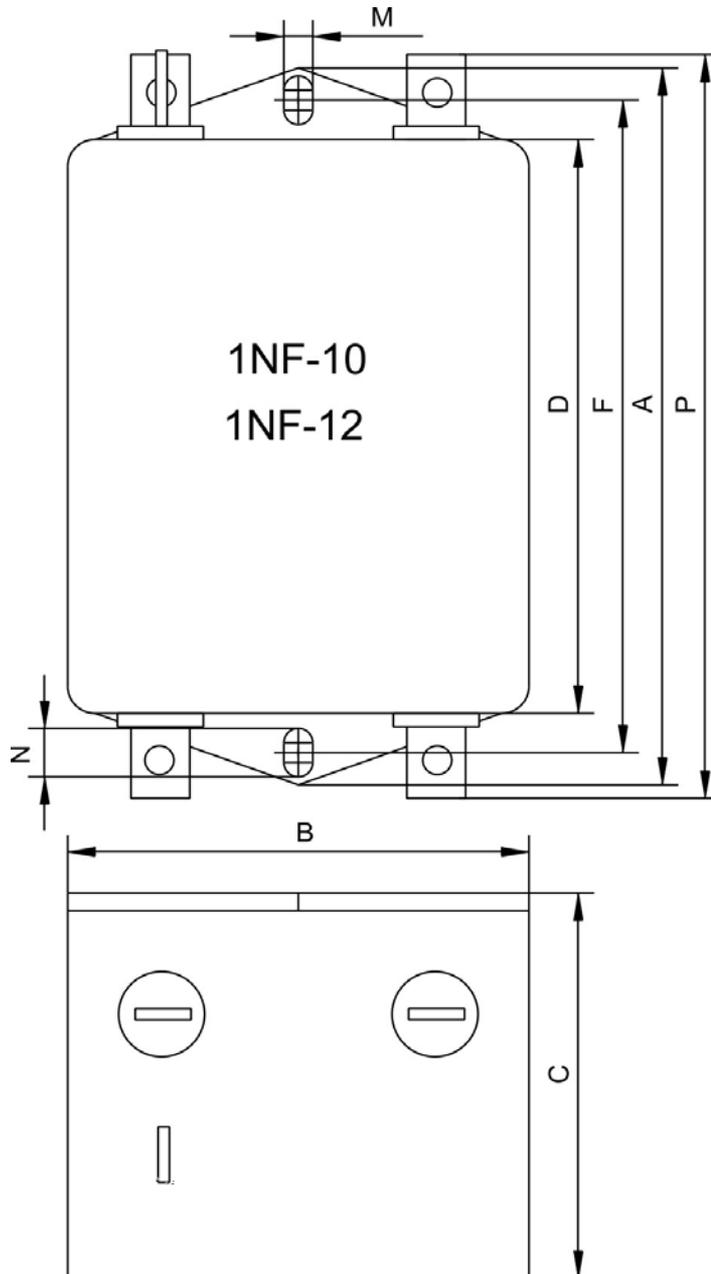

#### Technical Data

Type	Nominal Current [A]*	Nominal Voltage [V]	A [mm]	B [mm]	C [mm]	D [mm]	F [mm]	M [mm]	N [mm]	P [mm]	Weight [kg]	Connection
1NF-10	10	230	85	49	40.3	54	75	5.3	6.3	87	0.29	Fast-on
1NF-12	12	230	156	57.5	45.4	130.5	143	5.3	6	156	0.73	Fast-on

\* at 40°C environment temperature

### 6.5 Mains filters 1NF-20B, 1NF-25



Observe the safety instructions → p. 20.  
**For single-phase operation only.**

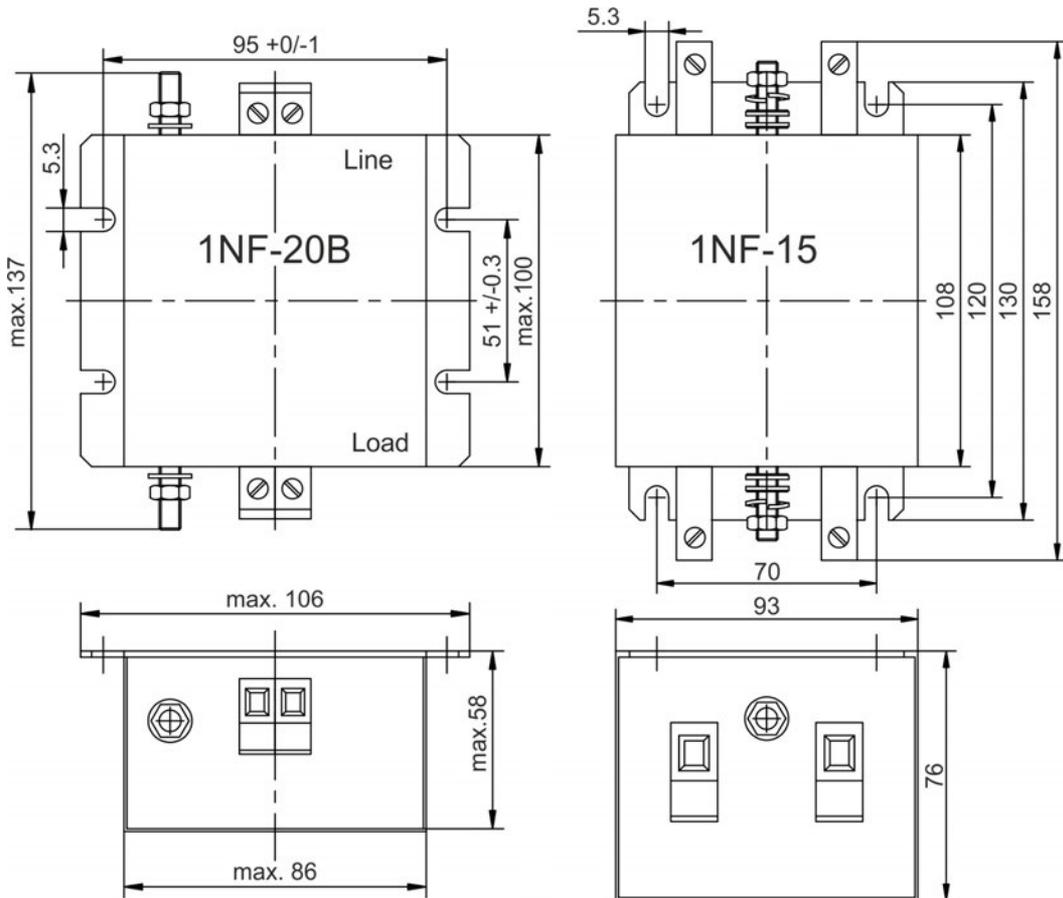

#### Technical Data

Type	Nominal Current [A]*	Nominal Voltage		Weight [kg]	Connection Phase Terminals	Connection PE
		IEC	UL/CSA			
1NF-20B	20	230V	125V	0.93	Wires up to 4mm <sup>2</sup> Torque 0.6 to 0.8 Nm	Bolt M 6 Torque 3.5 to 4 Nm
1NF-25	25	230V	230V	0.7	Wires up to 10mm <sup>2</sup> Torque 1.5 to 1.8 Nm	

\* at 50°C environment temperature

### 6.6 Mains filters 3NF-07...30

Observe the safety instructions → p. 20.

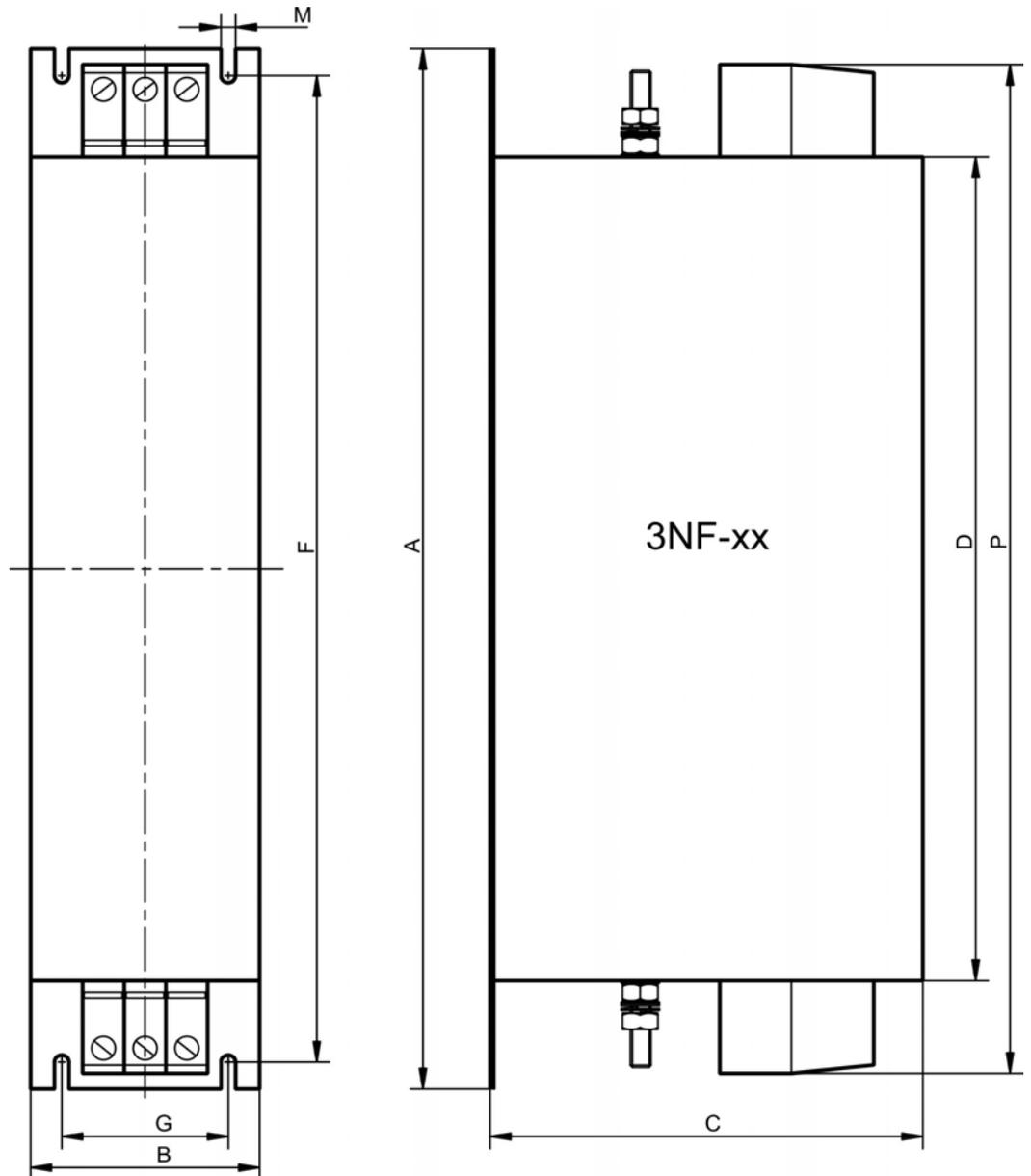

#### Technical Data

Type	Nom. Current*	A [mm]	B [mm]	C [mm]	D [mm]	F [mm]	G [mm]	M [mm]	P [mm]	Weight [kg]	Terminals	PE Bolt
3NF-07	7 A	190	40	70	160	180	20	4.5	180	0.5	4mm <sup>2</sup> ,	M5, 2.2Nm
3NF-16	16 A	250	45	70	220	235	25	5.4	240	0.8	0.7..0.8Nm	
3NF-30	30 A	270	50	85	240	255	30	5.4	260	1.2	10mm <sup>2</sup> , 1.9..2.2Nm	

\* at 50°C environment temperature

## 7 Brake resistors

### 7.1 General

During braking with the aid of the motor, energy is fed back into the servo amplifier. This regenerative energy is dissipated as heat in the brake resistor. The brake resistor is switched on by the brake circuit. Different resistance values have to be used depending on the servo amplifier. All resistors meet the requirements of CE directives and are UL-registered.

Hints for calculation of the brake power can be found in our Product WIKI on page "[Calculation of brake power](#)", more information to the resistors are given on WIKI page "[Brake Resistors](#)".

### 7.2 Important notes



#### WARNING

The brake resistor surface temperature can exceed 250°C. Risk of burns! Measure the temperature and wait until temperature dropped down below 40°C, before touching the resistor housing.

#### NOTICE

Inadequate levels of cooling air or incorrect installation can lead to overheating and destruction of the resistor and surrounding components.

- May only be installed in switchgear cabinets, comply with the permissible installation types and clearances (see dimensional drawing).
- Ensure there is unobstructed convection for cooling purposes.
- Use temperature-resistant materials in the vicinity of the resistor.
- The connection terminals must never be located within the flow range of the heated waste air.

The following requirements must be met to ensure the brake resistors work properly:

- Compliance with required installation clearances
- Compliance with permissible installation type
- Unhindered access of cooling air
- Unhindered diverting of warmed up air
- Rated data with maximum ambient temperature 40°C, in case of ambient temperature higher than 40°C, power must be reduced by 4% per 10K temperature rise

#### NOTICE

You must read the instructions manual for the servo amplifier/servo motor you are using in your application and observe the safety instructions they contain before commencing mounting/installation work.

A connection diagram appears in the servo amplifier's instructions manual.

### 7.3 Type assignment and order codes

Servo amplifier	Brake resistor	Resistance/ $\Omega$	Remarks
AKD-x00306*	BAFP(U)/BAR(U)/BAS(U)	33	usually required
AKD-x00606*	BAFP(U)/BAR(U)/BAS(U)	33	usually required
AKD-x01206*	BAR(U)/BAS(U)	15	optional
AKD-x02406*	BAR(U)/BAS(U)	15	optional
AKD-x00307*	BAR(U)/BAS(U)	33	optional
AKD-x00607*	BAR(U)/BAS(U)	33	optional
AKD-x01207*	BAR(U)/BAS(U)	33	optional
AKD-x02407*	BAR(U)/BAS(U)	23	optional
AKD-x04807*	BAS(U)	10	usually required
AKD-C01007	BAR(U)/BAS(U)	33	optional

#### Order codes

Article	Amplifier	Resistance [ $\Omega$ ]	Rated Power [W]	Max. Power [W]	Order code
Brake resistor BAS(U) 2000-10	AKD-x04807	10	2000	3200	DE-103874
Brake resistor BAS(U) 3000-10		10	3000	4800	DE-103875
Brake resistor BAS(U) 6000-10		10	6000	9600	DE-103876
Brake resistor BAR(U) 500-15	AKD-x01206 & x02406	15	500	800	DE-201439
Brake resistor BAR(U) 1000-15		15	1000	1600	DE-201440
Brake resistor BAS(U) 2000-15		15	2000	3200	DE-103871
Brake resistor BAS(U) 3000-15		15	3000	4800	DE-103872
Brake resistor BAS(U) 6000-15		15	6000	9600	DE-103873
Brake resistor BAR(U) 600-23		AKD-x02407	23	600	960
Brake resistor BAR(U) 1000-23	23		1000	1600	DE-200614
Brake resistor BAS(U) 2000-23	23		2000	3200	DE-200615
Brake resistor BAS(U) 3000-23	23		3000	4800	DE-200616
Brake resistor BAS(U) 4000-23	23		4000	6400	DE-200617
Brake resistor BAFP(U) 100-33	AKD-x00306 to -x00606 AKD-x00307 to -x01207, AKD-C01007	33	100	160	DE-201437
Brake resistor BAFP(U) 200-33		33	200	320	DE-201438
Brake resistor BAR(U) 250-33		33	250	400	DE-106254
Brake resistor BAR(U) 500-33		33	500	800	DE-106255
Brake resistor BAR(U) 1500-33		33	1500	2400	DE-106258
Brake resistor BAS(U) 3000-33		33	3000	4800	DE-201407

\*= AKD-x means AKD variants -B, -P, -T or -M

### 7.4 External brake resistor BAFP(U)



Protection class: IP40



**WARNING**

The surface temperature can exceed 250°C. Risk of burns and fire! Measure the temperature before touching.

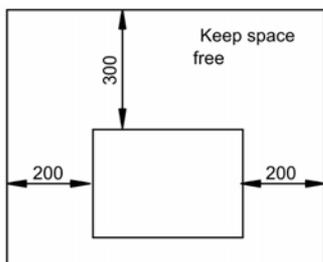
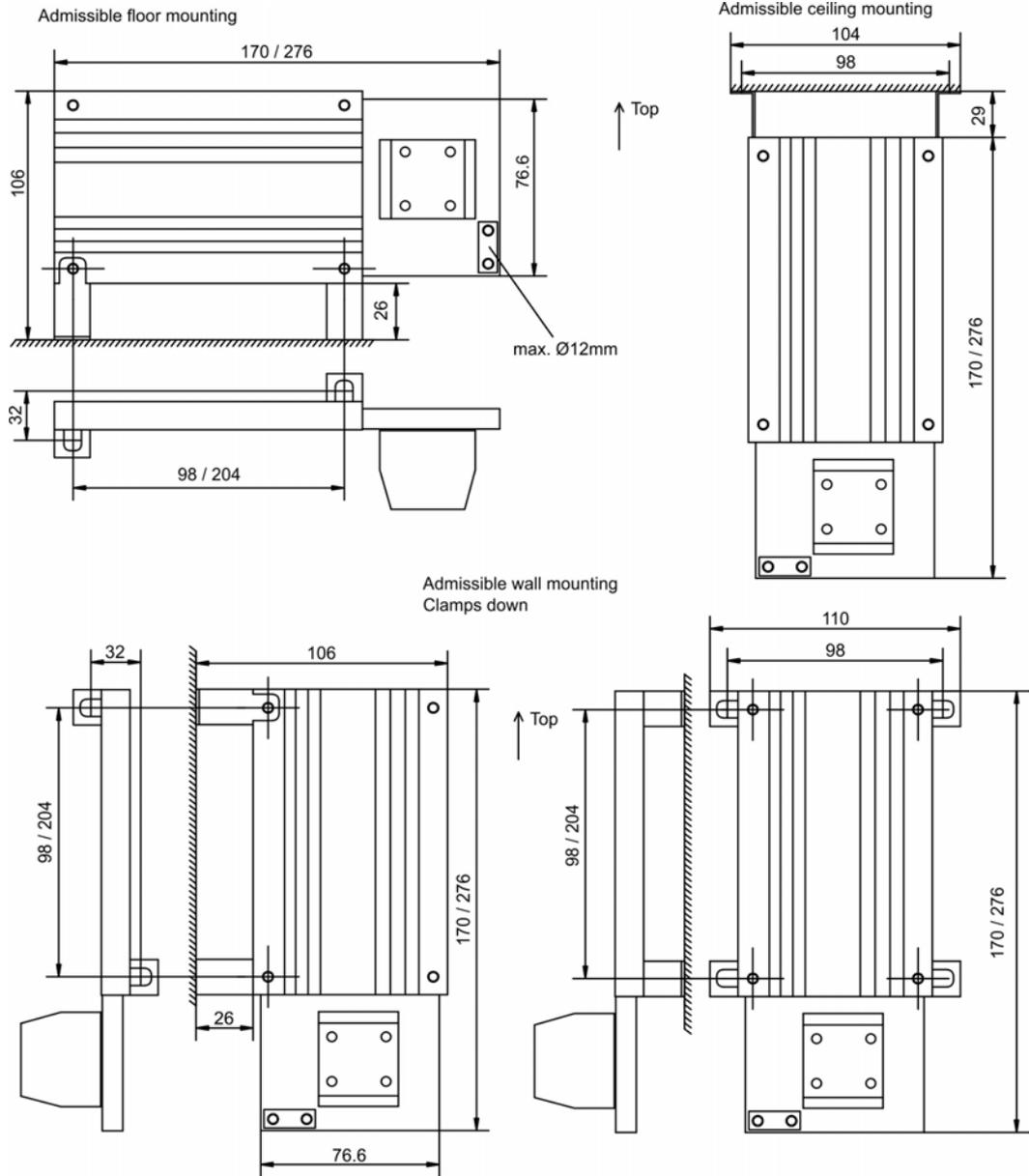

Typ	R	Length	Power	Weight
	Ω	mm	W	Kg
BAFP(U) 100-33	33	170	100	0,3
BAFP(U) 200-33	33	276	200	0,55

Other types of mounting are not admitted !

### 7.5 External brake resistor BAR(U)



Protection class: IP20



The surface temperature can exceed 250°C.  
Risk of burns and fire! Measure the temperature before touching.

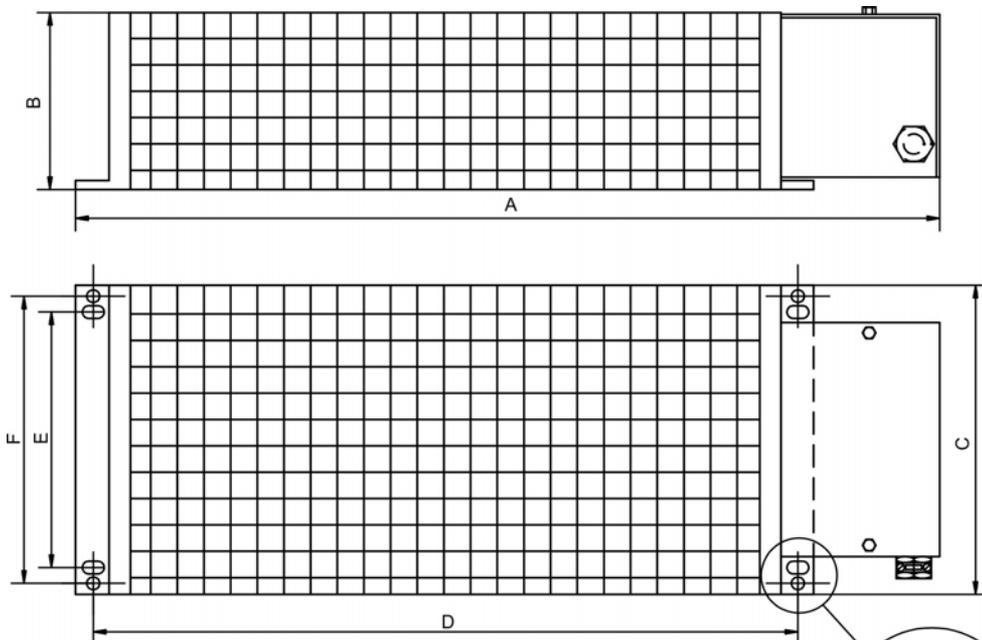

Type	R	Power	A	B	C	D	E	F	weight
	Ω	W	mm	mm	mm	mm	mm	mm	
BAR(U) 500	15	500	549	120	92	430	64	80	3
BAR(U) 1000	15	1000	749	120	92	630	64	80	4
BAR(U) 600	23	600	549	120	92	430	64	80	3
BAR(U) 1000	23	1000	749	120	92	630	64	80	4
BAR(U) 250	33	250	349	120	92	230	64	80	2
BAR(U) 500	33	500	549	120	92	430	64	80	3
BAR(U) 1500	33	1500	649	120	185	530	-	150	5,8
BAR(U) 300	66	300	349	120	92	226	64	80	1,5
BAR(U) 600	66	600	549	120	92	426	64	80	2,3
BAR(U) 1000	66	1000	749	120	92	626	64	80	3,4
BAR(U) 300	91	300	349	120	92	226	64	80	1,5
BAR(U) 600	91	600	549	120	92	426	64	80	2,3
BAR(U) 1000	91	1000	749	120	92	626	64	80	3,4

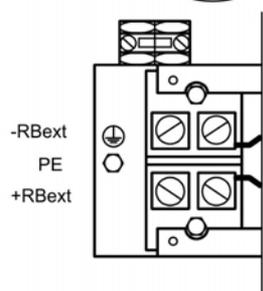
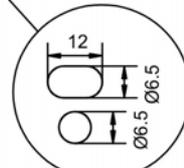

±10%, temperature drift approx. 1%  
Cold approx. +8%, 320°C approx. -7%

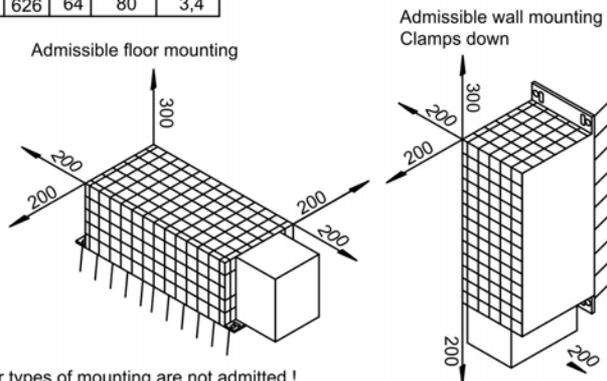

Other types of mounting are not admitted !

## 7.6 External brake resistor BAS(U)



Protection class: IP20



**WARNING**

The surface temperature can exceed 250°C.  
Risk of burns and fire! Measure the temperature before touching.

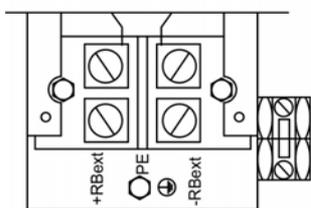
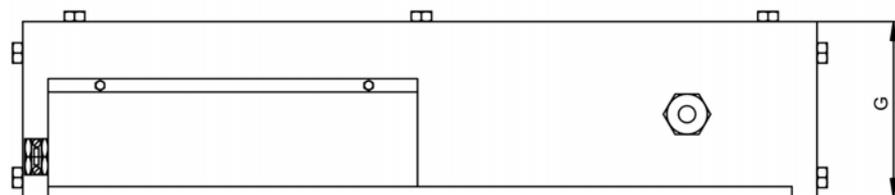
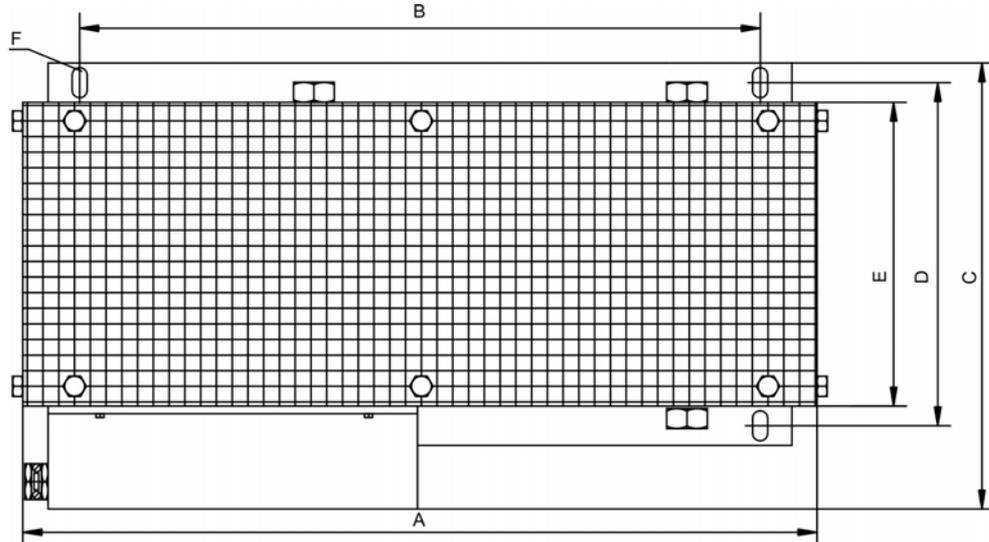

±10%, temperature drift approx. 1%  
Cold approx. +8%, 320°C approx. -7%

Admissible floor mounting

Admissible wall mounting  
Clamps down

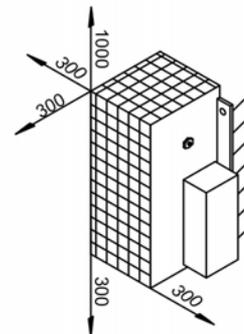
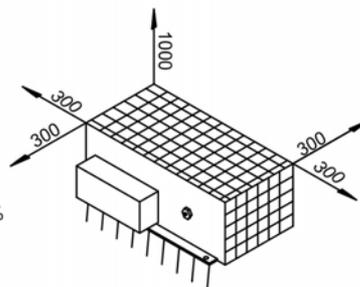

Other types of mounting are not admitted !

	R	Rated power	A	B	C	D	E	F	G	weight
	Ω	W	mm	mm	mm	mm	mm	mm	mm	Kg
BAS(U)2000-10	10	2000	490	380	255	170	150	Ø10,5	260	7
BAS(U)3000-10	10	3000	490	380	355	270	250	Ø10,5	260	8
BAS(U)6000-10	10	6000	490	380	455	370	350	Ø10,5	260	11
BAS(U)2000-15	15	2000	490	380	255	170	150	Ø10,5	260	7
BAS(U)3000-15	15	3000	490	380	355	270	250	Ø10,5	260	8
BAS(U)6000-15	15	6000	490	380	455	370	350	Ø10,5	260	11
BAS(U)2000-23	23	2000	490	380	255	170	150	Ø10,5	260	7
BAS(U)3000-23	23	3000	490	380	355	270	250	Ø10,5	260	8
BAS(U)4000-23	23	4000	490	380	355	270	250	Ø10,5	260	9
BAS(U)3000-33	33	3000	490	380	355	270	250	Ø10,5	260	8

## 8 Capacitor Modules

### 8.1 General

**KCM** modules (**K**OLL**M**ORGEN **C**apacitor **M**odules) absorb energy generated by the motor when it is operating in generator mode. Normally, this energy is dissipated as waste via brake resistors. KCM modules, however, feed the energy they have stored back into the DC Bus link as and when it is required.

<b>KCM-S</b>	Saves energy: The energy stored in the capacitor module during generative braking is available the next time acceleration happens. The module's inception voltage is calculated automatically during the first load cycles.
<b>KCM-P</b>	Power in spite of power failure: If the power supply fails, the module provides the servo amplifier with the stored energy that is required to bring the drive to a standstill in a controlled manner (this only applies to the power supply voltage; battery-back the 24 V supply separately).
<b>KCM-E</b>	Expansion module for both applications. Expansion modules are available in two capacitance classes.

More information can be found on our "European Product WIKI" "[KCM Capacitor Module](#)".

### 8.2 Important notes



#### **DANGER**

DC Bus link terminals in servo systems carry high DC voltage of up to 900 V. Touching the terminals while they are carrying voltage is extremely dangerous. Switch off (disconnect) the line voltage. You must only work on the connections when the system is disconnected.

It can take over an hour for the modules to self-discharge. Check the state of charge with a measuring device that is suitable for a DC voltage of up to 1,000 V. When measuring a voltage of over 50 V between the DC+/DC- terminals or to ground, discharge the modules as described in the KCM Instructions Manual.

#### **NOTICE**

You must read the instructions manual for the servo amplifier/servomotor you are using in your application and observe the safety instructions they contain before commencing mounting/installation work.

Wiring diagram and more important notes concerning wiring can be found in the KCM instructions manual and in the instructions manual of the used servo amplifier.

### 8.3 Type assignment and order codes

**NOTE**

The KCM modules may only be connected to servo amplifiers with 400/480 V rated voltage and a maximum rated current of 24 A.

Servo amplifier	KCM Module	Servo amplifier	KCM Module
AKD-x00306...02406*	not allowed	AKD-x04807	not allowed
AKD-x00307...02407*	all Modules	AKD-C01007	all Modules

\*= x means variants -B, -P, -T or -M

**Order codes**

Type/Order Code	Remarks
KCM-S200-0000	Energy Saving Module, 1.6 kW
KCM-P200-0000	Power Module, 2 kW
KCM-E200-0000	Expansion Module 2 kW
KCM-E400-0000	Expansion Module 4 kW

### 8.4 Example installation

**NOTICE**

Maximum cable length between servo amplifier and KCM: 500 mm. The DC+ and DC- lines should always be twisted, maximum cross section is 6 mm<sup>2</sup>.

RS422 interface X4 allows data exchange controlled by a terminal software of your choice. Interface setting: 115200 Baud, 8 Data Bits, 1 Stop Bit, No Parity&Flow Control. The X4 mating connector is in the package. The ready signal reports the ready to operate (high level).

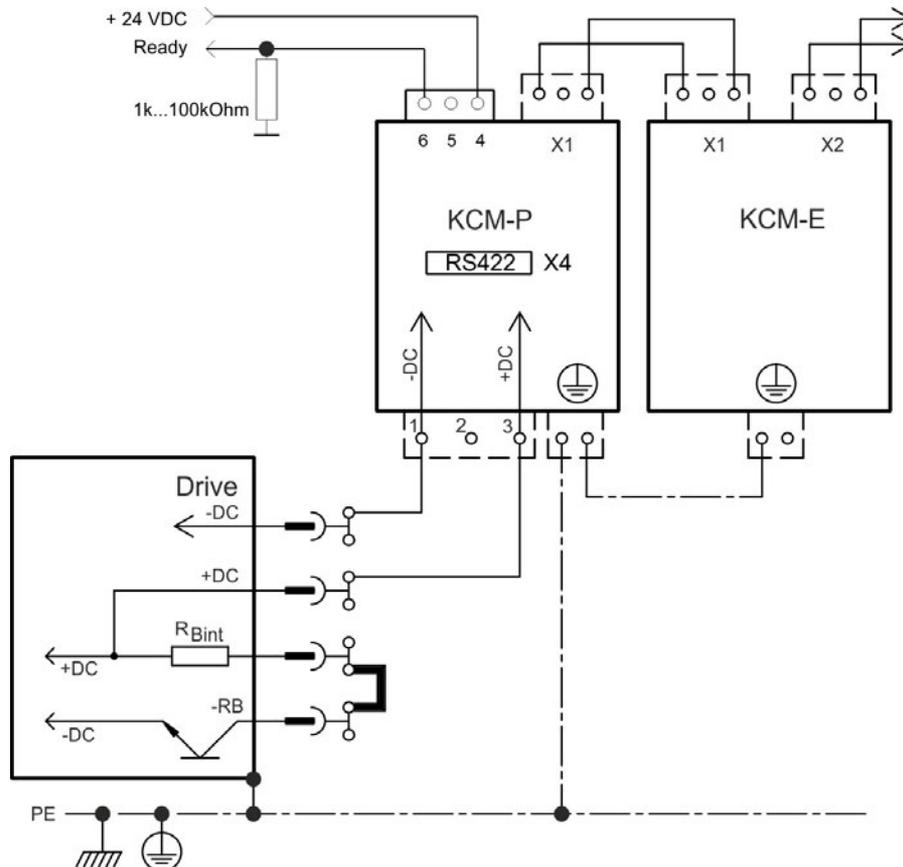

More information is given in the KCM Instructions Manual.

## 8.5 KCM Module



**Observe the safety instructions → p. 29 and in the instruction manual of the servo amplifier.**

Permissible assembly type: Vertical, ground connections at the bottom. Other assembly positions are not permitted. Observe the required free space to next device. Ensure there is unobstructed convection for cooling purposes.

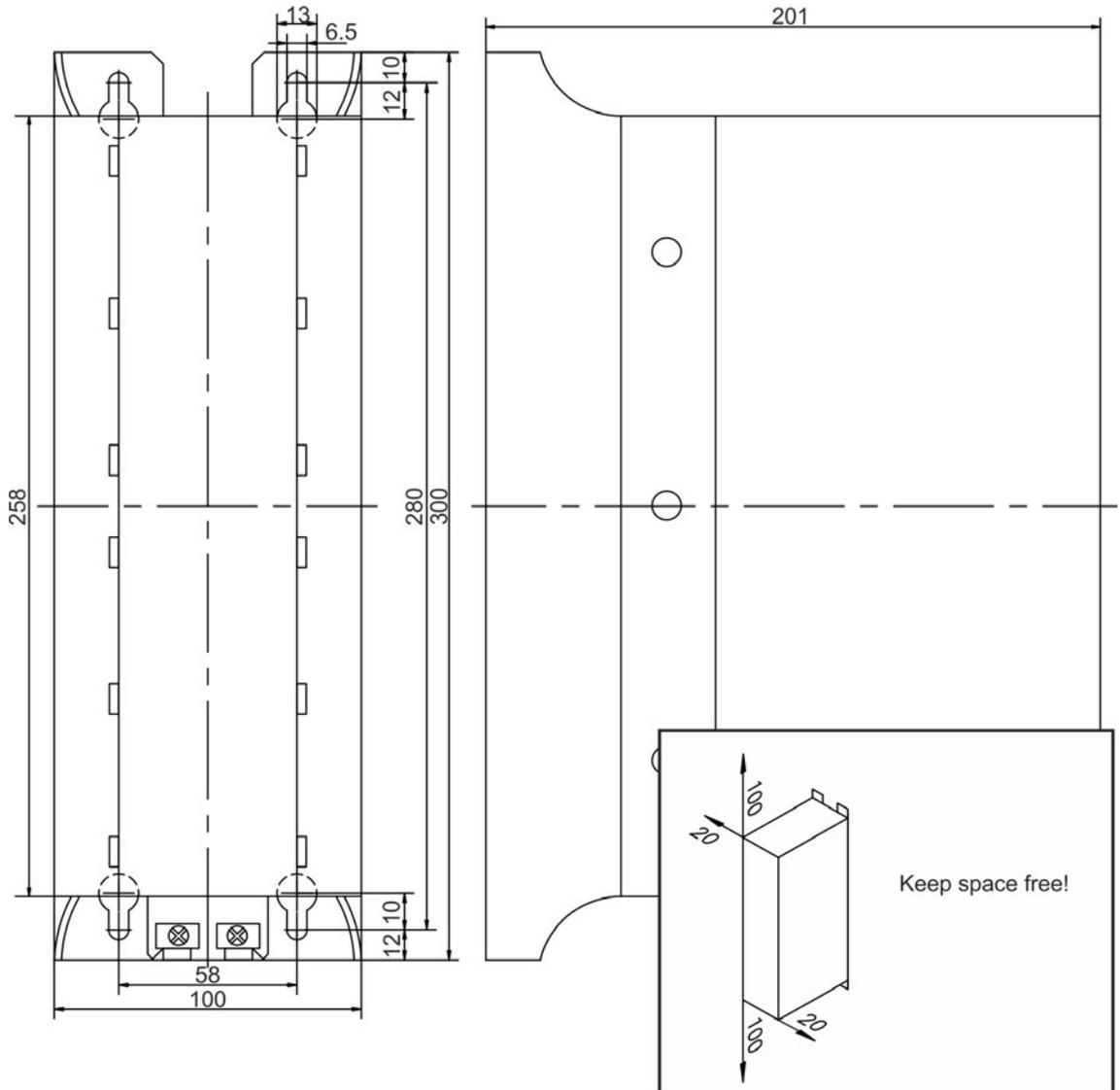

### Technical Data

Type	Storage Capacity [Ws]	Rated supply voltage [V=]	Peak supply voltage [V=]	Power [kW]	Protection Class	Inception voltage [V=]	Weight [kg]
KCM-S200	1600	max 850 VDC	max 950VDC (30s in 6min)	18	IP20	calculated	6.9
KCM-P200	2000					470 VDC	6.9
KCM-E200	2000					-	4.1
KCM-E400	4000					-	6.2

## 9 Motor chokes

### 9.1 General

#### Shielded motor cables

For reasons of electromagnetic compatibility, the motor must be supplied with power via a shielded cable. The structure of a cable with 100% shielding and the capacity equivalent circuit diagram (to earth) are shown below.

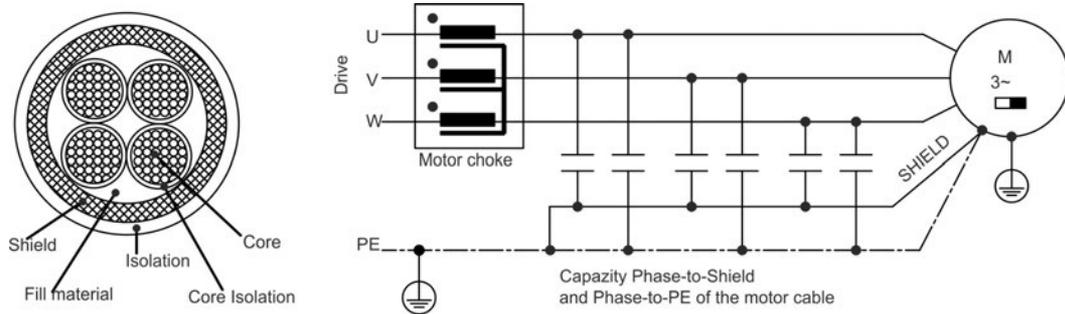

#### Why use motor chokes?

- To compensate high capacitive charge/discharge currents typical of shielded motor cables approximately 25 m and longer.
- To reduce current alternation noise in the motor.
- To reduce current ripple in the motor.

The digital servo amplifiers' high switching frequencies and steep switching edges give rise to the transfer of capacitive currents to the shield by the three phases (U, V, W). These currents flow from the shield to earth. Depending on the cable length and cable capacity (determined by design), this can lead to the generation of shield currents with peak values of up to 20 A.

These shield currents place a load on the servo amplifiers and motor and, on large systems, lead to shifts in potential which can damage other components.

This effect is evident in particular on systems with multiple amplifiers operating in parallel on the same mains filter.

The motor chokes slow down the rate of rise of the motor current (reduce edge steepness), thereby reducing the current transferred to the shield.

#### Why is the cross-section of the motor cable important?

Motor cables longer than 50 m with a small cross-section (e.g. 4 x 1.0 mm<sup>2</sup>) and therefore a higher equivalent resistance are able to reduce the oscillation tendency of the LCR oscillating circuit (amplifier/choke/cable/motor). This cross-section can also be advantageous for cable lengths shorter than 50 m if the cable capacity and motor inductance are very high. However, the current loading of the cable must always be within the limits specified by EN 60204.

## 9.2 Important notes



### CAUTION

The choke can become hot during operation (rising to temperatures in excess of 80° C). Risk of light burns and fire! Therefore, you should make sure that the choke is mounted a sufficient distance away from neighbored components. Provide the requisite conditions for unobstructed convection to cool the choke.

### NOTICE

You must read the instructions manual for the servo amplifier/servo motor you are using in your application and observe the safety instructions they contain before commencing mounting/installation work. This manual is only valid in conjunction with the instructions manual for the servo amplifier and servo motor you are using in your application.

Mount the motor choke 3YLN on a conductive earthed assembly plate in the switchgear cabinet.

The motor choke is wired into the cable close to the amplifier. When laying the motor cable, allow about 400 mm for the connection to the choke.

Connection diagram see the servo amplifier instructions manual.

## 9.3 Type assignment and order codes

Servo amplifier	Motor choke	Condition
AKD-x003 to AKD-x006*	3YLN-06	Motor cable $\geq$ 25m
AKD-x012*	3YLN-14	Motor cable $\geq$ 25m
AKD-x024*	3YLN-24	Motor cable $\geq$ 25m

\*= x means variants -B, -P, -T or -M

### Order codes

Article	Nominal Current	Approvals	Order code
Motor choke 3YLN-06	6 A	CE, UL	DE-107929
Motor choke 3YLN-14	14 A	CE, UL	DE-107931
Motor choke 3YLN-24	24 A	CE, UL	DE-201447

## 9.4 Motor choke 3YLN-xx

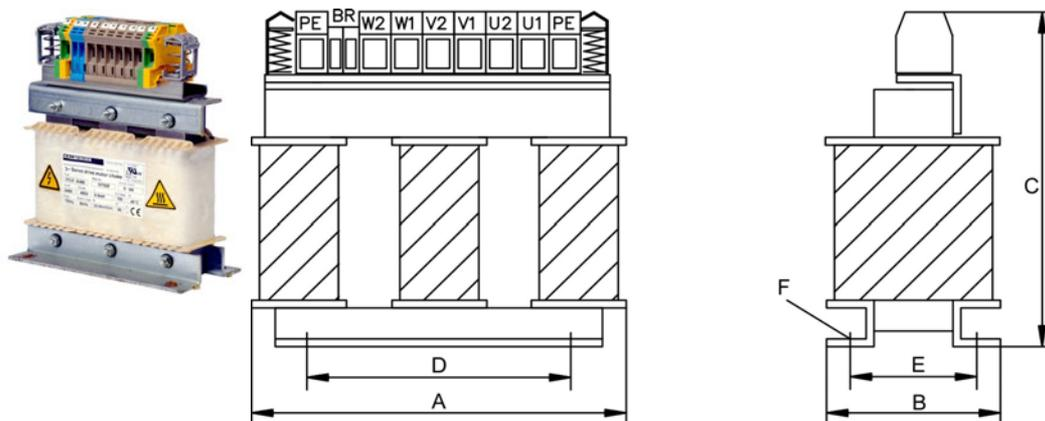

### Technical Data:

Rated Data	Sym	DIM	3YLN-06	3YLN-14	3YLN-24
Rated current	I <sub>0rms</sub>	A	6	14	24
Rated voltage	U <sub>nom</sub>	V	480		
Rated frequency	f <sub>nom</sub>	Hz	0 to 150		
Max. frequency	f <sub>max</sub>	kHz	8		
Inductivity	L	μH	900	900	450
Power loss	P	W	12	19.4	23.2
Protection class	-	-	IP00		
Temperature class	-	-	F		
Operation class	-	-	S1		
Weight	G	kg	4.5	10	10
Cable diameter (Shield clamp)	-	mm	4 to 13.5		
Wiring cross section max. (Terminals)	-	mm <sup>2</sup>	10	16	16
Width	A	mm	155	190	190
Depth	B	mm	90	125	125
Height	C	mm	195	230	230
Mounting hole distance	D	mm	130	170	170
Mounting hole distance	E	mm	56.5	78	78
Mounting screws	F	-	4xM6	4xM6	4xM6

## 10 Cables

**NOTICE**

Kollmorgen assumes no liability for errors or damage to equipment caused by cables manufactured by customers.

### 10.1 Technical data for cables

Information on the chemical, mechanical and electrical characteristics of the cables can be found in our [Technical WIKI \(Cables\)](#).

**Insulation material**

Sheathing: PUR (polyurethane, code 11Y)

Core insulation: PETP (polyesteraphthalate, code 12Y)

**Capacitance (phase to shield)**

Motor cable: less than 180 pF/m (cross sections >6mm<sup>2</sup> have larger capacitance)

Feedback cable: less than 120 pF/m

Hybrid Cable: special requirements

**Technical data**

- The brackets in the core definition indicate the shielding
- All cables are suitable for use as trailing cables
- The technical data refer to use as moveable cables
- Operating life : 10 million bending cycles
- All cables are UL recognized

### 10.2 Tools

Only work with the special tools that are required for the used connectors. You can obtain these special tools from the manufacturer of the connectors or contacts.

### 10.3 PC connection

The AKD is connected by a standards net cable with RJ45 connectors to the PC or to a Switch/Hub.

Article	Order Code
Ethernet Cable PC-AKD	→ p. 40

### 10.4 Power Voltage Supply, external brake resistor, DC bus link

The connectors used (40 A and higher fixed terminals) are included in the scope of supply of the servo amplifier. If necessary, the connectors are coded and printed with the corresponding terminal designation. The table indicates the type of cable required for each intended purpose.

#### NOTE

We do not deliver configured cables for this interface.

#### NOTICE

You must always observe the specifications in respect of cable cross-sections contained in the instructions manual for the servo amplifier you are using in your application. Fit suitable wire end ferrules or plug connectors to stripped conductors. A connection diagram appears in the servo amplifier instructions manual.

#### 10.4.1 Recommended cable type

Purpose	max. length	recommended cable @ amplifier rated output current		
		In=1.5...10A	In=14...24A	In=40...70A
AC-supply*	-	H07V-K 1.5	H07V-K 4	H07VVC4-K 3G 25
DC-bus link*	0.5 m	H07V-K 1.5	H07V-K 4	H07V-K 25
	2m	H07VVC4-K 2X 1.5	H07VVC4-K 2X 4	H07VVC4-K 2X 25
Ext. brake resistor*	5m	H07VVC4-K 2G 1.5		H07VVC4-K 2G 25

\* valid only for single-axis systems. For multi-axis systems, please consult our customer support.

#### 10.4.2 Mating connector (part of delivery)

Amplifier	#	Mains supply		DC-link bus		Brake resistor	
		#	Order Code	#	Order Code	#	Order Code
AKD-x00306/00606*	X3		CON- AKDX3A-SL	X3	CON- AKDX3A-SL	X3	CON- AKDX3A-SL
AKD-x01206*	X3		CON- AKDX3B-SL	X3	CON- AKDX3B-SL	X3	CON- AKDX3B-SL
AKD-x02406	X4		CON- AKDX4-SL	X3	CON- AKDX3C-SL	X3	CON- AKDX3C-SL
AKD-x00307...02407*	X4		CON- AKDX4-SL	X3	CON- AKDX3C-SL	X3	CON- AKDX3C-SL
AKD-x04807*	X4		CON- AKD4807X4-SL	X14	CON- AKD4807X14-SL	X3	CON- AKD4807X3-SL
AKD-C01007	X12		Connector Kit → p. 16	X14	Connector Kit → p. 16	X14	Connector Kit → p. 16

\*= x means variants -B, -P, -T or -M

### 10.4.3 Mating connector (optional)

Amplifier	DC-link bus	
	#	Order Code
AKD-x02406/00307...02407	X3Y	CON-AKDX3C-SL-Y
AKD-x04807	X14Y	CON-AKD4807X14-SL-Y

With Y-connectors you can daisy-chain supply voltage or DC-bus link to several amplifiers. For details see instructions manual of the servo amplifier. The F-connectors are for fast wiring (no screws).



## 10.5 24V auxiliary voltage supply

Connectors are used, that are included in the delivery package of the servo amplifiers. If necessary, the connectors are coded and printed with the corresponding terminal designation.

### NOTE

We do not deliver configured cables for this interface.

### NOTICE

You must always observe the specifications in respect of cable cross-sections contained in the instructions manual for the servo amplifier you are using in your application. Fit suitable wire end ferrules or plug connectors to stripped conductors. A connection diagram appears in the servo amplifier instructions manual.

### 10.5.1 Mating connector (part of delivery)

Amplifier	Connector	Order Code
AKD-B/P/T/M-003...24	X1	CON-AKDX1-SL
AKD-B/P/T/M-04807	X1	CON-AKD4807X1-SL
AKD-C	X13	Connector Kit → p. 16

### 10.5.2 Recommended cable type

Purpose	recommended cable
24V Aux. Voltage	H07V-K 1.5 or H07V-K 2.5
<b>Observe voltage drop!</b>	

## 10.6 Digital/analog Inputs/Outputs

### 10.6.1 Digital In/Outputs for AKD-C

The digital control signals are connected to X15 and X16 with single lines.

**NOTE**

We do not deliver configured cables for this interface.

**Mating connector (part of delivery)**

Amplifier	Digital Signals		STO Signals	
	#	Order Code	#	Order Code
AKD-C	X15	Connector Kit → p. 16	X16	Connector Kit → p. 16

**Recommended cable type**

Purpose	max. length	Recommended cable
Digital I/O, STO	30m	H07VK 0.5

### 10.6.2 Digital In/Outputs for AKD-N



All AKD-N servo amplifiers have one 8 poles M12 connector to connect digital control signals.

Maximum cable length 5m.



AKD-N-DS servo amplifiers (devices with local STO input) have an additional 4 poles M12 connectors to connect the local STO signals.

Maximum cable length 5m.

Kollmorgen recommends pre-configured Phoenix SAC cables.

**Order codes for I/O cables, one end configured**

Amplifier	Order Code	No. of wires	Description
AKD-N all types	SAC-8P-M12MS	8 poles	5m, M12 mating connector, unconfigured wires
AKD-N-DS	SAC-4P-M12MS	4 poles	5m, M12 mating connector, unconfigured wires

Other length can be ordered from Phoenix Contact Deutschland GmbH.

### 10.6.3 Digital/analog I/O for AKD-B/P/T/M

The cables for analog signals must be twisted pairs, and shielded. The digital signals can be connected by single wires.

**NOTE**

We do not deliver configured cables for this interface.

**Mating connector (part of delivery)**

Amplifier	Digital / analog signals				STO Signals	
	#	Order Code	#	Order Code	#	Order Code
<b>AKD-B/P/T</b>	X7	CON-AKDX7-SL	X8	CON-AKDX8-SL	X1	CON-AKDX1-SL
<b>AKD-T-IC</b>	X7	CON-AKDX7-SL	X8	CON-AKDX8-SL	X1	CON-AKDX1-SL
	X21	CON-AKDX21-SL	X22	CON-AKDX22-SL	-	-
	X23	CON-AKDX23-SL	X24	CON-AKDX24-SL	-	-
<b>AKD-M</b>	X7	CON-AKDX7-SL	X8	CON-AKDX8-SL	X1	CON-AKDX1-SL
	X35	CON-AKDX35-SL	X36	CON-AKDX36-SL	-	-

**Recommended cable type**

Purpose	max. length	recommended cable
Digital I/O	10m	H07VK 0,5
BTB	10m	
Digital GND	10m	
Analog Setpoint	25m	LiYCY (TP) 4x2x0.25
Analog GND	25m	

**Color code for shielded cable**

Signal	Color*	Cable
AGND	GY	LiYCY (TP) 4x2x0.25
analog in 1+	WH	
analog in 1-	BN	
analog in 2+	GN	
analog in 2-	YE	
analog out 1	PK	
analog out 2	BU	
AGND	RD	

\* according to IEC 60757

## 10.7 Encoder Emulation, Stepper motor control, Master-Slave

This interface can be used for several applications (see the amplifiers instructions manual). The material requirements are always the same.

### NOTE

We do not deliver configured cables for this interface.

### 10.7.1 Mating connector, cable type

Article	Description	Order Code
Cable	4x2x0.25 (per meter)	DE-92186
Connector kit, amplifier end AKD-B/P/T/M, X9/X10	X10 male connector 15 pin high density, X9 female connector 9 pin, 2 housings, screws	AKD-X9+X10-Kit

### 10.7.2 Connection

The cable used must be shielded, with twisted pairs to (suggestion according to DIN 47100). Since it is important which signal pairs are twisted together, the following table shows the colors of the individual cores (to IEC 60757). The connector assignment is determined by the use of the interface; see the servo amplifier instructions manual.

SubD9, X9 AKD-B/P/T/M	ROD	Core color @ 5x2x0.25 SSI, Stepper motor control, Master-Slave
3	WH	WH
7	GN	n.c.
8	YE	n.c.
1	GY	GN
2	PK	YE
4	BU	GY
5	RD	PK
6	BK	BK
9	BN	n.c.

Connector pin-out depends on the interface usage, see "AKD Instruction Manual".

## 10.8 Ethernet cable

Connection to an Ethernet network is possible via two RJ45 connectors in the servo amplifiers. These cables can be used for all fieldbus connections with standard RJ45 connectors like EtherCAT, PROFINET, SynqNet and also for the EtherNet TCP/IP Service Port connection of an AKDs servo amplifier.

### Order codes Ethernet cable, configured

Article	Length	Order code
Ethernet cable	0.17 m	ENCP-0017-000
Ethernet cable	0.26 m	ENCP-0026-000
Ethernet cable	0.30 m	ENCP-0030-000
Ethernet cable	0.50 m	ENCP-0050-000
Ethernet cable	1.00 m	ENCP-0100-000
Ethernet cable	2.00 m	ENCP-0200-000
Ethernet cable	3.00 m	ENCP-0300-000
Ethernet cable	4.00 m	ENCP-0400-000
Ethernet cable	5.00 m	ENCP-0500-000
Ethernet cable	10.00 m	ENCP-1000-000

## 10.9 CAN bus cable

According to ISO 11898 you should use a bus cable with a characteristic impedance of 120  $\Omega$ . The usable cable length depends on the transmission rate. The values that we have measured can be taken as a guide, but they should not be interpreted as limits:

### Cable data:

- Characteristic impedance: 100-120  $\Omega$
- Cable capacitance: max. 60 nF/km
- Conductor (loop) resistance: 159.8  $\Omega$ /km

### Cable length, depending on the transmission rate:

Transmission rate / kbps	1000	500	250
max. cable length / m	20	70	115

The table refers to the total cable length between the ends of the bus. Longer transmission distances can be achieved with a lower cable capacitance (max. 30 nF/km) and lower loop resistance (115  $\Omega$ /km).



We deliver configured CAN bus cables for AKD-xyyyzz-xxCN and AKD-xyyyzz-xxCC.

Article	Length	AKD Order code
CAN Bus cable	0.15 m	CBP000-002-m15-00
CAN Bus cable	0.30 m	CBP000-002-m30-00
CAN Bus cable	1.00 m	CBP000-002-001-00
CAN Bus cable	3.00 m	CBP000-002-003-00

The CAN Termination connector is required for bus termination of the last AKD connected to the CAN bus. For connecting an AKD to a CAN device with SubD9 connector the CAN RJ12-SubD9 Adapter can be used.

Article	Order code
CAN Termination connector	AKD-CAN-Termination
CAN RJ12->SubD9 adapter	AKD-CAN-RJ12-SubD9

## 10.10 Decentral Drive System Hybrid Cables

### 10.10.1 AKD-C to AKD-N in the decentralized drive system

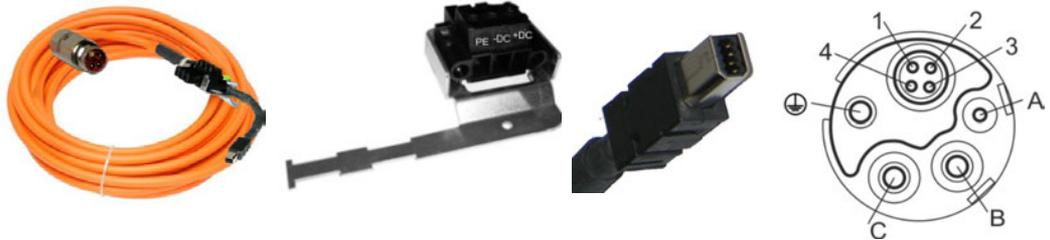

Length definition: xx=meters, yy=centimeters.  
 Define cable lengths: 3 m, 6 m, 12 m, 24 m, 36 m, 40 m  
 Maximum cable length 40 m.

You should use the configured Kollmorgen cables.

<b>(3x2.5+(2x0.25)+(2x0.25))</b>	<b>Usable to connect</b>	<b>Order code</b>
Hybrid Cable	Central power supply AKD-C to AKD-N	CCNCN1-025-xxmyy-00

For replacement issues you can order a connector kit for X20A or X21A with order code CON-AKD-CX20/21A-SL with one connector and one metal shroud.

### 10.10.2 AKD-N to AKD-N in the decentralized drive system

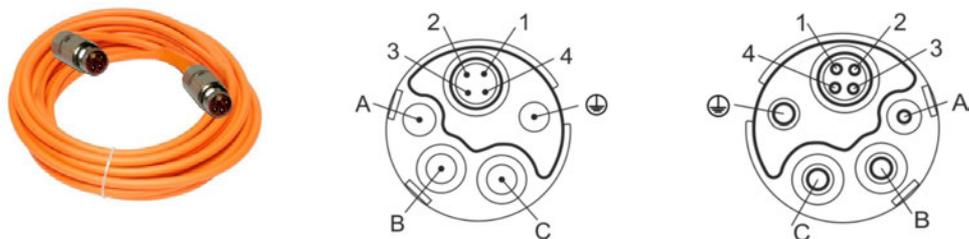

Length definition: xx=meters, yy=centimeters.

Steps:

- 0.25 m steps from 0.25 m to 2 m,
- 0.5 m steps from 2.5 m bis 25 m
- Maximum cable length 25 m.

You should use the configured Kollmorgen cables.

<b>(3x2.5+(2x0.25)+(2x0.25))</b>	<b>Usable to connect</b>	<b>Order code</b>
Hybrid Cable	AKD-N to AKD-N	CCNNN1-025-xxmyy-00

## 10.11 Motor Hybrid Cables

### 10.11.1 AKD to AKM1 Motor (i-tec connector)

You should use the configured Kollmorgen cables.

#### For AKD-B/P/T/M, with shield clamp, i-tec motor connector

AKD-B/P/T/M series servo amplifiers have a 15 pole high density SubD female connector to connect the feedback and a terminal connector for power wiring.

#### NOTE

For SFD3 connection to AKD-B/P/T/M, the feedback connector on the servo amplifier end contains electronics.

Usable for AKM1 (connector option D, feedback options C- and CA). Define the required length in clear text (steps of 1 m). Maximum cable length 25 m.

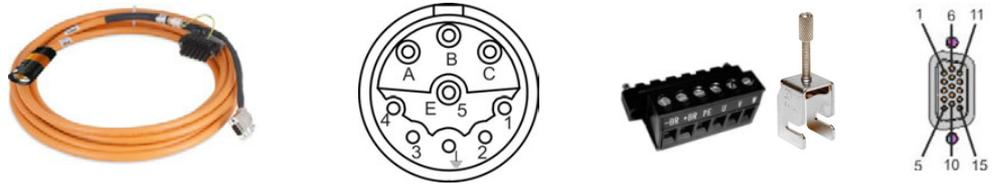

Servo amplifier	(4x1+(2x0.34)+(2x0.75))	Usable to connect	Order code
AKD-B/P/T/M	<b>SFD</b>	AKD-x00306 & x00606* and AKM1 (connector D, feedback C-)	CCS1A3-010-vvv-00
AKD-B/P/T/M	<b>SFD3 &amp; Brake</b>	AKD-x & x* and AKM1 (connector D, feedback CA)	CCJ1A3-010-vvv-00

\*= x means variants -B, -P, -T or -M

#### For AKD-N, i-tec motor connector

AKD-N series servo amplifiers have an 8 pole round connector to connect both motor power and feedback.

Usable for AKM1 (connector option D, feedback option CA).

Maximum cable length 5 m. Length definition: xx=meters, yy=centimeters.

0.2, 0.3, ... , 1.0 (steps 0.1m up to 1m)

1.25, 1.5, ... , 2.0 (steps 0.25m up to 2m)

2.5, 3.0, ... , 5.0 (steps 0.5m up to 5m)



Servo amplifier	(4x1+(2x0.34)+(2x0.75))	Usable to connect	Order code
AKD-N	<b>SFD3 &amp; Brake</b>	AKD-N and AKM1 (connector D, feedback CA)	CCJNA3-010-xxmyy-00

#### NOTICE

AKDNzzz07-DS/DF: For sufficient voltage supply of the feedback system connected to AKD-N/X4, a special connector must be plugged to AKD-N/X5. This special connector is available with order code **AKD-N-JUMP-X5**.

### 10.11.2 AKD to AKM2-6 (M23 connector)

You should use the configured Kollmorgen cables.

#### With shield clamp for AKD-B/P/T/M, motor connector size M23 (up to 22A)

AKD-B/P/T/M series servo amplifiers have a 15 pole high density SubD female connector to connect the feedback and a terminal connector for power wiring. The hybrid cable is splitted to power and feedback cables on the servo amplifier end. The cable shield can be connected to the servo amplifier front with the attached shield clamp.

**NOTE**

For DSL and SFD3 connection to AKD-B/P/T/M, the feedback connector on the servo amplifier end contains electronics.

Usable for AKM2 to AKM6 (connector option D, feedback option C-, CA, GE and GF). Define the required length in clear text (steps of 1 m). Maximum cable length 25 m.

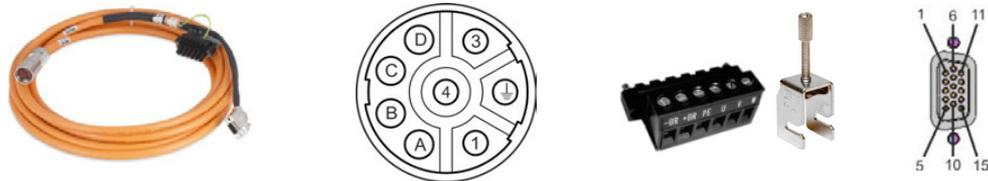

Servo amplifier	(4x1+(2x0.34)+(2x0.75))	Usable to connect	Order code
AKD-B/P/T/M	<b>SFD</b>	AKD-x00306 & x00606* and AKM2-6 (connector D, feedback C-)	CCS1A1-010-vvv-00
AKD-B/P/T/M	<b>SFD3/DSL &amp; Brake</b>	AKD-x00306, x00606, x00307, x00607* and AKM2-6 (connector D, feedback CA, GE, GF)	CCJ1A1-015-vvv-00

\*= x means variants -B, -P, -T or -M

#### For AKD-N, motor connector size M23 (up to 22A)

AKD-N series servo amplifiers have an 8 pole round connector to connect both motor power and feedback. Usable for AKM2 to AKM6 (connector option D, feedback option CA, GE and GF).

Maximum cable length 5 m. Length definition: xx=meters, yy=centimeters.

- 0.2, 0.3, ... , 1.0 (steps 0.1m up to 1m)
- 1.25, 1.5, ... , 2.0 (steps 0.25m up to 2m)
- 2.5, 3.0, ... , 5.0 (steps 0.5m up to 5m)

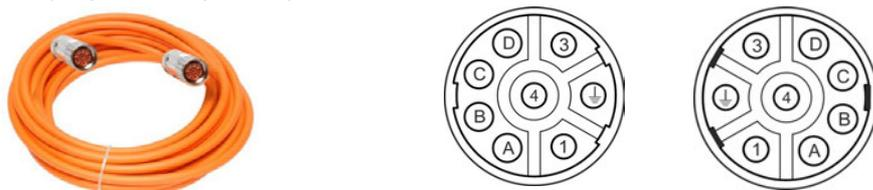

Servo amplifier	(4x1+(2x0.34)+(2x0.75))	Usable to connect	Order code
AKD-N	<b>SFD3/DSL &amp; Brake</b>	AKD-N and AKM2-6 (connector D, feedback CA, GE, GF)	CCJNA1-015-xxmyy-00

**NOTICE**

AKD-Nzzz07-DS/DF: For sufficient voltage supply of the feedback system connected to AKD-N/X4, a special connector must be plugged to AKD-N/X5. This special connector is available with order code **AKD-N-JUMP-X5**.

**With shield plate for AKD-B/P/T/M, motor connector M23 (up to 22A)**

AKD-B/P/T/M series servo amplifiers have a 15 pole high density SubD female connector to connect the feedback and a terminal connector for power wiring. The hybrid cable is splitted to power and feedback cables on the servo amplifier end. The cable shield is automatically connected to the servo amplifier front with the mounted shield plate.

**NOTE**

For DSL and SFD3 connection to AKD-B/P/T/M, the feedback connector on the servo amplifier end contains electronics.

Usable for AKM2 to AKM6 (connector option D, feedback option C-, CA, GE and GF). Define the required length in clear text (steps of 1 m). Maximum cable length 25 m.

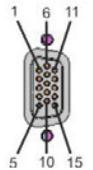
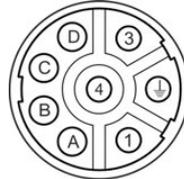

Servo amplifier	(4x1.5+ (2x0.34) (2x0.75))	Usable to connect	Order code
AKD-B/P/T/M	<b>SFD</b>	AKD-x01206* and AKM2-6 (connector D, feedback C-)	CCS2A1-015-vvv-00
AKD-B/P/T/M	<b>SFD3 &amp; Brake</b>	AKD-x01206 & x00307...x01207* and AKM2-6 (connector D, feedback CA)	CCJ2A1-015-vvv-00
AKD-B/P/T/M	<b>DSL &amp; Brake</b>	AKD-x01206 & x00307...x01207* and AKM2-6 (connector D, feedback GE/GF)	CCJ2A1-015-vvv-00

\*= x means variants -B, -P, -T or -M

## 10.12 Motor Power Cables

### 10.12.1 General

Standard versions of Kollmorgen motors have either one connector or one terminal box for the power connection. Optional connection types are described in the relevant motor manual.

Motor series	Power Connection	Motor series	Power Connection
AKM1...8 =< 22A	Connector size M23	VLM2...6	Connector size M23
AKM7...8 > 22A	Connector size M40	Cartridge DDR =< 22A	Connector size M23
AKM8	Terminal box	Cartridge DDR > 22A	Connector size M40
AKMH2...6	Connector size M23		

Depending on their power ratings, Kollmorgen servo amplifiers are equipped with connectors or fixed screw terminals.

Technical data of the used cable material can be found in our "European Product WIKI" [Technical WIKI \(Cables\)](#).

### 10.12.2 Motor cables, configured

The cables differ in respect of how they are connected to the amplifier. There are major differences in connection method due to the varying requirements in respect of minimum code distances, different shielding concepts depending on rated voltage and current load. Our pre-assembled ready-to-use cables meet the requirements of relevant CE and UL directives.

#### NOTE

Different conductor cross-sections are required for different motors, and that for motors with a holding brake the brake signals are also attached through this connector.

#### Connections standard motor connectors

The view is as seen from the contact side of the mating connector.

Standard (M23), wire max 4mm <sup>2</sup>					Option H (M40, wire max. 16mm <sup>2</sup> )				
	Pin	Signal	Pin	Signal		Pin	Signal	Pin	Signal
	1	U2	A	+ Br		U	U2	+	+ Br
	4	V2	B	- Br		V	V2	-	- Br
	3	W2	C	n.c.		W	W2	1	Option J only
	PE (2)	PE	D	n.c.		PE	PE	2	Option J only

#### Material list

Part	Designation	Order Code
Cable	Overview (→ p. 35)	
Connector kit (motor end) M23	EMC Connector 8 poles, M23	DE-92175
Washdown connector kit (motor end) M23	EMC Connector 8 poles, M23, stainless steel	DE-201810
Connector kit (motor end) M40	EMC Connector 6 poles, M40	DE-201601

### 10.12.2.1 Order codes motor cables for AKD-B/P/T/M

**NOTE**

Hybrid cables for motors with one-cable connection → p. 43

**AKD-B/P/T/M, AKM1 motor connector y-tec**

Connects AKD-x00306\* and AKM1 (connector options 1, Y).

Define the required length in clear text (steps of 1m). Length definition vvv=meters. Maximum cable length 50 m, in case of cable length  $\geq 25$  m a motor choke (→ p. 32) should be used.

Cable is delivered with shield clamp.

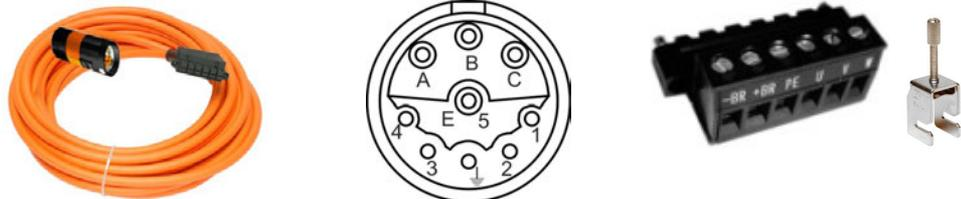

Article	Order code
Motor cable (4x1)	CM01A3-010-vvv-00
Motor cable (4x1+(2x1))	CM11A3-010-vvv-00

\*= x means variants -B, -P, -T or -M

**AKD-B/P/T/M, AKM1 motor connector y-tec**

Connects AKD-x00307\* and AKM1 (connector options 1, Y).

Define the required length in clear text (steps of 1m). Length definition vvv=meters. Maximum cable length 50 m, in case of cable length  $\geq 25$  m a motor choke (→ p. 32) should be used.

Drive connector with mounted shield plate.

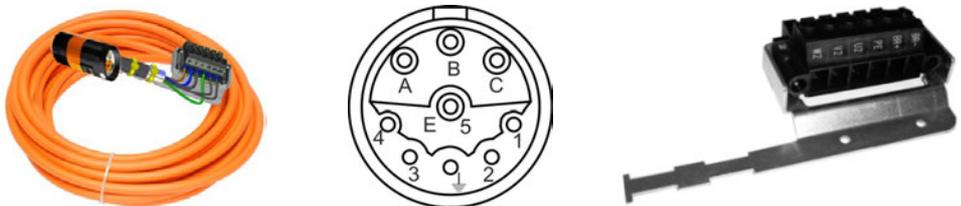

Article	Order code
Motor cable (4x1)	CM02A3-010-vvv-00
Motor cable (4x1+(2x1))	CM12A3-010-vvv-00

\*= x means variants -B, -P, -T or -M

**With shield clamp for AKD-B/P/T/M, motor connector size M23 (up to 22A)**

Connects AKD-x00306\* & x00606\* and AKM1 to AKM7 (connector options 1, 7, B, C, G)  
 Define the required length in clear text (steps of 1m). Length definition vvv=meters. Maximum cable length 50 m, in case of cable length  $\geq$  25 m a motor choke ( $\rightarrow$  p. 32) should be used.

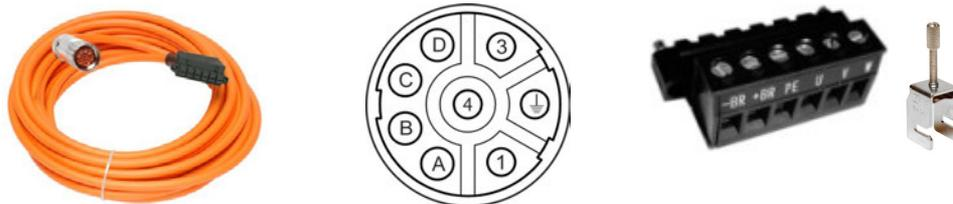

Article	Order code
Motor cable (4x1)	CM01A1-010-vvv-00
Motor cable (4x1+(2x1))	CM11A1-010-vvv-00

\*= x means variants -B, -P, -T or -M

**With shield plate for AKD-B/P/T/M, motor connector size M23 (up to 22A)**

Connects AKD-x01206\* & 02406\*, AKD-x00307...x02407\* and AKM1 to AKM7 (connector options 1, 7, B, C, G).  
 Define the required length in clear text (steps of 1m). Length definition vvv=meters. Maximum cable length 50 m, in case of cable length  $\geq$  25 m a motor choke ( $\rightarrow$  p. 32) should be used.

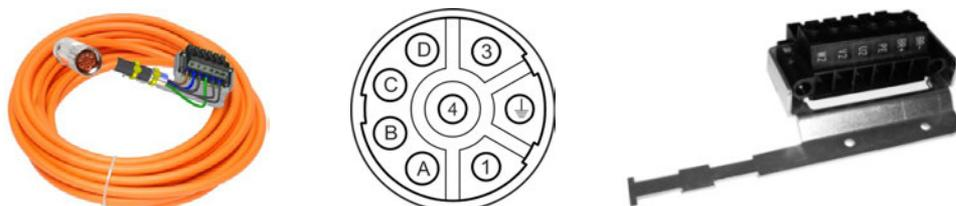

Article	Order code
Motor cable (4x1.5)	CM02A1-015-vvv-00
Motor cable (4x1.5+(2x1))	CM12A1-015-vvv-00
Motor cable (4x2.5)	CM02A1-025-vvv-00
Motor cable (4x2.5+(2x1))	CM12A1-025-vvv-00
Motor cable (4x4)	CM02A1-040-vvv-00
Motor cable (4x4+(2x1))	CM12A1-040-vvv-00

\*= x means variants -B, -P, -T or -M

**With shield plate for AKD-B/P/T/M-024, motor connector size M40 (> 22A)**

Connects AKD-x02406\* & x02407\* and AKM7xQ / AKM82T (connector options 1, H). Define the required length in clear text (steps of 1m). Length definition vvv=meters. Maximum cable length 50 m, in case of cable length  $\geq 25$  m a motor choke ( $\rightarrow$  p. 32) should be used.

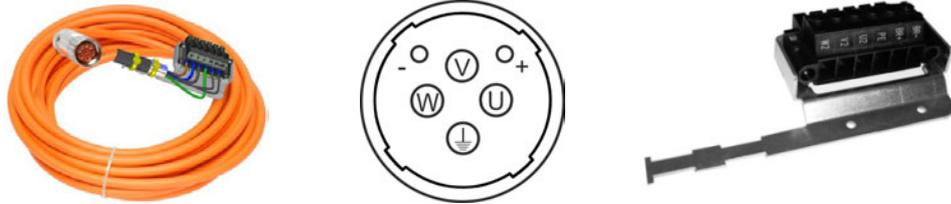

Article	Order code
Motor cable (4x6)	CM02A4-060-vvv-00
Motor cable (4x6+(2x1.5))	CM12A4-060-vvv-00

\*= x means variants -B, -P, -T or -M

**With shield plate for AKD-B/P/T/M-048, motor connector size M40 (> 22A)**

Connects AKD-x04807\* and AKM7xQ / AKM82T (connector options 1, H). Define the required length in clear text (steps of 1m). Length definition vvv=meters. Maximum cable length 25 m.

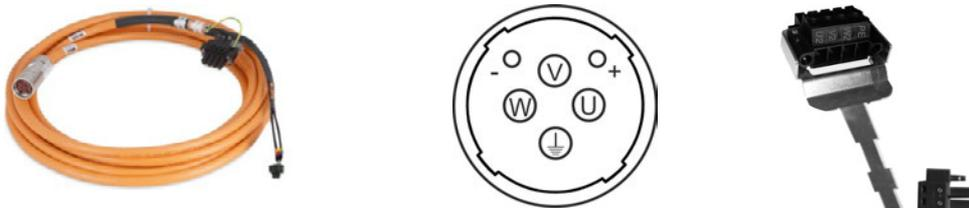

Article	Order code
Motor cable (4x10+(2x1.5))	CM13A4-100-vvv-00
Motor cable (4x16+(2x1.5))	CM13A4-160-vvv-00

\*= x means variants -B, -P, -T or -M

**10.12.2.2 Order codes motor cables for AKD-N**

**NOTE**

Hybrid cables for motors with one-cable connection → p. 43  
 Maximum cable length 5 m. Define the required length in clear text.  
 Length definition: xx=meters, yy=centimeters  
 0.2, 0.3, ... , 1.0 (steps 0.1m up to 1m)  
 1.25, 1.5, ... , 2.0 (steps 0.25m up to 2m)  
 2.5, 3.0, ... , 5.0 (steps 0.5m up to 5m)

**Round connector for AKD-N, AKM1 motor connector y-tec**

Connects AKD-N and AKM1 (connector options 1, Y).

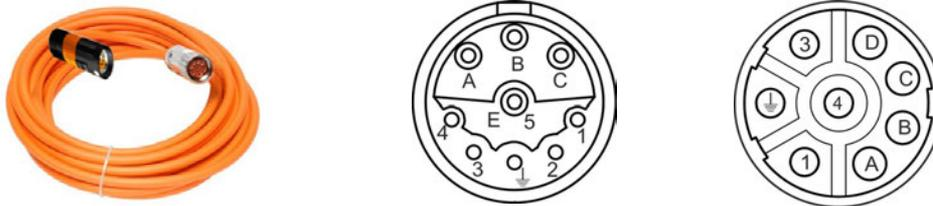

Article	Order code
Motor cable (4x1)	CM0NA3-010-xxmyy-00
Motor cable (4x1+(2x1))	CM1NA3-010-xxmyy-00
Motor cable (4x1.5)	CM0NA3-015-xxmyy-00
Motor cable (4x1.5+(2x1))	CM1NA3-015-xxmyy-00

**Round connector for AKD-N, motor connector size M23 (up to 22A)**

Connects AKD-N and AKM1 to AKM5 (connector options 1, 7, B, C, G)

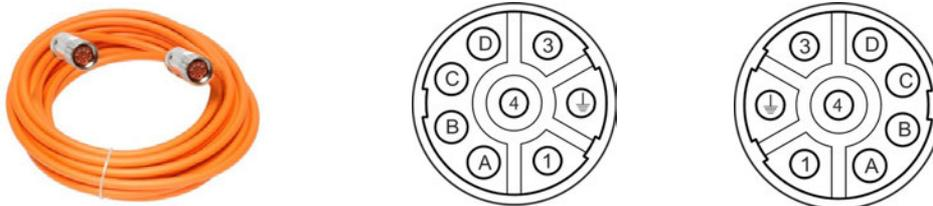

Article	Order code
Motor cable (4x1)	CM0NA1-010-xxmyy-00
Motor cable (4x1+(2x1))	CM1NA1-010-xxmyy-00
Motor cable (4x1.5)	CM0NA1-015-xxmyy-00
Motor cable (4x1.5+(2x1))	CM1NA1-015-xxmyy-00

### 10.12.3 Preparing motor cables (motor end)

#### 10.12.3.1 Motor series AKM1...8 with M23 or M40 connector

Motors with connectors should be connected with our pre-assembled cables.

#### 10.12.3.2 Motor series AKM8 with terminal box

These motors are fitted with terminal boxes, in which there are bolts or terminals for connections. The terminal boxes have 2 screw glands, so that the power and brake cables can be routed separately. If a motor cable with integral brake is used, the unused screw gland must be replaced by a blanking plug. Please refer to the instructions manual for the motor series.

#### Preparing cables for terminal box, separate cables

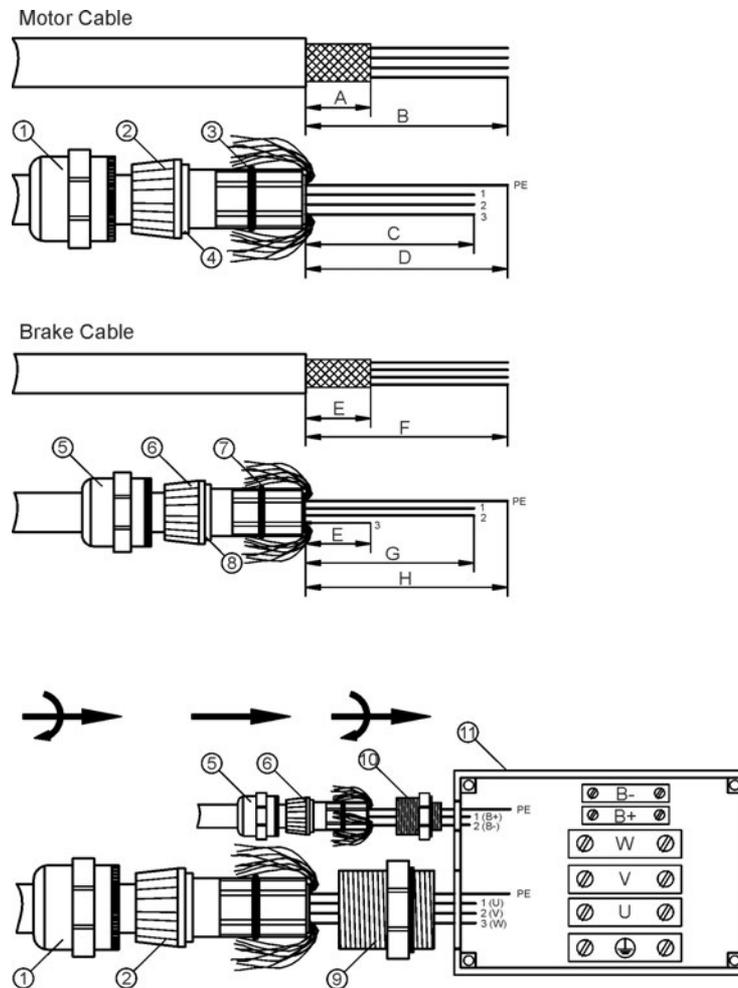

Remove the outer covering over length B, without damaging the shielding braid. Shorten the shielding braid to length A.

Push the union nut (1) and the clamping ring (2) onto the cable and push the shielding braid back over the clamping ring. The shielding braid must cover the sealing ring (3), but must not stick out over the sealing edge (4). Cut off the cores to lengths C and D.

Remove the outer covering over length F, without damaging the shielding braid. Shorten the shielding braid to length E.

Push the union nut (5) and the clamping ring (6) onto the cable and push the shielding braid back over the clamping ring. The shielding braid must cover the sealing ring (7), but must not stick out over the sealing edge (8). Cut off the cores to lengths E/G/H. Remove the insulation from core 3 and lay it over the shielding braid.

Screw the threaded sleeve (9) or (10) into the terminal box (11, example: AKM8 Motor). Push the cores of the cables and the clamping rings (2) or (6) through the threaded sleeve and screw the union nut (1) or (5) tightly onto the threaded sleeve. Then fit bootlace ferrules or terminal pins to the ends of the cores for the brake connections, and ring terminals to the power connections and the PE.

A	B	C	D	E	F	G	H	Connection
20	140	110	140	20	140	130	140	Terminals (similar to drawing)

**Preparing cables for terminal box, combined cables (AKM8)**

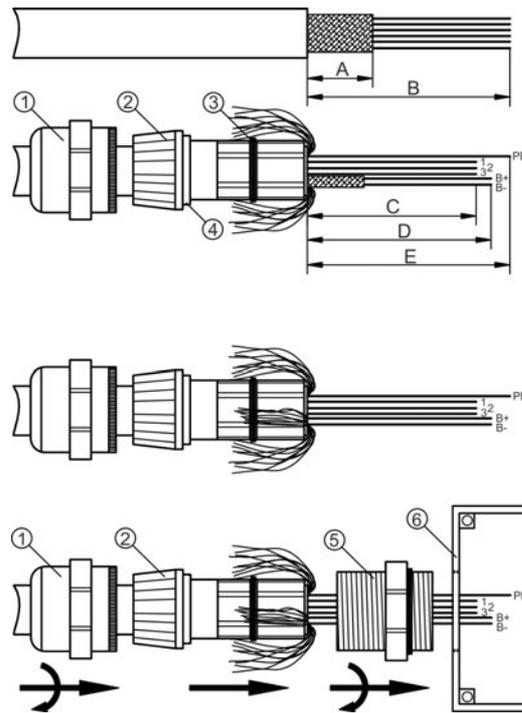

Remove the outer covering over length B, without damaging the shielding braid. Shorten the shielding braid to length A.

Push the union nut (1) and the clamping ring (2) onto the cable and push the shielding braid back over the clamping ring. The shielding braid must cover the sealing ring (3), but must not stick out over the sealing edge (4). Cut off the cores to lengths C/D/E. Shorten the shielding braid for the brake cores to length A.

Push the shielding braid for the brake cores back over the clamping ring. The braid must cover the sealing ring (3) but must not stick out over the sealing edge (4).

Screw the threaded sleeve (5) into the terminal box (6, example: AKM8 Motor). Push the cores of the cable and the clamping ring (2) through the threaded sleeve and screw the union nut (1) tightly onto the threaded sleeve.

Then fit, depending on the motor type, bootlace ferrules or ring terminals to the ends of the cores.

A	B	C	D	E	Connection
20	140	110	130	140	Terminals

### 10.12.4 Preparing motor cables (servo amplifier end), AKD-B/P/T/M

#### Material list

Part	Description	Order code
Cable	Overview (→ p. 35)	
Connector kit amplifier end AKD-x00306/x00606*, SK14	Power Combicon X2	AKD-X2+SK14-Kit
Connector kit amplifier end AKD-x01206/x02406/x00307-x02407*	Power Combicon X2	AKD-X2+Shield-Kit
Connector kit amplifier end AKD-x04807*	Power Combicon X2, Combicon X15 & X16	AKD-X2-X15-X16+ Shield-Kit

\*= X means variants -B, -P, -T or -M

#### Connection scheme

Pin assignment is described in the instructions manual for the servo amplifier.

#### 10.12.4.1 Preparing cables for AKD-x00306/x00606

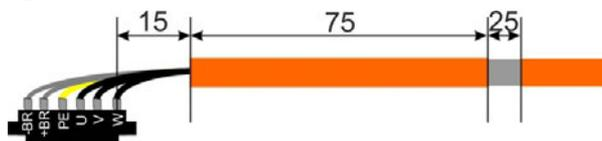

The motor is connected to the AKD-x00306/x00606 with a connector (→ p. 53). Please take note that the connector can accept a maximum conductor cross-section of 4 mm<sup>2</sup>.

Use a shielding clamp (→ p. 17) to ensure an optimum shield connection to the servo amplifier.

Wire the connector as shown in the connection diagram in the installation manual. Plug in the connector to the socket on the front of the servo amplifier. Screw the connector in place.

### 10.12.4.2 Preparing cables for AKD-x01206/x02406/x00307 to x02407

The motor is connected to the AKD-x01206/x02406/x00307-x02407 by a Power Combicon connector (→ p. 53). You can obtain the connector kit from us (with connector, shield plate, rubber bushes, installation material).

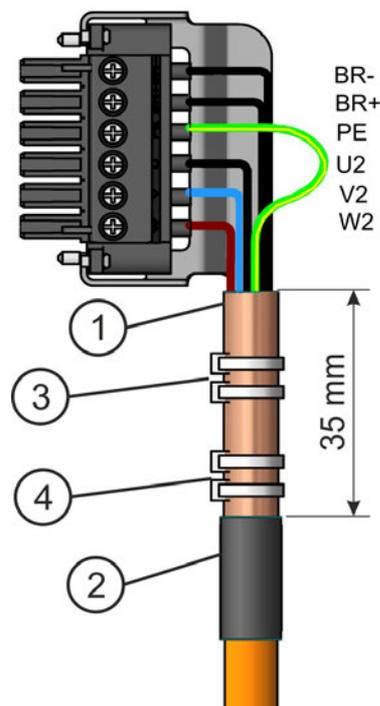

Strip the external cable sheath to a length of approx. 120 mm, taking care not to damage the braided shield. Push the braided shield (1) back over the cable and secure with a rubber sleeve (2) or shrink sleeve.

Shorten all the wires apart from the protective earth (PE) wire (green/yellow) by about 20 mm so that the PE wire is now the longest wire. Strip all wires and fit wire end ferrules.

Secure the braided shield of the cable to the shroud with a cable tie or a hose clamp (3) and use a second tie (4) to fasten the cable.

Wire the connector as shown in the connection diagram. Plug in the connector to the socket on the front of the AKD.

**Screw the connector in place.** This ensures that there is conductive contact over a large surface area between the braided shield and the front panel.

### 10.12.4.3 Preparing cables for AKD-x04807

The motor is connected to the AKD-x04807 by two Combicon connectors (→ p. 53) either with a combined cable or with two separate cables. You can obtain the connector kit from us.

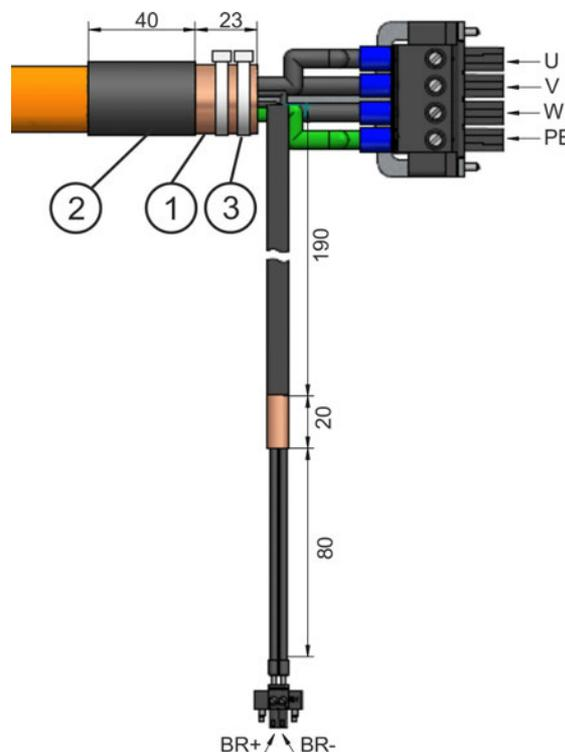

Strip the external cable sheath to a length of approx. 300 mm, taking care not to damage the braided shield. Push the braided shield (1) back over the cable and secure with a rubber sleeve (2) or shrink sleeve.

Split the power wires and brake wires.

Secure the braided shield of the cable to the shroud with cable ties or hose clamps (3) to fasten the cable.

#### Power wires:

Shorten all power wires to a length of approx. 100 mm. Shorten all the wires apart from the protective earth (PE) wire (green/yellow) by about 20 mm so that the PE wire is now the longest wire. Strip all wires and fit wire end ferrules.

#### Brake wires

Secure the shielded brake wires to a length of approx. 190 mm. Shorten the shield to a visible length of about 20 mm (used for shield connection to the drive). Strip the wires and fit wire end ferrules.

Wire the connectors (X2 and X16) as shown in the drive connection diagram. Plug in and screw the connector to the sockets on the bottom of the AKD-x04807.

## 10.13 Motor Feedback Cables

The motor feedback should be connected with pre-assembled Kollmorgen cables. The cable shield is connected to servo amplifier and motor via the connector housings.

### 10.13.1 Resolver cables

All our standard motors feature the same 12-pin connector (M23) for the resolver connection. The AKM1 motor optionally supports a y-tec connector.

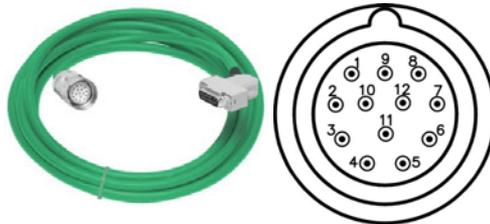

CFR0A1-002-vvv

The AKD-B/P/T/M series servo amplifiers have a 15 pole high density Sub-D female connector for the connection of a resolver and the thermal protection sensor.

Length definition: vvv=meters.

Maximum cable length: 100 m.

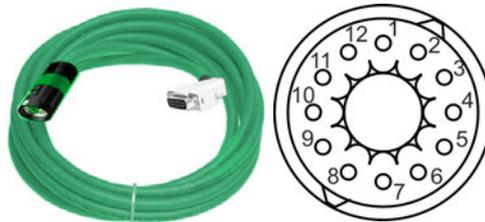

CFR0A3-002-vvv

#### Order codes for resolver cables, pre-assembled

Amplifier	(4x(2x0.25))	Order code	Length
AKD-B/P/T/M	Resolver Cable M23	CFR0A1-002-vvv-00	Steps of 1m up to 100m
AKD-B/P/T/M	Resolver Cable y-tec	CFR0A3-002-vvv-00	Steps of 1m up to 100m

Define the required length in clear text.

AKD-N does not support Resolver feedback.

### 10.13.2 SFD cables

On the motor end two connectors are available: standard Kollmorgen M23 or y-tec for AKM1.



CFS0A1-002-vvv

CFS0A3-002-vvv

The AKD-B/P/T/M series servo amplifiers have a 15 pole high density Sub-D female connector for the connection of an SFD feedback. Length definition: vvv=meters. Maximum cable length 50 m.



CFSNA1-002-xxmyy CFSNA3-002-xxmyy

The AKD-N-DF/DS series servo amplifiers have a round connector to connect an SFD feedback. Length definition: xx=meters, yy=centimeters. Maximum cable length: 5 m.

#### Order codes for SFD cables, pre-assembled

Amplifier	(2x(2x0.25))	Order code	Length
AKD-B/P/T/M	SFD Cable M23	CFS0A1-002-vvv-00	Steps of 1 m up to 50 m
AKD-B/P/T/M	SFD Cable y-tec	CFS0A3-002-vvv-00	Steps of 1 m up to 50 m
AKD-N-DF/DS	SFD Cable M23	CFSNA1-002-xxmyy-00	0.1m steps from 0.2m to 1m, 0.25m steps from 1.25m to 2m
AKD-N-DF/DS	SFD Cable y-tec	CFSNA3-002-xxmyy-00	0.5m steps from 2.5 to 5m

Define the required length in clear text.

### 10.13.3 Encoder cables

All the standard motors in our range feature the same 17-pin M23 connector for the encoder connection (EnDat, HIPERFACE, BiSS etc.).

The AKM1 motor optionally supports a 12 pin y-tec connector for Hiperface encoder only.



CFx0A1-002-vvv CFH0A3-002-vvv

The AKD-B/P/T/M series servo amplifiers have a 15 pole high density Sub-D female connector for the primary feedback connection of an encoder and the thermal protection sensor.

Maximum cable length: 50 m. (BiSSC max. 25m)  
Length definition: vvv=meters.



CFD5A1-002- vvv

The AKD-B/P/T/M series servo amplifiers offer a second feedback interface with a 9 pole Sub-D male connector for the connection of an EnDAT 2.2 encoder as primary feedback. The thermal protection must be connected to a digital input located on connector X8.

Maximum cable length: 50 m.  
Length definition: vvv=meters.



CFxNA1-002-xxmyy CFHNA3-002-xxmyy

The AKD-N-DF/DS series servo amplifiers have a round connector to connect an encoder feedback and the thermal protection sensor.

Maximum cable length: see table below.  
Length definition: xx=meters, yy=centimeters.

#### Order Codes Encoder cables, configured

Amplifier	(7x(2x0.25))	Order codes			Length, Remarks
		EnDat 2.2, BiSS C	EnDat 2.1, BiSS B	Hiperface	
AKD-B/P/T/M	Encoder cable M23	CFD0A1-002-vvv-00	CFE0A1-002-vvv-00	CFH0A1-002-vvv-00	Steps of 1 m up to 50 m
AKD-B/P/T/M	Encoder cable y-tec	-	-	CFH0A3-002-vvv-00	Steps of 1 m up to 50 m
AKD-B/P/T/M	Encoder cable M23	CFD5A1-002-vvv-00	-	-	Steps of 1 m up to 50 m
AKD-N-DF/DS	Encoder cable M23	CFDNA1-002-xxmyy-00 max. 5m	CFENA1-002-xxmyy-00 max. 5m	CFHNA1-002-xxmyy-00 max. 5m	0.1m steps from 0.2m to 1m, 0.25m steps from 1.25m to 2m
AKD-N-DF/DS	Encoder cable y-tec	-	-	CFHNA3-002-xxmyy-00 max. 5m	0.5m steps from 2.5 to 5m

Define the required length in clear text.

### 10.13.4 ComCoder cables

On the motor end two connector types are possible for the comcoder connection (incremental encoder with Hall sensors):

- 17-pin M23 connector for AKM1 to AKM8 or
- 15-pin y-tec connector for AKM1.



CFC0A1-002-vvv

CFC0A3-002-vvv

The AKD-B/P/T/M series servo amplifiers have a 15 pole high density Sub-D female connector for the connection of a ComCoder and the thermal protection sensor. Length definition: vvv=meters. Maximum cable length 25 m.



CFCNA1-002-xxmyy CFCNA3-002-xxmyy

The AKD-N-DF/DS series servo amplifiers have a round connector to connect a ComCoder and thermal protection sensor. Length definition: xx=meters, yy=centimeters. Maximum cable length see table below.

#### Order Codes ComCoder cables, configured

Amplifier	(8x(2x0.25))	Order code	Length
AKD-B/P/T/M	Comcoder cable M23	CFC0A1-002-vvv-00	Steps of 1 m up to 25 m
AKD-B/P/T/M	Comcoder cable y-tec	CFC0A3-002-vvv-00	
AKD-N-DF/DS	Comcoder cable M23	CFCNA1-002-xxmyy-00	0.1 m steps from 0.2 m to 1m, 0.25m steps from 1.25m to 2m 0.5m steps from 2.5 to 5m
AKD-N-DF/DS	Comcoder cable y-tec	CFCNA3-002-xxmyy-00	

Define the required length in clear text.

## 11 Record of Document Revisions

Edition	Comments
04/2007	First edition
07/2007	System S700 updated.
11/2007	Several corrections, connectors added.
03/2008	Motor cable 1mm <sup>2</sup> for S700 added, Symbols acc. to ANSI Z535, Y-Connector X0/X8 for S700 added, configuration of cables, 3YL20->3YL24.
04/2010	Weight 3YL-24, Product brand, 3YL20 with UL, 3YLN new, S748/772, AKD, Resolver table, S200 accessories removed.
12/2010	Order codes brake resistors, Comcoder wire colors, feedback cable color, order codes motor cables, mains filter new types, mains chokes new types, transport tool for AKM8, mounting clamps for S700, accessories S640/670 removed, 3YL20 removed, company name.
10/2011	Motor cables, cable data, EU order codes mating connectors AKD, AKD Hiperface.
03/2012	Order codes motor cables S748/772 updated, cable data, combined cables for AKD with SFD, stainless steel connectors for Washdown motors.
08/2012	SFD cable fotos, all SFD cables to one section, dimensions mains chokes corrected, capacitor modules new, formal improvements
05/2013	Photos SFD cables, dimensions mains chokes updated, KCM modules new, manufacturing hints for Kollmorgen cables removed, configured cable tables with photos, typo corrections, fan kit AKM7, mains filter 1NF-20 replaced by 1NF-20B, mounting clamps S700 removed, 24V mains supply removed, hybrid cables new
11/2013	Heat sink AKD-N new, Hybrid cables AKD-C/N new, Hybrid cables SFD3/DSL, new Ethernet cables
03/2014	New Layout, AKMH mounting kit, KCM updated, AKM7 Fan-Kit updated, hybrid cables SFD3/DSL added
05/2014	Length definition of hybrid cables for decentralized systems changed, S700 X8Y set with X4Amini
08/2014	Brake resistor AKD-x01206 changed, length definitions for decentral hybrid cables updated
12/2014	S640/670 added, AKD-x04807 accessories added
09/2015	Motor cables for AKD-x04807 added, mating connector X5-JUMP for AKD-N new, cabinet connector coupling for decentral drive system removed, notes for slip rings and IP67 grommets, revision history restructured, CFD5A1 cable added. Accessories Manual splitted to AKD and Sxyz versions. First AKD-only revision.

## Service

We are committed to quality customer service. In order to serve in the most effective way, please contact your local sales representative for assistance.

If you are unaware of your local sales representative, please contact the Customer Support.

### Europe

KOLLMORGEN Customer Support Europe

Internet: [www.kollmorgen.com/uk](http://www.kollmorgen.com/uk)

E-Mail: [technik@kollmorgen.com](mailto:technik@kollmorgen.com)

Tel.: +49 (0)2102 - 9394 - 0

Fax: +49 (0)2102 - 9394 - 3155



KOLLMORGEN  
UK Website



European  
Product WIKI

### North America

KOLLMORGEN Customer Support North America

Internet: [www.kollmorgen.com](http://www.kollmorgen.com)

E-Mail: [support@kollmorgen.com](mailto:support@kollmorgen.com)

Tel.: +1 - 540 - 633 - 3545

Fax: +1 - 540 - 639 - 4162



KOLLMORGEN  
US Website



KOLLMORGEN  
Developer Network

### Asia

KOLLMORGEN

Internet: [www.kollmorgen.cn](http://www.kollmorgen.cn)

E-Mail: [sales.china@kollmorgen.com](mailto:sales.china@kollmorgen.com)

Tel: +86 - 400 661 2802

Fax: +86 - 21 6128 9877



KOLLMORGEN  
CHINA Website