

AKD[®] Decentralized Drive System Project Guide

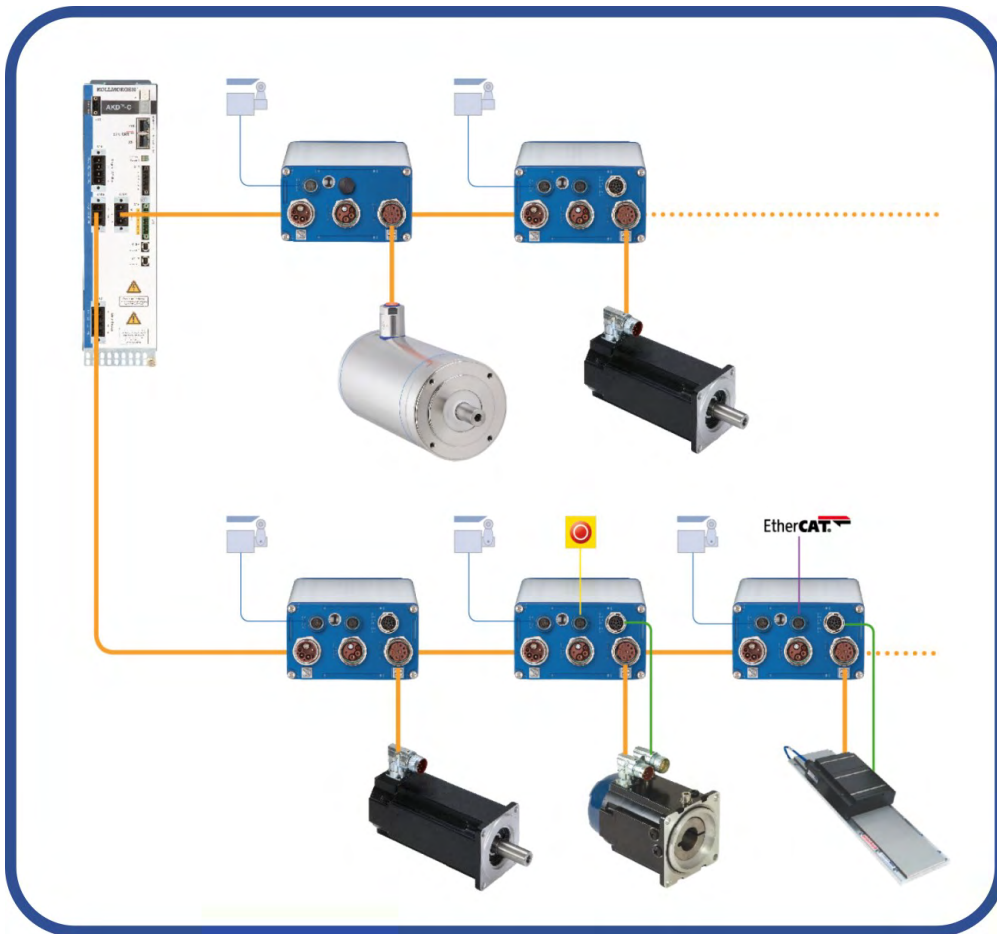

Edition: C, November 2018
Translation of the original document



For safe and proper use, follow these instructions.
Keep them for future reference.

Record of Document Revisions

Revision	Remarks
A, 12/2015	Launch version
B, 11/2016	24V supply overview drawings optimized, slip ring example added
C, 11/2018	References to motor connector option A3 removed, heat sink 40mm removed, certified slip rings, document renamed to "Project Guide", new readers note on cover page

Trademarks

- AKD is a registered trademark of Kollmorgen Corporation
- SynqNet is a registered trademark of Motion Engineering Inc.
- EnDat is a registered trademark of Dr. Johannes Heidenhain GmbH
- EtherCAT is a registered trademark and patented technology, licensed by Beckhoff Automation GmbH
- Ethernet/IP is a registered trademark of ODVA, Inc.
- Ethernet/IP Communication Stack: copyright (c) 2009, Rockwell Automation
- sercos® is a registered trademark of sercos® international e.V.
- HIPERFACE is a registered trademark of Max Stegmann GmbH
- PROFINET is a registered trademark of PROFIBUS and PROFINET International (PI)
- SIMATIC is a registered trademark of SIEMENS AG
- SpeedTec is a registered trademark of TE Connectivity Industrial GmbH
- Windows is a registered trademark of Microsoft Corporation

Current patents

- US Patent 8.154.228 (Dynamic Braking For Electric Motors)
- US Patent 8.214.063 (Auto-tune of a Control System Based on Frequency Response)
- US Patent 8.566.415 (Safe Torque Off over network wiring)

Patents referring to fieldbus functions are listed in the matching fieldbus manual.

Technical changes which improve the performance of the device may be made without prior notice!

This document is the intellectual property of Kollmorgen. All rights reserved. No part of this work may be reproduced in any form (by photocopying, microfilm or any other method) or stored, processed, copied or distributed by electronic means without the written permission of Kollmorgen.

1 Table of Contents

1	Table of Contents	3
2	General	5
2.1	About this Guide	6
2.1.1	The Advantages of Decentralized Drive Technology	6
2.2	Documentation for Decentralized Drive Systems	7
2.3	Components for Decentralized Drive Systems	8
2.3.1	Components delivered by Kollmorgen	9
2.3.2	Components to be added by the user	11
2.3.2.1	Cabinet grommets	11
2.3.2.2	M12 Data cables for AKD-N	11
2.3.2.3	Power Supply 24 VDC	11
2.3.2.4	Fuses	11
2.3.2.5	Personal Computer	11
2.3.2.6	Slip-rings	11
3	System Design Planning	13
3.1	System requirements	14
3.1.1	Requirements to the application	14
3.1.2	System limits	14
3.1.3	Requirements to the ambient conditions in operation mode	15
3.1.3.1	AKD-C	15
3.1.3.2	AKD-N	15
3.1.3.3	Prohibited Use	16
3.2	System temperature management	17
3.2.1	AKD-C installation instructions	17
3.2.2	Brake resistor installation instructions	17
3.2.3	AKD-N installation instructions	17
3.2.4	Temperature measurement in the AKD-N	18
3.2.5	AKD-N cooling plate selection	18
3.2.6	Rth calculation	19
4	System Electrical Planning	20
4.1	System Grounding	21
4.2	System 24V	23
4.2.1	Supply with centralized 24 V power supply (P1)	23
4.2.2	Supply with decentralized 24 V power supplies (P1, P2, P3)	24
4.2.3	GND definition	25
4.2.4	System power 24 V (Stand-By operation)	25
4.3	System Cabling Concept	26
4.3.1	Cable length definition	26
4.3.2	Device connection from IP54 to IP65/67 environments	27
4.4	System fusing	28
4.4.1	Mains Fusing	28
4.4.2	24 VDC fusing	29
4.4.3	Regen resistor fusing	29

5 Functional Safety	30
5.1 General	31
5.2 Global STO	32
5.3 Local STO	34
5.4 Global / Local STO combination	37
5.5 Calculation of Safety Levels for the STO function	39
5.5.1 Abbreviations	39
5.5.2 General	40
5.5.3 AKD-C and AKD-N internal structure	40
5.5.4 Safety-related features of the subsystem AKD-C and AKD-N	40
5.5.5 Essential safety considerations in accordance with EN 61800-5-2	40
5.5.5.1 Risk analysis in accordance with ISO 12100:2010	41
5.5.6 Safety-related assessment of the system according to ISO 13849-1	42
5.6 Stop / Emergency Stop / Emergency Off	43
5.6.1 Stop	43
5.6.2 Emergency Stop	44
5.6.3 Emergency Off	44

2 General

2.1 About this Guide	6
2.2 Documentation for Decentralized Drive Systems	7
2.3 Components for Decentralized Drive Systems	8

2.1 About this Guide

This guide, *Decentralized Drive System Project Guide* helps to define a Kollmorgen decentralized drive system with AKD-C and AKD-N devices.

In the Project Guide you will find:

- Overview of available components,
- Where to buy components which are not offered by Kollmorgen,
- Notes for physical and electrical requirements to the system components.

2.1.1 The Advantages of Decentralized Drive Technology

Reduced costs

- Reduced cabling because DC and fieldbus, power, I/O and safety (STO) run in one cable.
- Faster and simple assembly requires no special training through ready-made and tested cables.
- Pick the optimum motor for the machine. No derating of oversized motors as required by most integrated solutions.

More compact machines

- Smaller and more easily integrated electrical cabinets.
- Servo amplifiers mounted in the immediate vicinity of the motor.
- Robust construction with IP67 protection rating makes large protective enclosures irrelevant.

Faster commissioning

- IP67 rated connectors for connection without tools.
- At only eleven millimeters, the thin hybrid cable has a small bending radius to save space – even in cramped machine corners.
- Connect remote I/O modules and fieldbuses devices directly to the drive via the optional local EtherCAT port.
- Parameterization with the KollmorgenWorkBench.

Higher machine efficiency (OEE)

- Design supports fast and effective cleaning.
- High operating safety through robust construction.
- Precision through digital feedback.
- Everything at a glance: Status display on servo amplifier.

More flexibility in machine design

- Compatible with all Kollmorgen motors with single cable or dual cable connection.
- Simple combination of central and decentralized controllers within the comprehensive AKD family.
- Faster modification and upgrade options through linear topology as well as I/O and fieldbus interfaces at the drive.

2.2 Documentation for Decentralized Drive Systems

Several guides and manuals describe the components which can be used in a decentralized drive system. The graphics below shows the most important document names:

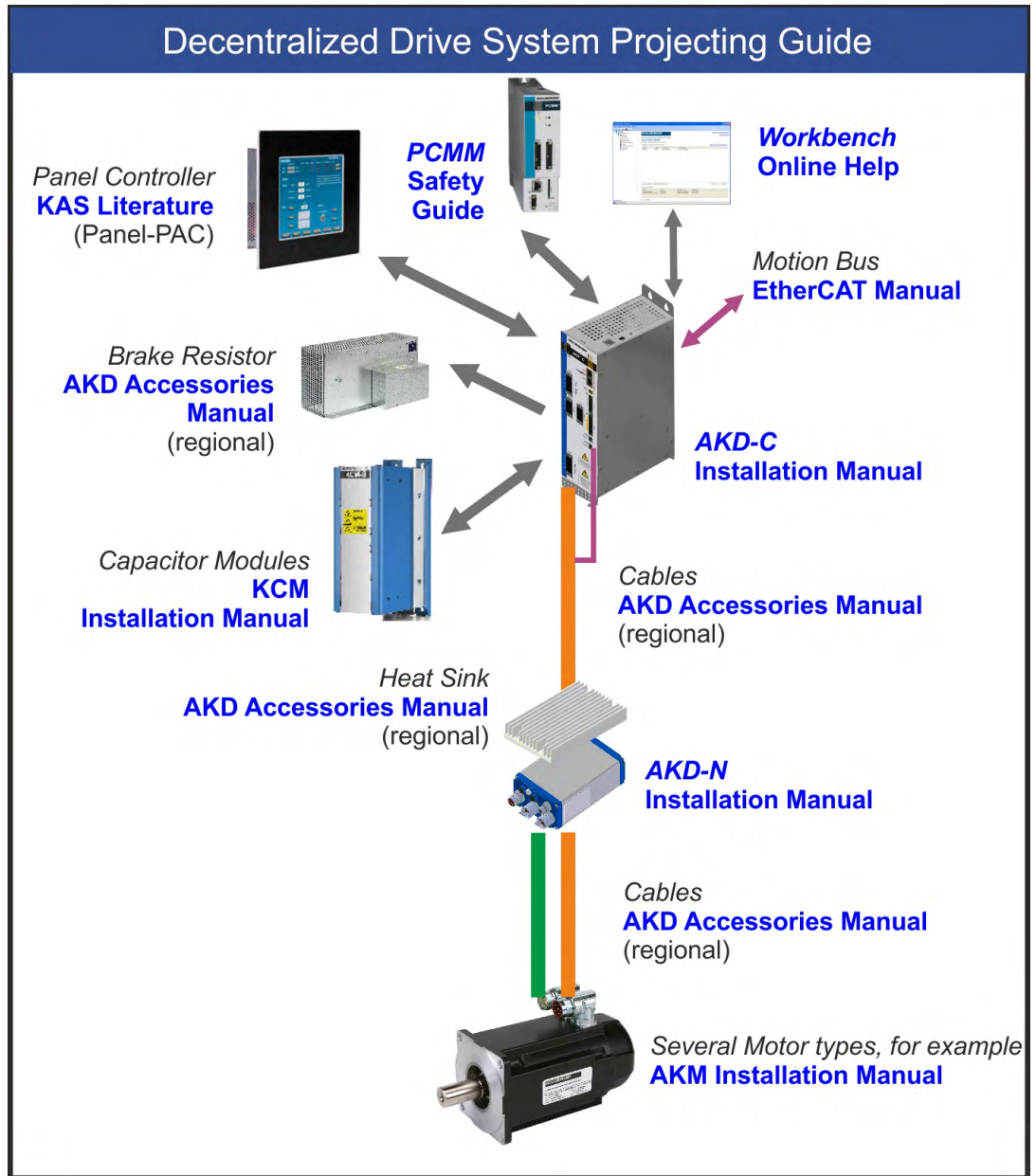

Product	Document	Languages	Location
KAS	Several	EN	KAS DVD, Website
Workbench	Online Help	EN, GE, SP, PO, CH	AKD DVD, Website
Motion Bus	Several	EN, GE	AKD DVD, Website
PCMM	Safety Guide (i.p.)	EN, GE, FR, IT, SP, PO, RU	Product, Website
AKD-C/AKD-N	Installation Manuals	EN, GE	AKD DVD, Website
Accessories	Manual (regional)	EN, GE	AKD DVD, Website
KCM	Installation Manual	EN, GE, IT, SP	Product, Website
Motor	Installation Manual	EN, several	Product, Website

2.3 Components for Decentralized Drive Systems

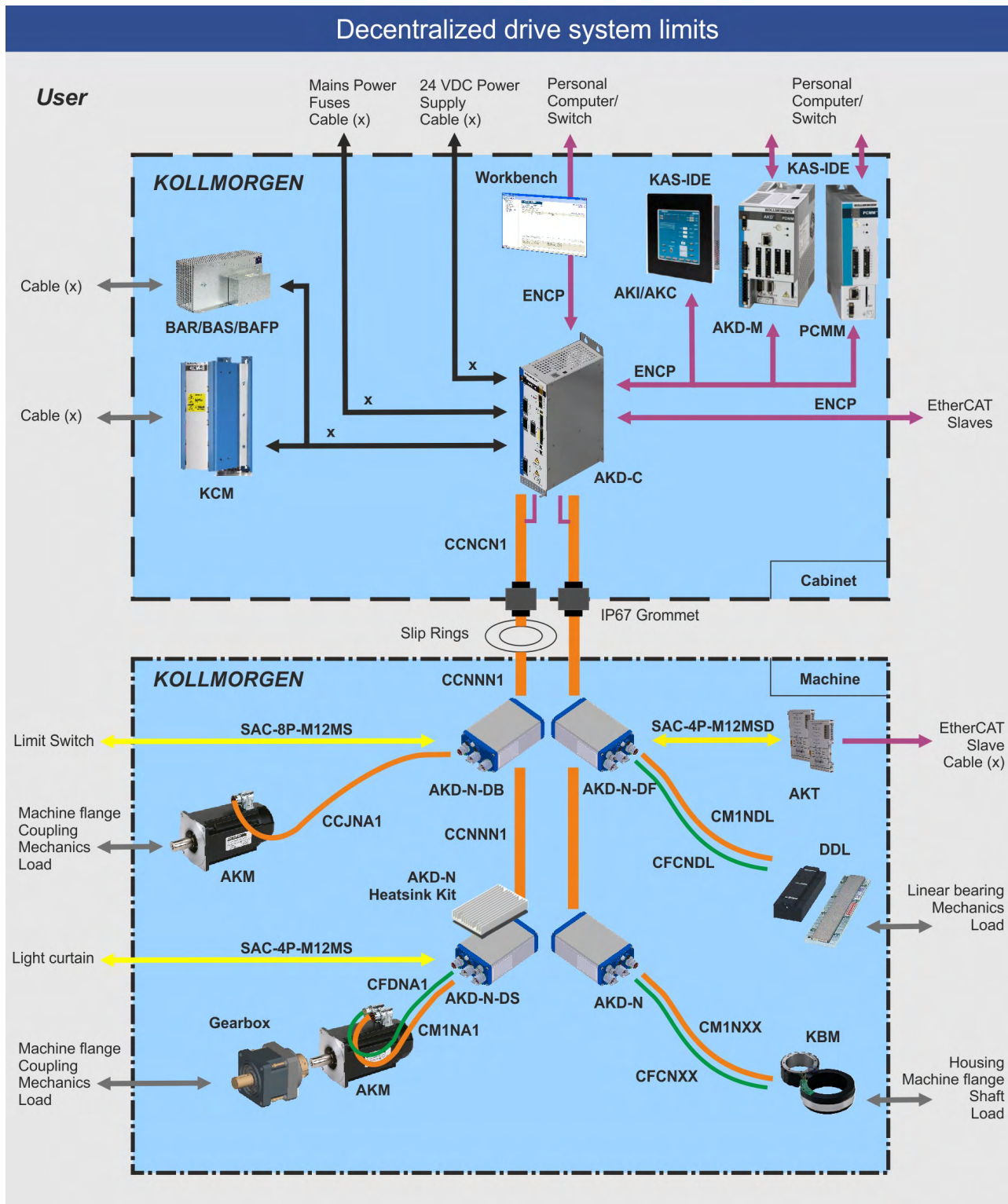

All components in the blue rectangle are products delivered by Kollmorgen. Elements in the gray area show, and the cables signed with "x" are components which have to be added by the machine builder.

2.3.1 Components delivered by Kollmorgen





Kollmorgen delivers most of the components which are necessary to build a decentralized drive system.

Motion Control	Information	Order Code
AKC-PNC	IPC with touchscreen	See part number scheme in the matching manual or catalog
AKC-PCM	PCMM Motion Controller	
PDMM (AKD-M)	Drive with Motion Controller included	
AKT	Digital I/Os	

Software	Information	Order Code
KAS IDE	Setup Software for KAS system	See part number scheme in the matching manual or catalog
WorkBench	Setup Software for drives	

Power Supply	Information	Order Code
AKD-C	10 kW, 400/480 V 20 kW, 400/480 V*	AKD-C01007-CBEC AKD-C02007-CBEC*

* = In process

Servo Drives	Information	Order Code
AKD-N-DB	Single cable motor connection 	AKD-N00307-DBEC AKD-N00607-DBEC AKD-N01207-DBEC
AKD-N-DG	Single cable motor connection, local Fieldbus 	AKD-N00307-DGEC AKD-N00607-DGEC AKD-N01207-DGEC
AKD-N-DT	Single cable motor connection, local STO 	AKD-N00307-DTEC AKD-N00607-DTEC AKD-N01207-DTEC
AKD-N-DF	Dual cable motor connection, local Fieldbus 	AKD-N00307-DFEC AKD-N00607-DFEC AKD-N01207-DFEC
AKD-N-DS	Dual cable motor connection, local STO 	AKD-N00307-DSEC AKD-N00607-DSEC AKD-N01207-DSEC

* in process

Motors	Information	Order Code
AKM	Standard servo motor	See part number scheme in the matching manual or catalog
AKMH	Stainless steel servo motor	
KBM, TBM	Kit motor for rotatory direct drives	
CDDR	Housed motor for rotatory direct drives	
IC, ICH, ICD, IL	Motor for linear direct drives	

Heat sink kits for AKD-N	Order codes
Heat sink Kit 50 mm with heat conducting film	AKD-N 3,6 HEATSINK KIT 50MM
Heat sink Kit 50 mm with heat conducting film	AKD-N 12 HEATSINK KIT 50MM
Heat conducting film AKD-N-003/006	849-373001-04
Heat conducting film AKD-N-012	849-374001-04

Capacitor Module	Information	Order Code
KCM-S200	Energy Saving Module, 1.6 kW	KCM-S200-0000
KCM-P200	Power Support Module, 2 kW	KCM-P200-0000
KCM-E200	Extension Module 2 kW	KCM-E200-0000
KCM-E400	Extension Module 4 kW	KCM-E400-0000

Regen Resistors	Information	Order Code
BAFP(U) 100-33	33 Ohms, 100 W, IP40	DE-201437
BAFP(U) 200-33	33 Ohms, 200 W, IP40	DE-201438
BAR(U) 250-33	33 Ohms, 250 W, IP20	DE-106254
BAR(U) 500-33	33 Ohms, 500 W, IP20	DE-106255
BAR(U) 1500-33	33 Ohms, 1500 W, IP20	DE-106258
BAS(U) 3000-33	33 Ohms, 3000 W, IP20	DE-201407

Cables	Information	Order Code
Hybrid Cable AKD-C ... AKD-N max. 40 m	CCNCN1	Cross reference, length definition, and order codes are listed in the regional AKD Accessories Manual.
Hybrid Cable AKD-N ... AKD-N max. 25 m	CCNNN1	
Hybrid Cable AKD-N ... Motor max. 5 m	CCJNA1 (AKM&CDDR with M23 connector) CCJNA2 (AKM with SpeedTec connector) Attention: If connected to AKD-N-DF/DS, the special connector AKD-N-JUMP-X5 must be added.	
Power Cable AKD-N ... Motor max. 5 m	CM1NA1 (AKM&CDDR with M23 connector) CM1NDL (IC/ICH/IL)	
Feedback Cable AKD-N ... Motor* max. 5 m	CFxNA1 (AKM&CDDR with M23 connector) CFxNDL (IC/ICH/IL)	
Ethernet Cable max. 100 m	ENCP	
I/O Cables max. 30 m	SAC-8P-M12MS (all AKD-N, I/O Signals) SAC-4P-M12MS (AKD-N-DS, STO Signals) SAC-4P-M12MSD (all AKD-N-DF, Bus Signals)	

* x: C=ComCoder, D=EnDat/BiSS digital, E=EnDat/BiSS, H=Hiperface, S=SFD

Jump-X5 connector for AKD-N-DS/DF with single cable connection	Order Codes
AKD-N X5 mating connector with jumper 4-5	AKD-N-JUMP-X5

2.3.2 Components to be added by the user

2.3.2.1 Cabinet grommets

The hybrid cable between AKD-C and the first AKD-N leads through the cabinet wall. To ensure IP67 protection class, Kollmorgen recommends cable entry system KDL/S combined with cable entry grommet KDT/S manufactured by Murrplastik Systemtechnik GmbH.

Please contact:

Murrplastik Systemtechnik GmbH

Fabrikstraße 10, 71570 Oppenweiler, Germany

Phone: +49 (0)7191 482-0

Website: www.murrplastik.de, E-Mail: info@murrplastik.de

2.3.2.2 M12 Data cables for AKD-N

Kollmorgen offers the cables listed below with 5 m length only:

SAC-8P-M12MS (all AKD-N, I/O signals)

SAC-4P-M12MS (AKD-N-DS, STO signals)

SAC-4P-M12MSD (all AKD-N-DF, bus signals)

More length versions can be ordered from:

Phoenix Contact Deutschland GmbH

Flachsmarktstr. 8, 32825 Blomberg, Germany

Phone: +49 (0)5235 3-12000

Website: <https://www.phoenixcontact.com>, E-Mail: info@phoenixcontact.de

2.3.2.3 Power Supply 24 VDC

Power supply requirements for 24 VDC supply see chapter "System 24V" (→ p. 23).

2.3.2.4 Fuses

Requirements for fuses for mains supply, 24V supply, and regen resistors see chapter "System fusing" (→ p. 28).

2.3.2.5 Personal Computer

The Service interface (RJ45) of the AKD-C is connected to the Ethernet interface of the PC by an Ethernet cable.

Minimum requirements for the PC:

Processor: at least 1 GHz

Operating system : Windows

Graphics adapter : Windows compatible, color

RAM: 500 MB

Data Drives : hard disk with at least 500 MB free space, DVD drive

Interface : one free Ethernet Interface, or a Switch port, 100 Mbit/s

2.3.2.6 Slip-rings

If AKD-N must be mounted on a rotary table, it is necessary to use slip-ring assemblies for energy and data transfer between AKD-C in the cabinet and AKD-N on the rotary table. Kollmorgen cooperates with company STEMMANN-TECHNIK for user specific slip-ring assembly solutions. The Safety Function STO has been tested with STEMMANN slip rings 6263576 and 6263577. These slip rings can be used as stand-alone modules or in a slip ring cassette. Please contact:

STEMMANN-TECHNIK GmbH

Niedersachsenstraße 2, 48465 Schüttorf, Germany

Phone: +49 (0)592381-0,

Website: www.stemmann.com, E-Mail: sales@stemmann.de

Application Example with slip rings (according to EN 13849)

Slip-ring carriers for the power supply and data transfer are used in all applications, where a stationary power connection is not possible on account of the rotating movement, as for example with rotary tables:

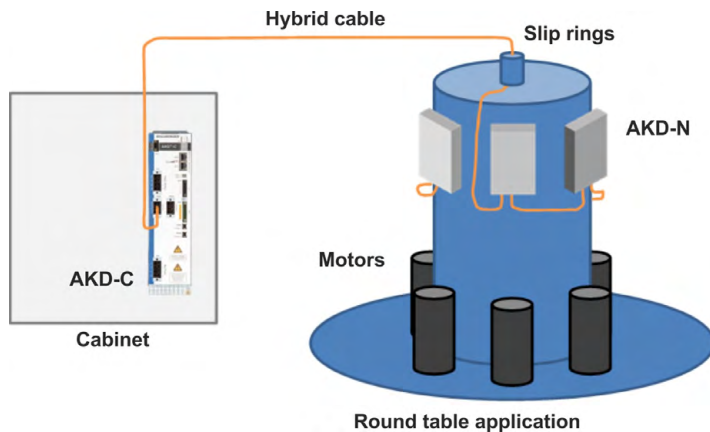

The image features a slip-ring application with four handling axes, mounted on a rotary table.

The rotary table is powered by a direct drive. The AKD-C smart power supply is located in a remote control cabinet.



The AKD-C is connected to the orange connection point via a CCNCN1 hybrid cable (max length 40m).

Besides the DC intermediate circuit with PE, the internal field bus, 24 VDC and STO are looped back into the AKD-N via the slip-ring.

Digital I/O signals travel through the black cable from the AKD-N to the PLC in the control cabinet and back again.



When using a slip-ring, all threshold values (cable lengths, thickness, etc.) are maintained as listed the operating instructions.

For any technical information and specifications regarding the slip-rings, for example operating temperature ranges, please refer to the manufacturer's manual (STEMMANN-TECHNIK). The slip-ring used here is manufactured with suitable Kollmorgen connectors. No adaptors are required, ensuring a smooth installation.

3 System Design Planning

3.1 System requirements	14
3.2 System temperature management	17

3.1 System requirements

3.1.1 Requirements to the application

Check the chapter "Use as Directed" in the installation manual of the component. Physical system requirements and limits are represented by the maximum cable length between the components.

3.1.2 System limits

AKD-C offers two strings with the ability to drive up to 8 AKD-N with each of them. Maximum distances (cable lengths) between the system components are defined:

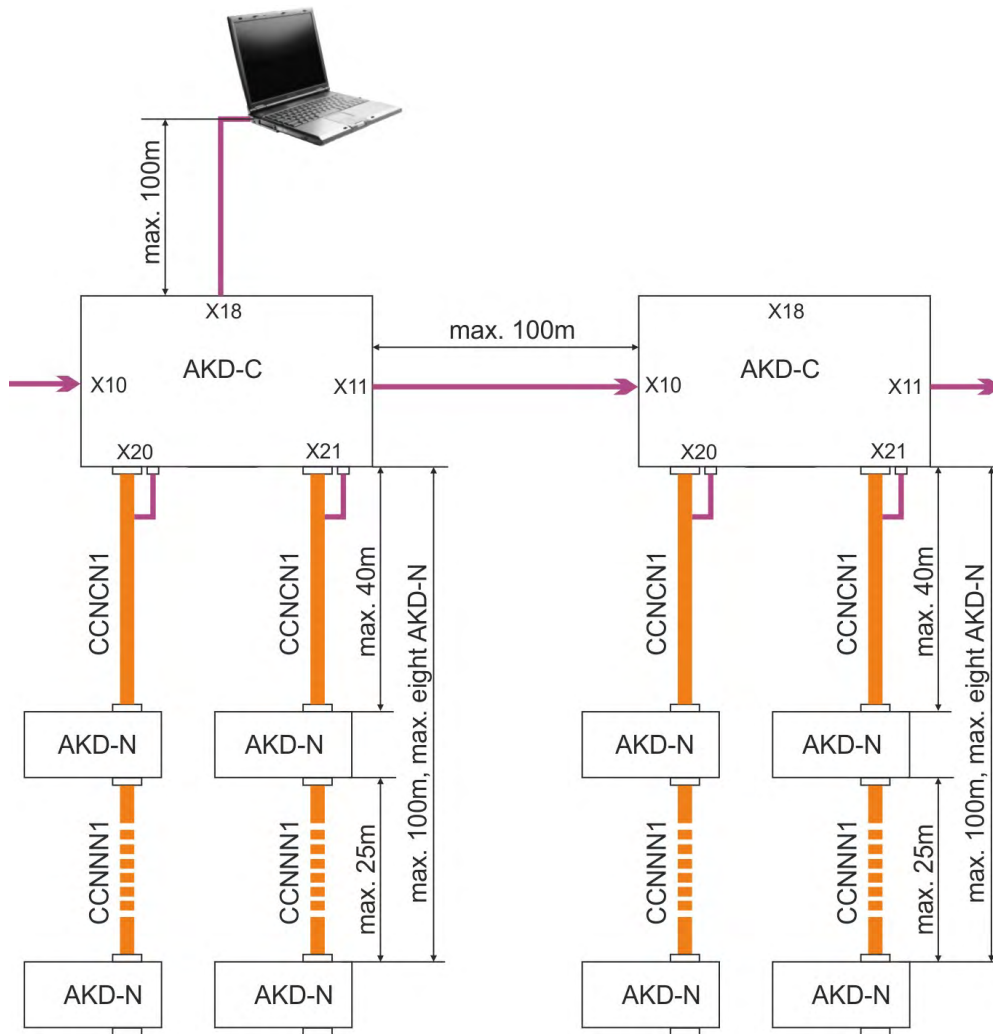

NOTICE Maximum cable length between AKD-N and motor is 5 m..

3.1.3 Requirements to the ambient conditions in operation mode

Ambient conditions in operation for AKD-C and AKD-N must be considered separately due to the different mounting environments (cabinet respectively machine).

3.1.3.1 AKD-C

In accordance with regulations, the AKD-C is installed in an IP54 control cabinet.

The permitted contamination level in the control cabinet equates to contamination level 2 in accordance with EN 60664-1. In accordance with EN 60721-3-3, you must ensure that vibrations can occur at a maximum of class 3M1.

Temperature and air humidity

The power supply unit can be used in a temperature range of between 0° C to 40°C under nominal conditions. Above this temperature derating (reducing the continuous current) by 4% per head must be performed. At 55° C the maximum ambient temperature for the AKD-C is reached.

The permitted relative humidity in the control cabinet is 5 to 85% and must not be condensing. This equates to class 3K3.

Operating altitude

The device may be operated without restrictions up to an operating altitude of 1,000 m above sea level. There is a reduction in power of 1.5% for every 100 m above an operating altitude of 1,000 m up to a maximum limit of 2,000 m above sea level. Example:

- Site altitude: up to 1000 m -> no current reduction
- 1500 m -> current reduction = $(1500 \text{ m} - 1000 \text{ m}) * 1.5\% / 100 \text{ m} = 7.5\%$
- 2000 m -> current reduction = $(2000 \text{ m} - 1000 \text{ m}) * 1.5\% / 100 \text{ m} = 15\%$
- 2500 m -> maximum altitude exceeded => operation not possible

3.1.3.2 AKD-N

In accordance with regulations, the AKD-N can be installed on the machine outside the control cabinet.

The permitted contamination level in the area of use equates to contamination level 3 in accordance with standard EN 60664-1. In accordance with EN 60721-3-3, you must ensure that vibrations occur at a maximum of class 3M5.

The IP protection class is IP65/IP67 in accordance with EN 60529, UL type 4x.

Temperature and air humidity

The AKD-N can be used in a temperature range of between -100° C to 40°C under nominal conditions. Above this temperature derating (reducing the continuous current) by 4% per head must be performed. At 55° C the maximum ambient temperature for the AKD-N is reached.

The permitted relative humidity in the control cabinet is 5 to 95% and must not be condensing. This equates to class 3K4.

Operating altitude

The device may be operated without restrictions up to an operating altitude of 1,000 m above sea level. There is a reduction in power of 1.5% for every 100 m above an operating altitude of 1,000 m up to a maximum limit of 2,000 m above sea level. Example:

- Site altitude: up to 1000 m -> no current reduction
- 1500 m -> current reduction = $(1500 \text{ m} - 1000 \text{ m}) * 1.5\% / 100 \text{ m} = 7.5\%$
- 2000 m -> current reduction = $(2000 \text{ m} - 1000 \text{ m}) * 1.5\% / 100 \text{ m} = 15\%$
- 2500 m -> maximum altitude exceeded => operation not possible

3.1.3.3 Prohibited Use

Other use than that described in chapter “Use as directed” is not intended and can lead to personnel injuries and equipment damage.

The device may not be used

- with a machine that does not comply with appropriate national directives or standards,
- for driving elevators,
- in applications with continuous, operational short circuits to the external regen resistor contacts.
- in applications with any short circuits to the DC-Bus link contacts.

The use of the device in the following environments is also prohibited:

- potentially explosive areas
- environments with corrosive and/or electrically conductive acids, alkaline solutions, oils, vapors, dusts
- ships or offshore applications

Wiring the system with hybrid cables from other manufacturers than Kollmorgen is not allowed. Changing Kollmorgen cables or connectors is not allowed.

3.2 System temperature management

3.2.1 AKD-C installation instructions

Install the AKD-C in the control cabinet as described in the installation example in the operating instructions.

Ensure adequate space for ventilation above and below the AKD-C. If the internal brake resistor is used, waste heat through the AKD-C is significantly greater than when using an external brake resistor. In particular, therefore, ensure sufficient distance to the components installed above the AKD-C (55 mm to 100 mm).

To reduce the generated brake power, a DC-Bus link coupling to an AKD-B/P/T/M or another AKD-C may be useful. This is only successful, however, if the load cycles of the adjacent drive are running in the opposite direction (no simultaneous generation operation).

If generated brake power is near to or slightly over the threshold of 100 watt, a DC-Bus link coupling to other drives can help to save on an external brake resistor.

With highly dynamic processes, it can be checked whether a capacity module can temporarily store the regeneration energy so that it can be used in the next instance of acceleration. This can reduce energy costs over the system's service life. In addition, less power loss arises in the control cabinet.

3.2.2 Brake resistor installation instructions

External brake resistors should be installed outside the control cabinet or thermally disconnected inside the control cabinet.

Due to strong thermal development, you must observe the safety distances to adjacent, flammable objects (refer to the drawing of the brake resistor in the accessories manual).

3.2.3 AKD-N installation instructions

Install the AKD-N as specified in the manual. For selecting the required cooling surface, the average capacity of the drive is relevant.

Here, 100% capacity means continuous load with rated current. 50% capacity can mean, for example

- Cycle operation: 50% activation time with rated current / 50% recovery time, or
- 100% activation time with half of rated current.

Installation on any metallic surface will suffice at an average capacity of 50% (for AKD-N 3A and 6A).

The cooling surfaces (aluminum) stated in the operating instructions of

- 240 x 240 x 10 mm for AKD-N 3A and
- 500 x 500 x 10 mm for AKD-N 6A,

enable 100% capacity for operation on a 480 V grid and 40°C ambient temperature.

3.2.4 Temperature measurement in the AKD-N

The AKD-N has two internal temperature sensors: one is connected to the control card, the other with the power semiconductors. The sensor values can be queried using the command *drv.temperature*.

- Control card temperature: warning 90°C / shutdown 95°C
- Power temperature: warning 90°C / shutdown 95°C

NOTICE

If the 'Power' temperature does not exceed 85°C during operation of the machine, the cooling plan is OK.

Please be advised that it may take several hours before the temperature reaches the thermal steady state.

Examples:

- AKD-N 3A in the air is stable after 60 minutes
- AKD-N 6A on cooling plate 500x500x10 mm is stable after 180 minutes

3.2.5 AKD-N cooling plate selection

An ideal cooling situation is a requirement for operating an AKD-N at maximum power in the machine.

You will find a few examples below to help estimate the thermal resistance (R_{th}) of an installation geometry.

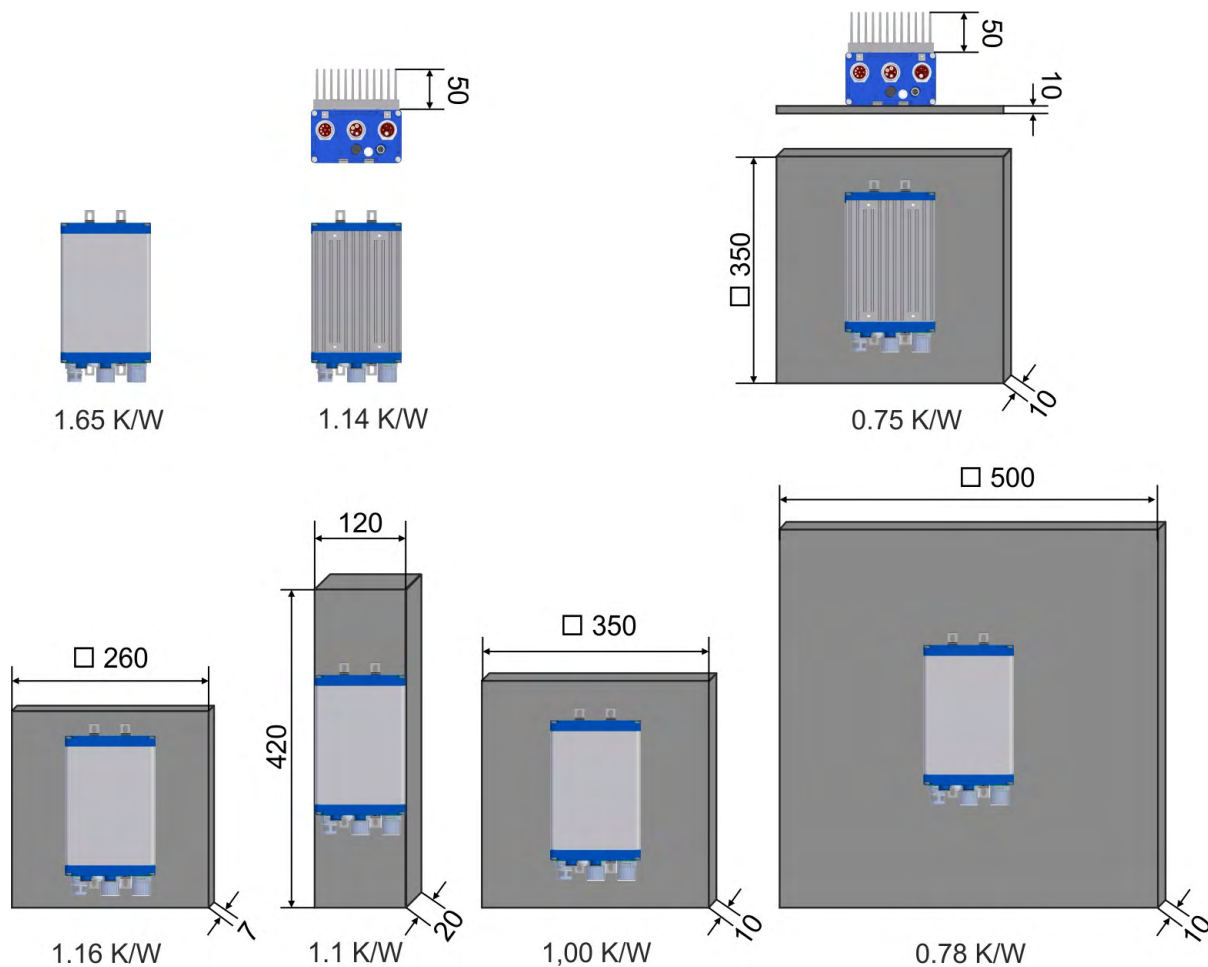

3.2.6 Rth calculation

Thermal resistance (Rth) (unit K/W) is a thermal parameter and a measure for the temperature difference that arises in a body when a thermal current permeates it.

NOTICE

In order to deduce the resulting loss of power, the Rth of a system geometry must not exceed a particular value.

To calculate the permitted maximum Rth, you require the AKD-N power loss (P). The power loss depends on

- The intermediate circuit voltage (determined by the mains voltage) and
- The average output current (determined by the average load torque):

I [A]	AKD-N 3A		AKD-N 6A	
	400V Mains (565 VDC)	480 V Mains (680 VDC)	400V Mains (565 VDC)	480 V Mains (680 VDC)
	P [W]	P [W]	P [W]	P [W]
0.00	9.8	11.4	10.1	11.8
1.00	16.6	16.9	16.9	17.2
2.00	26.2	27.0	26.3	27.1
3.00	35.2	37.5	36.4	38.7
4.00	-	-	44.9	47.8
5.00	-	-	55.1	58.7
6.00	-	-	67.3	71.6

Rth calculation example:

An ambient temperature of 40°C results in a max. permitted temperature difference (dT) of 50K based on the warning temperature in the power module (90°C).

This equates to a maximum permissible Rth of 1.11 K/W for an AKD-N-6A with 4A continuous load on a 400 V mains:

$$R_{th} = dT / P$$

$$R_{th} = 50 \text{ K} / 44.9 \text{ W} = 1.11 \text{ K/W}$$

Result:

From the example geometries (→ p. 18) you can see, for example, that a 350x350x10 mm square cooling plate (Rth ~ 1.00 K/W) suffices for cooling.

4 System Electrical Planning

4.1 System Grounding	21
4.2 System 24V	23
4.3 System Cabling Concept	26
4.4 System fusing	28

4.1 System Grounding

Ensure the proper grounding of all components with the PE rail in the control cabinet as reference potential. Connect each ground individually with the intended grounding cable (neutral point connection).

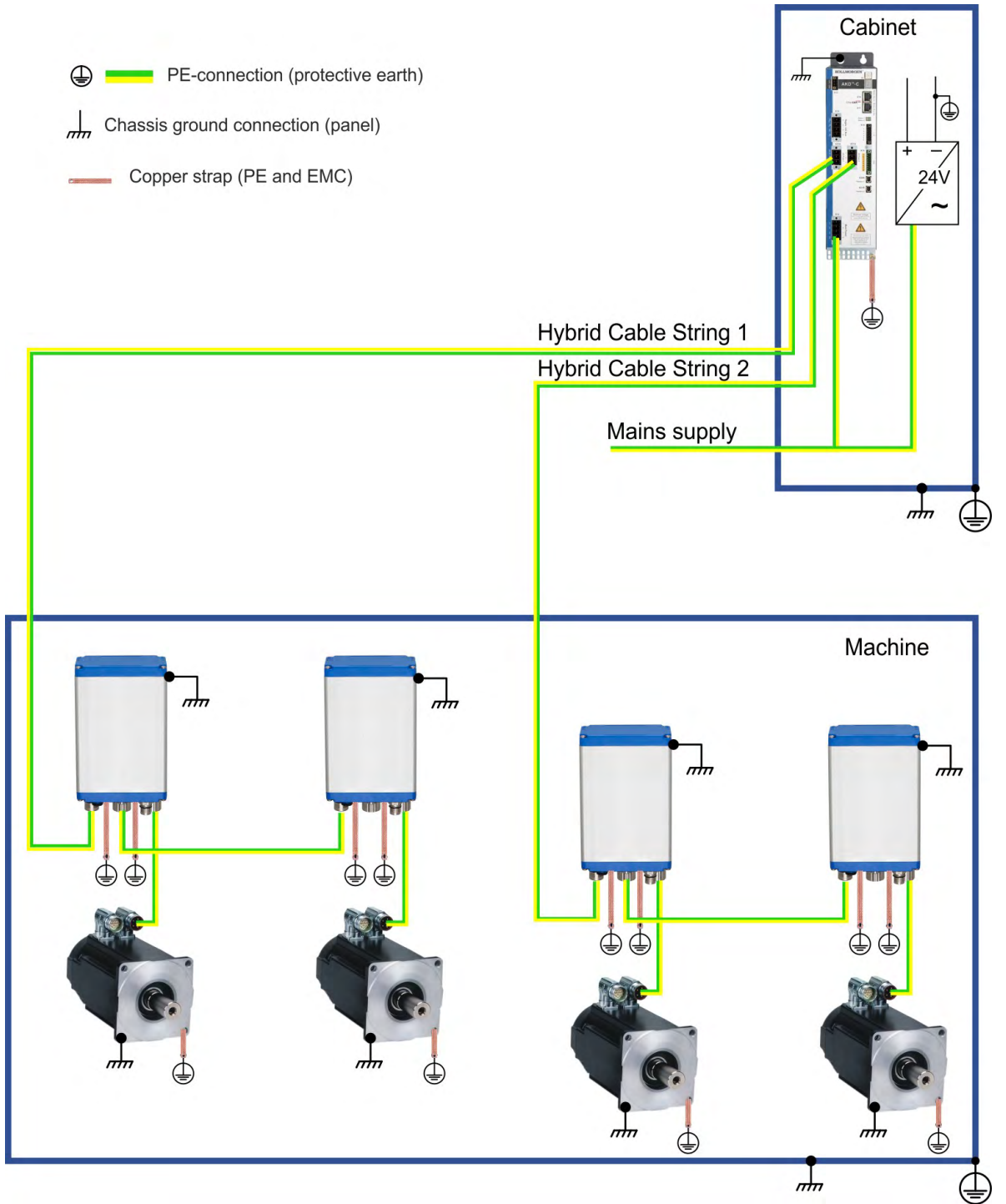

Protective Earth (PE)

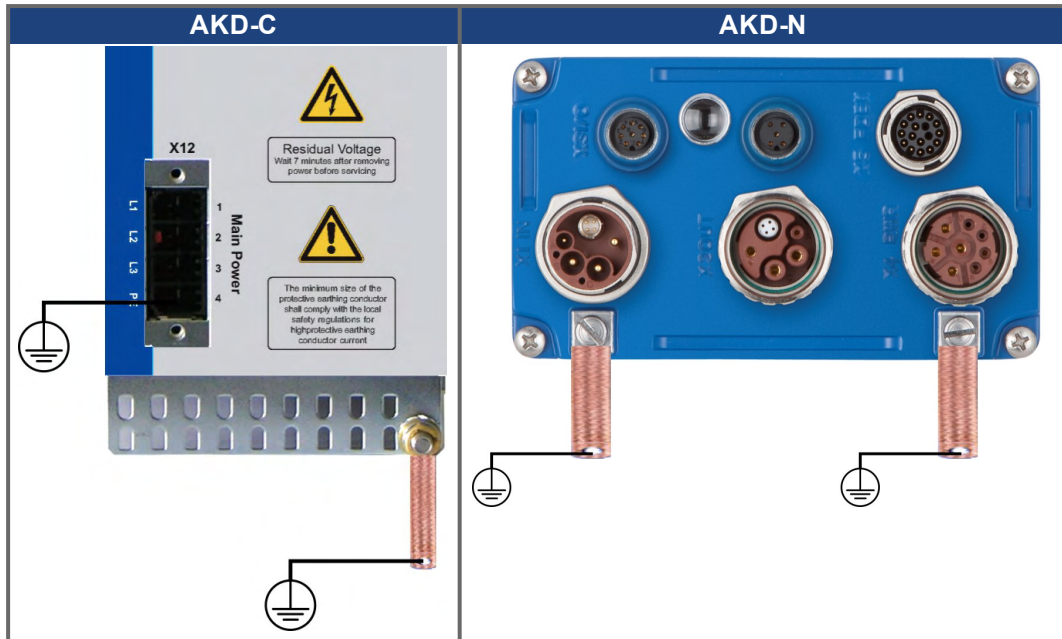

The leakage current against PE is more than 3.5 mA. In accordance with EN 61800-5-1, the PE connection must therefore either be double implemented or a connection cable with $>10\text{mm}^2$ cross-section used.

NOTICE

Wire the PE connections immediately after installing the devices as the first electrical connection. Only after that may you insert all the other plug connectors. For disassembly, release the PE connections as the last connection.

AKD-C

Use the PE terminal (X12) and the PE pin. The double connection is thus ensured. In order to keep the impedance as low as possible, we recommend a copper earthing strap for the PE connection on the PE pin.

AKD-N

Use both PE connections. To keep impedance as low as possible, we recommend copper earthing straps for the PE connections.

4.2 System 24V

The decentralized concept of a drive system with AKD-C and AKD-N may lead to large cable lengths and the voltage drops on the cable associated with this or to interfering signals (impedance coupling). Depending on the situation in your application, choose a centralized or decentralized supply, or a combination of the two concepts.

4.2.1 Supply with centralized 24 V power supply (P1)

NOTICE

Power supply unit P0 (PELV) supplies the safety control and must meet the requirements of the safety circuit. We recommend using a separate power supply unit here. Power supply unit PS1 must be able to deliver inrush current and continuous current for the entire system. A central power supply unit for supplying components in the control cabinet and in the machine should only be used for short distances (short cables).

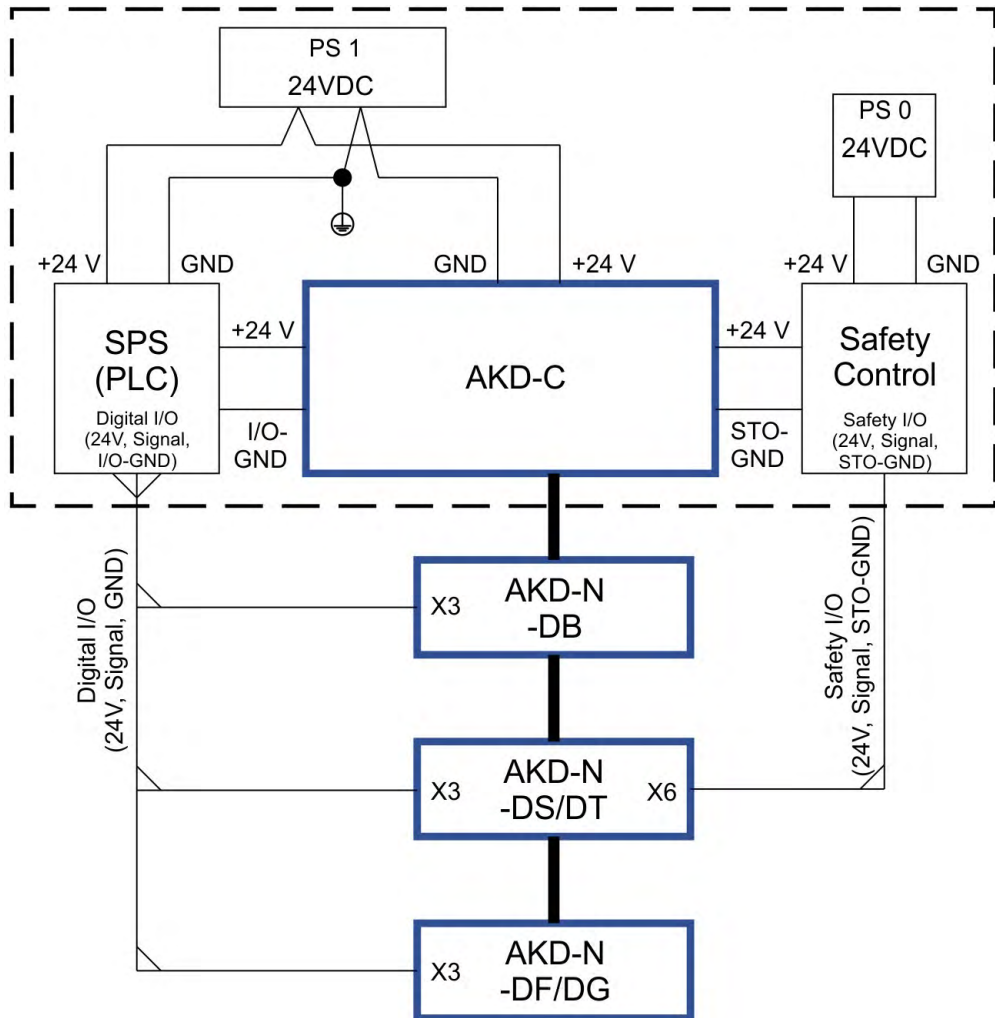

Requirements for 24 V power supplies

#	Supply for	Tolerance	Continuous Current*	Inrush Current*	Protection class	Remarks
PS0	Safety Control	+/- 10%	> 5A	> 5A	IP20	PELV/SELV
PS1	AKD-C, SPS (PLC), sensors	+/- 10%	> 14A	> 16A	IP20	Galvanically isolated (isolating transformer or similar)

* Current for AKD-C with maximum fill rate (see "System power 24 V (Stand-By operation)" (→ p. 25)). Add current for PLC and for the used sensors.

4.2.2 Supply with decentralized 24 V power supplies (P1, P2, P3)

NOTICE Power supply unit P0 (PELV) supplies the safety control and must meet the requirements of the safety circuit.
 Power supply unit PS1 must be able to deliver inrush current and continuous current for the entire system.
 Power supply unit P2 supplies the PLC and must meet the requirements of the PLC.
 Power supply unit P3 supplies the limit switches and sensors in the machine, for example, and must meet the requirements of the environment.

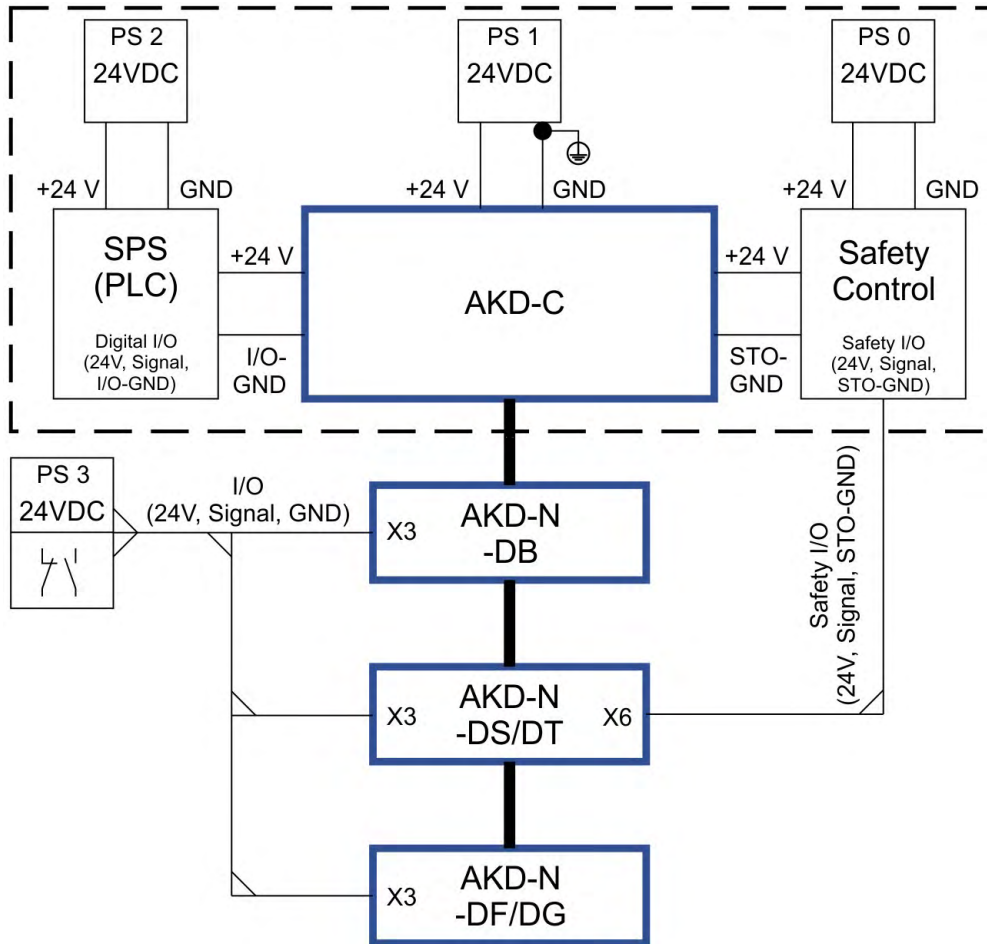

Requirements for 24 V power supplies

#	Supply for	Tolerance	Continuous Current*	Inrush Current*	Protection class	Remarks
PS0	Safety Control	+/- 10%	> 5A	> 5A	IP20	PELV/SELV
PS1	AKD-C	+/- 10%	14 A	16 A	IP20	Galvanically isolated (isolating transformer or similar)
PS2	SPS (PLC)	+/- 10%	depends on system		IP20	
PS3	Sensors	+/- 10%	depends on system		IP67	

* Current for AKD-C with maximum fill rate (see "System power 24 V (Stand-By operation)" (→ p. 25)).

4.2.3 GND definition

AKD-C	I/O-GND	Common line for digital inputs X15	X15/4
	GND	24 V supply	X13/2
	STO-GND	STO input (global)	X16/4-5-7
AKD-N	I/O-GND	Common line for digital inputs X3	X3/6
	STO-GND	STO input (local, AKD-N-DS/DT)	X6/2

All GND networks are galvanically isolated from each other. Ground loops can be prevented in this way. The GND on the 24V power supply unit (PS1) should be grounded.

4.2.4 System power 24 V (Stand-By operation)

If no mains voltage is connected to the AKD-C or activated, the 24V power supply unit (PS1 in the examples) supplies standby power. The 24 VDC voltage which is then supplied is converted into a 55 VDC intermediate circuit voltage in the AKD-C, with the help of which the AKD-N can lead the drive to a secure state (e.g. emergency braking).

Example combination:

AKD-C Strings	AKD-N	Stand-By Current PS1 (without I _{brake})	Max. Current AKD-C	Possible Brake Current
0	0	0,48 A	14 A	-
1	1	2,50 A	14 A	11,50 A
1	2	2,80 A	14 A	11,20 A
1	4	3,40 A	14 A	10,60 A
1	8	4,60 A	14 A	9,40 A
2	2	2,80 A	14 A	11,20 A
2	4	3,40 A	14 A	10,60 A
2	8	4,60 A	14 A	9,40 A
2	16	7,00 A	14 A	7,00 A

The sum of AKD-N stand-by supply current and motor brake current *I_{brake}* for every used 24 V motor brake must not exceed 14 A.

Motor Brake Current ($\pm 7\%$) with AKM motors:

Motor	AKM1	AKM2	AKM3	AKM4	AKM5	AKM6	AKM7	AKM8
I_{brake}	0,27 A	0,35 A	0,42 A	0,53 A	0,81 A	1,07 A	1,48 A	2,1 A

4.3 System Cabling Concept

4.3.1 Cable length definition

AKD-C offers two strings with the ability to drive up to 8 AKD-N with each of them.
 Maximum cable length for each string is 100 m.

Cable type	Cable usage	Max. Length (m)
CCNCN1	X20/X21, AKD-C to AKD-N, hybrid	40
CCNNN1	AKD-N to AKD-N, hybrid	25
CCJNA*	AKD-N to Motor, hybrid	5
CMxNA*	AKD-N to Motor, power	5
CFyNA*	AKD-N to Motor, feedback	5
Ethernet cable	X10/X11, AKD-C to AKD-C	100
Ethernet cable	X10/X11, AKD-C to PC/Switch	100
Single line	X13 +24 V/GND, X15 Digital I/Os, X16 STO signals	30

Maximum cable lengths between the decentralized system components

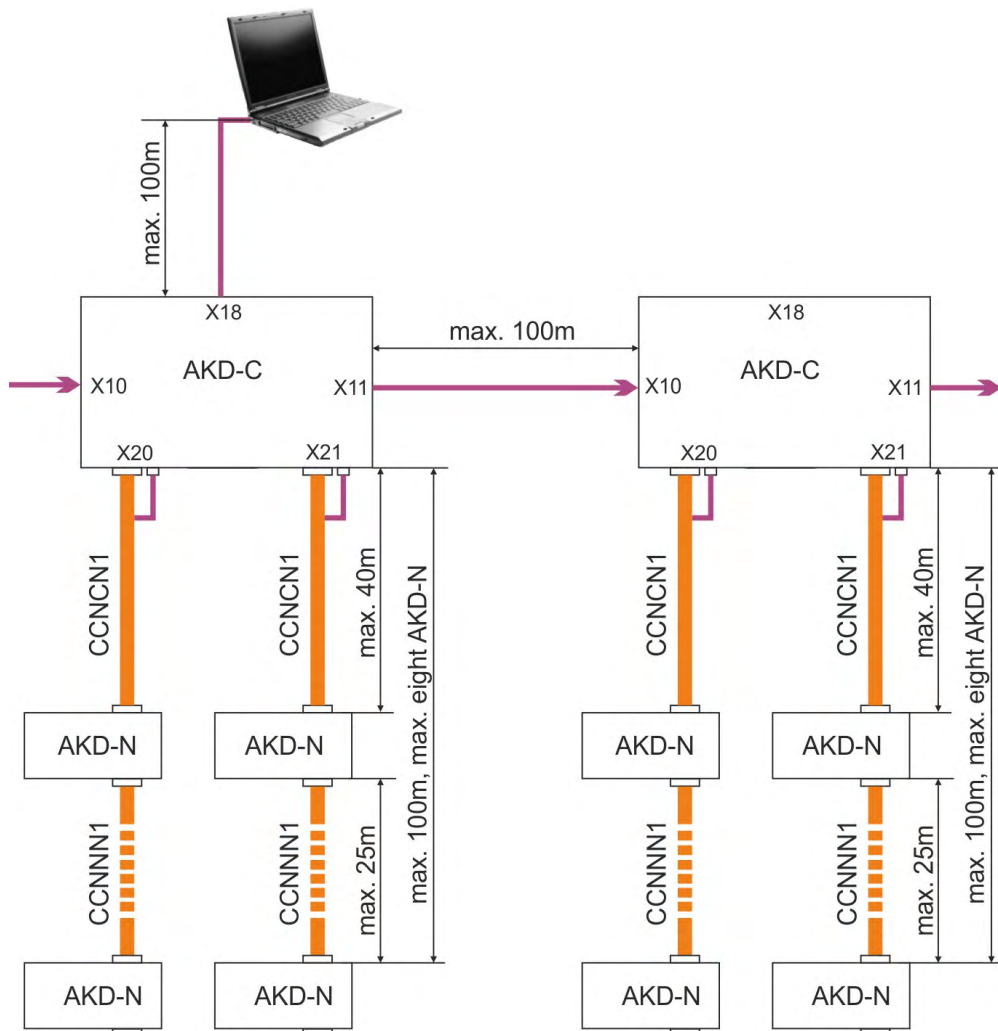

Maximum cable length between AKD-N and motor

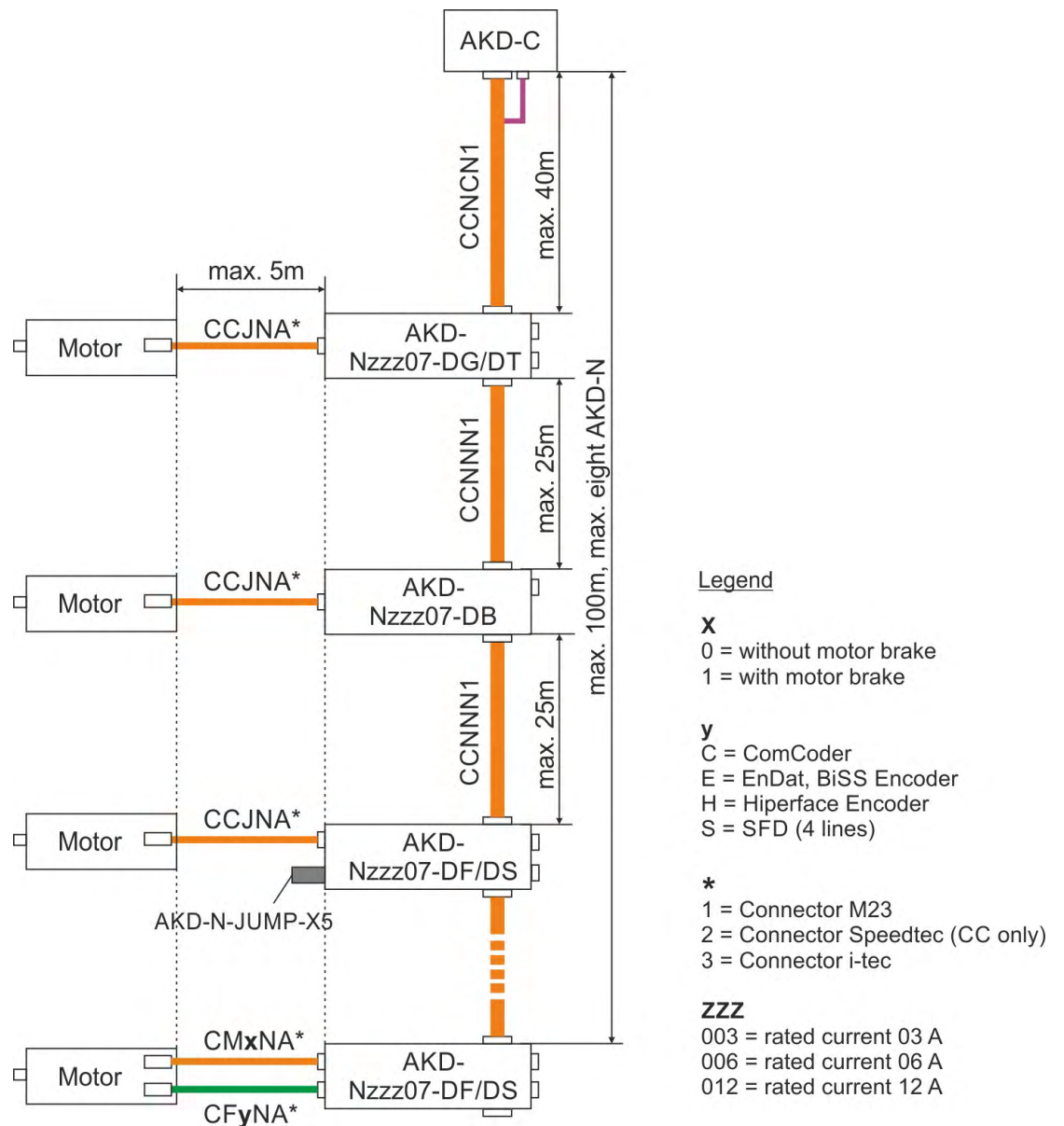

4.3.2 Device connection from IP54 to IP65/67 environments

The hybrid cables between AKD-C and AKD-N must be led out of the (IP54) cabinet.



Usable cabinet grommets and a suggested source can be found in chapter "Cabinet grommets" (→ p. 11).

4.4 System fusing

4.4.1 Mains Fusing

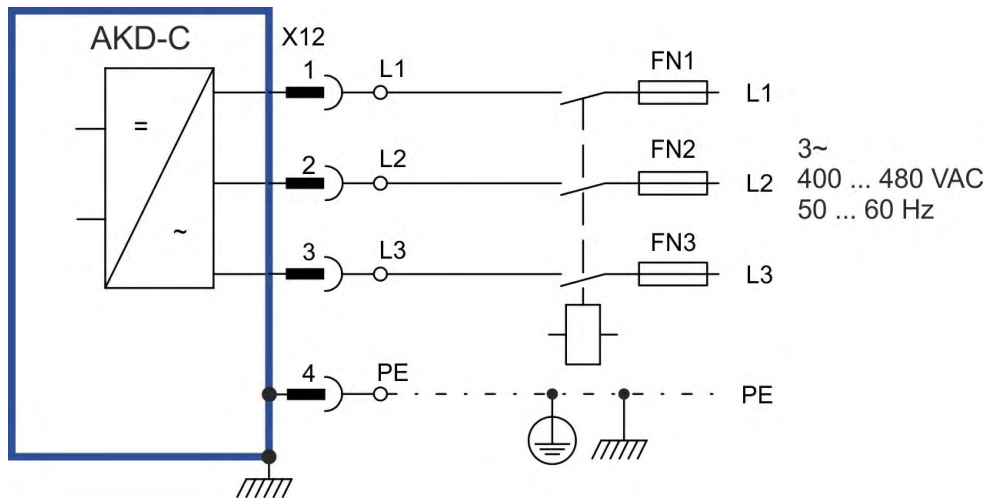

Operation in CE regions

In Europe you must use fuses of the standardized classes gS (device and line protection) or gG (general protection) according to the supply voltage with voltage ratings of 400 VAC or 500 VAC.

- Fuse class gS, gG
- Voltage rating 500VAC
- Interrupting rating 200kArms
- Ampere rating 20A (time-delay)
- Example (SIBA): 20A gRL(gS) 600VAC/200kA 10x38mm

Example finger safe fuse holder according to IEC 60529:

Siba: ZS-Module, fuse size 10x38mm, 0 to 30A, 3 poles: 51 063 04.3

Operation in UL-cUL regions

Fusibles cut-out:

You must use fuse classes RK5, CC, J or T with a 600VAC voltage rating and 200kArms interrupting rating. The fuse must be UL and CSA listed, UR recognized is not sufficient.

- Fuse class RK5, CC, J, T
- Voltage rating 600VAC
- Interrupting rating 200kArms
- Ampere rating 20A (time-delay)
- Example (Cooper Bussmann): LPJ20SP oder DFJ20

Example finger safe fuse holder according to IEC 60529:

Bussmann, CH Series Modular Fuse Holders, fuse size 0 to 30A class J, 3 poles: CH30J3

Automatic Circuit Brakers:

Approved automatic Circuit Breaker UL 489, CSA C22.2 No.5,

- Fuse class CB
- Voltage rating 480Y/277 VAC
- Ampere rating 20A
- Interrupting rating 65 kA
- Example (Siemens): 3RV1742-5CD10

4.4.2 24 VDC fusing

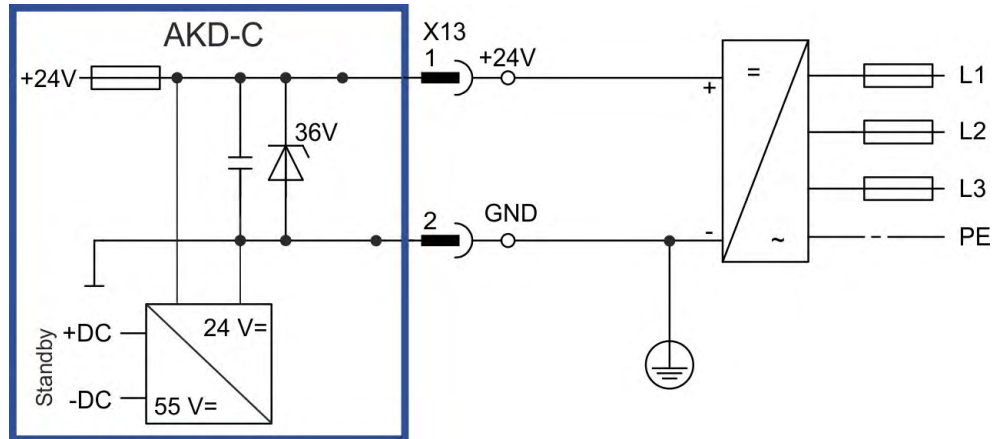

The 24V supply input of the AKD-C is short circuit-proof. Secure the 24 V power supply units used in accordance with the supply line cross-sections used.

The relationship between routing type, ambient conditions, cable cross-section and current for Europe is described in EN 60204.

4.4.3 Regen resistor fusing

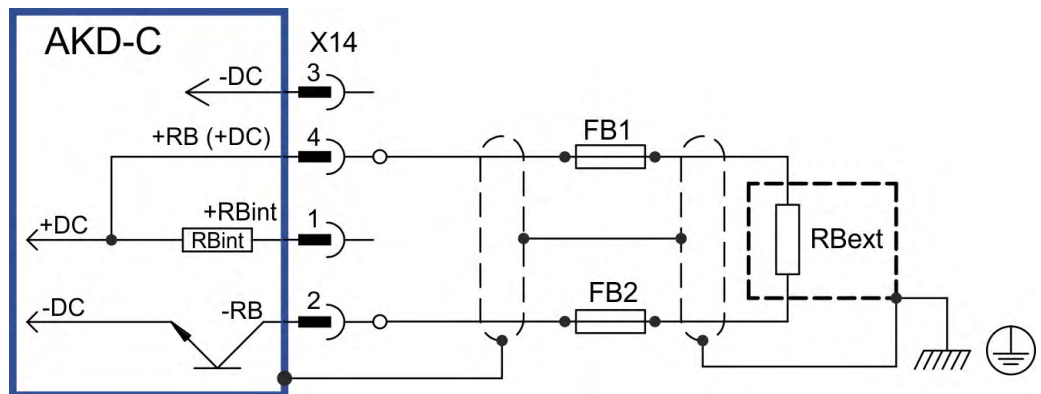

The fuses do not protect the brake resistor from thermal overload. this supervision is done by the amplifier's software, if the parameterizing is correct. The fuses shall protect from short circuit and earth short circuit!

Operation in CE regions

- Fuse class aR
- Voltage rating 700VDC
- Interrupting rating 30kArms
- Ampere rating 25A
- Example (Siba): aR, 25A

Fuse holder 2 poles (Siba) : model „finger-save“, 14x51mm, Part.-No: 51 058 04.2

Operation in UL-cUL regions

- Fuse class 800VDC
- Ampere rating 25A
- Example (Cooper Bussmann): FWP-25A14F

Fuse holder 3 poles : Cartridge Fuse Holders CH series, size 14x51mm, class J, CH14J3

5 Functional Safety

5.1 General	31
5.2 Global STO	32
5.3 Local STO	34
5.4 Global / Local STO combination	37
5.5 Calculation of Safety Levels for the STO function	39
5.6 Stop / Emergency Stop / Emergency Off	43

5.1 General

With the decentralized servo drive system AKD-C/N, the safe motion function 'Safe Torque Off' is implemented in two different versions:

- 'Global STO' for safe shutdown of the torque of all drive axes and
- 'Local STO' for the safe shutdown of the torque of one drive axis.

Global STO (AKD-C)

String (1/2) STO-Enable	String (1/2) HW Enable	String / (1/2) STO-Status	Safety acc. to SIL2	AKD-N in the string can produce torque
0 V	no	High	yes	no
0 V	yes	High	yes	no
+24 V	no	Low	no	no
+24 V	yes	Low	no	yes

Local STO (AKD-N-DS/DT)

Local STO-Enable	String HW Enable	Local STO-Status	Safety acc. to SIL2	AKD-N-DS/DT can produce torque
0 V	no	High	yes	no
0 V	yes	High	yes	no
+24 V	no	Low	no	no
+24 V	yes	Low	no	yes

Due to the high degree of flexibility of the system, both modular solutions per drive string and combinations from both versions can be implemented.

The following considerations are made purely from a safety perspective. The influence of HW-Enable and SW-Enable on the 'torque enable' remains unconsidered. Additionally, it is required that the entire system is ready for operation. All connections have been correctly established and checked. Mains power is available and so on.

Used colors in the examples:

Red	<ul style="list-style-type: none"> • Torque is released, activated • Unsafe status (no functional safety) • STO-Enable +24Vdc
Green	<ul style="list-style-type: none"> • Torque is locked safely, deactivated • Safe status (functional safety) • STO-Enable 0Vdc
Yellow	<ul style="list-style-type: none"> • Signal STO-Status probably HIGH • AKD-C STO-Status influenced by various events • Unsafe signal status or output
Orange	<ul style="list-style-type: none"> • Controlled stop activated via digital input • Drive stops with set brake ramp • Torque is switched on

5.2 Global STO

The AKD-C has two safe STO inputs (STO-Enable 1/STO-Enable 2) with which the torque from all connected drives can be safely switched off either globally or in a quasi modular basis for each drive string.

The inputs must be controlled through a safety relay or a safety controller.

In addition, there are another 2 non-safe status outputs (STO-Status 1/ STO-Status 2) available, which amongst other things: Provide information on the status of the STO function.

The outputs can be evaluated in a PLC.

Example: Global STO for all drives

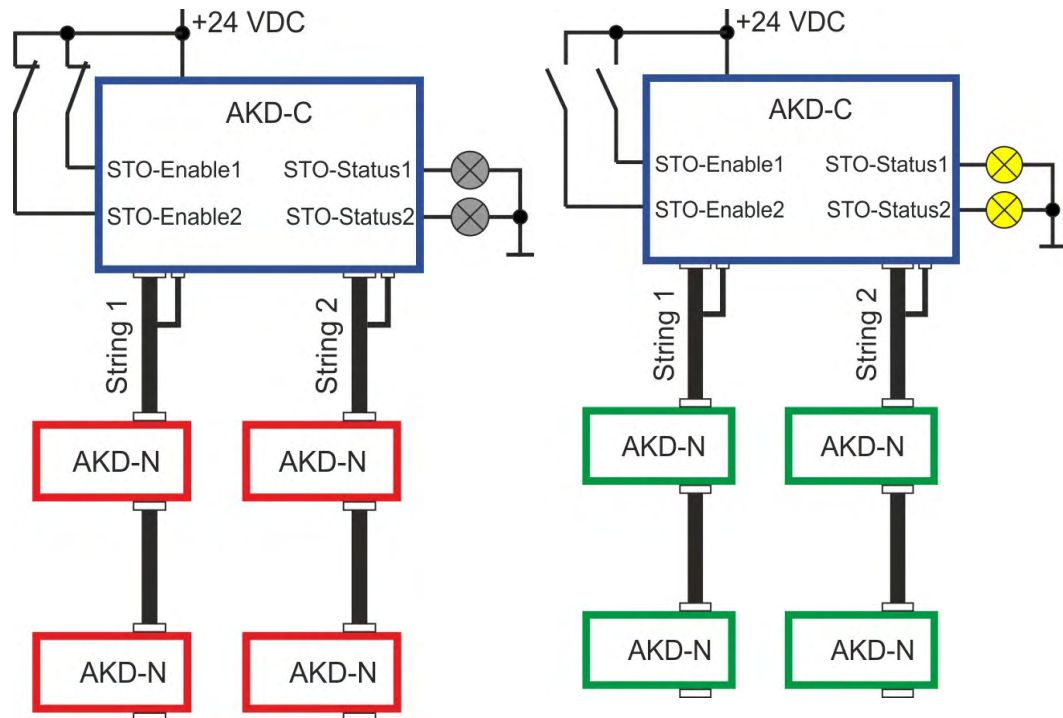

Torque for all drives released.

- unsafe status Strings 1&2
- STO-Enable1&2 +24 VDC
- STO-Status 1&2 „Low“

Torque for all drives safely locked.

- functional safe status for Strings 1&2
- STO-Enable 1&2 0 VDC
- STO-Status 1&2 „High“

Example: Global STO String 1

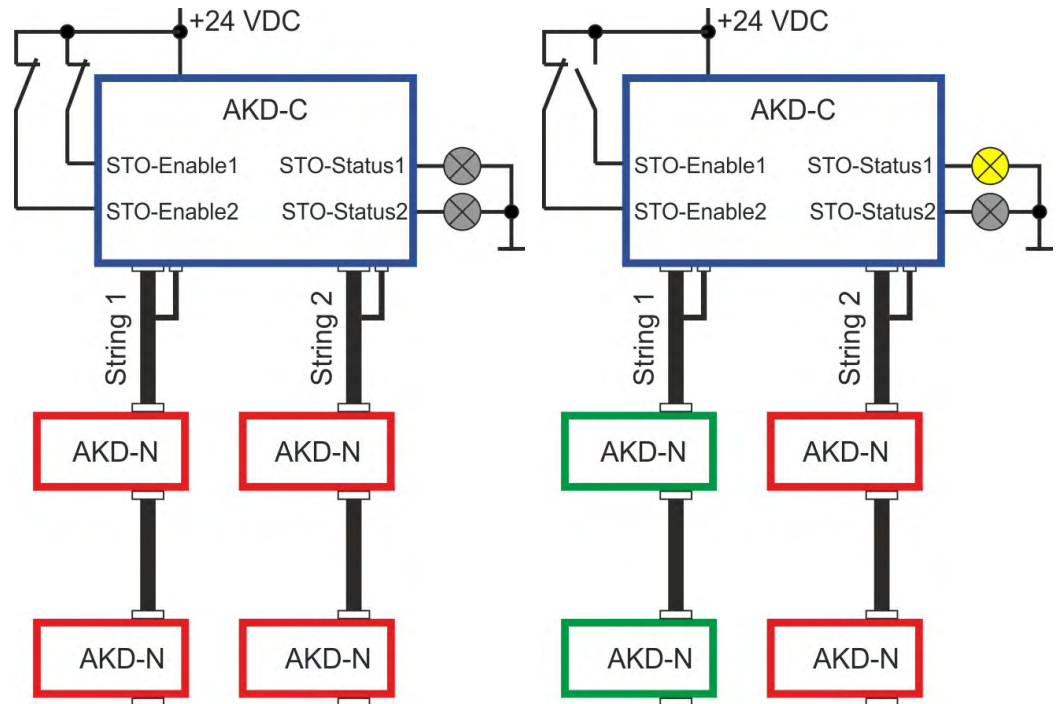

Torque for all drives released.

- unsafe status Strings 1&2
- STO-Enable1&2 +24 VDC
- STO-Status 1&2 „Low“

Torque for all String 1 drives is safely locked.

- functional safe status for String 1
- STO-Enable 1 >> 0 VDC
- STO-Status 1 >> „High“

Example: Global STO String 2

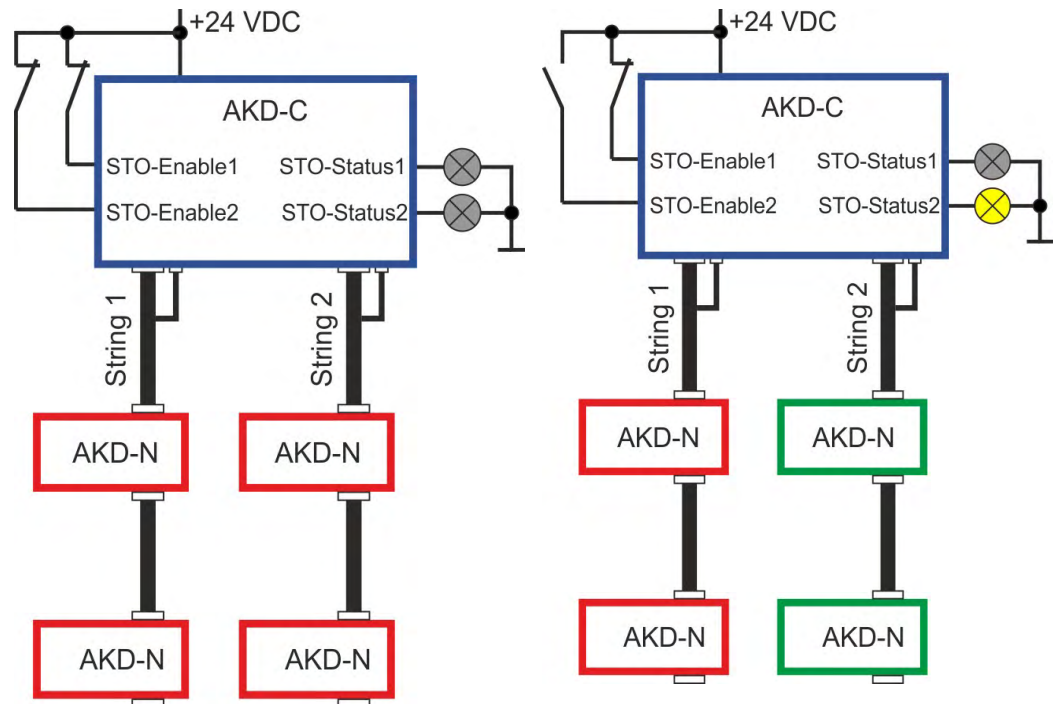

Torque for all drives released.

- unsafe status Strings 1&2
- STO-Enable1&2 +24 VDC
- STO-Status 1&2 „Low“

Torque for all String 2 drives is safely locked.

- functional safe status for String 2
- STO-Enable 2 >> 0 VDC
- STO-Status 2 >> „High“

5.3 Local STO

The AKD-N-DS and AKD-N-DT have a safe STO input (STO-Enable) with which the torque of the drive can be switched off safely. The input must be controlled through a safety relay or a safety controller.

In addition, a non-safe STATUS output (STO-STATUS) is available. The output can be evaluated in a PLC.

To slow down the drive to a standstill in a controlled manner, a 'controlled stop' (CSTOP) can be triggered through one of the three digital inputs available. The delay for the controlled stop is set via the parameter CS.DEC (see WorkBench online help). This non-safe input can be controlled both from a safety controller and from a PLC. There is no safety-related monitoring of the brake ramp.

Example: Local STO for one drive

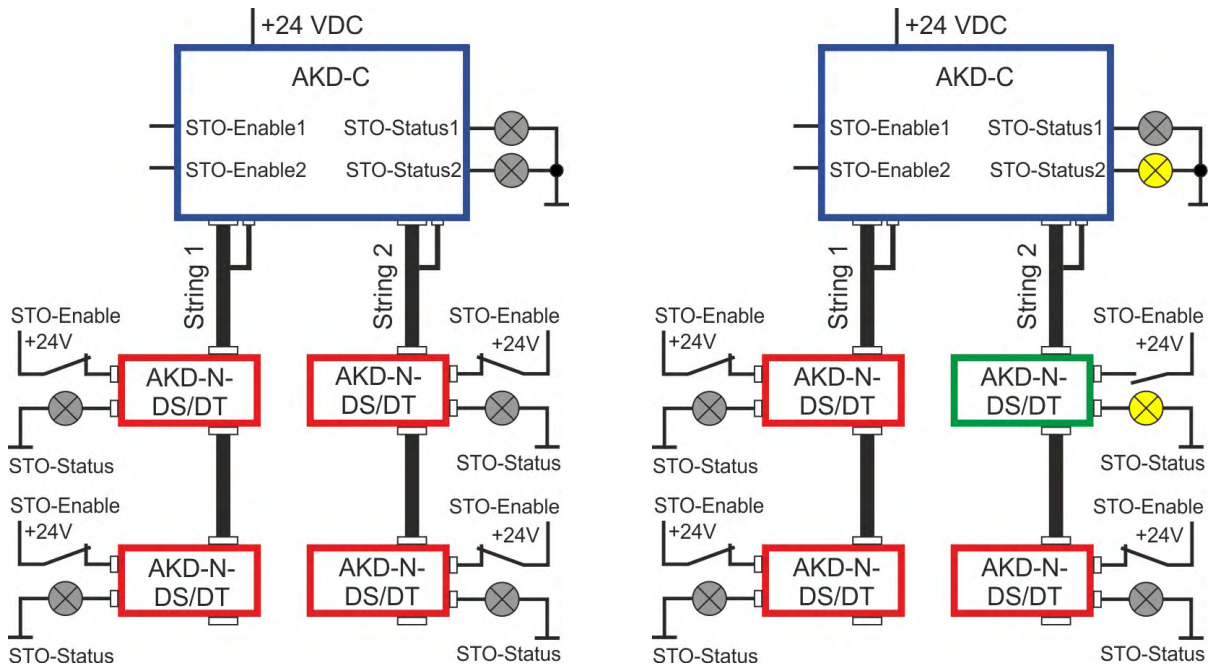

Torque for all drives released.

- AKD-C STO-Enable 1&2 >> irrelevant
- AKD-C STO-Status 1&2 >> „Low“
- all AKD-N STO-Enable >> +24 VDC
- all AKD-N STO-Status >> „Low“

Torque Drive 1 in String 2 safely locked.

- AKD-C STO-Enable 1&2 >> irrelevant
- AKD-C STO-Status 2 >> „High“
- String 2/AKD-N #1 STO-Enable >> 0 VDC
- String 2/AKD-N #1 STO-Status >> „High“

Example: Local STO for several drives

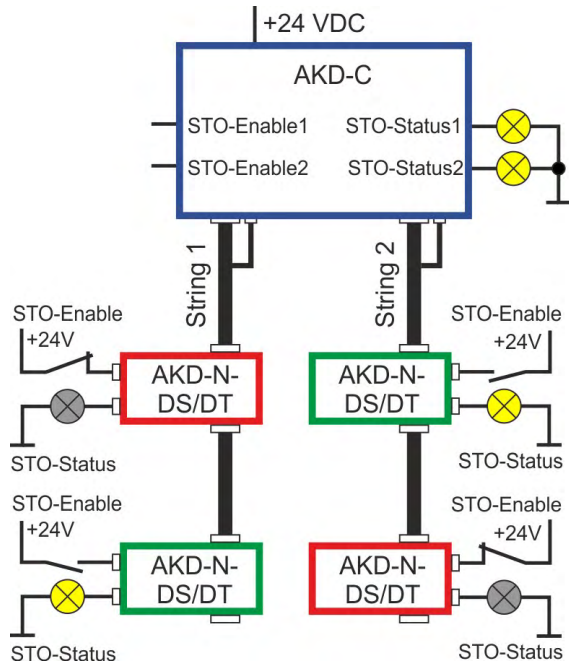

Torque Drive 2 in String 1 safely locked.
 Torque Drive 1 in String 2 safely locked..

- AKD-C STO-Enable 1&2 >> irrelevant
- AKD-C STO-Status 1&2 >> „High“
- String 2/AKD-N #1 STO-Enable >> 0 VDC
- String 1/AKD-N #2 STO-Enable >> 0 VDC
- String 2/AKD-N #1 STO-Status >> „High“
- String 1/AKD-N #2 STO-Status >> „High“

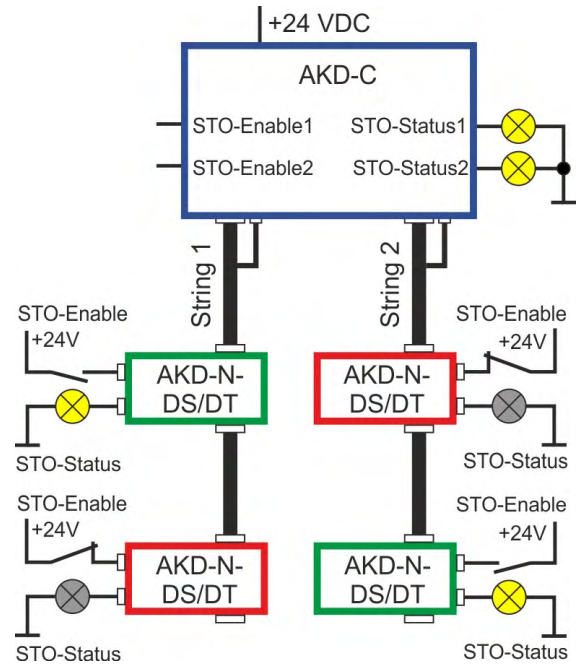

Torque Drive 1 in String 1 safely locked.
 Torque Drive 2 in String 2 safely locked.

- AKD-C STO-Enable 1&2 >> irrelevant
- AKD-C STO-Status 1&2 >> „High“
- String 1/AKD-N #1 STO-Enable >> 0 VDC
- String 2/AKD-N #2 STO-Enable >> 0 VDC
- String 1/AKD-N #1 STO-Status >> „High“
- String 2/AKD-N #2 STO-Status >> „High“

Example: Local STO with controlled stop (CSTOP)

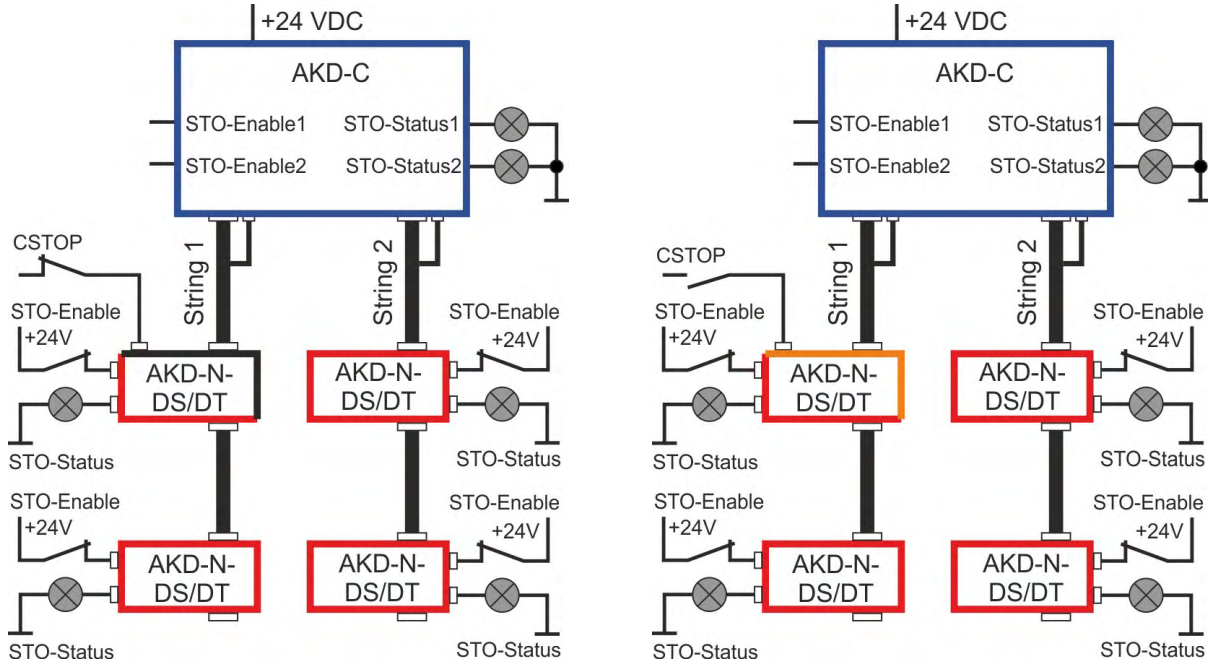

Torque for all drives released. Drive 1 in String 1 produces torque, CSTOP is not active.

- AKD-C STO-Enable 1&2 >> irrelevant
- AKD-C STO-Status 1&2 >> „Low“
- all AKD-N STO-Enable >> +24 VDC
- all AKD-N STO-Status >> „Low“
- String 1/AKD-N #1 CSTOP-Input >> +24 VDC

CSTOP for drive 1 in String 1 is activated, drive brakes, brake ramp is not supervised. Torque for all other drives is released.

- AKD-C STO-Enable 1&2 >> irrelevant
- AKD-C STO-Status 1&2 >> „Low“
- all AKD-N STO-Enable >> +24 VDC
- all AKD-N STO-Status >> „Low“
- String 1/AKD-N #1 CSTOP-Input >> 0 VDC

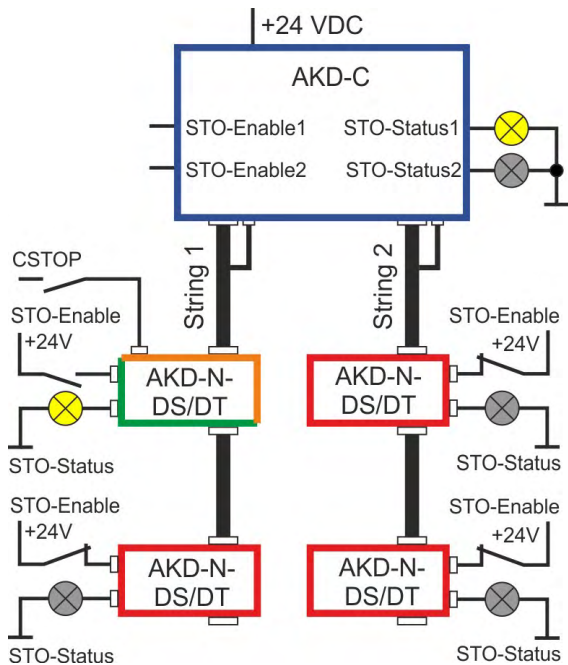

CSTOP for drive 1 in String 1 is activated, torque is safely locked. Torque for all other drives is released.

- AKD-C STO-Enable 1&2 >> irrelevant
- AKD-C STO-Status 1 >> „High“
- String 1/AKD-N #1 STO-Enable >> 0 VDC
- String 1/AKD-N #1 STO-Status >> „High“
- String 1/AKD-N #1 CSTOP-Input >> 0 VDC

5.4 Global / Local STO combination

To implement modular solutions and optional extensions, both STO versions can be combined with one another in a wide variety of ways.

AKD-N-DS and AKD-N-DT have a 'local STO' and can be switched torque-free individually. All other AKD-N devices can only be switched via the 'global STO' on the AKD-C.

Example: modular 3 + 2 + 1

Torque of the red drives is released, Torque of the green drives is safely locked.

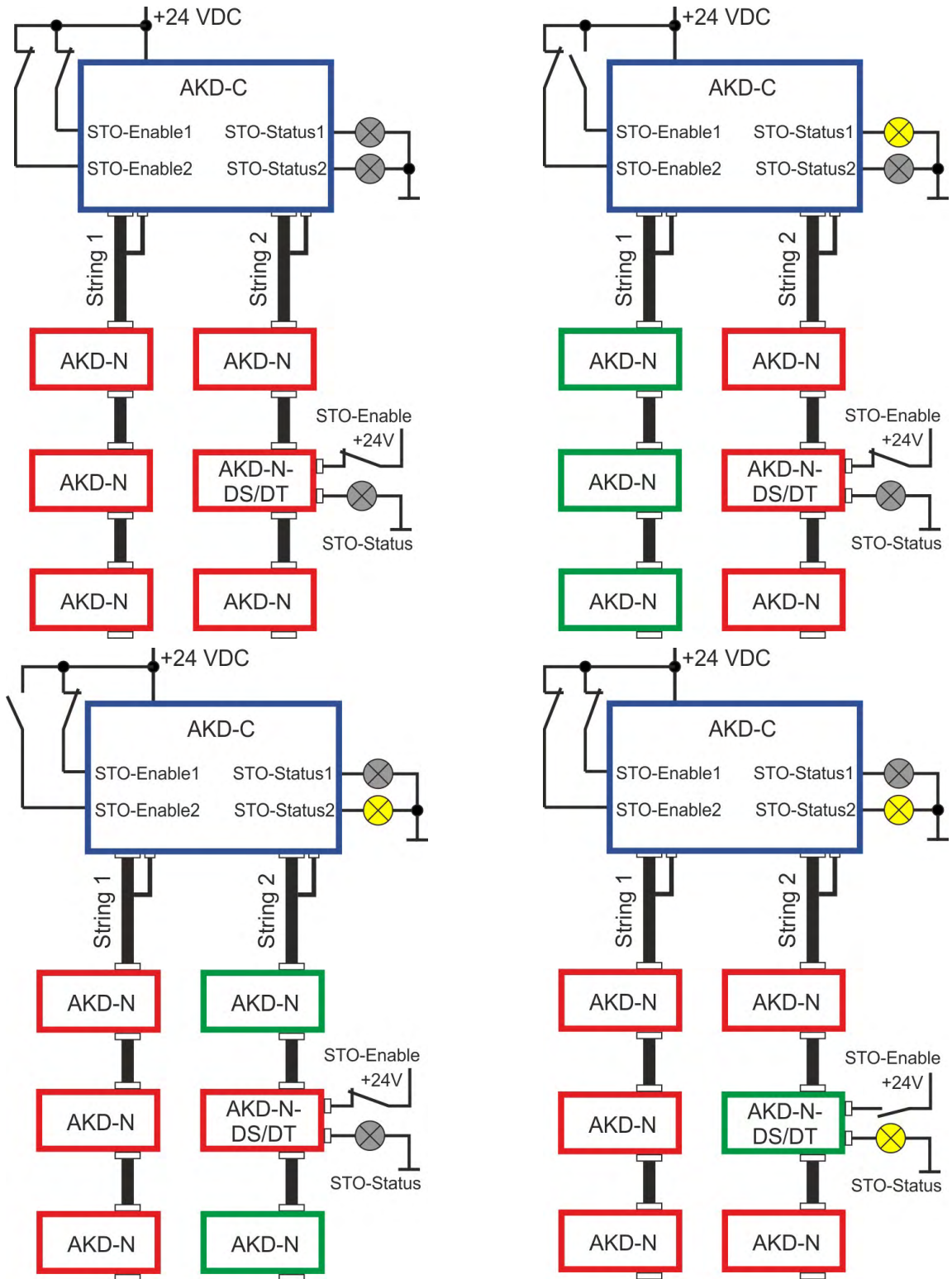

Example: modular 1 + 2 + 3

Torque of the red drives is released, Torque of the green drives is safely locked.

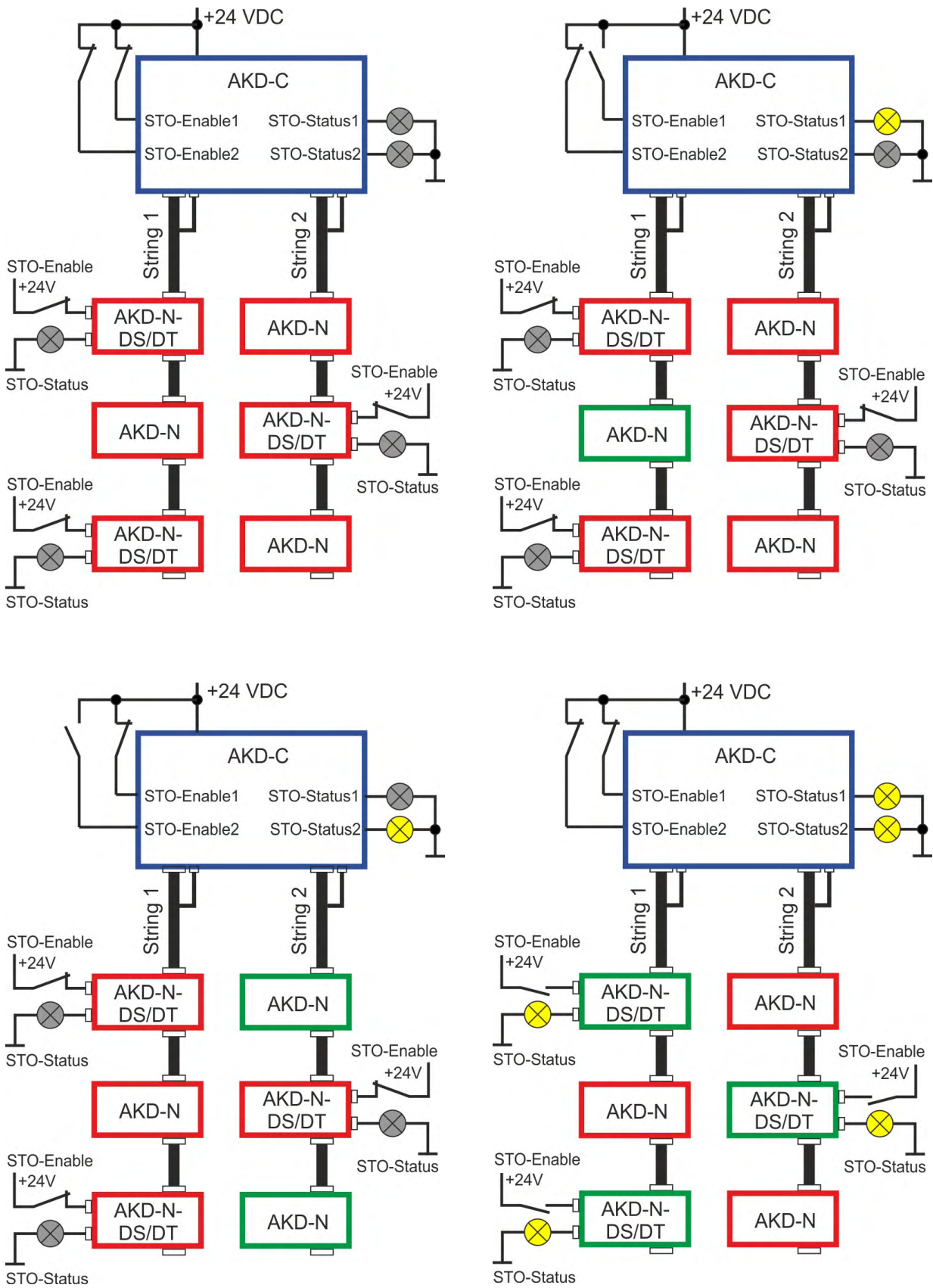

5.5 Calculation of Safety Levels for the STO function

5.5.1 Abbreviations

Abbreviation	
B _{10d}	Number of cycles until 10% of the components fail with caused danger
C	Duty cycles (per hour) of electro-mechanical devices
CCF	Common cause failure
DC	Fault diagnostic coverage
DC _{avg}	Fault diagnostic coverage (average)
HFT	Hardware fault tolerance
MTBF	Mean time in standard operation until fault occurs
MTTF	Mean time to failure
MTTF _d	Mean time to failure that cause danger
MTTR	Mean time to repair
PFH	Probability of failure per hour
PFHD	Probability of dangerous failure per hour
PL	Performance level
SBC	Safe Brake Control
SBT	Safe Brake Test
SDI	Safe Direction
SFF	Safe failure fraction
SIL	Safety integrity level
SILCL	Safety integrity claim limit
SLS	Safely Limited Speed
SOS	Safe Operating Stop
SRECS	Safety related electrical control system
SRP/CS	Safety related part of a control system
β	Susceptibility to common cause failure
SS1	Safe Stop 1
SS2	Safe Stop 2
SSR	Safe Speed Range
STO	Safe Torque Off
T ₁	Lifetime of proof test interval
T ₂	Diagnostic test intervall
T _M	Mission time
λ	Failure rate
λ_d	Failure rate with dangerous faults
λ_s	Failure rate with undangerous faults

5.5.2 General

With conventional servo amplifiers, the STO (Safe Torque Off) safety function is typically assigned uniquely to one individual device. This means the specified safety-related parameters are also assigned uniquely to one device.

With the decentralized drive system, at least two devices are assigned to one STO function, one AKD-C and at least one AKD-N. The safety-related parameters specified in the operating instructions therefore refer to the system; i.e. at least to two devices.

However, several AKD-Ns can be operated with one STO input; i.e. with one STO signal up to 8 AKD-Ns can be shut down (global STO). In this case, the PFH value cannot always be taken directly from the safety characteristics table given in the Installation Manual. Instead, you must investigate how many AKD-Ns are involved in one risk (e.g. restart) in order to then determine the entire PFH value.

5.5.3 AKD-C and AKD-N internal structure

The STO function can be considered a 'black box' by the user – understanding the signal path within the AKD-C, as well as the transmission to the first AKD-N and the distribution of the signal to all connected AKD-Ns is not required for determining the safety level.

The STO signal requires no additional cables between the devices. Instead, the signal is modulated onto an existing cable. The STO Signal on the AKD-C switches off the driver supply for all power semiconductors of the AKD-N devices, thus preventing the power output stages from supplying the motors with energy.

5.5.4 Safety-related features of the subsystem AKD-C and AKD-N

In principle, the "Safe Torque OFF" safety function in the decentralized AKD servo system is suitable for meeting the requirements of SIL 2 in accordance with EN 62061 and the PLd, cat. 3 in accordance with EN 13849-1. Characteristics:

STO	ISO 13849-1	IEC 62061	PFH [1/h]	SFF [%]	T _M [years]
global	PL d, CAT 3	SIL 2	2.9E-08	97.08	20

You cannot, however, assume that the required safety level SIL 2 or PLd will be achieved for the entire safety chain (sensors, logic, actuators) with the AKD subsystem. Instead, the resulting safety level must be calculated in each case. Due to the high degree of reliability of the decentralized AKD system (i.e. especially the very low PFH value), this typically does not represent a problem. By way of assistance, we shall explain the procedure using an example (→ p. 42).

5.5.5 Essential safety considerations in accordance with EN 61800-5-2

The STO function as laid out in EN 61800-5-2 is a safety function which prevents an unexpected start-up by interrupting the supply of power to the motor.

- This safety function equates to an uncontrolled shutdown in accordance with IEC 60204-1, stop category 0 (→ p. 43).
- With vertical axes or large dimensions, additional measures may be necessary (e.g. mechanical brake) to prevent dangers.
- There is no monitoring of the standstill position.
- The STO circuit does not provide adequate protection against electric shock; i.e. additional measures for galvanic isolation could be necessary.

5.5.5.1 Risk analysis in accordance with ISO 12100:2010

The standard ISO 12100:2010 provides essential information concerning the procedure for risk assessment and risk minimization; in particular, the '3-stage method' should be considered:

1. Inherently safe design.
2. Technical protective measures.
3. Information on residual risk.

The standard ISO 13849 describes the procedure for determining the required performance level 'PLr'. First the possible extent of injury is determined; then the length of time the person is exposed to the present risk is estimated; finally the risk is distinguished based on the possible fault prevention. The estimation of the required safety level should be represented in the graph displayed below.

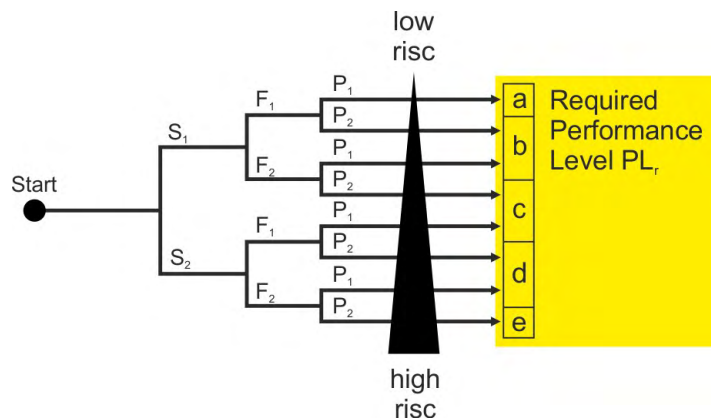

S = Seriousness of the injury

S₁ = Minor injury (usually reversible)

S₂ = Serious injury, including death (usually irreversible)

F = Frequency and/or duration of risk exposure

F₁ = Seldom to often and/or brief duration

F₂ = Frequent to continuous and/or long duration

P = Possibilities for hazard prevention

P₁ = Possible under certain conditions

P₂ = Barely possible

For most applications the required performance level is PL_d or lower. In rare cases, the performance level PL_e may be required. In this case, Kollmorgen offers support for individual, additional measures.

The safety of machinery and machine control systems can be evaluated as part of EN 13849-1 using the software assistant SISTEMA of the IFA ((Institute for Occupational Safety and Health of the German Social Accident Insurance www.dguv.de/ifa). You can find a Sistema library with Kollmorgen products at the Kollmorgen web site.

5.5.6 Safety-related assessment of the system according to ISO 13849-1

Example application: Simple handling system with a horizontal axle (X), a vertical axle (Y), and a conveyor belt drive (F).

Firstly, all subsystems of the safety chain 'STO' must be displayed with their safety-related parameters in a block diagram. In this process, the number of connected AKD-Ns on the AKD-C is insignificant. Instead, only the AKD-N simultaneously involved in the 'restart' risk must be considered.

In our example, a start-up of the X-axis and a start-up of the Y-axis could pose a risk for users. Therefore, both AKD-Ns must be considered subsystems of the safety chain. On the other hand, a third AKD-N on the AKD-C, which serves as a drive for the conveyor belt, can remain unconsidered, since no danger is posed from the movement of the conveyor belt in the example. The figure below thus presents all subsystems of the STO safety function. The user must ensure that all subsystems correspond to at least category 3 and the performance level PLd.

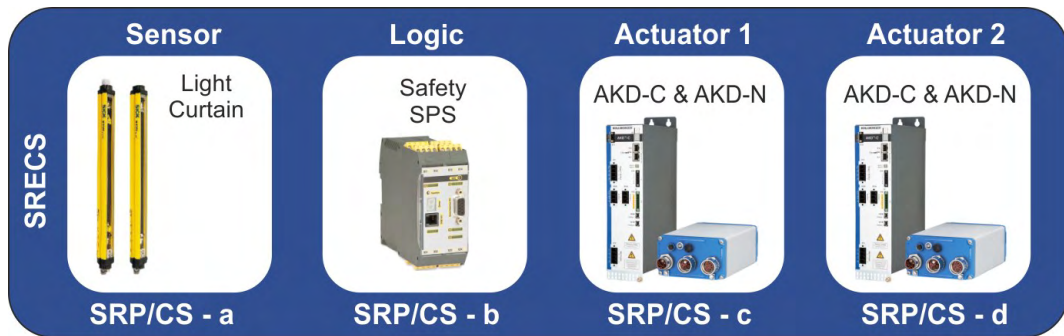

If additional drives were to be involved in the 'restart' risk, their STO parameters would also have to be adopted in the safety chain.

Determining the resulting performance level for the STO safety function.

The PFH value of the overall system (i.e. the entire STO safety chain) must be in the permitted range for PLd. The PFH overall value is deduced from the sum of the PFH values of the subsystems.

To achieve the PLd, the PFH value must be lower than $< 10^{-6}$; in other words, an overall PFH value of at least 9.47×10^{-7} is required !

The parameters are presented in the figure below for clarity:

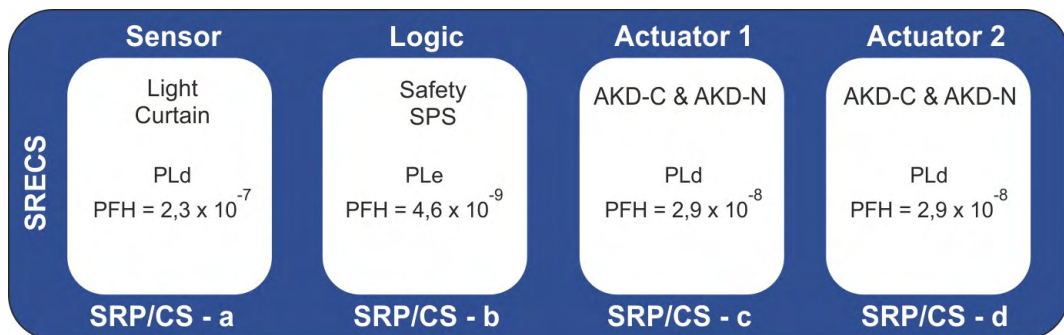

Now the PFH values must be summarized:

$$PFH_{total} = PFH_{Sensor} + PFH_{Logic} + PFH_{Actuator1} + PFH_{Actuator2}$$

$$PFH_{total} = 2.3 \times 10^{-7} + 4.6 \times 10^{-9} + 2.9 \times 10^{-8} + 2.9 \times 10^{-8}$$

$$PFH_{total} = 2.9 \times 10^{-7} \Rightarrow \text{PLd for the overall system is achieved!}$$

Upon closer consideration, it becomes clear that typically the sensor has the greatest influence on the PFH overall value, since the PFH values for AKD are of a very high quality.

5.6 Stop / Emergency Stop / Emergency Off

The control functions Stop, Emergency Stop and Emergency Off are defined by IEC 60204. Notes for safety aspects of these functions can be found in ISO 13849 and IEC 62061.

NOTICE

The parameter DRV.DISMODE must be set to 2 for every connected AKD-N to implement the different stop categories. Consult the *AKD-N User Guide* for configuring the parameter.

5.6.1 Stop

The stop function shuts down the machine in normal operation. The stop function is defined by IEC 60204.

NOTICE

The Stop Category must be determined by a risk evaluation of the machine.

Stop function must have priority over assigned start functions. The following stop categories are defined:

Stop Category 0

Shut-down by immediate switching-off the energy supply to the drive machinery (this is an uncontrolled shut-down). With the approved safety function STO the drive can be stopped using its internal electronics (IEC 61508 SIL2).

Stop Category 1

A controlled shut-down, whereby the energy supply to the drive machinery is maintained to perform the shut-down, and the energy supply is only interrupted when the shut-down has been completed.

Stop Category 2

A controlled shut-down, whereby the energy supply to the drive machinery is maintained.

Stop Category 0 and Stop Category 1 stops must be operable independently of the operating mode, whereby a Category 0 stop must have priority.

If necessary, provision must be made for the connection of protective devices and lock-outs. If applicable, the stop function must signal its status to the control logic. A reset of the stop function must not create a hazardous situation.

5.6.2 Emergency Stop

The Emergency Stop function is used for the fastest possible shutdown of the machine in a dangerous situation. The Emergency Stop function is defined by IEC 60204. Principles of emergency stop devices and functional aspects are defined in ISO 13850.

The Emergency Stop function will be triggered by the manual actions of a single person. It must be fully functional and available at all times. The user must understand instantly how to operate this mechanism (without consulting references or instructions).

NOTICE

The Stop Category for the Emergency Stop must be determined by a risk evaluation of the machine.

In addition to the requirements for stop, the Emergency Stop must fulfil the following requirements:

- Emergency Stop must have priority over all other functions and controls in all operating modes.
- The energy supply to any drive machinery that could cause dangerous situations must be switched off as fast as possible, without causing any further hazards (Stop Category 0) or must be controlled in such a way, that any movement that causes danger, is stopped as fast as possible (Stop Category 1).
- The reset must not initiate a restart.

5.6.3 Emergency Off

The Emergency Off function is used to switch-off the electrical power supply of the machine. This is done to prevent users from any risk from electrical energy (for example electrical impact). Functional aspects for Emergency Off are defined in IEC 60364-5-53.

The Emergency Off function will be triggered by the manual actions of a single person.

NOTICE

The result of a risk evaluation of the machine determines the necessity for an Emergency Off function.

Emergency Off is done by switching off the supply energy by electro-mechanical switching devices. This results in a category 0 stop. If this stop category is not possible in the application, then the Emergency Off function must be replaced by other measures (for example by protection against direct touching).

This page intentionally left blank.

About KOLLMORGEN

Kollmorgen is a leading provider of motion systems and components for machine builders. Through world-class knowledge in motion, industry-leading quality and deep expertise in linking and integrating standard and custom products, Kollmorgen delivers breakthrough solutions that are unmatched in performance, reliability and ease-of-use, giving machine builders an irrefutable marketplace advantage.



Join the [Kollmorgen Developer Network](#) for product support. Ask the community questions, search the knowledge base for answers, get downloads, and suggest improvements.

North America

KOLLMORGEN

201 West Rock Road
Radford, VA 24141, USA

Web: www.kollmorgen.com

Mail: support@kollmorgen.com

Tel.: +1 - 540 - 633 - 3545

Fax: +1 - 540 - 639 - 4162

Europa

KOLLMORGEN Europe GmbH

Pempelfurtstr. 1
40880 Ratingen, Germany

Web: www.kollmorgen.com

Mail: technik@kollmorgen.com

Tel.: +49 - 2102 - 9394 - 0

Fax: +49 - 2102 - 9394 - 3155

South America

KOLLMORGEN

Avenida João Paulo Ablas, 2970
Jardim da Glória, Cotia – SP
CEP 06711-250, Brazil

Web: www.kollmorgen.com

Mail: contato@kollmorgen.com

Tel.: +55 11 4615-6300

China and SEA

KOLLMORGEN

Floor 4, Building 9, No. 518,
North Fuquan Road, Changning District,
Shanghai 200335, China

Web: www.kollmorgen.cn

Mail: sales.china@kollmorgen.com

Tel.: +86 - 400 661 2802

KOLLMORGEN®

Because Motion Matters™