

# Seco

## AC/DC Drives

# BVFD163 & BVFD163WD QUICK START GUIDE

Variable-frequency drives for 3-phase and single-phase AC motors

BVFD163 & BVFD163WD DIMENSIONS

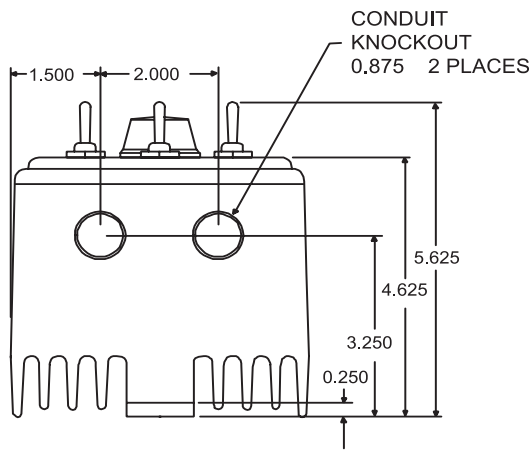
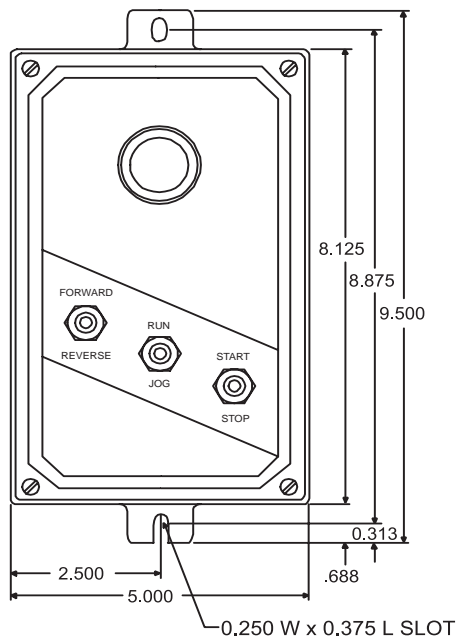

BVFD163 & BVFD163WD CIRCUIT BOARD LAYOUT

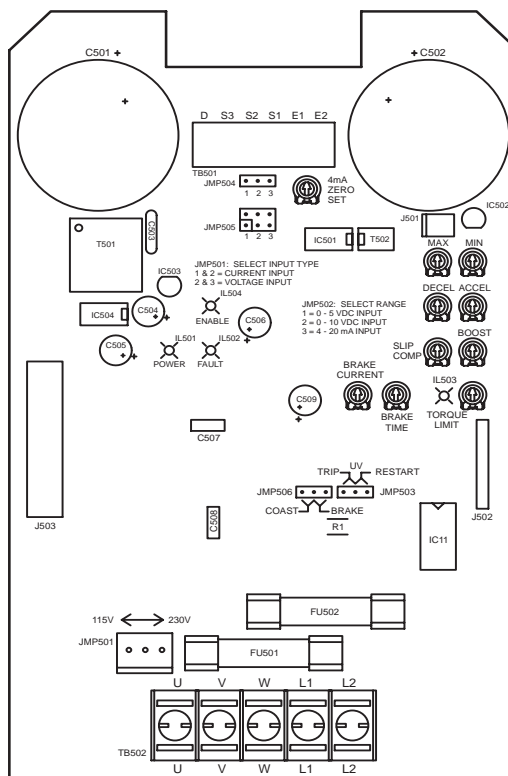

AC LINE CONNECTIONS

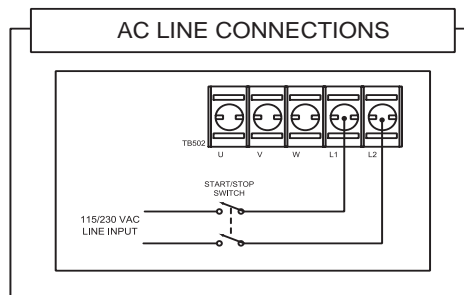

MOTOR CONNECTIONS

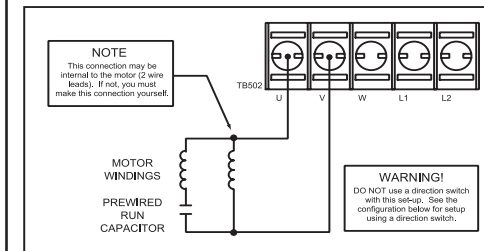

SINGLE-PHASE OPERATION  
(Motor with pre-wired capacitor)

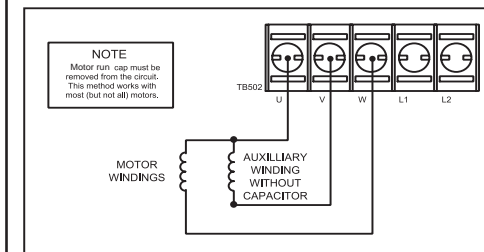

SINGLE-PHASE OPERATION  
(Configured for use with DIRECTION switch)

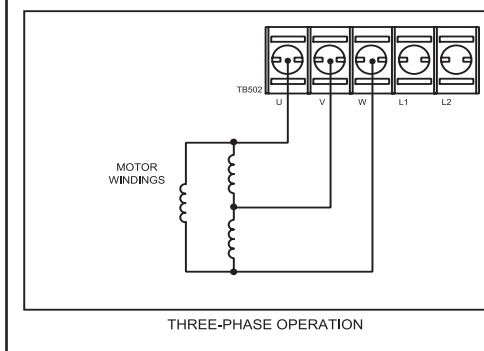

THREE-PHASE OPERATION

Copyright © 2004 by  
Danaher Motion

All rights reserved. No part of this manual may be reproduced or transmitted in any form without written permission from Danaher Motion. The information and technical data in this manual are subject to change without notice. Danaher Motion and its Divisions make no warranty of any kind with respect to this material, including, but not limited to, the implied warranties of its merchantability and fitness for a given purpose. Danaher Motion and its Divisions assume no responsibility for any errors that may appear in this manual and make no commitment to update or to keep current the information in this manual. KC0304

Printed in the United States of America.

Danaher Motion  
www.danahermotion.com  
13500-J South Point Blvd, Charlotte, NC 28273 USA  
Phone: (540) 633-3400; Fax: (540) 639-4165

Document Number: 250-0385, Revision 0; Printed in the U.S.A. - December 2004

## CALIBRATION SETTINGS

### 4mA ZERO SET

The 4mA ZERO SET trimpot sets zero speed when a 4-20mA input signal is used.

### Maximum Speed (MAX)

The MAX setting determines the motor speed when the speed adjust potentiometer is turned full CW.

Rotate the speed adjust potentiometer full CW. Using a hand-held tachometer or analog frequency meter as a reference, adjust the MAX trimpot until the desired speed or frequency is reached.

### Minimum Speed (MIN)

The MIN setting determines the motor speed when the speed adjust potentiometer is turned full CCW. It is factory set to zero speed. The MIN setting range is 0 to 30% MAX setting.

To calibrate MIN, turn the speed adjust potentiometer CCW. Adjust the MIN trimpot until the motor has stopped (for zero speed setting), or is running at the desired minimum speed.

### Deceleration Time (DECEL)

The DECEL setting determines the time the motor takes to ramp to a lower speed. Decel is factory set for the fastest deceleration time (full CCW).

To set the deceleration time:

1. Set the speed adjust potentiometer to maximum (full CW) and wait for the motor to come to maximum speed.
2. Set the speed adjust potentiometer to minimum speed (full CCW) and note the time the motor takes to decelerate to minimum speed.
3. If the deceleration time differs from the desired time, adjust the DECEL trimpot until the desired time is reached. Rotating the DECEL pot CW increases the deceleration time.

### Acceleration Time (ACCEL)

The ACCEL setting determines the time the motor takes to ramp to a higher speed. ACCEL is factory set for the fastest acceleration time (full CCW).

To set acceleration time:

1. Set the speed adjust potentiometer to zero (full CCW) and wait for the motor to come to a stop (or minimum speed).
2. Set the speed adjust potentiometer to maximum speed (full CW) and note the time the motor takes to accelerate to maximum speed.
3. If the acceleration time differs from the desired time, adjust the ACCEL trimpot until the desired time is reached. Rotating the ACCEL trimpot CW increases the acceleration time.

### Slip Compensation (SLIP COMP)

The SLIP COMP setting controls speed regulation during load changes. The SLIP COMP range is 0 - 5 Hz at base speed and load.

Increase the motor speed to maximum. Slowly load the motor until the AC phase current is at its maximum (100%). If the motor shows any signs of slowing, rotate the SLIP COMP trimpot CW until the motor shaft rotates at the original set speed.

### BOOST

The BOOST setting is used to increase motor torque at low speeds. The minimum setting is sufficient for most applications and does not need to be adjusted. If the motor stalls or runs too slowly due to excessive slip at very low speeds (below 10 Hz), the boost trimpot may need adjustment.

To adjust the BOOST setting:

1. Run the motor at the lowest continuous frequency/speed required.
2. Monitor the motor phase current (with a true RMS meter) while very slowly turning the BOOST trimpot CW until the motor operates properly, or 100% of the motor nameplate current is reached.

Note: Use the absolute minimum amount of BOOST necessary to achieve proper motor operation. Improper use of the BOOST feature may cause motor and/or drive overheating and failure. If proper motion operation cannot be achieved with the above procedure, please contact your Danaher Motion representative for assistance.

### TORQUE LIMIT

The TORQUE LIMIT setting determines the maximum torque for accelerating and driving the motor. TORQUE LIMIT is factory set at 100% of rated motor current. Although the TORQUE LIMIT trimpot can be set up to 100% of the drive nameplate rating, continuous operation beyond the drive nameplate rating may cause damage to the motor and/or drive.

To set the torque limit:

1. With no power applied to the drive, connect a (true RMS) ammeter in series with one of the motor leads.
2. Set the TORQUE LIMIT trimpot to full CCW.
3. Carefully lock the motor shaft. Ensure that the motor is firmly mounted.
4. Apply line power. The motor should be stopped.
5. Set the speed adjust potentiometer to maximum speed. The motor should remain stopped.
6. Slowly rotate the TORQUE LIMIT trimpot clockwise (CW) until the ammeter reads 100% of maximum motor current.
7. Set the speed adjust potentiometer to zero speed.
8. Remove power from the drive.
9. Remove the lock from the motor shaft.
10. Remove the ammeter in series with the motor lead.

### BRAKE CURRENT

The BRAKE CURRENT setting controls the amount of braking current applied, ranging from 0 - 100% of drive rating.

To set brake current:

Rotate the BRAKE CURRENT trimpot CW to increase the amount of current applied. Rotate the BRAKE CURRENT trimpot CCW to decrease the amount of current applied.

### BRAKE TIME

The BRAKE TIME setting controls the amount of time brake current is applied to the drive. The BRAKE TIME range is 1 to 10 seconds.

To set the brake time:

Rotate the BRAKE TIME trimpot CW to increase the amount of time the drive takes to brake. Rotate the BRAKE TIME trimpot CCW to decrease the amount of time the drive takes to brake.

## SPECIFICATIONS

1-Phase Input	.....*	115/230 VAC
1 or 3 -Phase Output	.....	.230 VAC
Maximum Horsepower	.....	.1 HP
Maximum Continuous Output Current	.....	† 4.0 AC
AC Amps In	.....	.15 / 10 amps
AC Voltage Input Range	.....	.115/230 VAC ± 10%
		50/60 Hz single phase
Standard Carrier Frequency	.....	.16 KHz
Output Frequency Range	.....	.0 - 120 Hz
Adjustable Maximum Output Frequency Range	.....	.30 - 120 Hz
Acceleration Time Range	.....	.1 - 12 secs
Deceleration Time Range	.....	.1 - 12 secs
Analog Input Voltage Range		
(S1 [-] to S2 [+])	.....	0 - 5 VDC, 0 - 10 VDC, 4 - 20 mA
Input Impedance, S1 to S2	.....	~ 100K ohms
Vibration	.....	.0.5G max (20 - 50 Hz)
		0.1G max (> 50 Hz)
Weight	.....	.1.2 lbs
Ambient Operating Temperature Range	.....	.10° - 40° C

\* Connect only 115 VAC line input to the 115 VAC terminals. Application of 230 VAC line input when set for 115 VAC will result in severe damage to the motor and drive.

† Derate current by 2% per degree if the operating temperature is above 40°C. Under no circumstances may the ambient temperature exceed 55°C.

## JUMPER SETTINGS

### JMP504

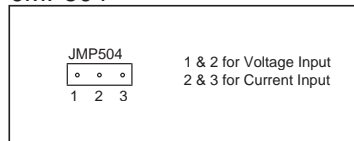

### JMP505

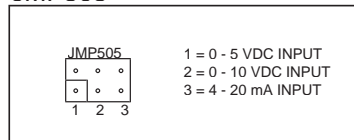

### JMP506

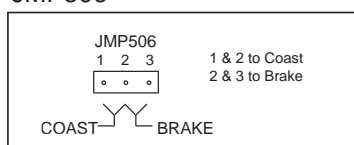

### JMP503

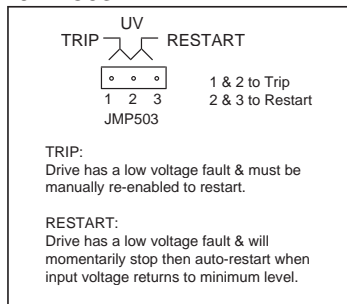

### JMP501

