

This is a Discontinued Product

Contact Kollmorgen Customer Support at
1-540-633-3545 or email us at support.kollmorgen.com
if assistance is required.

D2500

Analog Position Control

Operator's Manual

P/N PCW—4198 Rev 1.1 6/99

This manual covers the following IDC Products;

D2500 Analog Position Control
Circuit Boards Only

D2501 Analog Position Control with
Circuit Boards, Power Supply
and Chassis

D2502 Analog Position Control with
Circuit Boards, Power Supply,
Chassis and Cover

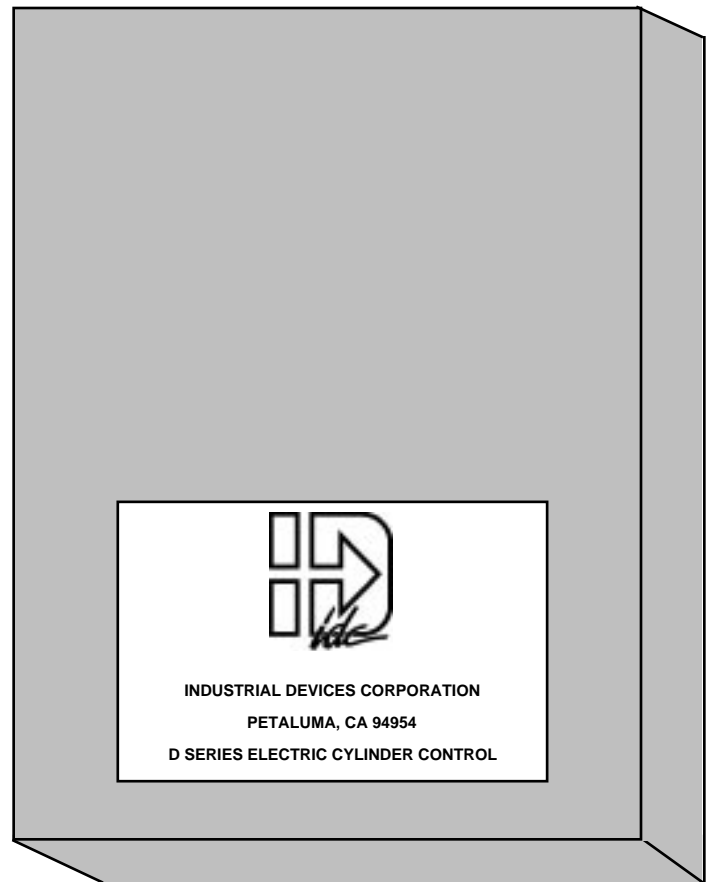

**INDUSTRIAL
DEVICES
CORPORATION**



Overview and Table of Contents

Overview

D2500 Series Controls are analog position controls which accept an analog voltage or current command input and translates the signal into a proportional linear displacement. The controls are used with ND and RD Series Electric Cylinders containing a linear potentiometer option and a user supplied command input of 0 - 5vdc, 0 - 10 vdc, or 4 - 20ma. Feedback from the linear potentiometer, proportional to distance, is sent back to the control which compares it to the scaled command input, providing a closed loop linear positioning system.

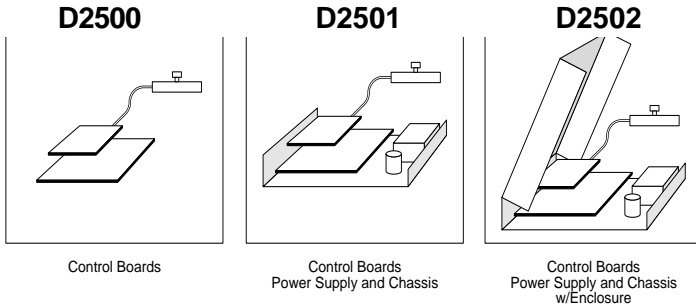

Compatible IDC Cylinders

ND Series Cylinders; of Standard Length (2, 4, 6, 8, 12, 18 and 24 inches) containing a -L- Linear Potentiometer Option

RD Series Cylinders; of Standard Length (12, 18 and 24 inches) containing a -L- Linear Potentiometer Option

Table of Contents

1. Control Hardware

A. Hardware Locations	3
B. Hardware Descriptions	
1. Potentiometers	3
2. LED Indicators	5
3. Dipswitches	6
4. Run/Jog Jumper, Fuse, & Joystick Slide Pot	6

2. Wiring Diagrams & I/O Descriptions

A. Terminal Listings	7
System Block Diagram	7
B. Power Supply Wiring	7
C. Motor Wiring	8
D. Linear Potentiometer Feedback & External Command Signal	8
E. STOP & DISABLE Inputs	9
F. STALL & IN POSITION Outputs	9

3. Setup & Operation

A. Operating Principles	10
B. System Setup	10
1. Joystick Control	11
2. 0-5 VDC analog input	11
3. 0-10 VDC analog input	12
4. 4-20 ma current input	12

4. Appendices

Appendix A: Linear Potentiometer Option	13
Appendix B: D Series Motors (Standard and Inline)	13
Appendix C: ND & RD Series Cylinders	13
Appendix D: Troubleshooting	14
Warranty & Service Policy	15

Specifications

Electrical:

Power Requirements:

*D2500	+20 - 30 VDC; 10 amps maximum
*D2501, D2502	105 - 125 VAC; 50/60 Hz @ 2 amps max.
(Jumper Selectable)	208 - 245 VAC; 50/60 Hz @ 1 amp max.

Motor Output:

*0-28vdc, @ 5 amps max (control clamps current to 5amp limit)

Inputs:

*Stop Sinking Input (1K Pullup to 12 VDC)

High Level (Off) 10.5 - 12.25 VDC (open circuit high)

Low Level (Activated) 0 - .8 VDC (sinking to ground) @ 12ma max

*Disable

Optically-Isolated, Sinking or Sourcing Input 10 - 30 VDC at 20ma max

*External Reference

0 - 5VDC, 0 - 10VDC, or 4 - 20ma

Outputs:

*Stall,IN POS Open Collector Sinking Output; 1K pull up to 12VDC

High Level (OFF) 10.5 - 12 VDC (open circuit high)

Low Level (ON) 0 - .5 VDC capable of sinking 100ma to ground

Operational:

*Variable Speed Reduction	15:1
*Nominal Motor Chopping Frequency	2000Hz

Environmental:

*Operating Temperature	32 to 122F (0 to 50C)
*Storage Temperature	-40 to 185F (-40 to 85C)

Mounting Dimensions:

Model	Length (in.)	Width (in.)	Depth (in.)
*D2500 (Boards)	5.5	5.0	1.2
*D2501, D2502	10.0	6.2	2.9

*Allow 2.25 inches clearance beyond the chassis length to replace fuse on the D2501 & D2502.
*For Chassis Diagram on right, the parenthesis indicate millimeters(mm).

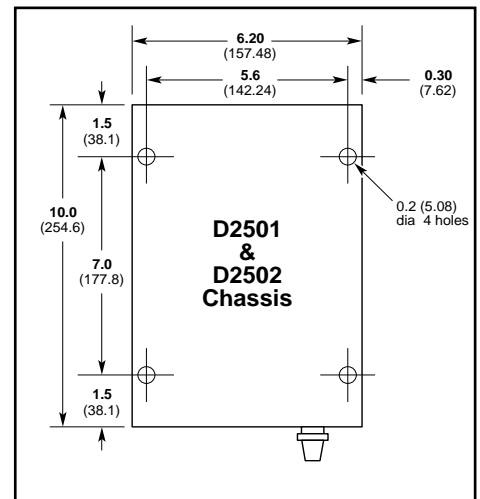

Chapter 1 Control Hardware

A. Hardware Locations

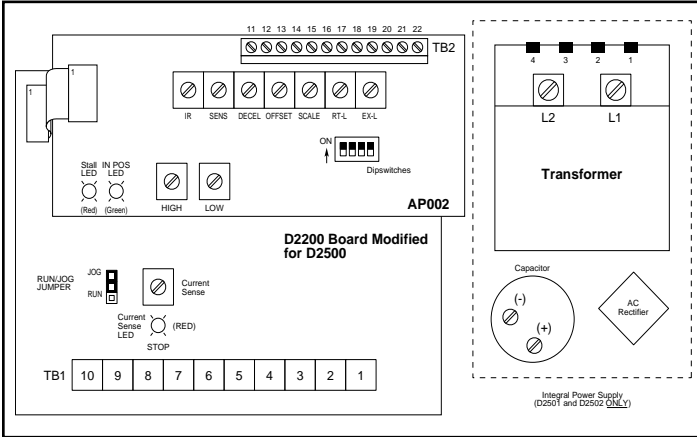

B. Hardware Descriptions

Functional Hardware

10	Potentiometers	1	RUN/JOG Jumper
3	LED Indicators	1	Joystick Slide Pot (External to Control)
4	Dipswitches	1	Fuse (D2501 & D2502 ONLY)

Electrical Interface Connectors

TB1 (10 Pin Terminal Connector)

Terminal #	Label
1	GND
2	+24V
3	M-
4	M+
5	COM
6	—
7	—
8	Stop
9	—
10	—

TB2 (12 Pin Terminal Connector)

Terminal #	Label
11	+5V
12	LPO Input
13	GND
14	GND
15	+5V
16	REF Input
17	Joystick Input
18	GND
19	Stall Output
20	IN POS Output
21	Disable +
22	Disable-

1. Potentiometers

Ten potentiometers are available to tune and adjust the control to optimize system response & performance.

CW : Clockwise Rotation
CCW : Counter Clockwise Rotation

- Current Sense**
- High** (Maximum Move Speed)
- Low** (Low Speed Gain)
- IR** (IR Compensation)
- Sens** (Sensitivity Gain)
- Decel** (Deceleration)
- EX-L** (Extend End of Travel Limit)
- RT-L** (Retract End of Travel Limit)
- Scale** (Reference Input Scale Factor)
- Offset** (4-20ma Zero Offset Voltage)

a. Current Sense

Single turn potentiometer which sets the sensing threshold for current going to the motor. This setting will determine the cylinders thrust potential and the current threshold which designates a stall condition.

(Full CCW = 0% (0 amps), 1/2 turn CW = 50% (5 amps), Full CW = 100% (clamped to 5 amps))

Rotation CW Increases Current Sense
CCW Decreases Current Sense

Note 1: If the current threshold is exceeded, the control will enter a stall condition where power is shut off to the motor, the Stall LED will come ON, and the Stall Output will activate(sink to ground).

Note 2: The D2500 control clamps motor current to 5 amps max, any current sense setting greater than half a turn (50% or 5 amps), disables the current sensing feature. Earlier versions of the control (AP002 Rev A, or AP002 Rev B without MOD 502) allow the current sense pot to set a threshold of upto 10 amps (Full CW).

It is recommended that users with earlier control versions set the current sense potentiometer to 50% or less to protect against excessive current draw created from any physical binding in the load or the leadscrew or from the high average current linked to high duty cycle applications.

Setting too LOW: Excessive Stalling
Setting too HIGH: Stall Detection Feature Disabled

Stall

Condition: Occurs when motor current exceeds the current sensing threshold set by the current sense potentiometer. This condition can be caused by the following;

A: Current Surges

- Trying to accelerate or decelerate the motor too fast.
- Trying to move a load faster than the motor is capable
- Rapid or frequent changes in direction causing a regen condition where power is fed back into the amplifier
- Cylinder or load is physically jammed.

B: High Running Current due to a heavy load, a rapid traverse, or a high duty cycle.

C: Current Sense Potentiometer setting too low.

Stall Results

- Current Shut OFF to motor
- Stall LED turns ON
- Stall output activated

To Clear the stall condition, execute one of the following;

- Reverse Polarity of the Reference Signal (change motor direction)
- Cycle the input power
- Momentarily activate the STOP input (20ms)
- Momentarily activate the Disable input (20ms)



Chapter 1 Control Hardware

b. HIGH: (Maximum Move Speed) Single turn potentiometer which sets the main move speed of the cylinder. The setting is a percentage of the Available Linear Speed of a given cylinder. (Full CCW = 0% speed, Full CW = 100% speed)

Rotation CW Increases Move Speed
CCW Decreases Move Speed

Note 1: Available Linear Move Speeds are dependent upon the Model Number of the Cylinder being used. Reference Appendix C for a complete listing of ND and RD Series Cylinders and their available linear speeds.

Setting too LOW: Low Speed Instability
Setting too HIGH: Cylinder Overshooting Position

c. LOW: (Low Speed Gain) Single turn potentiometer which sets the low speed gain of the motor when the cylinder decels into its final creep speed prior to stopping.

Rotation CW Increases Low Speed Gain
CCW Decreases Low Speed Gain

Setting too LOW Cylinder does not achieve final position (IN POSITION) or takes an excessive time to reach final position.

Setting too HIGH: Cylinder oscillates (hunts) about the final position. (IN POS LED flickers)

d. IR: (IR Compensation) Single turn potentiometer which sets the current regulation of the motor on the cylinder when it is operating at low speeds.

Rotation CW Increases low speed current regulation
CCW Decreases low speed current regulation

Note 1: The majority of applications will NOT require adjustment of the "IR" factory setting (full CCW). It should be adjusted ONLY for applications requiring low speed operation with heavy loads.

Setting too LOW: Motor/Cylinder cogging at low speeds
Setting too HIGH: Erratic, jerky cylinder motion

e. SENS: (Sensitivity Gain) Single turn potentiometer which sets the system bandwidth, determining how close the actual cylinder position (0-5VDC Linear Pot Feedback) must be to the commanded position (External Command Signal) before the control will stop the cylinder.

Rotation CW Increases Sensitivity
CCW Decreases Sensitivity

Note 1: Large sensitivity gain provides small position hysteresis, a minute change in reference voltage will cause the cylinder to change position.

Note 2: Low sensitivity gain provides large position hysteresis, the difference in reference voltage must be larger before there is a position change.

Setting too LOW: Slow response, low system bandwidth
Setting too HIGH: Unstable, oscillatory operation

f. DECEL: (Deceleration Distance) Single turn potentiometer which sets the distance prior to stopping from which to begin deceleration from the main move velocity to the final move speed.

Rotation CW Increases Deceleration Distance
CCW Decreases Deceleration Distance

Note 1: Maximum distance setting prior to stopping at a final position can be up to 25% of the stroke length.

Setting too LOW: Cylinder overshoots position
Setting too HIGH: Cylinder takes an excessive amount of time for unit to creep into position.

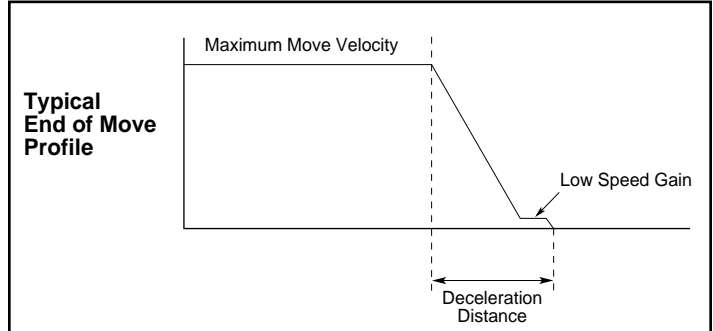

g. EX-L: (Extend End of Travel) Single turn potentiometer which sets the limit of travel in the extend direction. The pot sets the distance(limit) from the physical EXTEND end of travel.

Rotation CW Increases Distance from Extend End of Stroke
CCW Decreases Distance from Extend End of Stroke

Note 1: Potentiometer clamps feedback voltage from the linear pot, preventing full extend travel.

Note 2: Potentiometer can adjust up to 30% of stroke from the physical extend end of travel.

Setting too LOW: NO "end of travel" protection
Setting too HIGH: Reduced overall travel distance

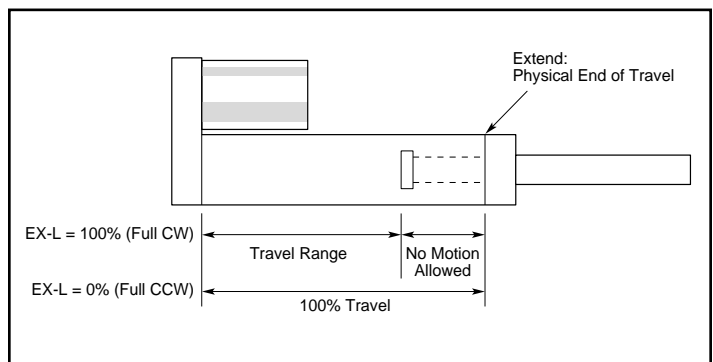

Chapter 1 Control Hardware

h. RT-L: (Retract End of Travel) Single turn potentiometer which sets the limit of travel in the retract direction. The pot sets the distance (limit) from the physical RETRACT end of travel.

Rotation CW Increases Distance from retract End of Stroke
 CCW Decreases Distance from retract End of Stroke

Note 1: Potentiometer clamps feedback voltage from the linear pot, preventing full retract travel.
Note 2: Potentiometer can adjust up to 30% of stroke from the physical retract end of travel.

Setting too LOW: NO "end of travel" protection
 Setting too HIGH: Reduced overall travel

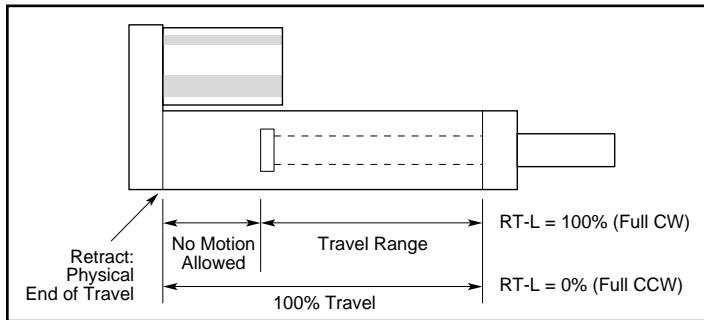

i. SCALE: Single turn potentiometer which sets the maximum command signal level equivalent to full cylinder extension. The pot scales (converts) the external command signal wired into the Reference Input into an internal 0 to 5 VDC signal for comparison with the 0 to 5 VDC feedback signal from the linear pot.

Rotation CW Increases Scaling Factor
 CCW Decreases Scaling Factor

External Reference	Setting
0 - 5 VDC (analog)	Full CCW (Not Used)
0 - 10VDC (analog)	Half a Turn
4 - 20ma (PID)	Approx. one half turn (see 4-20 ma Setup and operation)

Note 1: Scale pot used ONLY when operating with an external command signal on the Reference Input (Term #16, TB2) which is NOT 0 - 5VDC.
Note 2: Dipswitch #1 must be ON to enable the Reference Input(Term. #16, TB2) and the SCALE potentiometer.
Note 3: Output of the scale pot circuitry (Term #17, TB2) can be used as a test point to measure the internal scaled Command Signal level when the Reference Input(Term #16, TB2) is used.

Setting too LOW: Reduced overall travel length
 Setting too HIGH: _____

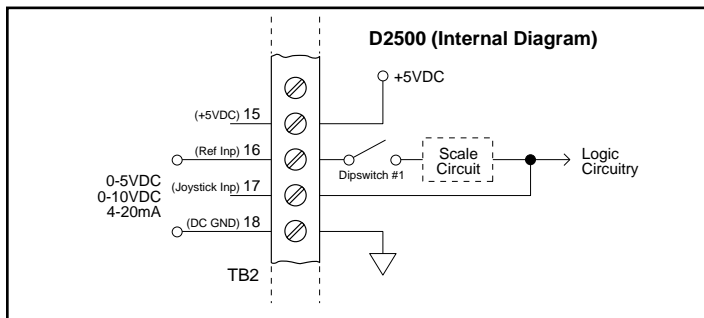

j. OFFSET: Single turn potentiometer used for providing an offset bias voltage when an external 4-20ma command signal is used. Sets the minimum command signal current level equivalent to full cylinder retraction.

Rotation CW Increases Offset Bias
 CCW Decreases Offset Bias

Note 1: Used ONLY when a 4-20 ma command signal is used.

Note 2: Dipswitch #3 must be on to enable the OFFSET Pot

Note 3: The offset adjustment enables a 4ma input to produce an internal 0 VDC reference command. Without the adjustment, 4ma would produce a 2 VDC signal as a minimum internal voltage reference which would result in a 20% cylinder extension as the minimum stroke.

Setting too LOW : Reduced overall travel length
 Setting too HIGH: _____

2. LED Indicators

Three LED Indicators are available to the user to monitor system operation.

1. Stall Detect LED

Location: Top Board
 Color: RED

Function: OFF during Normal Operation
 ON when a motor stall condition is detected

Note 1: Once ON, the LED will remain set until the command signal is reversed, power is cycled, the STOP input is momentarily (20ms) activated, or the disable input is momentarily (20ms) activated.

2. IN-POSITION LED

Location: Top Board
 Color: GREEN

Function: OFF during any motion, if no move has been initiated, or the cylinder has not stopped within the set final position bandwidth at the end of a move.

ON after a move is completed successfully (linear feedback signal is within the bandwidth of the commanded signal).

Note 1: Once ON, the LED will remain set until another move is attempted, the drive is reset with the stop or disable input, or power is cycled.

Note 2: If the LED is flickering On & Off; this indicates that the cylinder is hunting (oscillating) about a given setpoint. This condition will occur if the system gain is set too high. (system gain is set by the SENSitivity & LOW speed pots)

3. Current Sense LED

Location: Bottom Board
 Color: RED

Function: OFF when no power is going to the motor; this will occur when the motor is at standstill before or after a move or the motor has stopped due to a stall condition.

ON when power is going to the motor.



Chapter 1 Control Hardware

3. Dipswitches (1-4)

* Four dipswitches are available to configure the control to accept different types of command signal interfaces.

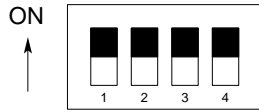

Dipswitch Reference Chart

Command Signal Input	Dipswitches			
	#1	#2	#3	#4
IDC Joystick	Off	Off	Off	Off
0-5VDC Analog	On	Off	Off	Off
1-10VDC Analog	On	Off	Off	Off
4-20 ma current	On	On	On	Off

* Dipswitch 4 MUST be OFF for normal operation

Dipswitch 1

ON: Enables the REFERENCE INPUT (Terminal 16, TB2) to receive an external command signal.

Note 1: The D2500 Series Controls are shipped from the factory with a Joystick Slide Pot prewired to the JOYSTICK INPUT for initial testing & setup of the control. When a remote signal is to be used, the Joystick is disconnected and the remote signal is wired into the REFERENCE INPUT.

OFF: Disables the Reference Input

Dipswitch 2

ON: Allows 4-20ma to be used as the command signal on the REFERENCE INPUT.

Note 1: Enables circuitry to perform current to voltage conversion on the reference input.

Note 2: Used only with a 4-20ma command signal

OFF: Disables reference input for use with a 4-20ma signal; allowing an analog voltage source only as a command signal.

Dipswitch 3

ON: Enables the OFFSET POT for use when operating the control with a 4-20ma command signal.

Note 1: Used ONLY with a 4-20ma command signal

OFF: Disables OFFSET POT

Dipswitch 4

ON: Reserved

OFF: NORMAL OPERATION

4. RUN/JOG Jumper, Fuse, and Joystick Slide Pot

Run/Jog Jumper

Single jumper located on the bottom board which allows user to select the RUN or JOG MODE of operation. This jumper **MUST** be in the Jog Mode (*Center & Top pins jumpered*) for proper D2500 operation. All D2500 controls are set for the jog mode of operation before leaving the factory.



Fuse

A single fuse comes with the D2501 & D2502 Models ONLY. It is located on the control chassis and is used to protect the power supply from excessive current draw.

Ratings: 120 VAC Operation; 250VAC @ 2amp, Type AGC 2
230 VAC Operation; 250VAC @ 1amp, Type AGC 1

Joystick Slide Pot (Prewired to the control at the factory)

A 10K ohm external slide potentiometer is provided by IDC for initial testing of the D2500 System. Supplied 5 volts from the control, the wiper arm of the slide pot provides a 0-5VDC command signal to the JOYSTICK INPUT as it is manually moved.

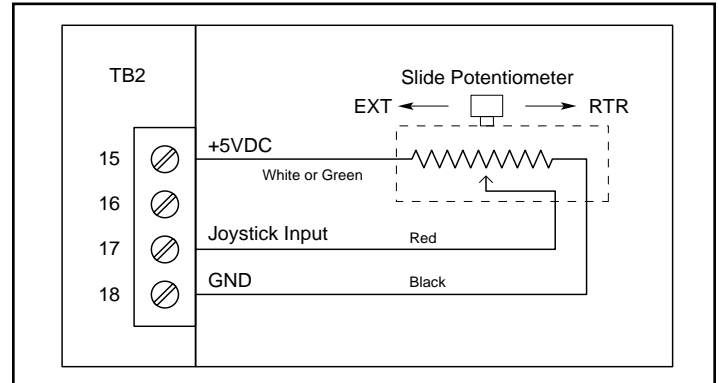

Note: When a remote command signal is used, the Joystick Pot should be disconnected from the control and the remote signal wired to the Reference Input.



Chapter 2 Wiring Diagrams & I/O Descriptions

D2500 System Block Diagram

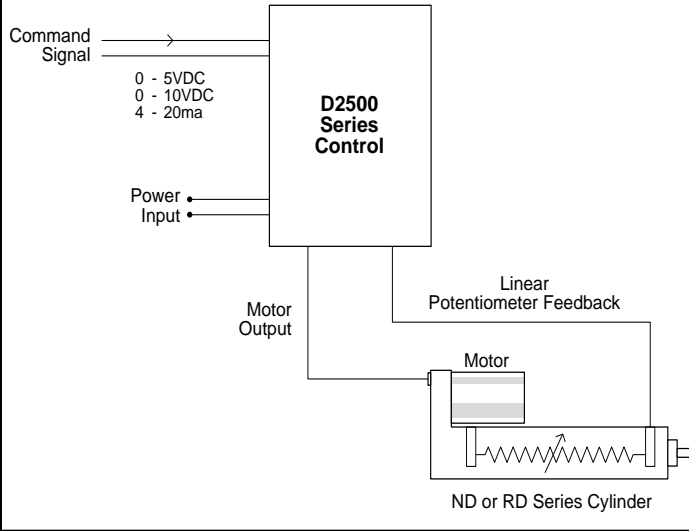

B. Power Supply Wiring

Model D2500

*Supply +24 VDC (@ 10 amps max.) to the bottom circuit board to terminal strip TB1; connect +24VDC to Terminal 2 (+24VDC) and connect DC Supply Ground to Terminal 1 (GND).

Models D2501 & D2502

*Supply 115VAC (@ 2 amps max) or 230VAC (@ 1 amp max.) to the L1 & L2 Terminal inputs on the supplied transformer.

D2501 & D2502 controls are prewired from the factory for 115VAC input

- 115 VAC
 - Jumper transformer leads 1 & 3 and 2 & 4 (Prewired at IDC)
 - Wire the 115 VAC input to terminals L1 & L2
 - Secure Ground Line to chassis ground screw
- 230 VAC
 - Jumper transformer leads 2 & 3
 - Transformer lead 4; no connection
 - Transformer lead 1, tied to fuse block
 - Wire the 230 VAC input to terminals L1 & L2
 - Secure Ground Line to chassis ground screw

A. Terminal Listings

TB1 10 Pin Terminal Strip

Term. #	Label	Description	
1	GND	External Supply Input: DC Ground	Power Supply
2	+24V	External Supply Input: +24V DC	
3	M-	Motor Negative Terminal	Motor Output
4	M+	Motor Positive Terminal	
5	COM	DC Ground	Stop input
6	—	Reserved	
7	—	Reserved	
8	Stop	Stop Input	
9	—	Reserved	
10	—	Reserved	

TB2 12 Pin Terminal Connector

Term. #	Label	Description	
11	+5v	Linear Pot: +5V DC Power Supply	Linear Pot Fdbk
12	LPO-1	Linear Pot: Wiper Input	
13	GND	Linear Pot: DC Ground	
14	GND	DC Ground	
15	+5v	+5V DC Power Supply	Joystick/Ext. Ref. Input
16	REF INP	External Reference Input	
17	Joystick INP	External Joystick Input	
18	GND	DC Ground	
19	Stall Out	Stall Output	Stall & IN POS Outputs
20	IN POS Out	In Position Output	
21	Disable +	Disable Input Positive	Disable Input
22	Disable -	Disable Input Negative	

* Note: Terminals 1, 5, 13, 14, & 18 are internally tied to DC Common.

115VAC

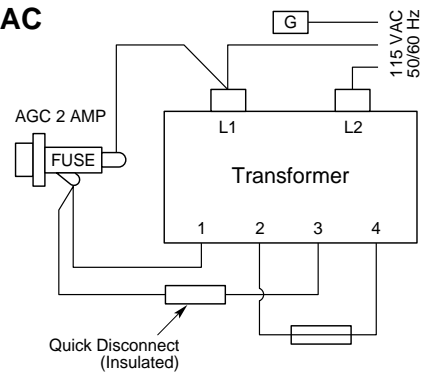

230VAC

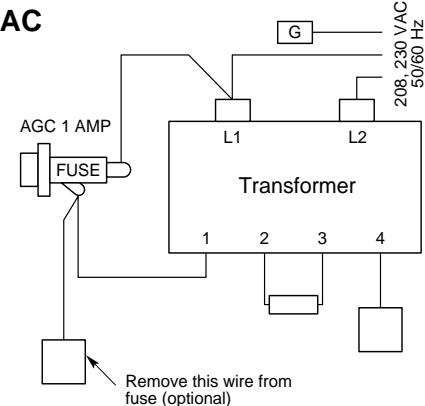

* The D2501 & D2502 models contain an integral Power Supply built into the chassis housing which supplies +24V DC to the circuit boards. The red wire from the power capacitor ("+" Terminal) is connected to Terminal 2 (+24VDC) on connector TB1. A black wire from the capacitor ("- Terminal) is connected to Terminal 1 (GND).



Chapter 2 Wiring Diagrams & I/O Descriptions

C. Motor Wiring

D2500 Controls are designed to be used with STANDARD & INLINE D Series Motors to control cylinder motion. Both motors are permanent magnet, two pole DC motors rated for 24VDC @ 5 amps continuous and 10 amps peak.

Terminal (TB1)	Label	Color Code (Standard)	Quick Disconnect (QF1-6, QF1-12)
3	M-	Black	Black
4	M+	Red	White
			Green (No Connection)

Cylinders with 12 to 1 gear ratios or reverse/parallel motor mounts need to have the M+ and M- terminal connections reversed to allow a positive going command signal to extend the cylinder.

The following table indicates which cylinder models require lead reversal;

Motor/Orientation	Models Affected
Standard Motor Parallel Mount	ND1208A, ND1205A, ND1205B RD1208A, RD1205A, RD1205B
Standard Motor Reverse Parallel Mount	All Except ND1208A, ND1205A, ND1205B RD1208A, RD1205A, RD1205B
Inline Motor Parallel Mount	All Except ND1208A, ND1205A, ND1205B RD1205A, RD1208A, RD1205B
Inline Motor Reverse Parallel Mount	ND1208A, ND1205A, ND1205B RD1208A, RD1205A, RD1205B

Reference 1: Standard & Inline D Series Motors: A complete listing of motor specifications are listed in [Appendix B](#).

Reference 2: More Information on Cylinder Models & Motor Orientation See [Appendix C](#)

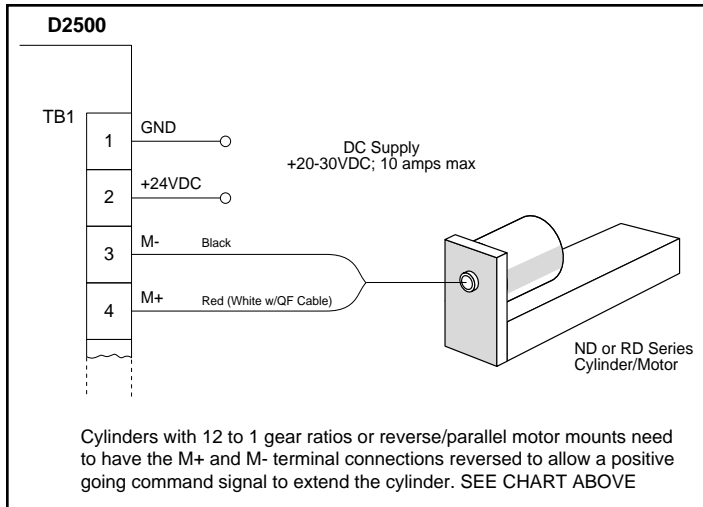

D. Linear Potentiometer Feedback and the Command Signal

Linear Potentiometer Feedback: The linear potentiometer resides within the cylinder housing and is energized by a +5 volt supply from the D2500; Term#11 (+5vdc) and Term#13 (GND). The wiper arm of the pot moves in conjunction with the cylinder thrust tube or carriage assembly, providing a 0-5 vdc analog feedback signal to the control on Term#12 (LPO-1), which is proportional to the linear stroke displacement.

External Command Signal: The D2500 Control accepts an external analog voltage or current command signal which represents the desired proportional linear position of the electric cylinder. Two control inputs are available to the user to enter the command signals to test and operate the D2500 System.

- Joystick Input:** The JOYSTICK INPUT accepts a 0-5vdc command signal from the 10K ohm external Joystick Slide Pot (Prewired to the control at the factory) which is provided by IDC for initial testing of the D2500 System. The pot is energized by a +5vdc supply from the control, Term #15 (+5vdc) and Term #18 (GND). When the slide pot is moved, the wiper output provides a proportional 0-5vdc command voltage to the control, Term #17(Joystick Input).
- Reference Input:** The REFERENCE INPUT accepts an analog voltage of (0-5vdc, 0-10vdc) or a current command input of 4-20ma from a remote device such as a PLC or a Computer with an I/O Card. The command signal is wired to the control on Term#16 (Ref Inp) and Term#18 (GND).

Note 1: Dipswitch #1 must be turned on to enable this input.

NOTE: ONLY one of the above control inputs (Joystick or Reference Input) may be used at any one time to accept an external command signal.

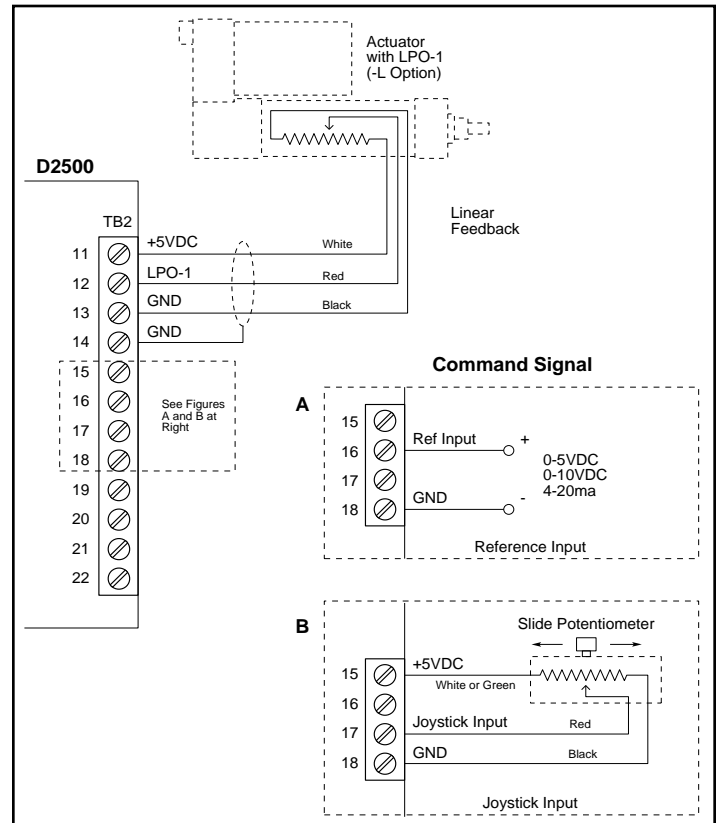

Chapter 2 Wiring Diagrams & I/O Descriptions

E. STOP and DISABLE Inputs

STOP Input: Low voltage sinking input which disables current going to the motor. NO cylinder motion will be allowed when the input is activated & maintained.

Momentary activation of the Stop Input is also used to reset the control when a stall condition is detected. Input must be maintained for 20ms to be recognized.

Note: When the Stop Input is released, the cylinder will move to the position determined by the command signal.

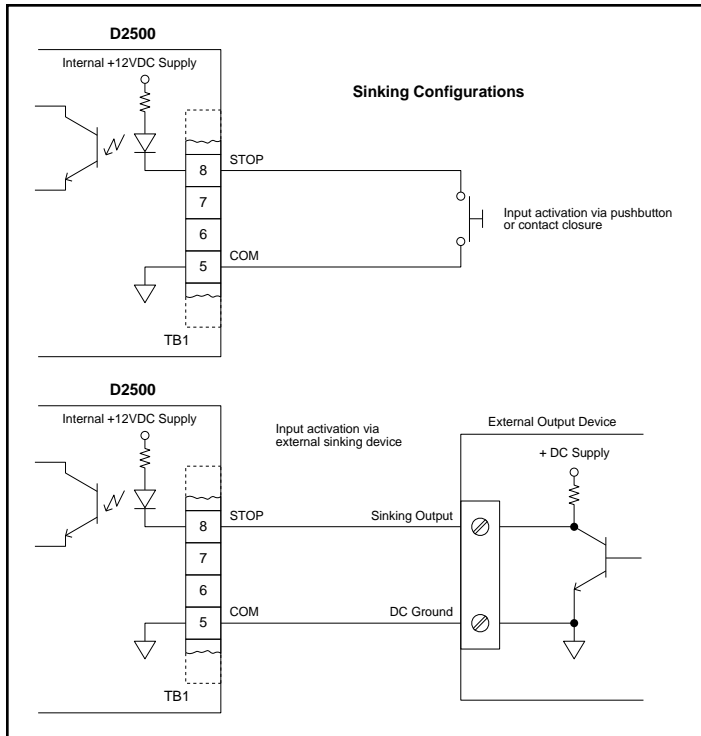

Disable Input: Optically-isolated, sinking or sourcing input

Disable Input performs the exact same operations as the STOP Input listed above

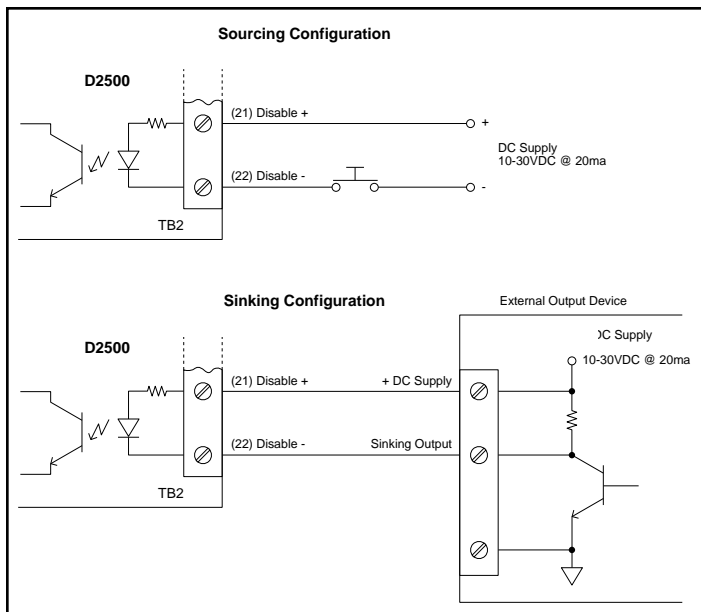

F. STALL and IN POSITION OUTPUTS

STALL Output: Open collector, sinking output which activates when the cylinder experiences a stall condition.

OFF (Open Circuit High) During normal operation
ON (Sinking to Ground) When a stall condition is detected

Note 1: Once activated the output will remain set until the drive is reset.

IN POS Output: Open Collector sinking output which activates after a move is completed successfully (when the linear feedback signal is within the bandwidth of the commanded signal).

OFF (Open Circuit High) During any move execution, no move has yet been initiated, or if the cylinder has not successfully completed its move.

ON (Sinking to Ground) If the cylinder has successfully completed its move.

Note: Once active, the output will remain set until a new move begins, the drive is reset, or power is cycled.

The STALL and IN POSITION Outputs may be wired in either of the sinking configurations shown below.

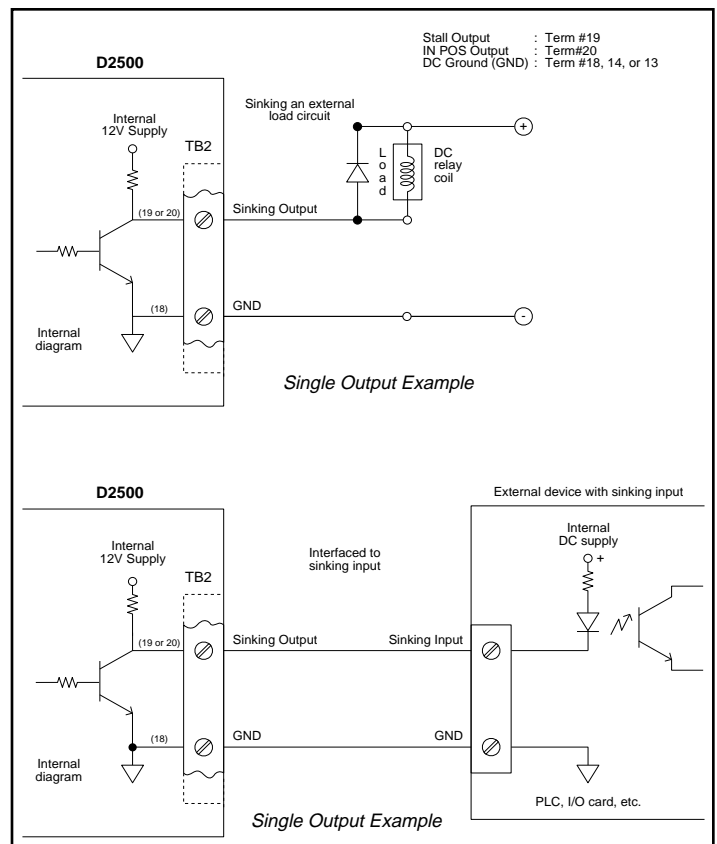

Chapter 3 Setup and Operation

A. Operating Principles

From the Factory...

All D2500 controls are shipped from the factory with an external Joystick Slide Pot prewired to the Joystick Input on the control. Supplied power from the control, the pot provides a 0-5VDC Command Signal as the slide pot is manually moved forward and back. This slide pot is included for initial testing and setup of the control and should be removed when the remote command signal is wired to the REFERENCE INPUT.

The Command Signal...

The D2500 accepts a remote analog voltage (0-5VDC, 0-10VDC) or a current command (4-20 ma) on the REFERENCE INPUT of connector TB2. This command signal is translated by the control into a proportional linear position on a D or RD Series Electric Cylinder.

Note 1 : The REFERENCE INPUT is configured for a command signal type via the dipswitch settings.

Note 2 : The Command Signals of 0-10VDC & 4-20ma are internally scaled down to 0-5VDC by the scale pot to allow for direct comparison to the 0-5VDC linear pot feedback signal.

The Linear Potentiometer Feedback...

The linear feedback pot which resides in the cylinder housing is energized by a 5VDC supply from the control. As the cylinder "thrust tube" moves, the wiper of the linear pot provides a 0-5VDC analog feedback signal to the control which is proportional to cylinder position. (0VDC = Full Retraction, 5VDC = Full Extension)

The Move...

The cylinder will begin a move when there is a difference in voltage between the the command signal and the feedback voltage. Each move begins at a speed determined by the "High" speed pot setting. As the cylinder nears its commanded position, the cylinder decelerates to a creep speed before stopping at the final position.

NOTE 1: If the difference between the feedback and the command signal is small, the cylinder will simply creep into position.

The distance prior to stopping, where deceleration occurs, is set by the "Decel" pot, the power of the motor as it creeps into position is set by the "Low" speed gain pot, and the "Sens" pot determines how close the feedback signal must be compared to the command signal level before the cylinder is considered IN POSITION.

Summary. . .

The D2500 Series Controls accept an analog or current command input, internally scales it down to 0-5VDC, and translates the scaled signal into a proportional linear displacement on a Rod or carriage assembly on a D Series Electric Cylinder with a linear potentiometer option.

The translation is accomplished when a command signal from a remote device is received on the REFERENCE INPUT, the control compares the scaled command signal to the analog position feedback from the linear potentiometer within the cylinder housing. If there is a difference, the cylinder will be commanded to move until the feedback from the pot is equivalent to the scaled command input.

B. System Setup

The following sections describe the setup of the D2500 controls when using the different command signal types. These setup procedures should be performed on an unloaded cylinder to first ensure proper functionality and operation of your D2500 Series/Cylinder System. When the basic operation is assured, you may connect the cylinder to the load and fine tune the system for optimum performance. The following table provides a "Quick Reference Guide" for the tuning pots to help guide the user to obtain the desired system performance.

Potentiometer Settings

(All potentiometers are single return rotation)



Full CCW
0%



1/2 Turn
50%



Full CW
100%

Potentiometer Functions: QUICK REFERENCE GUIDE

- Current Sense:** Sets the current threshold which determines the allowed current draw to the motor, dictating the cylinders thrust potential and stall threshold.
- High:** Sets the cylinders main move velocity
- Low:** Sets the low speed gain for the motor when the cylinder decels into its final creep speed prior to stopping.
- IR:** Sets the current regulation of the motor when the cylinder is traveling at low speeds with heavy loads.
- Sens:** Sets the system bandwidth, determining how close the feedback signal must be to the commanded signal before the cylinder is considered IN POSITION.
- Decel:** Sets the distance prior to stopping from which the cylinder will begin deceleration from the main move velocity to the final move speed.
- EX-L:** Sets the limit of travel in the Extend Direction.
- RT-L:** Sets the limit of travel in the Retract Direction.
- Scale:** Scales the Command Signal on the Reference Input down to 5VDC (internally). Used only with command signals which are not 5VDC (0-10VDC, 4-20ma)
- Offset:** Provides an internal voltage bias, allowing 4ma command signal to be equal to 0% cylinder extension. (Used only when the Command Signal is 4-20ma)



Chapter 3 Setup & Operation

1. Joystick Slide Pot

WIRING

1. Wire Power per CHAPTER 2, SECTION B
2. Wire Motor per CHAPTER 2, SECTION C
3. Wire Linear Feedback Pot per CHAPTER 2, SECTION D
4. Wire the Joystick Slide Pot Command Signal to the Joystick Input per CHAPTER 2, SECTION D

INITIAL SETTINGS

1. RUN/JOG JUMPER is set for JOG
2. Dipswitches #1 #2 #3 #4 are OFF
3. Potentiometer Settings

Current Sense: 50%	DECEL: 25%
HIGH: 75%	OFFSET: Not Used
LOW: 50%	SCALE: Not Used
IR: 0%	RT-L: 0%
SENS: 25%	EX-L: 0%

Determine if your CYLINDER is following the JOYSTICK SLIDE POT where full extension of the Joystick Slide Pot equals full extension of the cylinder (100% stroke) and full retraction of the slide pot is equal to full retraction of the cylinder (0% stroke).

1. Manually slide the Joystick Slide Pot to Mid Position.
2. Apply POWER to the control

WARNING: the cylinder rod will extend from its fully retracted position.

The cylinder rod should now move to MID-STROKE

3. Turn the "LOW" Speed Gain pot CW until the IN POSITION (GREEN LED) turns ON. (If the LED has already turned ON, leave current setting)

SET UP END OF TRAVEL PROTECTION

1. Slowly extend the Joystick Slide Pot(Extend side of pot is determined by the location of the White(or Green) wire on the underside of the pot) to its maximum extend travel. The cylinder will follow the command signal, extending until it meets the EXTEND PHYSICAL END OF TRAVEL (HARD STOP).
2. Turn the EX-L pot CW until the cylinder retracts off of the HARD STOP. This setting will determine the maximum extend distance the cylinder may travel.
3. Slowly retract the Joystick Slide Pot(RETRACT side of pot is determined by the location of the BLACK wire on the underside of the pot) to its maximum extend travel. The cylinder will follow this command signal, retracting until it meets the RETRACT PHYSICAL END OF TRAVEL(HARD STOP).
4. Turn the RT-L pot CW until the cylinder extends off of the HARD STOP. This setting will determine the minimum retract distance the cylinder may travel.

SYSTEM SETUP IS OPERATIONAL

2. 0-5 VDC Analog Input

WIRING

1. Wire Power per CHAPTER 2, SECTION B
2. Wire Motor per CHAPTER 2, SECTION C
3. Wire Linear Feedback Pot per CHAPTER 2, SECTION D
4. Wire the Command Signal to the Reference Input per CHAPTER 2, SECTION D

INITIAL SETTINGS

1. RUN/JOG JUMPER is set for JOG
2. Dipswitches: #1 ON, #2 #3 #4 are OFF
3. Potentiometer Settings

Current Sense: 50%	DECEL: 25%
HIGH: 75%	OFFSET: Not Used
LOW: 50%	SCALE: 0%
IR: 0%	RT-L: 0%
SENS: 25%	EX-L: 0%

Determine if your CYLINDER is following the 0-5VDC Analog Input where 5VDC is full cylinder extension(100% stroke) and 0VDC is full retraction (0% stroke).

1. Apply POWER to the control
2. Provide a COMMAND SIGNAL OF 2.5VDC.

WARNING: the cylinder rod will extend from its fully retracted position.

The cylinder rod should now move to MID-STROKE.

3. Turn the "LOW" Speed Gain pot CW until the IN POSITION (GREEN LED) turns ON. (If the LED has already turned ON, leave current setting)

SET UP END OF TRAVEL PROTECTION

1. Slowly increase the command signal to 5vdc, the cylinder will follow the command signal, extending until it meets the EXTEND PHYSICAL END OF TRAVEL(HARD STOP).
2. Turn the EX-L pot CW until the cylinder retracts off of the HARD STOP. This setting determines the maximum extend distance the cylinder may travel.
3. Slowly decrease the command signal to 0vdc, the cylinder will follow this command signal, retracting until it meets the RETRACT PHYSICAL END OF TRAVEL(HARD STOP).
4. Turn the RT-L pot CW until the cylinder extends forward off of the HARD STOP. This setting determines the minimum retract distance the cylinder may travel.

SYSTEM SETUP IS OPERATIONAL, attach load to the cylinder and fine tune the system for optimum performance.



Chapter 3 Setup & Operation

3. 0-10 VDC Analog Input

WIRING

1. Wire Power per CHAPTER 2, SECTION B
2. Wire Motor per CHAPTER 2, SECTION C
3. Wire Linear Feedback Pot per CHAPTER 2, SECTION D
4. Wire the Command Signal to the Reference Input per CHAPTER 2, SECTION D

INITIAL SETTINGS

1. RUN/JOG JUMPER is set for JOG
2. Dipswitches: #1 ON, #2 #3 #4 are OFF
3. Potentiometer Settings

Current Sense: 50%	DECEL: 25%
HIGH: 75%	OFFSET: Not Used
LOW: 50%	SCALE: 50%
IR: 0%	RT-L: 0%
SENS: 25%	EX-L: 0%

SCALE the 10 Volt Command Signal

1. Temporarily Disconnect the motor leads from the control.
2. Apply power to the control
3. Provide a COMMAND SIGNAL of 10VDC to the REFERENCE INPUT.
4. Place a VOLTMETER (0-10VDC Scale) across the output of the Scale Pot test point. Place the positive lead on TERM#17 (Joystick Input) and the negative lead on TERM#18 (GND).
5. Turn the SCALE POT CW until the voltage reads 5VDC. (This scales the 10VDC command input to 5VDC)
6. Unplug power to the control and reconnect the motor.

Determine if your CYLINDER is following the 0-10VDC Analog Input where 10VDC is full cylinder extension(100% stroke) and 0VDC is full retraction(0% stroke).

1. Apply POWER to the control
2. Provide a COMMAND SIGNAL of 5VDC to the REFERENCE INPUT.

WARNING: the cylinder rod will extend from its fully retracted position.

The cylinder rod should now move to MID-STROKE.

3. Turn the "LOW" Speed Gain pot CW until the IN POSition (GREEN LED) turns ON. (If the LED has already turned ON, leave current setting)

SET UP END OF TRAVEL PROTECTION

1. Slowly increase the command signal to 10vdc, the cylinder will follow the command signal, extending until it meets the EXTEND PHYSICAL END OF TRAVEL (HARD STOP).
2. Turn the EX-L pot CW until the cylinder retracts off of the HARD STOP. This setting determines the maximum extend distance the cylinder may travel.
3. Slowly decrease the command signal to 0vdc, the cylinder will follow this command signal, retracting until it meets the RETRACT PHYSICAL END OF TRAVEL (HARD STOP).
4. Turn the RT-L pot CW until the cylinder extends forward off of the HARD STOP. This setting determines the minimum retract distance the cylinder may travel.

SYSTEM SETUP IS OPERATIONAL, attach load to the cylinder and fine tune the system for optimum performance.

4. 4-20ma Current Input

WIRING

1. Wire Power per CHAPTER 2, SECTION B
2. Wire Motor per CHAPTER 2, SECTION C
3. Wire Linear Feedback Pot per CHAPTER 2, SECTION D
4. Wire the Command Signal to the Reference Input per CHAPTER 2, SECTION D

INITIAL SETTINGS

1. RUN/JOG JUMPER is set for JOG
2. Dipswitches: #1 #2 #3 ON, #4 OFF
3. Potentiometer Settings

Current Sense: 75%	DECEL: 25%
HIGH: 75%	OFFSET: 0%
LOW: 25%	SCALE: 50%
IR: 0%	RT-L: 0%
SENS: 0%	EX-L: 0%

SCALE the 4-20ma Command Signal & Determine if your CYLINDER is following the 4-20ma Current Input where 20ma is full cylinder extension (100% stroke) and 4ma is full retraction(0% stroke).

1. Apply POWER to the control
2. Provide a COMMAND SIGNAL of 20ma to the REFERENCE INPUT.

WARNING: the cylinder rod will extend from its fully retracted position.

- The cylinder rod should now move to 70-80% FULL STROKE.
3. Turn the "LOW" Speed Gain pot CW until the IN POSition (GREEN LED) turns ON. (If the LED has already turned ON, leave current setting)
 4. Adjust the SCALE Pot until the cylinder moves into the desired extend position. (CCW: Extends Cylinder CW:Retracts Cylinder)
 5. Provide a Command Signal of 4ma to the REFERENCE INPUT.
 6. Adjust the OFFSET Pot until the cylinder moves into the desired retract position. (CCW: Extends Cylinder CW:Retracts Cylinder)
 7. Reapply a Command Signal of 20ma to the REFERENCE INPUT.
 8. Repeat procedures 4-7 until both positions are correct.
- Note: Since the Scale and Offset Pots interact with one another it is necessary to repeat the above procedures until the settings allow both end positions.*

SET UP END OF TRAVEL PROTECTION

1. Slowly increase the command signal to 20ma, the cylinder will follow the command signal, extending until it meets the setpoint determined by the SCALE POT.
2. Turn the EX-L pot CW until the cylinder begins to retract. This setting determines the maximum extend distance the cylinder may travel.
3. Slowly decrease the command signal to 4ma, the cylinder will follow the command signal, retracting until it meets the setpoint determined by the OFFSET POT.
4. Turn the RT-L pot CW until the cylinder begins to extend. This setting determines the minimum retract distance the cylinder may travel.

SYSTEM SETUP IS OPERATIONAL, attach load to the cylinder and fine tune the system for optimum performance.



Chapter 4 Appendices

Appendix A Linear Potentiometer Option (-L-)

*The linear potentiometer resides within the cylinder housing and is energized by a +5VDC supply from the D2500 Control. The potentiometer wiper arm moves in conjunction with the cylinder thrust tube or carriage assembly, providing an analog feedback signal to the control proportional to the linear stroke displacement. (ex. 0 VDC = 0% stroke, 2.5 VDC = 50% stroke, & 5 VDC = 100% stroke)

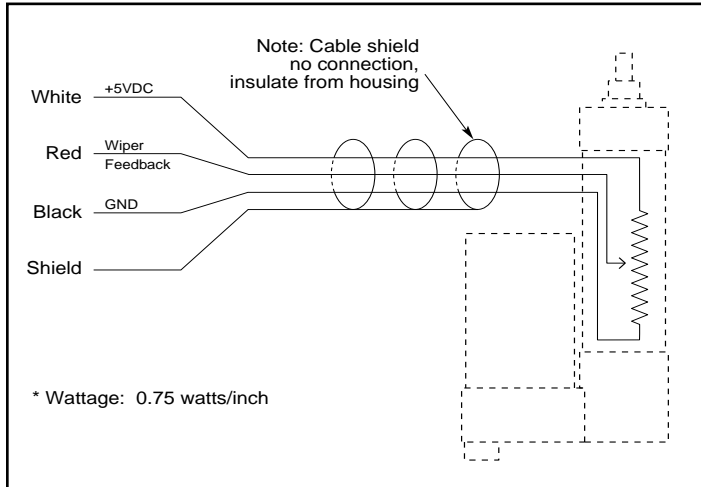

LPO Length (inches)	IDC P/N	Resistance (ohms)	Linearity (%)
2"	LP-02	0 - 3000 ohms +/- 30%	+/- 1%
4"	LP-04	0 - 6000 ohms +/- 30%	+/- 1%
6"	LP-06	0 - 9000 ohms +/- 30%	+/- 1%
8"	LP-08	0 - 9000 ohms +/- 30%	+/- 1%
12"	LP-12	0 - 5000 ohms +/- 20%	+/- 1%
18"	LP-18	0 - 5000 ohms +/- 20%	+/- 1%

Appendix B D Series Motors

TYPE: Permanent Magnet 2 pole DC Motors, 2 Lead

RATINGS	STANDARD	INLINE
Voltage	24 VDC, 36 VDC Max	24VDC, 30 VDC Max
Current	4.5 Amps cont, 10 Amps peak	4.5 Amps cont, 10 Amps peak
Torque	40 oz-in	40 oz-in
Kt(Torque Constant)	8.9 oz-in/Amp +/-10%	8.8 oz-in/Amp +/-10%
No Load Speed	3600 rpm	3600 rpm
Windings		
Resistance	1.0 Ohm	0.7 Ohm
Inductance	2.0 mH	1.6 mH
Moment of Inertia	0.018 oz-in/sec ²	0.008 oz-in/sec ²
Cabling	Less than 50ft(16AWG), 50-100ft (14AWG), 100-200ft (10AWG)	
Brushlife	1,000,000 cycles/ 1000 hours	

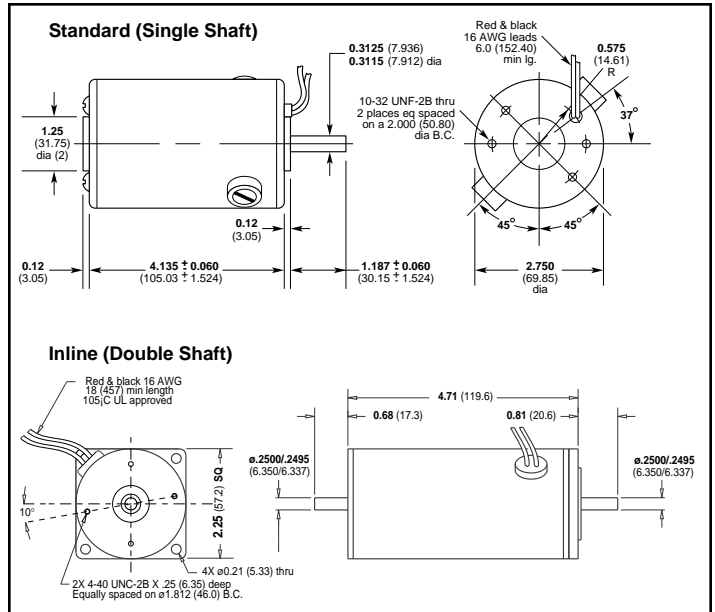

Appendix C ND & RD Series Cylinders

Available Linear Speeds Model Number: 3 or 4 Digit Code

Model	in/sec	Model	in/sec	Model	in/sec
D102	24.0	D105	10.0	D108	7.5
152	16.0	155	7.0	158	4.5
202	14.0	205	6.0	208	3.5
352	—	355	3.5	358	2.0
992	24.0	995	10.0	998	6.0
		1205	1.0	1208	.6

Ballscrew 2 pitch Acme/Ballscrew 5 pitch Acme 8 pitch

Final move speeds are **LOAD & LENGTH DEPENDENT**

Note 1: The 3 or 4 digit code on the Cylinder label indicates the system model number and specifies the Gear Ratio and Screw Pitch.

Note 2: Linear Speeds are based on a max. Motor Speed of 3600 RPM for the Standard D Motor and 3450 RPM for the Inline D Motor.

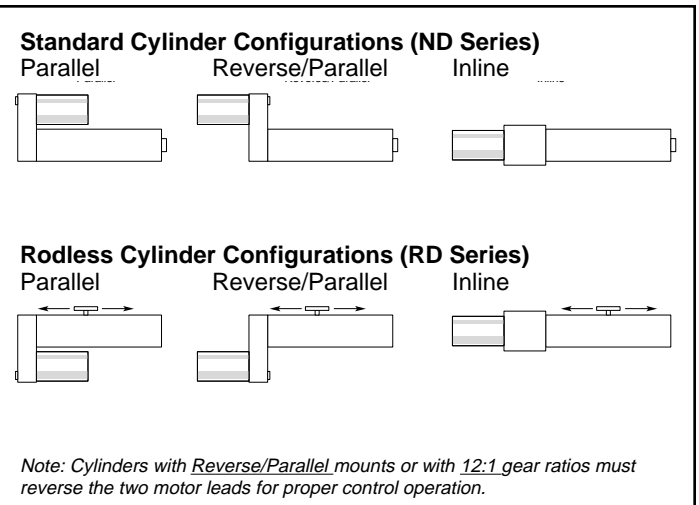

Chapter 4 Appendices

Appendix D. Troubleshooting

Symptoms	Cause	Remedy
Cylinder Overshooting Position	Speed set too high Decel Distance set too low	Reduce "HIGH" Speed Pot (CCW) Increase "DECEL" Pot (CW)
Cylinder Oscillates about the Stop Position (IN POS LED flickers)	System Gain Set too high	Reduce "LOW" Speed Gain (CCW) Reduce "SENS" Setting (CCW) Increase "DECEL" Distance (CW)
Cylinder DOES NOT achieve Final Position (IN POS LED does not come ON at the end of a move)	Not enough Motor Power to move load at low speed	Increase "LOW" Speed Gain (CW) Increase "SENS" Setting (CW)
Slow System Response	Speed setting too low Decel Distance too large	Increase "HIGH" Speed (CW) Reduce "DECEL" Distance (CCW)
Reduced Overall travel Length	Setup & Scaling for given Command Signal incorrect End of Travel Limit setting is incorrect	Review SETUP & OPERATION for Command Signal being used Reduce "EX-L" Setting (CCW) for extend distance or reduce "RT-L" for retract distance
Cylinder lunges to either Physical End of Travel when power applied	Linear Feedback Lost Polarity of Motor or the Linear Pot Wiring Reversed	Check cabling for Linear POT Check Resistance of Lin. Pot Check wiring for Motor & the Linear Pot
Stall LED comes ON frequently when a move is attempted	Current Sense Setting too low Cylinder/Load Binding Velocity set too high for given load Command Signal changing too rapidly	Increase "Current Sense" (CW) Check unloaded cylinder operation mechanical mounting of load Reduce "HIGH" Speed (CCW) Increase "SENS" setting (CW)
Cylinder Suddenly moves to the full retracted position	Command Signal Lost	Check wiring for command signal or for problems with the signal source
Cylinder doesn't Move	Power Off NO DC Power at Control Fuse Blown Speed setting too low STOP OR DISABLE INPUTS activated & maintained No Power to Motor	Check AC Power (D2501/D2502) Check for 24VDC at terminals 1 & 2 on TB1 Replace Fuse (D2501/D2502) Increase "HIGH" Speed (CW) Deactivate Inputs Check Motor Wiring



Warranty and Service Coverage

Industrial Devices Corporation warrants all products to be free of defects in workmanship for a period of one year from the date of shipment to the end user. Products returned prepaid to the factory will be repaired or replaced at our option at no charge, and returned prepaid to the user.

Products that have expended their useful life in less than one year or have been improperly used or damaged, in the opinion of the company, are not subject to the terms of this warranty.

Technical Support

Industrial Devices offers technical support through its factory authorized and trained Distributors, and through its factory-based Applications Engineering and Inside Sales department.

If an application problem exists or if the product has failed, contact your Distributor or Industrial Devices for technical assistance. Contact our factory at 800-747-0064, outside the U.S. at 707-789-1000.

Repair Service

Product repairs are performed at our factory in Novato, California. Prior approval by Industrial Devices is required before returning a product for any reason. All return packages must be accompanied by an Industrial Devices supplied RMA(Return Material Authorization) number.

In Case of Failure

1. Get the Model and Serial number of the defective unit, and document the nature of the failure using the RMA Data Form to help us repair the unit..
2. Prepare a purchase order for the repair cost in case the unit is out of warranty.
3. Contact your IDC Distributor or Industrial Devices Corporation (at 1-800-747-0064) for a Return Material Authorization RMA#. —Provide information describing the nature of the failure.
4. Ship the unit prepaid, with the RMA number and documentation to:

Industrial Devices Corporation
3925 Cypress Drive
Petaluma, CA 94954
Attn: RMA # _____



For More Information

If you require further information on D2500 Series Controls or another Industrial Devices product, please call your local IDC Distributor or Industrial Devices.

Local IDC Distributor

Company: _____

Contact: _____

Phone #: _____

To get quick response to specific information when calling Industrial Devices, ask for the area of expertise that relates to your question:

Technical Support?

Ask for Applications Engineering

Product Information, Availability, or Repairs?

Ask for Inside Sales

D2500 Series: General Wiring Diagram

CAUTION! Cylinders with 12 to 1 gear ratios or reverse/parallel motor mounts need to have the MOTOR connections reversed to allow a positive going command signal extend the cylinder. SEE CHART ON PAGE 8.

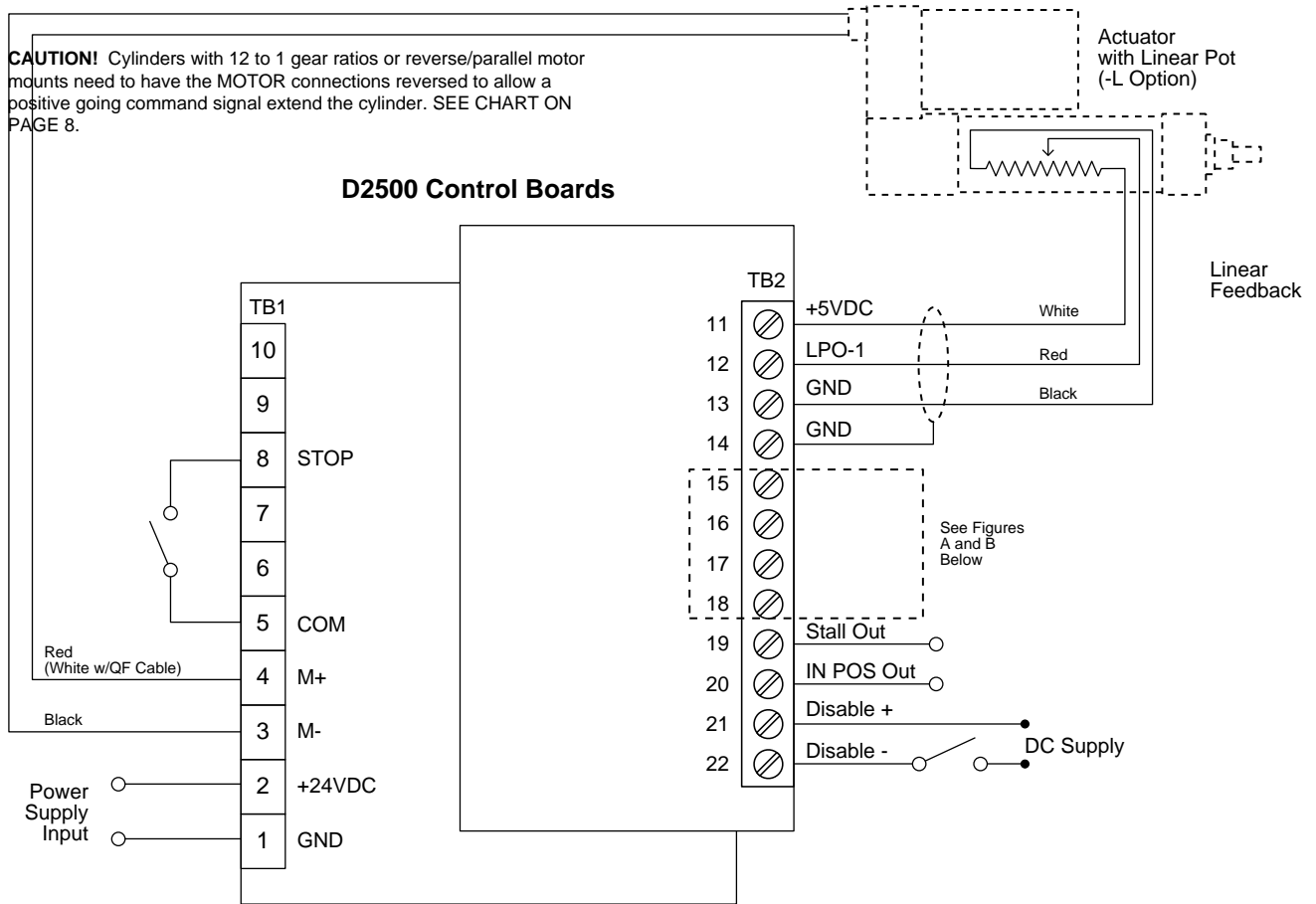

Command Signal

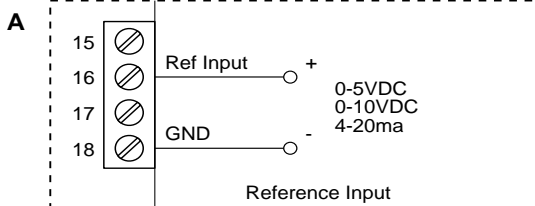

Command Signal

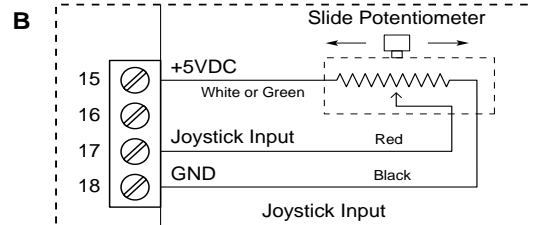

Industrial Devices Corporation, LLC • 3925 Cypress Drive • Petaluma, CA 94954

1-800-747-0064 • Outside U.S. 707-789-1000 • FAX 707-789-0175