

**OWNER'S INSTALLATION
AND OPERATING
MANUAL**

**M4000 SERIES
DIGITAL 3PHASE
DC Drives 5-1000 HP**

Detailed changes to software programs are introduced frequently. Please ensure this manual refers to the software version you are using.

**Danaher MOTION
Engineered Systems Center**

13500-J SOUTHPOINT BLVD. , CHARLOTTE,N.C. 28273
PHONE: (704)-588-5693; FAX: (704)-588-5695

For your safety and for proper operation, please take time to carefully read all instructions before installing and operating this unit.

LIM 55394-REV. G 6/01

Table Of Contents

Section	Page #
<i>How To Use This Manual</i>	3
Precautions	3
Quick Start	4
A. Chassis/Enclosed Diagram	5
B. Power Module Diagram	6
Features And Benefits	7
A. Power Module	7-9
B. Packaged Drives	10-14
Wiring Diagrams	15-16
Programming The Mentor II DC Drive	17
A. Menu Structure	17
B. Modes Of Operation	17
C. Description Of Keypad	18
D. Parameter Selection and Editing	18
E. Store (Save) Procedure	19
F. Security Access/Enable	19-20
G. Defaulting The Drive	20
H. Destination and Source Parameters	21-23
I. Threshold Parameters	24
Special Motor Considerations	24-26
Motor Field Supply Information and Set-Up Procedure	27
A. Motor Shunt Field	27
B. Motor Series Field	27
C. Motor Field Supply	28
D. MDA-3 Regulator Set-Up	28-30
E. Field Economy	30
F. FXM5	31-38
Feedback Selection and Setup	39
A. Armature Voltage Feedback	39
B. DC Tachometer Feedback	39-41
C. Encoder Feedback	42-44
Extended Speed Range (Field Weakening)	44-50
Reference Setup	51
A. Speed Potentiometer	51
B. Voltage Speed Reference	51
C. Current Speed Reference	51
D. Encoder Speed Reference	52
Initial Parameter Programming	53
A. Introduction	53
B. Operational Parameters (Zero Menu)	53-54
C. Initial Operation Monitoring	54
1. Normal Running Indications	54
2. Drive Status Parameters	54-55

2 Table Of Contents

Section	Page #
Programming Flowcharts	56-67
Parameter Descriptions with Default Values	68-134
Start-Up Guidelines : General Wiring and Inspection	135
A. Test Equipment	126-137
B. Mounting Controller	137-138
C. Recommended Wiring Methods	138
1. Single Point Ground	138
2. Race Ways	138-139
3. Incoming Power	139
4. Field Connections	139
5. Motor Thermostat	140
6. Shielded Wire	140
7. Snubbers	140
D. Visual Inspection	140-141
E. Motor Inspection	142
F. Isolation Transformer Inspection	142
G. Ground Checks	143
H. Power Up and Voltage Checks	143-144
I. Motor Field Voltage Checks	144
J. Cooling Fans	144
K. Power Module Wiring	145
L. Motor Rotation	146
Specifications	147
A. General	147-150
B. Mentor Model Number Nomenclature	151
C. Dimensions	152-154
D. Power Module I/O Pin-Out	155-158
User Interface Board	158-159
A. Logic Description of Interface Board	159-161
B. Programming (Status) Relay Outputs	162-163
C. Status LEDs	163
D. Interface Board I/O Pin-Out	164-167
Spare Parts	168
A. Circuit Breakers and Line Fuses	168
B. Armature Contactors and Fuses	169
C. Burden Resistors	170-171
D. Dynamic Braking Resistors	172
E. Control Transformers and Fuses	173
F. Heating and Cooling Information	174
Troubleshooting	175
A. General	175-177
B. Drive	177-179
C. Fault Indication (Fault Codes)	180-184
Warranty Policy and Information	185

How To Use This Manual

This manual is designed to get users up and running as quickly and as easily as possible. Electricians, technicians, and engineers experienced in drives systems will find the start-up information to be presented from the front of the manual to the back in sequence of the set-up steps required. Information beyond ensuring motor speed regulation is offered in a series of sections beginning with Programming Flowcharts on page 56. The use of these flowcharts is critical for drive set-up and operation monitoring.

Precautions

Before going any further, please read and understand this manual completely. Always observe the following DANGERS and CAUTIONS when working on the equipment. And finally, if you are not sure about a certain step, read the section again. If you have any further questions, CONTACT YOUR SUPPLIER or DANAHER MOTION ENGINEERED SYSTEMS CENTER. Even a very reliable piece of equipment can easily be destroyed by incorrect installation or operating procedures.

DANGER

The National Electrical Code (Publication NFPA No. 70) requires that a fused main disconnect switch be installed between the incoming AC line and the drive system or, if used, the power transformer. (Specifically, this includes the Controller.) Serious personal injury or death may result if a disconnect switch is not provided.

When a M4000 unit is combined with user-chosen components to form a drive package, the user is responsible for proper selection of parts and subsequent operation. When a M4000 Controller is being used, it should be installed, adjusted and serviced only by qualified personnel who are familiar with the operation of all major components in the system. Serious personal injury or death, and/or equipment damage, may result if this procedure is not followed.

Only personnel familiar with electronic equipment should perform the start-up, calibration, and servicing of this equipment in this drive system, related machinery, and the potential hazards involved. Failure to observe this warning can result in serious personal injury or death, and/or equipment damage.

4 Quick Start

QUICK START M4000

Chassis, Enclosed or Power Module units.





The Quick start guide is provided to **allow basic hookup and operation of M4000 series DC drives**. The diagrams on the following pages show how to hook up an **M4000 Chassis, Enclosed and Power Module drive versions**.

DANGER

Serious personal injury or death and equipment damage may result if the Precautions on page 3 are not reviewed, prior to the installation of the drive.

The **Mentor drive has digitally programmable parameters** that affect the operation of the drive. **The Key parameters and their function are listed below**. A full description of all parameters is located Starting at page 68 of this manual.

The Mentor drive is shipped from the factory pre-programmed with parameters set based on the HP rating of the drive and current standard motor data regarding armature current, armature voltage, field voltage and field currents. It is common for parameters to be adjusted to fine tune the operation of the Mentor drive for your application.

To view and change all Mentor parameters go to Parameter (0100) by using the  or  and  or  keys. Press the Mode key, and the **data window will flash**. Use the up  key until the **data equals (0200). This is the security code**. Press the **mode key** again. The data window will stop flashing. The parameters can now be adjusted by selecting the parameter that you want to change and then pressing the Mode key to enter program mode (the data window will flash). Using the up or down arrow keys, change the data as required. Press the mode key again (the data window will stop flashing). **Once all the parameters have been modified they must be stored into permanent memory. If this is not done when the power is turned off you will lose your parameter changes. To store parameter changes into permanent memory, select Parameter (0100) and press the mode key to enter program mode and change the value in the data window to read (0001). Make sure the drive is stopped and press the mode key, then press the reset key.** The drive will reset itself and go through a normal power up routine. This will place your changes into permanent memory. To obtain further information about programming the drive refer to page 17.

PARAMETER #	FUNCTION	DESCRIPTION
0106	Max . speed	Sets the Maximum speed of the drive in the forward direction. Range of adjustment (0-1000), 1000=100%.
0107	Min. Speed	Sets the Minimum speed of the drive in the forward direction. Range of adjustment (0-1000),1000=100%.
0204	Forward. Accel Time	Sets the time it takes for the drive to accelerate forward to max speed. .Range of adjustment (0-1999),1999=199.9 seconds.
0205	Forward Decel Time	Sets the time it takes for the drive to decelerate forward from max speed. .Range of adjustment (0-1999),1999=199.9 seconds.
0207	Reverse Accel Time	Sets the time it takes for the drive to accelerate reverse to max speed .Range of adjustment (0-1999),1999=199.9 seconds. (Regen drives only.)
0206	Reverse Decel Time	Sets the time it takes for the drive to decelerate reverse from max speed. .Range of adjustment (0-1999),1999=199.9 seconds. (Regen drives only.)
0405,0406	Current limit Bridge1,2	Sets the current limit for bridge 1 and bridge 2 respectively. Range of adjustment (0-1000), 1000= 150%.
0312, 0313	Feedback Selection	These two parameters select the type of feedback the drive uses. Selections are: (0312=1 Encoder feedback used), 600ppr quadrature encoder minimum required. (0312=0 & 0313=0 tach. feedback used), recommended 50VDC/1000rpm tach. (0312=0 & 0313=1 Armature feedback used). If used refer to parameter 0315
0611	Field regulator Feedback scaling	This parameter is used only in drives 100Hp and below at 460VACinput and 50Hp and below at 230VAC input unless a FXM-5 external optional field controller is used. This parameter sets the maximum range of current the field in the motor uses.
0608	Max field 1	This parameter is used to adjust the current to a value lower than the max current range set in parameter 0611. This allows for fine tuning for the exact motor field current require
0609	Field Economy Max field 2	This parameter should be set to ½ the value set in parameter 0608.
0315	Max Arm Volt.	Sets the Armature voltage on the drive to match the Arm. voltage rating of the motor. Used for Armature Feedback and the Armature voltage clamp.

Chassis or Enclosed units connection Diagram.

If you have purchased a non-regen drive then the connection you should make for the start and stop circuit is as shown in figure 1

There are three types of stopping modes available with the Mentor regen drive. To use Ramp Stop or Decel stop use the main drawing connections. To have the drive coast/DB stop use (Fig. 1). To have the drive stop rapidly with full torque use (Fig. 2). To use all three stop modes use (Fig. 3). If any stop mode is not required, replace the push button with a wire jumper. If a contact or jumper is not used to connect each stop input, the drive will not start.

MENTOR Chassis or Enclosed connection diagram.

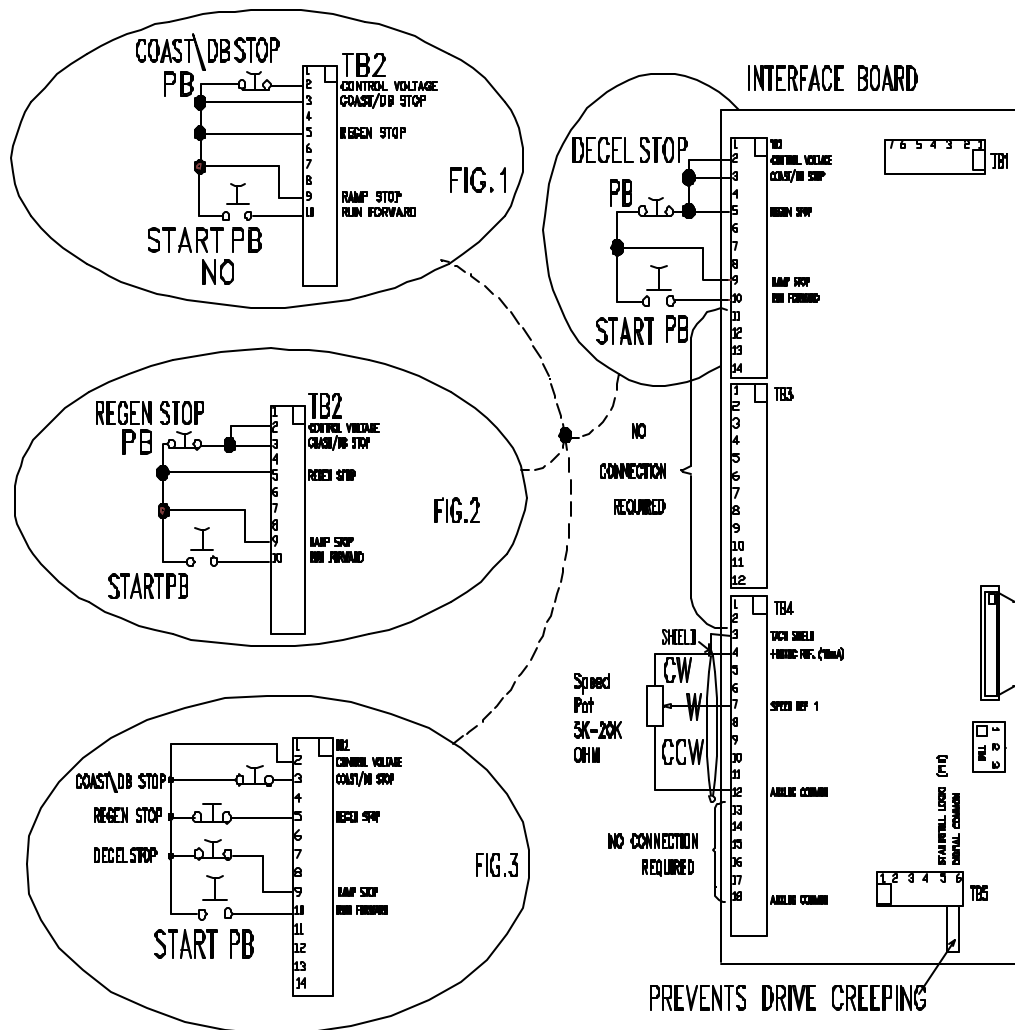

6 Quick Start

Power Module connection Diagram.

If you have purchased a non-regen drive then the connection you should make for the start and stop circuit is as shown in figure 1

There are three types of stopping modes available with the Mentor regen drive . To use Ramp Stop or Decel stop use the main drawing connections. To have the drive coast/DB stop use (Fig. 1). To have the drive stop rapidly with full torque use (Fig. 2). To use all three stop modes use (Fig. 3). If any stop mode is not required, replace the push button with a wire jumper. If a contact or jumper is not used to connect each stop input, the drive will not start.

MENTOR Power Module connection diagram.

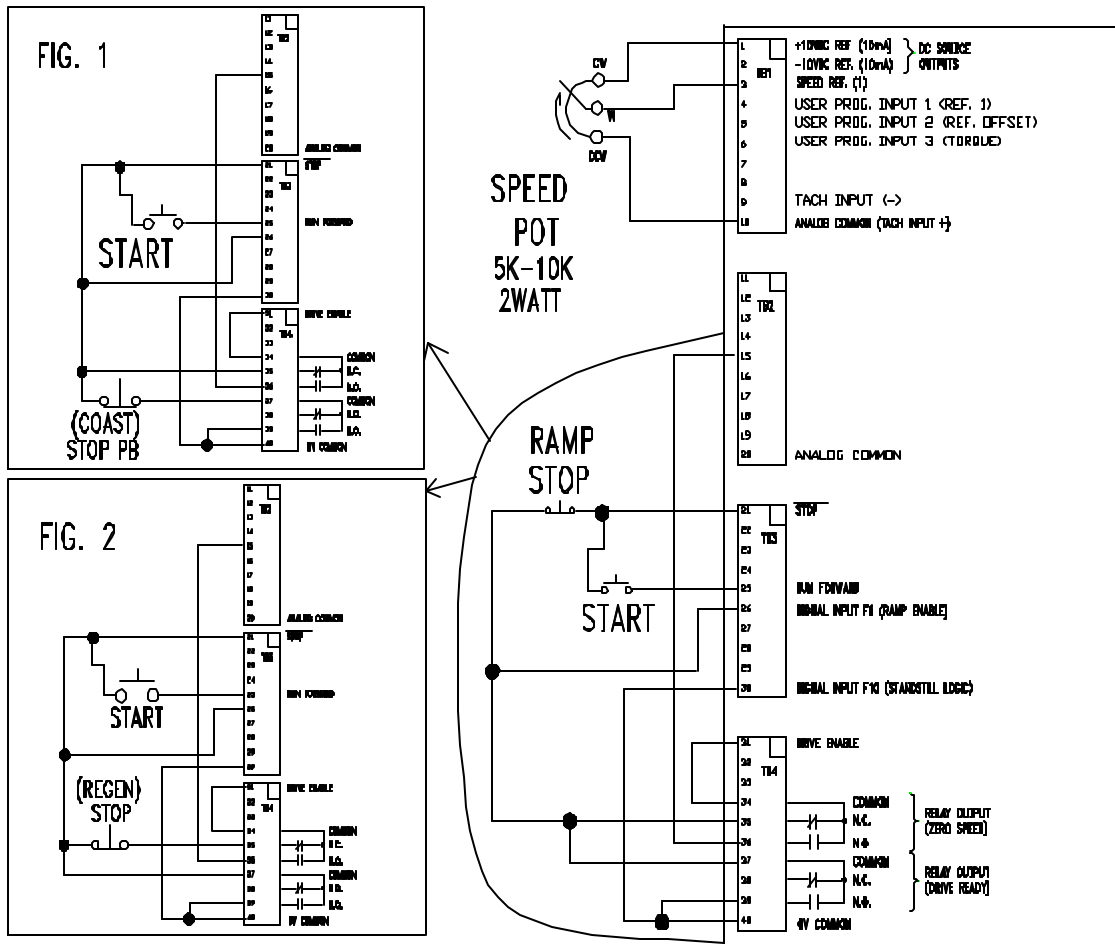

Features and Benefits : An Introduction to the Mentor II (M4000 Series) DC Drive

Thank you for choosing the M4000 (Mentor II) DC Drive. The M4000 DC Drive is a wise choice for compact, easy to use, and reliable motor control. The M4000 can be used from the simplest one motor applications to sophisticated multi-drive systems for complete process control.

To better fit your application, the M4000 DC Drive is offered in a variety of options and packages.

A. The Power Module

The M4000 **Power Module** or Power Unit is the heart of every M4000 series drive. It contains the control circuitry and power conversion components that convert incoming AC line voltage into adjustable, regulated DC voltage. The Power Module or Power Unit provides the ability to control a conventional DC motor.

The M4000 may be used in applications within the following ranges:

From 5 to 500 HP with a 230 VAC, three phase input voltage, either regenerative or non-regenerative.

From 5 to 1000 HP with a 460 VAC, three phase input voltage, either regenerative or non-regenerative.

The power module is designed to be integrated into a drive package selected and wired by the user. However, additional items may be required to transform the power module into a fully functional system. Examples include :

- ? Speed Potentiometer - 2K-10K ohm, 2 watt
- ? Run Pushbutton or relay contact
- ? Stop Pushbutton or relay contact
- ? Jog Pushbutton or relay contact (if desired)
- ? Forward/Reverse switch or relay contact (Regen units only)
- ? Line Fuses or Circuit Breaker (Required by code)

In addition, an Armature Contactor is HIGHLY RECOMMENDED, to provide positive motor disconnect when drive is stopped. Generally this is required by code.

The Power Module includes a front panel interface with an operator's keypad, LED Status Indicators, and parameter programming displays detailed in the Programming The Mentor II DC Drive section of this manual.

The following diagrams show the Mentor II Power Module physical in each HP range.

8 Features and Benefits

PHYSICAL COMPONENT LOCATOR

M4000 5-75HP / 460VAC Input

M4000 5-40HP / 460VAC Input

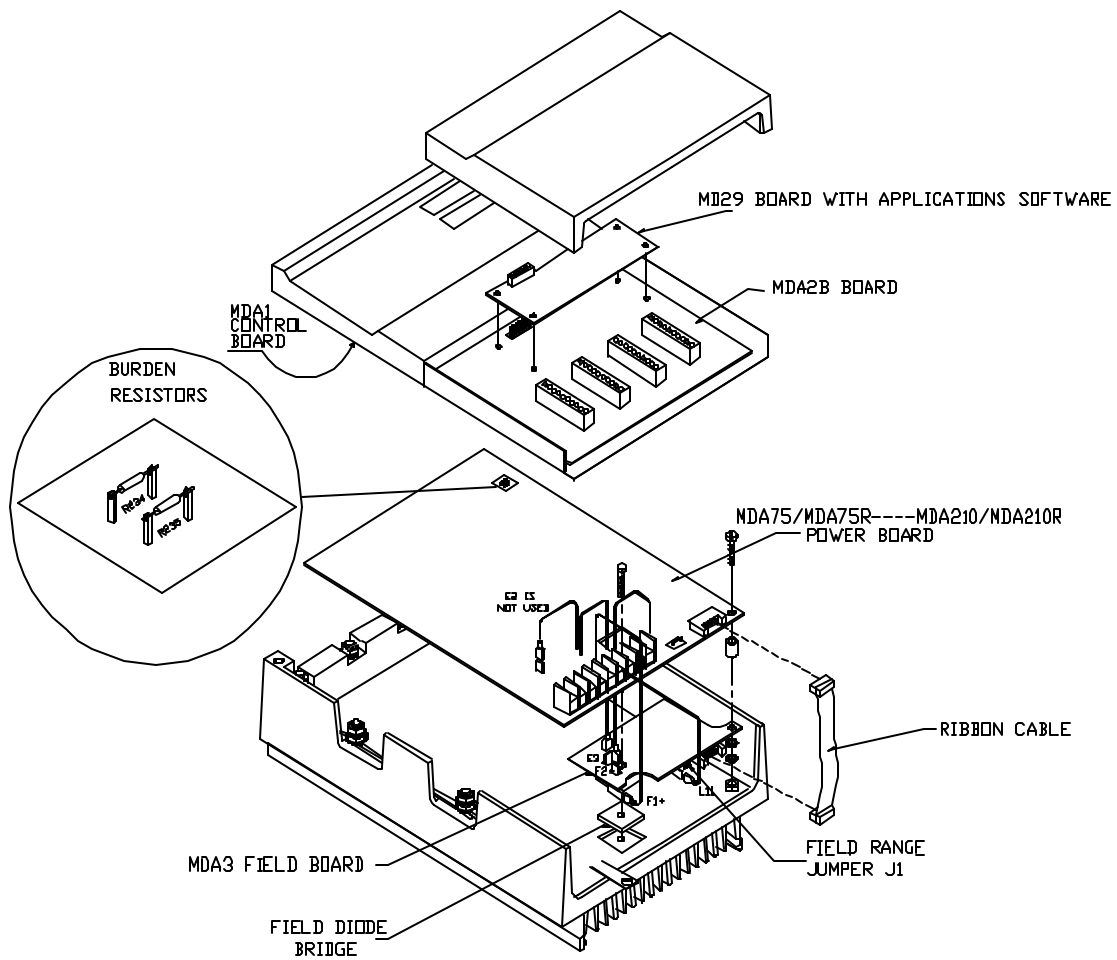

PHYSICAL COMPONENT LOCATOR
M4000 100-500HP / 460VAC INPUT
M4000 50-250HP / 230VAC INPUT

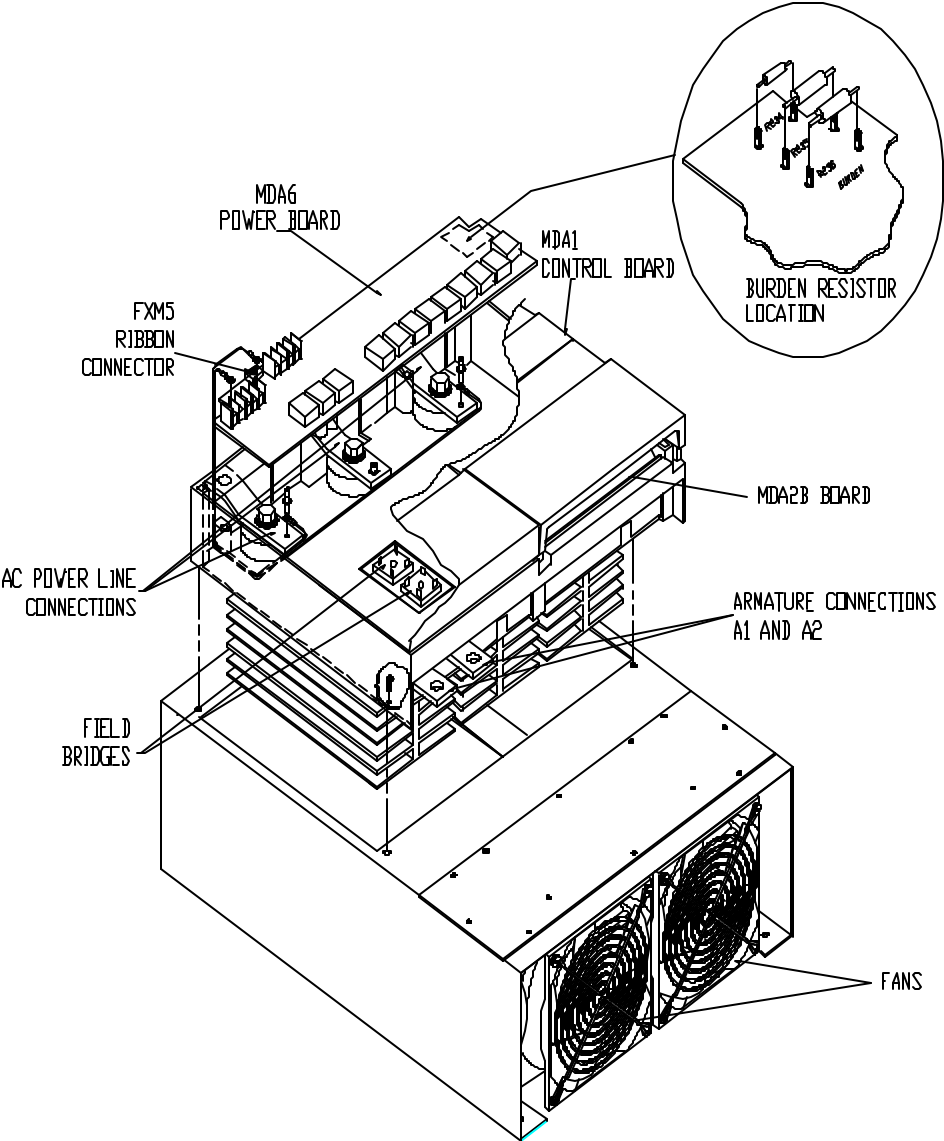

10 Features and Benefits

B. Packaged Drives

Unlike its counterpart (the Power Module), the Packaged Mentor II DC Drive is a complete motor control system. Packaged Drives include the following types of units:

RUN/STOP drives consist of the Mentor Drive Module, 115 VAC control transformer, armature contactor, AC line fuses, User Interface Board, and in some sizes, field economy module and cooling fans. This type of drive is Non-Regenerative, and is intended for unidirectional motor speed control.

RUN/BRAKE drives consist of the same components found in the RUN/STOP model, but include Dynamic Braking resistors. This unit is used for unidirectional motor speed control where occasional braking to stop is required.

REVERSE/REGEN-STOP drives are four-quadrant regenerative units consisting of the Mentor Drive Module (Regenerative), 115 VAC control transformer, armature contactor, AC line fuses, armature fuse, User Interface Board, and in some sizes, field economy module and cooling fans. This unit is used for bi-directional motor operation, where frequent stopping is required, or where quick response to speed changes is required.

REVERSE/REGEN-BRAKE drives consist of the same components found in the REVERSE/REGEN-STOP model, but include Dynamic Braking resistors. This unit is intended for similar applications to the REVERSE/REGEN-STOP unit, but where dynamic braking is required for conditional (E-Stop) stopping.

A motor field regulator (for field currents up to 8 amps) is included as a standard feature built into Power Units on drives rated up to 100HP at 460V and 50Hp at 230V. A field regulator for higher currents and/or higher horsepower units is supplied as an option.

Each of the above listed models is available as a chassis-mount or as an enclosed unit. Enclosed units through 20 HP at 460 volts or 10 HP at 230 volts are rated NEMA 12. Larger enclosed units meet NEMA 1 requirements.

Other power ratings and special features are available as engineered drives. This manual may be used to supplement the information provided as part of an engineered drive and/or system.

In addition to these drives, DANAHER MOTION ENGINEERED SYSTEMS CENTER also offers DC motors that can be matched to the needs of your application.

The packaged drive physical is shown on the following pages in its various HP ranges.

Chassis Component Location
5-60 HP @ 460 VAC
5-30 HP @ 230 VAC

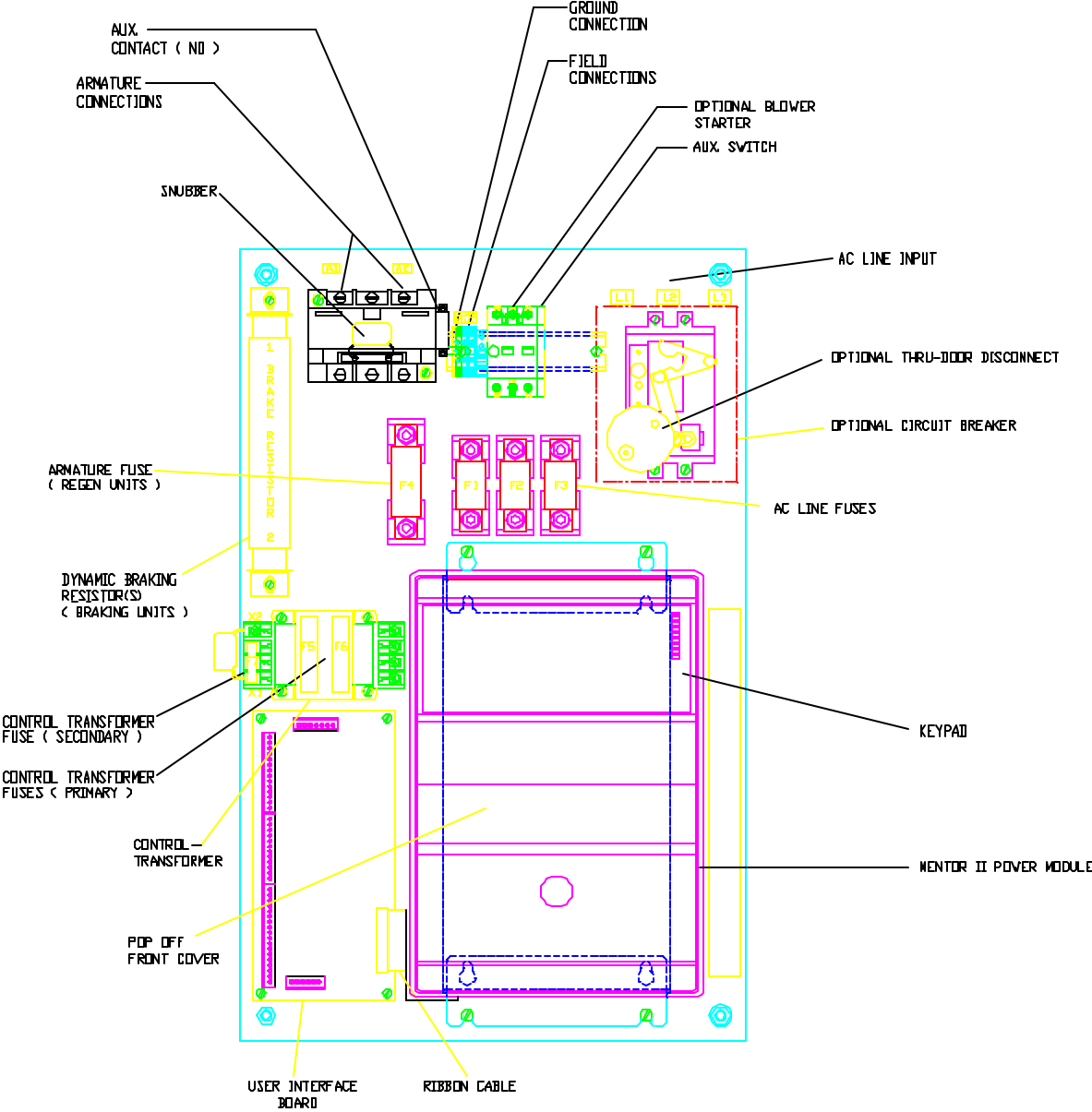

12 Features and Benefits

Chassis Component Location

75-100 HP @ 460 VAC

40-50 HP @ 230 VAC

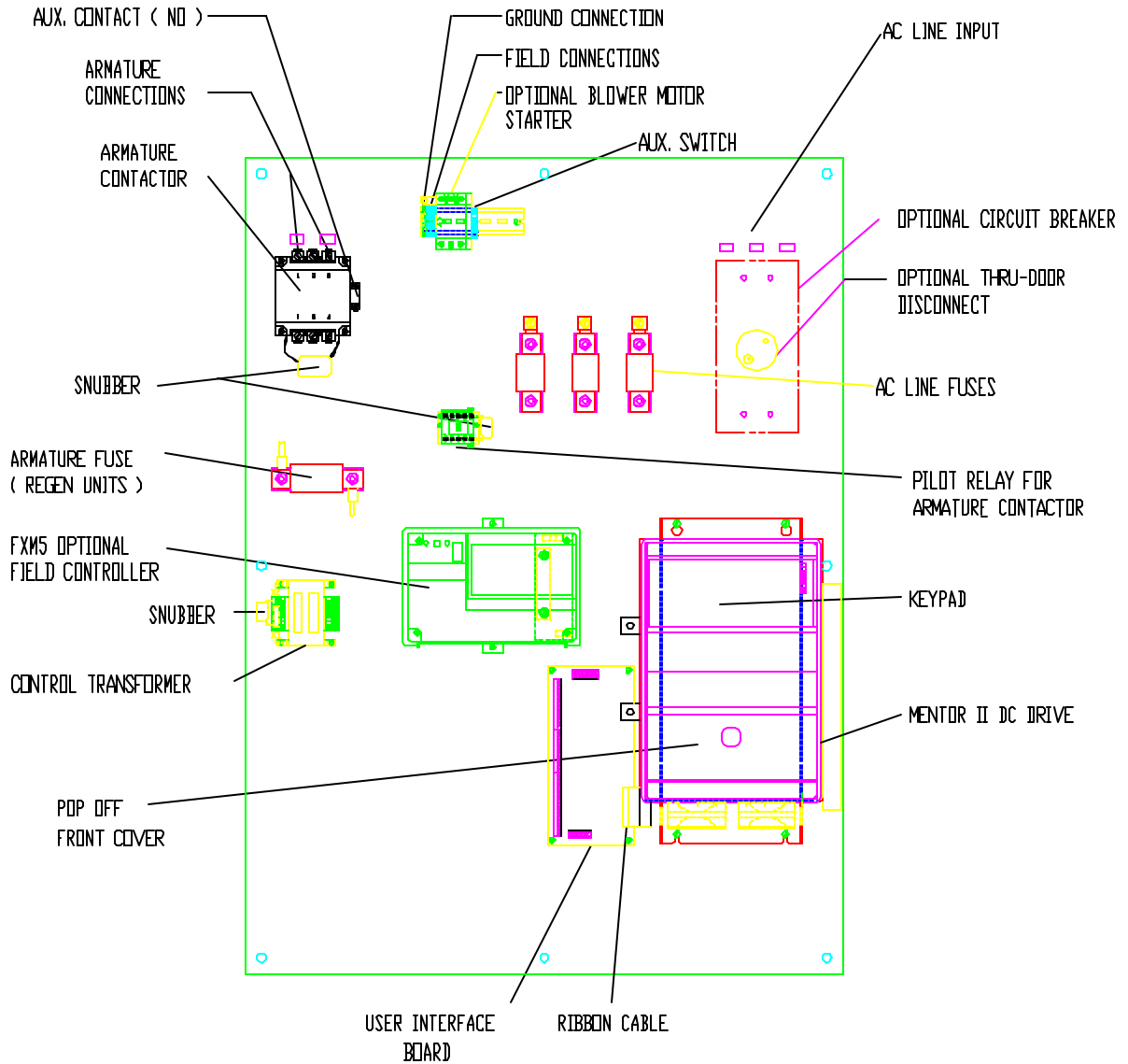

Chassis Component Location

125-200 HP @ 460 VAC

60-100 HP @ 230 VAC

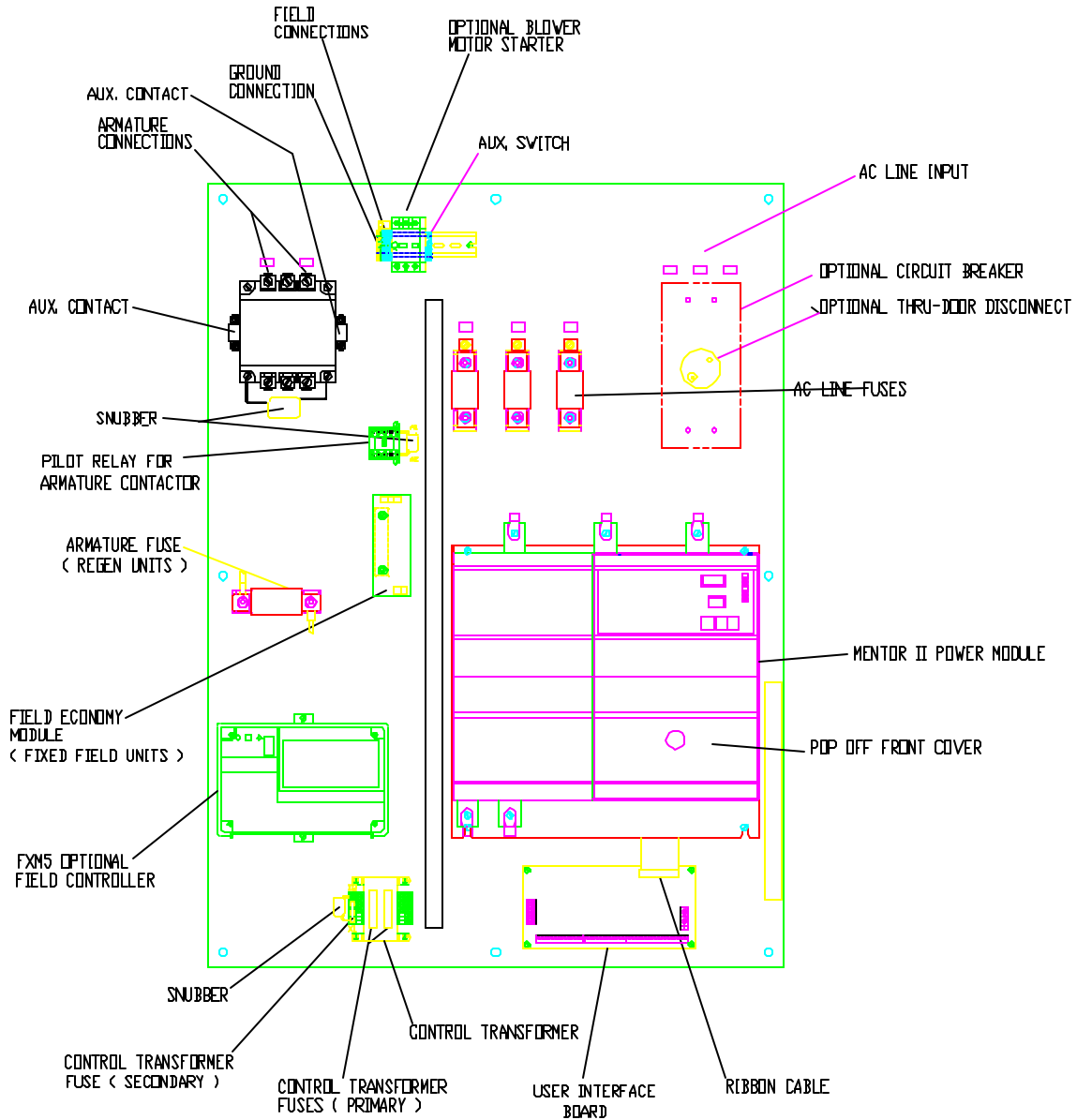

14 Features and Benefits

Chassis Component Location

250 HP @ 460 VAC

125 HP @ 230 VAC

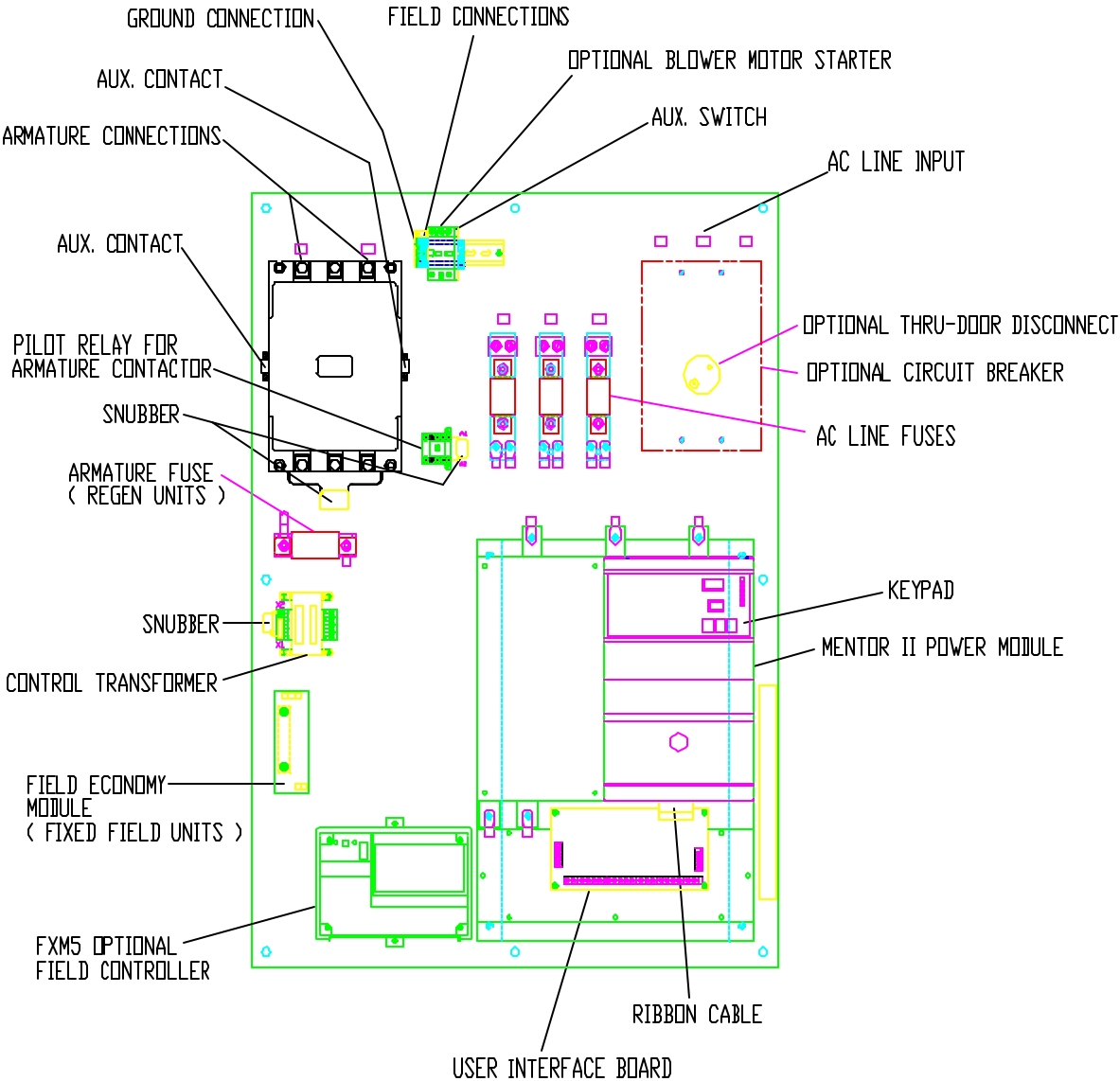

M4000 Interface Board Connections

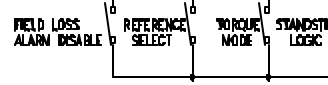
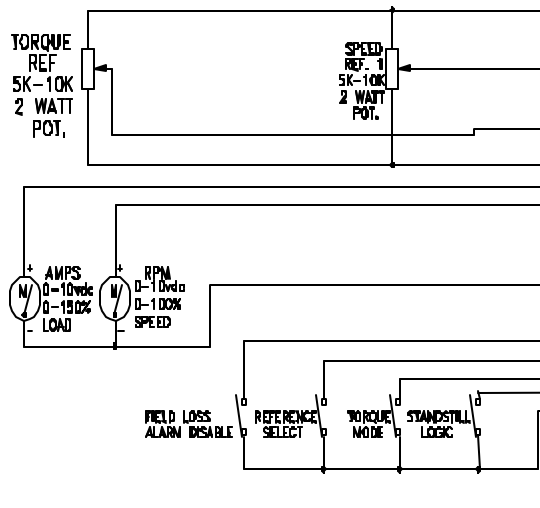
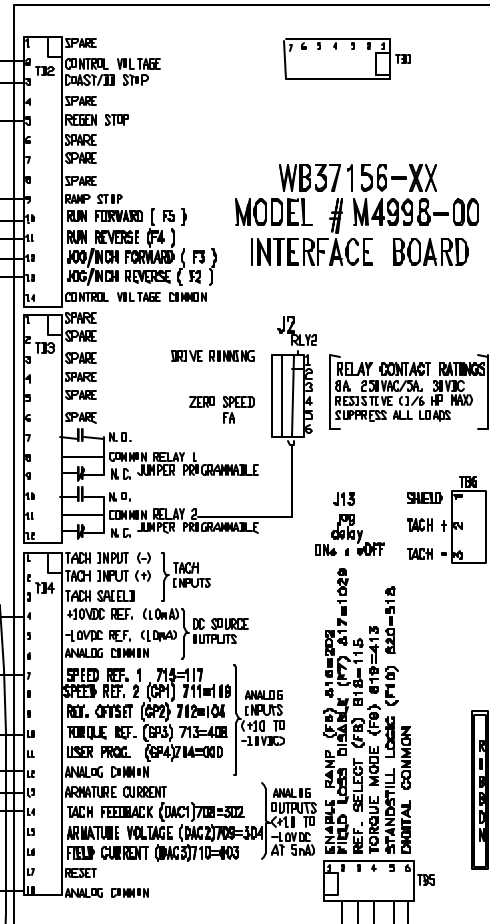
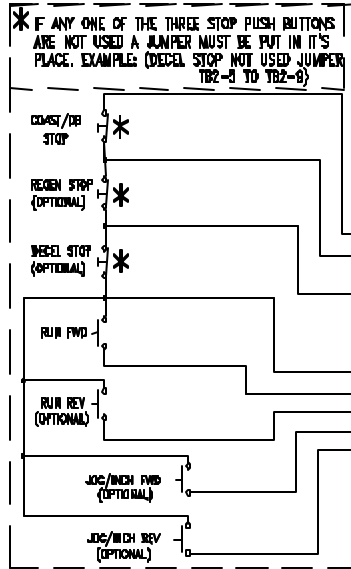
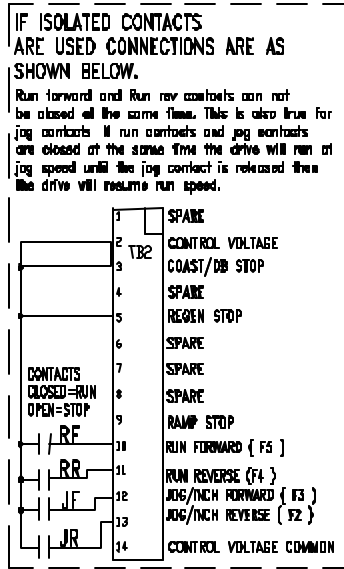

16 Wiring Diagrams

M4000 Power Module Connections

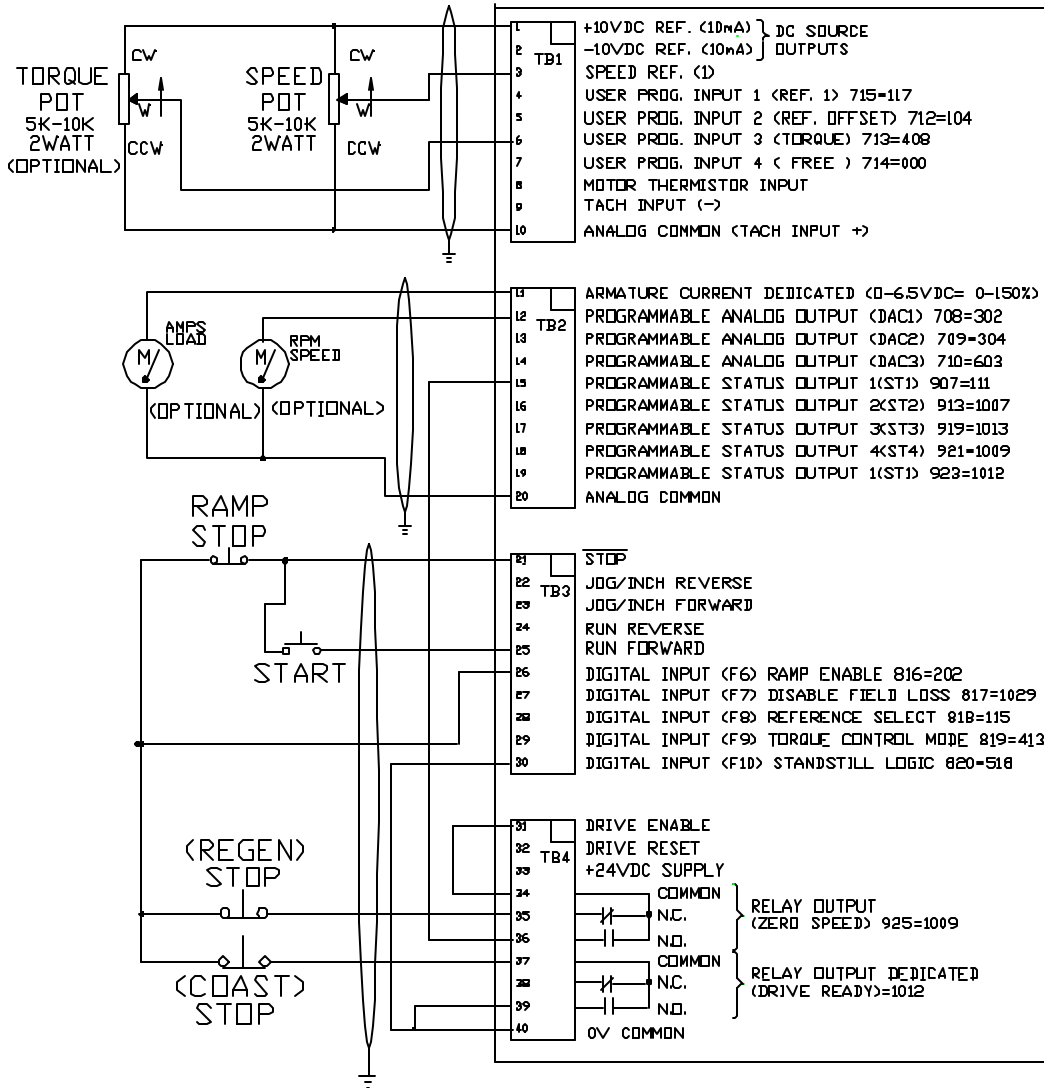

IF ONE OF THE STOP
 PUSHBUTTONS IS NOT
 USED THEN JUMPER
 IT OUT, EX:(RAMP
 STOP NOT USED
 JUMPER TB3-21 TO
 TB3-26.

PROGRAMMING THE MENTOR II DC DRIVE

A. Menu Structure

The M4000 is a very flexible unit by virtue of the many adjustable parameters available to the operator. The M4000 is menu driven with up to 17 groups (menus) of parameters (counting the zero menu), each based on a particular function (Analog I/O, Speed Feedback, Current Loop, etc.). Where many competitive units require multiple adjustment potentiometer, jumpers, and costly diagnostic options, the M4000 allows parameters to be displayed or changed through a simple keypad. Using the right or left arrow keys on the keypad, the user is able to scroll from menu to menu. Once a menu is selected (i.e. 3.00), the up or down arrow keys scroll from parameter to parameter in that selected menu (i.e. 3.01, 3.02, 3.03, etc). The scrolling function rolls over at each end of the table so if the user presses the right arrow key after selecting the 16.00 menu, the Parameter Index window will turn over to the 0.00 menu. The table below shows a portion of the menu structure.

	← Menu →				etc...
Parameters	1.00	2.00	3.00	4.00	5.00
↓ ↑	1.01	2.01	3.01	4.01	5.01
	1.02	2.02	3.02	4.02	5.02
	1.03	2.03	3.03	4.03	5.03
	1.04	2.04	3.04	4.04	5.04

B. Modes Of Operation

In order to make the most of the simple keypad provided, and to allow operation without danger of accidentally altering parameters, several MODES OF OPERATION are possible. The operator can choose to RUN, DISPLAY (view and monitor) a parameter, or Edit (change) a parameter. Thus, modes of operation include:

1. Power Up
2. Normal Running
3. Parameter Access (see section on security)
4. Edit (parameter adjustment)
5. Fault (tripped)

18 Programming The Mentor II

C. Description Of Keypad

The front panel (and keypad) of the M4000 Drive Module includes the following items:

1. Parameter Index Window Display
2. Parameter Data Window Display
3. LED Drive Status Display
4. "UP" Arrow Key
5. "DOWN" Arrow Key
6. "LEFT" Arrow Key
7. "RIGHT" Arrow Key
8. "MODE" Key
9. "RESET" Key
10. Programming Instructions

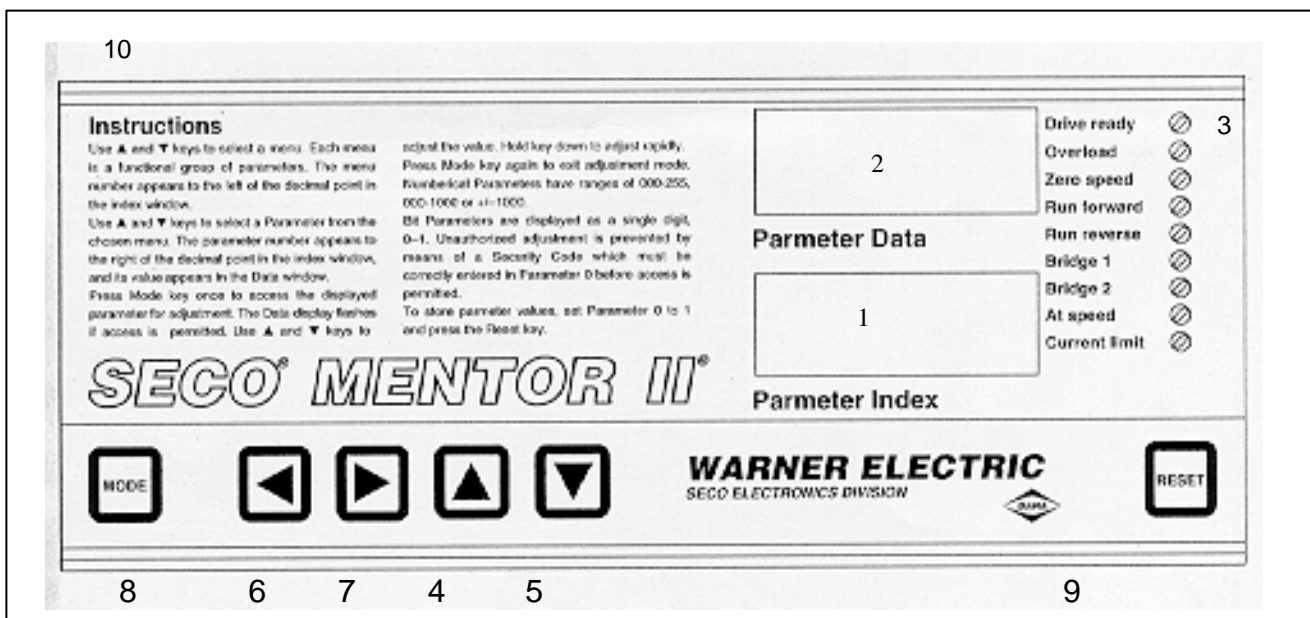

Mentor II Keypad

For first time users, don't forget the Status LEDs mentioned above. The Status LEDs are very useful when monitoring the drive during run-time. These LEDs indicate if the drive is ready, running forward or reverse, overloaded, etc.

D. Parameter Selection and Editing

Parameter values may be changed by selecting the required parameter by using the UP, DOWN key. Press the Mode key once to access the displayed parameter value for adjustment. The Parameter Data Window flashes to indicate that access is permitted. Use the UP, DOWN keys to change the value. Press MODE key again to exit from the adjustment mode. If the Parameter Data Window flashes but will not change during editing, the parameter is either 1) a read-only, R/O, shown as a diamond in the programming flowcharts beginning on page 56 2) a parameter that is controlled by an analog or digital input (see section H for details on destination and source parameters).

E. Store (Save) Procedure

Store (Save) parameter values after changes have been made, otherwise, the values will be lost when power is removed from the drive.

To store, select PARAMETER 0.00. Press the Mode Key (the Parameter Data Window will flash) and change the value to 001. Press the Mode Key again (the Parameter Data Window will stop flashing). Wait 3 seconds and press RESET. The drive will go through its power up or reboot routine if the drive is stopped. If the drive is running, “RES” will momentarily appear in the parameter data window.

Parameter 0.00 is also used to set a security code to gain access to parameters in order to change certain set-up features.

F. Security

After selecting a parameter number and pressing the MODE key, if the Parameter Data Window flashes, the user can change the value. However, if the Parameter Data Window does not flash, the parameter is :

1. RO, a Read-Only
2. R/W, a Read-Write but is protected by security. In this case, the security code must be entered before the parameter's value can be changed.
3. R/W, a Read-Write but is being pointed at by a programmable input (analog or digital). In this case, the destination parameter will have to be changed.

Security (As Set By Factory)

To access all parameters,

- ? Select any X.00 parameter (i.e. 0.00, 1.00, 2.00, etc.)
- ? Press the MODE key and the Parameter Data Window will flash (indicating entry to “edit “mode).
- ? Use the up or down arrow keys to write 200 in Parameter Data Window.
- ? Press the MODE key and the Parameter Data Window will stop flashing.
- ? All parameters can now be viewed or changed.

Disabling Security

To cancel security –

- ? Set any X.00 parameter to a value of 200, as described in the Security (As Set By Factory) section above.
- ? Select parameter 11.17 using the arrow keys.
- ? Press the MODE key and the Parameter Data Window will flash.
- ? Use the up or down arrow keys to write 000 in the Parameter Data Window.
- ? Press the MODE key and the Parameter Data Window will stop flashing.
- ? Perform the Store Procedure.

20 Programming The Mentor II

Note : If security is cancelled then there will always be free access to all parameters.

To reinstate security –

Repeat the procedure above but set parameter 11.17 = 149 and store.

User Defined Security Codes

An additional user-defined security code is also available. The code is user-programmable from 1 to 255 EXCEPT 149. If applied, access to all parameters will be denied until the user-defined security code has been entered prior to entering the generic security code of 200.

To assign an user-defined security code number -

- . Set the generic security code of 200 to any X.00 parameter.
- . Select Parameter 11.17 using the arrow keys.
- . Press MODE and the Parameter Data Window will flash.
- . Use the up or down arrow keys to write any 3-digit number from 1 to 255 to the Parameter Data Window (excluding 149).
- . Press MODE and the Parameter data Window will stop flashing.
- . Perform the Store Procedure.

All access including viewing-only is denied until the user-defined and generic security codes have been entered.

G. Defaulting The Drive

There are rare instances where the user may want to default the drive. When a default is performed, it is important to keep in mind that the drive will NOT revert back to the default settings found in the parameter list and definitions. DANAHER MOTION ENGINEERED SYSTEMS CENTER sets the drive for these settings before shipment. It is recommended to go through the list of parameters and verify each before proceeding to set the drive up for your application. Ideally, the user should have a copy of the parameters and their values when the drive was set-up for the application on start-up. The procedure for defaulting the drive is :

1. Go to any XX.00 parameter (i.e. 1.00, 2.00, etc.) and press the MODE key. The Parameter Data Window will start flashing.
2. Use the UP arrow key to increase the value to 255.
3. Press the MODE key and then Press the RESET key.
4. The drive will go through its boot-up routine (as if power has been reapplied).
5. The drive is defaulted. Go through the parameter list and verify your settings.

H. Destination and Source Parameters

The power of the Mentor II DC Drive rests in its programmable I/O capability. The drive is shipped with factory settings that direct the analog and digital inputs and outputs to various parameters for control. An example is General Purpose Input 1 which is set by the factory to control the Speed Reference 3.

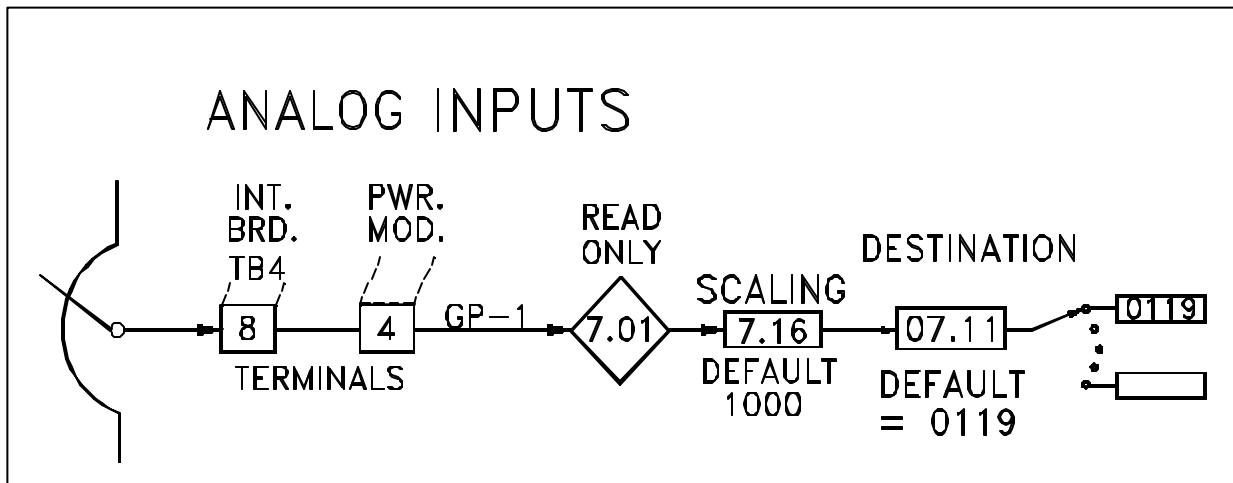

The example above shows a speed pot wired to General Purpose Input 1 of the power module. The raw analog input can be viewed in 7.01 (this is similar to using a digital voltmeter to check the input). Scaling is possible via 7.16 (the factory sets the scaling 100% or 1 to 1). Parameter 7.11 is shown as a **destination** parameter.

Defⁿ A **Destination** parameter controls where the information from the programmable analog inputs (GP1-4) is sent or in the case of Menu 8 (Logic Inputs) where the digital (logical) inputs (F7, F8, F9, and F10) are directed. Programmable Analog Inputs are typically used for inputs such as line speed signals, speed pots, ratio/trim pots, or tension pots. Digital (Logical) inputs are typically used to switch between preset speeds, change feedback or operation mode (i.e. from Armature Voltage Feedback to Tach Feedback or from Speed Mode to Torque Mode), or to enable/disable the accel/decel ramps, the standstill logic, field loss detection, etc.

By changing the destination parameter from a value of 119 to another read/write parameter value (i.e. 1.05 Jog Speed), the Mentor II provides the customer with the flexibility to reconfigure each analog input to meet the application demands (i.e Jog Speed Pot).

An example of a digital input being controlled by destination parameter is shown below. When F6 is tied to common (TB2-20 or TB4-40), the ramp (2.02) =1 and is enabled and when connection is severed (2.02=0) the ramp is disabled. When the destination parameter is changed to another read/write bit parameter, F6 is configured for a new control.

22 Programming The Mentor II

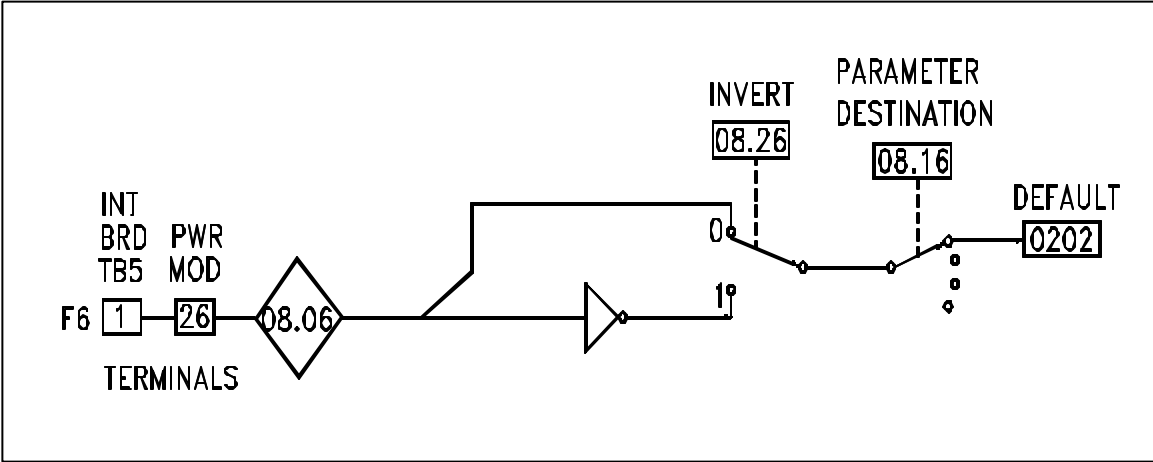

In the case of an analog output a source parameter is used to set the personality of the output.

Defⁿ A **Source** parameter controls the programmable analog outputs (DAC 1,2, and 3) or the Status Menu 9 which through selected logic controls the open-collector status outputs (ST 1-6). The source parameter is set to a value that equals the parameter number where the information to be outputted or where the information for decision-making is stored. The programmable analog outputs are typically used to send a +/-0-10 VDC signal to a PLC, another drive, or an analog or digital meter for line speed or current indication, etc.

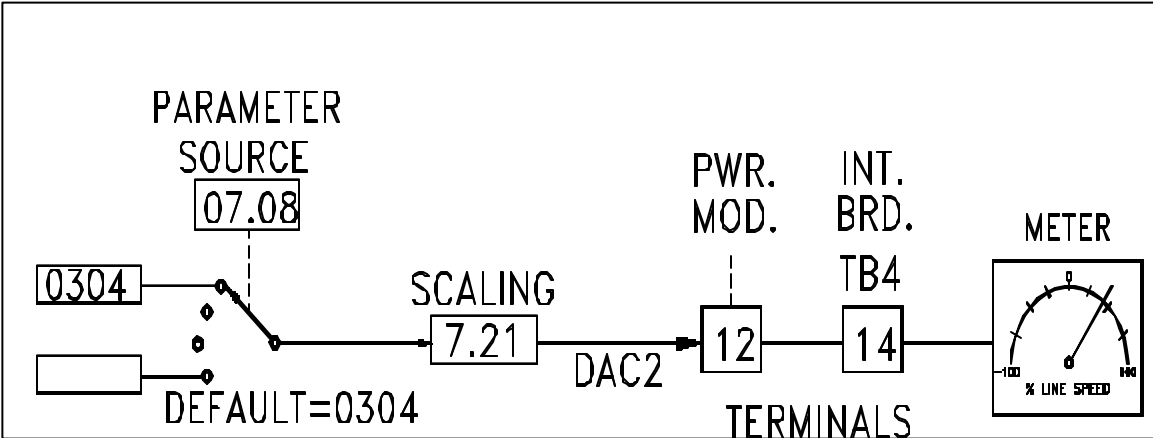

In the example above, the DAC 1 output (TB2-12) is set by the factory to look at the drive's speed feedback to output 0-10 VDC to an analog meter for an operator % line speed read-out. The DAC1 output is controlled by the source parameter 7.08 and the value in 7.08 is 302 (the drive's feedback parameter). It is possible for the user to redirect the analog output to another read/write parameter (i.e. 7.08=501 outputs 0 to 10 VDC based on 0 to 1000=0 to 150% Armature Current).

Digital Outputs are also controlled by source parameters as shown below.

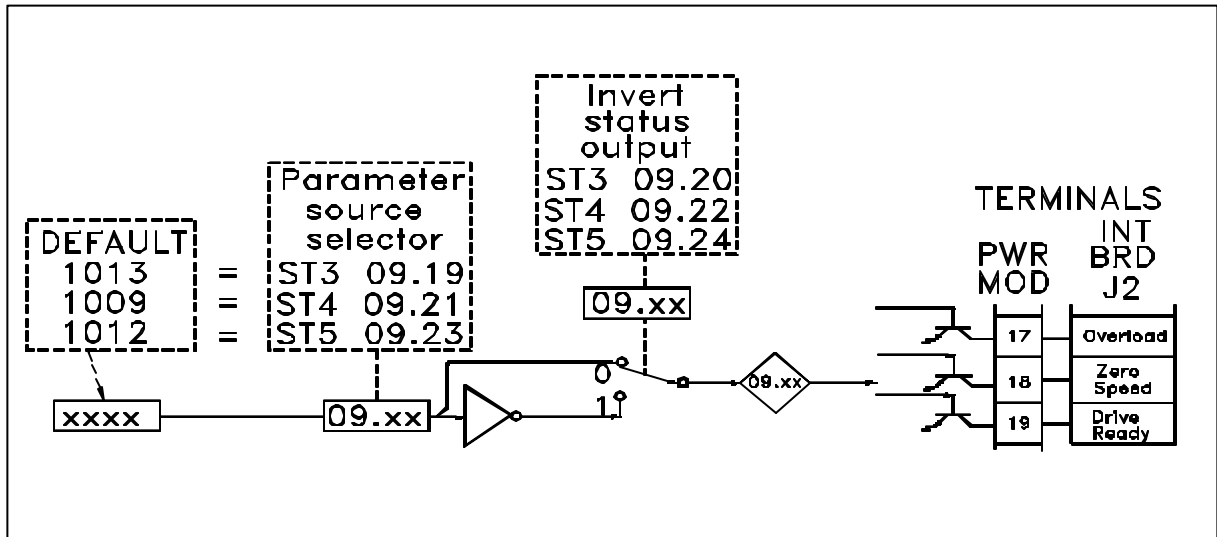

The example above shows an example where the source parameter 9.19 is set to a value of 10.13. Parameter 10.13 is a bit parameter whose value equals 1 if the drive is in the Overload State and a 0 when the drive is not. If the drive goes into an overload, the state of ST3 changes from off to on.

If a destination or source parameter is re-directed, the store procedure MUST be executed before the changes take effect

24 Programming The Mentor II / Special Motor Considerations

I. Threshold (Level Detection Menu 12) Parameters

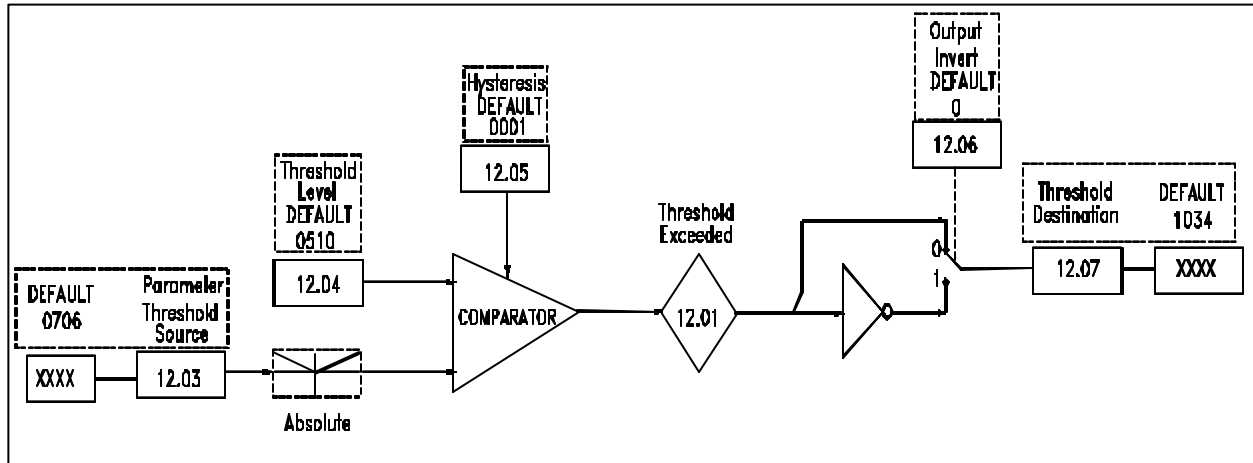

The example above shows the threshold source coming from the speed feedback parameter 3.02. A level is set in 12.04 (2 % of max speed in the example) , hysteresis is added in 12.05, and the Threshold Exceeded is Inverted and sent to 3.13 (Armature Voltage Feedback Select). Hysteresis is analogous to keeping a relay from chattering on and off. A good example of this application is a winder with a lay-on roll tach. When the winder is first started, no material has built up on the core and therefore the lay-on roll tach will not spin. If the winder drive were started in tach feedback then the drive would trip on a tach feedback loss. In this way, the drive starts in armature voltage feedback and when the speed feedback exceeds 2 % of max. speed, the threshold detection automatically switches the drive to tach feedback.

Special Motor Considerations

The Mentor II Drive nameplate is 240 VDC Armature and 150 VDC Field for a 230 VAC 3 phase AC input and 500 VDC Armature and 300 VDC Field for a 460 VAC 3 phase input. The MDA3 Field Current Regulator is set at the factory based on a typical motor's nameplate data. This means that the drive's settings will get you in the ballpark but they may have to be adjusted to obtain the motor's nameplate speed and full torque capabilities with your specific motor. Some motors fall out of range of the drive's nameplate (i.e. 240 VDC Armature and 240 VDC Field). Old MG set motors and European motors are notorious for uncommon motor nameplates. Note ! Be careful when using the Mentor II Drive with a motor that was previously used on a MG set. The motor inductance may be too low and drive tripping and erratic behavior may result. In this case an output choke may have to be installed in the armature circuit. Call your Local Danaher Motion Sales Representative or the Danaher Motion Engineered Systems Center when retrofitting a MG set with a DC drive.

Special Motor Considerations 25

Armature :

The armature voltage output of the Mentor II DC drive is based on the 3 phase AC input level (3 phase full wave rectified to pulsed DC) and parameter 3.15 (Maximum Armature Voltage). The Armature Voltage Clamp will become Active (see parameter 10.10 in the Status Menu) at 1.2 X (3.15) and the voltage will be prevented from increasing beyond that point.

230 -3 phase AC input is capable of outputting 310 VDC with the SCRs fully phased on.
240- 3 phase AC input is capable of outputting 621 VDC with the SCRs fully phased on.

This is the worse case scenario (DO NOT Operate where the SCRs are fully phased on as the SCRs may latch).

However, as a general rule of thumb, the motor armature voltage should never be 50 % or less than the drive's capable output. For example, a 240 VDC armature (motor nameplate) should never be installed using a 460 3 phase input drive. The drive is capable of outputting more than twice the motor's requirements. The primary reason to avoid this is that even though a 460 VAC drive can be limited to 240 VDC output (via 3.15), the SCRs are firing at twice the AC line. The result is pulsed DC with 2 times the peak amplitude which could in turn breakdown the motor's insulation and eventually damage the motor windings.

Field :

The Mentor II DC Drive's field output can be based on 4 different scenarios :

1. MDA3 Internal Regulator
2. MDA3 with 240 VDC Modification
3. FXM5 External Regulator
4. Fixed Field with Field Economy Board.

The MDA3 Internal Regulator is standard up to 50 HP at 230 VAC and 100 HP at 460 VAC. Field Weakening or extended speed range control is standard with the MDA3. Above these ranges the standard drive comes with a fixed field and field economy board. For field weakening or extended speed range applications at the higher ranges, an FXM5 External Regulator will have to be added as an option.

The MDA3 (Standard) produces a single phase full wave controlled pulsed DC output.
At 230 VAC 3 phase input the MDA3 is capable of outputting 207 VDC at a maximum of 8 amps.
At 460 VAC 3 phase input the MDA3 is capable of outputting 414 VDC at a maximum of 8 amps.

In the case where a 240 VDC field is required, a factory modification can be made as an option which adds an additional half wave uncontrolled rectification to the field output (103.5 VDC). This applies to the 230 VAC input ONLY. Because the 103.5 VDC is uncontrolled, there is a 2:1 voltage range on the 240 VDC field mod.

26 Special Motor Considerations

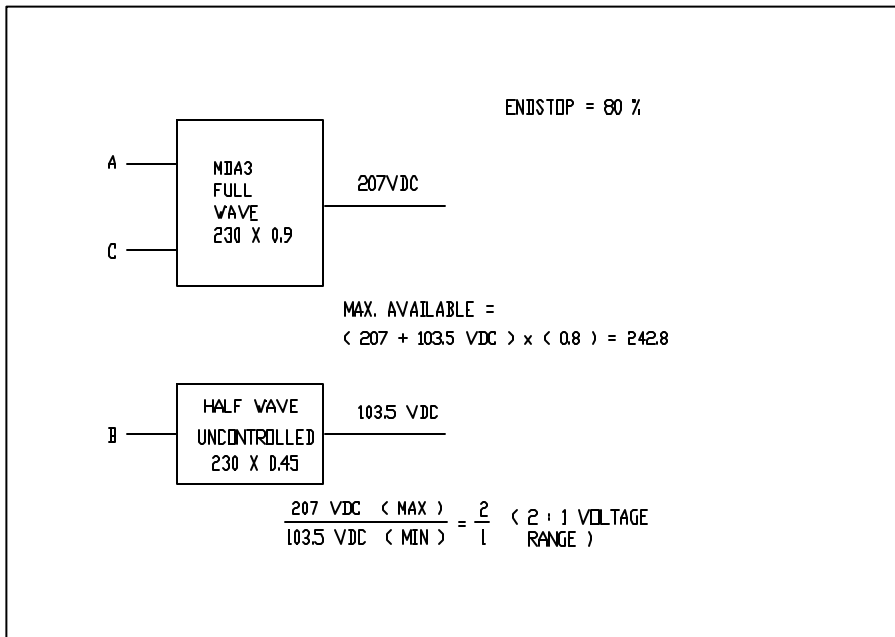

The amount of field weakening or overspeed will be motor dependent. For example :

Nameplate : 1750 / 2100 RPM. 3.04 / 1.05 Field Amps. (240 VDC / 3.04 ADC) = 78.947 Ohms

At min voltage, (103.5 VDC / 78.947 Ohms) = approximately 1.311 Amps.

Keep in mind that the field is a coil and exhibits inductive properties but the Ohms measurement is usually close enough to be used as an approximation.

The field will not be able to weaken any further than 1.311 Amps (even if the MDA3 is turned off). In this case, top motor speed is unobtainable (2054 is max. +/- 7%)

In the case where the armature voltage falls in one range and the field voltage falls in the other (i.e. 500 VDC armature and 120 VDC field), the factory can install a step-down transformer on the chassis back panel and make the necessary wiring modifications to accommodate the field controller.

Motor Field Supply Information and Set-Up Procedure

A. Motor Shunt Field

Standard M4000 drives have field supply voltages as follows:

- 230 VAC drives have 150 VDC field supply (nominal).
- 460 VAC drives have 300 VDC field supply (nominal).

Many motors are furnished with dual voltage fields (i.e. 150/300 VDC), and have two field coils, both of which must be connected. In this case, there are normally four field leads labeled F1, F2, F3 (or F11), and F4 (or F22). Typically, for a 150 VDC field F1 and F3 are tied together and F2 and F4 are tied together. In this format, the field coils are in parallel with each other. F1 and F2 are connected to the drive as the equivalent field. For a 300 VDC field F2 and F3 are tied together with F1 and F4 connected to the drive. In this format, the field coils are in series with each other. In motors where only one field coil is supplied, there are only two wires (F1 and F2). It is always recommended that the motor nameplate and drive ratings are verified before making any connections to insure the correct field voltage supplied by the drive corresponds to the motor's requirements.

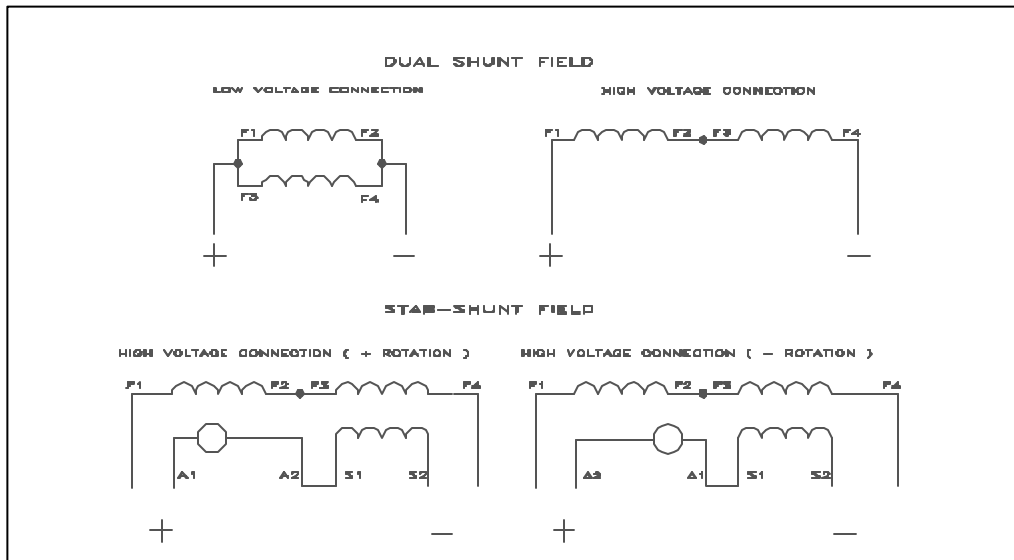

B. Motor Series Field

Normally, these connections should be made in accordance with the motor nameplate. If a **REGENERATIVE (reversing)** model M4000 is used, connecting the series field is **NOT** permitted. If a series field is present (generally marked S1 and S2), do not connect these leads. It is important to carefully insulate these leads from each other and from any other connection. Failure to do so will result in unstable operation, high armature currents, and erratic speeds. Note : In regenerative applications using very large HP drives it may be necessary to utilize the stabilizing benefits of the series field. This application requires the use of a steering bridge and should first be qualified by your regional Danaher Motion Representative.

28 Field Setup- Motor Field Supply Information/ MDA3 Internal Controller

C. Motor Field Supply

Older models of the Mentor II Power Module had a fixed field (no field regulator). Currently models above 100 HP have a fixed field. In these cases , field voltage is purely a consequence of the AC line. However, any Mentor II drive (M4XXX-00020A) which includes the Power Module, Chassis Mount, and Enclosed Packaged drives are standard with the MDA-3 Field Regulator (5-50 HP at 230 V and 5-100 HP at 460 V).

Note : Drives rated above 100 HP @ 460 VAC or above 50 HP @ 230 VAC require the FXM5 external field controller if Field Control is required (field weakening, etc.).

The Mentor II Drive nameplate field voltage (150/300 VDC) is based on setting the MDA-3 Internal Field Regulator for a current range based on a typical motor in the respective HP range. Since a motor's characteristics (field winding ohms, field current, etc) vary from motor to motor, it may be required to adjust the field setup parameters to achieve motor nameplate ratings. Though often misunderstood, it is actually the current that creates the magnetic field of the motor. Therefore, it is the field current that is critical and not the field voltage. (Note : it is still very important to verify field voltage to prevent overvoltageing the field.)

D. MDA-3 Field Regulator Set-Up

To set the MDA-3 to provide a constant current to the motor field, use the following procedure.

- 1) Remove AC power to the drive and/or drive cabinet and disconnect the motor field.
- 2) Determine the required current for correct field excitation from a motor data sheet or from the motor nameplate. Always make sure the field current amps rating corresponds to the correct field voltage rating. Remember ! Some motors have dual wound fields and the nameplate may have two values for field current and field voltage). Often the motors with dual field windings are nameplated at 300 VDC. For these motors where a 150 VDC field voltage is required, double the nameplate current values.

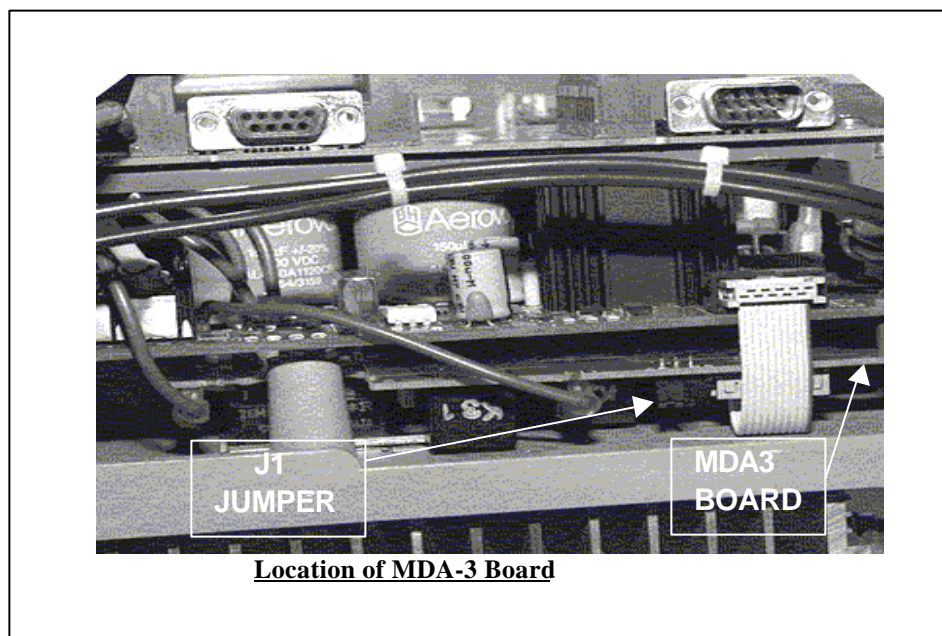

Field Setup- MDA3 Internal Controller 29

- 3) Set Jumper J1 on the MDA3 to the correct position. The MDA-3 board is located by first looking in the bottom right-hand corner of the Mentor II power module. Removing the pop-off cover of the drive makes viewing easier. The front board with four vertical terminals is labeled as the MDA-2 or MDA-2B board. Beneath the MDA-2 or MDA-2B board is the power board. The MDA-3 is piggyback beneath the power board in the bottom right-hand corner of the power module. A red wire from the field circuit loops around and terminates on the back of the MDA-3 board. A gray cable labeled PL6 on the power board also loops around and terminates on the back of the MDA-3 board. Between the red wire and the gray cable, on the front of the MDA-3 board, are the labels "2A 8A". The J1 jumper is located here on the back of the MDA-3 board. For currents up to 2 amps put J1 in the 2A position (left). For currents between 2 amps and 8 amps put J1 in the 8A position (right).

- 4) Reconnect the field. Power up drive select parameter 6.11 and set to one of the following values. Normally it is required to set 6.11 to the next higher range than the field current required. The reason for this is 6.21 (the field firing end-stop) is set to 800 (80 %) to prevent field overvoltage if the plant source becomes unloaded and the AC line goes high. To match the motor nameplate field current rating it is sometimes necessary to set 6.11 to two ranges higher. This is usually where the existing AC line is low.

Max Current	J1 Position	Parameter 6.11 Set point	Max Current	J1 Position	Parameter 6.11 Set point
0.5	2A	201	4.5	8A	209
1.0	2A	202	5.0	8A	210
1.5	2A	203	5.5	8A	211
2.0	2A	204	6.0	8A	212
2.5	8A	205	6.5	8A	213
3.0	8A	206	7.0	8A	214
3.5	8A	207	7.5	8A	215
4.0	8A	208	8.0	8A	216

- 5) Parameter 6.11 sets the maximum current available from the MDA-3 field regulator. In most cases, the motor nameplate field current amps will fall in between two ranges in the chart above. To facilitate field current adjustment, Parameter 6.08 provides a scaling of 0-1000 or 0-100% where 100% equals the max current available as set by Parameter 6.11. Example 1: 3.2 A is required and 6.11 is set for 208 (4 A max current available).

The value 3.2 A is 80% of the current available (4A). Therefore, Parameter 6.08 should be set to 800 (1000 = 100%). Calculate the value for Parameter 6.08 as a ratio of actual current to Max. Current (the value set in Step 4).

Parameter 6.08 is the ratio of (3.2/4.0) * 1000 = 800

Example2: If actual current required is 4.3 A, in Step 4, Parameter 6.11 would have been set for 211 for Maximum current of 5.5A.

Parameter 6.08 is the ratio of (4.3/5.5) * 1000 = 782

30 Field Setup- MDA3 Internal Controller

- 6) Power down drive.
- 7) Connect motor field and power up drive to check operation of the Field Controller. At this point it may be necessary to adjust Parameter 6.08 further to achieve exact motor nameplate ratings. Note: The resistance of the field coil(s) increases as the temperature of the windings rises. Typically the hot to cold resistance is an increase of approximately 40%. As the field coils get hotter, the resistance increases and the voltage will increase. It is usually a good idea to allow the motor to reach normal temperature before taking a final field current and field voltage reading.

E. Field Economy

On packaged drives not using a Field Control option (>100 HP @ 460, >50 HP @ 230) a Field Economy board is used. This circuit reduces the field voltage to 1/3 of nominal value 30 seconds after the Armature Contactor is disabled. When the drive is started the field voltage goes to the nominal value. This feature reduces the temperature of the motor field winding when the motor is not running and can prolong the life of the motor field insulation.

On Drives using a Field Controller, the Field Economy is controlled by the drive software. Where the MDA-3 applies, the Field Economy is controlled by Parameters 8.11 (Drive Enable), 6.09 (Reduced Field Scaling), 6.12 (Field Economy Timeout), 6.14 (Max. Field Current Select), and 6.15 (Field Economy Timeout Enable). To view a graphical representation of how these parameters work together, refer to the Programming Flowcharts (Menu 6, Field Control). The MDA-3 controls Field Economy by switching from Parameter 6.08 (Full Field Scaling) to Parameter 6.09 (Reduced Field Scaling) via Parameter 6.14 (Max. Field Current Select). If Parameter 6.14 = 0 then the final field current demand is derived by Parameter 6.08. If Parameter 6.14 = 1 then the final field current demand is derived by Parameter 6.09. The transition from Full Field Current to Reduced and vice-versa is based on the starting and stopping of the drive. Parameter 6.15 (Field Economy Timeout Enable) monitors parameter 8.11 (Drive Enable). When the drive is running 8.11 = 1 and when the drive is stopped 8.11 = 0. By monitoring the state of 8.11, the Field Economy Timeout Enable (Parameter 6.15) is enabled or disabled based on whether the drive is stopped or running. Suppose the drive is in the running state (8.11 = 1, 6.15 = 0, 6.14 = 0, Final Field Current Demand (6.02) = 6.08) and the stop command is given. Parameter 8.11 makes a transition from 1 to 0 which toggles Parameter 6.15 from 0 to 1. After x seconds time delay (set by Parameter 6.12), Parameter 6.14 makes a transition from a 0 to 1 and the final field current demand is based on Parameter 6.09 (Reduced Field Scaling). The default is set for 500 (0-1000 = 0-100%) which yields a 50 % reduction in field current while the drive is stopped for certain periods of time. Parameter 6.09 can be adjusted as required.

F. FXM5

Skip this section when a fixed field or MDA-3 Current Regulator is used for field control.

INTRODUCTION

The controller FXM5 is designed to control the field of DC motors up to 20 amps maximum. The FXM5 is a single-phase, half or full controlled-SCR rectifier bridge with a control logic PCB. The controlled rectifier can be configured by a selector jumper link to operate as a half-controlled or a full-controlled system.

The FXM5 can be used as a stand-alone unit where set-up is done via adjustable potentiometers on the PCB itself. However, this section assumes the FXM5 is connected via ribbon cable to the Mentor II DC Drive. When used with the MENTOR II, the FXM5 is controlled by the drive providing ease of field setup and control. In this case most adjustments will be made in the drive's programming and the potentiometers on the FXM5 have no function and are not used.

SCR-CONTROLLED RECTIFIER

The converter consists of two SCR modules, each consisting of a pair of series-connected SCR's. The SCR modules are interconnected to form a single phase symmetrical bridge. The power circuit contains RC snubbers and transient-voltage suppressors.

Half-wave and Full-Wave Control

In half-wave control mode, the current is allowed to free wheel when reduced. In full-wave control the current is allowed to return to the mains.

Important Note!

It is recommended that the field controller be used in the half-controlled mode rather than full-controlled, unless the application is one that demands that the field be capable of very rapid weakening (suppression), or if the time-constant of the motor is unusually long. In general, less current ripple is produced by a half-controlled output, and therefore torque ripple is less.

Control System

When using the FXM5 with a Mentor II DC Drive, the control system consists of the following parts -

- Ribbon Cable
- Field current amplifier
- SCR firing circuit.

Monitoring

A field current monitor visible from the front of the module indicates by LEDs the field current as a ratio of the maximum field current setting (0.1 to 1.0, in steps of 0.2).

32 Field Setup- FXM5 External Controller

SPECIFICATION

Supply Voltage

Any 50/60Hz AC voltage within 230 VAC - 15% to 460 + 10%

Field Voltage

200V min. to 430V max., depending on supply voltage.

Field Current

UP to 20A, depending on configuration of output, half, or full-controlled. The field current is scaled based on a ratio of the maximum field current setting (0.1 to 1.0, in steps of 0.2).

Control Voltage

Single phase AC 50HZ - 380V/440V \pm 10%, and 220V/254V \pm 10%, 60Hz - 460V/480V \pm 10%

Armature Voltage Feedback

220V to 600V DC. Must be protected by external fuses, max. rating 2A.

Operating Temperature Range

0 °C to 50 °C

Storage Temperature Range

-40 °C to +70 °C

Humidity

85% maximum, non-condensing.

SCR Bridge

Single phase input, asymmetrical 2-SCR half-controlled output.
Single phase input, symmetrical 4 SCR full-controlled output.

Field Failure Relay

Voltage 250V AC, 50V DC

Current 3.5A max.

Switching 1000VA max., 200W max.

INSTALLATION AND SET-UP

MECHANICAL

The FXM5 module must be firmly attached to a vertical surface by the two fixing brackets, Fig.3. The module must be located so that the fins of the heat sink are vertically aligned to permit free circulation of cooling air. Access for cooling air to and from the heat sink must not be obstructed. As supplied, the FXM5 has an integral cover, retained by four screws.

FXM-5 Jumper / Component Locations

The below diagram shows the FXM-5 external, optional field controller with expanded views as shown in figures 1 through 3. Explanations are as follows:

Figure 1. This figure shows the bar-graph display with a scale of 0.1 to 1.0 which is a ratio of current between 1/10 to 100% current output. This bar-graphs display level depends on the settings of the Min and Max field pots or the settings of parameters 0611, 0608, 0609, 0610 in the mentor drive when a ribbon cable is tied to PL1. When a ribbon cable is connected to the FXM-5 the Pots shown in figure 1 are disabled. If the FXM-5 is not connected via ribbon cable the Set max field pot adjusts the max field current. The Set min field pot adjusts the min field current and the Set max voltage pot adjust the armature voltage level for the FXM-5 to start reducing the field voltage from max toward the min field current setting. LED1 lights when the max. field current setting is attained and LED 2 lights when the min. field current setting is attained. SW1 button is used to set the min field level when no ribbon cable is connected to PL1.

Figure 2. This figure shows LK3 and LK2 jumpers . LK3 is always set for HALF. LK2 is set for the max armature voltage level of the motor being controlled. Set the jumper for below or above 470VDC.

Figure 3. This figure shows the LK1 jumper, the DC current transformer and the AC input voltage range jumpers. The settings of these components are explained in the FXM-5 section of this manual. The turns placed through the DC current transformer from F2B through the center of the CT to F2A this is the proper path for the wiring of the current transformer.

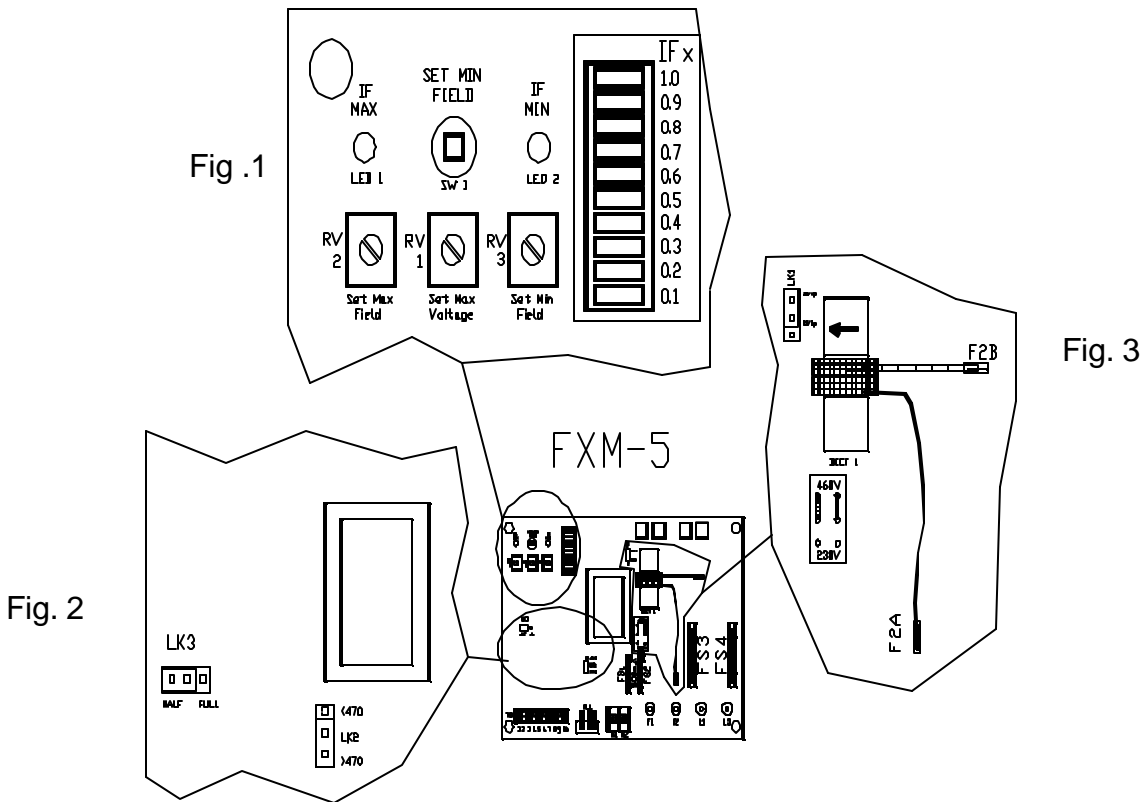

34 Field Setup- FXM5 External Controller

ELECTRICAL

Safety Warning !

Voltage present in the FXM5 can inflict injury and may be lethal. Persons responsible for installing and operating this equipment must be aware of the danger and take due precautions. It is recommended that the equipment SHOULD BE SAFELY ISOLATED before the cover is removed.

1. A single phase AC power supply is connected to terminals L1 and L3. When the FXM5 is to be operated by a MENTOR II DC drive, it is **essential that terminals L1 and L3** are connected to the same phase as terminals L1 and L3 of the MENTOR II.
2. The FXM5 module must be adjusted to accept one of two 50/60Hz supply voltage ranges - either 220V to 254V $\pm 10\%$, or 380V to 440V $\pm 10\%$ (up to 480V + 10% at 60Hz). The control supply must be in phase with the power supply to the SCR's.

The FXM5 PCB is adjusted for the available supply voltage range by means of TWO jumper links. These are located to the right of the transformer in the middle of the PCB.

A low voltage (<220V) field supply cannot be used for control supply. In this case, a separate control supply within the correct voltage range must be provided. REMOVE fuses FS1 and FS2, and connect the control supply to terminals E1 and E3 on the PCB.

IMPORTANT : Ensure that BOTH voltage range selector jumpers are correctly set.

The maximum field current delivered by the FXM5 is determined by the number of primary turns of the DCCT supplied with the module, and by the setting of jumper LK1.

Jumper LK1 can be placed in one of two positions, such that

$$\text{Maximum } I_f = \frac{20}{N_p} \quad \text{or} \quad \frac{15}{N_p}$$

where N_p is the number of DCCT primary turns.

Field Setup-FXM5 External Controller 35

The resulting Max. field current can thus be adjusted to one of 20 different values as listed in the table below:

DCCT Turns	Max I_f with 20/Np	Max I_f with 15/Np
10	2.0	1.5
9	2.2	1.7
8	2.5	1.9
7	2.9	2.1
6	3.3	2.5
5	4.0	3.0
4	5.0	3.6
3	6.7	5.0
2	*10.0	7.5
1	*20.0	*15.0

Note : When field current is greater than 9 Amps, the AC supply fuse FS3 & FS4 must be replaced with 20 Amp fuses (KTK-20), and the 20 gauge primary turns wire for the DCCT must be replaced with 14 gauge wire.

When the FXM5 is controlled by the Mentor II using a 10 conductor ribbon cable, Links LK1 & LK2 located to the right of the F2- terminal on the Mentor II itself will need to be cut to disable the Mentor's internal field loss circuit.

Make sure Parameter 6.22 Full or Half control agrees with FXM5 jumper LK3. Unless the application calls for quick speed changes, it is recommended to use the FXM5 in Half control mode.

When an FXM5 is used while linked to the Mentor II with the ribbon cable, parameter 06.11, DCCT turns and LK1 jumper position should be adjusted per the following table:

36 Field Setup- FXM5 External Controller

Maximum current (A)	Primary turns Np	LK1 jumper position		Parameter 06.11
		20/Np	15/Np	
1	10		X	1
2	10	X		2
3	5		X	3
4	5	X		4
5	4	X		5
6	3	X		6
7	2	X		7
8	2	X		8
9	2	X		9
10*	2	X		10
11*	1		X	11
12*	1		X	12
13*	1		X	13
14*	1		X	14
15*	1		X	15
16*	1	X		16
17*	1	X		17
18*	1	X		18
19*	1	X		19
20*	1	X		20

? When field current is greater than 9 Amps, the AC supply fuse FS3 & FS4 must be replaced with 20 Amp fuses (KTK-20), and the 20 gauge primary turns wire for the DCCT must be replaced with 14 gauge wire.

7. **Armature Voltage Range**

In the case where the FXM5 is used with a Mentor II DC Drive, no connections are required to the A1 and A2 terminals of the FXM5. However, the voltage range jumper, LK2, should still be selected for the correct armature voltage range (whether the feedback voltage would exceeds 470V or otherwise.

8. **Maximum Armature Voltage**

Parameter 3.15 (Max. Arm. Voltage) sets the maximum armature voltage.

9. **Maximum Field Current**

Parameter 6.11 and 6.08 set the Max. Amps Range and Max. Scaling respectively.

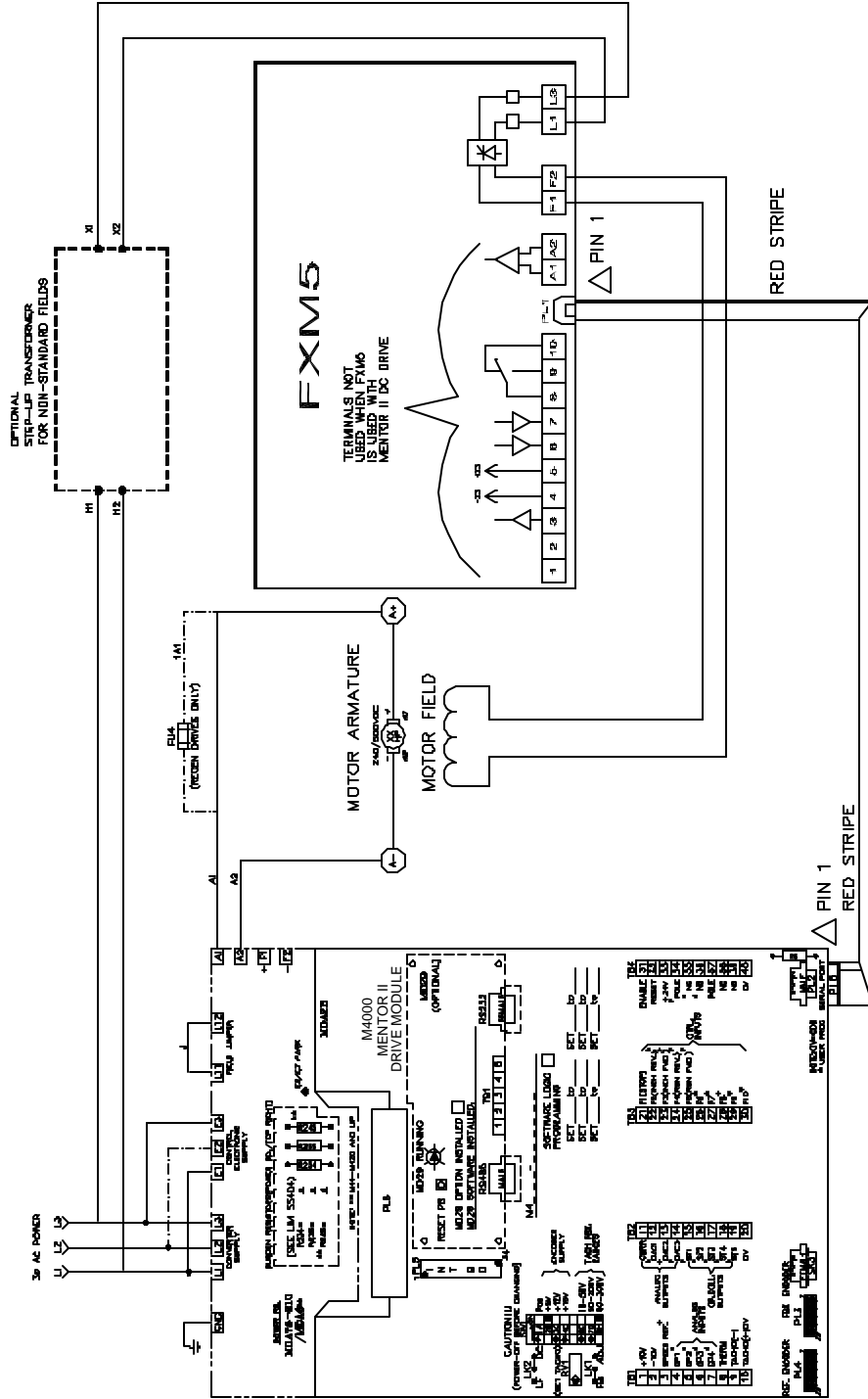

FXM5 CONNECTION DIAGRAM FOR USE WITH M4000 DRIVE
75 HP OR LESS AT 460 VAC AND 40 HP OR LESS AT 230 VAC

Field Setup – FXM5 External Controller 38

FXM5 CONNECTION DIAGRAM FOR USE WITH M4000
100 HP OR GREATER AT 460 VAC, 50 HP OR GREATER AT 230 VAC

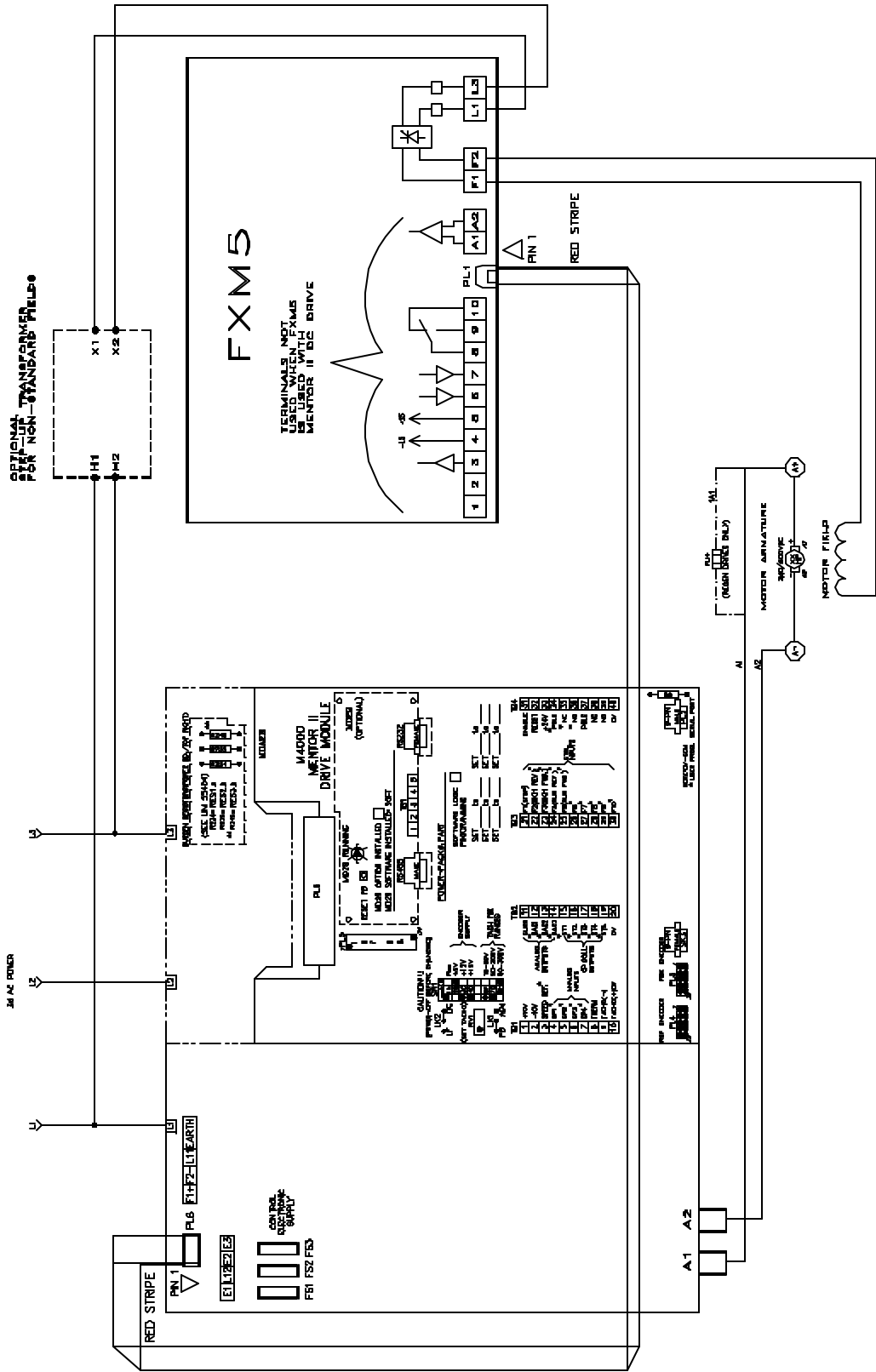

Feedback Selection and Set-Up

Feedback Selection is determined by Parameters 3.12 and 3.13. Parameters 3.12 and 3.13 are bit parameters meaning they have values of either 0 or 1. The table below shows their settings per type of feedback used. Do not change these parameters until asked to do so in the Feedback Set-Up procedures.

Feedback Selection	Parameter 3.12	Parameter 3.13
Armature Voltage	0	1
Tach	0	0
Encoder	1	Don't Care (0 or 1)

A. Armature Voltage Feedback

All standard drives are shipped in armature feedback. Parameter 3.04 has been dedicated in the Mentor II to represent Armature Voltage Feedback (Read-Only). Parameter 3.15 (Max. Armature Voltage) sets the linearity of 0-100% speed demand versus 0-Motor Nameplate Armature Voltage. Ideally, if the final speed demand (Parameter 3.01 = 1000) then Parameter 3.04 (Armature Voltage, Read-Only) should read motor nameplate Armature Voltage and the motor should run at base speed. Often, the speed pot is set for 50 % and it is found that the motor is going too fast or too slow for what is expected. Usually this is because of either 1) the field has not been set-up correctly or 2) Parameter 3.15 (Max. Armature Voltage) has not been set for motor nameplate. Ultimately, speed regulation is verified by monitoring Parameter 3.06 (Speed Error) which is the difference in Final Speed Demand (Parameter 3.01) and Speed Feedback (Parameter 3.02).

Feedback Selection	Parameter 3.12	Parameter 3.13
Armature Voltage	0	1

B. DC Tach Feedback

If an application requires better speed regulation than the 2% provided by Armature Voltage Feedback, then a DC TACH or Encoder must be supplied with the motor. If a DC Tach is used then use the following procedure to calibrate the Tach Scaling to provide correct speed and regulation.

To set up the M4000 for the particular tach generator to be used, the following steps must be followed:

- 1) Turn off power to drive.
- 2) Locate the jumper LK1 and the set of dip switches SW1 located on middle right-hand side of the printed circuit board MDA-2 or MDA-2B (depending on revision level) accessible when the lower pop-off cover of the drive is removed. The LK1 jumper has two settings marked on the circuit board : Feedback and Adjust. The jumper placed in the middle to left pin is the Feedback position and the jumper placed in the middle to right pin is the Adjust position. The dip switches SW1 are mounted vertically and are numbered top to bottom pins 1 to 8.

40 Feedback Selection and Setup

- 3) Place switch SW1 in the appropriate position depending on the rating of the tach-generator and the maximum voltage to be expected at maximum motor speed.

SWI- pin 6	10 to 50V
SWI- pin 7	50 to 200V
SWI- pin 8	60 to 300V

!!!!!! Select one value only !!!!!!!

Note : When selecting the proper tach V/RPM rating, it is important to keep in mind what the maximum speed of the motor will be in the given application.

Example: Max. Speed = 3400 rpm. If a 100V/1000 tach is used, the maximum voltage expected would be 340 VDC. The maximum scaling range is 60 to 300 VDC. This exceeds the 300 VDC limit. In this case a 50V/1000 tach should have been used. There are also cases where the 10 V minimum is violated.

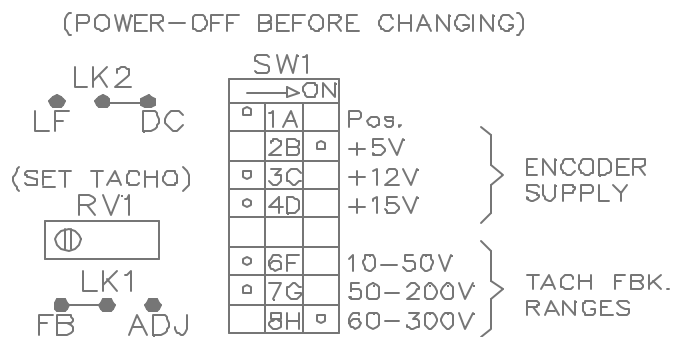

- 4) Connect the tach-generator wires to terminals 1 (-) and 2 (+) on TB4 on the M4000 User Interface board or in the case of a Power Module terminals 9 (-) and 10 (+) on TB1.
- 5) Power up and start motor. Run to 25% speed (still in Armature Voltage Feedback).
- 6) Verify that tach voltage polarity is correct using a digital voltmeter or look at parameter 3.26 (Tachometer Read-Only). If the scaling is scaled properly then $3.26 = 3.02$. Set the voltmeter to DC Volts and place the + lead on TB4-2 of the Interface Board or on TB1-10 of the Power Module. Place the - lead on TB4-1 of the Interface Board or TB1-9 of the Power Module. The voltage reading should be positive.
- 7) Stop motor (Armature Contactor should drop out).
- 8) Set the security code by setting Parameter 0.00 to a value of 200. Verify that 3.12 is set to 0. Select Parameter 3.13, press the "MODE" key (the display will flash). Set 3.13 to 0 and press the "MODE" key to exit.

Feedback Selection and Setup 41

Feedback Selection	Parameter 3.12	Parameter 3.13
Tach	0	0

- 9) Select Parameter 0.00 and press the "MODE" key (the display will flash) . Set the value to 001. Press the "MODE" key to exit and the "RESET" Key to store changes. The display lights will flash indicating a re-boot is taking place).
- 10) Set the LK1 jumper in the Adjust position.
- 11) Select Parameter 3.02. Adjust the RV1(blue pot on MDA-2(B) Board) until the value of 3.02 (Speed Feedback) is:

$$\text{Parameter 3.02} = - (10000 / V_{\text{max}})$$

where V max is tach voltage at full speed.

For a 50V/1000 tach on a 1750 RPM motor, Parameter 3.02 should be set to -114. For a 100V/1000 tach on a 1750 RPM motor, Parameter 3.02 should be set to -57.

- 12) Set Jumper (link) LK1 in the Feedback position. It is important to note that when the LK1 jumper is in the adjust position the RV1 pot serves as a coarse Tach Feedback Scaling adjustment. However if the LK1 jumper is placed in the Feedback position then the RV1 pot serves as a fine Tach Feedback Scaling adjustment. Note that LK2 can be used as a filter when a noisy tach exists. The DC position on LK2 provides no filtering and the LF position activates the filter.
- 13) Start motor and fine tune RV1 with motor running at 50% speed. Parameter 3.04 (Armature Voltage RO) should read 50% of maximum Armature Voltage (Parameter 3.15). Also, measuring the DC voltage coming back from the tach to the drive, the voltmeter should read 50% of the expected voltage at full speed (Vmax).

An alternate way to set the drive up for tach feedback is:

- 1) Run the drive in Armature Voltage Feedback at 50% speed for example. At this point 3.01=500 and 3.02=500.
- 2) Adjust RV1 until the value of 3.26 = 500. Stop the drive.
- 3) Change 3.13 = 0 and run in Tach Feedback up to 50% speed. Check the Armature Voltage (Parameter 3.04) such that it reads ½ nameplate voltage.

42 Feedback Selection and Setup

C. Encoder Feedback

Encoder Specs For The Mentor II DC Drive

Type: Incremental 600 pulses per revolution preferred (V+, COM, A, B, A NOT, B NOT). Programmable for 60 to 2048 pulses per revolution. 2 channel quadrature with differential complements (A NOT, B NOT). Power Supply, 5V/12V/15V, 300 mA max. Max Frequency, 200 kHz.

Encoder Set-Up Procedure

- 1) Ensure that the drive is correctly wired and calibrated by running the motor in ARMATURE VOLTAGE FEEDBACK first.
- 2) **TURN OFF AC POWER** and connect the encoder to the SK3 9-pin (D SUB) connector on the MDA-2(B) board. The pin out shown in the table and diagram below. Please note that the C and C NOT connections should NOT be connected unless the Spindle Orientation special application software is used.

Connections

Terminal Block Diagram

Pin #	SK3
1	0V
2	Supply
3	A
4	A NOT
5	B
6	B NOT
7	NC
8	C
9	C NOT

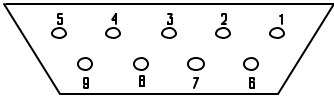

Feedback Selection and Setup 43

An alternative connection for encoder feedback is the 10 pin ribbon connection PL3. The connections for PL3 are as follows. This connection is typically used in Master/Follower or Shaft-Lock Applications.

Pin #	PL3
1	0V
2	Supply
3	A
4	A NOT
5	B
6	B NOT
7	NC
8	C
9	C NOT
10	0V

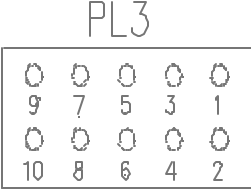

- 2) Check the encoder nameplate for the Encoder Voltage Supply ratings (typically there is a range. i.e. + 5-26 VDC). Set one of the following dipswitches on SW1 to a voltage that is within the encoder's nameplate specs.

SWI-2 +5 volts
 SWI-3 +12 volts
 SWI-4 +15 volts

!!!!!!! Only one value can be selected !!!!!!!!

- 3) Power up the drive and set the security code by selecting Parameter 0.00 and pressing the "MODE" key (the display will flash). Set the value of Parameter 0.00 to 200 and press the "MODE" key to exit.
- 3) Select Parameter #3.12 and press the "MODE" key (the display will flash). Set Parameter 3.12 to 1. Select Parameter #3.13, press "MODE" key (the display will flash), set #3.13 to 0 and press the "MODE" key to exit.

Feedback Selection	Parameter 3.12	Parameter 3.13
Encoder	1	Don't Care (0 or 1)

- 5) To set the Encoder Feedback Scaling, select Parameter 3.14 and press the "MODE" key (the display will flash). Set the value of Parameter 3.14 based on the maximum speed of the motor and the number of lines-per-revolution of the encoder. To calculate the Encoder Feedback Scaling use the following formula :

$$\text{Encoder Feedback Scaling (3.14)} = (750 \times 10^6) / (N \times n)$$

where N = number of lines per revolution (encoder) and n = max speed of motor in rpm.

44 Feedback Selection and Setup / Extended Speed Range

The default value of 419 for Parameter 3.14 is based on a 1024 line (ppr) encoder and a maximum speed of 1750 r.p.m. For a 600 line (ppr) encoder on a 1750 r.p.m. motor the value for Parameter 3.14 is 714.

- 6) Store changes by selecting Parameter 0.00 and pressing the "MODE" key (the display will flash). Set the value of Parameter 0.00 to 001 and press the "MODE" key to exit. Press the "RESET" key and the display will cycle through its boot-up routine.

Make sure the speed pot or speed reference is set to zero and start the drive. Increase the speed demand (via pot or reference) and the motor should accelerate smoothly and speed should be regulated. Be sure to check Armature Voltage at 50% speed. If necessary scale 3.14 so that Parameter 3.04 reads 50% motor nameplate voltage.

Extended Speed Range (Field Weakening)

!!!!!!!!!!!!Caution !!!!!!!!!!!

Always use Tach or Encoder feedback when extending the motor's speed beyond base speed OR excessive motor RPM and possible motor damage may occur.
--

Two criteria must be met before attempting field weakening :

- 1) A feedback device such as a tachometer or encoder must be used.
- 2) The motor must be specified by the motor manufacturer as a motor that can be field weakened. A motor that can be field weakened typically has a nameplate where two speeds are listed (i.e. 1750 / 2300 RPM). Contact your motor supplier or manufacturer if you are unsure whether your motor is designed for this application or not.

Extended Speed Range 45

Procedure:

- 1) Acquire the motor's nameplate data. This includes :
 - a) Max. Field Amps
 - b) Min. Field Amps
 - c) Base Speed
 - d) Top Speed
 - e) Armature Voltage
 - f) Field Voltage
 - g) Tachometer or Encoder Used ?
If so, V / RPM ratio (tach) or PPR (encoder) ?

A typical motor nameplate is shown below.

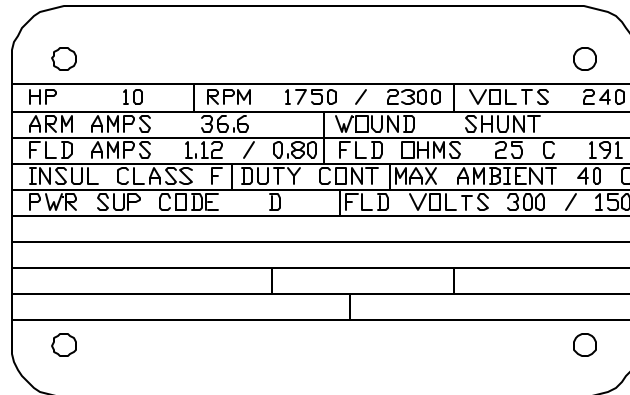

HP	10	RPM	1750 / 2300	VOLTS	240
ARM AMPS	36.6	WOUND	SHUNT		
FLD AMPS	1.12 / 0.80	FLD OHMS	25 C	191	
INSUL CLASS	F	DUTY CONT	MAX AMBIENT 40 C		
PWR SUP CODE	D	FLD VOLTS	300 / 150		

Using the example above, the nameplate data list can be read as:

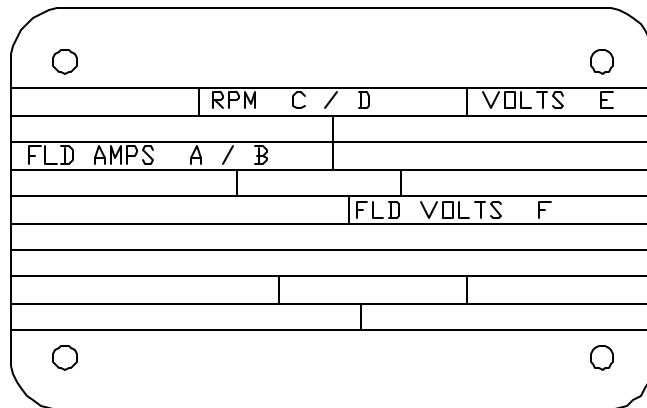

RPM		C / D	VOLTS			E
FLD AMPS		A / B				
			FLD VOLTS			F

46 Extended Speed Range

- 1) Understand the nameplate information.

Using the example above,

- a) Max. Field Amps = 1.12 for a 300 VDC Field, 2.24 for a 150 VDC Field (double nameplate)
- b) Min. Field Amps = 0.80 for a 300 VDC Field, 1.60 for a 150 VDC Field (double nameplate)
- c) Base Speed = 1750 RPM
- d) Top Speed = 2300 RPM
- e) Armature Voltage = 240 VDC
- f) Field Voltage = 300 / 150 VDC
- g) Tachometer or Encoder Used ? Assume a tach.
If so, V / RPM ratio (tach) or PPR (encoder) ? Assume 50V/1000 RPM or 600 PPR.

Since the Armature Voltage is 240 VDC, the AC line input for the drive would typically be 230 VAC
3 phase and the Field Voltage would be 150 VDC.

- 2) Understand the two field ranges.

- a) Constant Field Ranges (motor runs from standstill to base speed)
- b) Field Weakening or Extended Speed Range (motor runs from base speed to top speed)

If the drive is set for a constant field (with no field weakening), then using our example, the MDA3 or FXM5 (Menu 6) is set up so that max. field amps are applied to the field windings. In this case, 2.24 A is applied to the field windings and the field voltage results in approximately 150 VDC. As your speed demand goes from 0 to 100 % it will result in 0 to Base Speed RPM on the motor. If the field is set-up correctly then the Armature Voltage at 100 % Speed Demand should be 240 VDC. At 240 VDC on the armature the motor runs at 1750 rpm (+/- 7% as defined by the motor manufacturer specifications) .

If the application requires the top speed of 2300 rpm then the field must be weakened. Again, using the example above, if the field amperage is reduced to 1.60 A and 240 VDC on the armature is applied, then the motor is expected to run at 2300 rpm (+/- 7% as defined by the motor manufacturer specifications).

The graphs below show Armature Voltage Vs. RPM and Field Amps Vs. RPM.

Extended Speed Range 47

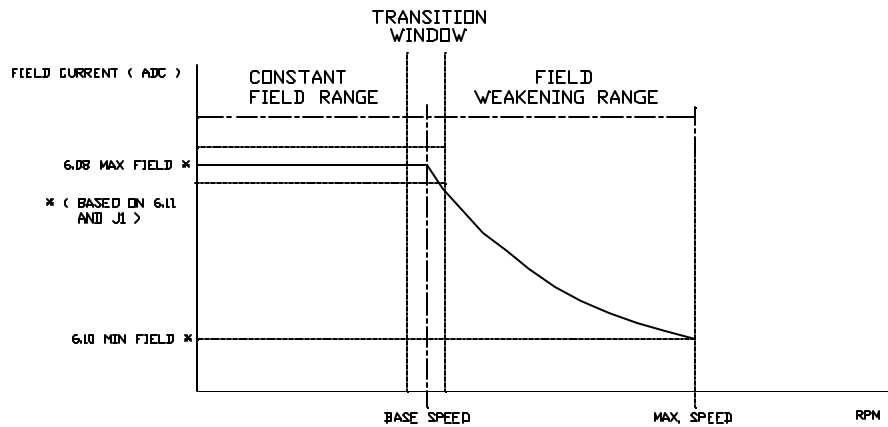
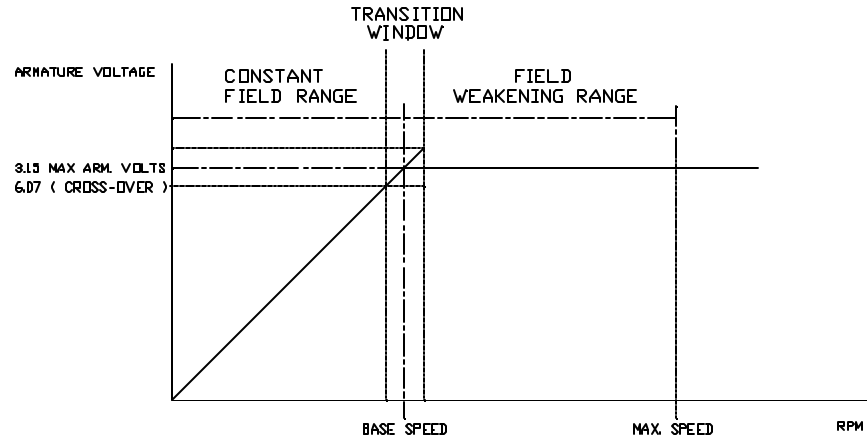

- 1) Run the drive in Armature Voltage Feedback with a constant Field and verify that:
 - a) 0 to 1000 in 3.01 (Final Speed Demand) = 0 to Max. Arm. Volts in 3.04 (Armature Voltage Read-Only).
 - b) 0 to Max. Arm. Volts in 3.04 (Armature Voltage Read-Only) = 0 to Base Speed

In our example, 0-240 in 3.04 = 0 to 1750 RPM +/-7 %. Note that the MDA3 or FXM5 section of the manual describes setting the field controller for constant field.

- 5) Stop the drive.

48 Extended Speed Range

- 6) Power down.
- 7) If using the MDA3 internal controller, verify that the J1 jumper on the MDA3 is set for the correct field range. This is either the 2A position (left) or the 8 A position (right). In our example, the J1 jumper would be set for the 8 A position (right) since the max. field current of 2.24 is higher than the 2 A range. Note: This should have already been done per setting the field controller for constant field (see Step 4 above).
- 8) Power up the drive.
- 9) Statically, setup Menu 6 (Field Control Menu).
 - a) Scale the field range, P6.11, according to the tables provided in the Field Set-Up section of this manual. Which table is used depends on whether the field current regulator is the MDA3 or the FXM5 (with ribbon cable to Mentor). Note: This should have already been done per setting the field controller for constant field (see Step 4 above). In our example above, 6.11 would be set for 206.
 - b) Set parameter 6.08 such that

$$6.08 = \frac{\text{MAX. FIELD CURRENT (MOTOR NAMEPLATE)}}{\text{FIELD RANGE AMPS (PER TABLE)}} \times 1000$$

In the example, the max. field amps equals 2.24 and the field range amps per the Table in the MDA3 or FXM5 section of the manual equals 3.0 amps.
Therefore,

$$6.08 = (2.24 / 3.0) \times 1000 = 747$$

- 10) Set the min. field current parameter 6.10 where
In the example, the min. field amps equals 1.60 and the max. field amps equals 2.24.

$$\text{CALCULATED MIN.} = \frac{\text{MIN. FIELD CURRENT (MOTOR NAMEPLATE)}}{\text{MAX. FIELD CURRENT (MOTOR NAMEPLATE)}} \times 6.08$$

$$6.10 = \text{CALCULATED MIN.} \times 0.9$$

Therefore,

$$\text{Calc. Min.} = (1.60 / 2.24) \times 747 = 534$$

$$6.10 = 534 \times 0.9 = 480$$

The calculated min. is multiplied by 90 % to provide for a margin of error so that the top speed of the Motor will not be limited by the field being too strong.

Extended Speed Range 49

- 11) The cross-over point is defined as the level where the motor is at base speed and any request for more speed will result in weakening of the field current to attain higher or top motor speeds.

$$\text{Cross-Over Point} = \text{Base Speed in Mentor Units} = (\text{Base Speed} / \text{Top Speed}) \times 1000$$

In the example,

$$\text{Cross-Over Point} = \text{Base Speed in Mentor Units} = (1750 / 2300) \times 1000 = 761$$

Set parameter 6.07(Back EMF Set-point) equal to:

$$\text{Parameter 3.15 (Max. Armature Voltage)} \times 0.98$$

In the example, $6.07 = 240 \times 0.98 = 235$.

- 12) Make sure that SW1 (8 dip switches located on the MDA-2 or MDA-2B board) is properly set for the correct voltage range (10-50 V/ 50-200 V/ 60-300 V) if a tach. is used or the correct encoder supply voltage (+5/+12/+15) is set if an encoder is used. Note: Power down before making any dip switch setting changes.
- 13) Adjust the drive's speed reference until parameter 7.05 reads 761.
- 14) With the drive still set for armature voltage feedback, run the drive until the speed is at steady state. Parameter 3.01 (Final Speed Demand) should equal 761 and parameter 3.02 should equal 761 +/- 2 %.
- 15) If using a tach. adjust the RV1 pot on the MDA-2 or MDA-2B board while monitoring parameter 3.26 (Tach. Feedback Read Only) until parameter 3.26 = parameter 3.02. If using an encoder set parameter 3.14 such that:

$$3.14 = (750,000,000) / (n \times N)$$

where N = number of lines per revolution (PPR) and n = top speed of the motor in RPM.

For more details regarding tach or encoder feedback scaling refer to the Tach Feedback or Encoder Feedback sections of the manual.

- 16) Stop the drive and set parameter 3.13 to 0 if using a tach to set the drive for tach feedback. If an encoder is used, set 3.12 to 1 to set the drive for encoder feedback.
- 17) When first running the Motor, check the RPM at 1/2 maximum speed before continuing to full speed.
- 18) While monitoring parameter 3.04 (Armature Voltage Feedback), adjust the tach feedback scaling Pot (RV1 located on the MDA-2 or MDA-2B board) so that parameter 3.04 = parameter 6.07. At this point 6.02 (Final Field Current Demand) is approximately equal to 6.03 (Field Current Feedback). This is where the cross-over point occurs and the motor should be running at base speed. Increasing the speed demand will result in the field current decreasing.

50 Extended Speed Range

- 19) Slowly adjust the speed demand (parameter 7.05 and parameter 3.01) by 50 Mentor units (5%) and monitor both parameters 3.04 (Armature Voltage Feedback) and 6.03 (Field Current Feedback).

Note:

- ? Parameter 3.04 (Armature Voltage Feedback) should stay constant
- ? The Speed Feedback (3.02) should increase by 5 % or 50 Mentor units
- ? Parameter 6.03 (Field Current Feedback) should decrease.
- ? If it is safe and possible, use a digital hand-tach and verify motor speed while running

- 20) Slowly increase the speed demand (parameter 7.05) while continuing to monitor parameters 3.04 (Armature Voltage Feedback), 3.01 (Final Speed Demand), 3.02 (Speed Feedback), and 6.03 (Field Current Feedback). Using the example:

- ? 3.04 should equal approximately 235 to 240 without continuing to increase
- ? 3.01 should equal 3.02 +/- 2 %
- ? 6.03 should decrease toward the setting in parameter 6.10 (Min. Field Current).

If parameter 3.04 begins to rise over the setting in parameter 3.15 (Max. Arm. Voltage) while increasing the speed demand then lower parameter 6.10 (Min. Field Current) by 10 counts. Parameter 3.04 should return to regulating within 235 to 240.

- 21) Once the speed demand (parameter 7.05 and parameter 3.01) equals 1000 then the motor RPM should be at or above the nameplate Top Speed. In our example, Top Speed is equivalent to 2300 RPM.

If safe and possible, verify the motor RPM using a digital hand-tach.

If top speed has not been reached, decrease parameter 6.10 (Min. Field Current) by 10 counts
And monitor 3.04 (Armature Voltage Feedback) to make sure it continues to stay constant.
Repeat
(if necessary until Top Speed has been reached).

Reference Setup

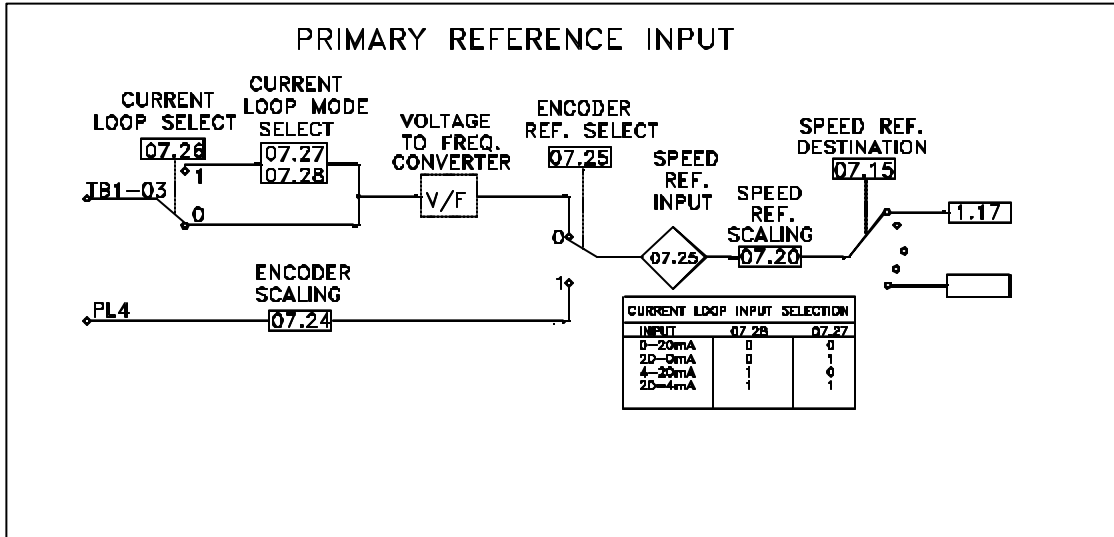

A. Speed Potentiometer (Analog Pot)

TB1-3 on the power module or TB4-7 on the interface board is the wiper input for a master speed pot. Note that TB1-1 and TB1-2 on the power module or TB4-4 and TB4-5 on the interface board are +10 VDC and -10 VDC power supplies intended for use with a speed potentiometer. The default settings set the input for a voltage reference. Scaling can be accomplished by using parameter 7.20 where 1000 = 100.0%. This input has 12 bit accuracy 0-4096. The Speed Reference Destination is set for 1.17, Speed 1 Reference. For additional information refer to Menu 1 Speed Reference flowchart.

B. Voltage Speed Reference (0-10 VDC Line Speed)

Similar to using a speed pot (as mentioned above), a line speed signal (normally 2 wire shielded twisted pair) can be used to control the speed of the M4000. The + wire is wired to TB1-3 on the power module or TB4-7 of the interface board and the - wire is wired to TB1-10 of the power module or TB4-12 of the interface board.

C. Current Speed Reference (0-20 mA or 4-20 mA Line Speed)

Parameter 7.26 when set to a 1 changes the primary speed reference input from a voltage to a current input. Depending on the current input type (i.e. 4-20mA or 20-4mA), parameters 7.27 and 7.28 are used in tandem to set the mode for current reference. Use the table in the diagram to set the mode that applies to your application.

52 Reference Setup

D. Encoder Reference (Following A Pulse Train)

Type: Incremental 600 pulses per revolution preferred (V+, COM, A, B, A NOT, B NOT).
 Programmable for 60 to 2048 pulses per revolution. 2 channel quadrature with differential complements (A NOT, B NOT). Power Supply, 5V/12V/15V, 300 mA max.
 Max Frequency, 200 kHz.

The 10 pin connection on the MDA-2B terminal I/O board PL4 provides an input in the case where the line speed signal is an encoder . The diagram below shows the connection pinout for PL4.

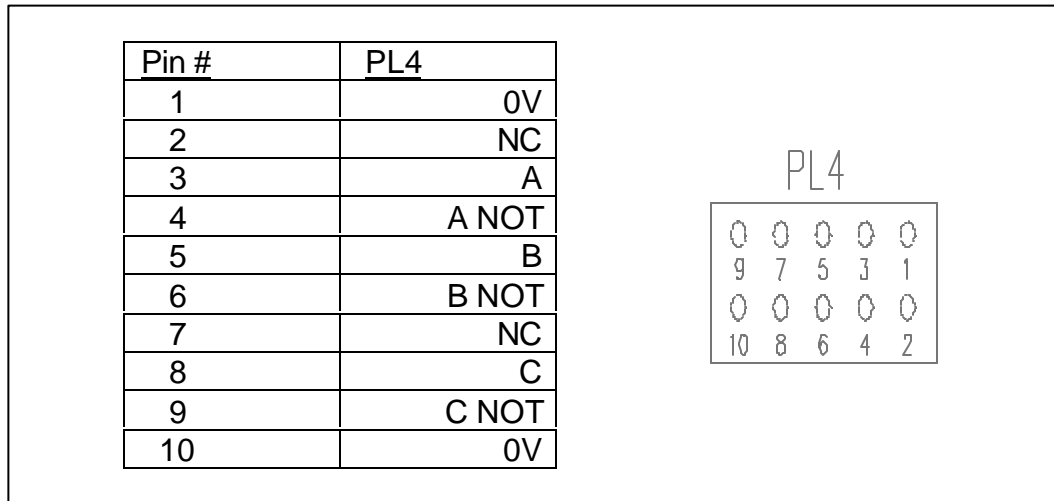

As with Encoder Feedback, the **C and C NOT channels are NOT used unless the application involves the Spindle Orientation special application software.**

By referring to the programming flowchart above, the following Parameters are used to set the M4000 for Encoder Reference Mode.

Parameter #	Description	Parameter Value
07.15	Speed Ref. Destination	0117
07.20	Speed Ref. Scaling	1000
07.24	Encoder Ref. Scaling	$= (750 \times 10^6) / (N \times n)$ where N = number of lines per revolution (encoder) and n = max speed of motor in rpm. (= 714 for a 600 PPR encoder and 419 for a 1024 PPR encoder)
07.25	Encoder Ref. Enable	1

Please refer to the Menu 7 parameter descriptions in the appendices of the manual for more details.

Initial Parameter Programming

A. Introduction

Now that a successful start-up has been completed, it is time to fine-tune the M4000 to your application. In many cases, performance with initial adjustments is acceptable, and quite possibly no further adjustments need be made. However, it is advisable that the following steps be taken to assure that the M4000 is performing to its potential in the application.

Take a few minutes to read over the following lists of parameters which are available for your use.

B. Operational Parameters (The Zero Menu)

The operational parameters described in this section may be adjusted by the operator to more closely tailor the M4000 to the application. For initial startup, it is recommended that original factory settings not be altered.

For many applications the parameters available in the User Menu 00 are all that are required to successfully operate a Mentor M4000 DC motor controller. These User Menu parameters are:

PARAMETER	FUNCTION	DEFAULT
0.00	SECURITY	
0.01	SPEED SETPOINT	
0.02	MAXIMUM SPEED	1000
0.03	MINIMUM SPEED	000
0.04	ACCELERATION TIME	+050
0.05	DECELERATION TIME	-050
0.06	CURRENT LIMIT FORWARD	+1000
0.07	CURRENT LIMIT REVERSE	+1000
0.08	JOG/INCH	+050
0.09	IR COMPENSATION	000
0.10	SPEED LOOP RESPONSE	080

54 Initial Parameter Programming

For additional information on the zero menu please refer to the Appendix I and II (Menu Flowcharts and Parameter Descriptions.

C. Initial Operation Monitoring

Once the M4000 has been correctly installed, wired, and started up, normal operation can begin. Whenever the M4000 is powered up, it will retain all parameter values stored previously. Therefore, it is not necessary to check or change anything once initially set up.

Normal Running Indications

When the M4000 is performing normally, the following DRIVE STATUS LED's will illuminate steadily for the various conditions:

- 1) Power on, stopped : DRIVE READY, ZERO SPEED.
- 2) Accelerating to speed: DRIVE READY, BRIDGE 1 (or 2), and RUN FORWARD (or REVERSE)
- 3) Running: DRIVE READY, BRIDGE 1 (or 2), RUN FORWARD (or REVERSE) and AT SPEED.

It may be normal to see the CURRENT LIMIT LED flicker briefly while accelerating or decelerating. This is not a sign of a harmful condition, though it can be eliminated by increasing the ACCELERATION or DECELERATION RAMP TIME.

When the M4000 is operating normally, speed changes will be smooth, and new speeds will be reached without overshoot or oscillation. The properly sized and programmed M4000 should be capable of starting with the speed pot in any position, and accelerating to the set speed without tripping or overloading.

Drive Status Parameters

A very useful group of data is available at any time to the operator in the form of DRIVE STATUS PARAMETERS. They can be displayed, but not changed or programmed. To access these parameters, see section 3.5.4. The parameters may be scrolled through and their values, or data, examined. Following is a list of each parameter.

1.17 - Analog Speed Reference - Displays the value of the reference input to terminal 5 on Drive Module, where -1000 = -10 volts, 1000 = 10 volts.

3.01 - Final Speed Demand – Shows final speed demand.

3.02 - Speed Feedback - This parameter is the value of feedback voltage, either from tach generator or armature voltage, depending on which is selected.

3.06 - Speed Error - Shows the difference between final speed demand (Parameter 3.01) and Speed Feedback (Parameter 3.02).

4.02 - Current Reference - This parameter is the input to the current loop algorithm when in speed control mode. It is a result of the speed loop algorithm acting on the speed error signal (Parameter 3.06) 1000 = Max current limit set by burden resistors.

5.01 - Current Feedback - The scaled output of current transformers on the three phases feeding the SCR bridge(s), and reflecting the current ultimately used by the motor. Feedback of 0 to 1.6 V results in 0 to 1000 reading.

These Drive Status Parameters normally give a "Real-time" display of the various operations going on within the drive. Any parameter may be monitored during normal running operation if desired.

If a Fault Trip occurs, all Drive Status Parameters are "frozen" at their instantaneous values at the time of the fault. These values will be retained until the reset button is pressed, or if power is removed and re-applied. These frozen parameters can provide very useful information about WHY the fault occurred. For example, it is possible to find out exactly where the speed pot was set (Parameter 1.17), how much current the motor was using (Parameter 5.01), and how far the actual motor speed was from the speed set by the operator (Parameter 3.06). Also, a history log of the last 4 faults that have occurred are stored in Menu 10. Please refer to parameter 10.25, 10.26, 10.27, and 10.28 for the fault number codes of the last 4 faults. Fault number codes and mnemonics are explained in the troubleshooting guide at the end of the manual in the Appendices.

To verify proper operation refer to the following control logic overview. Use this flowchart to view pertinent parameters during run-time. When calling DANAHER MOTION ENGINEERED SYSTEMS CENTER for technical assistance please have the values of these parameters both in the stopped mode and while running. If the drive is faulting and you are unable to resolve the issue, have the list of the last 4 fault codes at hand as well.

56 Flowcharts

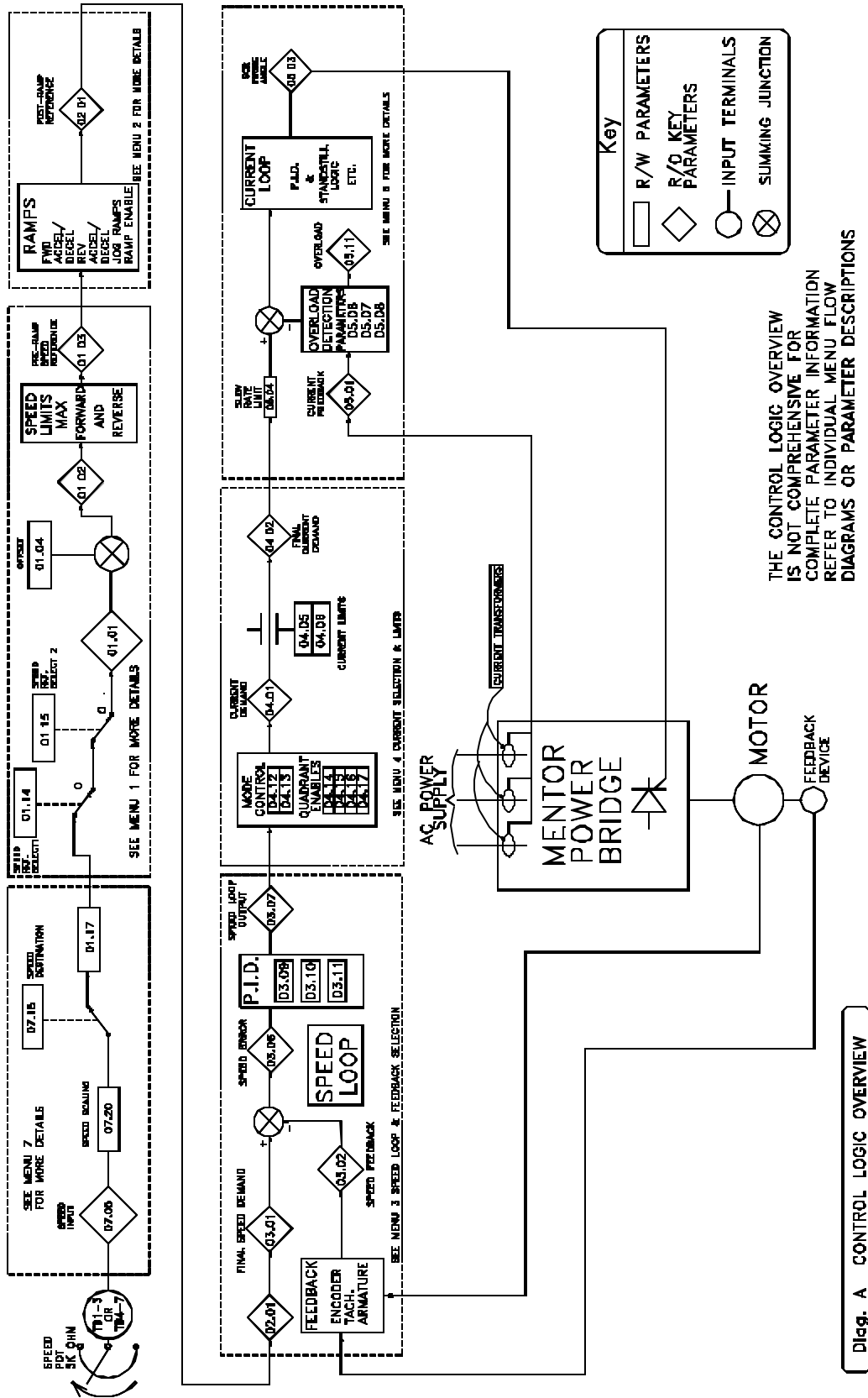

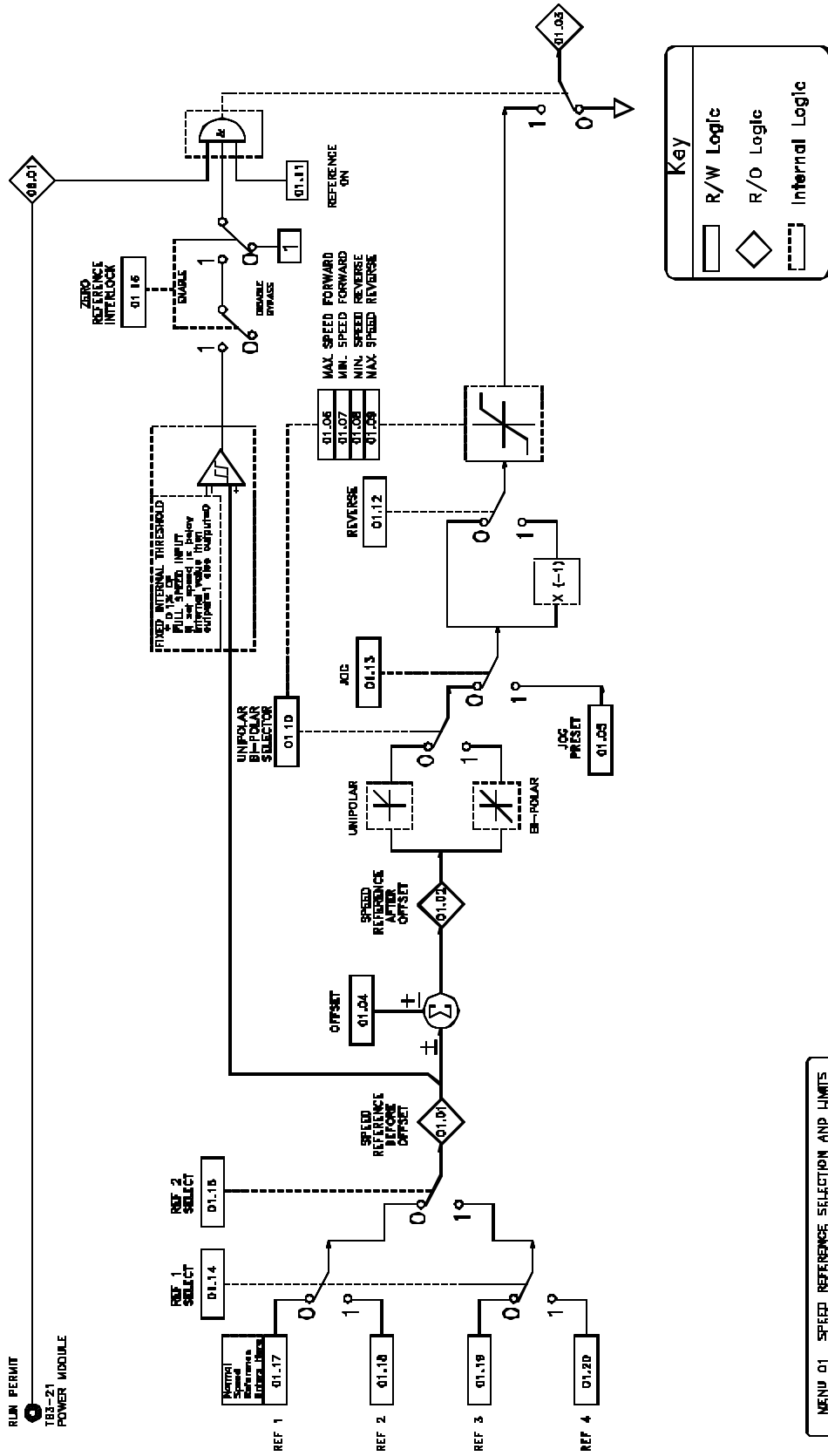

MENU 01 SPEED REFERENCE SELECTION AND LIMITS

58 Flowcharts

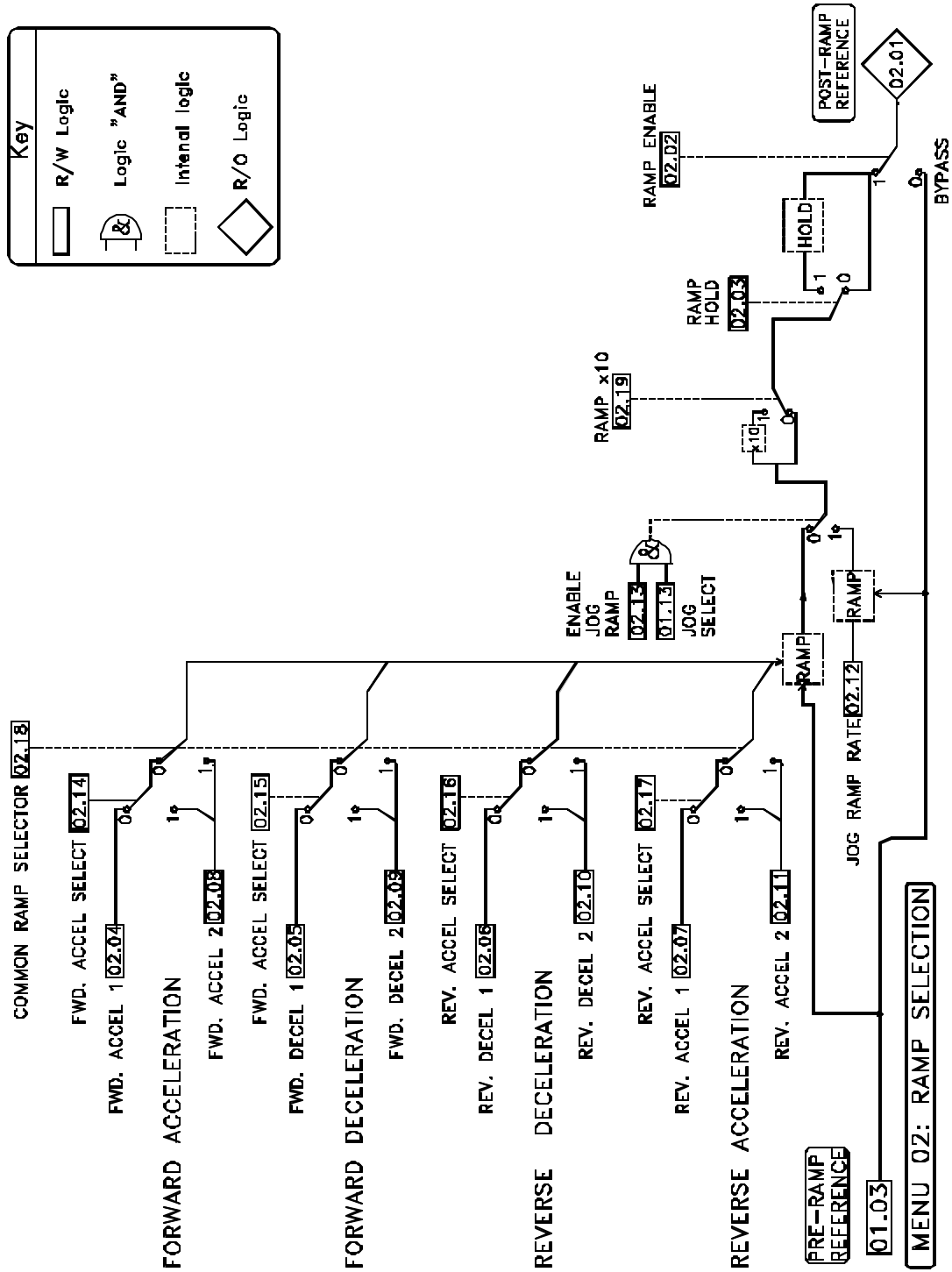

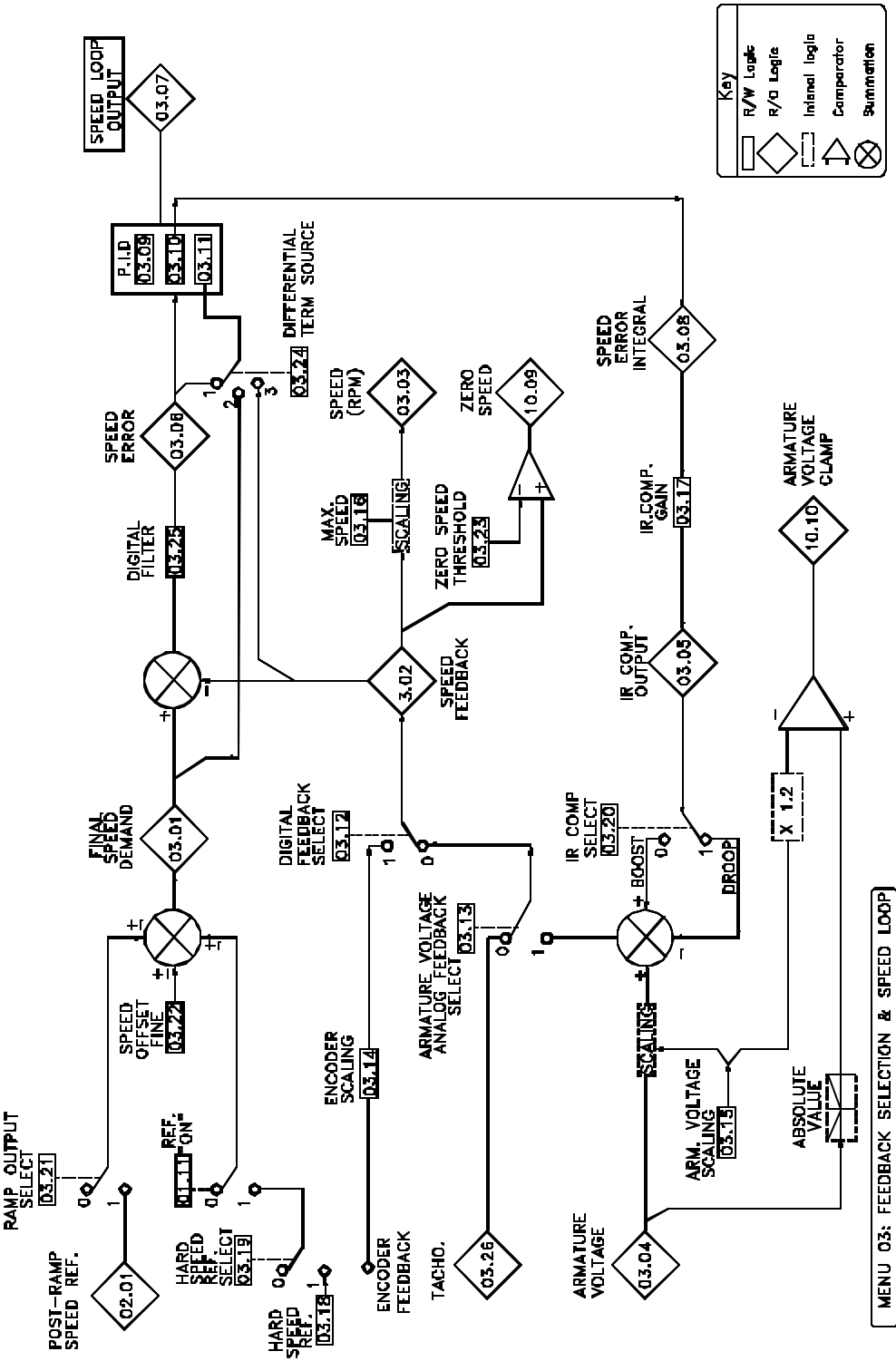

MENU 03: FEEDBACK SELECTION & SPEED LOOP

60 Flowcharts

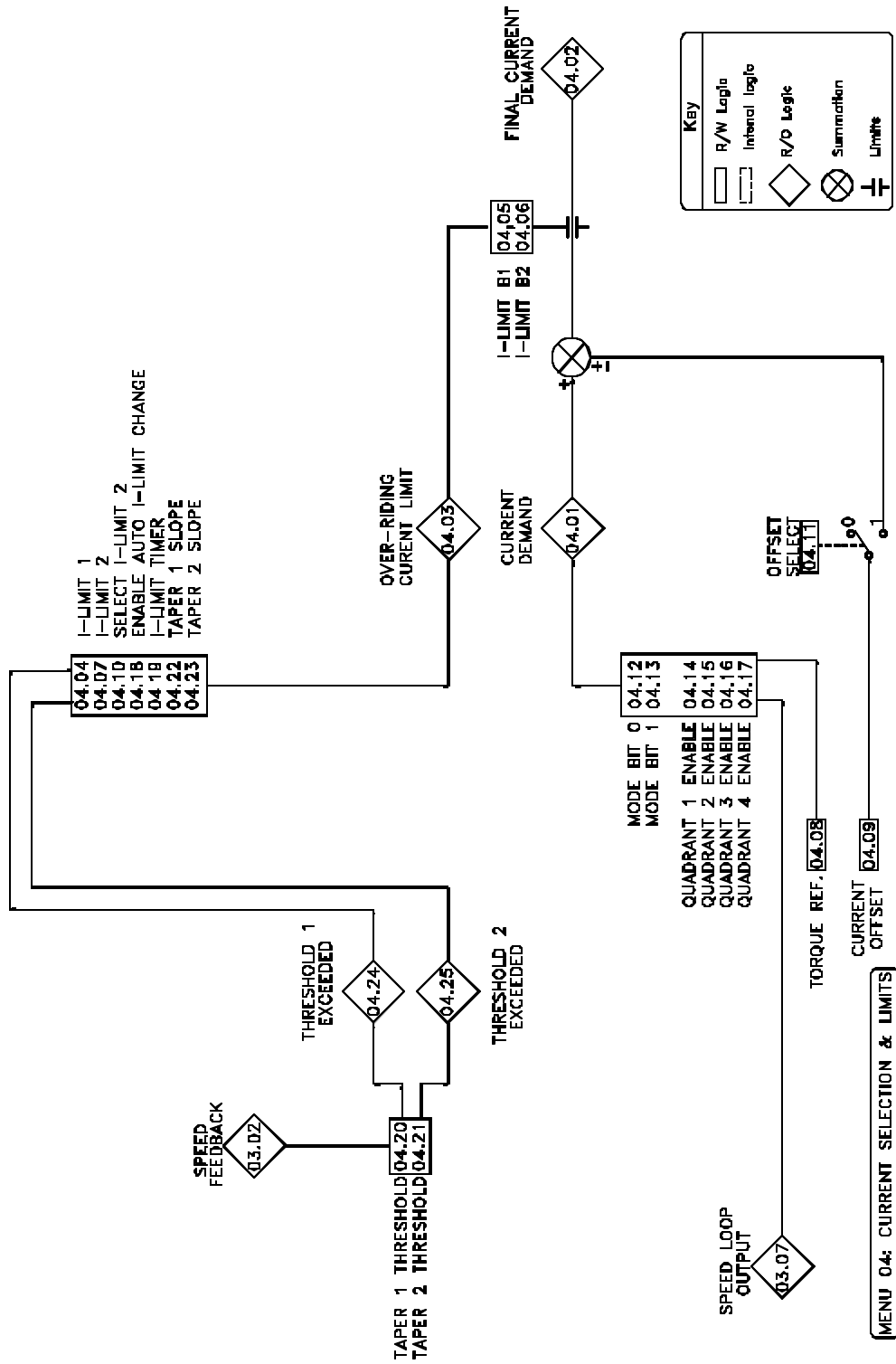

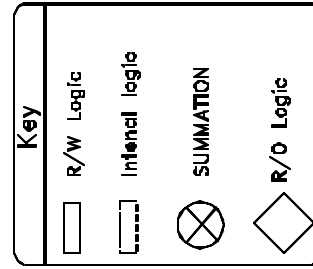
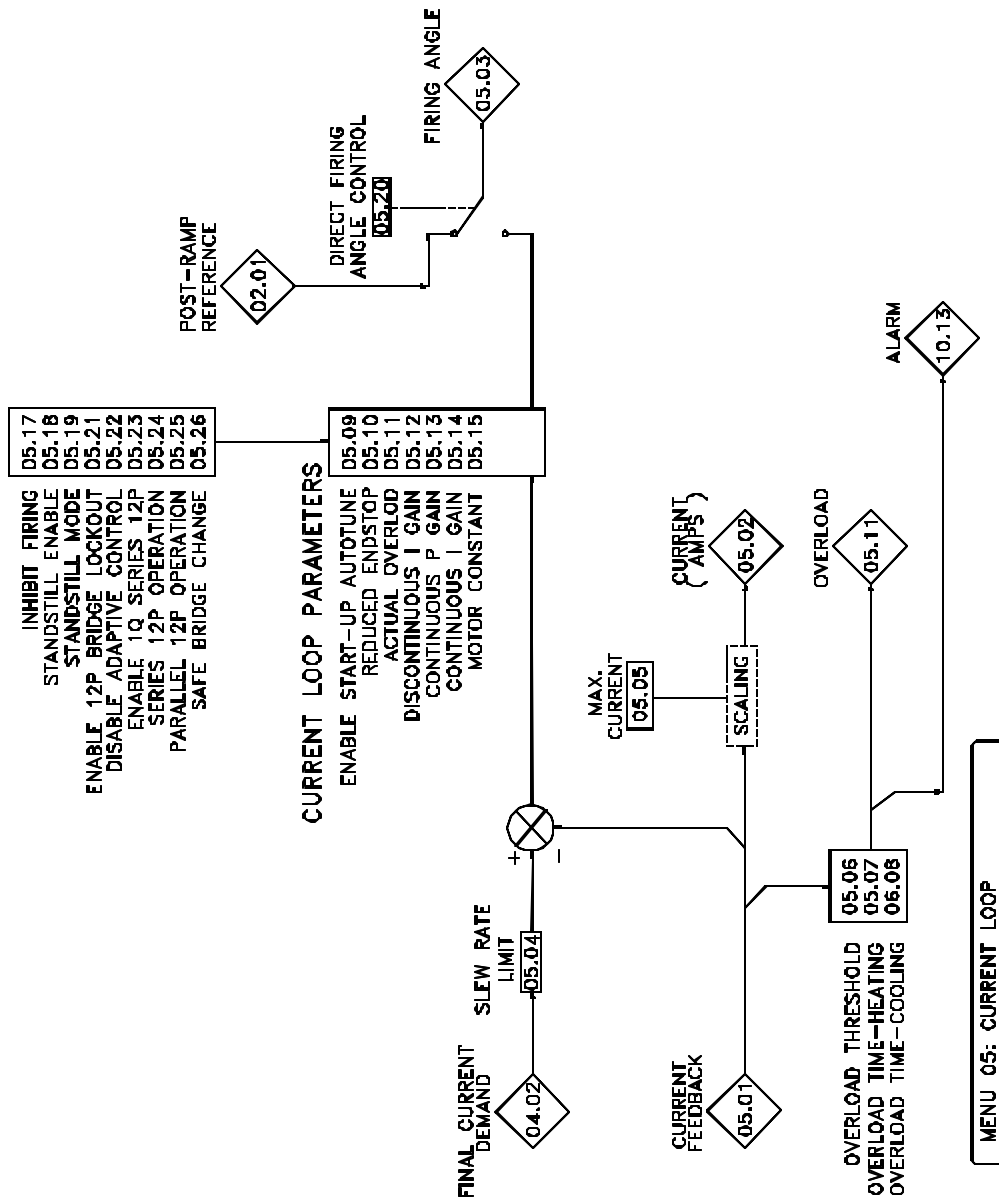

62 Flowcharts

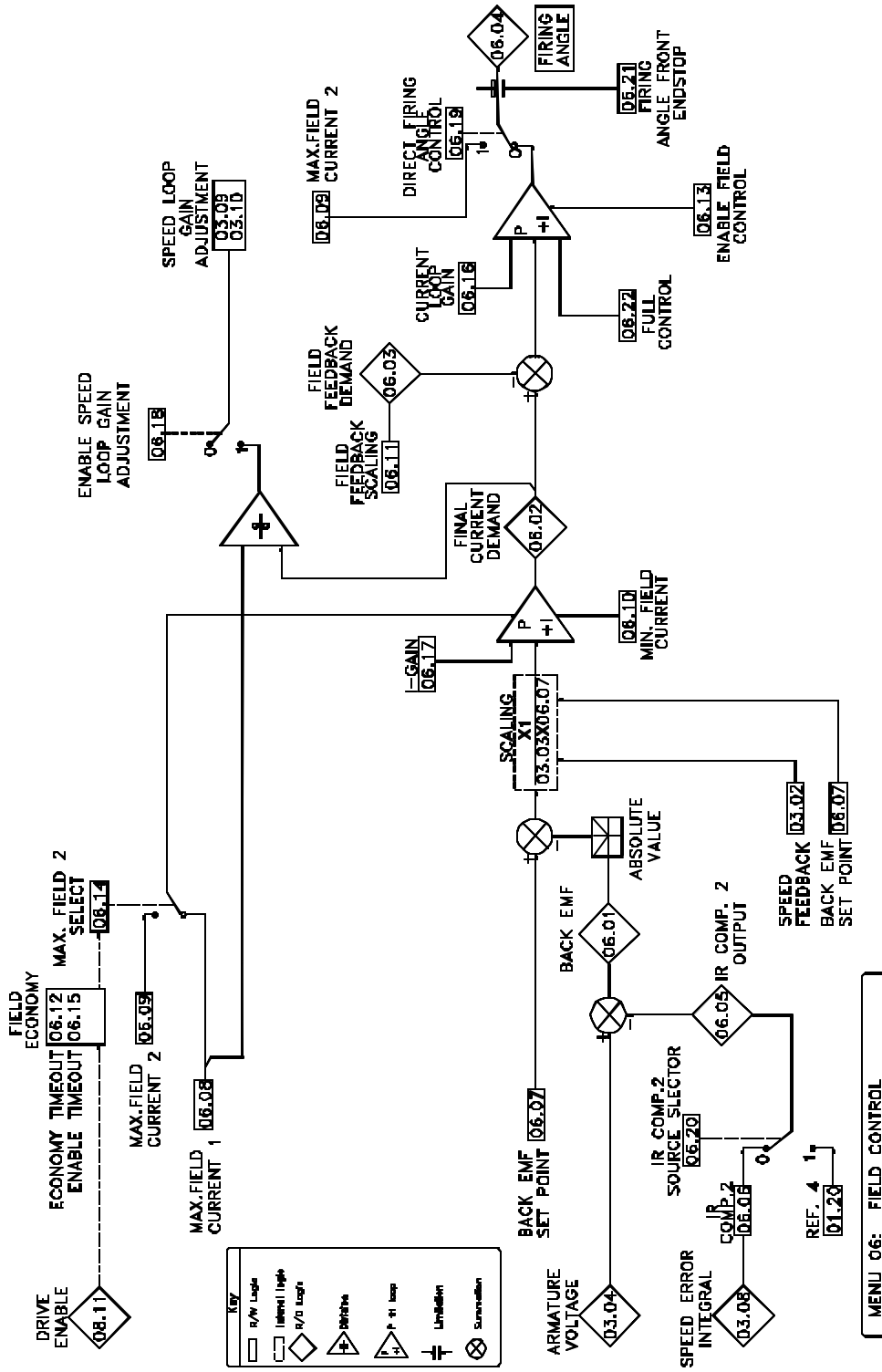

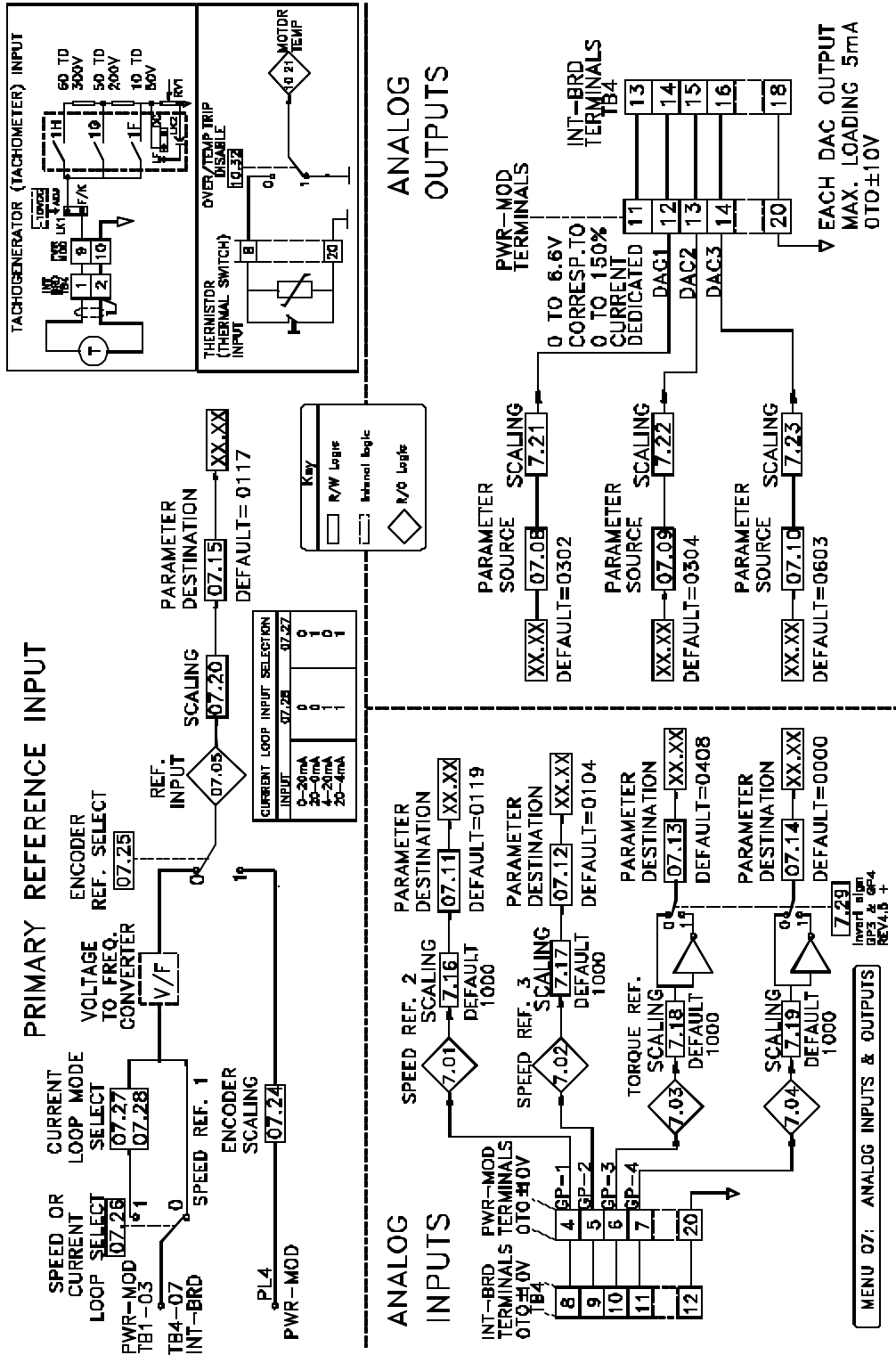

64 Flowcharts

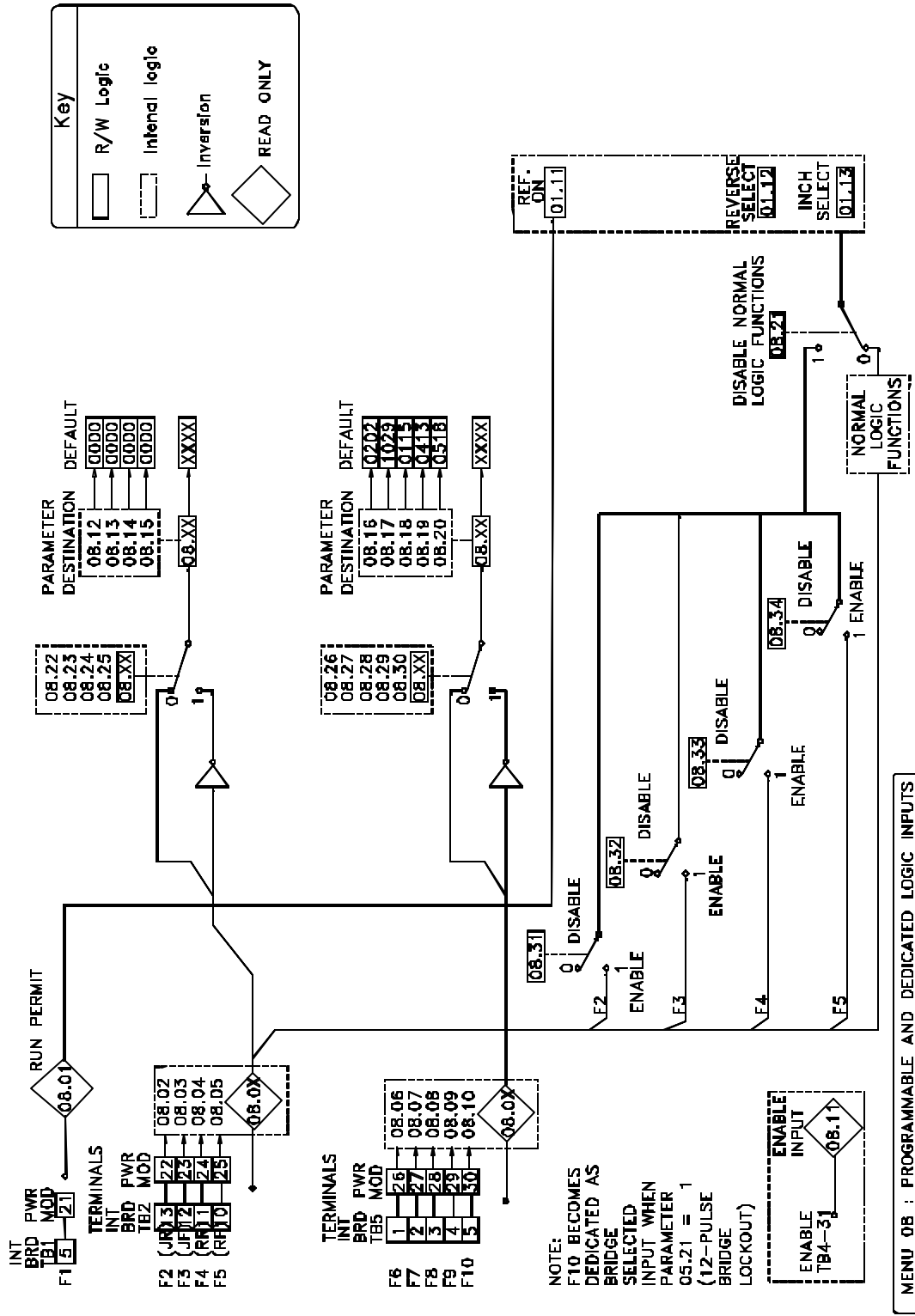

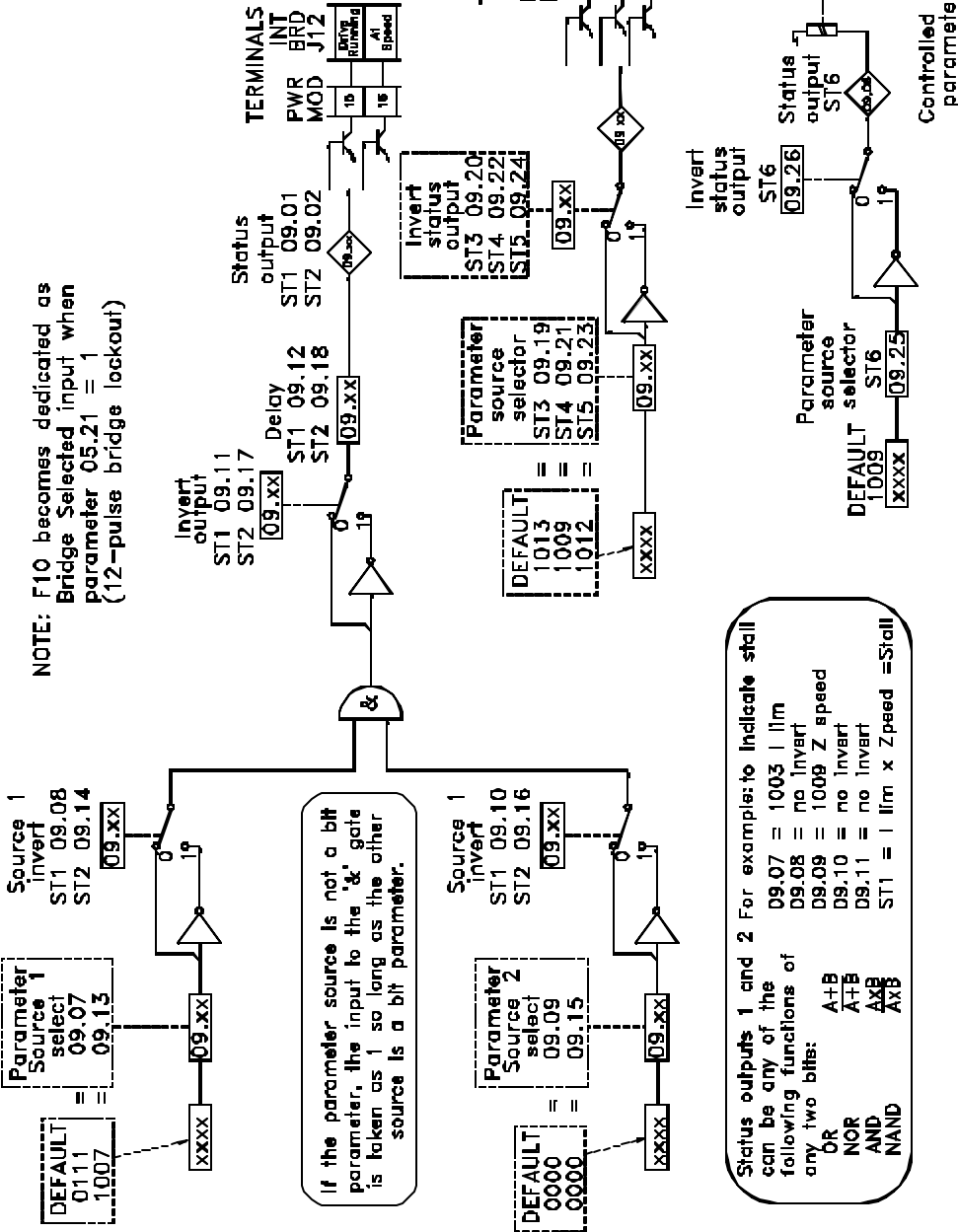
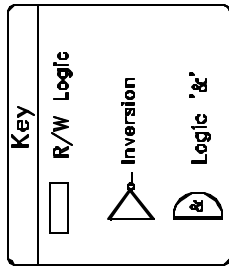

MENU 09 : STATUS OUTPUT

66 Flowcharts

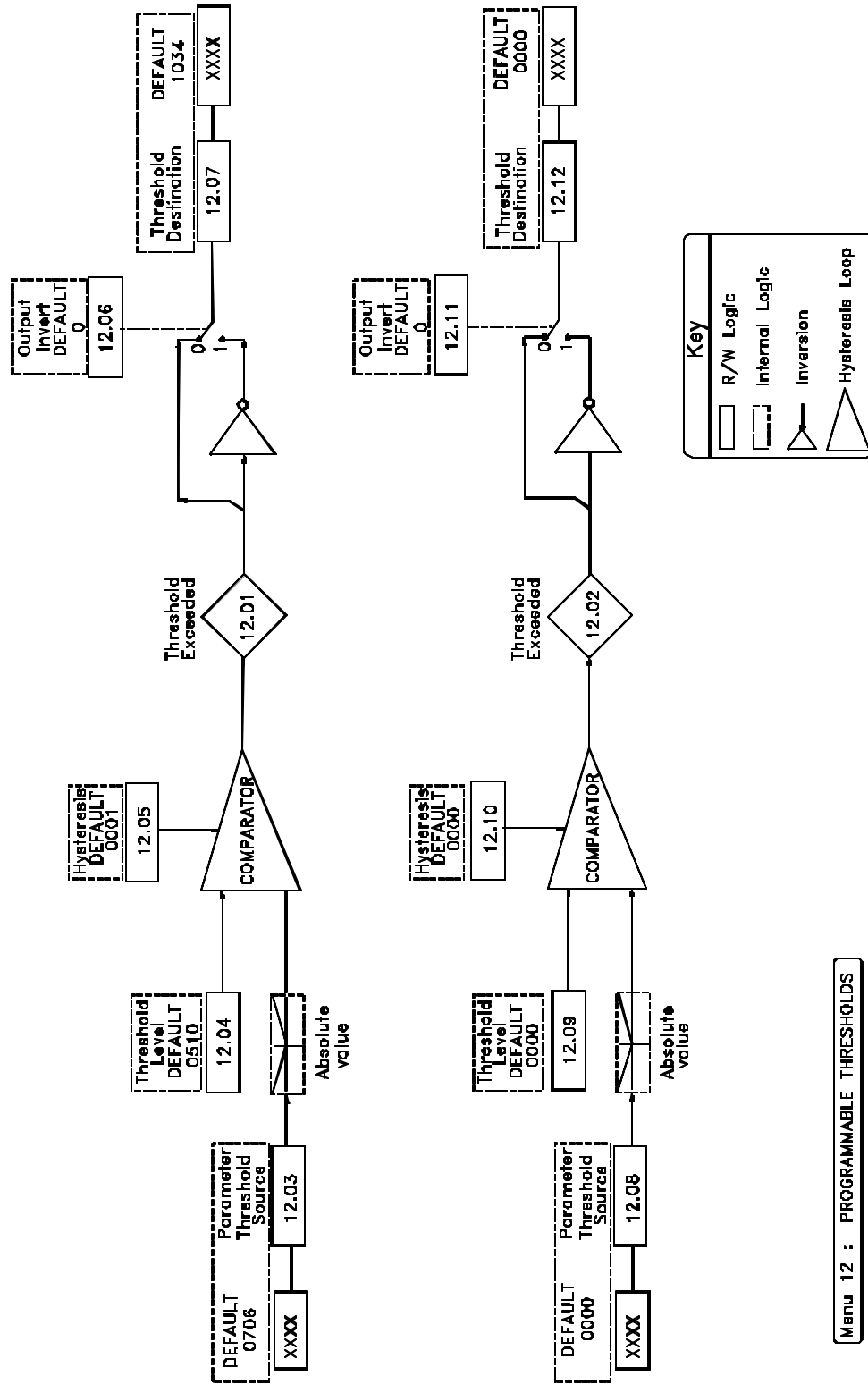

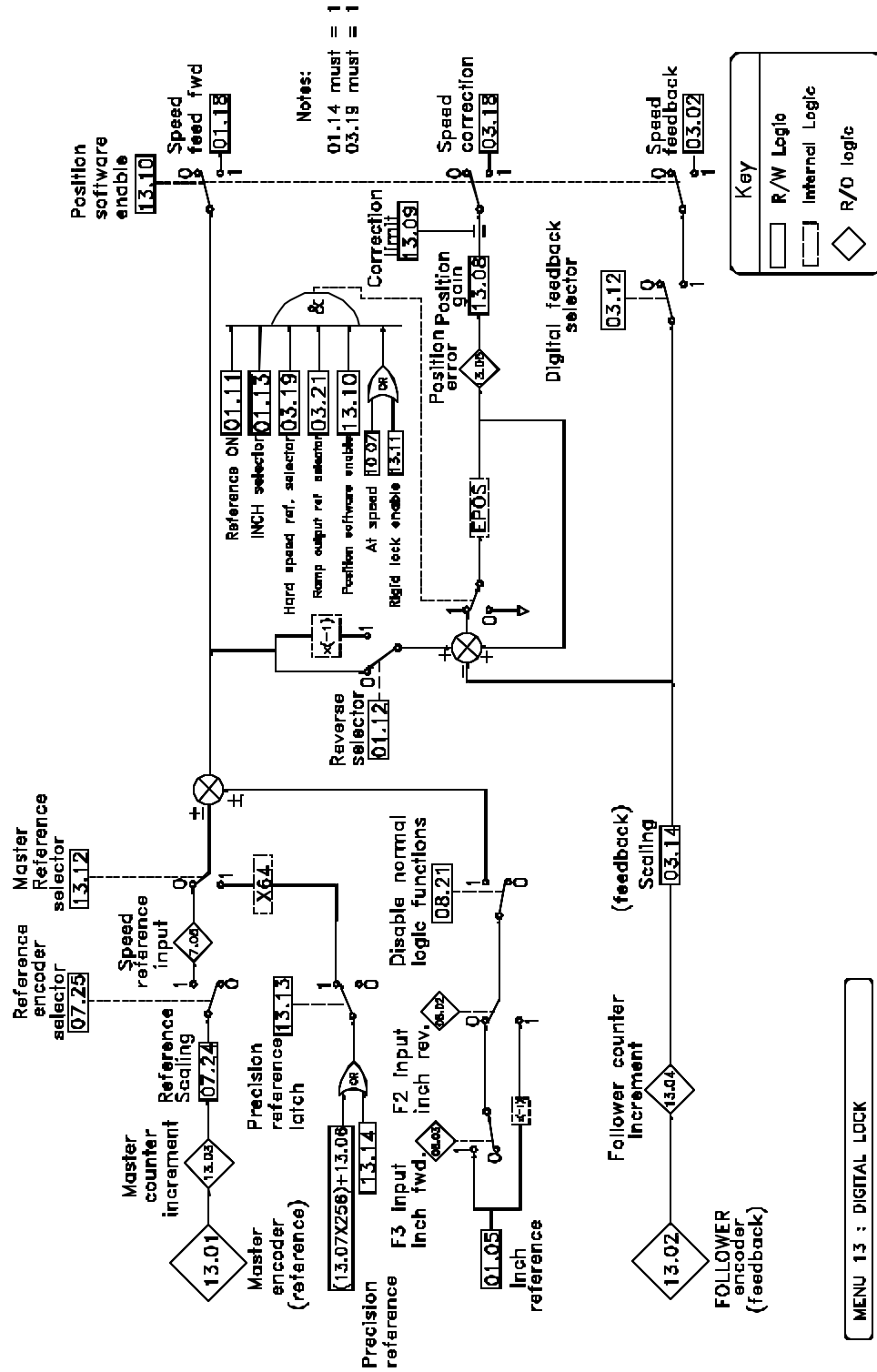

68 Parameter Descriptions

Parameter Descriptions (with Default Values)

Menu	Description
00	Custom User-Defined Menu (Set by Menu 11 Parameters)
01	Speed Reference Selection & Limits
02	Ramp Selection (Accel/Decel)
03	Feedback Selection and Speed Loop
04	Current-Selection & Limits
05	Current Loop
06	Field Control
07	Analog Inputs and Outputs
08	Logic Inputs
09	Status Outputs
10	Status Logic & Fault Information
11	Miscellaneous (0 Menu Customizing and Serial Communications)
12	Programmable Thresholds (Level Detection)
13	Digital Lock (Shaft-Lock)
14	Special Applications Software (MD29 Set-Up and Communications)
15	Special Applications Menu 1 (MD29 Special Software parameters, if applicable)
16	Special Applications Menu 2 (MD29 Special Software parameters, if applicable)

MENU 00 - Custom User-Defined (Set by Menu 11)**Menu 00 - user programmable parameters**

Menu 00 is a menu of parameters that are programmed to look at other drive parameters from any menu. This allows operators and Maintenance personnel to look at any 10 parameters in the Mentor drive all located in one menu. By programming needed parameters to monitor or adjustment in this menu operators primarily need not know all drive menus to do there job. The procedures for setting the parameters viewed by 0.01 to 0.06 are controlled by parameters 11.01 through 11.06 consult menu 11 descriptions. Descriptions of the **defaulted** parameters looked at are as follows:

(RO) = Read only parameter, these parameters can not be changed only viewed.

(RW) = Read write parameter, these parameters can be changed and viewed.

0.00 (RW) Security parameter

This parameter is used to enter a security number to allow access for changing and viewing all parameters in the drive. A value of 200 allows access to all parameters in the Mentor Drive. Normal setting is 0000.

0.01 (RO) Pre-Ramp Speed Demand Input

Looks at the value in parameter 7.05 and represents the speed pot setting or analog input setting. This parameter can be used to look at the speed setting from the speed input before or after the drive is started and is always active. Values = 0 to ± 1000 (0 to $\pm 100.0\%$)

0.02 (RW) Max. Speed Forward

Writes a value to parameter 1.06 and represents the maximum forward speed limit in percent. Values range from 0 to 1000 and represent 0 to 100.0% speed. Normal setting is 1000.

0.03 (RW) Minimum Speed Forward

Writes a value to parameter 01.07 to set min speed in the forward direction. Values range from 0 to 1000 and represent 0 to 100.0% speed. Normal setting is 0000.

0.04 (RW) Acceleration Ramp Time Forward

Writes a value to parameter 02.04 to set the acceleration time taken for the drive to accelerate the motor from zero speed to full speed. This is usually from 0 to 1750 rpm base speed of a standard motor. Values range from 0 to 1999 which represents 0 to 199.9 seconds. Normal setting is 0050.

0.05 (RW) Deceleration Ramp Time Forward

Writes a value to parameter 02.05 to set the deceleration time taken for the drive to decelerate the motor from full speed to rest. This is usually from 1750 rpm base speed of a standard motor to rest. Values range from 0 to 1999 which represent s 0 to 199.9 seconds. Normal setting is 0050.

0.06 (RW) Current Limit Bridge 1

Writes a value to parameter 4.05 where 0 to 1000 in Mentor units is equal to 0 to 150 % of the drive's current rating for Bridge 1. Normal setting is 1000.

70 Parameter Descriptions

0.07 (RW) Current Limit Bridge 2

Writes a value to parameter 4.06 where 0 to 1000 in Mentor units is equal to 0 to 150% of the drive's current rating for Bridge 2. Normal setting is 0 for non-regen drives and 1000 for regen drives.

0.08 (RW) Jog Speed

Writes a value to parameter 1.05 where 0 to 1000 in Mentor units is equal to 0 to 100% jog speed.

0.09 (RW) IR Compensation

Writes a value to 3.17 (IR Compensation) in the case where the drive is in armature feedback and loading the motor results in droop or boost in motor speed (dependant on motor characteristics). The range is 0 to 255. The default setting is 000.

0.10 (RW) Speed Loop P Gain

Writes a value to 3.09 (Speed Loop Proportional Gain). Increasing the value causes the drive to be more responsive to speed changes. Setting the value too high will cause the drive to be unstable. The range is 0 to 255. The default is 080.

MENU 01 - Speed Reference

There are four speed references: 1.17, 1.18, 1.19 and 1.20. As default, Parameter 1.17 is programmed to represent the speed pot or analog line speed reference. The other three references are programmable presets or controlled by analog inputs. Two selectors, 01.14 and 01.15, control the selection of reference and are set digitally via keypad or by using external contacts or switches to toggle between each preset (Refer to Menu 08 for further details).

The Pre-Ramp Reference (1.03) will always be clamped to zero if the following is true.

1. Parameter 8.01 is set to zero. Parameter 8.01 is set to a value of 1 if TB3-21 of the Power Module is connected to Drive Common. This indicates that the STOP circuit is satisfied.
2. Reference "ON" (Parameter 1.11) is set to zero. Parameter 1.11 is set to 1 if :
 - a) Parameter 8.01 is set to 1.
 - b) Parameter 1.16 (Zero Reference Interlock) = 0

The user can inhibit the drive from starting until the operator sets the speed pot or line speed reference to 0. This may be desired for safety. Parameter 1.16 (Zero Reference Interlock), if set to 1, will not allow 1.11 to be set to a 1 unless Parameter 1.01 is in the window of 0.1% around 0 speed.

01.01 RO Pre-offset speed reference

Range ±1000

A Read-Only parameter that can be used to verify which of the four preset references is active. For example, if Parameter 1.17 is the active preset then Parameter 1.01 represents the value in Parameter 1.17.

01.02 RO Post-offset speed reference

Range ±1000

Displays the value of the speed reference after the offset, Parameter 1.04, has been added.

01.03 RO Pre-ramp reference

Range ±1000

The final speed reference before any accel or decel rates are applied (refer to Menu 02 for details).

01.04 R/W Offset

Range ±1000 Default +000

Parameter 1.04 (Offset) adds to the pre-offset speed reference (1.01). It is a practical speed trim input (i.e. dancer trim). In this example, the dancer pot would be directed to 1.04 via analog input (See Menu 07).

72 Parameter Descriptions

01.05 R/W Inch (Jog Speed Preset) reference

Range ±1000 Default +050

Parameter 1.05 is the Jog Speed Preset. The Jog Speed Preset is activated by Parameter 1.13. The Inch Selector (Parameter 1.13) is selected by terminals TB3-22 and TB3-23 (Inch Reverse, Inch Forward). The value of 1.05 must be less than the maximum set by 01.06 and 01.09.

01.06 R/W Max. Speed Forward

Range 0 to +1000 Default +1000

Sets the upper limit of the speed reference in the forward direction.

01.07 R/W Min. Speed Forward

Range 0 to +1000 Default +0000

Sets the lower limit of the speed reference in the forward direction. This setting is disabled if the bipolar selector 01.10 = 1 (assuming a regenerative drive). This is intended to prevent oscillation between the forward and reverse bridges when the input speed reference is zero.

01.08 R/W Min. Speed Reverse

Range -1000 to 0 Default 0000

Sets the lower limit of speed in the reverse direction. This setting is disabled if the bipolar selector 01.10 = 1 (assuming a regenerative drive). This is intended to prevent oscillation between the forward and reverse bridges when the input speed reference is zero.

01.09 R/W Max. Speed Reverse

Range -1000 to 0 Default -1000

Sets the upper limit of speed in the reverse direction.

01.10 R/W Bipolar selector

Default - 4Q 1 bipolar mode

Default - 1Q 0 unipolar mode

If Parameter 1.10 is set to 1, any negative reference appearing in Parameter 1.02 is blocked (or clamped to zero). If Parameter 1.10 is set to 0 then both positive and negative reference values in Parameter 1.02 are passed as legitimate reference values.

01.11 R/W Reference 'ON'

Default 0 no speed reference

Parameter 1.11 controls the enable and disable of the speed reference. If Parameter 1.11 is set to 0 then the Pre-Ramp Reference (Parameter 1.03) is clamped to 0 (disabled).

When Parameter 1.11 is set to a 1, then the speed reference is enabled. Parameter 1.11 is set to 1 if :

- ? Parameter 8.01 is set to 1.
- ? Parameter 1.16 (Zero Reference Interlock) = 0 or Parameter 1.16 = 1 and the Pre-offset Speed Reference (Parameter 1.01) is in the 0.1% window around zero (i.e. The Speed Pot is set to 0).

01.12 R/W Reverse selector

Default 0 reverse not selected

Reverse select inverts the polarity of the speed reference signal. On a non-regenerative drive the speed reference is clamped at 0 if selected. On a regenerative drive the speed reference is negative if selected and the drive will reverse direction. If the Inch Rev or Run Rev input is made, then parameter 1.12 changes from a 0 to a 1.

01.13 R/W Inch selector

Default 0 Inch not selected

If Parameter 1.13 = 1, then the speed reference is set to the Jog Preset Speed (Parameter 1.05). Parameter 1.13 is set by the Inch Fwd or Inch Rev inputs.

01.14 R/W Reference selector 1

Default 0

The two reference selectors 01.14 and 01.15 are used in tandem to select one of the four speed references (1.17 to 1.20).

01.15 R/W Reference selector 2

Default 0

The two reference selectors 01.14 and 01.15 are used in tandem to select one of the four speed references (1.17 to 1.20).

74 Parameter Descriptions

01.16 R/W Zero reference interlock

default 0 inhibit not applied

If Parameter 1.16 is set to 1, the speed reference is clamped to 0 until the pre-offset speed reference is within a window around 0.

16 < 01.01 <= 16 (values in 0.1% of full speed)

The Zero Reference Interlock feature can be used as safety or in cases where it is desired that the operator set the speed pot to zero before being allowed to start.

01.17 01.18 01.19 01.20 R/W References 1 to 4

Defaults 0

As a default, the speed pot or analog line speed input (TB1-3 appears in Parameter 01.17 (Reference 1) via the programmable destination parameter 7.15. Preset parameters 1.18, 1.19, and 1.20 can be set digitally or set by speed pot via an analog input. Preset selection is achieved by Reference Selectors 1 and 2 (Parameter 1.14 and 1.15).

MENU 02 - Ramp Selection

The highlight of the Ramp Selection menu is the selectability of forward and reverse Accel/Decel times. This feature provides a large number of possible speed profiles. Parameter 2.18 selects Group 1 or 2 and 2.14, 2.15, 2.16, and 2.17 select specific ramps. Parameters 2.04 through 2.10 set the times for the ramps selected. Ramp Selection is shown in the table below.

Ramp Selected	Time Parameter	Select Parameter	Group Select (2.18)
Fwd Accel 1	2.04	2.14=0	0
Fwd Accel 2	2.08	2.14=1	1
Fwd Decel 1	2.05	2.15=0	0
Fwd Decel 2	2.09	2.15=1	1
Rev Accel 1	2.07	2.17=0	0
Rev Accel 2	2.11	2.17=1	1
Rev Decel 1	2.06	2.16=0	0
Rev Decel 2	2.10	2.16=1	1

A dedicated rate and selection is available for inch (Jog) where parameter 2.12 sets the Jog Ramp Rate and 2.13 sets the Enable Inch Ramp. If 2.13 is set to 1 then any time a forward or reverse inch (Jog) input is made, the Jog Ramp is enabled.

For Master/Follower or Auto/Manual applications, the Ramp Enable (Parameter 2.02) can be used to Bypass or Enable the ramp. Typically, in Manual Mode, it is desirable that the Follower use the internal ramp in the drive. In Auto Mode, the Follower's internal ramp is bypassed and the accel/decel is provided externally from the Master's line speed signal.

02.01 RO Post-ramp Reference

Range ±1000 rpm

Monitors the value of the pre-ramp reference (1.03) after it has bypassed or been modified by the ramp selected.

02.02 R/W Ramp Enable

Default 1 enabled

If set to 0, the post-ramp speed reference (2.01) equals the pre-ramp speed reference (1.03) and all accel/decel ramps are bypassed.

02.03 R/W Ramp Hold

Default 0

The ramp output (Parameter 2.01) is frozen at its present value when 2.03 is set to a 1. By using a programmable input to toggle this parameter, the speed of the drive may be controlled from 'increase' and 'decrease' pushbuttons. This provides a simulation of a motorized speed pot (MOP).

02.04 02.05 02.06 02.07 R/W

Group 1 Fwd. Accel & Decel. Rev. Decel & Accel

Range 0 to 1999 tenths of seconds

Default +050 = 5s

Sets the accel/decel times based on accelerating from a stopped condition to maximum speed (typically the base speed of the motor) or to decelerate from maximum speed to a stop. Parameter 1.03 equals 1000 at maximum speed demand.

02.08 02.09 02.10 02.11 R/W

Group 2 Fwd. Accel & Decel. Rev. Decel & Accel

Range 0 to 1999 tenths of seconds

Default +100 = 10s

02.12 R/W Inch Ramp Rate

Range 0 to 1999 tenths of seconds

Default +100 = 10s

Defines the Jog Speed Reference accel/decel time.

02.13 R/W Enable Inch Ramp

Default 0.Disable

A dedicated rate and selection is available for inch (Jog) where parameter 2.12 sets the Jog Ramp Rate and 2.13 sets the Enable Inch Ramp. If 2.13 is set to 1 then any time a forward or reverse inch (Jog) input is made, the Jog Ramp is enabled.

76 Parameter Descriptions

02.14 02.15 02.16 02.17 R/W

Fwd. Accel & Decel. Rev. Decel & Accel - Select from Group 1 or 2

Default 0 Ramp 1

Used in tandem with the Group Select (2.18), various accel/decel times can be selected. (See Ramp Selection Table in the Menu 2 Introduction.)

02.18 R/W Common Ramp Select

Default 0 Group 1

Used in tandem with the individual ramp selects (2.14 through 2.17) to select various accel/decel times. 2.18 = 0 selects Group 1; 2.18 = 1 selects Group 2.

02.19 R/W Ramp Scaling

Default 0 Disable

When parameter 02.19 is set to 1 the acceleration and deceleration ramp time is multiplied by 10.

MENU 03 - Feedback Selection and Speed Loop

The Final Speed Demand (Parameter 3.01) provides the actual reference to the velocity loop of the drive. Parameter 3.02 (Speed Feedback) is derived from one of three possible sources, encoder, tach-generator or armature voltage. Parameters 3.12 and 3.13 selects which mode of feedback is used. (Refer to the Armature Voltage, Tach, and Encoder Feedback Set-Up section of this manual for further details. Subtracting the Speed Feedback (Parameter 3.02) from the Final Speed Demand (Parameter 3.01) yields the Speed Error (Parameter 3.06). Ideally, the speed error should be 0. The Speed Error provides the input to the Velocity PID loop. The output of the PID loop (Parameter 3.07) provides the reference for the torque (current) loop of the drive.

03.01 RO Final Speed Demand

Range ±1000

Serves as the actual speed reference to the velocity loop of the drive.

03.02 RO Speed Feedback

Range ±1000

Monitors the value of the speed feedback, derived from one of the following three sources - encoder, tach-generator, or armature voltage. The selection is controlled by 03.12 and 03.13. Armature Voltage Feedback is set by parameter 3.15 (maximum armature voltage). When an encoder is used, the encoder feedback scaling is set by 03.14. If a tach-generator is used, a potentiometer (RV1) and SW1 dipswitch on the MDA-2(B) board sets the scaling of the tach feedback signal. The speed feedback (3.02) is subtracted from the Final Speed Demand (3.01) to yield an error signal.

03.03 RO Speed Feedback

Range ±1999rpm

Parameter 3.03 is a read-only parameter that simulates a digital speed meter (in rpm) for viewing purposes only. For a reliable reading it requires that parameter 3.16 (Max. Speed Scaling) be set to the maximum speed expected (typically the base speed of the motor).

03.04 RO Armature Voltage

Range ±1000 (direct reading in volts)

Parameter 3.04 can be used to monitor the actual armature voltage (similar to using a DC voltmeter).

03.05 RO IR Compensation Output

Range ±1000

Parameter 3.05 shows the actual IR compensation term. The IR Comp Output is determined by the integral output of the Velocity PID loop multiplied by the IR Compensation set by Parameter 3.17.

03.06 RO Speed Error

Range ±1000

The result of subtracting the speed feedback (3.02) from the final speed demand (3.01) and passing the error signal through a digital filter (set by 3.25).

03.07 RO Speed Loop Output

Range ±1000

The output of the Velocity Loop which becomes the torque (current) reference to the current loop.

03.08 RO Speed Error Integral

Range ±1000

The integrated value of the speed error (Parameter 03.06), used as input to the IR compensation calculation when using armature voltage feedback (AVF).

03.09 R/W Speed Loop Proportional Gain

Range 0 to 255 Default 080

The Speed Loop Proportional Gain sets the proportional amount of correction in the Velocity PID loop.

$$\text{Proportional Term} = \frac{03.09}{8}$$

Increasing this value increases both the system damping and the transient speed response. If the Proportional Gain is set too high for a given load, the system will become unstable. The optimum setting is the highest value possible before instability starts to occur. Optimum speed loop performance can be achieved by tuning all three gains in the PID algorithm.

78 Parameter Descriptions

03.10 R/W Speed Loop Integral Gain

Range 0 to 255

default 040

Parameter 3.10 (Speed Loop Integral Gain) sets the amount of integration(reset) correction.

$$\text{Factor} = \frac{6f \times 03.10}{256}$$

where f = supply frequency

This term ensures zero speed error during steady state load conditions. Increasing Parameter 3.10 increases the rate of recovery after a disturbance. If the term is made too high, oscillations may occur. The optimum setting is the highest value possible before oscillation starts to occur. Optimum speed loop performance is achieved by tuning all three gains in the PID algorithm.

03.11 R/W R/W Speed Loop Derivative Gain

Range 0 to 255 Default 0

Parameter 3.11 (Speed Loop Derivative Gain) sets the amount of Derivative (Rate) correction in the Velocity PID loop. The Derivative Gain is multiplied by three possible Source signals:

- 1) Final Speed Demand (Parameter 3.01)
- 2) Speed Feedback (Parameter 3.02)
- 3) Speed Error (Parameter 3.06)

Signal selection is made via Parameter 3.24 (Differential Term Source). Derivative compensation (correction) is a function of the rate of change of the Source signal. If the Source is the Speed Error (3.06) and the speed error increases, the Derivative portion of the PID output (compensation) is negative (in the opposite direction of the error term). This has a damping effect and is typically used for high inertial loads (i.e. large centrifugal loads, fans, pumps, wind/unwind, etc.).

If the input is the Final Speed Demand (3.01), the Derivative portion of the PID output is positive when the final speed demand (3.01) is increasing. This is called a 'velocity feed forward'.

If the input is the Speed Feedback (3.02), the Derivative portion of the PID output is negative if the speed feedback (3.02) is increasing. Similar to using the Speed Error as the Source, using the Speed Feedback (3.02) has a damping effect. However, using the Speed Feedback as the Source forces the Derivative Correction Term to be dependent on the changing value of the speed feedback only, not the Final Speed Demand (3.01).

03.12 R/W Digital Feedback Selector

Default 0 analog feedback selected

Setting 3.12 to 1 selects Encoder Feedback. Set to 0 to select analog feedback. If 3.12 is set to 0, the feedback selection is governed by Parameter 3.13. Setting parameter 03.13 = 0 selects Tach Feedback; Setting parameter 03.13 = 1 selects Armature Voltage Feedback.

03.13 R/W Armature voltage/external analog feedback selector

Default 1 analog feedback selected

If 3.12 is set to 0, the feedback selection is governed by Parameter 3.13. Setting parameter 03.13 = 0 selects Tach Feedback; Setting parameter 03.13 = 1 selects Armature Voltage Feedback.

03.14 R/W Encoder Feedback Scaling

Range 0 to 1999 Default +419

The Encoder Feedback Scaling is based on the maximum speed of the motor expected (typically motor nameplate base speed) and the number of lines-per-revolution (PPR) of the encoder. To calculate the scale factor:

$$3.14 = \text{Scale factor} = \frac{750 \times 10^6}{N \times n}$$

Where **N** = number of lines-per-revolution (PPR) on encoder and **n** = max speed of motor in rpm.

Default value of 419 is based on a 1024 PPR encoder and a maximum speed of 1750 rpm. See the encoder feedback set-up section of this manual for more details.

03.15 R/W Maximum Armature Volts

Range 0 to 1000 Default +600 (Shipped as 500 VDC or 240 VDC)

Sets the maximum armature voltage scaling. When armature voltage feedback is selected (3.12 = 0 and 3.13 = 1), parameter 3.15 sets the linearity of speed reference to armature voltage (0-1000 Final Speed Demand (3.01) = 0 to Max. Armature Voltage (3.15). An automatic scale factor of 1.2 is provided to clamp the armature voltage feedback to 20% above maximum to allow for overshoot.

If the speed feedback is provided via an encoder or tach-generator, the armature voltage is continuously monitored, and a clamp is applied when the voltage exceeds 1.2 times the level set in 3.15.

03.16 R/W Maximum Speed

Range 0 to 1999 Default +1750

Parameter 3.16 provides the scaling required so that the digital meter (Parameter 3.03) reads actual motor speed in rpm. The scaling in 3.16 should be set to the maximum speed in rpm expected (typically motor nameplate base speed). If the maximum speed is >1999rpm, the scaling in Parameter 3.16 should be the maximum speed expected divided by 10. In this case the speed displayed in 3.03 is the motor rpm divided by 10.

80 Parameter Descriptions

03.17 R/W IR Compensation

Range 0 to 255 Default 000

$$\text{Value of 03.05} = \frac{03.08 \times 03.17}{2048}$$

When armature voltage feedback is selected a speed deviation may occur from the no-load to loaded condition. This loss in speed is due to the voltage drop across the armature resistance when the armature current rises under load. The IR Compensation provides a boost to compensate for these losses and allow the no-load and loaded speeds to be matched. The boost is provided by subtracting from the Speed Feedback (Parameter 3.02) when the IR Droop Selector (3.20) is set to 0 so that less Speed Feedback is subtracted from the Final Speed Demand (Parameter 3.01) and thus resulting in more speed.

IR compensation is a positive feedback and may create instability if Parameter 3.17 is set too high. Beware of modern laminated-frame motors that may have a rising load vs. speed curve. These motors are not recommended to be used with armature voltage feedback and IR compensation. IR compensation is more suited to be used with compound-wound motors that exhibit a constant load vs. speed curve.

Note: IR compensation is based on the integral output of the Velocity's PID loop when the PID source is Speed Error.

03.18 R/W Hard Speed Reference

Range ±1000 Default 000

The Hard Speed Reference provides an addition to the Post Speed Reference(2.01) and appears as a contribution to the Final Speed Demand (Parameter 3.01) without passing through the accel/decel ramps. Most often it is used as a dancer input for line speed with dancer trim. Note: Unlike Parameter 1.04 (Offset), Parameter 3.18 does NOT pass through the accel/decel ramps.

03.19 R/W Hard Speed Reference Selector

Default 0

If 03.19 is set to 1, and ref 'ON' (01.11) = 1, the Hard Speed Reference (3.18) contributes to the Final Speed Demand (Parameter 3.01).

03.20 R/W IR Droop Selector

Default 0

If Armature Voltage Feedback is selected and 3.20 is set to 1, the speed feedback value in Parameter 3.02 will increase as load increases and thus slow the motor down with load.

An example of using IR Droop involves a mechanical blanking press fitted with a heavy flywheel. Applying IR droop prevents the drive from delivering a sudden increase of current at the moment of impact (sudden increase of torque demand). Ideally the drive should deliver constant energy to the flywheel during the entire

operating cycle rather than a burst of energy at the moment of impact.

03.21 R/W Ramp Output Selector

Default 1

When 03.21 = 1, the Post-Ramp Reference (2.01) contributes to the Final Speed Demand (3.01).

03.22 R/W Speed Offset Fine

Range 0 to 255 Default 128

Used as a fine Offset (+ Trim) and contributes to the Final Speed Demand (3.01).

03.23 R/W Zero Speed Threshold

Range 0 to 255 Default 16

The Zero Speed Threshold sets a window around zero speed from 0 to +/- 25.5% of maximum speed. 0 to 255 is equivalent to 0 to +/-25.5%. The Zero Speed Threshold affects when the Zero Speed LED light on the front of the drive is lit and when the Zero Speed Relay (MDA-2B) or Zero Speed Status Output changes state. Sometimes when the Zero Speed indication is provided to a PLC it may be necessary to increase the window around 0 to provide time for the PLC input status to change (latch). Refer also to the Zero Speed Status Parameter (10.09), a read only that indicates whether the drive is at zero speed or not (10.09 = 0 indicates the drive is NOT at zero speed ; 10.09 = 1 indicates the drive IS at zero speed).

03.24 R/W Derivative Term Source

Range 1, 2 or 3 Default 1

The derivative term of the PID in the speed loop may use one of three sources:

- 1 = Speed error 03.06 - Damping based on speed demand and feedback
- 2 = Speed reference 03.01 - Velocity feed-forward
- 3 = Speed feedback 03.02 - Damping on feedback only ('feedback forcing').

See also Parameter 3.11 (Speed Loop Derivative Gain).

03.25 R/W Speed Error Filter

Range 0 to 255 Default 128

$$\text{Filter time-constant} = \frac{256}{6 f \times 03.25}$$

where f = supply frequency

82 Parameter Descriptions

A low-pass filter to reduce the effect on the speed error signal (03,04) of interference - from a noisy tach-generator. Example: As 3.25 ? the more the signal is filtered (dampened).

03.26 RO Tach-generator Input

Range ±1000

Monitors the tach input measurement. The tach potentiometer is used to scale the feedback signal such that at full motor speed, 03.26 = 1000. Units displayed = 0.1% of full speed per increment.

03.27 R/W Speed Feedback Range

Range 0

03.27 = 0 03.16 displays RPM

03.27 = 1 03.16 displays (RPM / 10)

03.28 R/W Speed Loop Proportional Gain Multiplier

Range 0

If parameter 3.28 is set to 1, proportional gain is increased by a factor of 4.

03.29 R/W Reduce Speed Loop Gains

Range 0

If parameter 3.29 is set to 1, the P and I gains (parameters 3.09 and 3.10) are reduced by a factor of 8 :

$$P \text{ Gain} = 3.09 / 64$$

$$I \text{ Gain} = 3.10 \times 6 \times f / 2048$$

This is useful in applications with low inertias or applications where the inertia of the load varies. If parameter 3.28 is set to 1 then parameter 3.29 has no effects on operation.

MENU 04 - Current Selection and Limits

One of the primary functions of Menu 4 is to select the mode of control: 1) Speed Mode 2) Torque Mode 3) Torque Mode with Speed Over-ride 4) Coiler/Uncoiler Mode. Another primary function is to provide Current Limiting for motor protection. There are two reference inputs to the Current Loop: the Speed Loop Output (3.07) and Torque Reference (4.08).

<u>Mode Of Operation</u>	<u>4.12</u>	<u>4.13</u>	<u>Current Loop Reference</u>
Speed	0	0	Speed Loop Output (3.07)
Torque	1	0	Torque Reference (4.08)
Torque With Speed Over-ride	0	1	Torque Reference (4.08) Under Load. If Unloaded, Speed Clamp is provided based on Final Speed Demand (3.01).
Coiler/Uncoiler	1	1	Intended for the steel industry. Consult factory.

The current limits for Bridges 1 and 2 are provided as clamps on the Final Current Demand (4.02) via I-Limit B(ridge)1, 4.05 and I-Limit B(ridge)2, 4.06.

In the case of a regenerative drive, Quadrants 1 through 4 can be enabled or disabled via Menu 04 (see parameters 4.14, 4.15, 4.16, and 4.17).

Another feature in Menu 04 is the ability to set a second current limit (04.07) which enables the I-Limit 2 (4.07) to be applied automatically after a given time delay set by the I-Limit Timer (4.19). A good example of this application involves a mixer. Typically the torque (load) requirement is high on start-up, but after some period becomes less. In this case a higher current limit facilitates the breakaway torque requirement and after that time the normal current limit become active and protects the motor in the steady-state condition.

04.01 RO Current Demand

Range ±1000

Displays the active Current Reference (either from the Speed Loop Output, 3.07 or from the Torque Reference, 4.08 depending on the mode of operation). **Note: If standstill is enable + active in torque mode then 4.01 is clamped to zero. Parameter 5.19 then needs to disable.**

04.02 RO Final Current Demand

Range ±1000

Displays the Final Current Demand, which serves as the Final Current Reference (feedforward) to the current loop (see MENU 05) after limits have been applied.

04.03 RO Over-riding Current Limit

Range ±1000

Displays the value of the current limit that will over-ride the Bridge 1 and 2 (4.05 and 4.06) Current Limits if the current taper calculation or I-limit 2 is selected.

84 Parameter Descriptions

04.04 R/W I-limit 1 (taper start point)

Range 0 to 1000 Default +1000

Serves as the current limit for bridges 1 and 2 and sets the level (or point) at which the current tapering begins (Refer to 04.20 and 04.21).

Note: I-limit 1 can be used in an application where the motor HP rating is significantly less than the drive's rating (this could be used as an alternative to changing the burden resistors).

04.05 R/W I-Limit Bridge 1

Range 0 to 1000 Default +1000

Limits the amount of current demanded when bridge 1 is on. Any demand for current exceeding the current limit is ignored. The range of 0 – 1000 equals 0 – 150 % of Drive Nameplate Full Load Amps.

04.06 R/W I-Limit Bridge 2

Range 0 to 1000 Default +1000

Limits the amount of current demanded when bridge 2 is on. Any demand for current exceeding the current limit is ignored. The range of 0 – 1000 equals 0 – 150 % of Drive Nameplate Full Load Amps.

04.07 R/W I-Limit 2

Range 0 to 1000 Default +1000

Available as an additional current limit for Bridges 1 and 2. I-Limit 2 is applied as the Over-riding Current Limit (displayed in 4.03) if the Select I-Limit 2 (4.10) is enabled. A time delay can be provided (refer to 4.18 and 4.19).

04.08 R/W Torque Reference

Range ±1000 Default +000

Serves as the Current Demand (4.01) if the drive is in Pure Torque Mode or when the drive is under load in Torque Mode with Speed Over-ride. Application examples are load-stands or winders where the percent load or tension is set via torque pot.

04.09 R/W Current Offset

Range ±1000 Default +000

Provides a trim to the current demand (4.01).

04.10 R/W I-limit 2 Selector

Default 0

4.10 = 1 selects the I-limit 2. Can be set automatically after a time delay if parameters 4.18 (Enable Auto I-Limit Change) and 4.19 (I-Limit Timer) are used.

04.11 R/W Current Offset Selector

Default 0

Setting 4.11 = 1 selects the current offset.

04.12 R/W Mode bit 0 04.13 R/W Mode bit 1

Default 0 not selected

Set 04.12 & 04.13 = 1 to select. The drive's mode of operation is selected as follows:

04.12 = 0 and 04.13 = 0 Speed control (default)

04.12 = 1 and 04.13 = 0 Pure Torque control.

In Pure Torque control, the torque reference (4.08) provides the Current Demand (4.01). Note that in this mode parameter 3.01 (Final Speed Demand) is clamped to zero whether a speed reference is provided or not.

4.12 = 0 and 4.13 = 1 Torque control with Speed Over-ride.

In the motoring quadrants, Torque Control with Speed Over-ride provides drive operation where under loaded conditions, the drive is controlled via a torque (tension) pot as a current reference (4.08) to the current loop. However, in the case where the motor becomes unloaded, the drive switches to speed mode and the drive reference comes from 3.01 (Final Speed Demand). This is useful in an application where a wire or web break would normally cause a runaway condition (i.e. pure torque mode). In this way, when the motor becomes unloaded, the speed is limited by the line speed reference. Note: The drive should be adjusted to run at a slight overspeed when unloaded in order to ensure adequate current demand at all speeds. Also note that if the line speed reference and the torque reference are opposite in polarity, the current demand (4.01) will be clamped to zero.

In the two regenerative quadrants, the current demand set by torque reference 04.08 is disabled (clamped to zero) when motor speed (3.02) is less than the final speed demand (3.01).

A disadvantage of this mode is that it cannot provide torque for both acceleration and deceleration. Parameter 04.08 acts as a controllable current limit in this mode.

04.12 = 1 and 04.13 = 1 Coiler/Uncoiler (Rewind, Unwind) control mode.

This mode differs from Torque Mode with Speed Over-ride in that it allows torque to be applied in either sense, for acceleration or deceleration, while preventing uncontrolled increase in speed or reversal if the load becomes zero. When the torque demand (4.08) and the speed error (3.06) is opposite in polarity, this mode automatically selects a zero speed reference (3.01, Final Speed Demand is clamped to zero).

86 Parameter Descriptions

For a coiler (rewind), the offset 01.04 should be set just slightly positive so that 3.01 is greater than the line speed reference. If decelerating at full roll, the torque demand may be negative. At this point, the speed reference is automatically set to zero so that the speed error (3.06) becomes negative. Once the torque demand and speed error become negative, decelerating torque is applied.

For an uncoiler (unwind), the offset 1.04 should be set just slightly negative so tension can be maintained at zero speed. As the line speed reference increases, 3.01 becomes positive. The line speed input should be scaled so the final speed demand (3.01) is always greater than the speed feedback (3.02), thus maintaining a positive speed error (3.06). Since the speed error is positive, anytime the torque demand is negative, the final speed demand (3.01) will be clamped to zero. Under acceleration the torque demand becomes positive and the value of 03.01 becomes the speed demand and accelerating torque is allowed (provided that the uncoiler (unwind) speed is not greater than 03.01).

For coiler/uncoiler applications, line speed reference corresponds to reel speed at minimum diameter (core).

04.14 R/W Quadrant 1 enable

Default 1 enable

Quadrant 1 is defined as motoring in the forward direction where speed and torque both have positive values.

04.15 R/W Quadrant 2 enable

Default 1 enabled for 4Q drive

Default 0 disabled for 1Q drive

Quadrant 2 is defined as regenerating (braking) in the reverse direction where speed has a negative value and torque has a positive value.

04.16 R/W Quadrant 3 enable

Default 1 enabled for 4Q drive

Default 0 disabled for 1Q drive

Quadrant 3 is defined as motoring in the reverse direction where speed and torque both have negative values.

04.17 R/W Quadrant 4 enable

Default 1 enabled for 4Q drive

Default 0 disabled for 1Q drive

Quadrant 4 is defined as regenerating (braking) in the forward direction where speed has a positive value and torque has a negative value.

04.18 R/W Enable automatic I-limit 2 change

Default 0 disabled

If 4.18 is set to a 1 (enabled), the I-limit 2 selector (4.10) is automatically changed to 1 after a time interval set by the I-Limit Timer (4.19). When using this operation, the I-Limit 2 is automatically selected after the time-out. The timer is enabled or reset by starting or stopping the drive.

04.19 R/W I-limit timer

Range 0 to 255 Default 000

A time interval up to 255 seconds can be programmed. If 4.18 = 1, the I-limit 2 is automatically selected when the set time elapses after a RUN command. This feature is useful in applications such as mixing where the starting load is high but the load falls to a lower, constant value after the machine has run for some time (during steady state).

04.20 R/W Current Taper 1 threshold

Range 0 to 1000 Default +1000

Sets the level of speed where Parameter 4.24 will change to a 1 if the speed feedback (3.02) exceeds the level set by 4.20. The Current Taper 1 Threshold also serves as the starting point for taper 1 (if implemented). As the speed feedback increases, the armature current limit decreases at a rate (slope) defined by 04.22.

Note that Taper 1 occurs before Taper 2. If only one taper is required then Taper 1 must be used. If both taper functions are used then Taper 1 will occur first and then Taper 2 will follow.

04.21 R/W Current Taper 2 threshold

Range 0 to 1000 Default +1000

Sets the level of speed where Parameter 4.24 will change to a 1 if the speed feedback (3.02) exceeds the level set by 4.20. The Current Taper 2 Threshold also serves as the starting point for taper 2 (if implemented). As the speed feedback increases, the armature current limit decreases at a rate (slope) defined by 4.23.

04.22 R/W Current Taper 1 slope

Range 0 to 255 Default 000

Sets the rate of change of armature current limit versus speed feedback (in either direction of rotation). The change will occur when the speed feedback (3.02) exceeds the threshold set in 4.20.

88 Parameter Descriptions

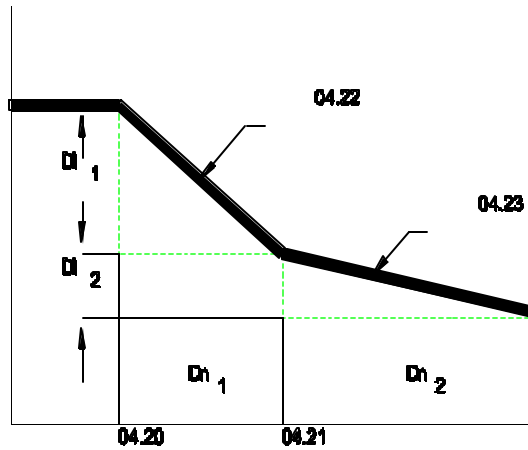

Calculation of current taper gradients 1 & 2. Refer to text, parameter 04.22 and 04.23.

04.23 R/W Current Taper 2 slope

Range 0 to 255 Default 000

Sets the rate of change of armature current limit versus speed feedback (in either direction of rotation). The Current Taper 2 occurs if the speed feedback exceeds the threshold set by 04.21.

04.24 RO Taper threshold 1 exceeded

Default 0

4.24 is set to 1 when the threshold set point (4.20) is exceeded.

04.25 RO Taper threshold 2 exceeded

Default 0

4.25 is set to 1 when the threshold set point 2 (4.21) is exceeded.

MENU 05 - Current Loop

The Current Loop provides the calculations to determine the final firing angle. In normal operation the current feedback (5.01) is subtracted from the final current demand (4.02) to provide an error signal. (Note that 4.02 is also subject to the slew rate limit (5.04) prior to the summing junction).

The current feedback is also used to provide motor protection via an alarm. If the current feedback (5.01) exceeds the selected overload threshold an alarm counter will begin to increment towards a trip at a rate based on the values for overload time. Parameters 5.07 and 5.08 are provided for overload timing based on heating and cooling. This accounts for the fact that the cooling time of a motor can be longer than its heating time.

05.01 RO Current Feedback

Range ±1000

Displays the Current Feedback in M4000 units based on 0 to 1000 = 0 to 150%.

Note: The current feedback signal is derived from internal current transformers. It is used for closed-loop control, indication of the armature current and to provide motor protection.

05.02 RO Current - Feedback Amps

Range ±1999

Using the scaling parameter provided(5.05), the current feedback in 5.01 can be calibrated to show current feedback in actual amps (viewed in 5.02, as read-only).

05.03 RO Firing Angle

Range 277 to 1023

The firing angle 05.03 = 1023 indicates fully 'phased forward' or a large conduction angle. A smaller number in 5.03 indicates a smaller amount of conduction (area under the AC sinusoid curve) and effectively a lower overall average DC level on the Armature Output.

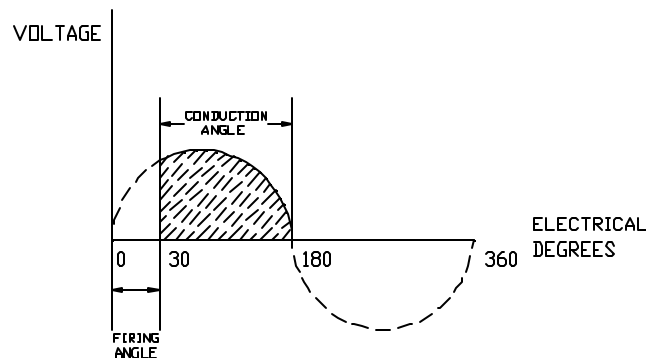

90 Parameter Descriptions

05.04 R/W Slew Rate Limit

Range 0 to 255 Default 40

This parameter limits the maximum rate of change of current demand. Older types of motors, especially of non-laminated construction, may have a tendency to flash over if the rate of change of current is too high for the inherent lag of the interpole windings.

Defined as -

$$S = I_{max} \times 6f \times \frac{05.04}{256}$$

Where, S = slew rate in amps s-1

f = frequency of the power supply in Hz

I_{max} = max. current (A)

A higher value in 5.04 results in more averaging (more dampened).

05.05 R/W Maximum Current Scaling

Range 0 to 1999 Default Drive current rating

Scales the current feedback (5.01) for viewing the actual current output of the drive in amps via the read-only parameter 5.02.

Note: This parameter does not have any effect on the motor protection (5.05 does **NOT** set the drive's current limit).

The setting for 05.05 is calculated as follows -

$$\begin{aligned} 05.05 &= \frac{I_{max}}{10} && \text{if } I_{max} > 1999A \\ 05.05 &= I_{max} && \text{if } 200A < I_{max} < 1999A \\ 05.05 &= I_{max} \times 10 && \text{if } I_{max} < 200A \end{aligned}$$

05.06 R/W Overload Threshold

Range 0 to 1000 Default +700

Sets the threshold of armature current feedback beyond which the overload alarm counter begins to increment (integrate) towards a trip. The default of 700 is equivalent to approximately 105% of the drive's FLA (Full Load Amperes).

05.07 R/W Overload Integrating Time (heating)

Range 0 to 255 Default 030

Integrating time for 05.06. Can be used in conjunction with 05.08 in cases that where the heating time is shorter than the cooling time (5.07 < 5.08).

Time t to trip is:

$$t = 05.07 \times \frac{1000 - 05.06}{05.01 - 05.06}$$

For example: Using the default values (5.07 = 030 and 5.06 = 700), if the current feedback = 800 in 5.01 then the time to trip (t) = 90 seconds. Using the same default values and assuming the worse case scenario, 5.01 = 1000 (in current limit), the time to trip (t) = 30 seconds. Refer also to Menu 10, parameter 10.18.

05.08 R/W Overload Integrating Time (cooling)

Range 0 to 255 Default 050

Integrating time for 05.06. For use in conjunction with 05.07, such that 05.07 < 05.08.

Time t to trip is:

$$t = 05.07 \times \frac{1000 - 05.06}{05.06 - 05.01}$$

Refer also to 5.07 (Overload Integrating Time (heating) and Menu 10 Parameter 10.18 (RO Sustained Overload).

05.09 R/W Enable Commissioning Autotune

Default 0 disabled

To autotune the current loop during commissioning -

- ? Disconnect the field of the motor if a fixed field is being used.
- ? **Observe approved safety procedures!**
- ? Enable autotune - set 05.09 = 1.
- ? Enable the drive by the input TB4-31.

When the autotune process is complete, the drive ready relay will open for 50ms after which the autotune parameter will be automatically set to disable (05.09 = 0). The purpose of this process is to allow the autotune sequence to be started when a 'run permit' is present but to return the drive to a safe condition

when the autotune is complete. It may be necessary to clamp the motor shaft if it tends to rotate during this procedure.

92 Parameter Descriptions

NOTES

- 1 The foregoing assumes that the drive ready relay is interlocked with any 'run permit' that is Present.
- 2 if the motor is being operated with field control (Menu 06), the field will be turned off automatically.

05.10 R/W Reduced Endstop

The endstop allows the armature voltage to rise, during regeneration, to 1.16 x supply voltage. On very 'soft' supplies the endstop may be too close to the crossover point. Setting 05.10 = 1 increases the safety margin but reduces the maximum regenerated armature voltage to 1.05 x supply voltage.

05.11 RO Actual overload

Range 0 to 1999

Monitors the value of the integrating current-time overload. When the value reaches the trip point determined by 05.06, 05.07 and 05.08, an overload trip occurs. The overload trip will operate when 05.11 reaches the value given by:

$$[05.11 = 1000] - 05.06 \times \frac{10}{16}$$

The rate at which 05.11 increases or decreases is controlled by the values of 05.07 and 05.08 respectively.

05.12 R/W Discontinuous I-gain

Range 0 to 255 Default 16

Set by the Commissioning Autotune parameter 05.09.

This parameter is set to correct any errors in the prediction of firing angle in the discontinuous current region. If 05.15 is set correctly, 05.12 has little effect, but if set too high, instability can occur.

$$\text{Gain applied} = 05.12 / 128$$

05.13 R/W Continuous P-gain

Range 0 to 255 Default 16

Set by the Commissioning Autotune parameter 05.09.

This parameter enables the current loop to follow very closely a step-change in current. If set too high, there will be an overshoot. If set too low, the current loop response will be too slow.

$$\text{Gain applied} = 05.13 / 256$$

05.14 R/W Continuous I-gain

Range 0 to 255 Default 16

Set by the Commissioning Autotune parameter 05.09. Its value will depend on the motor time-constant. Increasing the value of 05.14 will improve the response of the current loop but at the risk of instability.

$$\text{Gain applied} = 05.14 / 512$$

05.15 R/W Motor Time Constant

Range 0 to 255 Default 25

This parameter is used to scale the current demand such that the control loop correctly predicts the firing angle in the discontinuous current region. It is set automatically by the Commissioning Autotune parameter 05.09.

05.16 R/W Reserved

Range 0 to 255 Default 0

05.17 R/W Inhibit Firing

Default 0 enabled

If set to 1, disables thyristor firing (both bridges), and resets acceleration and deceleration ramps.

05.18 R/W Enable Standstill Logic

Default 1 enable

When enabled, causes the firing angle to be fully phased back when the drive has received a STOP command and when the speed falls below 0.8% of maximum speed. After a short time delay, the thyristors are inhibited also. This prevents 'creep' and is used in applications in which there is no requirement to maintain motor torque at standstill. Refer also 05.19.

05.19 R/W Standstill Mode

Default 0

05.19 = 0 - standstill logic is enabled after STOP command or zero reference.

05.19 = 1 - standstill logic enabled after STOP command only.

Setting 05.19 = 1 has the effect of not enabling the standstill logic when the stopping signal is given by the reference alone. This condition therefore allows creep speeds, shaft orientation, and other functions which take place close to zero speed, whilst preventing any 'creep' after a STOP command.

94 Parameter Descriptions

05.20 R/W Enable Direct Firing Angle Control

Default 0 disabled

When enabled, the firing angle 05.03 is controlled by the value of the post ramp reference 02.01. This mode is valuable for system diagnosis, particularly where instability is present, since it allows the drive to operate without the influence of either the speed loop or the current loop, thereby eliminating their effect upon the system.

NOTE: This facility must be used with caution. When the reference is 02.01, or current other than the instantaneous overcurrent trip. Also take care to reset 05.20 = 0 after completion of tests.

05.21 R/W Enable Bridge 2 Lockout

Default 0 disabled

Requires to be set only for parallel 12-pulse 4Q system installations comprising two drives which are to share load, to prevent one drive changing bridges while the other is still conducting.

05.22 R/W Disable Adaptive Control

Default 0 disabled

Setting 05.22 = 1 disables adaptive control

When adaptive control is enabled (default status) the current loop employs two different algorithms, one of which applies high gain in the discontinuous current region. This is unsuitable for some applications, such as non motor loads, for which adaptive control should be disabled.

05.23 R/W Enable Single-quadrant Series 12-pulse

Default 0 disabled

Enabling this function configures the drive to deliver normal and delayed firing pulses to a single 12-channel power board. Cannot be enabled if either of the Bridge 2 quadrants 04.16 and 04.17 are enabled.

In 6-pulse thyristor drives, the current drawn from each phase of the supply is not continuous. Out of each 180 degree of the AC supply cycle, full load current is drawn for 120 degree and none for the remaining 60 degree. This imposes a degree of harmonic distortion on the supply.

Twelve pulse thyristor drives draw current for the full 360 degree of the AC supply cycle, and the current waveform approximates very closely to a sine wave, with much-reduced distortion as a result.

A further advantage is the much smoother DC current output from 12-pulse drives, which is a benefit in many applications.

Two 12-channel Power Boards are driven by PCB MDA1 for 4Q series 12 pulse.

05.24 R/W Series 12-pulse operation

Default 0 disabled

This parameter should be set for operation in either single- or four-quadrant 12-pulse mode. Parameter 05.23 (see above) is read by the software only at power-on and during a cyclic reset (a reset when the drive is disabled). If either of the Bridge 2 quadrants is enabled when 05.23 is read, the outputs are not diverted within the ASIC and 05.23 is set to 0.

NOTE Series 12-pulse mode is phase-sensitive. The rotation on the stacks must be in the sequence L1, L2, L3 (10.11 = 1).

05.25 R/W Parallel 12-pulse operation

Default 0 disabled

This parameter instructs the drive to operate in parallel 12-pulse mode and should be set for operation in either single- or four-quadrant mode. For 4-quadrant operation, parameter 05.21 (see above) must be set to 1 and the F10 input of each drive must be connected to the ST5 output of the other. Also, the control OV terminals of both drives must be connected.

05.26 R/W Extra-safe Bridge Change

Default 0 disabled

When enabled (=1) parameter 05.26 applies an additional safety margin to the bridge changeover logic. This may be required for highly inductive loads, such as a motor field winding.

05.27 R/W Enable Continuous Auto-tune

Default 0 disabled

When enabled (=1) parameter 05.27 provides an additional auto-tune routine which continually monitors the current during continuous conduction and adjusts the current loop gains according to the amount of current ripple measured. The Commissioning Auto-tune test (parameter 5.09) should still be carried out since the Continuous Auto-tune does NOT adjust the Continuous Integral Gain (parameter 5.14). The Store Procedure for saving parameters should be executed when the current loop parameters are stabilized and the motor running smoothly (the Continuous Auto-tune doesn't save current loop parameters automatically). Note that the Current Ripple Auto-tune calculations are suspended when the voltage spill over loop becomes active (the gains are not increased as the field is weakened). The Current Ripple Autotune does not function when the drive is in serial 12 pulse mode as well (see parameter 5.24).

05.28 R/W Bridge Change Hysteresis

Default 0 disabled

When enabled (=1) parameter 05.28 reduces the bridge change over hysteresis from 1.6% to 0.2% of the drive's maximum current. Applications where the drive is used as a current amplifier only (where fine control of current is required), 1.6% hysteresis may be too large.

96 Parameter Descriptions

05.29 R/W Lower Current Ripple

Default 0 disabled

In non-motor applications, the current ripple at terminal 11 (in volts) must be a minimum of 0.6 V for the drive to operate correctly. If the voltage at terminal 11 is less than 0.6 V then set parameter 5.29 to 1 and increase the equivalent resistance of the burden resistors by a factor of 1.6. If the voltage measured at terminal 11 is greater than 0.65 V then the burden resistor values should not be changed.

MENU - 06 Field Control

The MENTOR II is equipped with field control as part of the on-board software. If a motor is being used with an uncontrolled ('fixed') field supply, this menu does not apply.

Provision is made for programming two selectable values of maximum field current. Further, the lower value of maximum field current can be controlled by a programmable timer so that, when the drive is not running, the field can be switched automatically to economy mode.

The resulting field current demand is summed algebraically with the field current feedback to produce a current error which is the input to the field current loop. The output of the field current loop is the firing angle, subject to the front endstop limit.

The field current can alternatively be controlled directly by either of the maximum field parameters 06.08 and 06.09 via a programmable input or by application software, and there is a facility for direct control of the firing angle, useful for diagnosis.

The principal inputs in spillover mode are, from the internal logic, the armature voltage; from external input, a set point for back-emf.

Field current demand is the output of the back-emf voltage loop, subject to programmed maximum and minimum field current values. The voltage loop compares the calculated back-emf value with a programmed set point which is used as factor in determining field current demand. The voltage loop output, and consequently the field current demand, is maximum when the calculated back-emf is less than the setpoint value. This occurs when the calculated value exceeds the set point value.

Alternatively, the user may wish not to use the voltage loop, but to enter a current demand directly. The user can set two maximum field current parameter values. In this mode, the value of the back-emf set point should be set to maximum, such that the voltage loop always demands maximum field current. The current demand is then the selected maximum field current parameter.

Parameter Descriptions 97

06.01 RO Back EMF

Range 0 to 1000

The calculated motor back emf based on armature voltage minus IR compensation value 2, 06.05. Feedback to the emf loop in spillover mode.

06.02 RO Field Current Demand

Range 0 to 1000

The current demand from the EMF loop, subject to the limits of 06.08, 06.09 and 06.10.

06.03 RO Field Current Feedback

Range 0 to 1000

Feedback to the field current loop. Based on a percentage of the current value of 06.11 (i.e. 1000 = 100%).

06.04 RO Firing Angle

Range 261 to 1000

Scaling - 06.04= 1000 corresponds to full advancement of the firing angle (no conduction). This means as the firing angle increases, the output decreases.

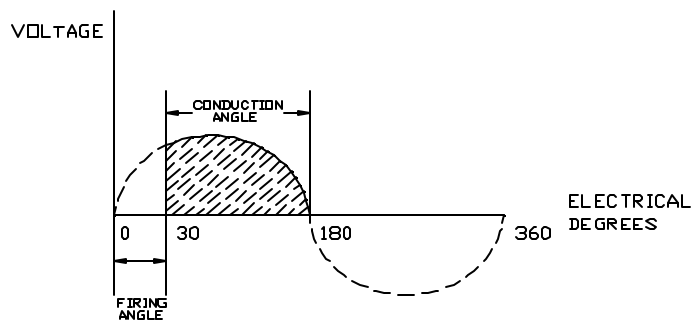

06.05 RO IR Compensation 2 Output

Range ±1000

The value resulting from the application of 06.06 to the speed error integral output 03.08.

06.06 R/W IR Compensation 2

Range 0 to 255 Default 000

A programmable factor used for calculation of the armature IR-drop as correction to measured armature voltage, to enable the back emf to be computed.

98 Parameter Descriptions

Scaling = 0 to 255 = 0 to 100% compensation

$$6.06 = \frac{3.08 \times 6.08}{2048}$$

6.07 R/W Back EMF Set Point

Range 0 to 1000 Default +400 (Shipped as 1000)

The programmable value of the armature back emf in volts, at which the field begins to weaken. Defined as the voltage at which base speed is reached. Note !!!! If the drive is factory defaulted, be sure to set this parameter to 1000 (unless the application calls for field weakening/extended speed range).

This parameter should NOT be less than 1000 if the drive is in armature voltage feedback !
Typically; 06.07 = .98 x (Motor Armature Voltage Nameplate)

06.08 R/W Maximum Field Current 1

Range 0 to 1000 Default +1000

Programmable value of the maximum current demand of the emf loop. If the field control is to be used in current mode, this parameter would become the current reference of the field control loop, and the back emf set point should normally be set to maximum to prevent spillover occurring; alternatively, if motor overvoltage protection by spillover is required, the back emf set point should be set to maximum armature voltage.

06.09 R/W Maximum Field Current 2

Range 0 to 1000 Default +500

For use as a field economy setting. Refer to 06.12, 06.14 and 06.15.

Typically; 06.09 = .667 x 06.08 (field economy mode only)

06.10 R/W Minimum Field Current

Range 0 to 1000 Default +500

The minimum value of current demand, to prevent excessive field weakening, for example with overhauling loads.

Typically,

$$06.10 = \frac{\text{Min. Field Current(amps)}}{\text{Max. Field current(amps)}} \times 6.08$$

06.11 R/W Field Current Feedback Scaling

Range 201 to 216 Default XXX (Factory set per drive's HP and Voltage Rating).
 Parameter 06.11 permits the user to apply a scaling factor to the current feedback. Output is the value 06.03. The max current rating is 2A (left position) or 8A (right position) according to the position of jumper link J1. See the MDA3 Set-Up in the main section of the manual.

J1 Position	06.11 setting	MDA3 amps. max	J1 position	06.11 setting	MDA3 Amps max.
2A	201	0.5	8A	209	4.5
2A	202	1.0	8A	210	5.0
2A	203	1.5	8A	211	5.5
2A	204	2.0	8A	212	6.0
8A	205	2.5	8A	213	6.5
8A	206	3.0	8A	214	7.0
8A	207	3.5	8A	215	7.5
8A	208	4.0	8A	216	8.0

NOTES MENTOR II can be used with an Issue 1 MDA3 card, maximum current 5A. Parameter 06.11 then has the range 101 to 110 and a field current range from 0.5A to 5A in steps of 0.5A.

Field control can alternatively be implemented by the FXM5 Field Control Module (optional) for a maximum field current of 20A.

06.12 R/W Field Economy Timeout

Range 0 to 255 Default 030
 Permits the drive to be configured to select maximum field 2 (a reduced setting) automatically after the drive has been disabled for a period (in seconds) defined by the value chosen for this parameter. Provided so that the windings do not overheat if the drive is stopped and the motor ventilation is switched off, or to maintain a reduced level of field current to prevent condensation when the motor is not in use.

06.13 R/W Enable Field Control

Default 0 disabled
 Turns the MDA-3 Field Regulator "ON" or "OFF".

100 Parameter Descriptions

06.14 R/W Maximum Field 2 Selector

Default 0 disabled

Set to 1 to engage maximum field 2. Controlled automatically by field economy timeout function if 06.15 is set to 1. Maximum field 2 is selected after a time delay (refer to 06.12) when a drive disable signal is given.

06.15 R/W Enable Field Economy Timeout

Default 0 disabled

When enabled (=1), parameter 06.14 is automatically controlled by the field economy timeout function when a drive enable signal is removed. When the timeout is disabled, parameter 06.14 becomes user R/W.

06.16 R/W Field Current Loop Gain Selector

Default 1

Affects the ratio of proportional to integral gains in the field current loop. Setting parameter 6.16 to 0 increases the integral gain which allows the field current loop to monitor the current demand more closely. Beware that the loop will become less stable (especially if the overall gains have been reduced using parameter 6.23 and/or 6.24). Generally parameter 6.16 should be set to 1 and should only be changed if fast changes in flux are required and the motor field time constant is low.

06.17 R/W Voltage Loop Integral Gain

Default 0 disabled

Set 06.17 = 1 to double the integral gain if less overshoot is desired.

06.18 R/W Enable Speed Gain Adjustment

Default 0 disabled

This parameter adjusts the speed loop gains (menu 03) to compensate for the weakening of the field flux in field control mode so that the torque response remains substantially constant throughout the whole speed

range. Defined as -
$$G = \frac{06.08}{06.02}$$

Where G = Speed loop gain adjustment factor

06.19 R/W Direct Firing Angle Control

Default 0 disabled

Enables 06.08 to control the firing angle directly, subject only to the front endstop. Permits operation without the voltage or the current loop, for the purpose of diagnosis.

NOTE In this mode there is **no protection** against excessive field voltage and current.

06.20 R/W Alternative IR Comp. 2 Selector

Default 0 = 03.08. 1 = 01.20

Determines the source of the IR Compensation 2. The source selection may be either the Speed Error Integral (03.08) or the Final Current Demand (04.02). Setting parameter 6.20 to 0 provides IR compensation in the field controller during Speed Mode Operation. In Pure Torque Mode, the speed loop does not operate (clamped at zero) and in Torque with Speed Over-ride Mode, the speed loop is normally saturated. In these applications, to overcome these issues, setting parameter 6.20 to 1 selects the IR Compensation source from a filtered level of the Final Current Demand (04.02).

06.21 R/W Firing Angle Front Endstop

Range 0 to 1000 Default +1000

Restricts the advance of the firing angle in cases where 180 degree advance would result in overvoltage being applied to the field windings.

06.22 R/W Full or Half Control Selector

Default 0 half control

Provides the option of full or half control. Available only with the FXM5 Field Controller. Please refer to FXM5 User's Guide for a complete explanation.

06.23 Field Gain Scaler 1

Default 0

Setting parameter 6.23 to 1 reduces the field current loop gains by a factor of 2. If both parameters 6.23 and 6.24 are set to 1 then the field current loop gains are reduced by a factor of 8.

06.24 Field Gain Scaler 2

Default 0

Setting parameter 6.24 to 1 reduces the field current loop gains by a factor of 4. If both parameters 6.23 and 6.24 are set to 1 then the field current loop gains are reduced by a factor of 8.

102 Parameter Descriptions

MENU 07 - Analog Inputs & Outputs

Menu 07 is arguably the most used, if not the most important, menu available in the Mentor II DC Drive. Menu 07 defines how the analog inputs are used in the drive and what information is delivered at the analog output terminals. This provides a tremendous amount of flexibility in the drive.

Menu 07 can be broken into 5 blocks (see the Menu 07 flowchart for further details) :

- 1) Primary Reference Input TB1-3 Power Module or TB4-7 User Interface Board
- 2) General Purpose Inputs (GP 1-4)
- 3) DAC Outputs 1-3 and 1 dedicated Armature Current Output
- 4) Tach Input
- 5) Thermal Switch Input

The Primary Reference Input block of the Menu 07 flowchart determines whether Speed Reference 1 (12-bit resolution) is a voltage input (typically 0-10 VDC), a current input (typically 4-20 mA but other ranges are available), or a digital pulse train (encoder) input. The General Purpose Inputs (GP1-4) block of the Menu 07 flowchart provides 4 user directable analog inputs (10-bit resolution). Scaling is available on each. Inversion is available on GP3 and GP4 for 4.5.0 or higher revision software (See parameter 11.15, Processor 1 Software Version for details). The Analog Outputs block of the Menu07 flowchart provides 1 dedicated output (TB2-11 Power Module or TB4-13 Interface Board) where 0 to 6.6 VDC output corresponds to 0 to 150 % FLA on the armature. The Analog Output block also provides 3 user defined analog outputs (DAC 1-3). Scaling is available on each. The Tach Input is programmed by dials on SW1 and scaled by RV1 potentiometer on the MDA-2(B) board.] The Thermal Switch Input (TB1-8 on the Power Module) can be enabled or disabled (see parameter 10.32) and its status can be viewed in parameter 10.21.

07.01 RO General Purpose Input 1

Range ± 1000

Displays the value of the analog signal applied to terminal TB1-4 on the Power Module or TB4-8 on the Interface Board where +/- 1000 in Mentor units = +/- 10 VDC. This is equivalent to using a digital multimeter at the terminal block and measuring +/- 0-10 VDC.

07.02 RO General Purpose Input 2

Range ± 1000

Displays the value of the analog signal applied to terminal TB1-5 on the Power Module or TB4-9 on the Interface Board where +/- 1000 in Mentor units = +/- 10 VDC. This is equivalent to using a digital multimeter at the terminal block and measuring +/- 0-10 VDC.

07.03 RO General Purpose Input 3

Range ± 1000

Displays the value of the analog signal applied to terminal TB1-6 on the Power Module or TB4-10 on the Interface Board where +/- 1000 in Mentor units = +/- 10 VDC. This is equivalent to using a digital multimeter at the terminal block and measuring +/- 0-10 VDC.

07.04 RO General Purpose Input 4

Range ±1000

Displays the value of the analog signal applied to terminal TB1-7 on the Power Module or TB4-11 on the Interface Board where +/- 1000 in Mentor units = +/- 10 VDC. This is equivalent to using a digital multimeter at the terminal block and measuring +/- 0-10 VDC.

07.05 RO Speed Reference Input

Range ±1000

Displays the value of the Primary Reference Input (Speed Ref. 1 TB1-3 on the Power Module or TB4-7 on the Interface Board where +/- 1000 in Mentor units = +/- Full Range. The Full Range is determined by which input is used (voltage, current, or encoder).

07.06 RO RMS Input Voltage

Range 0 to 1000

Monitors the 3 Phase Input to the drive (L1, L2, and L3) and provides the RMS Voltage level as a read-only. Reading Parameter 7.06 is equivalent to reading the phase to phase AC voltage using a digital voltmeter.

07.07 RO Heatsink Temperature

Range 0 to 1000

Displays the temperature (in degrees C) of the SCR stack via a thermocouple mounted on an SCR and terminated on the power board at PL2. Note : Deg. F = ((9/5)*deg C)+32. If the cabinet is designed properly with sufficient ventilation and cooling, Parameter 7.07 should always read low numbers (i.e. 20-30 deg C).

07.08 R/W DAC 1 Source

Range 0 to 1999 Default 302

Selects the source of analog output 1 via terminal TB2-12 on the Power Module or TB4-14 on the Interface Board. Remember, source parameters (in this case) define what information is sent out of the DAC terminal block (i.e. the information could be Armature Voltage, Armature Current, Speed Feedback, etc.). **Anytime a source parameter is changed or redefined the store procedure must be executed before the change takes effect!** The default of 302 represents Speed Feedback.

07.09 R/W DAC 2 Source

Range 0 to 1999 Default 304

Selects the source of analog output 2 via terminal TB2-13 on the Power Module or TB4-15 on the Interface Board. Remember, source parameters (in this case) define what information is sent out of the DAC terminal block (i.e. the information could be Armature Voltage, Armature Current, Speed Feedback, etc.). **Anytime a source parameter is changed or redefined the store procedure must be executed before the change takes effect!** The default of 304 represents Armature Voltage.

104 Parameter Descriptions

07.10 R/W DAC 3 Source

Range 0 to 1999 Default 603

Selects the source of analog output 3 via terminal TB2-14 on the Power Module or TB4-16 on the Interface Board. Remember, source parameters (in this case) define what information is sent out of the DAC terminal block (i.e. the information could be Armature Voltage, Armature Current, Speed Feedback, etc.). **Anytime a source parameter is changed or redefined the store procedure must be executed before the change takes effect!** The default of 603 represents Field Current Feedback.

07.11 R/W GP 1 Destination

Range 0 to 1999 Default 119

Selects the destination of analog input 1 via terminal TB1-4 on the Power Module or TB4-8 on the Interface Board. Remember, destination parameters (in this case) define where the +/- 10 VDC input is sent to (i.e. the input could be a ratio pot, trim pot, torque or tension pot, etc.). **Anytime a destination parameter is changed or redefined the store procedure must be executed before the change takes effect!** The default value of 119 represents Speed Reference 3. (Note that the Interface Board labels this input as Speed Reference 2). See the Menu 1 flowchart for more details.

07.12 R/W GP 2 Destination

Range 0 to 1999 Default 104

Selects the destination of analog input 1 via terminal TB1-5 on the Power Module or TB4-9 on the Interface Board. Remember, destination parameters (in this case) define where the +/- 10 VDC input is sent to (i.e. the input could be a ratio pot, trim pot, torque or tension pot, etc.). **Anytime a destination parameter is changed or redefined the store procedure must be executed before the change takes effect!** The default value of 104 represents Offset.

07.13 R/W GP 3 Destination

Range 0 to 1999 Default 408

Selects the destination of analog input 1 via terminal TB1-6 on the Power Module or TB4-10 on the Interface Board. Remember, destination parameters (in this case) define where the +/- 10 VDC input is sent to (i.e. the input could be a ratio pot, trim pot, torque or tension pot, etc.). **Anytime a destination parameter is changed or redefined the store procedure must be executed before the change takes effect!** The default value of 408 represents the Torque Reference (Effective when the drive is in Torque Mode).

07.14 R/W GP 4 Destination

Range 0 to 1999 Default 0

Selects the destination of analog input 1 via terminal TB1-7 on the Power Module or TB4-11 on the Interface Board. Remember, destination parameters (in this case) define where the +/- 10 VDC input is sent to (i.e. the input could be a ratio pot, trim pot, torque or tension pot, etc.). **Anytime a destination parameter is changed or redefined the store procedure must be executed before the change takes effect!** The default value of 0 represents no destination. (Note that the Interface Board labels this input as User Prog. Input.)

07.15 R/W Speed Reference Destination

Range 0 to 1999 Default 117

Selects the destination of the Primary Speed Reference (Speed Reference 1) via terminal TB1-3 on the Power Module or TB4-7 on the Interface Board. Remember, destination parameters (in this case) define where the +/- 10 VDC input is sent to (i.e. the input could be a ratio pot, trim pot, torque or tension pot, etc.). **Anytime a destination parameter is changed or redefined the store procedure must be executed before the change takes effect !** The default value of 117 represents Speed Reference 1. (See the Menu 1 flowchart for more details.

07.16 R/W GP 1 Scaling

Range 0 to 1999 Default +1000

Scales the GP1 analog input (TB1-4 on the Power Module or TB4-8 on the Interface Board). The Range of 0 to 1999 is equivalent to multiplying the analog input of +/- 0-1000 (as seen in the read-only P7.01) in Mentor units by 0 to 1.999 (approximately 2). This means that P7.16 set to 0 turns GP1 off and P7.16 set to 1999 doubles the analog input (+/- 5 VDC input would equate to +/- 10 VDC at this setting). The default of 1000 sets the GP1 scaling at 1 to 1 or 100 %.

$$\text{Scaling factor} = \frac{07.16}{1000}$$

07.17 R/W GP 2 Scaling

Range 0 to 1999 Default +1000

Scales the GP2 analog input (TB1-5 on the Power Module or TB4-9 on the Interface Board). The Range of 0 to 1999 is equivalent to multiplying the analog input of +/- 0-1000 (as seen in the read-only P7.02) in Mentor units by 0 to 1.999 (approximately 2). This means that P7.17 set to 0 turns GP2 off and P7.17 set to 1999 doubles the analog input (+/- 5 VDC input would equate to +/- 10 VDC at this setting). The default of 1000 sets the GP2 scaling at 1 to 1 or 100 %.

$$\text{Scaling factor} = \frac{07.17}{1000}$$

07.18 R/W GP 3 Scaling

Range 0 to 1999 Default +1000

Scales the GP3 analog input (TB1-6 on the Power Module or TB4-10 on the Interface Board). The Range of 0 to 1999 is equivalent to multiplying the analog input of +/- 0-1000 (as seen in the read-only P7.03) in Mentor units by 0 to 1.999 (approximately 2). This means that P7.18 set to 0 turns GP3 off and P7.18 set to 1999 doubles the analog input (+/- 5 VDC input would equate to +/- 10 VDC at this setting). The default of 1000 sets the GP3 scaling at 1 to 1 or 100 %.

$$\text{Scaling factor} = \frac{07.18}{1000}$$

106 Parameter Descriptions

07.19 R/W GP 4 Scaling

Range 0 to 1999 Default +1000

Scales the GP4 analog input (TB1-7 on the Power Module or TB4-11 on the Interface Board). The Range of 0 to 1999 is equivalent to multiplying the analog input of +/- 0-1000 (as seen in the read-only P7.04) in Mentor units by 0 to 1.999 (approximately 2). This means that P7.19 set to 0 turns GP4 off and P7.19 set to 1999 doubles the analog input (+/- 5 VDC input would equate to +/- 10 VDC at this setting). The default of 1000 sets the GP4 scaling at 1 to 1 or 100 %.

$$\text{Scaling factor} = \frac{07.19}{1000}$$

07.20 R/W Speed Reference Scaling

Range 0 to 1999 Default +1000

Scales the Primary Speed Reference (Speed Ref. 1) input (TB1-3 on the Power Module or TB4-7 on the Interface Board). The Range of 0 to 1999 is equivalent to multiplying the analog input of +/- 0-1000 (as seen in the read-only P7.05) in Mentor units by 0 to 1.999 (approximately 2). This means that P7.20 set to 0 turns Speed Ref. 1 off and P7.20 set to 1999 doubles the analog input (+/- 5 VDC input would equate to +/- 10 VDC at this setting). The default of 1000 sets the Speed Ref. 1 scaling at 1 to 1 or 100 %.

$$\text{Scaling factor} = \frac{07.20}{1000}$$

07.21 R/W DAC 1 Scaling

Range 0 to 1999 Default +1000

Scales the DAC 1 analog input (TB1-12 on the Power Module or TB4-14 on the Interface Board). The Range of 0 to 1999 is equivalent to multiplying the source parameter (+/- 0-1000 in Mentor units) by 0 to 1.999 (approximately 2). This means that P7.21 set to 0 turns DAC 1 output off and P7.21 set to 1999 doubles the source parameter (+/- 500 in Mentor units would equate to +/- 1000 or +/- 0-10VDC output at this setting. The default of 1000 sets the DAC 1 output scaling at 1 to 1 or 100 %.

$$\text{Scaling factor} = \frac{07.21}{1000}$$

07.22 R/W DAC 2 Scaling

Range 0 to 1999 Default +1000

Scales the DAC 2 analog input (TB1-13 on the Power Module or TB4-15 on the Interface Board). The Range of 0 to 1999 is equivalent to multiplying the source parameter (+/- 0-1000 in Mentor units) by 0 to 1.999 (approximately 2). This means that P7.22 set to 0 turns DAC 2 output off and P7.22 set to 1999 doubles the source parameter (+/- 500 in Mentor units would equate to +/- 1000 or +/- 0-10VDC output at this setting. The default of 1000 sets the DAC 2 output scaling at 1 to 1 or 100 %.

$$\text{Scaling factor} = \frac{07.22}{1000}$$

07.23 R/W DAC 3 Scaling

Range 0 to 1999 Default +1000

Scales the DAC 3 analog input (TB1-14 on the Power Module or TB4-16 on the Interface Board). The Range of 0 to 1999 is equivalent to multiplying the source parameter (+/- 0-1000 in Mentor units) by 0 to 1.999 (approximately 2). This means that P7.23 set to 0 turns DAC 3 output off and P7.23 set to 1999 doubles the source parameter (+/- 500 in Mentor units would equate to +/- 1000 or +/- 0-10VDC output at this setting. The default of 1000 sets the DAC 3 output scaling at 1 to 1 or 100 %.

$$\text{Scaling factor} = \frac{07.23}{1000}$$

07.24 R/W Reference Encoder Scaling

Range 0 to 1999 Default +419

Sets the scaling when the Primary Reference is an encoder (connected to terminal socket PL4). The scaling is based on the maximum speed the motor is expected to run in the application (usually the motor nameplate base speed) and the number of lines-per-revolution (often described as pulses-per-revolution) of the encoder. To calculate the scale factor -

$$\text{Scale factor} = \frac{750 \times 10^6}{N \times n}$$

where N = number of lines-per-revolution (encoder)
n = max speed of motor in rpm.

Default value is determined on the basis of a 1024 PPR encoder, and a maximum speed of 1750rpm. Using the same motor with a 600 PPR encoder, the scaling would be 714.

07.25 R/W Reference Encoder Selector

Default 0 analog reference selected

1 = encoder selected

Selects either the analog signal at terminal TB1-03 or the encoder input via PL4 as the source of speed reference signal.

108 Parameter Descriptions

07.26 R/W Current loop selector

Default 0 voltage input selected

Determines whether Speed Ref. 1 (TB1-03 on the Power Module or TB4-7 on the Interface Board) serves as a voltage or a current input.

07.27 R/W Current Loop Mode Selector 1

Default 0

Parameter 7.27 and 7.28 are used together to select the expected current input range when Parameter 7.26 is set to 1 (the Primary Reference Input is a current input). Note the table below. Also refer to the Reference Set-Up section of this manual.

07.28 R/W Current Loop Mode Selector 2

Default 0

Parameter 7.27 and 7.28 are used together to select the expected current input range when Parameter 7.26 is set to 1 (the Primary Reference Input is a current input). Note the table below. Also refer to the Reference Set-Up section of this manual.

Special Note !!!:

When a 4mA offset is used, the drive will trip if it senses that the current is less than 3.5mA indicating a 'Current Loop Loss'.

Current Loop Input Selection		
<u>Input</u>	<u>7.28</u>	<u>7.27</u>
0 – 20 mA	0	0
20 – 0 mA	0	1
4 – 20 mA	1	0
20 – 4 mA	1	1

MENU - 08 Digital Inputs

08.01 RO F1 Input - Run Permit

0 = stop drive

1 = start enabled

Monitors the drive start-permit control input from terminal TB3-21 and indicates status. This input performs an over-riding drive stop function in speed control mode as follows -

The input must be active in order that the drive can start.

If the input becomes inactive, 08.01 causes the pre-ramp reference 01.03 to be set to zero.

The drive will stop unless 02.03, ramp hold, is active.

08.02 RO F2 input - Default Inch Reverse

0 = input not active

1 = input active

Monitors the control input from terminal TB3-22 and indicates status. The drive will respond to this input as inch reverse command only if the external logic controls are enabled (08.21 = 0). Also its function is freely programmable.

08.03 RO F3 Input - Default Inch Forward

0 = input not active

1 = input active

Monitors the control input from terminal TB3-23 and indicates status. The drive will respond to this input as inch forward command only if the external logic controls are enabled (08.21 = 0). Also its function is freely programmable.

08.04 RO F4 Input - Default Run Reverse

0 = input not active

1 = input active

Monitors the control input from terminal TB3-24 and indicates status. The drive will respond to this input as run reverse command only if the external logic controls are enabled (08.21 = 0). Also its function is freely programmable.

This is a latched input - parameter 01.11 will not revert to 0 if the input is removed, provided that 08.21 = 0.

08.05 RO F5 Input - Default Run Forward

0 = input not active

1 = input active

Monitors the control input from terminal TB3-25 and indicates status. The drive will respond to this input as run forward command only if the external logic controls are enabled (08.21 = 0). Also its function is freely programmable.

This is a latched input - parameter 01.11 will not revert to 0 if the input is removed, provided that 08.21 = 0.

110 Parameter Descriptions

08.06 RO F6 Input - User Programmable

0 = input not active

1 = input active

Monitors the control input from terminal TB3-26 and indicates status.

08.07 RO F7 Input - User Programmable

0 = input not active

1 = input active

Monitors the control input from terminal TB3-27 and indicates status.

08.08 RO F8 Input - User Programmable

0 = input not active

1 = input active

Monitors the control input from terminal TB3-28 and indicates status.

08.09 RO F9 Input - User Programmable

0 = input not active

1 = input active

Monitors the control input from terminal TB3-29 and indicates status.

08.10 RO F10 Input - User Programmable

0 = input not active

1 = input active

Monitors the control input from terminal TB3-30 and indicates status.

08.11 RO Drive Enable Input

0 = disable

1 = enable

Monitors the drive enable input from terminal TB4-31 and indicates status. Input must be active for the drive to operate. When the drive is disabled by disconnecting the input, all firing pulses are switched off after a 30s delay. If the drive is running when this occurs, the result is a coast-stop and ramps reset.

08.12 R/W F2 Destination

Range

0 to 1999

Default +000

Defines the destination of external logic input at terminal TB3-22. Effective only after RESET.

08.13 R/W F3 Destination

Range

0 to 1999

Default +000

Defines the destination of external logic input at terminal TB3-23. Effective only after RESET.

08.14 R/W F4 Destination

Range

0 to 1999

Default +000

Defines the destination of external logic input at terminal TB3-25. Effective only after RESET

08.15 R/W F5 Destination

Range 0 to 1999 Default +000
Defines the destination of external logic input at terminal TB3-25.
Effective only after RESET.

08.16 R/W F6 Destination

Range 0 to 1999 Default +202
Defines the destination of external logic input at terminal TB3-26.
Effective only after RESET.

08.17 R/W F7 Destination

Range 0 to 1999 Default +1029
Defines the destination of external logic input at terminal TB3-27.
Effective only after RESET.

08.18 R/W F8 Destination

Range 0 to 1999 Default +115
Defines the destination of external logic input at terminal TB3-28.
Effective only after RESET.

08.19 R/W F9 Destination

Range 0 to 1999 Default +413
Defines the destination of external logic input at terminal TB3-29.
Effective only after RESET.

08.20 R/W F10 Destination

Range 0 to 1999 Default +518
Defines the destination of external logic input at terminal TB3-30.
Effective only after RESET.

08.21 R/W Disable Normal Logic Functions

0 = enable normal logic function 1 = disable normal logic function

Default 0
If set to enable (= 0), this parameter configures logic inputs in the following manner -

- F2 TB3-22 Inch Reverse
- F3 TB3-23 Inch Forward
- F4 TB3-24 Run Reverse
- F5 TB3-25 Run Forward

112 Parameter Descriptions

If set to disable (=1), the logic inputs must be programmed by the user.

If 08.21 = 0, F2/3/4/5 still perform their programmed functions.
See also parameters 08.31 to 08.34.

08.22 to 08.30 inclusive R/W Invert Inputs F2 to F10 inclusive respectively

0 = not invert (default) 1 = invert logic function

08.31 R/W Enable Inch Reverse

0 = not enable (default) 1 = enable Inch Reverse
When 08.21 = 1, normal logic functions disabled, 08.31 can enable Inch Rev.

08.32 R/W Enable Inch Forward

0 = not enable (default) 1 = enable Inch Forward
When 08.21 = 1, normal logic functions disabled, 08.31 can enable Inch Fwd.

08.33 R/W Enable Run Reverse

0 = not enable (default) 1 = enable Run Reverse
When 08.21 = 1, normal logic functions disabled, 08.31 can enable Run Rev.

08.34 R/W Enable Run Forward

0 = not enable (default) 1 = enable Run Forward
When 08.21 = 1, normal logic functions disabled, 08.31 can enable Run Fwd.

MENU 09 - Status Outputs

Status Output parameters define a parameter to be used as a source, thereby defining the function of programmable output terminals.

Menu 09 contains three status source groupings, and each is invertable. The two sources ST1 and ST2 can be combined in any convenient configuration for output to terminals TB2-15 and TB2-16. The second group selects from sources ST3, ST4, ST5 for output to TB2-17, TB2-18, TB2-19 respectively, or source ST6 (relay output). Delays 09.12 and 09.18 status outputs ST1 and ST2 in 0 ?? 1 transitions. In 1 to 0 transitions the effect immediate, without delay.

09.01 RO Status 1 Output

Range 0 to 1

Status 1 output ST1 to TB2-15.

09.02 RO Status 2 Output

Range 0 to 1

Status 2 output ST2 to TB2-16.

09.03 RO Status 3 Output

Range 0 to 1

Status 3 output ST3 to TB2-17.

09.04 RO Status 4 Output

Range 0 to 1

Status 4 output ST4 to TB2-18.

09.05 RO Status 5 Output

Range 0 to 1

Status 5 output ST5 to TB2-19.

09.06 RO Status 6 Output

Range 0 to 1

Output to form C relay at terminals TB4-34, 35, 36.

09.07 R/W Status 1 Source 1

Range 0 to 1999

Default 111

Selects the status source to be combined with 9.09 and displayed on TB2-15.

09.08 R/W Invert Status 1 Source 1

Range 0 to 1

Default 1

Selects inversion of input on 9.07.

09.09 R/W Status 1 Source 2

Range 0 to 1999

Default 000

Selects the status source to be combined with 9.07 and displayed on TB2-15.

09.10 R/W Invert Status 1 Source 2

Range 0 to 1

Default 1

Selects inversion of input of input on 9.09.

09.11 R/W Invert Status 1 Output

Range 0 to 1

Default 1 (invert)

Selects inversion of combination of 9.07 and 9.09.

114 Parameter Descriptions

09.12 R/W Status 1 Delay

Range 0 to 255 seconds

Default 0

Sets delay time for status 1 output.

09.13 R/W Status 2 Source 1

Range 0 to 1999

Default 1007

Selects the status source to be combined with 9.15 and displayed on TB2-16.

09.14 R/W Invert Status 2 Source 2

Range 0 to 1

Default 1

Selects inversion of input on 9.13.

09.15 R/W Status 2 Source 2

Range 0 to 1999

Default 000

Selects the status source to be combined with 9.13 and displayed on TB2-16.

09.16 R/W Invert Status 2 Source 2

Range 0 to 1

Default 1

Selects inversion of input on 9.15.

09.17 R/W Status 2 Output

Range 0 to 1

Default 1

Selects inversion of combination of 9.13 and 9.15.

09.18 R/W Status 2 Delay

Range 0 to 255 seconds

Default 000

Sets delay time for status 2 output.

09.19 R/W Status 3 Source

Range 0 to 1999

Default 1013

Selects the status source to be displayed on TB2-17.

09.20 R/W Invert Status 3 Output

Range 0 to 1

Default 0 (not inverted)

09.21 R/W Status 4 Source

Range 0 to 1999

Default 1009

Selects the status source to be displayed on TB3-18.

09.22 R/W Invert Status 4 Output

Range 0 to 1

Default 0 (not inverted)

09.23 R/W Status 5 Source

Range 0 to 1999

Default 1012

Selects the status source to be displayed on TB3-19.

09.24 R/W Invert Status 5 Output

Range 0 to 1

Default 1

09.25 R/W Status 6 Source – Relay Output

Range 0 to 1999

Default 1009

Selects the status source to activate relay to TB4-34, 35, 36.

09.26 R/W Invert Status 6 Output

Range 0 to 1

Default 0 (not inverted)

MENU 10 - Status Outputs

All real (not bit) RO parameters are frozen at the instant of tripping as an aid to diagnosis of the fault. They remain in this condition until the drive is reset.

10.01 RO Forward Velocity

0 = drive stationary or running in reverse

1 = drive running forward at >zero speed threshold

Forward direction defined as -

When tach feedback selected, terminal TB1-09 negative with respect to terminal TB1-10.

When armature voltage feedback selected, terminal A1 positive with respect to terminal A2.

When encoder feedback selected, A-channel leads B-channel.

116 Parameter Descriptions

10.02 RO Reverse Velocity

0 = drive stationary or running forward

1 = drive running in reverse at >zero speed threshold

Reverse direction defined as -

When tach feedback selected, terminal TB1-09 positive with respect to terminal TB1-10.

When armature voltage feedback selected, terminal A1 negative with respect to terminal A2.

When encoder feedback selected, A-channel lags B-channel.

NOTE if 10.01 = 10.02 = 0, the motor is either stationary or running at <zero speed threshold. In this condition, 10.09 = 1 and the Zero Speed LED illuminates on the keypad (and RL2 is energized, if programmed to indicate zero speed).

10.03 RO Current Limit

0 = drive not in current limit

1 = drive in current limit

Indicates that the sum of the current demand 04.01 and the offset 04.09 is being limited by the current limit over-ride 04.03 or one of the bridge limits.

10.04 RO Bridge 1 Enabled

0 = disabled

1 = enabled

Indicates that thyristor bridge 1 (the forward or positive bridge) is being fired. Does not necessarily indicate that the bridge is conducting, since conduction depends on firing angle and operating conditions.

10.05 RO Bridge 2 Enabled

0 = disabled

1 = enabled

Indicates that thyristor bridge 2 (the reverse or negative bridge) is being fired. Does not necessarily indicate that the bridge is conducting, since conduction depends on firing angle and operating conditions.

10.06 RO Electrical Phase-Back

0 = firing pulses not phased back

1 = firing pulses phased back (at standstill)

Indicates that the firing pulses are being phased back by the action of the standstill function. Refer to 05.18 and 05.19.

10.07 RO At Speed

0 = Drive not at speed 1 = drive at speed

Indicates that the drive has attained set speed, post-ramp reference 02.01 = pre-ramp reference 01.03, and also that comparison of final speed demand 03.01 with speed feedback 03.02 results in a speed error of <1.5% of maximum speed. External signal also provided through open collector output ST2 to terminal TB2-16 if source parameter 09.13 is at default setting.

10.08 RO Overspeed

0 = motor not overspeeding 1 = motor over speed

Indicates that the speed feedback 03.02 >+1000, that is, the speed is out of range, suggesting that the motor is being mechanically driven faster than the maximum speed of the drive. This function is a monitor only, and does not initiate a trip signal.

10.09 RO Zero Speed

0 = speed not zero 1 = zero speed

Set if speed feedback 03.02 <zero speed threshold 03.23. Refer to 10.01 and 10.02.

10.10 RO Armature Voltage Clamp Active

0 = clamp not active 1 = clamp active

Set when the armature voltage clamp is activated. Prevents the voltage from increasing further refer to 03.15.

10.11 RO Phase Rotation

0 = L1 L3 L2 1 = L1 L2 L3

Rotation is detected from L1, L2, L3. NOTE that connection to E1 and E3 must also be correct.

10.12 RO Drive Healthy

1 = drive is powered-up and has not tripped.

10.13 RO Alarm

0 = no alarm condition present

1 = alarm condition present, impending sustained-overload trip

Indicates that the drive is in an overload condition and will eventually trip on sustained overload 10.18 if the overload condition is not removed. The time taken to trip is dependent on the settings of 05.06 and 05.07 and on the magnitude of overload.

Visual indication that the alarm has been actuated is given by the Alarm LED (flashing). External signal also provided through status logic output ST3 to terminal TB2-17 - provided that source parameter 09.19 is at its default value.

118 Parameter Descriptions

10.14 RO Field Loss

0 = field healthy

1 = field failed

Indicates that no current is being drawn from the internal field supply (or the FXM5 option external field control module if installed). A delay of 0.5 seconds is applied to allow the field current to build up.

10.15 RO Feedback Loss

0 = speed feedback present

1 = speed feedback absent or polarity reversed

Indicates not feedback signal, or reversed polarity. Applies equally to tach-generator and encoder feedback, whichever is selected. Loss of feedback is not detected until the firing angle has advanced to the point where the value of 05.03 (firing angle) > 767. This condition can be prevented from tripping the drive by disabling feedback loss detection 10.30.

10.16 RO Supply or Phase Loss

0 = healthy

1 = supply/phase loss

Indicates loss of one or more input phases connected to L1, L2, L3. Can be disabled by means of 10.31.

10.17 RO Instantaneous Trip

0 = no overcurrent peak detected

1 = overcurrent peak detected

Indicates that a current peak > 2 x (max. current according to the burden resistor fitted) has occurred. The result is that firing pulses are immediately suppressed, shutting the drive down.

10.18 RO Sustained Overload

0 = sustained overload not detected

1 = sustained overload detected

Indicates that current feedback 05.01 has exceeded the overload threshold 05.06 for a length of time determined by the overload time values 05.07 and 05.08 integrated with the magnitude of the overload (the conventional $I \times t$ function).

When the current exceeds the overload threshold, the excess integrates with time causing the value of the actual overload 05.11 to increase.

Conversely, if the current falls below the threshold during integration, the value of 05.11 falls towards zero. The rate of integration is set by 05.07 when the current is > threshold, and by 05.08 when the current is < threshold. The rate of integration is the trip times with full scale overload (05.01 = 1000). This function imitates the behavior of a thermal relay and simulates the thermal characteristic of a motor.

10.19 RO Processor 1 Watchdog

0 = healthy

1 = trip

In normal operation of the drive the watchdog timer is reset periodically by Processor 1 as a check that the processor and drive program are functioning normally. If a reset does not occur before the timer has timed out the conclusion is either that the processor has failed or that the drive program has crashed. The result is immediate controlled shutdown of the drive, accompanied by a watchdog fault trip signal.

10.20 RO Processor 2 Watchdog

0 = healthy

1 = trip

10.21 RO Motor Overtemperature

0 = healthy

1 = trip

10.22 = 1 indicates thyristor stack over-temperature, > 100 degree C (on drives fitted with a thyristor stack heatsink thermistor).

10.22 Heatsink Overtemperature

0 = healthy

1 = trip

10.22 = 1 indicates thyristor stack over-temperature, > 100 degree C (on drives fitted with a thyristor stack heatsink thermistor).

10.23 RO Speed Loop Saturated

0 = speed loop not saturated

1 = speed loop saturated

Indicates that the output of the speed loop algorithm, from which the current demand 04.01 is derived, is at a limit. This may be due to the application of a current limit or a zero-current clamp, and may occur if the motor is mechanically stalled.

10.24 RO Zero Current Demand

0 = current demand > 0

1 = current demand = 0

Indicates that the current demand signal is being limited to zero. This could occur, for example, as a result of a sudden loss of load, the drive being in torque control mode with speed over-ride. The speed could reach the set speed threshold as a consequence, causing the speed loop to reduce the current demand to zero.

120 Parameter Descriptions

10.25 RO Last Trip

Range 0 to 255

Record of the last-trip code, forming the basis of a trip history.

10.26 RO The Trip Before the Last Trip (10.25)

Range 0 to 255

Record of the trip before that which is saved in 10.25.

10.27 RO The Trip Before 10.26

Range 0 to 255

Record of the trip before that which is saved in 10.26.

10.28 RO The Trip Before 10.27

Range 0 to 255

Record of the trip before that which is saved in 10.27.

The four parameters 10.25 to 10.28 provide a permanent memory of the last four trips. They are updated only by a new trip occurring.

10.29 R/W Disable Field Loss Trip

Default 0 field loss trip enabled

Prevents the drive from tripping when field loss is detected, for example, in applications where the internal field supply is not used or is switched off when the drive is not running.

10.30 R/W Disable Feedback Loss Trip

Default 0 feedback loss enabled

Prevents the drive from tripping when speed feedback loss is detected, for example in certain load-sharing applications and in applications which do not involve motors, such as battery charging and other electrolytic processes.

10.31 R/W Disable Supply or Phase Loss Trip

Default 0 supply/phase loss enabled

Prevents the drive from tripping when supply or supply phase loss is detected, allowing the drive to ride through brief supply interruptions.

10.32 R/W Disable Motor Overtemperature Trip

Default 0 supply/phase loss enabled

Prevents the drive from tripping when motor temperature sensor input changes to high resistance, for example when motor overtemperature protection is used in alarm mode, or to achieve a line normal stop.

10.33 R/W Disable Heatsink Overtemperature Trip

Default 0 heatsink over-temperature trip enabled

If parameter 10.33 is set to 1, the Heatsink Overtemperature Trip is disabled. This prevents the drive from tripping when heatsink temperature sensor detects a temperature greater than 100 degree C, for example when the thyristor heatsink over-temperature protection is used in the alarm mode, or to achieve a system normal stop. This is also useful on drives not fitted with fans and thermistors.

10.34 R/W External Trip

Default 0

If 10.34 = 1, the drive will trip. If an external trip is required, the user can program any logic input to control this bit (refer to Menu 08). Alternatively it can be controlled by application software or through the serial interface.

10.35 R/W Processor 2 Trip

Range 0 to 255

If the drive is healthy the data display for 10.35 is 0. The value of 10.35 is continuously monitored by the processor and the drive tripped immediately if a non-zero value (other than 255) appears via the serial communications interface, or Processor 2 software.

if 10.35 = 255, this is the equivalent of a RESET.

10.36 R/W Disable Current Loop Loss Trip

Default 0

When 10.36 = 1 the trip which normally would follow loss of the current loop is disabled.

10.37 R/W Disable Armature Open Trip

Default 0

When 10.37 = 1 the trip which normally would follow loss of the armature circuit is disabled. This is recommended in non-motor applications only.

122 Parameter Descriptions

MENU - 11 Miscellaneous

USER-DEFINED MENU

Parameters 11.01 through to 11.10 define the parameters in the user-defined MENU 00. For example, if the user wishes parameter 00.01 to display speed in rpm (03.03), parameter 11.01 (corresponding to 00.01) should be set to 303.

11.XX Parameter	0.XX Parameter	Description	Actual Parameter
11.01	0.01	Speed (RPM)	3.03
11.02	0.02	Max Speed Fwd	1.06
11.03	0.03	Max Speed Rev	1.09
11.04	0.04	Fwd Accel	2.04
11.05	0.05	Fwd Decel	2.05
11.06	0.06	I-Limit Fwd	4.05
11.07	0.07	I-Limit Rev	4.06
11.08	0.08	Jog Speed	1.05
11.09	0.09	IR Comp	3.17
11.10	0.10	Speed Loop P Gain	3.09

11.11 R/W Serial Address

Range 0 to 99 Default 001

Defines the unique address of a drive when several are connected to common serial bus in a multidrop application. If set > 100, the value is taken as 99.

11.12 R/W Baud Rate

Range 0 to 1 Default 0

Two Baud rates are available for the communications interface with the standard drives. Enter the 'setting' number appropriate to the required Baud rate as shown:

Baud	Setting
4800	0
9600	1

11.13 R/W Serial Mode

Range 1 to 3 Default 001

Defines the mode of operation of the serial port. There are three modes. Enter the 'setting' number appropriate to the required mode as shown:

	Mode	Setting
	ANSI protocol	1
Output variable defined by 11.19		2
Input variable into parameter defined by 11.19		3
Wide integer (16-bit) driver		4

Mode 1 is for communication between the drive and another serial device (terminal, plc, computer).

Mode settings 2 and 3 are for rapid transfer of information between two drives, avoiding the need for analog signals to pass between them. For example, mode settings 2 and 3 could be used in a load-sharing application to output the current demand from one drive in Mode 2 and input a current demand to another in Mode 3.

In **Mode 4** the drive will output the **wide** integer 15.63 to the transmit lines, and put any received data into 15.62. This permits a digital reference to be transmitted down a line of drives, and offers the possibility of setting ratios at each stage. Data must be transferred from 15.62 to 15.63 by a 'Basic' program. If a Wide Integer is read from the serial comms link, the data will be sent as five ASCII characters with no sign. (The full range of parameters can be written by five ASCII Characters so long as no sign is included). Data is transferred by mode 4 at the rate of 3 x mains frequency.

11.14 R/W Reserved

Range 0

Reserved for factory use.

11.15 RO Processor 1 Software Version

Range 0 to 255

Displays the revision number of the software installed in Processor 1. For example, version 1.0.0 is displayed as 10 (data window).

11.16 RO Processor 2 Software Version

Range 0 to 255

Reserved for processor 2 special application software (MD21 option PCB).

124 Parameter Descriptions

11.17 R/W Level 3 Security Code

Range 0 to 255 Default 149

If this parameter is changed (to any value other than 0 or 149) and stored, the value set must be entered into parameter 0 to return the drive to its 'as-delivered' state. Level 1 or Level 2 security must then be used in the normal way. If 11.17 is set = 0, all parameters are freely read-write accessible without the need to enter a security code. To store, set parameter 00 = 1 and press RESET.

11.18 R/W Boot-up Parameter

Range 0 to 1999 Default +000

Used for setting the parameter displayed at the keypad at power-on.

11.19 R/W Serial Programmable Source

Range 0 to 1999 Default +000

Defines an output or input parameter when serial mode 2 or 3 is selected. Refer to 11.13.

11.20 R/W Serial Scaling

Range 0 to 1999 Default +1000

Scales the input data in serial mode 3. Refer to 11.13.

11.21 R/W LEDs Byte

Range 0 to 255

Designations -

Bit 7	Alarm
Bit 6	Zero speed
Bit 5	Run forward
Bit 4	Run reverse
Bit 3	Bridge 1
Bit 2	Bridge 2
Bit 1	At speed
Bit 0	Current limit

The displayed value is the decimal equivalent of the bit-pattern.

11.22 R/W Disable Normal LED Functions

Default 0 enabled

Disables the normal functions of the keypad LED indicators (with the exception of Drive Ready) and renders them programmable. By setting 11.22 = 1, normal LED functions (with the exception of Drive Ready) can be controlled via the serial interface or processor 2 special application software. The LEDs display the binary equivalent of the value in 11.21.

11.23 R/W Permissive for MDA6 Issue 3

If the MDA6 Issue 3 power board is to be used for a high voltage MENTOR II, this parameter must be set to 1.

MENU 12 – Programmable Thresholds

12.01 RO Threshold 1 Exceeded

0 = healthy 1 = threshold exceeded

12.02 RO Threshold 2 Exceeded

0 = healthy 1 = threshold exceeded

12.03 R/W Threshold 1 Source

Range 0 to 199 Default +706

12.04 R/W Threshold 1 Level

Range 0 to 1000 Default +510

12.05 R/W Threshold 1 Hysteresis

Range 0 to 255 Default 001

12.06 R/W Invert Threshold 1 Output

0 = default 1 = signal inverted

12.07 R/W Threshold 1 Destination

Range 0 to 1999 Default +1034

12.08 R/W threshold 2 Source

Range 0 to 1999 Default +501

126 Parameter Descriptions

12.09 R/W Threshold 2 Level

Range 0 to 1000 Default +000

12.10 R/W Threshold 2 Hysteresis

Range 0 to 255 Default 002

12.11 R/W Invert Threshold 2 Output

0 = default 1 = signal inverted

12.12 R/W Threshold 2 Destination

Range 0 to Default +000

MENU 13 - Digital Lock

Menu 13 is a built-in special application software package which facilitates electronic line shaft simulation. This software package is known as Digital or "Shaft" Lock. For applications where a thumbwheel switch is desired to provide a ratio to the follower drive, the MD29 co-processor board is available with the enhanced Digital Lock software. (Part # M4992-5).

13.01 RO Master (Reference) Encoder Value

Range 0 to 1023

Displays the raw encoder pulse count from the encoder reference input (PL4).

13.02 RO Follower Encoder (Feedback Encoder) Value

Range 0 to 1023

Displays the raw encoder pulse count from the encoder feedback input (PL3 or SK3).

13.03 RO Master Counter Increment

Range ±1000

Displays same information as parameter 13.01.

13.04 RO Slave Counter Increment

Range ±1000

Displays same information as parameter 13.02.

13.05 RO Position Error

Range 0 to 255 (+/-)

Displays the master (reference) encoder pulse count minus the follower (feedback) encoder pulse count. This is, by definition, the difference between the position the follower is expected to be at and its actual position.

13.06 R/W Precision Reference Offset - see also **13.07**, **13.12** and **13.13**

Range 0 to 255

Provides an offset where a digital pre-set is used as an alternative to following an encoder. See parameter 13.07 for further description.

13.07 R/W Precision Reference Scaling - see also **13.06**, **13.12** and **13.13**

Range 0 to 255

Parameters **13.06** and **13.07** are used, in conjunction with each other, to define a 16-bit Digital preset (velocity) Precision reference when parameter 13.12 (Reference Source) = 0. Parameter 13.07 serves as the scaling (or gain) for the Precision Reference.

Each unit of 13.07 represents 256 increments of 13.06. This accounts for the fact that since the preset is 16 bits in resolution ($2^{16} = 65536$),

$$\text{Precision Reference} = 13.07 * 256 + 13.06$$

If 13.07=255 and 13.06=255 (max. values), then the Precision Reference will equal 65535 or approximately full scale.

13.08 R/W Position Gain

Range 0 to 255

The Position Gain (13.08) sets the amount of gain applied to the position error (13.05) which yields a correction term. A correction limit (clamp) is applied on the correction term and the result is added to the final speed demand via parameter 3.18. In this way, the correction term advances or retards the velocity of the drive in small "bursts or pulses" to bring the actual position of the follower back in line with the master's desired position. This could also be described as forcing the follower's pulse train to fall into phase with the master's pulse train.

13.09 R/W Position Loop Correction Limit

Range 0 to 1000

Limits the amount of correction term sent to the final speed demand as to prevent over-correction (when the "bursts or pulses" are sent to the final speed demand in the velocity loop).

128 Parameter Descriptions

13.10 R/W Position Software Enable

0 = disabled 1 = enabled

Enables the Position software (allowing the software to interact with the drive operation).

13.11 R/W Rigid Lock (Position Control) Enable

0 = disabled 1 = enabled

When 13.11 = 1, the position error is relative to the time the position correction enable is activated. When 13.11 = 0 (default), the position correction enable is activated only when the "At Speed" condition is reached (Status Parameter 10.07, RO, At Speed). This allows the Accel Ramps to be used without overspeeding the follower due to position correction. Note in the case where 13.11=1, that if the follower output shaft slows down due to overloading, the positional regulation will recover by an automatic speed increase when the overload is alleviated (the drive is out of current limit).

13.12 R/W Master Reference Selector

0 = master encoder 1 = precision reference

Selects either the Master Encoder Reference (13.01) or the Precision Reference (13.06 and 13.07) as the master reference in the Digital ("Shaft") Lock control loop.

13.13 R/W Precision Reference Latch

0 = use last values 1 = use updated values

The two Precision Reference values, 13.06 and 13.07, cannot be changed simultaneously. To prevent the Position Loop from reading inconsistent values during the change, parameter 13.13 = 0 (default) allows the Position Loop to continue using the last effective values while the change is taking place. When a change of both 13.06 and 13.07 has been completed, setting 13.13 = 1 causes the updated values to be applied. Parameter 13.13 should then be manually reset to 0 to be ready for the next update.

13.14 R/W Precision Speed Reference (16-bit)

Range 000 to 255

This parameter is a 'wide integer' equivalent to the Precision Reference 13.06 and 13.07, and allows the precision reference to be written to a single parameter removing the need for the latch, parameter 13.13. In this case, 13.06 and 13.07 should be manually set to zero.

Note : Parameter 13.14 is intended primarily for use through serial communications.

MENU 14 MD29 Set-Up

M4000 Manual MD29 updates:

Note: If the M4000 drive has the MD29 bd. Option it is mandatory that the parameters below are set properly or a “A29” fault may occur. Follow this instruction sheet carefully!

Parameter Table:

Menu 14 MD29 System Set-up				
Number	Description	Range	Type	Default
14.01	ANSI Serial Address	1 to 99	R/W	0
14.02	RS485 Mode	1 to 8	R/W	1
14.03	RS485 Baud Rate	24,48,96,or 192	R/W	48
14.04	Clock Section	0 to 100mS	R/W	5
14.06	Auto Run Mode	0 or 1	R/W	1
14.07	Trip if DPL Section Overrun	0 or 1	R/W	1
14.08	Trip if CT I/O box Link Fails	0 or 1	R/W	0
14.09	Enable Watchdog Timer for MD29	0 or 1	R/W	1
14.10	Trip if a Parameter Write Over-Ranges	0 or 1	R/W	1
14.11	Enable Dumb Terminal Mode	0 or 1	R/W	0
14.12	Clock Section Overrun Indicator	0 or 1	R/W	1
14.13	Encoder Section Overrun Indicator	0 or 1	R/W	1
14.14	Encoder Time Base Select	0 or 1	R/W	0

Parameter definitions:

14.01 This parameter defines the address for RS485 communications. Set “0” for Global.

14.02 This parameter sets the Mode for RS485 communications. All Modes except Mode 7 are fixed in the format: 1 Start bit, 7 Data bits, Even parity, 1 Stop bit.

1 = Standard 4-wire RS485, ANSI protocol

2 = Master Mode. A binary protocol is used to continually transfer a parameter (specified by an MD29 set-up parameter Mode 2/3 serial pointer) to another drive.

3 = Slave Mode. The MD29 reviews data, applies a scaling (specified by parameter Mode 3 serial scaling) and places the final value in a parameter specified by the MD29 set-up parameter Mode 2/3 serial pointer.

4 = Not Supported

130 Parameter Descriptions

5 = 2-Wire RS485, ANSI protocol

6 = User Mode. This Mode turns off all internal protocols and allows the user to use the RS485 port directly from the DPL program. Typically, this Mode will be used in conjunction with the DPL ANSI master commands (ANSIREAD, ANSIWRITE, etc.), however user defined protocols can also be implemented in DPL with the low level PUTCHAR and GETCHAR commands. The communication data-frame is organized as a 1 start bit, 7 data bits, even parity, and 1 stop bit (10 bit total).

7 = User Mode. This Mode turns off all internal protocols and allows the user to read and write directly from the ANSI port using the PUTCHAR and GETCHAR functions. The communication data-frame is organized as a 1 start bit, 8 data bits, even parity, and 1 stop bit (11 bit total).

8 = Same as Mode 7. 1 start bit, 8 data bits, No parity, and 1 stop bit

- 14.03 This Parameter sets the baud rate: 24 = 2400, 48 = 4800, 96=9600, and 192=19200.
- 14.04 Define the clock-tick time in milliseconds for executing the CLOCK Task of a DPL program. 0 gives a clock-tick of 0.5mS.
- 14.06 When set to a 1, this parameter enables a DPL program to be automatically started when the MD29 is reset or powered up. When set to a zero, a command must be issued from the MD29 tool kit software before the DPL program will start.
- 14.07 When set to a 1, this parameter causes the MD29 to trip and stop if a Task over-runs. There is no controlled stop. The display will show "A29".
- 14.08 When set to a 1, this parameter causes the MD29 to trip if there is a communication link failure between the MD29 and the CT I/O box.
- 14.09 When this parameter is set to a 1, the drive will trip if a fault occurs in the MD29 hardware or software. A user's DPL program cannot cause this trip.
- 14.10 Each drive parameter has a finite range of values which can be accepted. Any value which is outside the parameter limits could signify a program failure. When this parameter is set to a 1, the drive will trip if a parameter is outside the limits. When is set at 0, the MD29 places a limit on the value written.
- 14.11 Setting this parameter to a 1 puts the RS232 serial port into plain ASCII mode, and disables all the communication protocols for debugging and using the MD29 toolkit.
- 14.12 When this parameter is set to a 1, the MD29 indicates if the CLOCK Task overruns.
- 14.13 When this parameter is set at a 1, the MD29 indicates if the ENCODER Task overruns.
- 14.14 This parameter sets the time base for the ENCODER Task. 0 = 5mS or 1 = 2.5mS

MENU 15 - Application Menu 1

(See Related Corresponding Application Software Manual For More Info.)

Parameter #	Description	Range	Default
15.01	RO Variable 1	+/- 1999	
15.02	RO Variable 2	+/- 1999	
15.03	RO Variable 3	+/- 1999	
15.04	RO Variable 4	+/- 1999	
15.05	RO Variable 5	+/- 1999	
15.06	Real R/W Variable 1	+/- 1999	
15.07	Real R/W Variable 2	+/- 1999	
15.08	Real R/W Variable 3	+/- 1999	
15.09	Real R/W Variable 4	+/- 1999	
15.10	Real R/W Variable 5	+/- 1999	
15.11	Integer R/W Variable 1	0-255	
15.12	Integer R/W Variable 2	0-255	
15.13	Integer R/W Variable 3	0-255	
15.14	Integer R/W Variable 4	0-255	
15.15	Integer R/W Variable 5	0-255	
15.16	Integer R/W Variable 6	0-255	
15.17	Integer R/W Variable 7	0-255	
15.18	Integer R/W Variable 8	0-255	
15.19	Integer R/W Variable 9	0-255	
15.20	Integer R/W Variable 10	0-255	
15.21	Bit Variable 1	0-1	
15.22	Bit Variable 2	0-1	
15.23	Bit Variable 3	0-1	
15.24	Bit Variable 4	0-1	
15.25	Bit Variable 5	0-1	
15.26	Bit Variable 6	0-1	
15.27	Bit Variable 7	0-1	
15.28	Bit Variable 8	0-1	
15.29	Bit Variable 9	0-1	
15.30	Bit Variable 10	0-1	
15.31	Bit Variable 11	0-1	
15.32	Bit Variable 12	0-1	
15.33	Bit Variable 13	0-1	
15.34	Bit Variable 14	0-1	
15.35	Bit Variable 15	0-1	
15.36	Bit Variable 16	0-1	

132 Parameter Descriptions

MENU 15 - Application Menu 1

(See Related Corresponding Application Software Manual For More Info.)

Parameter #	Description	Range	Default
15.37	Reserved For Future Use		
15.38	Reserved For Future Use		
15.39	Reserved For Future Use		
15.40	Reserved For Future Use		
15.41	Reserved For Future Use		
15.42	Reserved For Future Use		
15.43	Reserved For Future Use		
15.44	Reserved For Future Use		
15.45	Reserved For Future Use		
15.46	Reserved For Future Use		
15.47	Reserved For Future Use		
15.48	Reserved For Future Use		
15.49	Reserved For Future Use		
15.50	Reserved For Future Use		
15.51	Reserved For Future Use		
15.52	Reserved For Future Use		
15.53	Reserved For Future Use		
15.54	Reserved For Future Use		
15.55	Reserved For Future Use		
15.56	Reserved For Future Use		
15.57	Reserved For Future Use		
15.58	Reserved For Future Use		
15.59	Reserved For Future Use		
15.60	Reserved For Future Use		
15.61	Reserved For Future Use		
15.62	Reserved For Future Use		
15.63	Reserved For Future Use		

MENU 16 - Application Menu 2

(See Related Corresponding Application Software Manual For More Info.)

Parameter #	Description	Range	Default
16.01	RO Variable 1	+/- 1999	
16.02	RO Variable 2	+/- 1999	
16.03	RO Variable 3	+/- 1999	
16.04	RO Variable 4	+/- 1999	
16.05	RO Variable 5	+/- 1999	
16.06	Real R/W Variable 1	+/- 1999	
16.07	Real R/W Variable 2	+/- 1999	
16.08	Real R/W Variable 3	+/- 1999	
16.09	Real R/W Variable 4	+/- 1999	
16.10	Real R/W Variable 5	+/- 1999	
16.11	Integer R/W Variable 1	0-255	
16.12	Integer R/W Variable 2	0-255	
16.13	Integer R/W Variable 3	0-255	
16.14	Integer R/W Variable 4	0-255	
16.15	Integer R/W Variable 5	0-255	
16.16	Integer R/W Variable 6	0-255	
16.17	Integer R/W Variable 7	0-255	
16.18	Integer R/W Variable 8	0-255	
16.19	Integer R/W Variable 9	0-255	
16.20	Integer R/W Variable 10	0-255	
16.21	Bit Variable 1	0-1	
16.22	Bit Variable 2	0-1	
16.23	Bit Variable 3	0-1	
16.24	Bit Variable 4	0-1	
16.25	Bit Variable 5	0-1	
16.26	Bit Variable 6	0-1	
16.27	Bit Variable 7	0-1	
16.28	Bit Variable 8	0-1	
16.29	Bit Variable 9	0-1	
16.30	Bit Variable 10	0-1	
16.31	Bit Variable 11	0-1	
16.32	Bit Variable 12	0-1	
16.33	Bit Variable 13	0-1	
16.34	Bit Variable 14	0-1	
16.35	Bit Variable 15	0-1	
16.36	Bit Variable 16	0-1	

134 Parameter Descriptions

MENU 16 - Application Menu 2

(See Related Corresponding Application Software Manual For More Info.)

Parameter #	Description	Range	Default
16.37	Reserved For Future Use		
16.38	Reserved For Future Use		
16.39	Reserved For Future Use		
16.40	Reserved For Future Use		
16.41	Reserved For Future Use		
16.42	Reserved For Future Use		
16.43	Reserved For Future Use		
16.44	Reserved For Future Use		
16.45	Reserved For Future Use		
16.46	Reserved For Future Use		
16.47	Reserved For Future Use		
16.48	Reserved For Future Use		
16.49	Reserved For Future Use		
16.50	Reserved For Future Use		
16.51	Reserved For Future Use		
16.52	Reserved For Future Use		
16.53	Reserved For Future Use		
16.54	Reserved For Future Use		
16.55	Reserved For Future Use		
16.56	Reserved For Future Use		
16.57	Reserved For Future Use		
16.58	Reserved For Future Use		
16.59	Reserved For Future Use		
16.60	Reserved For Future Use		
16.61	Reserved For Future Use		
16.62	Reserved For Future Use		
16.63	Reserved For Future Use		

START-UP GUIDELINES : General Wiring and Inspection

The following section is offered as reference to proper start-up procedures. It is important that the start-up personnel adhere to the following warnings:

Because of the high voltages and currents present in the drive, the following conditions must be met to assure a trouble-free and safe start-up:

DANGER

The start-up, calibration, and servicing of this equipment should be performed only by personnel familiar with electronic equipment, the equipment in the drive system, related machinery, and the potential hazards involved. Failure to observe this warning can result in serious personal injury or death, and/or equipment damage.

These procedures describe the installation of the M4000 Controller. Many also apply to the installation of the Drive Module. The engineer designing this package around the Drive Module must carefully read all the considerations and procedures and decide which apply to his application.

CAUTION

In cases where the M4000 Drive Module is integrated into a customer-designed drive system, the buyer is responsible for the correct choice of required associated equipment. Incorrectly specified components may cause improper operation and/or damage to the Drive Module.

WARNING

Only qualified maintenance personnel should install the Drive Module or Controller. They should be familiar with drive systems, including their operation, and with the possible hazards resulting from improper installation practices. Serious personal injury and/or equipment damage could result if this warning is not observed.

136 Start-Up Guidelines

DANGER

The user is responsible for installation of the entire drive system according to the National Electrical Code, Publication NFPA No. 70; with Electrical Standards for Metalworking Machine Tools, NFPA No. 79; and with all local and national codes which apply. Serious personal injury, death and/or equipment damage could result if this procedure is not followed.

The start-up sequence is summarized as follows:

1. Test Equipment
2. Mounting The Controller
3. Recommended Wiring Methods
 - a) EMI (Electrical Magnetic Interference)
 - b) Single Point Ground
 - c) Raceways
 - d) Incoming Power – Line Reactors or Isolation Transformers
 - e) Motor Lead Length
 - f) Field Connections
 - g) Motor Thermostat
 - h) Shielded Wire
 - i) Snubbers
4. Visual Inspection
5. Motor Inspection
6. Isolation Transformer Inspection
7. Incoming AC Line Verification
8. Power-Up And Voltage Checks
 - a) AC Power To Drive
 - b) Motor Field Supply
 - c) Cooling Fans (Where Applicable)
9. Power Module Operators And Logic
10. Motor Rotation

A. TEST EQUIPMENT

Recommended test equipment is listed in table 4.A. Because of the high voltages present in the drive system, exercise extreme caution when using the equipment.

DANGER

Use only the recommended test instruments, or equivalents, when performing service on a M4000 drive system. Failure to observe this warning can cause serious personal injury, death and/or damage to the equipment.

Table 4.A

Recommended Test Equipment

Equipment	Manufacturer	Type
Multimeter (VOM)	Simpson Triplet	260 630
or Digital Multimeter	Fluke	87
Oscilloscope 1)	Phillips	3212
DC Ammeter 2)	Various	Clamp
Megohmmeter	Megger	

- 1) An oscilloscope is not essential to the installation, start up or maintenance of a M4000 system, although it may be useful.
- 2) Must be capable of 150% of rated armature current. (See Table 1.C)

Isolated equipment which does not electrically common the case with these test leads is highly recommended. If a non-isolated oscilloscope or multimeter is used, it must be treated as potentially live and dangerous equipment. Keep in mind that other plant personnel may not be aware of the danger. Always clearly label the oscilloscope as dangerous and, whenever possible, restrict unnecessary personnel from the area.

B. MOUNTING CONTROLLER

Mounting

The M4000 Controller must be mounted in a vertical and upright position.

Drill patterns and dimensions for the Packaged Controller and Drive Module are shown in Figure 2.A, 2.B, and 2.C.

Be certain that the mounting area provides the environmental conditions noted in the following paragraphs.

Altitude

Altitude should not exceed 1000 meters (3300 ft) above sea level unless the M4000 unit has been specially sized for such duty.

Ambient Temperature

The drive module and chassis units should not be installed where ambient temperature will exceed 55°C (131°F). Enclosed units must not be installed where ambient will exceed 40°C (104°F). Never mount the unit in direct sunlight.

138 Start-Up Guidelines

Mounting Environment

Ambient air should not be contaminated by caustic chemical vapors, excessive dust, dirt, or moisture. If such conditions exist, the proper cooling methods and enclosures recommended should be used.

Mounting Clearances

Adequate clearance should be allowed for easy access to terminals and adjustments, and to facilitate inspection and maintenance.

Mounting Area

Mounting area must be free from vibration and have sufficient clear air circulation available.

C. RECOMMENDED WIRING METHODS

Electrical Magnetic Interference, EMI, is generated by equipment, such as drives and power supplies, used in and around a system. EMI has always had an effect on control systems, but as the equipment becomes more complex; reducing the effect of EMI has become more important. Your system has been designed to reduce EMI emissions and susceptibility. The following guidelines in installing your system should be followed to help maintain this quality:

Single Point Ground - Electrical earth ground should arrive to the control cabinet as a single insulated wire from a known good ground. A grounding electrode conductor or bonding jumper must be run unbroken from the star connection point to a grounding electrode buried in the earth or attached to a plant ground. (See NFPA No. 70, Article 250: "Grounding".) A permanent connection which cannot be accidentally broken must be provided. These components include, but are not necessarily limited to: Motor, Drive Enclosure, Isolation Transformer Case and Operator Control Panel.

The known good ground should be independent and distant from grounds for power distribution equipment that are not serving the system. It is best if the ground is run directly from the building service ground. If a known good ground is not available or questionable, drive a 10' ground rod at the cabinet and use in addition to the distribution ground. Wire gauge should be the same, or if the distance from the known good ground to the system cabinet is long, wire gauge should be larger than the service conductor. Use stranded wire, welding wire is the best. Keep the ground wire short as possible. All system grounds should be run back to the system panel in star fashion not series or "daisy chain".

Race Ways - Wire between the system cabinet and the machine can be divided into four groups; Power wire (Motors, Fans, wire with current larger than 1 Amp), 120 Volt Control (Start/stop buttons, pilot lights, limit switches, wire with less than 1 Amp), Analog (Speed pots, Line speed ref. signals, -10 to +10 volts, 24V control), and Serial/Encoder (RS485, RS232, Encoders, Pulse Tachs, TTL or digital signals). Unless indicated by notes on the drawings, Analog and serial/encoder signals can be run in the same race way. Control should be run by itself and never include any of the other 3 groups with the power wire. Always use metal race ways, and do not rely on the metal race way as a ground. If wire tray is used, separate the last 3 groups by 12" from the power wire with the 120v control between the analog/serial/encoder and the power wire, or use a shielding divider with as much gap as possible. When AC drives are used, separate

each set of motor leads in individual metal race way, or use shielded power wire with the shield connected to ground at both ends. Keep motor wires inside system cabinet as short and direct as possible. If wires must intersect with analog/serial/encoder wire, this intersection should be done at a right angle.

Incoming Power - LINE REACTORS OR ISOLATION TRANSFORMERS

Although not required in many cases, in installations where the AC line impedance is unacceptably low, isolation transformers or less costly line reactors should be used. Usually unacceptable line impedance comes about by wiring the drive directly to the secondary of a large capacity distribution transformer. **If the KVA rating of the distribution transformer is over 5 times the rating of the drive, line reactors or a correctly sized isolation transformer should be installed.** Consult Danaher Motion Engineered Systems Center for information on application and availability of these items.

When isolation transformers are used, it is essential that the primary winding of the transformer is delta configuration, and the secondary winding is WYE configuration in order to guard against the effects of third harmonic ripple voltages. Ground the neutral of the secondary winding only if required. It is recommended that a corner-grounded delta arrangement NOT be used to supply the M4000.

It is best to use an isolation transformer between the control system and the building power. The transformer size should not be larger than 5 times the rating of the drive. In the case of multi-drive systems, more than 1 isolation transformer may be required. The next best thing is an isolation transformer supplying the control system and individual AC reactors between drives. Make sure the power leads are the same length and use twisted power wire when possible. Keep the power wires inside the system cabinet as short as possible. Generally a fused disconnect switch must be installed in accordance with local, state, and National Electric Codes. If an isolation transformer is to be used, wire the fused disconnect switch ahead of its primary. In addition to satisfying code, wiring run length and size must be selected so that rated voltage is maintained at the input terminals of the M4000.

Mounting Environment

The transformer(s), if used, should be mounted in a way that permits proper ventilation. Be certain that the installation area provides the following environmental conditions:

- Ambient temperature should not exceed 40°C (104°F)
- Altitude should not exceed 1000 meters (3300 ft.) unless specified.
- Ambient air should not be contaminated with caustic chemical vapors, excessive dust, dirt or moisture.
- Adequate clearance to allow easy access for inspection and maintenance should be allowed.
- Sufficient air circulation for cooling must be provided.

Field Connections- Regarding a DC motor with a series field: Normally, these connections should be made in accordance with the motor nameplate. The one exception is for a REVERSING or REGENERATIVE model M4000. The series field is neither required nor permitted when these types of drives are used. If a series field is present, generally marked S1 and S2, do not connect these leads, but carefully insulate them from each other and from any other connection. Failure to do so will result in unstable operation, high armature currents, and erratic speeds.

140 Start-Up Guidelines

Motor Thermostat- If the motor has additional leads for a thermostat, usually labelled P1 and P2, these leads should be connected to the M4000 stop loop so that if the motor thermal opens indicating an overheated motor, the drive will shut down.

Shielded Wire - Use 100% shielded cable when possible. Connect the shield to ground at the power source only, except for encoder wire where the shield at the encoder end should be connected at the shield pin of the encoder connector and the shield at the system cabinet connected to earth. Pay attention to the drawings to make sure the twisted pairs are connected to the correct signal pairs. Keep the unshielded wires, where the shield has been removed at the end of the cable, as short as possible. Use the following table to select the cable type for the specific job unless a cable is specified in the drawing notes:

Analog signals -	2 conductor Belden #9322, Olympic #3140 3 conductor Belden #9363, Olympic #3160
Encoder signals -	Belden #9513, Olympic #3173
RS485/RS422 serial signals -	Half Duplex Belden #9842, Olympic #3950 Full Duplex Belden #9844, Olympic #3952
SV3000 Syc. Ser.-	Distance > 30' Belden #1538A
Power wire -	HWC (1-800-HOU-WIRE) #D160YYZZ YY = wire size AWG(limited selection) ZZ = number of conductors

Shielded cable is recommended for connection of the tach generator, speed potentiometer, encoder, serial communication, indicating meters, and all low level signal circuits to eliminate the possibility of electrical interference. The shield must be connected to ground at the end where connections are made to the M4000 only. The shield at the other end should be insulated and not connected to anything.

Snubbers - All relay, starter, and solenoid coils used within the enclosure of the M4000 must be suppressed to avoid electrical interference with the drive's functions. For 115 VAC or 230 VAC coils, use suppressor part number PCA1028-00 or equivalent. An equivalent would consist of a 100 Ω /1W resistor and 0.47 μ F 600 volt capacitor in a common package, or connected in series. For coil voltages higher than 230 VAC, consult Danaher Motion Engineered Systems Center. A snubber is a device used to absorb electrical noise generated when inductive devices like a relay or a solenoid is turned on or off. The snubber needs to be installed at the device. All inductive devices inside the system cabinet are snubbed, but field installed devices will need to have a snubber installed at the device by the customer. Most contactor and solenoid manufacturers offer snubbers to be used with their products. If not, for devices with less than 1/2 amp of holding current use RIFA part number PMR209MC6100M047 (0.1 μ F/47 μ), or devices with 1/2 to 2 amps of holding current use RIFA part number PMR209ME6470M047 (0.47 μ F/47 μ). Contact Danaher Motion if these devices are not available.

D. VISUAL INSPECTION

This paragraph discusses the visual inspections which must be carried out while AC power is off. It may be considered as an inspection of proper installation practices and possible transit damage. Each procedure has a convenient space provided at its immediate left. Be sure to check off each after performing the step. In this way no procedure will be overlooked.

DANGER

Before proceeding further, make sure that main machine disconnect switch is turned off and locked out. With a VOM measure the High-Voltage Area and Control Assembly's terminals to make sure no voltages are present in the equipment.

DANGER

High voltage may, in some drives, exist in the enclosure after the main machine disconnect is opened. Wiring codes dictate the use of yellow insulation on wires not controlled by the switch. Find the source for those wires, and remove power. Serious personal injury can result if this caution is not followed.

1. Inspect AC power connections to Terminals L1, L2, and L3 to assure integrity and tighten connections.
2. Inspect the Controller, especially the components mounted on the heatsinks, for possible physical damage, and to make sure that connections are secure.
3. Inspect the Controller for foreign matter, e.g., nuts bolts, washers, pieces of wire, metal chips, paper etc., and remove. Insure that the Heatsink Blower, if fitted, is undamaged and can turn freely.
4. Inspect underside of printed circuit cards for foreign matter and remove.
5. Inspect the front side of the printed circuit card for possible physical damage. Be sure that all wired connections, including the edge connectors are secure and tight.
6. Check the Dynamic Braking (D.B.) resistors, if furnished, for tightness of mounting hardware and electrical connections.
7. Check Armature Contactor for damage and for correct connections.
8. Inspect all other assemblies for damage, foreign matter, and check that connections to them are secure.
9. Refer to the system drawing in order to determine the exact model of the controller. Then refer to the wiring diagram which applies. With it, make sure the wiring is correctly installed.

142 Start-Up Guidelines

E. MOTOR INSPECTION

1. This paragraph provides a checklist of both mechanical and electrical motor inspection procedures. Be sure to check off each item after completion to insure that no procedure will be overlooked.
2. If possible, turn the motor armature by hand to insure freeness of rotation.
3. Inspect the tachometer generator and coupling (if provided) for damage and alignment and secure mechanical and electrical connections.
4. On reversing drives, motor armature leads A1 and A2 are connected to respective controller terminals A1 and A2.
5. Motor shunt field lead F1 is connected to Controller Terminal F1, and all motor shunt field leads are connected in the circuit as instructed under installation wiring.
6. Motor thermal switch leads P1 and P2 (if furnished) are connected properly in series with the STOP button.
7. Inspect AC blower motor (if provided) for damage, free rotation and proper connection.
8. With motor disconnected from drive, check for ground leakage, using a megohmmeter from each Armature lead, and each field lead, to the frame of the motor. Leakage can result in drive failure.

F. ISOLATION TRANSFORMER INSPECTION

1. When an isolation transformer is used, verify the following checks. Be sure to check off each item after completion to insure that no procedure is overlooked.
2. With AC power off, inspect the transformer primary and secondary connections and jumpers to insure tightness.
3. With transformer DISCONNECTED FROM M4000 turn AC power on and verify the input and output voltages are correct.
4. When possible, remove the (X0) neutral from earth ground to assure that the **secondary is isolated from earth ground. Also, corner ground delta-Y connections are discouraged.**

G. GROUND CHECKS

The following ground checks are to be performed with a multimeter. Be sure to check off each item after completion to insure no procedure is overlooked.

CAUTION

Do not use Megger or hi-pot to determine grounds. High voltage present in such instruments will destroy semi-conducting elements.

Use a multimeter.

If a ground exists, locate and eliminate it before proceeding.

NOTE: The logic circuits of the Drive Module are intrinsically isolated from ground. If any circuit is to be grounded intentionally, SECO should be consulted.

Set multimeter on the high ohms scale (x 10K ohms) and check the resistance to ground (chassis of the Controller):

1. Input Terminals L1, L2, and L3
2. Motor Terminals A1, A2, F1, and F2
3. DC control terminals
4. Tachometer terminals (if provided)

H. POWER UP AND VOLTAGE CHECKS

The M4000 is supplied for a particular AC line voltage. Before applying power, make certain that the correct line voltage is available, and verify that it is within $\pm 10\%$ of the drive's requirement.

CAUTION

Operation of the M4000 unit on the incorrect voltage supply will cause damage to equipment and may cause personal injury.

DANGER

Before applying power initially, close the cabinet door to prevent personal injury or death in the event of a catastrophic failure.

Before applying power, make sure that motor armature leads are DISCONNECTED FROM DRIVE and not contacting any part of drive.

144 Start-Up Guidelines

Apply AC power, and verify with meter probes on input terminals L1, L2, and L3, that the following voltages are present:

- 207 VAC to 253 VAC for 230 volt drives.
- 414 VAC to 506 VAC for 460 volt drives.

No phase should vary more than 5% from the others.

When power is applied, the M4000 will go through a self-diagnostic procedure, during which all LED's and numeric displays will blink in sequence.

When finished, the DRIVE READY and ZERO SPEED LED's will illuminate steadily. The PARAMETER INDEX WINDOW WILL read 00. The PARAMETER DATA WINDOW should read 000. **If any of these conditions are not met, DO NOT PROCEED!** Prevent damage to your drive by going to section 7.0 to determine and correct the problem at hand.

I. MOTOR FIELD VOLTAGE

CAUTION

When connecting the motor, pay close attention to the markings on each motor lead. Damage to the M4000 and motor may occur if incorrect connections are made.

The following steps verify that the correct field voltage is being applied:

- 1 - Make sure that motor armature is still DISCONNECTED.
- 2 - Apply AC power and check with voltmeter that the appropriate voltage appears across F1 (+) and F2 (-) terminals:
 - 150 VDC for a 230 VAC drive
 - 300 VDC for a 460 VAC drive

Note: If your unit has been supplied with a special field voltage supply, consult the drawings and supplementary information provided for details.

Consult the Field Set-Up Section of this manual for more details.

J. COOLING FANS-

Drives at 5-20 HP at 460 VAC and 5-10 HP at 230 VAC have no heatsink cooling fans. Drives at 25-40 at 460 VAC and 15-20 HP at 230 VAC have fans that require a 115 VAC 1 ϕ supply. Currently, newer models at 50 HP and above at 460 VAC and 25 HP and above at 230 VAC have a built-in fan supply and no wiring is required. In the case where heatsink cooling fans exist, it is the owner's responsibility to make sure the fans are operating for proper ventilation. Failure to do so may cause equipment damage and will void the warranty! Fans should be energized whenever power is applied to the M4000 unit.

K. POWER MODULE WIRING - LOGIC AND CONTROL

When using a Drive Module only, the following instructions regarding operator device connections must be followed. Pushbuttons and switches should be connected to relay coils, and the relay contacts used to actuate the various functions. Pushbuttons and switches should not be connected directly to the terminals on the Drive Module.

Due to the number of possible combinations of operator device configurations, not all can be depicted. However, examples of common connections are shown in Fig. 2.H, pg 2-11. Choose the correct connections for your unit, depending on whether it is Non-Regenerative or Regenerative.

Start/Stop Logic-

The Drive Module is started by enabling a number of inputs present on the terminal strip TB3 on the MDA-2 Board. Normally this is done by maintained relay contact closure. Interlocking with an Armature Contactor and internal relay contacts is required..

Speed Potentiometer-

A 2K - 10K ohm, 2 Watt industrial grade potentiometer is recommended for use with the M4000 Series Drive. Note that shielded cable is required. To verify that the speed pot is working internally:

1. Apply power to the drive.
2. Display DRIVE STATUS PARAMETER 1.01.
3. Rotate speed pot clockwise and counterclockwise. Parameter data value should change to follow the input signal.

Direction Control-

Regenerative Drive Modules have the capability of solid state reversing. That is, reversing does not require a second Armature Contactor. This function is accessed by connections shown in Figure 2.H, pages 2 - 11.

Analog Outputs-

Simple analog voltmeters may be used to indicate approximate motor speed or load. Figures 2.H show connection points. Note that in a unit NOT run in tach feedback mode, the connection of the speed indicating meter should be made to the ARM FBK terminal. In reversing/regenerative units, the speed signal is bi-polar, that is, positive for forward, negative for reverse. Shielded cable must be used for any meter connections.

For wiring and logic for the chassis or enclosed packaged drive, refer to the User Interface Board Reference Section of this manual.

146 Start-Up Guidelines

L. Motor Rotation

Now that all power supplies and references have been checked, and all initial parameter settings have been verified, it is time to connect and start the motor. Disconnect AC power from the M4000 and connect the Armature wires to the A1 and A2 terminals in the M4000.

CAUTION

Disconnect the motor from the driven machinery for the following steps if machinery can be damaged by reverse rotation!

If a motor-mounted tach generator is to be used, make certain that it is NOT connected at this point. Set the speed potentiometer to zero and apply AC power to the unit. Again, the self-diagnostic sequence is performed by the M4000 and the DRIVE READY and ZERO SPEED LED's should illuminate steadily. Put the drive in FORWARD if applicable, and press the START button. If supplied, the main contactor will close, and the AT SPEED and BRIDGE 1 LED's should illuminate.

Slowly turn the SPEED POTENTIOMETER clockwise. The motor should begin to rotate. The ZERO SPEED LED should extinguish at this point, and the AT SPEED LED will go out briefly, until the motor reaches speed set. Ensure that the direction of rotation is that which was expected. If not, with AC power off, A1 and A2 wires should be interchanged. Take care to correctly connect the motor series field if this is done. Continue to increase speed, but do not exceed the maximum motor rating. Press STOP button. If DYNAMIC BRAKING is present, the motor will come to a rapid stop. If drive is a regenerative type, depending on method used to wire the STOP circuit, motor will either coast to rest or regenerate to a stop, following the deceleration ramp. If drive is regenerative type/reversing unit, check for both directions of rotation.

Note that due to manufacturing tolerances, a motor may not run at nameplate speed when normal armature voltage and field current is supplied to the motor. Most manufactures quote $\pm 7\frac{1}{2}\%$ tolerance on motor speed under normal operating conditions. If the motor will not run at nameplate speed under these conditions, consult SECO applications.

SPECIFICATIONS

A. General

Service Conditions	
AC Line Input	380 to 460 or 200/240 Volts +/-10%, 3 ?
AC Line Input Frequency	48 to 62 Hz
Ambient Temperature	0 ?C to 40 ?C enclosed units, 0 ?C to 55 ?C chassis units
Humidity	5 to 95 % non-condensing
Attitude	To 3300 ft. without derating
Armature Voltage	0-240 VDC or 0-500 VDC
Maximum Load Capacity	150 % for 1 minute
Line Protection	Fuses, M.O.V.s and capacitors
Performance	
Speed Range	50:1, motor and feedback device dependent
Speed Regulation	95% load change
Armature Voltage Feedback	+/- 1 % to +/- 2 % motor dependent
Tach Feedback	+/- 0.1% TO +/- 1 % tach dependent
Encoder Feedback	+/- 0.01 % using 1024 PPR encoder
Resolution	0.025 % with analog input and encoder feedback
Basic Adjustments	
Max. Speed	0 to 100 % of base speed
Min. Speed	0 to Max. Speed
Accel. Time	0 to 200 seconds
Decel Time	0 to 200 seconds
Jog Speed	0 TO 100 % of base speed (separate accel/decel)
Max. Torque Motoring	0-150 %
Max. Torque Regenerating	0-150 %
Analog Inputs	
1 programmable analog input	Scalable 0 to +/- 10 VDC, 0 to 20 mA, 4 to 20 mA, 20 to 4 mA current input selectable, 12 bit resolution, 100 k? input impedance
4 programmable analog inputs	Scalable +/- 0 to 10 VDC. 10 bit resolution
Analog Outputs	
1 Dedicated Meter Output	0 to +6.6 VDC corresponds to 0 to 150 % full load armature current. Output is unipolar absolute value 0 to + 6.6 VDC @ 5 mA DC max. current output capability.
3 Programmable Analog Outputs 0 to +/- 10 VDC scalable output. User programmable to indicate armature voltage, current, speed, tach voltage, field current, etc. @ 5 mA DC max. current output capability each.	

148 Specifications

Digital Inputs	
10 Programmable Digital Inputs	24 VDC pull down to drive common. Low or high level switch selectable active logic inputs. Can be used to control speed/torque switching, Tach/Arm feedback selection and many more useful logic functions. 100 k Ω Input Impedance. Negative or Positive logic dipswitch selectable). Negative logic is the default and should not be changed unless positive logic is absolutely mandatory.
Digital Outputs	
6 User Relays	Programmable to indicate Drive Ready, Drive Fault, Zero Speed, Overload, @ Speed or Motor Running. Relays have Form C contacts rated at 250 VAC, 5 Amps. (Packaged Drives Only)
2 User Relays	One dedicated Drive Ready set of Form C contacts. One undedicated Zero Speed Form C contacts. Form C contacts are rated at 250 VAC / 2.2 Amps, 110 VAC / 5 Amps, 5 VDC / 5 Amps. Note : Fusing and suppression is recommended and must be supplied by the user.
5 Programmable Digital Outputs	Open Collector + 24 VDC at 40 mA DC max. each when used with power unit. One dedicated Drive Ready Relay Form C contact. (Power Unit version).
Selectable Feature	
Select	Speed or Torque Control, Speed Reference 1 or 2, Field Loss Alarm Disable, Standstill Logic (Default settings listed, user programmable)
Diagnostics	
Status Display	9 LED status indicators (labeled and visible from the front of the module) are provided to indicate the following drive conditions : Drive Ready Alarm (drive overloaded) Drive at Zero Speed Run Forward selected Run Reverse selected Bridge 1 enabled Bridge 2 enabled Drive at set speed Current Limit reached
Motor Requirements	
Type	DC Shunt, 240 V Armature / 150 V Field or 500 V Armature / 300 V Field Non-Standard Fields (i.e. 200 VDC, 240 VDC) available as an add-on option

Encoder Requirements	
Type	Incremental 600 pulses per revolution preferred, must be differential output (A, A NOT, B, B NOT). Programmable for 60 to 2048 pulses per revolution, 2 channel quadrature, differential Power Supply, 5V/ 12V / 15V, 300 mA Max. Frequency, 200 kHz
+10 VDC and –10 VDC Supplies	
Current	Short Circuit Proof, +/- 1 % Tolerance, 10 mA max.
+24 VDC Supply	
Current	200 mA max. resistive or inductive loads only !
Drive Enable	
Delay	30 milliseconds between removal of enable signal and inhibit firing (turning off the SCRs)
Stopping Modes	
Types	Coast to Rest DB Stop (Dynamic Braking) Ramp to a Stop Regen to a Stop (on Regen Units Only)
Communications	
Serial Port	RS 485, isolated ANSI 3.28X protocol 9 pin DSUB type connector
Start Initiation	
Types	Manual : By operator controls Remote: By serial communications
Other Features	Current Loop Auto-Tuning, Multi-Level programmable security

150 Specifications

Interface Board Specs	
Power Supplies +/- 10 VDC	
Current	10mA max Reference
Power Supply +24 VDC	
Current	200 mA max
Analog Inputs (1-4)	
Max Parallel Resistance	Must exceed 2k?
Analog Outputs (1-3)	
Voltage and Current Ratings	+/- 10 VDC 5mA max.
Status Outputs	
Max Current	Open Collector max. 100 mA sink
Relay Outputs	
Relay #1, #2	5 A @ 125/250 VAC 30 VDC NO, NC, COM (Common / Pole)

B. Mentor Model Number Nomenclature

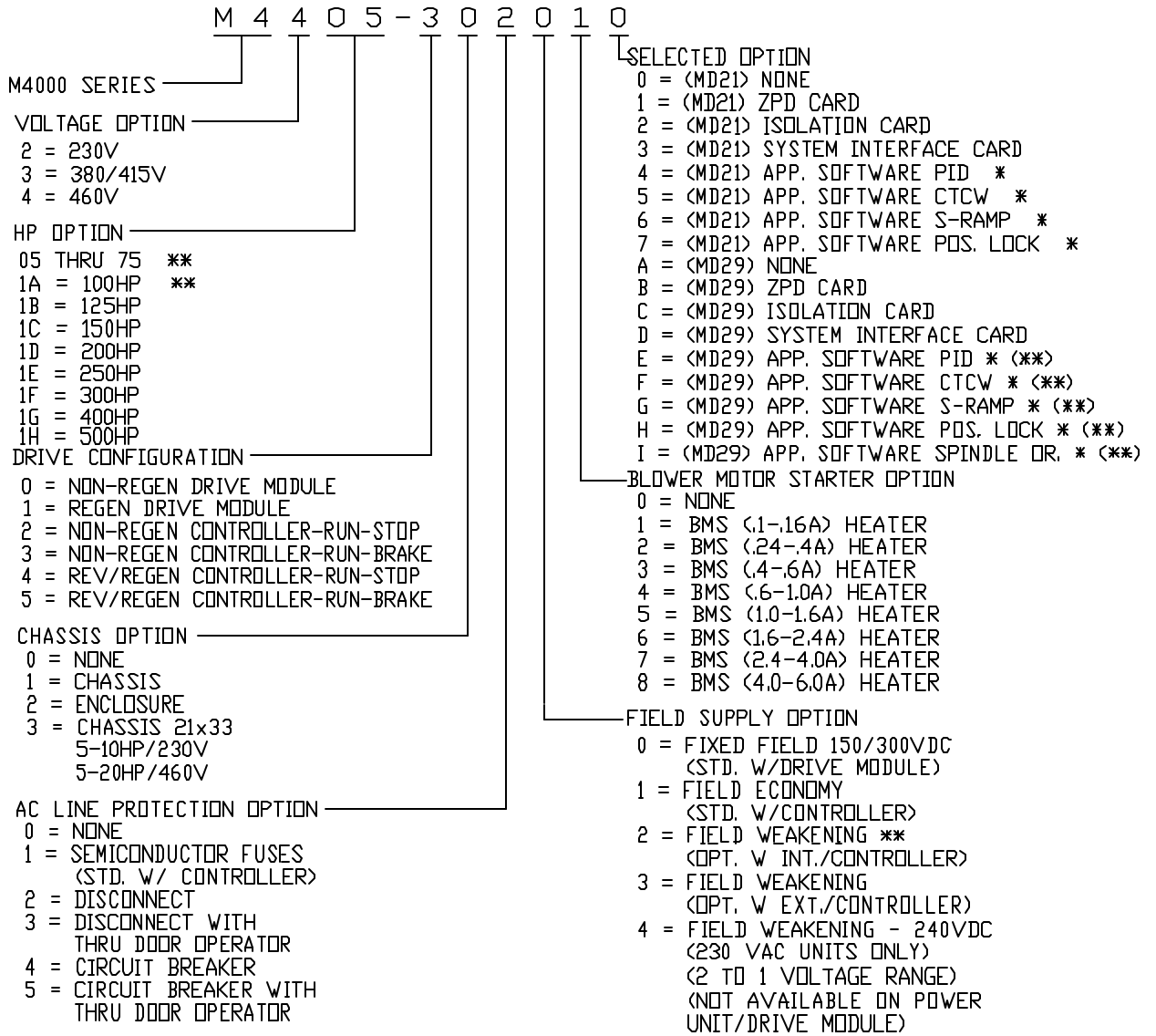

* INCLUDES SYSTEM INTERFACE BOARD CHASSIS OPTION 1,2,3.

** HP USING POWER UNITS 'M45' THROUGH 'M155' USE 'M45-' WITH MDA3' AND SHOW A '2' IN FIELD OPTION.

(**)UNITS WITH MD29 REQUIRE MD2AB USER INTERFACE BOARD.

NOTE: IF ABOVE OPTIONS DO NOT MEET CUSTOMER'S ORDER REQUIREMENTS THEN USE A 'SPECIALS' NUMBER. EXAMPLE: M4405-SXXXX

152 Dimensions

DIMENSIONS

ALL DIMENSIONS SUPPLIED ARE FOR ESTIMATING PURPOSES ONLY. CONTACT DANAHER MOTION FOR CERTIFIED DIMENSIONS.

5-10HP-240VDC / 5-20HP-500VDC

15-20HP-240VDC / 25-40HP-500VDC

POWER UNITS

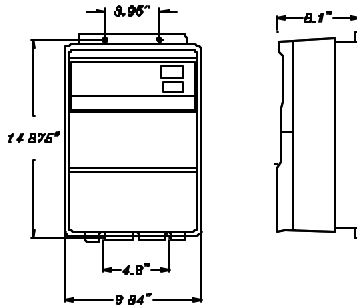

POWER UNITS

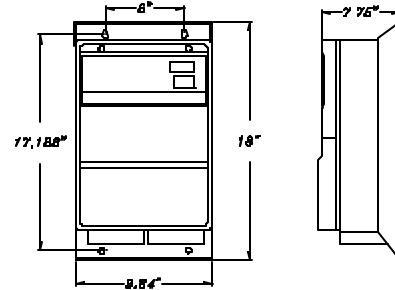

CHASSIS

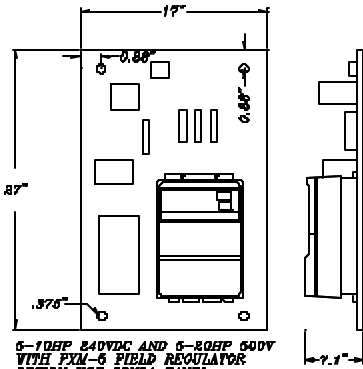

CHASSIS

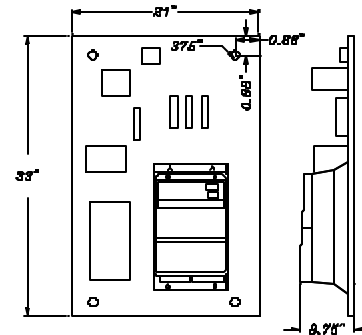

ENCLOSED NEMA 12

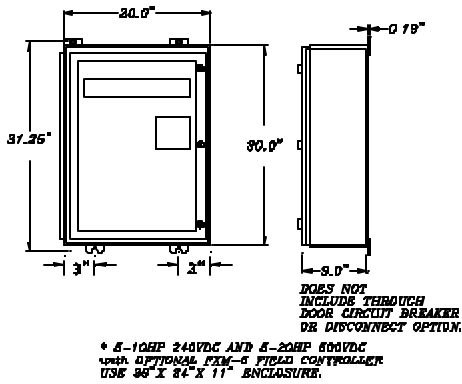

ENCLOSED Ventilated NEMA 12

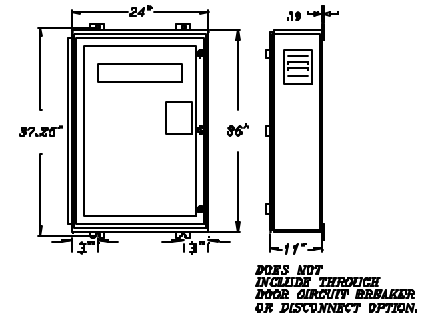

DIMENSIONS

ALL DIMENSIONS SUPPLIED ARE FOR ESTIMATING PURPOSES ONLY. CONTACT DANAHER MOTION FOR CERTIFIED DIMENSIONS.

25-50HP-240VDC / 50-100HP-500VDC

60-100HP-240VDC / 125-200HP-500VDC

POWER UNITS

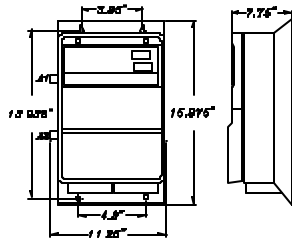

CHASSIS

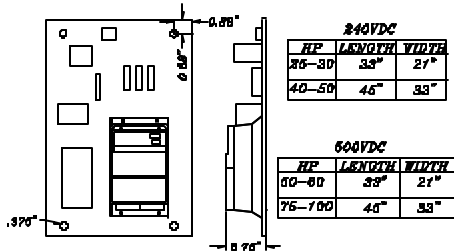

ENCLOSED

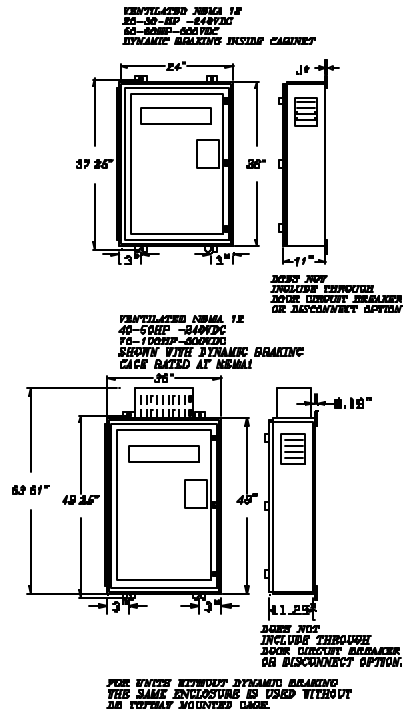

POWER UNITS

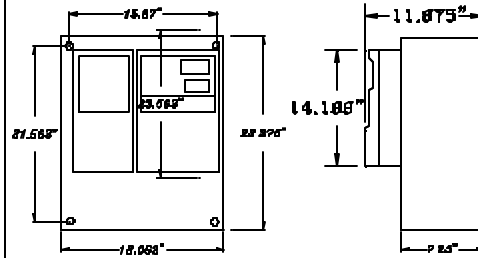

CHASSIS

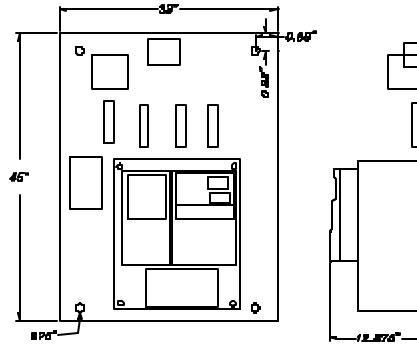

ENCLOSED

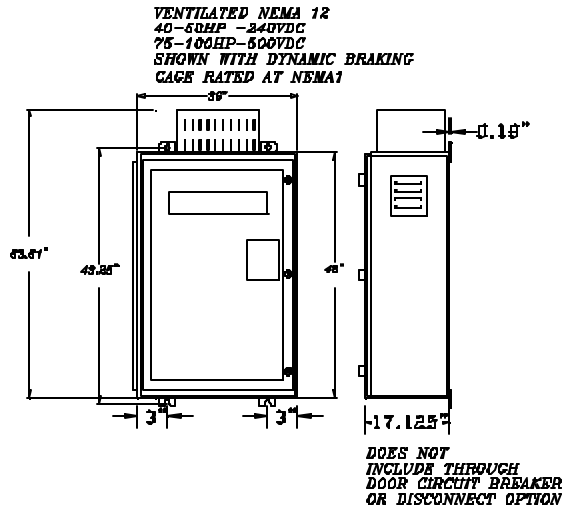

154 Dimensions

DIMENSIONS

ALL DIMENSIONS SUPPLIED ARE FOR ESTIMATING PURPOSES ONLY CONTACT DANAHER MOTION FOR CERTIFIED DIMENSIONS

125-200HP-240VDC / 250-400HP-500VDC

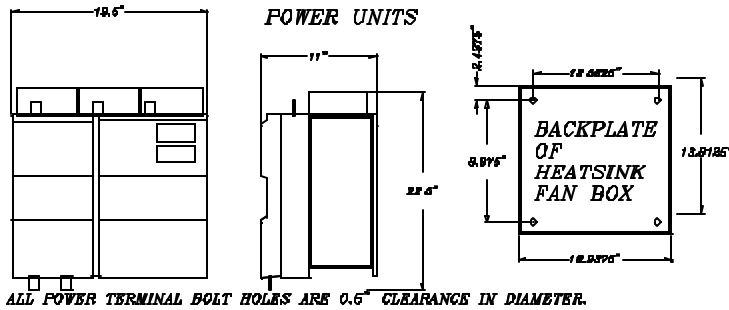

ALL POWER TERMINAL BOLT HOLES ARE 0.6" CLEARANCE IN DIAMETER.

CHASSIS

125-150HP-240VDC / 250-300HP-500VDC
 THE 300HP AT 240VDC AND THE 400HP AT 500VDC
 ARE CUSTOM SIZED CHASSIS PANELS PER REQUEST.

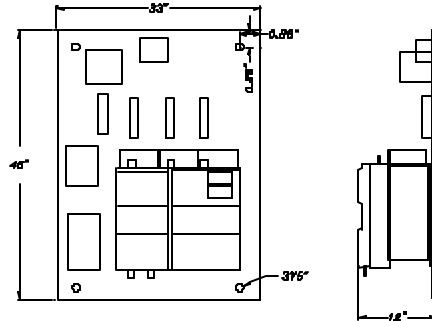

ENCLOSED

VENTILATED NEMA 12
 125-150HP-240VDC
 125-300HP-500VDC
 SHOWN WITH DYNAMIC BRAKING
 CAGE RATED AT NEMA1
 FOR 200HP-240VDC AND 400HP-500VDC CONSULT
 WARNER ELECTRIC FOR DESIRED FREE-STANDING
 ENCLOSURE NEEDS.

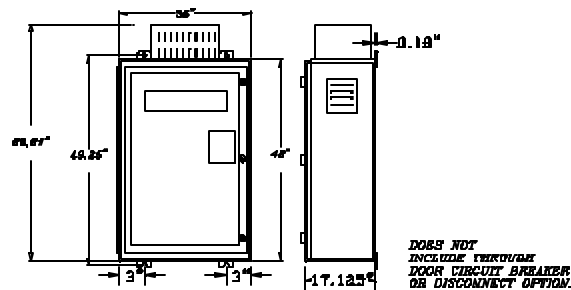

300-600HP-240VDC / 500-1000HP-500VDC

CONSULT DANAHER MOTION ENGINEERED SYSTEMS CENTER
 FOR DIMENSIONING DETAILS. THESE UNITS ARE AVAILABLE
 AND ARE NORMALLY PLACED IN FREE-STANDING ENCLOSURES
 TO MEET THE APPLICATION REQUIREMENTS.

D. Power Module I/O PinoutTB1

<u>Pin</u>	<u>Interface Board Equivalent</u>	<u>Function</u>	<u>Description</u>
1	TB4-4	+10VDC	+10 VDC Supply (normally used for a speed pot, torque pot, etc.). 10 mA max. rating. 2 K ohm minimum equivalent resistance.
2	TB4-5	-10VDC	-10 VDC Supply (normally used for a speed pot, torque pot, etc.). 10 mA max. rating. 2 K ohm minimum equivalent resistance.
3	TB4-7	Speed	Wiper from speed pot or + input from a two wire line speed signal. Raw signal can be viewed in parameter 7.05 where 0 to +/- 1000 = 0 to +/- 10 VDC. Input is directed to parameter 1.17 via destination parameter 7.15. Can be scaled by parameter 7.20.
4	TB4-8	GP1	General Purpose Input 1 serving as a secondary speed reference input (selected by connection of TB3-28 F8 to TB4-40 or TB2-20). Raw signal can be viewed in parameter 7.01 where 0 to +/-1000 = 0 to +/- 10 VDC. Input is directed to parameter 1.19 via destination parameter 7.11. Can be scaled by parameter 7.16.
5	TB4-9	GP2	General Purpose Input 2 serving as the Reference Offset Input. Raw signal can be viewed in parameter 1.04 via destination parameter 7.12. Can be scaled by parameter 7.17.
6	TB4-10	GP3	General Purpose Input 3 serving as the Torque Reference Input. Raw signal can be viewed in parameter 7.03 where 0 to +/- 1000 = 0 to +/- 10 VDC. Input is directed to parameter 4.08 (Torque Reference) via destination parameter 7.13. Used only when in torque mode or torque mode with speed over-ride (selected by connection of TB3-29 F9 to TB4-40 or TB2-20). Can be scaled by parameter 7.18.
7	TB4-11	GP4	General Purpose Input 4 serving as an user programmable input. Raw signal can be viewed in parameter 7.04 where 0 to +/- 1000 = 0 to +/- 10 VDC. Input can be directed to any read/write parameter via destination parameter 7.14. Can be scaled by parameter 7.19.
8	-	Therm	Not used. No function.
9	TB4-1	Tacho-	- Tach Input
10	TB4-2	Tacho+ (0V)	+ Tach Input

156 Specifications

Power Module I/O Pinout

TB2

<u>Pin</u>	<u>Interface Board Equivalent</u>	<u>Function</u>	<u>Description</u>
11	TB4-13	Curr	Dedicated Analog Output representing the Armature Current where 0 to +/- 10 VDC = 0 to 150 %. Armature Current can be viewed in parameter 5.01 (Current Feedback) where 0 to +/- 1000 equals 0 to +/- 150 % Full Load Amps (Drive Nameplate).
12	TB4-14	DAC1	Programmable Analog Output 1 (0 to +/- 10 VDC) representing 0 to +/- 100 % motor speed via Tach Feedback. The analog output is set by source parameter 7.08 (default = 3.02 Tach Feedback) and scaled by parameter 7.21.
13	TB4-15	DAC2	Programmable Analog Output 2 (0 to +/- 10 VDC) representing 0 to +/- 100 % Armature Voltage. The analog output is selected by source parameter 7.09 (default = 3.04 Armature Voltage) and scaled by parameter 7.22.
14	TB4-16	DAC3	Programmable Analog Output 3 (0 to +/- 10 VDC) representing 0 to + 100 % Field Current. The analog output is selected by source parameter 7.10 (default = 6.03 Field Current) and scaled by parameter 7.23.
15	-	ST1	Programmable Status Output (Open Collector). Represents Drive Running and selected by source parameter 9.07 (Default 1.11). Drive Running is defined as : Drive is started and no faults are present.
16	-	ST2	Programmable Status Output 2 (Open Collector). Represents At Speed and selected by source parameter 9.13 (Default 10.07). At Speed is defined as : Motor running at set speed.
17	-	ST3	Programmable Status Output 3 (Open Collector). Represents Overload and selected by source parameter 9.19 (Default 10.13). Overload is defined as : Motor current in timed-overcurrent condition. The timed overcurrent trip will occur if the load isn't reduced.
18	-	ST4	Programmable Status Output 4 (Open Collector). Represents Zero Speed and selected by source parameter 9.21 (Default 10.09). Zero Speed is defined as : Motor at zero speed or within the zero speed window (setable by parameter 3.23 with a range of 0.0 to 25.5 % of maximum speed). Speed is detected by parameter 3.02, Speed Feedback.
19	-	ST5	Programmable Status Output 5 (Open Collector). Represents Fault and selected by source parameter 9.23 (Default 10.12). Fault is defined as : Drive has faulted. See Troubleshooting section of the manual for numerical and mnemonic fault codes.
20	TB4-6, TB4-12, and TB4-18	0V	Analog Common

Power Module I/O Pinout

TB3

<u>Pin</u>	<u>Interface Board Equivalent</u>	<u>Function</u>	<u>Description</u>
21	-	F1 (STOP)	If connected to drive common (TB4-40), the STOP input activates 8.01 (= 1) and the
22	TB2-12	F2 (IR)	If connected to drive common (TB4-40), the Inch Reverse input causes 1.13 (Jog) to set to 1 (active) and parameter 1.12 (Reverse) to set to 1. Drive speed is based on parameter 1.05 (Jog Speed).
23	TB2-13	F3 (IF)	If connected to drive common (TB4-40), the Inch forward input causes 1.13 (Jog) to set to 1 (active). Drive speed is based on parameter 1.05 (Jog Speed).
24	TB2-11	F4 (RR)	If connected to drive common (TB4-40), the Run Reverse input causes parameter 1.12 (Reverse) to set to 1 (active) and parameter 1.11 (Reference "ON") to set to 1.
25	TB2-10	F5 (RF)	If connected to drive common (TB4-40), the Run Forward input causes parameter 1.11 (Reference "ON") to set to 1.
26	TB5-1	F6	Ramp Enable
27	TB5-2	F7	Field Loss Disable
28	TB5-3	F8	Reference Select
29	TB5-4	F9	Torque with Speed Over-ride Mode Select
30	TB5-5	F10	Standstill Logic

TB4

<u>Pin</u>	<u>Interface Board Equivalent</u>	<u>Function</u>	<u>Description</u>
31	-	Enable	Enables parameter 8.11 (Drive Enable) =1 when connected to the analog common (TB4-40). When disconnected, SCR firing is disabled and no armature output will result. If the drive is running when disconnected, the motor will coast to a stop.
32	TB4-17	Reset	Momentary connection resets the drive in the case of a fault.
33	-	+24 VDC	+24 VDC power supply (200 mA max.). Can be used to power a relay for logic purposes.
34	-	POLE	Common of dry contact relay for indication of zero speed. See Specs section of manual for further details.
35	-	NC	Normally Closed contact of dry contact relay for indication of zero speed. See Specs section of manual for further details.
36	-	NO	Normally Open contact of dry contact relay for indication of zero speed. See Specs section of manual for further details.

158 Specifications / User Interface Board

Power Module I/O Pinout

TB4

<u>Pin</u>	<u>Interface Board Equivalent</u>	<u>Function</u>	<u>Description</u>
37	-	POLE	Common of dry contact relay for indication of Drive Ready. Drive Ready is defined as : Drive has 3 phase power and no faults are present. See Specs section of manual for further details.
38	-	NC	Normally Closed contact of dry contact relay for indication of Drive Ready. Drive Ready is defined as : Drive has 3 phase power and no faults are present. See Specs section of manual for further details.
39	-	NO	Normally Open of dry contact relay for indication of Drive Ready. Drive Ready is defined as : Drive has 3 phase power and no faults are present. See Specs section of manual for further details.
40	TB4-6, TB4-12, and TB4-18	OV	Analog Common

The User Interface Board

The M4000 User Interface Board was introduced by Danaher Motion to simplify the installation of a M4000 Series DC Drive. The interface board can be found on chassis or enclosed M4000 packaged drives in three different models:

<u>Model</u>	<u>Description</u>	<u>Part #</u>
Non-Reversing	Found on Non-Regen packaged drives	WB37156-02
Reversing	Found on Regen packaged drives	WB37156-01
Systems	Available as an add-on (supplied loose) for enhanced performance. Will work with either Non-Regen or Regen.	WB37156-00, kit # 4998-00

The advantages of using an user interface board include:

User Interface Board	Power Module
115 VAC run/jog/stop control circuits and pushbuttons can be wired directly to the Interface Board. This significantly increases the allowable distance from operator remotes to the drive cabinet.	Dry contact relays or non-energized pushbuttons must be used (Note : the power module's logic inputs use a sink to common configuration.)
The opening and closing of the Armature Contactor (mounted on the chassis back-plate) is interlocked with the drive's output.	External relay logic and/or PLC is required to control an armature contactor (NOT included with a Power Module).
2 Form C relays (with NO and NC on each) are provided with jumper programmability for external indication of drive status. Note : 4 Form C relays are included on the Systems Interface Board.	Open-Collector Status Outputs require external relay logic for drive status indication.

A. Logic Description Of Interface Board

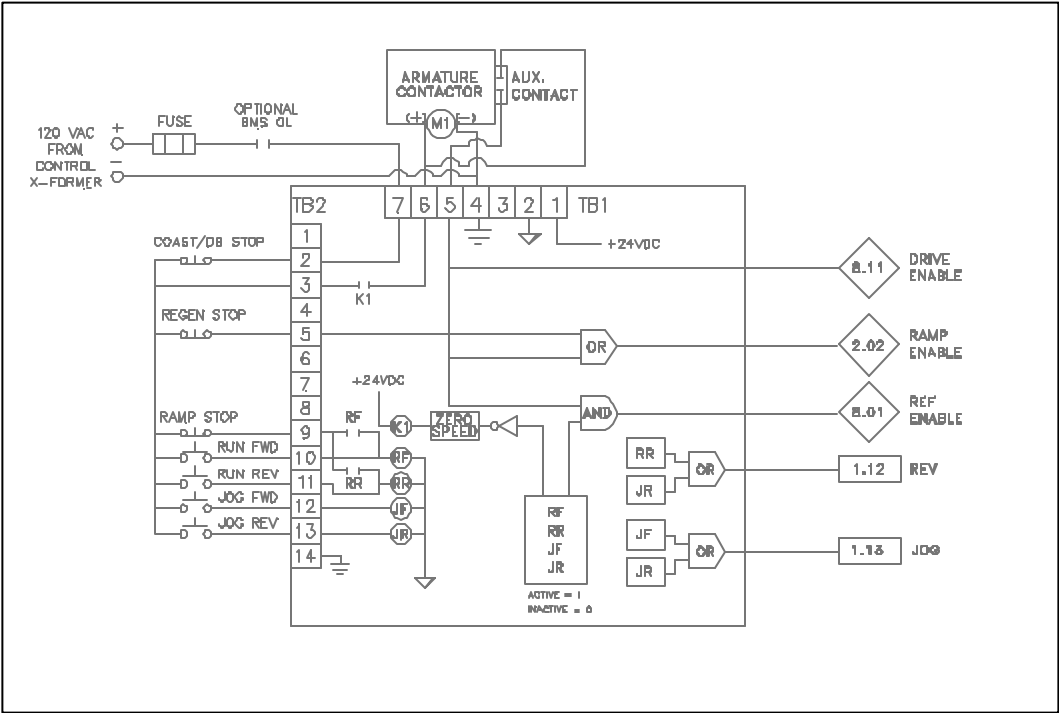

160 User Interface Board

Run/Stop

The run/stop logic when using an interface board is based on the following :

TB2-2 and TB2-3 must be jumpered in order to place 120VAC on one side of the K1 relay. When the run fwd command is issued the not gate output will pull the - side of the K1 relay coil low and +24 VDC will be dropped across the coil and the K1 relay will pull in. This in turn will drop the 120VAC across the armature contactor coil and the armature contactor will pull in. The K2 relay - side will also pull low when the run fwd is issued and the K2 relay will energize. This the seal in.

When the armature contactor pulls in, the aux. contact closes. This causes the enable ramp and enable firing to go low (activate). If the aux. contact is closed and the run fwd relay is still sealed in then the stop circuit is satisfied (P1-21, F1). This causes the enable reference LED to come on. When the stop command is given all of these status' change (or drop out).

Jog

The jog function (inch) operates in a similar fashion to the run command with the exception that there is no seal in relay (i.e. K2). When the jog command is given it pulls the minus side of the K1 relay coil low and the armature contactor pulls in. The enable firing and enable ramp are activated through the aux. contactor (as aforementioned). Also, as long as the jog command is held in (and voltage is present on the input) then the stop circuit (P1-21, F1) is satisfied. One last function to mention is the Jog Contactor Drop Out Delay (J13). This jumper determines whether a delay exists after the jog input has been removed or not. If "on", a delay will occur and the armature contactor will not immediately drop out. This is useful if the operator does a lot of consecutive jogging and will increase the life of the contactor. Otherwise, in the "off" position, the armature contactor will drop out almost immediately.

Zero Speed

The last function worth mentioning is zero speed. It affects the run/stop or jog function in the following way: If you give the command to stop (the K2 relay drops out) AND no jog command is present then the drive decels to zero speed. Once zero speed is detected then the armature contactor will drop out due to the - of the K1 relay becoming high.

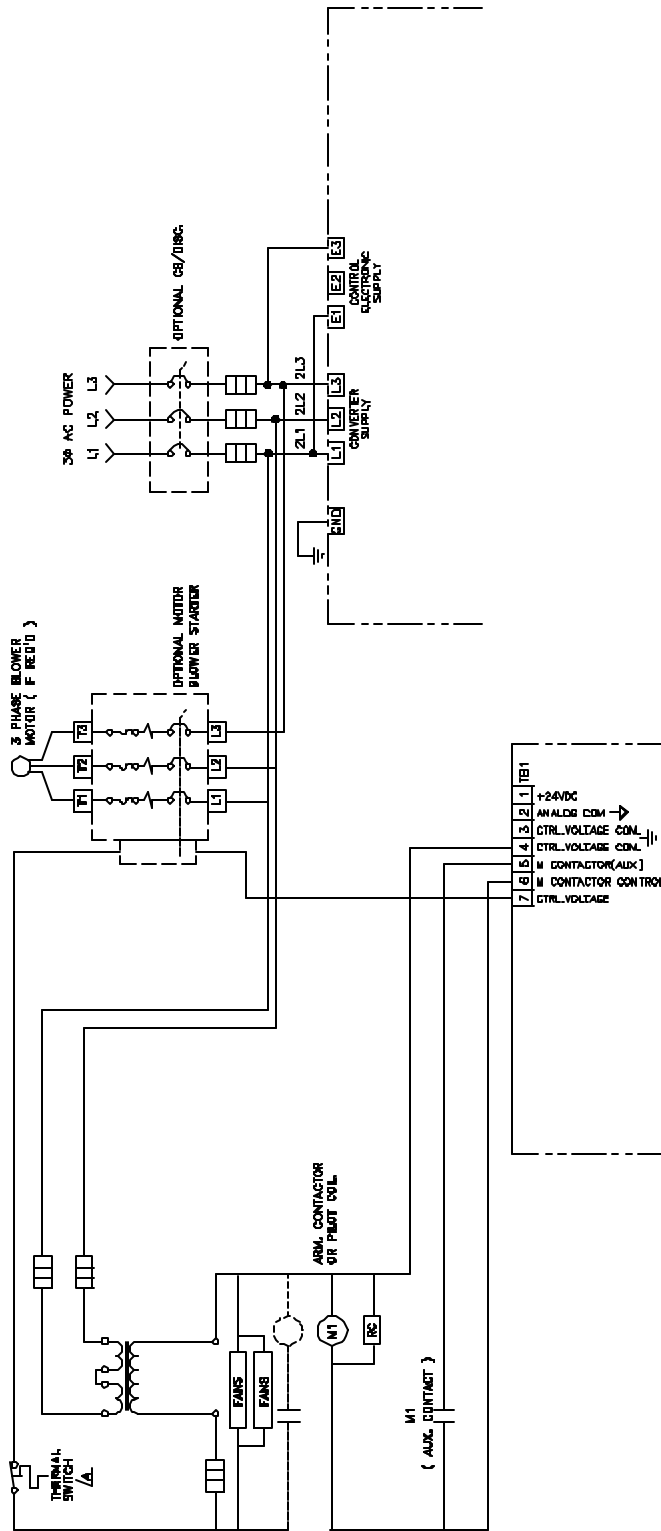

162 User Interface Board

B. Programmable Relay Outputs

As shown below the interface board is shipped preprogrammed with Relay 1 in the Drive Running position and Relay 2 in the At Speed position.

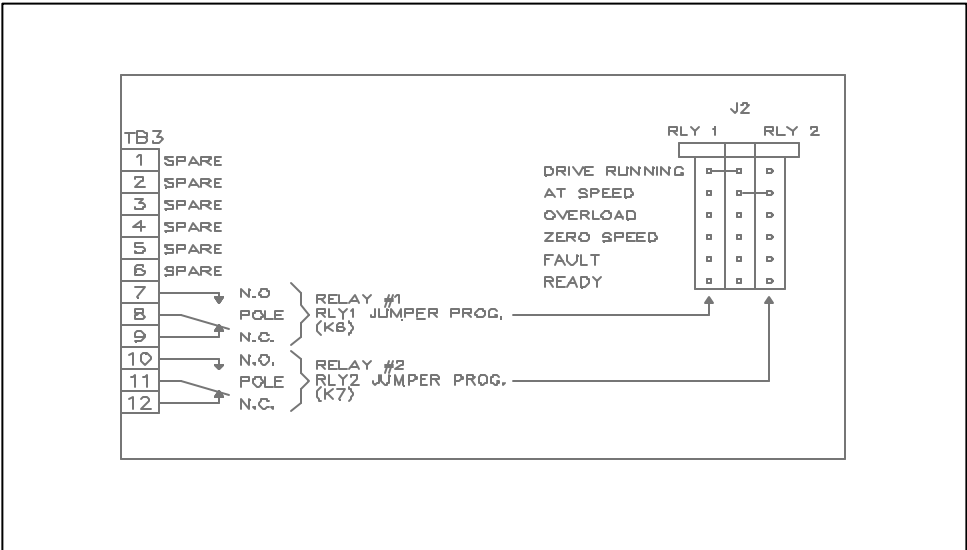

Relay contact ratings are 5 Amps @ 250 VAC or 5 Amps @ 30 VDC resistive load.

J2	Function	Description
1	Drive Running	Drive started and no faults present
2	At Speed	Motor running at set speed
3	Overload	Motor current in timed-overcurrent condition. The Timed Overcurrent Trip will occur if the load isn't reduced.
4	Zero Speed	Motor at Zero Speed or within the Zero Speed Window (settable by parameter #3.23 with a range of 0.0 to 25.5% of maximum speed). Speed is detected by parameter 3.02, Speed Feedback.
5	Fault	Drive has faulted. See Troubleshooting section of manual for numerical and mnemonic fault codes.
6	Ready	Drive has 3 phase AC power and no faults are present.

Relay assignments can be changed to meet your application by changing the source parameter for the corresponding relay. The table below shows the factory settings. For more information, please refer to the Menu 9 Status Outputs Flowchart.

Drive Running	At Speed	Overload	Zero Speed	Fault	Drive Ready
ST1	ST2	ST3	ST4	ST5	
9.07 = 111	9.13 = 1007	9.19 = 1013	9.21 = 1009	9.23 = 1012	Dedicated Controlled by 10.12
9.08 = 1	9.14 = 1	9.20 = 0	9.22 = 0	9.24 = 1	
9.09 = 0	9.15 = 0				
9.10 = 1	9.16 = 1				
9.11 = 1	9.17 = 1				
9.12 = 0	9.18 = 0				

C. Status LED's

<u>LED</u>	<u>Name</u>	<u>Description when " ON "</u>
DS1	Enable Fire	The SCR's (armature output) are enabled and the motor can operate.
DS2	Enable Ref.	The Reference Input is NOT clamped to zero and the line speed signal or speed pot sets the motor speed. See parameter 8.01.
DS3	Enable Ramp	Accel/Decel Ramps are active. If the LED is " OFF ", the drive will Accel/Decel at the rate set by the current limit level. See parameter 2.02.
DS4	Run Fwd	Drive is running in the forward direction.
DS5	Run Rev	Drive is running in the reverse direction.
DS6	Inch Fwd	Drive is either Jogging (no ramp) or Inching (ramp) in the forward direction.
DS7	Inch Rev	Drive is either Jogging (no ramp) or Inching (ramp) in the reverse direction.

164 User Interface Board

D. Interface Board I/O Pin-Out

TB1

<u>Terminal</u>	<u>Description</u>
TB1-1	+24 VDC internal power supply
TB1-2	Signal common of internal power supply
TB1-3	No connection
TB1-4	Isolated 115 VAC common (neutral) from control transformer. Provides the minus side of the armature contactor coil. Note this is the same node as TB2-14.
TB1-5	115 VAC input via auxiliary contact on armature contactor. Provides indication to the drive that the armature contactor is closed and provides the drive enable for armature output (See Parameter 8.11).
TB1-6	115 VAC output to the armature contactor coil. If the K1 relay is energized, the armature contactor closes. If the K1 relay drops out, the armature contactor drops out as well.
TB1-7	115 VAC voltage from control transformer. Note that the TB1-7 and TB2-2 are the same node. This means that if, for example, the control transformer fuse blew, then there would be no control voltage at TB1-7 or TB1-2.

TB2

<u>Terminal</u>	<u>Description</u>
TB2-1	No Connection
TB2-2	115 VAC voltage from control transformer. Note that the TB1-7 and TB2-2 are the same node. This means that if , for example, the control transformer fuse blew, then there would be no control voltage at TB1-7 or TB1-2.
TB2-3	If the 115 VAC control voltage is severed from TB2-3 then the armature contactor will open immediately and the motor will coast to rest or dynamic brake if braking resistors are installed. The drive enable (8.11), the ramp enable (2.02), and the reference enable (8.01) will all go to zero. The corresponding LED's on the interface board will also turn off.
TB2-4	No Connection
TB2-5	If the 115 VAC control voltage is severed from TB2-5 then the ramp enable (2.02) is set to zero (disabled, no ramp) and the drive will regen to a stop. This means the motor will decelerate to zero speed with the maximum amount of braking torque applied. Note that this is valid for Reversing/Regenerative drives only and that the amount of braking torque available is set by the current limit parameters (4.05 and 4.06).
TB2-6	No Connection
TB2-7	No Connection

Interface Board I/O
Pin-Out

TB2

TB2-8	No Connection
TB2-9	If the 115 VAC control voltage is severed from TB2-9 then the drive will decelerate to zero speed based on the decel rates programmed. At zero speed, the K1 relay will open and the armature contactor will drop out. On non-regenerative drives, the decel ramp rate must be equal to or longer than the coast to rest time. Since a non-regen drive has no braking capability, the time to decel to a stop will depend on machine inertia and friction. Note that TB2-9 provides the seal-in for a momentary run fwd or run rev command.
TB2-10	Momentary 115 VAC input initiates a run forward command.
TB2-11	Momentary 115 VAC input initiates a run reverse command.
TB2-12	115 VAC input initiates a jog/inch command in the forward direction. Note that this input does NOT seal-in. Removing the 115 VAC input causes the drive to decel to zero and stop. The primary difference between jog and inch mode is the jog mode has a ramp enable and the inch mode disables the ramp. Jumper J13 sets the time delay between removal of the 115 VAC input to TB2-12 and the dropping out of the armature contactor. In the " OFF" position the time is less than 1 second. In the "ON" position, the time is several seconds. Note if the drive is in the Run Mode, this input will override the normal speed reference and will use the jog reference (parameter 1.05). Once the input is removed, the drive will return to the Run Mode.
TB2-13	115 VAC input initiates a jog/inch command in the reverse direction. Note that this input does NOT seal-in. Removing the 115 VAC input causes the drive to decel to zero and stop. The primary difference between jog and inch mode is the jog mode has a ramp enable and the inch mode disables the ramp. Jumper J13 sets the time delay between removal of the 115 VAC input to TB2-13 and the dropping out of the armature contactor. In the " OFF" position the time is less than 1 second. In the "ON" position, the time is several seconds. Note if the drive is in the Run Mode, this input will override the normal speed reference and will use the jog reference (parameter 1.05). Once the input is removed, the drive will return to the Run Mode.
TB2-14	Isolated 115 VAC common (neutral) from control transformer. Note this is the same node as TB1-4.

166 User Interface Board

Interface Board I/O Pin-Out

TB3

<u>Terminal</u>	<u>Description</u>
TB3-1	No Connection
TB3-2	No Connection
TB3-3	No Connection
TB3-4	No Connection
TB3-5	No Connection
TB3-6	No Connection
TB3-7	Normally Open Contact (Relay #1)
TB3-8	Relay 1 Common
TB3-9	Normally Closed Contact (Relay #1)
TB3-10	Normally Open Contact (Relay # 2)
TB3-11	Relay 2 Common
TB3-12	Normally Closed Contact (Relay # 2)

TB4

<u>Terminal</u>	<u>Description</u>
TB4-1	- Tach Input
TB4-2	+Tach Input
TB4-3	Shield
TB4-4	+10 VDC Supply (normally used for a speed pot, torque pot, etc.). 10 mA max. rating. 2 K ohm minimum equivalent resistance.
TB4-5	-10 VDC Supply (normally used for a speed pot, torque pot, etc). 10 mA max. rating. 2 K ohm minimum equivalent resistance.
TB4-6	Analog common (normally used for a unipolar speed or torque pot, or the – input for a two wire line speed signal).
TB4-7	Wiper from speed pot or + input from a two wire line speed signal. Raw signal can be viewed in parameter 7.05 where 0 to +/- 1000 = 0 to +/- 10 VDC. Input is directed to parameter 1.17 via destination parameter 7.15. Can be scaled by parameter 7.20.
TB4-8	Secondary speed reference input (selected by connection of TB5-3 to TB5-6 of interface board). Raw signal can be viewed in parameter 7.01 where 0 to +/- 1000 = 0 to +/- 10 VDC. Input is directed to parameter 1.19 via destination parameter 7.11. Can be scaled by parameter 7.16.
TB4-9	Reference Offset Input. Raw signal can be viewed in parameter 7.02 where 0 to +/- 1000 = 0 to +/- 10 VDC. Input is directed to parameter 1.04 via destination parameter 7.12. Can be scaled by parameter 7.17.
TB4-10	Torque Reference Input. Raw signal can be viewed in parameter 7.03 where 0 to +/- 1000 = 0 to +/- 10 VDC. Input is directed to parameter 4.08 via destination parameter 7.13. Used only when in torque mode (selected by connection of TB5-4 and TB5-6). Can be scaled by parameter 7.18

Interface Board I/O
Pin-Out

TB4

<u>Terminal</u>	<u>Description</u>
TB4-11	User Programmable Analog Input. Can be viewed in parameter 7.04 where 0 to +/- 1000 = 0 to +/- 10 VDC. Input can be directed to any read/write parameter via destination parameter 7.14. Can be scaled by parameter 7.19.
TB4-12	Analog Common
TB4-13	Dedicated Analog Output representing Armature Current where 0 to +/- 10 VDC = 0 – 150 %. Armature Current can be viewed in parameter 5.01 Current Feedback where 0- +/- 1000 equals 0 to +/- 150 % Full Load Amps (Drive Nameplate).
TB4-14	Programmable Analog Output 0 to +/- 10 VDC representing Tach Feedback where 0 to +/- 100 % motor speed. The analog output is set by parameter 7.08 (default = 3.02 Tach Feedback) and scaled by parameter 7.21.
TB4-15	Programmable Analog Output 0 to +/- 10 VDC representing Armature Voltage where 0 to +/- 100 % armature voltage. The analog output is set by parameter 7.09 (default = 3.04 Armature Voltage) and scaled by parameter 7.22.
TB4-16	Programmable Analog Output 0 to +/- 10 VDC representing Field Current where 0 to +/- 100 % Field Current. The analog output is set by parameter 7.10 (default = 6.03 Field Current) and scaled by parameter 7.23.
TB4-17	Reset. Momentary connection to common resets the drive in the case of a fault.
TB4-18	Analog Common.

TB5

<u>Terminal</u>	<u>Description</u>
TB3-1	Ramp Enable.
TB3-2	Field Loss Disable.
TB3-3	Reference Select.
TB3-4	Torque Mode.
TB3-5	Standstill Logic.
TB3-6	Digital Common.

168 Spare Parts

SPARE PARTS - CIRCUIT BREAKERS AND LINE FUSES

HP 460/230 VAC	DC FLA	AC FLA	CIRCUIT BREAKERS			FUSES		
			AMPS	460V PART #	230V PART #	FUSE SIZE AMPS	VENDOR TYPE	PART #
5/-	8.5	7.0	60	ASW4054-05	-	40		PFU2048-00
7.5/-	13.5	11.3	60	ASW4054-05	-	40		PFU2048-00
10/5	18.0	14.6	60	ASW4054-05	ASW4054-03	40		PFU2048-00
15/7.5	27.2	22.0	60	ASW4054-05	ASW4054-03	40		PFU2048-00
20/10	37.8	31.0	60	ASW4054-05	ASW4054-03	40		PFU2048-00
25/-	42.6	35.0	70	ASW4054-19	-	70		PFU2048-15
30/15	55.4	45.0	70	ASW4054-19	ASW4054-18	70		PFU2048-15
40/20	72.1	59.0	70	ASW4054-19	ASW4054-18	70		PFU2048-15
50/25	90.0	73.0	100	ASW4054-06	ASW4054-04	100		PFU2048-01
60/30	105.0	86.0	100	ASW4054-06	ASW4054-04	100		PFU2048-01
75/40	141.0	115.0	225	ASW4054-07	ASW4054-07	175		PFU2048-03
100/50	173.0	141.0	225	ASW4054-07	ASW4054-07	175		PFU2048-03
125/60	208.0	169.0	225	ASW4054-07	ASW4054-07	250		PFU2048-04
150/75	256.0	208.0	225	ASW4054-07	ASW4057-07	250		PFU2048-04
200/100	341.0	278.0	400	ASW4054-08	ASW4054-09	350		PFU2048-02
250/125	420.0	342.0	400	ASW4054-08	ASW4054-09	400		PFU2048-05
300/150	504.0	411.0	600	ASW4054-20	ASW4054-20	600		PFU2048-26
400/200	672.0	548.0	800	ASW4054-22	ASW4054-22	800		PFU2048-28
500/250	840.0	685.0	800	ASW4054-22	ASW4054-22	800		PFU2048-28

ARMATURE CONTACTORS AND FUSES

(CONTACTORS APPLY TO BOTH REGEN AND NON-REGEN AND ARMATURE FUSES APPLY TO REGEN MODELS ONLY)

HP 460/230 VAC	DC FLA	AC FLA	DC ARMATURE CONTACTORS		FUSES			
					500VDC ARMATURE		240VDC ARMATURE	
			AMP S	PART NUMBER	FUSE SIZE AMPS	PART #	FUSE SIZE AMPS	PART #
5/-	8.5	7.0	40	ARE4017-14	50	PFU2049-00	50	PFU2048-13
7.5/-	13.5	11.3	40	ARE4017-14	50	PFU2049-00	50	PFU2048-13
10/5	18.0	14.6	40	ARE4017-14	50	PFU2049-00	50	PFU2048-13
15/7.5	27.2	22.0	40	ARE4017-14	50	PFU2049-00	50	PFU2048-13
20/10	37.8	31.0	40	ARE4017-14	50	PFU2049-00	50	PFU2048-13
25/-	42.6	35.0	75	ARE4017-15	90	PFU2049-17	90	PFU2048-17
30/15	55.4	45.0	75	ARE4017-15	90	PFU2049-17	90	PFU2048-17
40/20	72.1	59.0	75	ARE4017-15	90	PFU2049-17	90	PFU2048-17
50/25	90.0	73.0	110	ARE4017-16	125	PFU2049-01	125	PFU2048-06
60/30	105.0	86.0	110	ARE4017-16	125	PFU2049-01	125	PFU2048-06
75/40	141.0	115.0	180	ARE4017-17	250	PFU2049-02	250	PFU2048-04
100/50	173.0	141.0	180	ARE4017-17	250	PFU2049-02	250	PFU2048-04
125/60	208.0	169.0	280	ARE4017-18	350	PFU2049-03	350	PFU2048-02
150/75	256.0	208.0	280	ARE4017-18	350	PFU2049-03	350	PFU2048-02
200/100	341.0	278.0	360	ARE4017-19	400	PFU2049-04	400	PFU2048-05
250/125	420.0	342.0	535	ARE4017-20	500	PFU2049-05	500	PFU2048-24
300/150	504.0	411.0	650	ARE4017-45	600	PFU2049-26	600	PFU2048-26
400/200	672.0	548.0	800	ARE4017-46	800	PFU2049-28	800	PFU2048-28
500/250	840.0	685.0	960	ARE4017-47	1000	PFU2049-30	1000	PFU2048-30

170 Spare Parts

BURDEN RESISTORS

460 VAC DRIVES

HP	R TOTAL	R1		R2		R3	
	(OHMS)	PART #	VAL	PART #	VAL	PART #	VAL
5	29.4	PRE1029-145	29.4	-	-	-	-
7.5	20.5	PRE1029-130	20.5	-	-	-	-
10	15.8	PRE1029-119	15.8	-	-	-	-
15	10.7	PRE1029-103	10.7	-	-	-	-
20	7.42	PRE1029-119	15.8	PRE1029-114	14	-	-
25	6.19	PRE1029-116	14.7	PRE1029-103	10.7	-	-
30	5.28	PRE1029-116	14.7	PRE1055-23	8.25	-	-
40	4.13	PRE1055-23	8.25	PRE1055-23	8.25	-	-
50	3.16	PRE1029-116	14.7	PRE1055-19	4.02	-	-
60	2.73	PRE1029-145	29.4	PRE1055-18	3.01	-	-
75	2.15	PRE1029-130	20.5	PRE1029-107	11.8	PRE1055-18	3.01
100	1.67	PRE1055-23	8.25	PRE1055-22	6.81	PRE1055-18	3.01
125	5.19	PRE1029-114	14	PRE1055-23	8.25	-	-
150	4.45	PRE1029-119	15.8	PRE1029-116	14.7	PRE1029-103	10.7
200	3.29	PRE1029-119	15.8	PRE1029-103	10.7	PRE1055-22	6.81
250	2.66	PRE1029-145	29.4	PRE1029-103	10.7	PRE1055-19	4.02
300	2.23	PRE1029-130	20.5	PRE1029-116	14.7	PRE1055-18	3.01
400	1.69	PRE1029-103	10.7	PRE1055-19	4.02	PRE1055-19	4.02
500	1.37	PRE1029-116	14.7	PRE1055-18	3.01	PRE1055-18	3.01

230 VAC DRIVES

HP	R TOTAL	R1		R2		R3	
	(OHMS)	PART #	VAL	PART #	VAL	PART #	VAL
5	14.7	PRE1029-116	14.7	-	-	-	-
7.5	9.8	PRE1029-145	29.4	PRE1029-116	14.7	-	-
10	7.17	PRE1029-116	14.7	PRE1029-114	14	-	-
15	4.86	PRE1029-107	11.8	PRE1055-23	8.25	-	-
20	3.73	PRE1055-23	8.25	PRE1055-22	6.81	-	-
25	2.92	PRE1029-103	10.7	PRE1055-19	4.02	-	-
30	2.5	PRE1029-116	14.7	PRE1055-18	3.01	-	-
40	1.91	PRE1029-114	14.0	PRE1055-23	8.25	PRE1055-18	3.01
50	1.51	PRE1055-18	3.01	PRE1055-18	3.01	-	-
60	5.19	PRE1029-114	14	PRE1055-23	8.25	-	-
75	4.13	PRE1055-23	8.25	PRE1055-23	8.25	-	-
100	3.08	PRE1029-107	11.8	PRE1029-103	10.7	PRE1055-22	6.81
125	2.5	PRE1029-116	14.7	PRE1055-18	3.01	-	-
150	2.11	PRE1029-130	20.5	PRE1029-103	10.7	PRE1055-18	3.01
200	1.59	PRE1029-130	20.5	PRE1055-19	4.02	PRE1055-18	3.01
250	1.27	PRE1055-23	8.25	PRE1055-18	3.01	PRE1055-18	3.01

The table below shows groups of HP ranges where the drive can be re-burdened using the burden resistor values from the previous page. Example: A drive was purchased at 5 HP / 230 V but the motor available requires a 20 HP / 460 V (500 VDC armature). Using the table below, the drive purchased can be changed to a 5, 7.5, or 10 HP at 230 V or be changed to a 5, 7.5, 10, 15, or 20 HP drive at 460 V. However, if a 50 HP, 230 V unit is to be changed, the table below shows the only available option is to change it to a 100 HP 460 V unit.

230 V	460 V
-	5
-	7.5
5	10
7.5	15
10	20
-	25
15	30
20	40
25	50
30	60
40	75
50	100
60	125
75	150
-	175
100	200
125	250
150	300
200	400
250	500

Note: If a unit is changed from 460 V to 230 V or vice versa, make sure that parameter 3.15 (Max. Armature Voltage) is set to the correct motor nameplate voltage (i.e. 240 or 500).

172 Spare Parts

DYNAMIC BRAKING RESISTORS

<u>HP</u> <u>460/230V</u> <u>AC</u>	<u>DC</u> <u>FLA</u>	<u>AC</u> <u>FLA</u>	<u>RESISTORS</u>					
			<u>500VDC ARMATURE</u>			<u>240VDC ARMATURE</u>		
			<u>VAL (OHMS) /</u> <u>WATTS</u>	<u>PART #</u>	<u>QTY</u>	<u>TOTAL</u> <u>EQUIVALENT</u> <u>VAL (OHMS)</u> <u>/ WATTS</u>	<u>PART #</u>	<u>QTY</u>
5/-	8.5	7.0	36/300	PRE2011-05	1	-	-	-
7.5/-	13.5	11.3	24/300	PRE2011-06	1	-	-	-
10/5	18.0	14.6	18/300	PRE2011-07	1	8/300	PRE2011-08	1
15/7.5	27.2	22.0	12/600	PRE2011-06	2	5/300	PRE2011-09	1
20/10	37.8	31.0	9/600	PRE2011-07	2	4/300	PRE2011-10	1
25/-	42.6	35.0	7/500	PRE2011-01	1	-	-	-
30/15	55.4	45.0	6/1000	PRE2011-12	2	2/600	PRE2011-10	2
40/20	72.1	59.0	4.5/1000	PRE2011-11	2	1.6/500	PRE2011-13	1
50/25	90.0	73.0	4.5/1000	PRE2011-11	2	1.6/500	PRE2011-13	1
60/30	105.0	86.0	3.5/1000	PRE2011-01	2	1.2/1000	PRE2011-14	2
75/40	141.0	115.0	2.4/3000	PRE2007-12	2	1.2/1500	PRE2007-12	1
100/50	173.0	141.0	2.0/4000	PRE2007-14	2	0.9/1500	PRE2007-11	1
125/60	208.0	169.0	1.5/6000	PRE2007-13	4	0.9/1500	PRE2007-11	1
150/75	256.0	208.0	1.5/6000	PRE2007-13	4	0.6/3000	PRE2007-12	2
200/100	341.0	278.0	1.0/8000	PRE2007-14	4	0.45/3000	PRE2007-11	2
250/125	420.0	342.0	1.0/8000	PRE2007-14	4	0.36/4300	PRE2007-09	4
300/150	504.0	411.0	0.67/12000	PRE2007-14	6	0.32/5000	PRE2007-09	5
400/200	672.0	548.0	0.571/14000	PRE2007-14	7	-	-	-
500/250	840.0	685.0	0.44/18000	PRE2007-14	9	0.18/9000	PRE2007-09	7

CONTROL TRANSFORMERS AND FUSES

HP 460/230 VAC	DC FLA	AC FLA	CONTROL TRANSFORMER		FUSES FOR CONTROL TRANSFORMER		
					PRIMARY		SECONDARY
					460VAC	230VAC	
			VA	PART NUMBER	PART #	PART #	PART #
5/-	8.5	7.0	100	PTR1021-00	PFU1020-00	PFU1020-00	PFU1006-01
7.5/-	13.5	11.3	100	PTR1021-00	PFU1020-00	PFU1020-00	PFU1006-01
10/5	18.0	14.6	100	PTR1021-00	PFU1020-00	PFU1020-00	PFU1006-01
15/7.5	27.2	22.0	100	PTR1021-00	PFU1020-00	PFU1020-00	PFU1006-01
20/10	37.8	31.0	100	PTR1021-00	PFU1020-00	PFU1020-00	PFU1006-01
25/-	42.6	35.0	100	PTR1021-00	PFU1020-00	PFU1020-00	PFU1006-01
30/15	55.4	45.0	100	PTR1021-00	PFU1020-00	PFU1020-00	PFU1006-01
40/20	72.1	59.0	100	PTR1021-00	PFU1020-00	PFU1020-00	PFU1006-01
50/25	90.0	73.0	100	PTR1021-00	PFU1020-00	PFU1020-00	PFU1006-01
60/30	105.0	86.0	100	PTR1021-00	PFU1020-00	PFU1020-00	PFU1006-01
75/40	141.0	115.0	150	PTR1021-01	PFU1020-00	PFU1020-01	PFU1006-14
100/50	173.0	141.0	150	PTR1021-01	PFU1020-00	PFU1020-01	PFU1006-14
125/60	208.0	169.0	250	PTR1021-02	PFU1020-00	PFU1020-02	PFU1006-15
150/75	256.0	208.0	250	PTR1021-02	PFU1020-00	PFU1020-02	PFU1006-15
200/100	341.0	278.0	500	PTR1021-03	PFU1020-02	PFU1020-05	PFU1006-05
250/125	420.0	342.0	500	PTR1021-03	PFU1020-02	PFU1020-05	PFU1006-05
300/150	504.0	411.0	1000	PTR1021-05	PFU1020-05	PFU1020-06	PFU1006-06
400/200	672.0	548.0	1000	PTR1021-05	PFU1020-05	PFU1020-06	PFU1006-06
500/250	840.0	685.0	1000	PTR1021-05	PFU1020-05	PFU1020-06	PFU1006-06

174 Spare Parts

HEATING AND COOLING INFORMATION

<u>HP</u> <u>460/230VA</u> <u>C</u>	<u>DC</u> <u>FLA</u>	<u>AC</u> <u>FLA</u>	<u>HEATLOSS</u> <u>(WATTS)</u>	<u>COOLING</u> <u>METHOD</u>	<u>AIR FLOW</u> <u>CFM</u>
5/-	8.5	7.0	77	NATURAL CONVECTION	-
7.5/-	13.5	11.3	86	NATURAL CONVECTION	-
10/5	18.0	14.6	96	NATURAL CONVECTION	-
15/7.5	27.2	22.0	115	NATURAL CONVECTION	-
20/10	37.8	31.0	123	NATURAL CONVECTION	-
25/-	42.6	35.0	158	BUILT-IN FAN	72
30/15	55.4	45.0	179	BUILT-IN FAN	72
40/20	72.1	59.0	211	BUILT-IN FAN	72
50/25	90.0	73.0	257	BUILT-IN FAN	72
60/30	105.0	86.0	387	BUILT-IN FAN	72
75/40	141.0	115.0	448	BUILT-IN FAN	72
100/50	173.0	141.0	552	BUILT-IN FAN	72
125/60	208.0	169.0	655	BUILT-IN FAN	318
150/75	256.0	208.0	758	BUILT-IN FAN	318
200/100	341.0	278.0	968	BUILT-IN FAN	680
250/125	420.0	342.0	1216	BUILT-IN FAN	680
300/150	504.0	411.0	1400	BUILT-IN FAN	680
400/200	672.0	548.0	1743	BUILT-IN FAN	680
500/250	840.0	685.0	2084	BUILT-IN FAN	

TROUBLESHOOTING

A. General

INTRODUCTION

The M4000 has a number of diagnostic features that help to identify the source of most common problems. In this section, effective steps toward diagnosis and repair will be outlined.

DANGER

The start-up, calibration, and servicing of this equipment should be performed only by personnel familiar with electronic equipment, the equipment in this drive system, related machinery, and the potential hazards involved. Failure to observe this warning can result in serious personal injury or death, and/or equipment damage.

SAFETY PROCEDURES

Certain basic safety procedures must always be practiced when troubleshooting electronic motor controls and related equipment.

DANGER

Observe the safety procedures listed here, the NEC recommendations, local practices, and plant rules when working on this equipment. Failure to follow these procedures may cause serious personal injury, death, and/or equipment damage.

Do not assume that the procedures listed here form a complete safety list; they are only a basic starting point.

FAULT FINDING

General troubleshooting areas that can be categorized into the following groups:

- ? Loose connections
- ? Wiring errors
- ? Incoming AC line problems
- ? Motor problems
- ? Drive malfunctions

Loose Connections

Some industrial applications generate vibrations that eventually cause connections to become loose. With power removed at the main machine disconnect switch, check and tighten all electrical connections, such as mounting screws or terminal board screws. Also, be sure that all relays and fuse are properly seated in their respective sockets and brackets.

176 Troubleshooting

Wiring Errors

The most common problem in a DC drive's operation is incorrect wiring within a system. Before doing tests or replacements, spend some time examining the wiring. (Keep in mind that a loose or grounded wire can occur in a drive that had previously been operating correctly.)

Incoming AC Power

The following are typical problems located in the incoming AC line:

- ? AC line voltage is not within $\pm 10\%$ range of the nameplate rating of the drive.
- ? AC line voltage is incorrectly matched for the specific drive.

Motor Checks

CAUTION

Do not use a Megger to check for grounds unless the motor wiring to the Controller is completely disconnected. Damage to the circuitry will result if this procedure is not followed.

- ? Field. Check the field windings for open or short circuits.
- ? Armature. Check continuity through the armature and brushes. Use the A1/A2 conductors at the Controller terminals.
- ? Brushes. When replacing worn brushes, use parts **identical** to original equipment. Excessively worn brushes cause a loss of spring tension and subsequent malfunction.
- ? Commutator. Inspect the condition of the commutator. A shiny and light brown surface generally indicates good condition. If oil, grease or other foreign matter is noted, clean thoroughly. Brush carbon is to be removed with a commutator stone. **Do not** use any other type of abrasive.
- ? Bearings and Gear box. Inspect these two areas for proper lubricant levels. (Refer to the manufacturer's recommendations for type and frequency.)
- ? Tachometer. Inspect this unit's mounting bolts for firmness. Inspect the coupling for cracks or excessive wear due to improper alignment and/or excessive motor shaft end play.
- ? Mounting, coupling. Inspect mounting hardware for tightness. The coupling between the motor and the load should be checked for alignment and physical condition.

- ? Cooling. Inspect the motor housing ventilation openings. They should be clean and without dust or dirt.
- ? Fan-cooled types. Inspect the fan and shroud condition. Make sure that the openings are clean and cleared to allow maximum air circulation across the motor case. The motor housing must be kept free of dust, dirt, oil, grease and other matter which causes poor transfer of heat.
- ? Filters. Verify that filters, if used, are clean and able to allow the passage of air. Replace or clean them on a frequent schedule. (The location of the motor and general environment will dictate the need.)

B. DRIVE TROUBLESHOOTING

If none of the sections above helped to solve the problem, identify the symptom. Follow the action listed for each symptom. If parts replacement is required, consult Seco Electronics for further details.

Symptom	Possible Solution(s)
Drive Ready and Zero Speed LED " ON ". On run command, armature contactor closes but drive doesn't run.	Looking at Menu 1 Flowchart, check parameter 1.01 for a value (0-1000). If 1.01 is 0 then check parameter 7.05 for a value and use a voltmeter to check the input between TB4-7 and TB4-12 on the interface board or TB1-3 and TB1-10 on the power module.
	If 1.01 has a positive value then check 1.02 and 1.03 for the same value. If 1.03 =0 then check 8.01. If 8.01 does NOT equal 1 then the stop circuit is not made. If 8.01 = 1 then check 1.16 (0 or 1). If 1.16 = 1 then the zero reference interlock is enabled and 1.03 won't see a reference until the line speed or speed pot is at zero. If 1.16 = 0 then 1.03 should equal 1.02. 3.01 should equal 2.01.
	If 3.01 has a value but 3.02 stays 0 then check 3.07 for a value of 1000. 4.02 should have a value and 5.01 should equal 4.02. If not, check Current Limit parameters 4.05 and 4.06 to be sure they are not both set to 0. Note that the default values are 4.05 = 1000 and 4.06 = 0 for a non-regen drive and 4.05 = 1000 and 4.06 = 1000 for a regen drive. Also check the Quadrant Enables (4.14 = 1, 4.15, 4.16, and 4.17 = 0 for a non-regen, 4.14, 4.15, 4.16, and 4.17 = 1 for regen drives).
Motor starts but doesn't rotate and drive trips in current limit.	Use a DC Current Clamp to check field current. Make sure the field current is motor nameplate.
	Check for mechanical binding, bearings on machine and motor should be adequately lubricated. Make sure in the case of a gearbox that it is adequately lubricated. In the case of belting, make sure the belts are the right tension (not too loose or too tight). If possible test the drive running the motor uncoupled from load (Remember ! A sheave, belt or gearbox can be considered part of the load).

178 Troubleshooting

DRIVE TROUBLESHOOTING

Symptom	Possible Solution(s)
Motor runs but speed is unstable.	Check parameter 3.01 (final speed demand) to be sure the speed reference is steady. If not source of line speed signal could be faulty (i.e. following a DC Tach or another motor controller .) Noise could also affect the incoming speed reference and cause the speed demand to oscillate. Check parameter 7.05 and use a voltmeter or if possible a graphical meter or an oscilloscope on the incoming reference. In the case of noise, place a 0.1 uF capacitor across the + and – of the line speed signal or between the wiper and ccw or the speed pot. Refer to the Start-Up Appendix for recommended wiring methods for further details on noise prevention and immunity.
	If 3.01 is steady, check 3.02 (speed feedback). If 3.02 is unsteady, what type of feedback is used ? If tach or encoder feedback is used then, as a test, set 3.12=0 and 3.13 =1 (armature feedback) and try running the motor with no load. If the motor speed regulates (within the 2 % spec), then encoder or tach may be suspect. If possible check signal or channels with a graphical meter or oscilloscope. Also check to be sure the tach or encoder coupling does not slip and is adequately connected.
	In the case of encoder or tach feedback, check to see the feedback scaling is correct. Refer to the Tach or Encoder Feedback section of the manual for further details.
	Is application cyclical (i.e. flywheel) ? Does the Bridge 1 and 2 LEDs toggle back and forth (on a regen) ? Set 3.09 = 60 and 3.10 = 30. Does the Bridge 1 and 2 LEDs toggle less frequently ? If necessary change 3.09 = 40 and 3.10 = 20.
	Does instability occur during accel or decel ? Extend the accel and/or decel times and check for improvement.
Motor slows down under load.	If in armature feedback, IR Comp may be required. If in current limit, field current could be set-up too weak, a mechanical issue must be addressed, the current limit is set too low, or the motor and drive is undersized.
Motor turns very slowly with no speed control.	In tach or encoder feedback ? Encoder phasing or tach polarity may be backwards.
Motor won't go to full speed.	In tach or encoder feedback ? The tach or encoder scaling may need to be adjusted. Field current could be too strong.
Motor runs away (ramps to full speed with no speed control).	If in armature feedback and the ramp enable is not "ON" (see parameter 2.02), during acceleration it could give the illusion that the drive is running away. If in tach or encoder feedback, the tach polarity or the phasing on the encoder could be backwards.
Motor runs but drive trips in current limit during accel.	Accel ramp is set too fast and should be extended.
	Mechanical friction is too high and the drive and motor doesn't have enough starting torque. Check for mechanical problems (i.e. bad bearings, lubrication, belting too tight, etc.).
	Current limit is set too low for the motor and/or application.
	Drive or gear ratio is undersized.
Drive won't reverse.	Is the drive a regen ?
	Bridge 2 Current Limit (4.06 = 0)
	Quadrant 3 enable (4.16) = 0 (disabled).
	Using a bipolar speed reference ? Check 3.01 for a negative value. If not, check 1.01 for a negative value. If 1.01 is negative but 1.03 = 0 then check 1.08 (min rev) and 1.09 (max rev). These parameters act as clamps and may clamp the negative reference to zero.

DRIVE TROUBLESHOOTING

<u>Symptom</u>	<u>Possible Solution(s)</u>
Blowing line fuses.	Check 3 Phase power with RMS voltmeter. High line (>490 VAC RMS) ? Power Transformer may need to be retapped to a lower voltage level.
	Check line with an oscilloscope. If line is severely notched, it may be required to install an isolation transformer or a line reactor to smooth the incoming line.
	An inversion fault may have occurred. This fault occurs often in accel or decel transition (where the load may exhibit some instability and/or bridge 1 and 2 toggle back and forth between motoring and braking). In this case, the motor armature voltage may momentarily rise above the incoming ac line. When this happens, an SCR on one bridge fires while another SCR on the other bridge is latched on. This causes a direct phase to phase short and one of or all the line fuses blow. Adjusting the accel/decel times may remedy the problem. Ensure the ramp enable (parameter 2.02 is on is on during normal accel/decel operation. Proper field set-up is critical to ensure that the drive doesn't have to pulse the motor to make speed and/or torque.
Blowing FS1 or FS3 internal fuses.	Power down drive. Using ohmmeter check the across the + and – of the field leads. Check the + and – to motor case and check for shorts. Open the peckerhead of the motor and verify the field connections. Beware of motors with dual field windings ! Be sure the field is wired for the correct voltage range. Replace internal fuses and disconnect the field. Power up drive. If the fuses don't blow and the drive display comes up then the motor field could be bad. If fuses still blow, then the field bridge or internal power supply could be bad or shorted.
Blowing Armature Fuse (regen).	Typically occurs on regen stop or fast decel. On a decel stop, extending the decel time often resolves this where load instability occurs.
	Can be caused by the field current regulator being improperly set-up (too strong or too weak). Check with ammeter to be sure the field is set-up correctly. In the case using field weakening for extended motor speeds beyond base speed this is especially critical. Refer to the Field and Field Weakening Set-Up sections of this manual for more information.
	SCR misfiring due to notches on the line (Do you have an isolation transformer or line reactor for protection?)
	SCR shorted.
	SCR and/or trigger circuit intermittently malfunctioning.
No display.	Check 3 phase AC line with voltmeter. If no readings, check circuit breaker or line fuses. If o.k. check the internal fuses FS1 and FS3. If open, replace. If they blow again see above for test procedure. Check the power supplies on the power module itself (TB4-33 to TB4-40) for the +24 VDC power supply. +24 VDC power supply may have failed.
Motor commutator sparking	Armature Voltage too high. Field could be too strong. Brushes and/or commutator may need maintenance.
Motor creeping with the speed reference at zero	Regen drive ? If so, enable the standstill logic. This can be enabled by placing a jumper between TB3-30 to TB4-40 on the power module or placing a jumper between TB5-5 and TB5-6 on the User Interface Board.
	Check parameter 1.04 (Offset) to be sure no offset has been entered via analog pot or digital keypad.

180 Troubleshooting

C. FAULT INDICATION

The M4000 has sophisticated protective circuits designed to prevent drive damage in the event that a motor, load, or power line problem occur. If any of these problems occur, the drive will automatically shut down to prevent damage. If the drive trips index display shows TRIP and the data message will flash. The data display shows a MNEMONIC or Fault Code to indicate the reason for the trip. **The last four trip codes are stored in Parameters 10.25 through 10.28** and are available for interrogation even if the drive has been powered down. The data stored in these parameters is up dated only by the next trip event.

Mnem	Code	Reason for the trip
AOC	121	Armature overcurrent. An instantaneous protection trip has been activated due to excessive current in the armature circuit. Power down and open the peckerhead of the motor. Inspect pigtailed and check for loose connections. Check resistance from motor case to each armature lead. May occur under acceleration if field current regulator has not been properly set for motor nameplate specs. Check field voltage.
AOP	126	Armature open circuit. Power down and open peckerhead of the motor. Inspect pigtailed and check for loose connections. Check brushes to see that they aren't worn and check to see that they are properly seated and the springs are holding them down against the commutator. Also check the armature contactor and its auxiliary. If the drive is enabled before the contactor is closed or the contactor opens before the drive is disabled, then the drive will trip on AOP. This is especially true where a power module is used. (The interface board provides the logic to interlock the opening and closing of the armature contactor and the drive's enable and disable).
cl	104	Current (control) loop open circuit. If the input reference is either 4-20mA or 20mA, this trip indicates that input current is < 3.5mA. Check current loop inputs setting table on parameters 7.28 and 7.27. Refer to flow diagram menu 7.
EEF	132	EEprom failure. Indicates that an error has been detected in the parameter set read from the EEPROM at power-up.
EPS	103	External power supply. Indicates an overload to the external 24VDC supply (TB4-33 to TB40). Check the external circuit connected to this supply for shorts, bad connections, etc.

Troubleshooting 181

Et	102	External trip. Parameter 10.34 = 1. The external trip can be set by the user to fault given a chosen condition. Danaher Motion has set as a default for the External trip to occur if the RMS line voltage input to the drive exceeds 510 VAC. If this trip occurs under these circumstances, then the transformer that supplies the power to the drive or cabinet needs to be retapped to lower the input supply voltage.
Fbl	119	Feedback loss. No signal from tach-generator or encoder. Place the drive in armature feedback with no load on the motor. In the case of a tach-generator , ramp the drive to 25 % speed and check tach voltage using a DC voltmeter. Set the voltmeter to AC Volts and check for AC ripple. In the case of an encoder, use a graphical meter or scope to check all channels with respect to encoder common. Also check the encoder DC supply. The most common culprit of the Feedback loss is a loose coupling between the stub shaft of the motor and the shaft of the DC tach or encoder. Check for integrity.
Fbr	109	Feedback reversal. The polarity of the tach or encoder feedback is incorrect. Swap the + and – leads of the tach or swap A and A NOT where an encoder is used.
Fdl	118	Field loss. No current in field supply circuit. Ohm the field windings to verify that the windings are not open. Make sure the field control (MDA-3 Internal or FXM5 External) has been set-up properly. Use an ammeter in series or a DC amp-clamp (depending on which is more appropriate) to verify the field current.
FOC	105	Field overcurrent. Excess current detected in field current feedback. If current feedback is present and firing angle is phased back, then the drive will trip on a field overcurrent fault. With the drive powered down, use a multimeter to verify that the field windings are not shorted. Open the peckerhead of the motor and verify the pigtailed have integrity with no bare wire showing. Verify that the proper field voltage and current are being applied to the motor.
hF	100	Hardware fault. A hardware fault has been detected during the self-diagnosis routine performed after power-up. Often noise on the AC line or on the +24, +10, or –10 VDC power supplies triggers a hardware fault. Check all wiring for shielding. Make sure that different levels of voltage (low level DC, 120 VAC control, and high voltage motor leads and AC line wiring) are routed in separate conduit and are routed in the control panel separately. Verify all grounds.

182 Troubleshooting

It	122	I x t trip. The integrating overload protection has reached trip level. Sometimes attempting to accelerate a load too fast causes an lxt trip. In this case, increase the acceleration time. (If the ramp enable Parameter 2.02 is set to 0 always there is no internal ramp !). Other cases may be mechanical in nature (bad or improperly lubricated bearings/gearboxes, etc). If possible, disconnect the power transmission from the motor to see if the drive operates properly given no load.
Oh	107	Overheat. SCR heatsink overtemperature. Parameter 10.33 = 0 (Only on drives fitted with stack thermistors). Ambient temperature may be unacceptable for proper operation of the drive. More cooling fans or a heat exchanger installed in the cabinet may be required.
Pc1	124	Processor 1 watchdog. Indicates a fault in the MDA1 hardware has been detected by malfunctioning of Processor 1 software.
Pc2	131	Processor 2 watchdog. Indicates a Processor 2 malfunction, or a software bug (MD29 option). Parameter 10.35 stores the MD29 fault code.

Fault Codes:

When there is a fault with the MD29 board, the drive will display a "A29". To find the actual fault, compare parameter 10.35 to the following table:

41	Parameter does not exist
42	Parameter write failure: Parameter is read only
43	Parameter read failed: Parameter is write only
44	Parameter write failed: parameter value is over range
45	Virtual parameter access failed: I/O link is not running
46	Internal error
47	Program is for different drive
48	Internal error
49	Internal error
50	Math error in the program, e.g. divide by zero
51	Array index is out of range
52	Internal error
53	Internal error
54	The CLOCK Task has overrun its time period
55	The ENCODER Task has overrun its time period
56	Internal error
57	I/O link has failed

Troubleshooting 183

PhS	101	Phase sequence. Connections to E1 and E3 are not the same phases as are connected to L1 and L3. Investigate and correct.
PS	125	Power supply. One or more of the internal power supply rails is out of tolerance. Frequently a potentiometer connected to the +10 or – 10 VDC power supply (TB1-1 and TB1-2 on the power module) is faulty or shorted. This will drag the power supply down. Where an interface board is connected to the power module via ribbon cable, check to see that the ribbon cable is connected properly. Check all external connections to the interface board. If satisfied with the wiring but the Mentor II continues to PS fault, power down and disconnect the interface board ribbon cable from the power module. Power up and check for PS fault.
ScL	105	Serial communications link loss. (Only in serial comms mode 3) No input data detected.
SL	120	Supply loss. One or more of the power input supply phases is open-circuit. May be notching in the AC line.
th	123	Thermistor. Motor protection thermistor has initiated a trip indicating windings overheating. This can be determined by TB1-8 to TB1-10. Trip threshold 50ohms ±5%. Reset 1.8Kohms.
thS	110	Thermistor short circuit. Thermistor input < 100 ohms

IN THE EVENT OF ANY TRIP, all RO parameter values are 'frozen' and remain so for interrogation while the cause of the fault is investigated. To enter parameter adjustment mode from the trip mode, press any of the five adjustment keys. To re-enter trip mode, go to Menu 00 and press = "Small Left" key

184 Troubleshooting

TRIP CODES IN NUMERICAL ORDER

Hf	100	Hardware fault
pHs	101	Phase sequence
Et	102	External trip
EhS	103	External power supply
cL	104	Current (control) loop open circuit
ScL	105	Serial communications link loss
FOC	106	Field overcurrent
Oh	107	Overheat
FdO	108	Field on
Fbr	109	Feedback reversal
thS	110	Thermistor short circuit
Fdl	118	Field loss
Fbl	119	Feedback loss
SL	120	Supply loss
AOC	121	Armature overcurrent
It	122	I x t trip
th	123	Thermistor
PC1	124	Processor 1 watchdog
PS	125	Power supply
AOP	126	Armature open circuit
Pc2	131	Processor 2 watchdog
EEF	132	EEprom Failure

Resetting A Fault Trip

When a fault trip occurs, further drive operation is temporarily inhibited. After determining the cause of the fault and correcting the problem, the drive may be reset by pressing the "RESET" button on the front panel, connecting the Reset input to common or the AC supply may be removed and re-applied.

Warranty on Mentor II M4000 Series DC Drives

Any Danaher Motion M4000 series DC Drive which proves upon evaluation to be defective in materials or workmanship within the period defined below shall be deemed under warranty. Cases where the M4000 drive has been subjected to accident, alteration, improper installation or operation, or damage by any conditions other than material or workmanship defects will NOT be deemed under warranty. Danaher Motion's liability for warranty coverage shall be limited to supplying replacement parts and repair labor time. If upon evaluation the drive is determined to be under warranty, the repaired drive will be shipped back to the customer at no cost for labor, parts, or shipping. The shipping status will be the same as received. Any requests for shipping status upgrades will incur shipping charges. In the case where on-site service is required; warranty coverage does NOT include labor time not related to the warranty defect, travel and living expenses, and any other expenses incurred.

- ? Power Units – 5 Years from the date of manufacture.
- ? All other components used M4000 chassis or enclosed units – 1 Year from the date of manufacture.

All repaired components and power units carry a 90 day warranty from the date of repair for parts repaired or replaced if no other warranty exists. Remaining original warranty will apply to repaired units if repaired at Danaher Motion in Charlotte, North Carolina.

Other products sold but not manufactured by Danaher Motion Engineered Systems Center will be covered under warranty consistent with the warranty policy maintained by the manufacturer of these products or as outlined above.

In the case where repair evaluation is required, contact your local DANAHER MOTION ENGINEERED SYSTEMS CENTER Distributor for a Material Return Authorization Number (MRA#). You must have an MRA# prior to return. Repair items are to be sent to:

Danaher Motion Engineered Systems Center
Attn: Repair Department
13500-J Southpoint Blvd.
Charlotte, NC 28273

Distribution Coast to Coast and International

Danaher Motion Engineered Systems Center Adjustable Speed Drive products are available worldwide through an extensive authorized distributor network. These distributors offer literature, technical assistance and a wide range of models off the shelf for fastest possible delivery and service.

In Addition, Danaher Motion Engineered Systems Center located in Charlotte, NC can integrate any Danaher Motion product into engineered systems. Coordination with PC or PLC based control and Man-Machine Interfaces can be provided as solutions to complex process control issues.

In U.S.A. and Canada **Danaher Motion Engineered Systems Center**

Customer Service: (704) 588-5693 x 275
Product Application: (704) 588-5693 x 205, 202
Product Literature Request: (704) 588-5693 x 275
Fax: (704) 588-5695
Web Site: <http://www.superiorelectric.com>
13500-J South Point Blvd.
Charlotte, NC 28273

In Europe **Danaher Motion** **Warner Electric S.A.**

Tel: 41 021 631 33 55
Fax: 41 021 636 07 04
La Pierreire
CH-1029 Villars-Ste-Croix, Switzerland

