

MMC for PC™

Hardware Manual

Version 3.2

NOTE

Progress is an on-going commitment at G & L Motion Control Inc. We continually strive to offer the most advanced products in the industry; therefore, information in this document is subject to change without notice. The illustrations and specifications are not binding in detail. G & L Motion Control Inc. shall not be liable for any technical or editorial omissions occurring in this document, nor for any consequential or incidental damages resulting from the use of this document.

DO NOT ATTEMPT to use any G & L Motion Control Inc. product until the use of such product is completely understood. It is the responsibility of the user to make certain proper operation practices are understood. G & L Motion Control Inc. products should be used only by qualified personnel and for the express purpose for which said products were designed.

Should information not covered in this document be required, contact the Customer Service Department, G & L Motion Control Inc., 672 South Military Road, P.O. Box 1960, Fond du Lac, WI 54936-1960. G & L Motion Control Inc. can be reached by telephone at (920) 921-7100 or (800) 558-4808 in the United States, or by email at glmotion.support@danahermotion.com.

Release 2705

Catalog No. (Order No.) M.1300.7621/Part Number M.1302.8337

©2005 G & L Motion Control Inc.

Windows 95, 98, NT, Microsoft, and MS-DOS are registered trademarks of Microsoft Corporation.

Pentium and PentiumPro are trademarks of Intel Corporation.

PiC900, PiCPro, MMC, MMC for PC, PiCServoPro, PiCTune, PiCProfile, LDO Merge, PiCMicroTerm and PiC Programming Pendant are trademarks of G & L Motion Control Inc.

Table of Contents: MMC for PC Hardware Manual

1	Safety Precautions	<i>I</i>
1.1	System Safety	1
1.1.1	User Responsibility	1
1.1.2	Safety Instructions	1
1.2	Safety Signs	2
1.3	Warning Labels	3
1.4	Safety First	4
1.5	Safety Inspection	4
1.5.1	Before Starting Operations	4
1.5.2	After Shutdown	4
1.6	Operating Safely	4
1.7	Electrical Service & Maintenance Safety	5
1.8	Safe Cleaning Practices	6
2	Introduction	7
2.1	Computer Workstation Requirements	8
2.1.1	Recommendations for MMC for PC Controller	8
2.2	Major Components	9
2.2.1	SERCOS Board	9
2.2.2	Analog Servo Board	10
2.2.3	Analog Servo Interface Unit (ASIU)	13
2.2.3.1	ASIU Components	14
2.2.3.2	ASIU Axis I/O	15
3	Installation of the MMC for PC Board and Software Suite	17
3.1	Installing the MMC for PC Board	17
3.2	Installing the Software Suite	20
3.3	Installing the Support Software	20
3.4	Removing the Software Suite	30
4	Installing the ASIU Module	31
4.1	Mounting Procedure for the ASIU	31
5	Power and Environment Requirements	33
5.1	General Power and Environment Requirements	33
5.2	ASIU Control Cabinet Specifications	33
5.3	Power Distribution for External Power Supply	34
5.3.1	MMC for PC Board External Power Supply Distribution	34
5.3.2	ASIU External Power Supply Distribution	35
5.4	24V Power Supply Sizing	37
5.4.1	MMC for PC Board 24V Power Supply Sizing	37
5.4.2	ASIU Power Supply Sizing	37
5.5	Grounding the System	40
5.6	Controlling Heat Within the System	41
5.7	Handling MMC for PC System Components	42
6	Wiring Guidelines - MMC for PC to Application	43

6.1	Recommended Signal Separation	43
6.2	Differential Devices for Analog and Encoder Signals Connected to the ASIU	46
7	MMC for PC Setup Procedures	47
7.1	Preparation for Maintenance or Setup	47
7.2	Connecting the MMC for PC System	49
7.2.1	Connecting the MMC for PC Board to an Application	49
7.2.2	Connecting the ASIU to an Application	49
7.3	Connecting an ASIU Network	50
7.4	Troubleshooting the MMC for PC Battery	51
8	Connections to External Devices	53
8.1	Connections to External Devices - MMC for PC	53
8.1.1	Optional External Power and Keyswitch Connections	53
8.1.2	Block I/O Port	54
8.1.3	Motion Control Connections for MMC for PC SERCOS Board	55
8.1.3.1	SERCOS Receive and Transmit Ports	55
8.1.4	Motion Control Connections for MMC for PC Analog Servo Board	56
8.1.4.1	ASIU Connector	56
8.2	Connections to External Devices - ASIU	57
8.2.1	General I/O Port	57
8.2.2	Power Connection	60
8.2.3	Axis Connectors	61
8.2.4	Auxiliary I/O Connector	66
9	MMC for PC Diagnostics	71
9.1	Description of MMC for PC Diagnostic Symbols	73
9.1.1	Scan	73
9.1.2	Access	74
9.1.3	Battery	74
9.1.4	Diagnostic	75
9.1.5	Diagnostic Error Text	75
9.1.6	Connection Status	76
9.1.7	Status Unknown	77
10	ASIU Diagnostics	79
10.1	Power-On Diagnostics	79
10.1.1	Power LED	79
10.1.2	Scan LED	79
10.1.3	Diagnostic LEDs	79

10.2 Run-Time Diagnostics	80
11 Troubleshooting the MMC for PC Battery	81
12 Operating the MMC for PC System	83
12.1 General Operation	83
12.2 ASIU Operation	84
12.3 LEDs	85
12.4 ASIU Output Theory of Operation (General I/O Connector)	88
12.5 Protecting from an Inductive Load	89
12.6 ASIU DC Output Theory of Operation (Axis Connector)	90
12.7 ASIU DC Input Operation (Axis, AUX, General Connectors)	90
12.8 ASIU Analog Output Theory of Operation (Axis Connectors)	93
12.9 ASIU Encoder Theory of Operation (Axis and AUX Connectors)	93
12.10 ASIU Analog Input Operation (AUX Connector)	95
13 MMC for PC Option Modules	96
13.1 General	96
13.2 Mounting the MMC for PC Option Module	96
13.3 Mounting a DeviceNet Module to a DLS Module	102
13.4 Network Interface Connections	105
13.4.1 DeviceNet Module	105
13.4.1.1 DeviceNet Connections	105
13.4.1.2 DeviceNet Port	106
13.4.1.3 DeviceNet Module LEDs	107
13.4.2 Profibus Module	108
13.4.2.1 Profibus Connections	108
13.4.2.2 Profibus Port	109
13.4.2.3 Profibus Module LEDs	110
13.4.3 Digital Line Shaft (DLS) Module	111
13.4.3.1 DLS Connections	111
13.4.3.2 DLS Module Port	112
13.4.3.3 DLS Module LEDs	113
14 Specifications	114
14.1 MMC for PC Analog Board Specifications	114
14.2 MMC for PC SERCOS Board Specifications	116
14.3 ASIU Specifications	118
14.4 MMC for PC Option Modules Specifications	123
14.4.1 DeviceNet Module Specifications	123
14.4.2 Profibus Module Specifications	125
14.4.3 Digital Line Shaft (DLS) Module Specifications	127
INDEX	IND-1

NOTES

1 Safety Precautions

READ AND UNDERSTAND THIS SECTION IN ITS ENTIRETY BEFORE UNDERTAKING INSTALLATION OR ADJUSTMENT OF MMC for PC CONTROL EQUIPMENT

The advice contained in this section will help users to operate and maintain the equipment in a safe manner at all times.

PLEASE REMEMBER THAT SAFETY IS EVERYONE'S RESPONSIBILITY

1.1 System Safety

The basic rules of safety set forth in this section are intended as a guide for the safe operation of equipment. This general safety information, along with explicit service, maintenance and operational materials, make up the complete instruction set. All personnel who operate, service or are involved with this equipment in any way should become totally familiar with this information prior to operating.

1.1.1 User Responsibility

It is the responsibility of the user to ensure that the procedures set forth here are followed and, should any major deviation or change in use from the original specifications be required, appropriate procedures should be established for the continued safe operation of the system. It is strongly recommended that you contact your OEM to ensure that the system can be safely converted for its new use and continue to operate in a safe manner.

1.1.2 Safety Instructions

1. Do not operate your equipment with safety devices bypassed or doors removed.
2. Only qualified personnel should operate the equipment.
3. Never perform service or maintenance while automatic control sequences are in operation.
4. To avoid shock or serious injury, only qualified personnel should perform maintenance on the system.

5.

ATTENTION- DANGER TO LIFE
Do not touch the main power supply fuses or any components internal to the power modules while the main power supply switch is ON. Note that when the main power switch is OFF, the incoming supply cable may be live.

6. **GROUNDING (Protective Earth)**

The equipment must be grounded (connected to the protective earth connection) according to OEM recommendations and to the latest local regulations for electrical safety. The grounding (protective earth) conductor must not be interrupted inside or outside the equipment enclosures. The wire used for equipment grounding (connection to protective earth) should be green with a yellow stripe.

7. If there is any doubt at all as to the safety of the equipment, you should set the main power switch to OFF and contact your OEM for advice.

1.2 Safety Signs

The purpose of a system of safety signs is to draw attention to objects and situations which could affect personal or plant safety. It should be noted that the use of safety signs does not replace the need for appropriate accident prevention measures. Always read and follow the instructions based upon the level of hazard or potential danger.

1.3 Warning Labels

Hazard warning

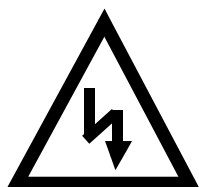

Danger Electric
Shock Risk

When you see this safety sign on a system, it gives a warning of a hazard or possibility of a hazard existing. The type of warning is given by the pictorial representation on the sign plus text if used.

The safety color is black on a yellow background with a black symbol. To ignore such a caution could lead to severe injury or death arising from an unsafe practice. If voltage levels are included in the text they must indicate the maximum level of the hazard in normal or fault condition.

Danger, Warning, or Caution warning



Symbol plus DANGER, WARNING or CAUTION:
These notices provide information intended to prevent potential personal injury and equipment damage.

Hot Surface warning



Symbol plus HOT SURFACE:
These notices provide information intended to prevent potential personal injury.

LED Radiation warning

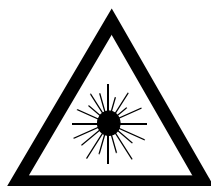

Symbol plus LED RADIATION. DO NOT STARE INTO BEAM. CLASS 2 LED PRODUCT:
These notices provide information intended to prevent potential personal injury.

1.4 Safety First

G&L Motion Control equipment is designed and manufactured with consideration and care to generally accepted safety standards. However, the proper and safe performance of the equipment depends upon the use of sound and prudent operating, maintenance and servicing procedures by trained personnel under adequate supervision.

For your protection, and the protection of others, learn and always follow these safety rules. Observe warnings on machines and act accordingly. Form safe working habits by reading the rules and abiding by them. Keep these safety rules handy and review them from time to time to refresh your understanding of them.

1.5 Safety Inspection

1.5.1 Before Starting Operations

1. Ensure that all guards and safety devices are installed and operative and all doors which carry warning labels are closed and locked.
2. Ensure that all personnel are clear of those areas indicated as potentially hazardous.
3. Remove (from the operating zone) any materials, tools or other objects that could cause injury to personnel or damage the system.
4. Make sure that the control system is in an operational condition.
5. Make certain that all indicating lights, horns, pressure gauges or other safety devices or indicators are in working order.

1.5.2 After Shutdown

Make certain all controlled equipment in the plant is safe and the associated electrical, pneumatic or hydraulic power is turned off. It is permissible for the control equipment contained in enclosures to remain energized provided this does not conflict with the safety instructions found in this section.

1.6 Operating Safely

1. Do not operate the control system until you read and understand the operating instructions and become thoroughly familiar with the system and the controls.

2. Never operate the control system while a safety device or guard is removed or disconnected
3. Where access to the control system is permitted for manual operation, only those doors which provide that access should be unlocked. They should be locked immediately after the particular operation is completed.
4. Never remove warnings that are displayed on the equipment. Torn or worn labels should be replaced.
5. Do not start the control system until all personnel in the area have been warned.
6. Never sit or stand on anything that might cause you to fall onto the control equipment or its peripheral equipment.
7. Horseplay around the control system and its associated equipment is dangerous and should be prohibited.
8. Know the emergency stop procedure for the system.
9. For maximum protection when carrying out major servicing requiring the system to be powered down, the power source should be locked using a lock for which only you have the key. This prevents anyone from accidentally turning on the power while you are servicing the equipment.
10. Never operate the equipment outside specification limits.
11. Keep alert and observe indicator lights, system messages and warnings that are displayed on the system.
12. Do not operate faulty or damaged equipment. Make certain proper service and maintenance procedures have been performed.

1.7 Electrical Service & Maintenance Safety

1. **ALL ELECTRICAL OR ELECTRONIC MAINTENANCE AND SERVICE SHOULD BE PERFORMED BY TRAINED AND AUTHORIZED PERSONNEL ONLY.**
2. It should be assumed at all times that the POWER is ON and all conditions treated as live. This practice assures a cautious approach which may prevent accident or injury.
3. To remove power:
**LOCK THE MAIN SWITCH IN THE OPEN POSITION.
USE A LOCK TO WHICH ONLY YOU HAVE THE KEY.**
4. Make sure the circuit is safe by using the proper test equipment. Check test equipment regularly
5. Capacitors take time to discharge. Care should be taken in manual discharging of capacitors

6. There may be circumstances where troubleshooting on live equipment is required. Under such conditions, special precautions must be taken:
 - Make sure your tools and body are clear of the areas of equipment which may be live.
 - Extra safety measures should be taken in damp areas.
 - Be alert and avoid any outside distractions.
 - Make certain another qualified person is in attendance.
7. Before applying power to any equipment, make certain that all personnel are clear of associated equipment.
8. Control panel doors should be unlocked only when checking out electrical equipment or wiring. On completion, close and lock panel doors.
9. All covers on junction panels should be fastened closed before leaving any job.
10. Never operate any controls while others are performing maintenance on the system.
11. Do not bypass a safety device.
12. Always use the proper tool for the job.
13. Replace the main supply fuses only when electrical power is OFF (locked out).

1.8 Safe Cleaning Practices

1. Do not use toxic or flammable solvents to clean control system hardware.
2. Turn off electrical power (lock out) before cleaning control system assemblies.
3. Keep electrical panel covers closed and power off when cleaning an enclosure.
4. Always clean up spills around the equipment immediately after they occur.
5. Never attempt to clean a control system while it is operating.
6. Never use water to clean control equipment unless you are certain that the equipment has been certified as sealed against water ingress. Water is a very good conductor of electricity and the single largest cause of death by electrocution.

2 Introduction

This document contains information for the MMC for PC Control System.

Block I/O information can be found in the Block I/O Modules Manual. Software information can be found in the PiCPro Online Help, the Function/Function Block Reference Guide, ASFB Manuals or on-line.

The MMC for PC board offers a complete solution to both machine and motion control directly from a PC. The board conforms to the PCI Bus Standard.

The major components of the MMC for PC motion control system are a PCI board, (analog servo or SERCOS), the MMC for PC Analog Servo Interface Unit (ASIU) and related connecting hardware. An optional mezzanine type MMC for PC Option Module is also available to facilitate network connections.

For SERCOS motion control, connections are made from the MMC for PC SERCOS board to SERCOS drives using a pair of fiber optic SMA connectors (one for transmitting signals and one for receiving signals.).

For analog motion control, an ASIU is connected directly to the MMC for PC Analog Servo board using a standard category 5 cable with RJ45 connectors. The MMC for PC Analog Servo board can also communicate with up to eight ASIUs by connecting one ASIU to the MMC for PC Analog Servo board and connecting additional ASIUs.

The MMC for PC is controlled by PiC Pro software that runs under the Windows NT or Windows 2000 Operating System. Ladder logic programming is used for machine control.

The MMC for PC is able to operate when the host PC is shut off. This is accomplished through a connection with an optional external +24VDC power supply.

2.1 Computer Workstation Requirements

2.1.1 Recommendations for MMC for PC Controller

Table 1: Recommendations for MMC for PC Controller

Computer	Minimally, 133 MHz Pentium processor with Windows NT4.0, 2000 or Professional Edition XP with PCI network card (ISA network cards are not recommended)
Memory	Consult operating system for additional memory needs
Monitor	800 X 600 or higher resolution, 16 bit or greater color
Disk drives	Typically, 100 MB of hard disk space required

IMPORTANT

Power saver option in BIOS should not be set when using an MMC for PC. Setting this option will cause a communications error when the computer is shut down.

2.2 Major Components

2.2.1 SERCOS Board

The SERCOS board provides connection capability to one SERCOS ring with up to 32 slaves. Three types of SERCOS boards are available (8, 16, or 32 slaves). The major components of the SERCOS board are illustrated in Figure 1 and include:

- A standard half size 32 bit 5 volt 33Mhz PCI card
- A 32-bit RISC processor running at 128 Mhz (includes numeric coprocessor)
- One SERCOS port that includes a fiber optic input connection and an output connection for one SERCOS ring.
- +24V Power connector
- A 9-Pin Block I/O interface port
- A lithium coin cell backup battery

Figure 1: Component View of MMC for PC SERCOS Control Board

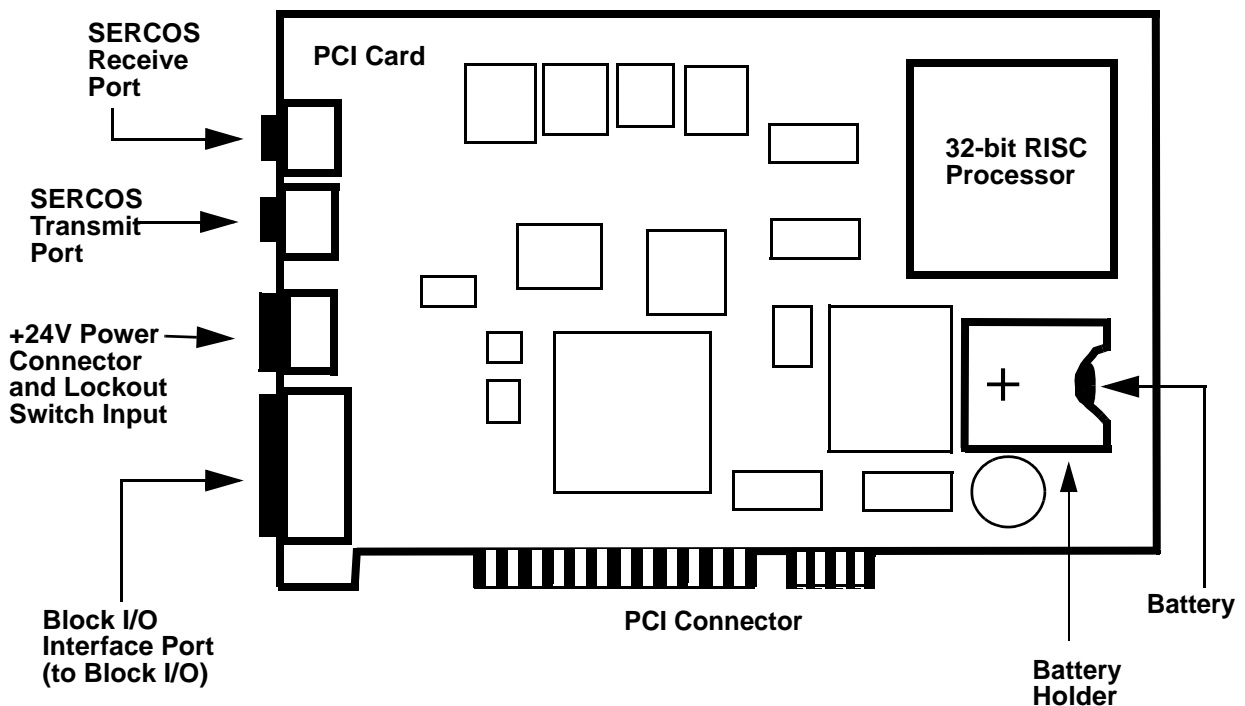
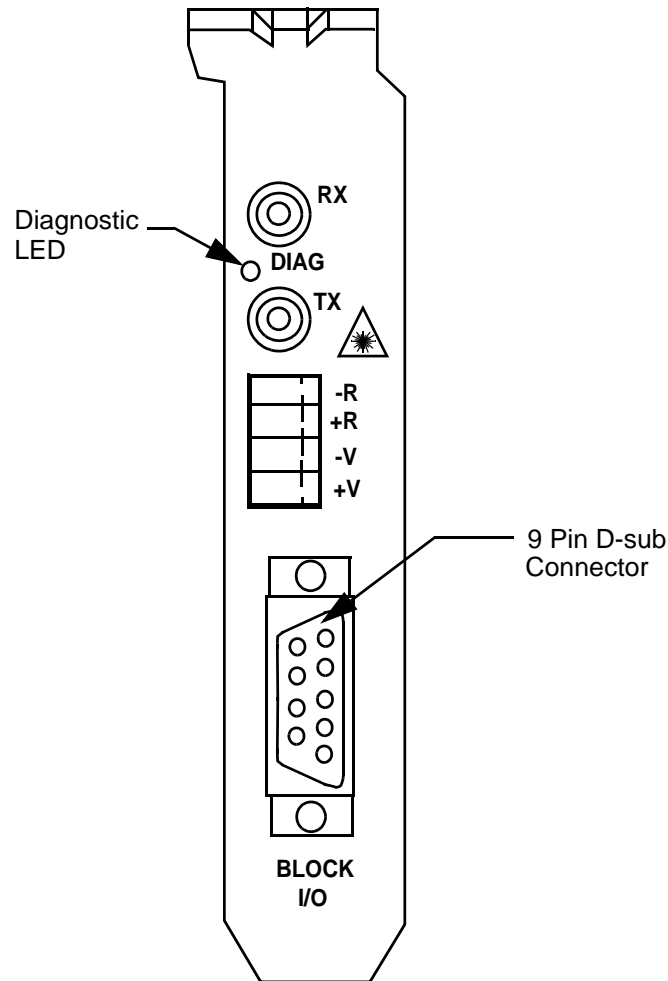

Figure 2: End Bracket Faceplate for SERCOS Board

2.2.2 Analog Servo Board

The major components of the Analog Servo board are illustrated in Figure 3 and include the following:

- A standard half size 32 bit 5 volt 33Mhz PCI card
- An 32-bit RISC processor running at 128 Mhz (includes numeric coprocessor)
- A RJ45 connector for communication with ASIUs
- A 9-Pin Block I/O interface port
- A lithium coin cell backup battery

Figure 3: Component View of MMC for PC Analog Servo Board

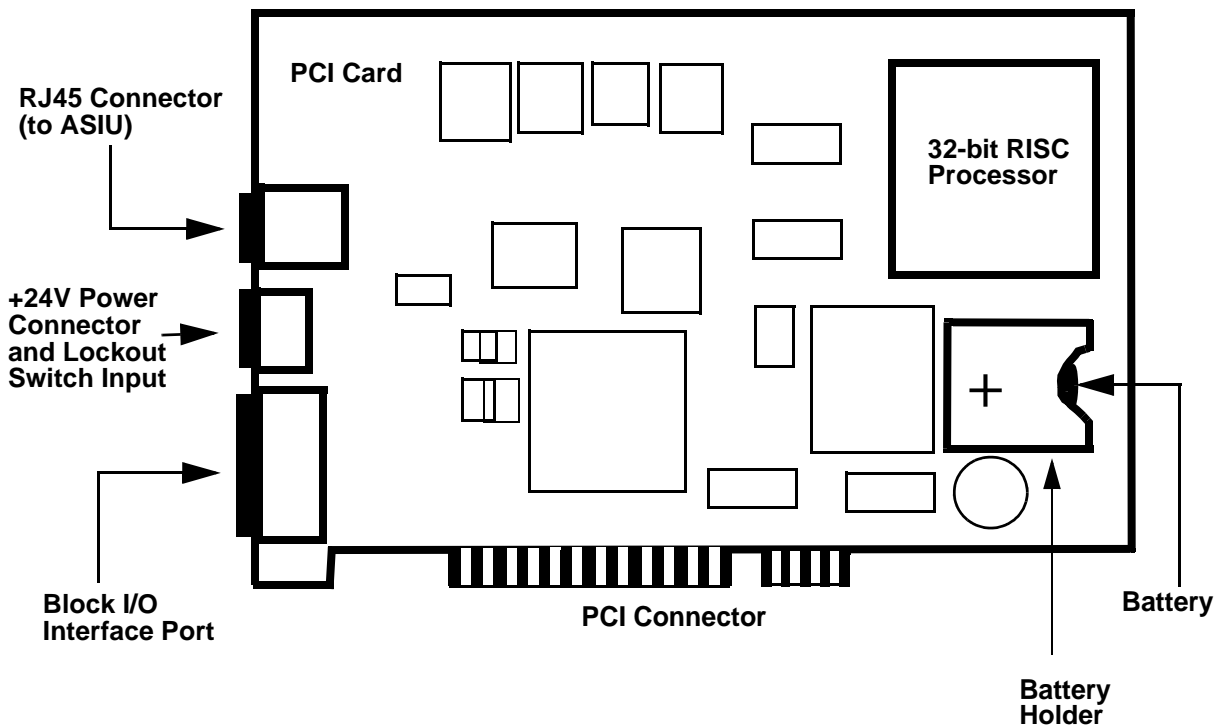
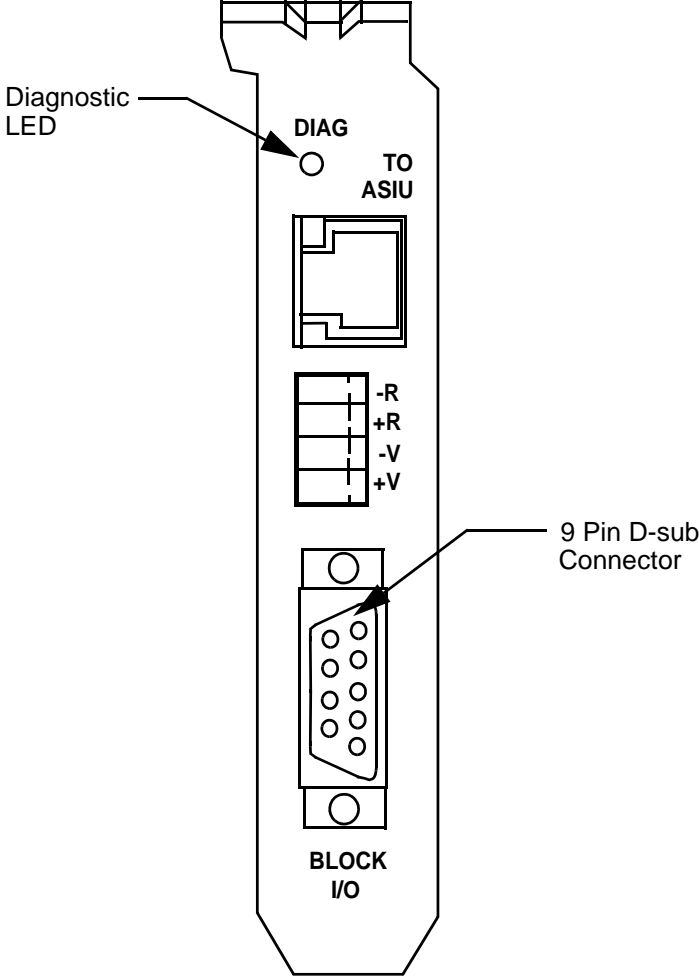

Figure 4: End Bracket Faceplate for Analog Board



2.2.3 Analog Servo Interface Unit (ASIU)

The Analog Servo Interface Unit (ASIU) provides servo axis interface signals and general purpose I/O for the MMC for PC Analog Board. The ASIU is available in two models:

- ASIU-A2 (2 1/2 servo axis unit)
- ASIU-A4 (4 1/2 servo axis unit)

Communication between the ASIU and the MMC for PC Analog Board (mounted in a Personal Computer) is accomplished through the use of a 10Base-T Ethernet interface. The MMC for PC Analog Board can communicate with up to eight ASIUs by connecting the ASIUs together.

Figure 5: Analog Servo Interface Unit (ASIU)

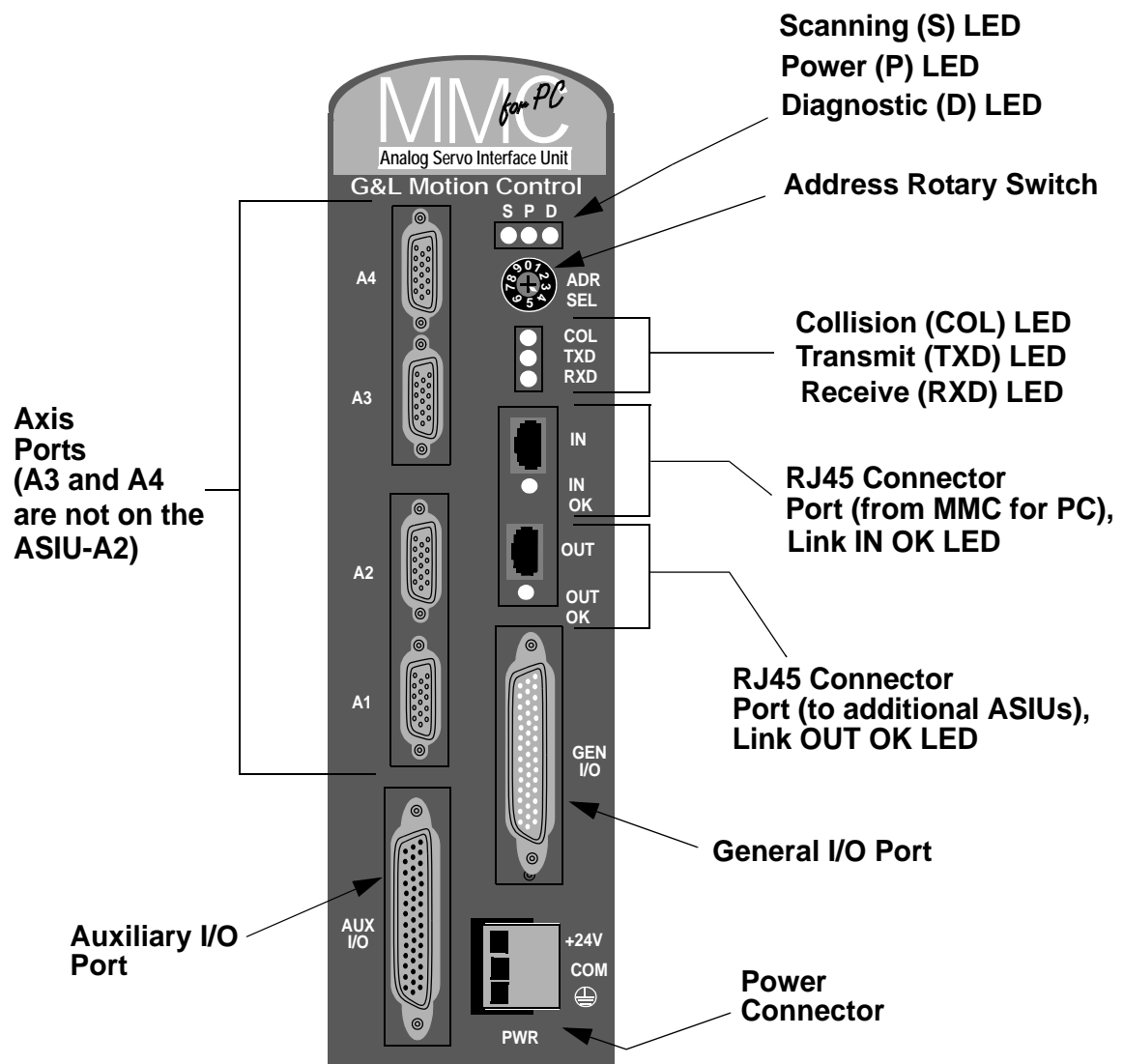

2.2.3.1 ASIU Components

Major external components of the ASIU include:

- Two RJ45 connectors and associated communications circuitry to communicate with the MMC for PC Analog Board and other ASIUs.
- A screwdriver-actuated rotary switch (0 through 9) that allows the user to define the ASIU address. Addresses 1 through 8 define valid ASIUs, and addresses 0 and 9 effectively remove the ASIU from the system (the two RJ45 connectors are still active, but the ASIU will not be seen by the MMC for PC Analog Board).
- A 3-pin power connector to supply 24VDC to the ASIU
- A General I/O port connector for connecting 16 inputs and 16 outputs to user devices.
- An Auxiliary I/O Port for connecting one quadrature incremental encoder, five fast DC inputs, one analog input channel and twelve DC inputs to user devices.
- Four Axis connectors are available on the ASIU-A4 and two are available on the ASIU-A2. Axis connections include one analog output, one encoder input, two DC outputs and one DC input to user devices.

LED indicators include the following:

- Scanning (Green) – Indicates CPU is communicating with the ASIU.
- Power (Green) – Indicates +5V is OK.
- Diagnostic (Yellow) – On briefly during startup. If it remains ON, ASIU has failed startup diagnostics.
- Link OK (Green) – Located near each of two RJ45 connectors. These LEDs indicate that the attached RJ45 cable is wired correctly and both ends are powered up.
- Collision (Red) – Located in the cut-out area of the plastic faceplate. Indicates that 2 or more ASIUs are at the same address.
- Transmit (Green) – Located in the cut-out area of the plastic faceplate. Indicates that this ASIU is sending a packet of information.

- Receive (Green) – Located in the cut-out area of the plastic faceplate. Indicates that this ASIU is receiving a packet of information.

2.2.3.2 ASIU Axis I/O

The ASIU provides conventional analog/digital interfacing for two or four drives.

Typical signals needed to interface to an analog drive are provided by the ASIU. The drive command is in the form of an analog voltage ($\pm 10V$). Feedback is accepted from quadrature type encoders with RS422 style differential outputs. Digital I/O (+24 VDC) is used for drive enable, reset, and fault signals.

The ASIU is offered in both 2 1/2 (ASIU-A2) and 4 1/2 (ASIU-A4) axis configurations. An axis is considered to be an analog output with a corresponding encoder input. In each configuration shown below, note that there is an extra encoder input. This is referred to as a half axis.

Table 2: Available Axis I/O for ASIU

Available I/O	ASIU-A2	ASIU-A4
Analog Inputs	1	1
Analog Outputs	2	4
Encoder Inputs	3	5
Axis DC Inputs	2	4
Axis DC Outputs	4	8
Axis Fast DC Inputs	3	5

NOTES

3 Installation of the MMC for PC Board and Software Suite

3.1 Installing the MMC for PC Board

1. Shut down and turn off your computer, monitor and all attached peripherals.
2. Unplug each component from the wall electrical outlet or surge protector/power strip.
3. Disconnect all power to the computer and MMC for PC control system.

WARNING	
	Before you install an MMC for PC board in the computer, make sure that power is disconnected from the computer and to the devices the MMC for PC is wired to. Make sure the computer is adequately grounded before installing an MMC for PC board. Any attempt to operate or service the computer without adequate ground may result in serious personal injury and/or damage to the MMC for PC board and control system.

4. Remove the computer cover as described in the documentation for your specific computer.
5. Locate an empty 32-bit PCI bus expansion slot in which to install the MMC for PC board.
6. At the back of the computer, the empty expansion slot should have a metal cover that is secured to the computer frame. Remove the screw that secures the expansion slot cover and remove the cover.

STATIC ELECTRICITY PRECAUTIONS

The MMC for PC board and internal components of the PC are sensitive to static electricity. The following precautions reduce the possibility of damaging the PC or MMC for PC board components:

Before handling the MMC for PC board or touching anything inside the PC, discharge your body's static electric charge by touching a grounded (earthed) surface. If the PC is connected to a grounded outlet, you can do this by touching the outside metal piece of the PC chassis.

Do not remove the MMC for PC from its antistatic bag until you are ready to install it.

When removing the board from the anti-static bag, hold it by the edges and the metal support mounting bracket. Avoid touching components on the board and the PCI Connectors.

Do not slide the board over any surface.

Avoid plastic, vinyl and styrofoam in your work area.

If you remove the MMC for PC board from the PC slot, immediately place it in an antistatic bag.

7. Remove the MMC for PC board from its anti-static bag.
8. Refer to Figure 6. Position the MMC for PC board over the empty expansion slot so the external connectors face the back of the computer and PCI Connector edge of the board is over the slot. Insert the board with the bottom edge level to the slot. *Never insert the board at an angle.* Carefully push the board straight down until the board is fully seated in the slot. Visually inspect the connection.

Figure 6: Installing the MMC for PC Board

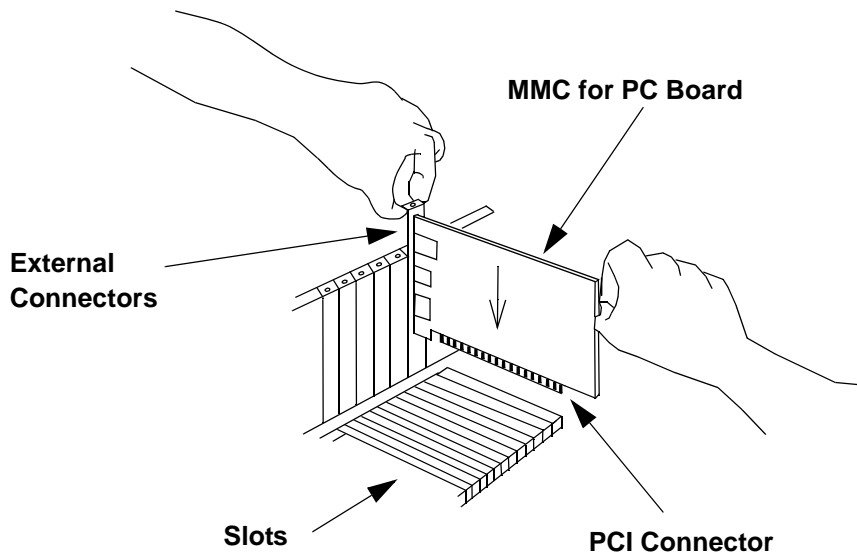

9. Attach the MMC for PC chassis to the back of the computer frame by reinserting and securing the screw from the expansion slot cover.

IMPORTANT

It is very important that the board is firmly attached to the computer frame. Failure to do so may cause poor connections to external devices or damage to the board.

10. Reattach and secure the screws for the computer cover.
11. Plug in all power cords and turn on the monitor. Turn on the computer. If you do not get the proper start-up display, check all connections and make the necessary changes.

3.2 Installing the Software Suite

The MMC for PC Software Suite CD contains 3 different software packages: PiCPro Monitor Edition, G&L Motion Control OPC Server and MMC for PC Support Software. At a minimum you must install the MMC for PC Support Software.

Instructions for installing the Support Software are provided in the following section titled "Installing the Support Software". It is recommended that you install this package first. The other three software packages are optional. They only have to be installed if there is a need to use them. The software packages can be installed in any order. To install any of these packages do the following:

1. Log in as a user with administrative privileges.
2. Insert the CD-ROM. Setup should launch automatically. If this does not happen, click the Start button on the Task bar, select Settings, select Control Panel, open Add/Remove Programs Icon and click Install.
3. Follow the instructions on the screen and select the appropriate item to install.

3.3 Installing the Support Software

This section describes procedures to install the Support Software required to support the MMC for PC hardware on Windows 2000™ and WindowsNT™. These programs include the driver, NT Socket Server, and a status program, which allow you to view the basic functions and settings of the hardware.

NOTE

If you have difficulty installing the Support Software, enter BIOS set-up and turn off all interrupts for the PCI slot that the MMC for PC is plugged into. Also, in BIOS, there may be a setting to indicate that the PC operating system is Plug and Play compatible. Set this to **YES** for Windows 2000 or to **NO** for WindowsNT.

1. Make sure the MMC for PC board is installed in the PC.
2. Log in as a user with administrator privileges.

Installation of the MMC for PC Board and Software Suite

3. Power on the PC. If you are using Windows 2000, a "Found New Hardware" wizard will appear. Click on the **Cancel** button.

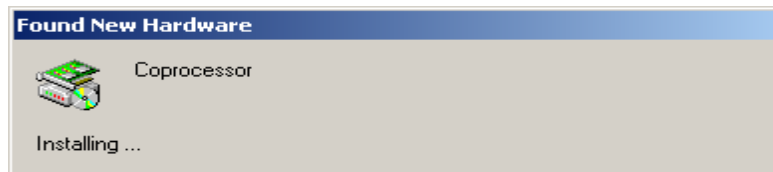

4. Insert the CD-ROM. Setup should launch automatically. If this does not happen, click the **Start** button on the Task bar, select Settings, select Control Panel, open the Add/Remove Programs Icon and click **Install**. From the list of selections, double click on **Install MMC for PC Support Software** and the "Welcome" window will be displayed.



NOTE

If you do not want to continue with the installation of the MMC for PC Support software, click on the **Cancel** button. The following window will be displayed. Click on the **Resume** button if you want to continue installing the software. Click on the **Exit Setup** button if you want to exit the software installation procedure. This option is available in all of the Support Software installation windows.

The screenshot shows a dialog box titled "Install" with a close button (X) in the top right corner. It features a question mark icon in a speech bubble. The text inside reads: "Setup is not complete. If you quit the setup program now, the program will not be installed. You may run the setup program at a later time to complete the installation. To continue installing, click Resume. To quit the Setup program, click Exit Setup." At the bottom, there are two buttons: "Resume" and "Exit Setup".

5. The "Read Me File" window will be displayed. This window includes a description of the installation procedure, an uninstall procedure and basic information on troubleshooting and support links. Click on the **N**ext button to continue.

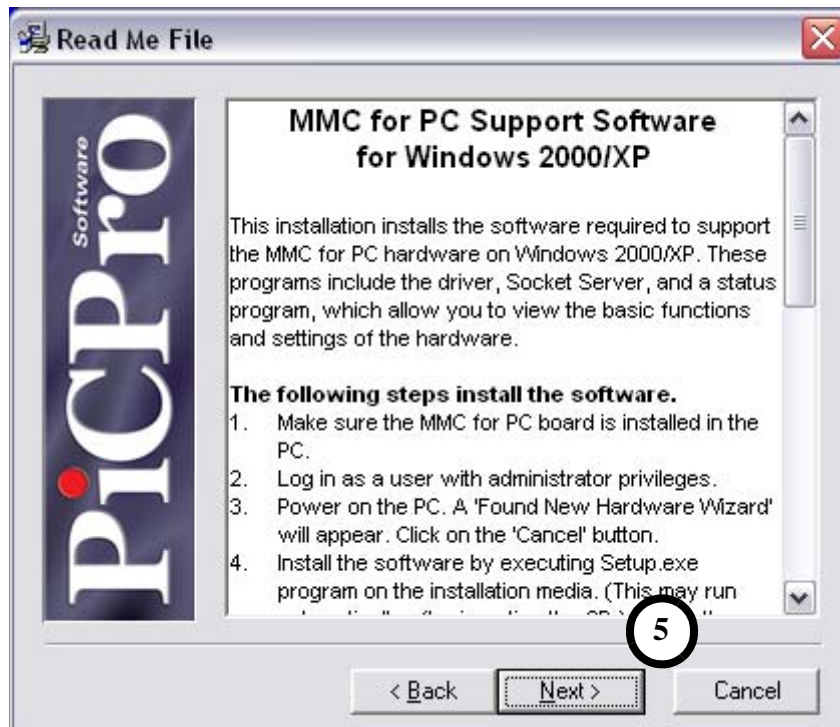

- The "License" window will be displayed. This window displays a description of the G & L Motion Control license agreement. Read and understand the license agreement.

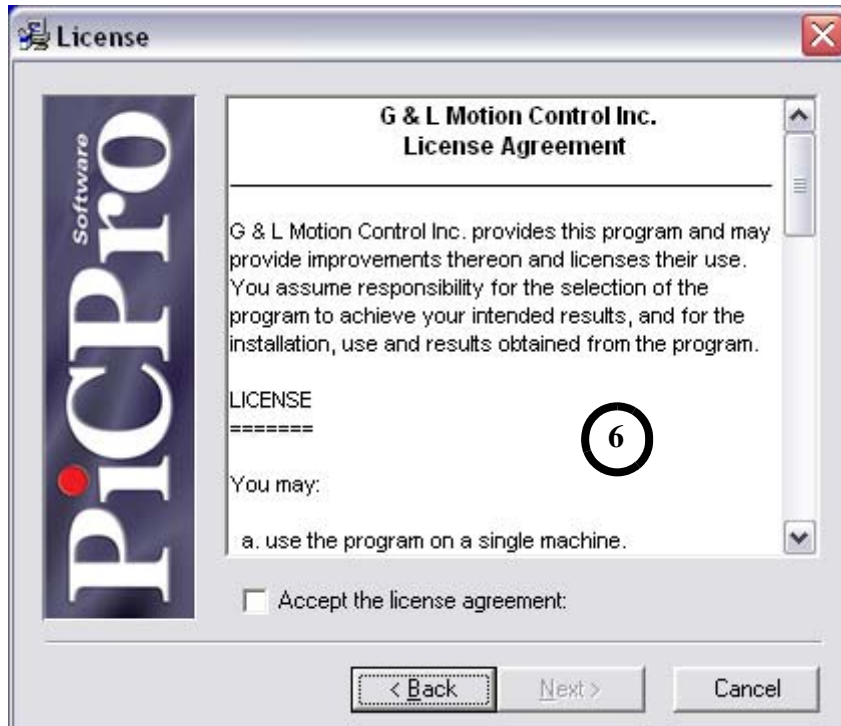

- Click in the **Accept the license agreement** box. A check mark will appear in the box and the **N**ext button will be available to choose. Click on the **N**ext button.

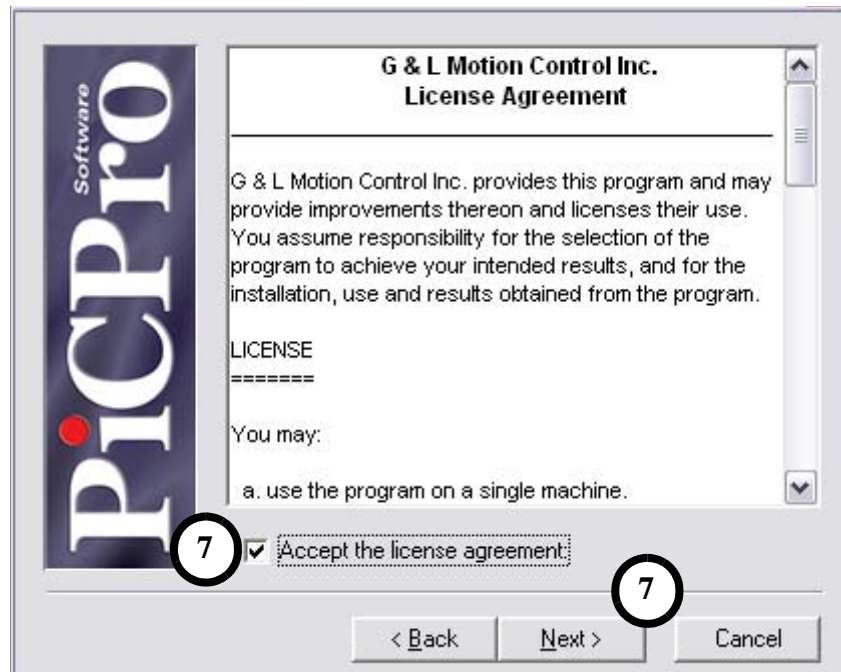

8. The "Choose Destination Location" window is displayed. The Support Software can be installed in a default destination folder or in a folder of your choice. Follow the directions given in the window. Click **N**ext to continue the software installation.

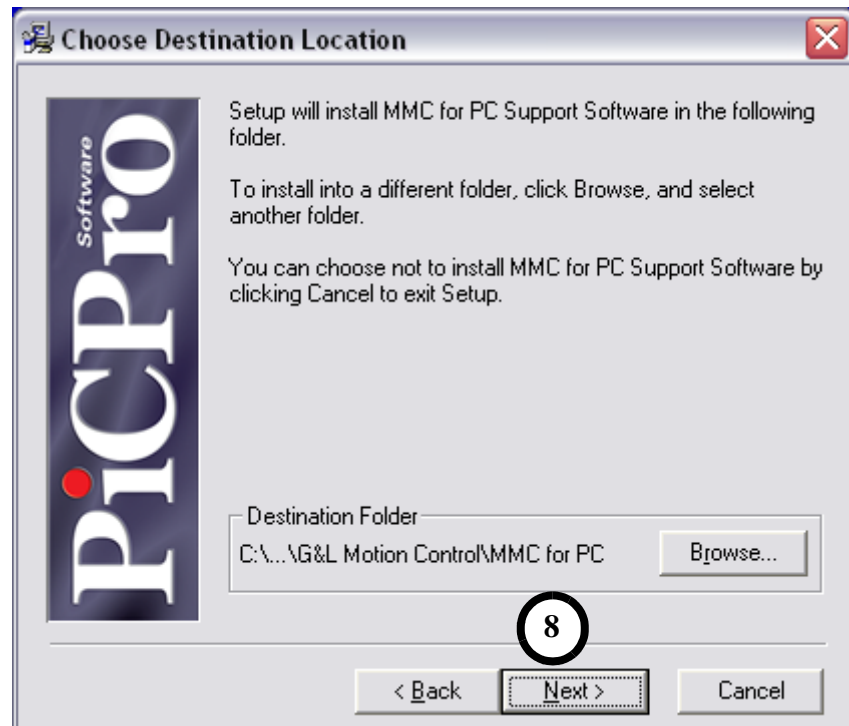

9. The "Start Installation" window will appear. Click on the **N**ext button to begin installation of the Support Software.

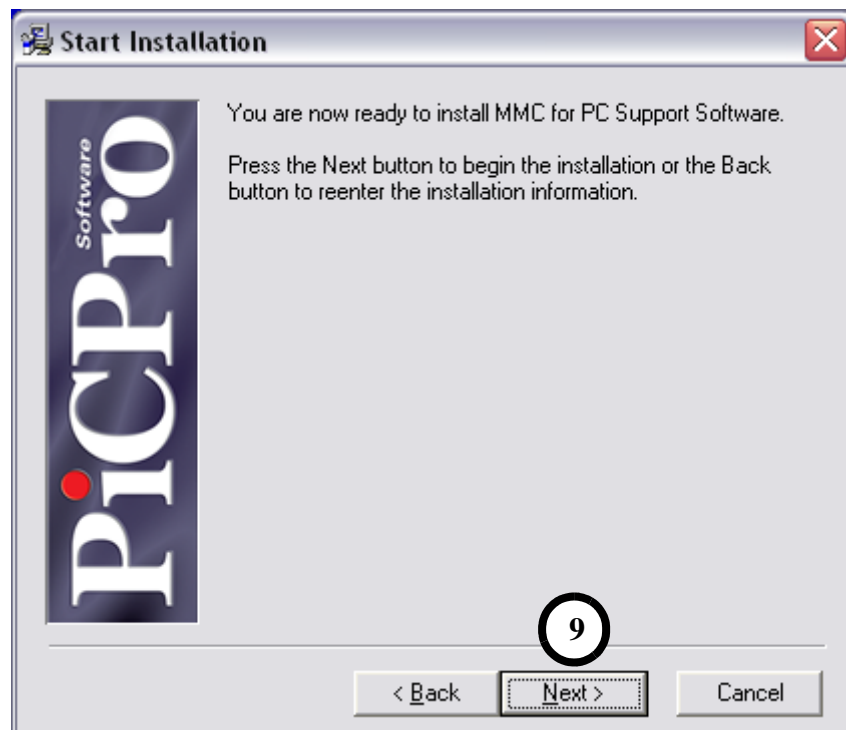

10. The "Installing" window will be displayed and the Support Software will be installed in the directory chosen in step 8 of this installation procedure.

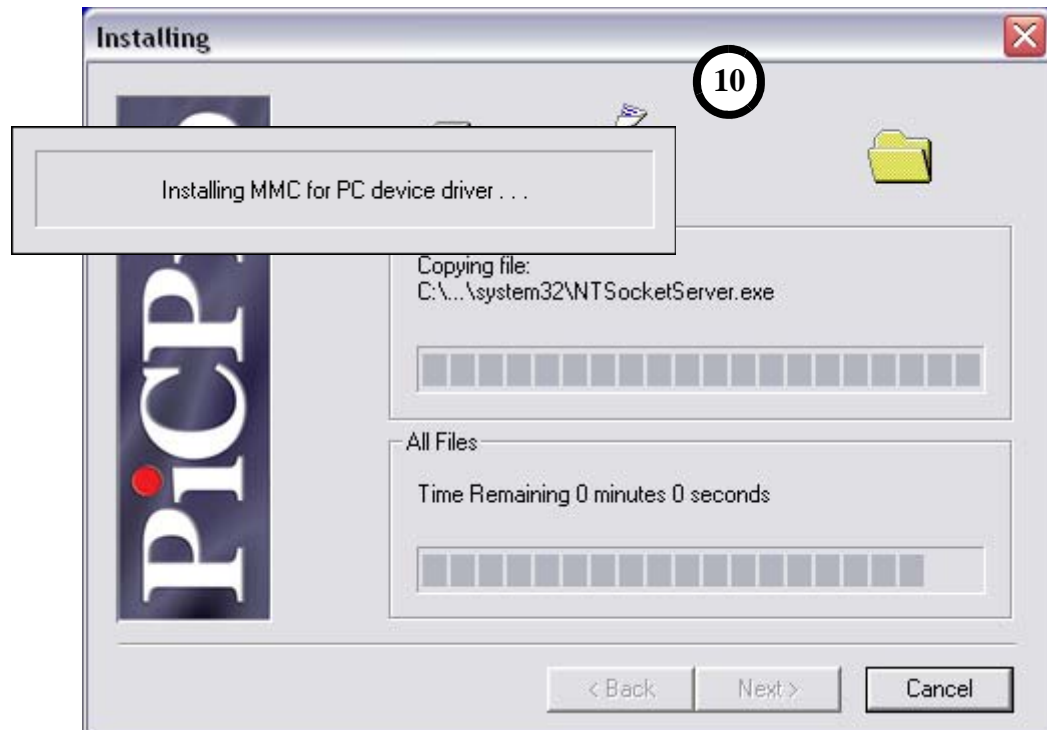

11. The "Installation Complete" window will be displayed when the software installation is completed successfully. Click on the **Finish** button.



12. The "Install" window will be displayed. Click on the **OK** button to restart the system and finish the software installation.

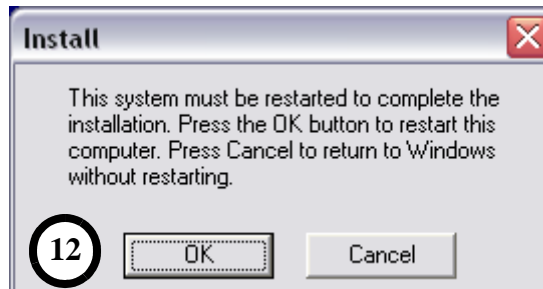

Installation of the MMC for PC Board and Software Suite

13. After the system restart is complete, click on the MMC for PC Status icon located in the lower right hand corner of the Windows 2000 or NT taskbar (near the Time icon). The MMC for PC Status Dialog Box will appear indicating the hardware connection status.

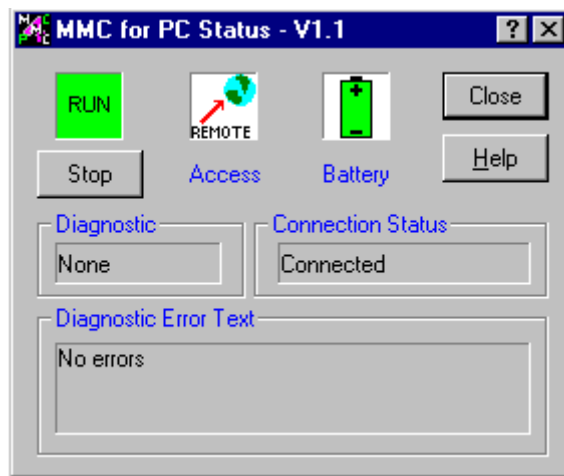
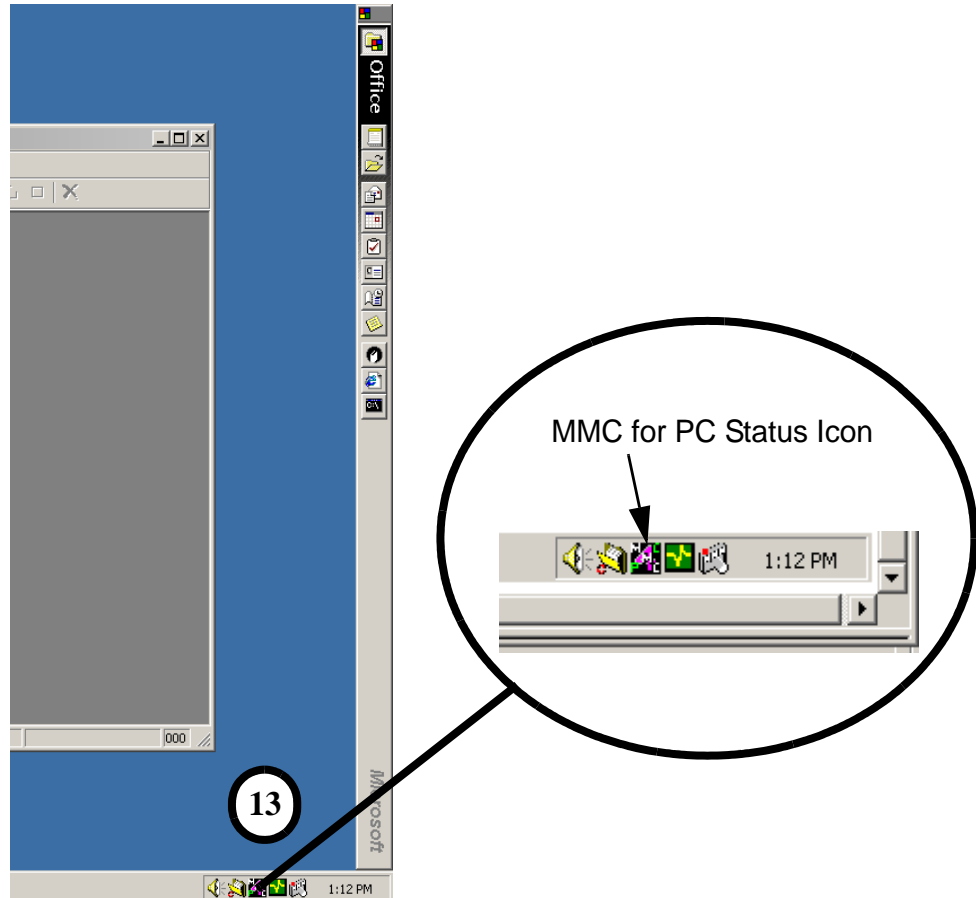

The button on the dialog is used to start or stop the ladder scan of the MMC for PC. When it is used to stop the scan, the following prompt appears requesting confirmation of the desire to stop the scan.

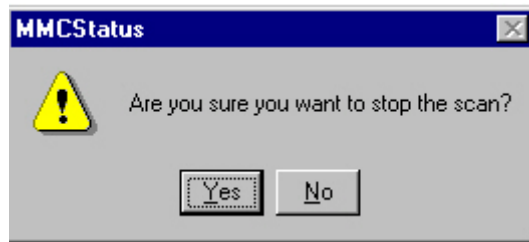

NOTE

The MMC for PC Status Dialog Box does not terminate when the "Close" or "X" buttons are clicked. This dialog box remains as an icon in the status area of the Windows desktop. This dialog box can be terminated and the status icon can be removed from the Windows desktop by using the task manager.

If the MMC for PC Status Dialog Box is terminated and its icon is removed from the Windows desktop, it can be restarted from the Windows "Start" menu under "Startup" by selecting MMC for PC Status.

3.4 Removing the Software Suite

1. At the Windows desktop, click on **Start**, choose **Settings**, click on **Control Panel** and double-click on **Add/Remove Programs**.
2. Select "MMC for PC Support Software" and click the **Add/Remove** button. Follow the uninstaller instructions.
3. Repeat steps 1 and 2 as needed for each of the following: OPC Data Access x.x Components, PiCPro Vx.x Monitor Edition and G & L Motion Control OPC Server Vx.x.

4 Installing the ASIU Module

4.1 Mounting Procedure for the ASIU

Mount the unit to your cabinet using the mounting slots on the ASIU. The ASIU may be mounted vertically or horizontally. The recommended size of mounting hardware is #10 bolts with #10 star washers (to ensure proper ground connection) as shown in Figure 7.

Figure 7: ASIU Mounting Dimensions

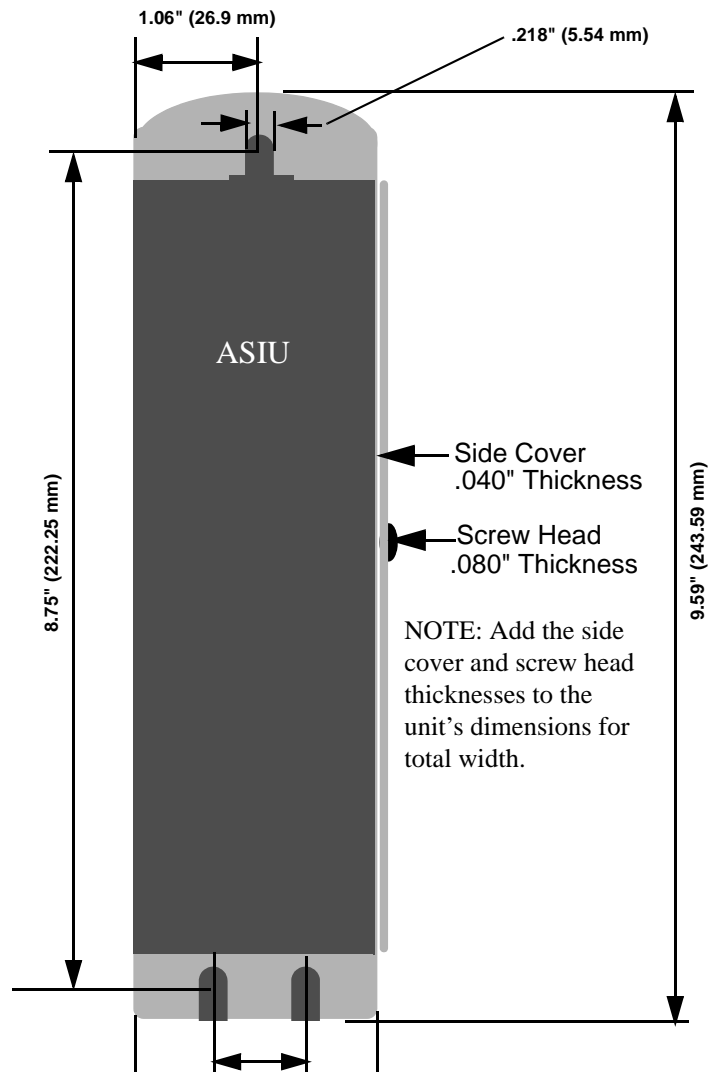

NOTES

5 Power and Environment Requirements

5.1 General Power and Environment Requirements

Protect the MMC for PC system from all the following:

- conductive fluids and particles
- corrosive atmosphere
- explosive atmosphere

Power is supplied to the MMC for PC PCI card from a PCI bus or an external +24VDC supply (not supplied). This arrangement allows the MMC for PC module to run when the host computer is shut off. When the host computer is shut off, a PCI power fail signal prevents input signals from being received by the MMC for PC card. The power draw for the MMC for PC card is approximately 7 watts.

The ASIU is suitable for operation in a pollution degree 2 environment (i.e., normally, only non-conductive pollution occurs). It is not required that the ASIU be installed in a control cabinet. However, installation of the ASIU in a control cabinet is recommended because a cabinet will protect the ASIU from dust and mechanical damage.

Install the system rack away from all sources of strong electromagnetic noise. Such noise can interfere with ASIU operation.

Diagrams and recommendations in this section may be modified if necessary so the wiring conforms to current NEC standards or government regulations.

5.2 ASIU Control Cabinet Specifications

If a control cabinet is used, the following guidelines should be followed:

- It should have a rating of NEMA-12 or better. A cabinet with this rating protects its contents from dust and mechanical damage.
- It must be large enough to provide adequate air circulation for the ASIU, drives, and other components. Always allow for adequate air flow through the ASIU vents.
- It must have a rigid vertical surface to mount the ASIU on.
- The door should open fully for easy access.

IMPORTANT
Post warnings according to National, State, or local codes for the voltage present in the control cabinet.

5.3 Power Distribution for External Power Supply

5.3.1 MMC for PC Board External Power Supply Distribution

The PC in which the MMC for PC board is installed should be located away from all sources of strong electromagnetic noise. Such noise can interfere with MMC for PC operation.

The power distribution drawing in Figure 8 shows an example for the power supply from an external +24VDC source.

The DC power source is connected to the MMC for PC system through a 4-pin connector. It plugs into the power connector of the MMC for PC. The negative (-) side from the power source and the ground from the PC must be connected to the Single-Point Ground (SPG).

Figure 8: Example of 24 VDC Power Distribution to an MMC for PC System

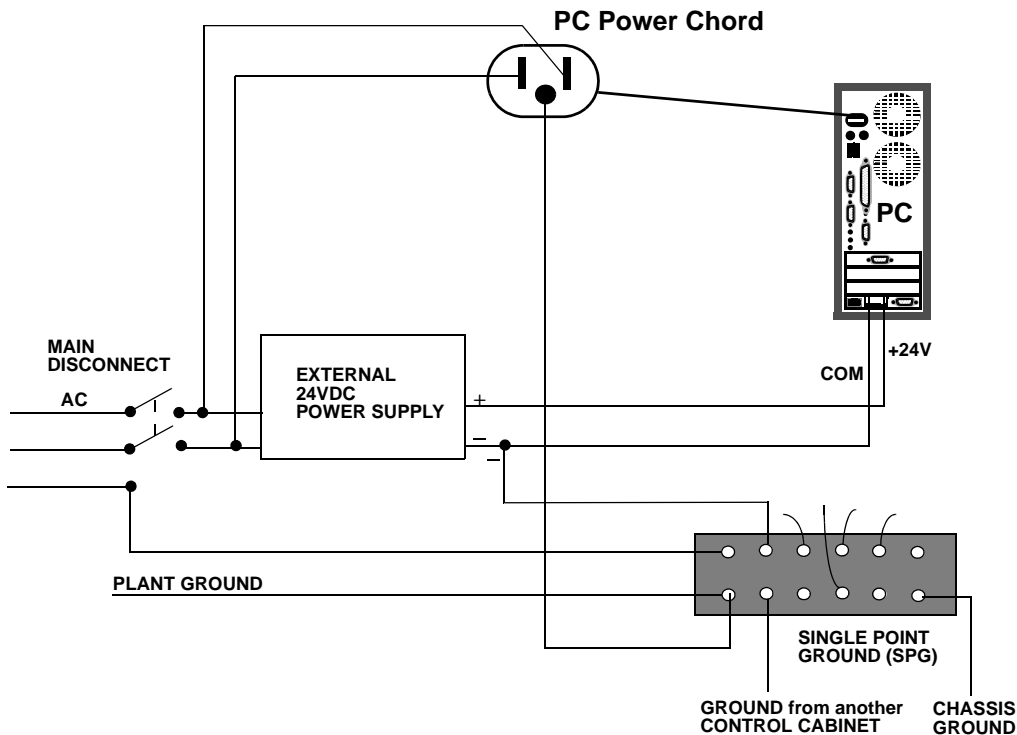

WARNING	
	No matter how the system is installed, before you connect the MMC for PC to the application, make sure that power is off to the system and to the devices the MMC for PC is wired to.

Devices connected to the PC may have their own power sources for input data or output control signals. You can use other wiring setups, provided that each one is:

- at the correct voltage and current levels for the module and the device.
- connected to the same Single-Point Ground that the MMC for PC uses.

It is recommended that the same main disconnect switch be used for the MMC for PC system and for all devices in the application.

5.3.2 ASIU External Power Supply Distribution

The ASIU requires an external DC power source. The power distribution drawing in Figure 9 shows an ASIU connected to a μ DSM Drive. The drive's 24 VDC power is supplied by the ASIU in this example. If the drive has its own external 24 VDC supply, the +24 V line would not be connected.

The DC power source is connected to the ASIU system through a 3-pin connector. It plugs into the power connector of the ASIU. The ground from the power source and ground from the ASIU must be connected to the Single-Point Ground (SPG).

Devices connected to the hardware may have their own power sources for input data or output control signals. You can use other wiring setups, provided that each one is:

- at the correct voltage and current levels for the module and the device.
- connected to the same Single-Point Ground that the ASIU uses.

Figure 9: Example of 24 VDC Power Distribution to an ASIU System

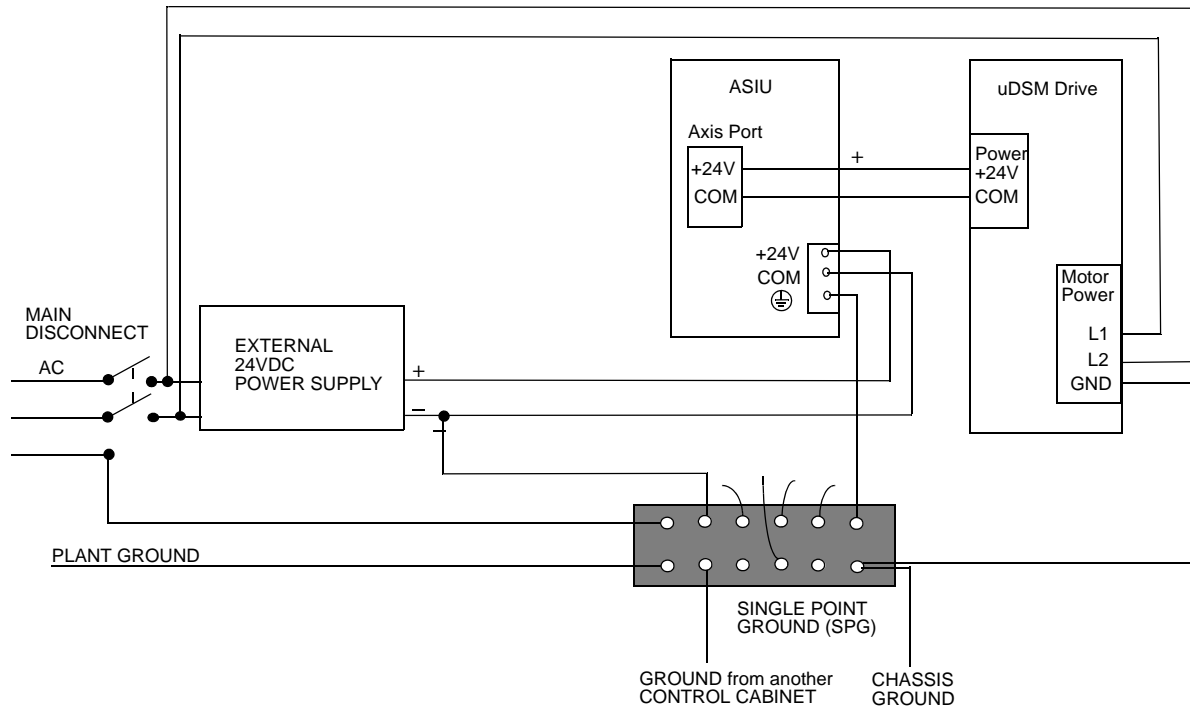

It is recommended that the same main disconnect switch be used for the ASIU system and for all devices in the application.

WARNING



No matter how the system is installed, before you connect the ASIU to the application, make sure that power is off to the system and to the devices the ASIU is wired to.

5.4 24V Power Supply Sizing

5.4.1 MMC for PC Board 24V Power Supply Sizing

The MMC for PC board can be powered by either the PCI bus or an external 24 VDC power supply. When the PC is on, the MMC for PC draws 300 mA from the PC's 24 VDC supply. When the PC is off, the MMC for PC board draws 300 mA from the external 24 VDC power supply.

5.4.2 ASIU Power Supply Sizing

An external 24 VDC supply is required to power the ASIU's internal circuitry and external I/O. The 24 VDC is distributed internally to three different buses or sections. When you size your power supply, you must ensure that the supply is large enough to handle the total load and that the maximum current capability of each bus is not exceeded. Table 3 shows the distribution of the 24 VDC power within the ASIU system:

Table 3: 24 VDC Power Distribution in ASIU System

Power Bus	Supplying Current To:	Maximum Current
1	Module Circuitry	.35 A
2	General I/O	5 A
3	Axis Auxiliary I/O	1 A

In most cases, one power supply can be used for the entire ASIU. However, depending upon the drives, and external I/O used in your application, you may split the power distribution into two or more power supplies. For example, the Axis I/O on an ASIU can be powered from the ASIU, from the drive or from another external power supply.

The worksheet in Table 4 can be used to size the power supply required by your application.

CAUTION	
<p>A possible ignition hazard within the ASIU exists if the maximum currents listed for Bus 2 or Bus 3 are exceeded or if excessive current is drawn at the 24 V line going into the ASIU. If these currents might be exceeded (due to improper wiring or external device failure), circuit breakers or fuses should be used in series with the 24 VDC going to and coming from the ASIU. Specifically, the circuit breakers or fuses should be sized for 10 A total on the 24V line coming into the ASIU, 1 A total from the +24 VDC OUT pins of the AXIS and AUXILIARY I/O connectors, and 5 A total from the I/O 24V pins of the GENERAL I/O connector. For maximum protection, use fast blow fuses. When using molded cables supplied by G&L Motion Control to connect the ASIU to the drives, no overload protection is required.</p>	

Table 4: 24 VDC Power Supply Sizing Worksheet

Line	ASIU Component	Max Current (mA)	Actual Current (mA)	Number of I/O	Col A Subtotal (mA)	Col B Current (mA)
1	ASIU-A2 or ASIU-A4 (Power Bus 1)					350
2	General Inputs	7.5	7.5			
3	General Outputs	250				
4		250				
5		250				
6		250				
7		250				
8	Subtotal, Power Bus 2 (Add Column A, Lines 2 thru 7, 5000 mA max)					
9	Axis inputs	7.5	7.5			
10	Axis outputs	100				
11		100				
12		100				
13		100				
14	Auxiliary inputs	7.5	7.5			
15	Fast inputs	7.5	7.5			
16	Current supplied by AXIS +24 VDC Out pins					
17	Current supplied by AUX +24 VDC Out pins					
18	Subtotal Power Bus 3 (Add Column A, Lines 9-17, 1000 mA max)					
19	Total Power (Add Column A, Lines 1, 8 and 18)					

Table 5 provides an example of how to use the worksheet to calculate the maximum current required for a theoretical four axes ASIU.

Table 5: 24 VDC Power Supply Sizing Example

Line	ASIU Component	Max Current (mA)	Actual Current (mA)	Number of I/O	Col A Subtotal (mA)	Col B Current (mA)
1	One ASIU-A2 or One ASIU-A4 (Power Bus 1)					350
2	General Inputs	7.5	7.5	16	120	
3	General Outputs	250	250	8	2000	
4		250	150	4	600	
5		250	100	4	400	
6		250				
7		250				
8	Subtotal, Power Bus 2 (Add Column A, Lines 2 thru 7, 5000 mA max)					
9	Axis inputs	7.5	7.5	4	30	
10	Axis outputs	100	100	2	200	
11		100	40	2	80	
12		100	25	4	100	
13		100				
14	Auxiliary inputs	7.5	7.5	16	120	
15	Fast inputs	7.5	7.5	5	37.5	
16	Current supplied by AXIS +24 VDC Out pins		100		100	
17	Current supplied by AUX +24 VDC Out pins		300		300	
18	Subtotal Power Bus 3 (Add Column A, Lines 9-17) 1000 mA max					
19	Total Power (Add Column A, Lines 1, 8 and 18)					4437.5

5.5 Grounding the System

The ground of the MMC for PC system power source must be connected directly to a *Single Point Ground* (SPG) tie block. The tie block should be made of brass or copper, bolted or brazed to the control cabinet. If the tie block is bolted rather than brazed, scrape away paint and grease at the point of contact. Put star washers between the tie block and the cabinet to ensure good electrical contact.

Metal enclosures of power supplies, drives, etc., should also have good electrical contact with the SPG.

IMPORTANT

The Single Point Ground should be the only common point for all the ground lines. If not, ground loops may cause current flow between components of the system which can interfere with proper operation of the MMC for PC board.

Devices to be connected directly to the Single Point Ground include:

1. Plant safety ground.
2. The metal panel or cabinet of the host PC or in which the ASIU is mounted.
3. "Common" or "0 V" lines from power supplies that provide external power to the I/O modules and the devices to which they are connected.
4. Chassis grounds from the devices themselves, such as device drivers, machinery, and operator interface devices.
5. AC common line from the noise filter, if any.
6. The ground of the power source of the computer workstation, if any, from which you monitor the system operation. An AC outlet in the control cabinet is recommended.
7. Single point grounds from other control cabinets, if any, in the system.

IMPORTANT
<p>You must ensure that the "0V" or "Common" of all devices connected to the MMC for PC or the ASIU are connected to Single Point Ground (SPG). Failure to do so may result in erratic operation or damage to the devices.</p> <p>An example device connected to the MMC for PC system is the power source that supplies 24VDC power to the MMC for PC.</p> <p>Note that some devices (for example, a Personal Computer) may have their "0V" and "Chassis" connected together internally, in which case only one connection has to be made to SPG for that device.</p> <p>Also, you must ensure that the ASIU "Chassis" connection is connected to SPG, and that the ASIU is mounted to a metal panel or enclosure that is connected to SPG.</p>

5.6 Controlling Heat Within the System

Table 6: Operating Limits for the MMC for PC System

Temperature	5 to 55° C (41 to 131° F)
Relative humidity	5 to 95%, non-condensing

Make sure that the MMC for PC system is not in an environment that raises the temperature above the Operating Limits shown above. Also protect the MMC for PC system from electrical noise.

The ASIU hardware case is designed to promote air circulation and dissipate heat. The ASIU can be mounted vertically or horizontally to take advantage of this design. Normally no fans or air conditioners are needed. However, if the environment outside the control cabinet is hot or humid, you may need to use a fan, heat exchanger, dehumidifier or air conditioner to provide the correct operating environment.

Make sure that components installed in the cabinet with the ASIU do not raise the temperature above system limits and that any hot spots do not exceed specifications. For example, when heat-generating components such as transformers, drives or motor controls are installed, separate them from the system by doing one of the following:

- Place them near the top of the control cabinet so their heat output rises away from the ASIU.
- Put them in another control cabinet above or to one side of the cabinet with the ASIU. This protects the ASIU from both heat and electrical noise.

The ASIU itself is a source of heat, though in most installations its heat dissipates without harmful effects. System heat is generated from power dissipated by:

- field side input/output components
- other components within the ASIU

IMPORTANT

If the MMC for PC system is operated outside the recommended limits, it may be damaged. This will void the warranty.

5.7 Handling MMC for PC System Components

Packaging protects the MMC for PC's internal circuitry against damage in shipping and handling.

The case protects the ASIU's internal circuitry against mechanical damage in shipping and handling.

However, like any electronics device, the circuitry can be destroyed by:

- moisture condensing inside the package
- static discharge
- exposure to a magnetic field strong enough to induce a current in the circuitry
- vibration and other related hazards

There is no need to open the ASIU case. There are not any serviceable parts inside the case.

6 Wiring Guidelines - MMC for PC to Application

The MMC for PC board relies on electrical signals to report what is going on in the application and to send commands to it. The MMC for PC Analog Board relies on the ASIU to provide electrical signals to report what is going on in the application and to send commands to it. In addition, signals are constantly being exchanged within the system. The MMC for PC system is designed for use in industrial environments, but some guidelines should be followed.

6.1 Recommended Signal Separation

G&L Motion Control recommends separation of low level signals from high voltage or high current lines. This includes 1) block I/O and network wiring between the MMC for PC board and the ASIU, and 2) encoder, analog, communications and fast DC inputs to the ASIU. Maintain at least one inch of separation around signals.

Figure 10 and Figure 11 illustrate the recommended connections for the Optional External Power Supply when using EMC compliant products. Note that a capacitor is connected to the +24 VDC supply. To prevent excessive conducted emissions from a DC power source (typically +24 V) used for digital I/O, a 1000 picofarad capacitor should be used. Connect the capacitor from the +24 VDC to COMMON at the distribution terminals.

Figure 10: Recommended EMC Compliant Connections for the MMC for PC Board

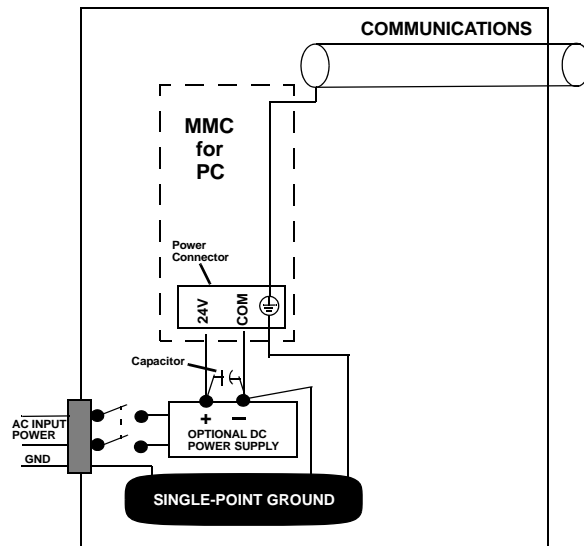
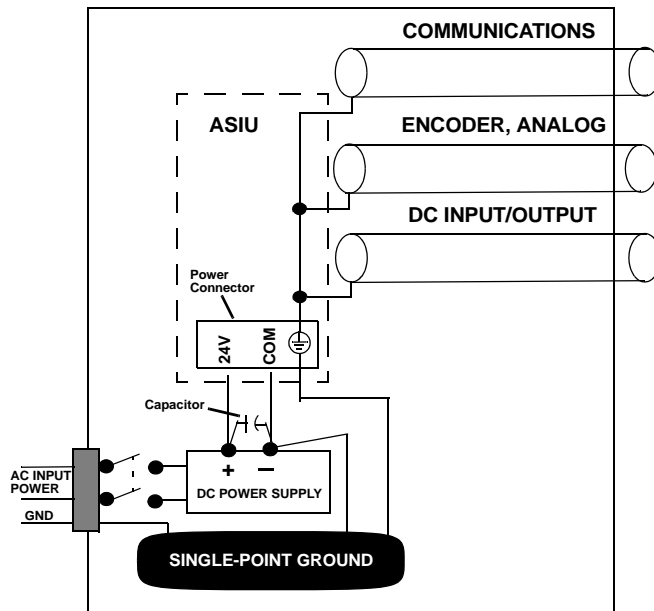
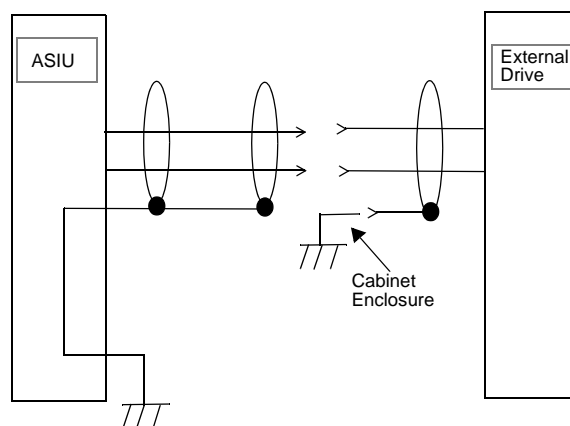

Figure 11: Recommended EMC Compliant Connections for the ASIU



If the ASIU is mounted inside a control cabinet, connect the shields of shielded cables at the ASIU. Figure 12 illustrates shielded cable entering/leaving the cabinet.

Figure 12: Connecting Shielded Cable



The two different methods of terminating shields are used to accommodate two different immunity requirements. Immunity required inside an enclosure is considered lower because cables are typically less than three meters in length and/or can be separated from each other and from noise sources.

Immunity required external to an enclosure is considered higher because the user may have less control over the noise environment. Low level signal cables that can be external to an enclosure are tested at a 2 KV level for electrical fast transients (EFTs). Low level signals that can be less than three meters in length or can be separated from noise sources are tested at a 1 KV level.

Under the stated conditions, there will be no disturbance of digital I/O or encoder operation. For analog signals, there may be momentary disturbances but there will be self-recovery when the noise subsides.

Do not operate transmitters, arc welding equipment, or other high noise radiators within one meter of an enclosure that has the door open. Continue to equip inductive devices, if they are in series with a mechanical contact or switch, with arc suppression circuits. These devices include contactors, solenoids and motors. Shield all cables that carry heavy current near the system, using continuous foil wrap or conduit grounded at both ends. Such cables include power leads for high-frequency welders and for pulse-width-modulated motor drives.

WARNING	
	<p>Use care when wiring I/O devices to the MMC for PC system and when plugging in cables. Wiring the wrong device to the connector or plugging a connector into the wrong location could cause intermittent or incorrect machine operation or damage to equipment.</p>

6.2 Differential Devices for Analog and Encoder Signals Connected to the ASIU

A *differential* device receives or sends one signal over two wires (typically a shielded twisted pair). The input/output voltage at the second terminal is the inverse of the first. Information is received/sent as the difference between the two voltages. A differential digital pulse train is illustrated in Figure 13.

Figure 13: Differential Digital Pulse Train

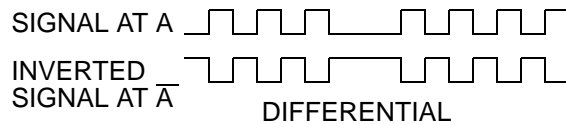

The advantages of using differential signals are:

1. A differential signal is less susceptible to electromagnetic noise. Static or other interference affects both of the twisted-pair wires equally, so the difference between the normal and inverted voltage remains unchanged. A differential signal can be transmitted over a much longer distance or in a much noisier environment than a single-ended one.
2. ASIU hardware circuitry can detect signal loss from an encoder if the signal is differential. The application program can be set to shut down the application if such an error is detected.

IMPORTANT
<p>Always use differential drivers or differential inputs.</p>

7 MMC for PC Setup Procedures

7.1 Preparation for Maintenance or Setup

WARNING	
	<p>Table 7 and Table 8 provide information intended to assist in the prevention of potential personal injury and equipment damage. These procedures must be performed before performing maintenance or setup procedures.</p>

Table 7: Preliminary Maintenance or Setup Procedures - MMC for PC Board

In order to:	Do the following:
Turn off the entire application.	Turn off main disconnect (which should also turn off all external power supplies to the application); unplug the DC power to the MMC for PC.
Wire the I/O to the application.	Turn off main disconnect (which should also turn off all external power supplies to the application); unplug the DC power to the MMC for PC.
Download an application program into the memory.	Make sure power is on.
Stop the scan.	From the PC Workstation - use the Stop Scan commands in the MMC for PC PiCPro software.

Table 8: Preliminary Maintenance or Setup Procedures - ASIU

In order to:	Do the following:
Turn off the entire application.	Turn off main disconnect (which should also turn off all external power supplies to the application); unplug the DC power to the ASIU.
Wire the I/O to the application.	Turn off main disconnect (which should also turn off all external power supplies to the application); unplug the DC power to the ASIU.
Connect/disconnect the ASIU with the MMC for PC Analog Board.	Turn off main disconnect (which should also turn off all external power supplies to the application); unplug the DC power to the ASIU.
Connect/disconnect the ASIU with other ASIUs.	Turn off main disconnect (which should also turn off all external power supplies to the application); unplug the DC power to the ASIUs.

7.2 Connecting the MMC for PC System

7.2.1 Connecting the MMC for PC Board to an Application

1. Turn off the main disconnect switch in the system control cabinet. If some devices are not powered from the control cabinet, turn them off also.
2. Attach the connectors according to the appropriate wiring diagrams.
3. Turn on power to the system.

7.2.2 Connecting the ASIU to an Application

1. Turn off the main disconnect switch in the control cabinet. If some devices are not powered from the control cabinet, turn them off also.
2. Attach the connectors according to your diagrams.
3. Turn on power to the system including the MMC for PC Analog Board. The following occurs:
 - The PWR light goes on and stays on.
 - The DIAG light goes on, then goes off when the ASIU passes its diagnostic tests.
 - The SCAN light goes on.
 - The application starts to work under control of the system.
4. If an application program is not in system memory of the MMC for PC Analog Board, use the download command in the PiCPro software to place it there.

7.3 Connecting an ASIU Network

The MMC for PC Analog Board communicates with the ASIUs using a subset of the 10Base-T Ethernet protocol. Connection to the first ASIU is made from the MMC for PC Analog Board to the IN RJ45 connector on the first ASIU. Refer to Figure 14.

Connection from the first ASIU to the second ASIU is made from the first ASIU's OUT connector to the second ASIU's IN connector. Connection from ASIU to ASIU is the same for additional ASIUs.

Figure 14: ASIU Network

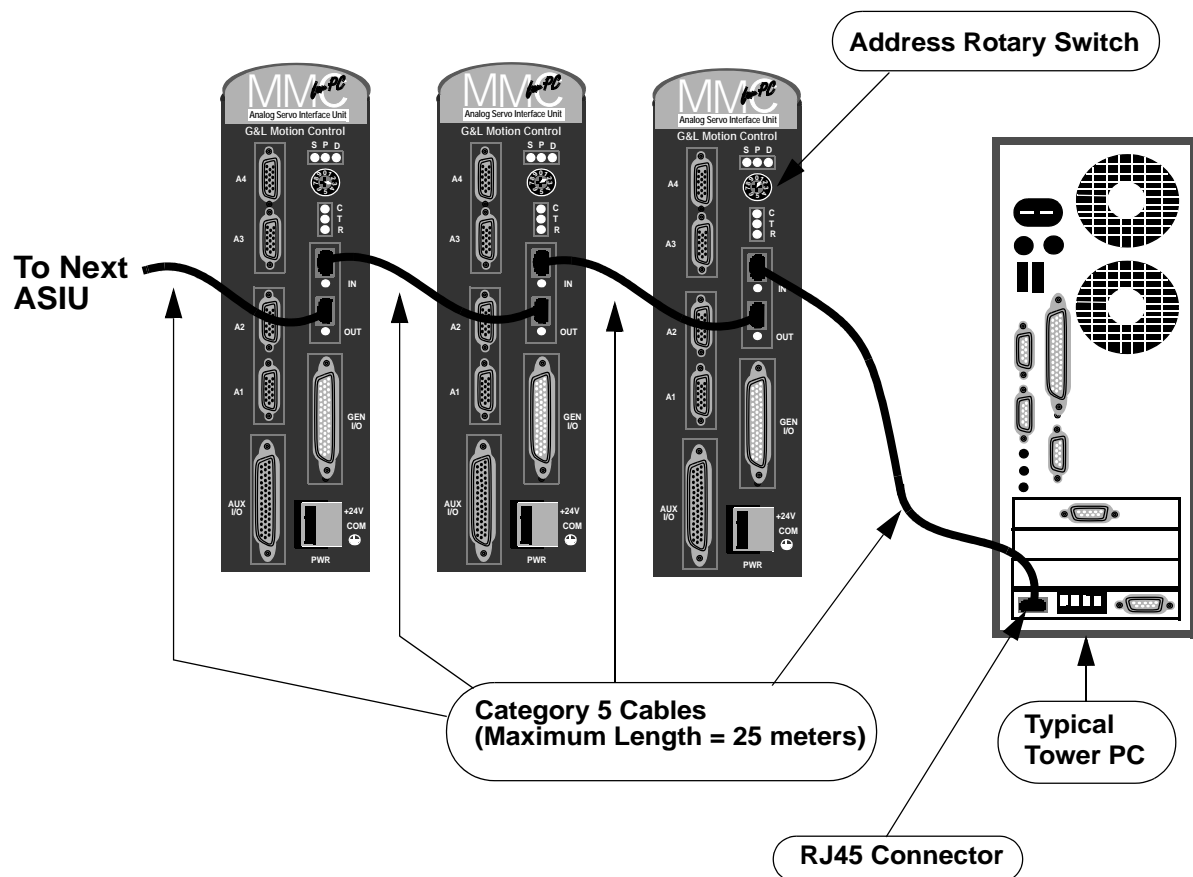

To be recognized by the MMC for PC Analog Board, each ASIU's rotary switch must be set to a unique number of 1 through 8. The switch setting corresponds to that ASIUs setting in PiCPro. ASIU switch values can be random with respect to their physical location in the chain of ASIUs but no two can have the same switch setting. A setting of 0 or 9 effectively removes the ASIU from the system but does not affect communication to other ASIUs in the system.

7.4 Troubleshooting the MMC for PC Battery

If the scan display on the PC does not display RUN and the battery on the MMC for PC board is not good:

Change the battery.

1. Make sure that the board has been powered up for at least five minutes. This ensures that the on-board capacitors will retain the memory for at least ten minutes while the battery is being replaced.
2. Turn off system main disconnect (which should also turn off all external power supplies to the application).
3. Unplug the external DC power to the MMC for PC board.
4. Remove the coin cell battery from the MMC for PC board.
5. Install a new battery into the MMC for PC board. The battery type is a BR2330.

If the battery is changed, the battery display indicates the battery is good, and the scan display still does not display RUN, do the following:

1. Shut down the Windows system and turn off the computer and all auxiliary equipment.
2. Turn off power to the computer system and to the application.
3. Turn off the main disconnect (which should also turn off all external power supplies to the application).
4. Unplug the DC power to the MMC for PC.
5. If the I/O wiring is connected, remove the connector.
6. Remove the defective MMC for PC board from the computer.
7. Replace with a new MMC for PC board. Connect the I/O wiring.
8. Turn on power to check diagnostics again and make sure there are no more hardware errors.
9. If an application program is not in system memory, use the download hex command in the PiCPro software to place it there.

NOTES

8 Connections to External Devices

8.1 Connections to External Devices - MMC for PC

All connectors for the MMC for PC board are located on the mounting bracket at the rear of the board. This bracket and connection points are accessible from the back of the user's PC.

G&L Motion Control also provides many optional accessories that simplify wiring the MMC for PC to external devices. Consult G&L Motion Control for further information on how these accessories can be applied.

8.1.1 Optional External Power and Keyswitch Connections

The external power connection is optional. It is only needed if you want to keep the MMC for PC running when the host PC is shut down. It is used to disable PiCPro communication to the MMC for PC. This is done by connecting the +R pin to the -R pin. This does not disable the OPC Server or any other ladder Ethernet function.

The required external power supply for both the MMC for PC SERCOS and MMC for PC Analog system is +24 VDC. The power supply connection is made with a 4-pin plug type screw terminal connector.

The Keyswitch connection enables or disables the control of the MMC for PC by other PCs on a network. With the Keyswitch pin connected to +12 VDC, only one PC can control the MMC for PC over the network. With the Keyswitch open or tied to 0 volts, other PCs can control the MMC for PC over the network.

Table 9 shows the pinouts for the External Power Supply and Keyswitch connections. The pins are listed as they appear from top to bottom on the connector.

Table 9: Pinout for 4-pin External Power Supply and Keyswitch Connections

Pin	Description	In/Out
-R	Key Switch	In
+R	+12 VDC	Out
-V	24 VDC Common	In
+V	+24 VDC	In

8.1.2 Block I/O Port

The block I/O port provides up to 77 expansion block I/O units, 4-wire communication interface and up to 200 feet between block I/O units.

Type	MMC for PC Block I/O 9-Pin D-Sub Female Connector			Block I/O Communications Connector (In from MMC for PC)			
	Pin	Description	In/Out	Pin	Description	In/Out	
	1	NC					
	2	NC					
Twisted Pair	3	Transmit Data +	Out	to	1	Receiver +	In
	4	Transmit Data -	Out	to	2	Receiver -	In
Twisted Pair	5	Receive Data +	In	to	4	Driver +	Out
	6	Receive Data -	In	to	5	Driver -	Out
	7	Shield			3	Shield	
	8	NC					
	9	NC					

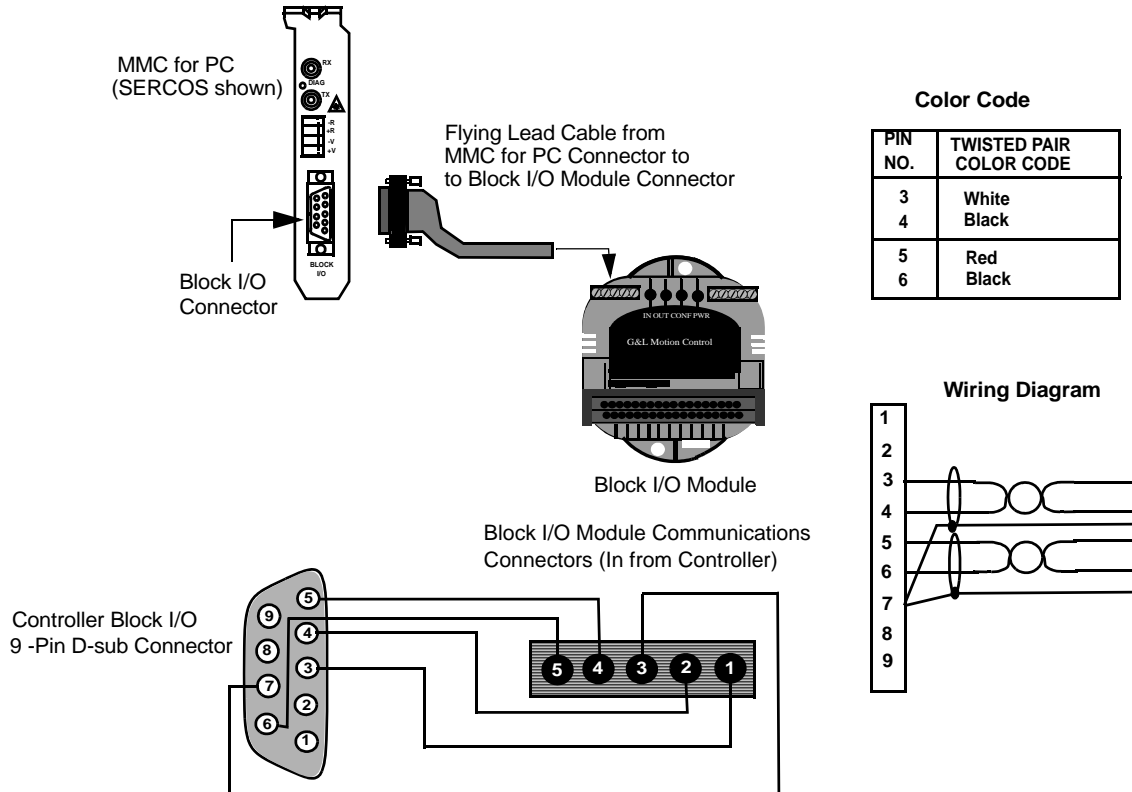

8.1.3 Motion Control Connections for MMC for PC SERCOS Board

8.1.3.1 SERCOS Receive and Transmit Ports

The SERCOS ports located at the back of the board can connect to one SERCOS ring. The connection to this ring is made through a pair of female fiber optic SMA connectors. The SERCOS board's transmitter is connected to the first receiver in the loop and the SERCOS board's receiver is connected to the last transmitter in the loop. Refer to Figure 15.

Figure 15: Location of SERCOS Board SERCOS Port

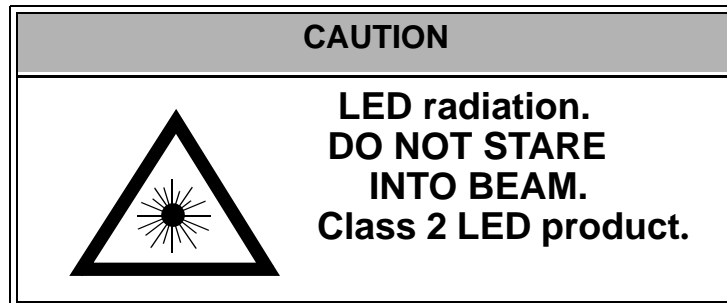
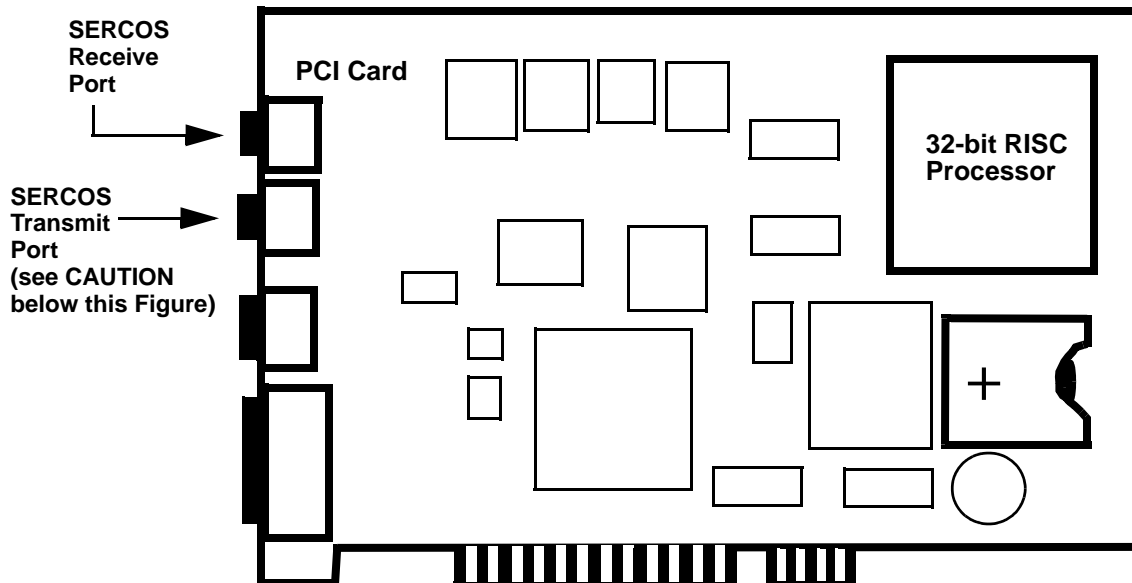

8.1.4 Motion Control Connections for MMC for PC Analog Servo Board

8.1.4.1 ASIU Connector

An Analog Servo Interface Unit (ASIU) supplies the I/O communication to the MMC for PC Analog Servo board. The ASIU is available in two models:

- ASIU-2 (2 1/2 axis analog servo unit)
- ASIU-4 (4 1/2 axis analog servo unit)

The MMC for PC board is connected to the ASIU by standard category 5 patch cables connected to the RJ-45 connectors. Refer to Figure 16.

The MMC for PC is connected to the first ASIU's "IN" port. The first ASIU's "OUT" port is connected to the second ASIU's "IN" port. The same "IN/OUT" connections are made for additional ASIUs.

Figure 16: Location of Analog Servo Board ASIU RJ45 Connector

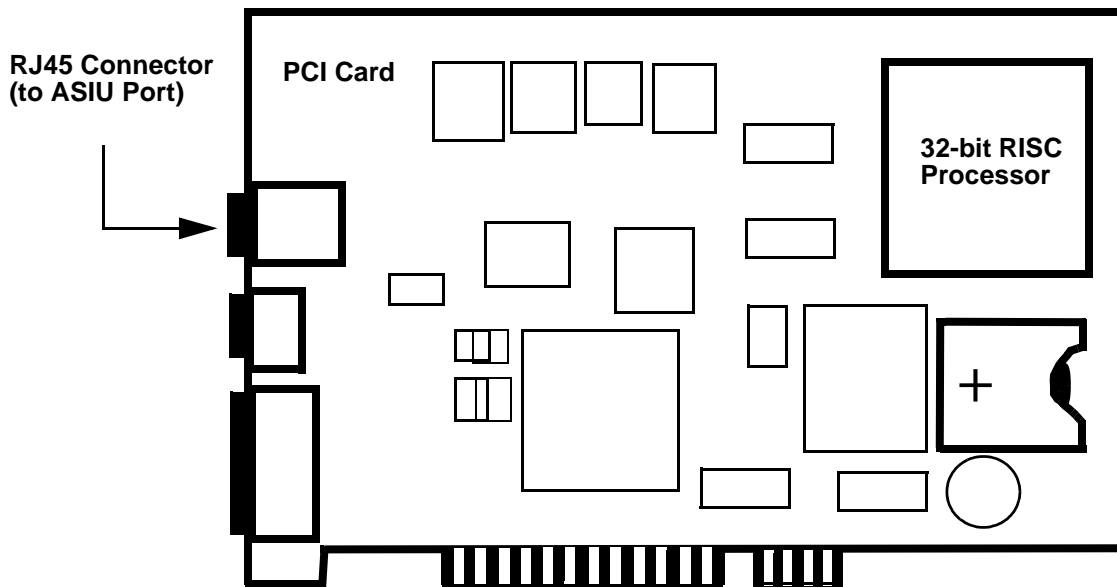

8.2 Connections to External Devices - ASIU

G&L Motion Control provides many optional accessories that simplify wiring the ASIU to external devices. These accessories include cables to connect the ASIU to G&L Motion Control's line of DSM and Micro DSM drives and breakout boxes that provide screw-terminal connections to the ASIU. Consult the factory for further information.

8.2.1 General I/O Port

Refer to Table 10. The general I/O port includes:

- 16-24 VDC inputs
 - Sink or source in groups of eight
- +24 VDC and 24 V Common
- 16-24 VDC outputs
 - Source only
 - 250 mA output capacity
 - Short circuit protected
- A control relay to de-energize outputs without affecting other ASIU functions

Table 10: Pinout for ASIU General I/O Port

Pin	Description	In/Out	Pin	Description	In/Out	Pin	Description	In/Out
1	DCOUT1	Out	16	DCOUT16	Out	31	NC	
2	DCOUT2	Out	17	NC		32	NC	
3	DCOUT3	Out	18	OUTEN	In	33	NC	
4	DCOUT4	Out	19	IO24V	Out	34	IO24V	Out
5	DCOUT5	Out	20	IO24V	Out	35	DCSS2	In
6	DCOUT6	Out	21	DCSS1	In	36	IO24C	Out
7	DCOUT7	Out	22	IO24C	Out	37	DCIN9	In
8	DCOUT8	Out	23	DCIN1	In	38	DCIN10	In
9	DCOUT9	Out	24	DCIN2	In	39	DCIN11	In
10	DCOUT10	Out	25	DCIN3	In	40	DCIN12	In
11	DCOUT11	Out	26	DCIN4	In	41	DCIN13	In
12	DCOUT12	Out	27	DCIN5	In	42	DCIN14	In
13	DCOUT13	Out	28	DCIN6	In	43	DCIN15	In
14	DCOUT14	Out	29	DCIN7	In	44	DCIN16	In
15	DCOUT15	Out	30	DCIN8	In			

There are 16 outputs on the General I/O connector. These outputs get their power internally from the ASIU. These outputs will not energize unless the control relay internal to the ASIU is activated and the scanning Ladder is turning the outputs on. Refer to Figure 17.

Figure 17: General Outputs Connected to Loads - ASIU

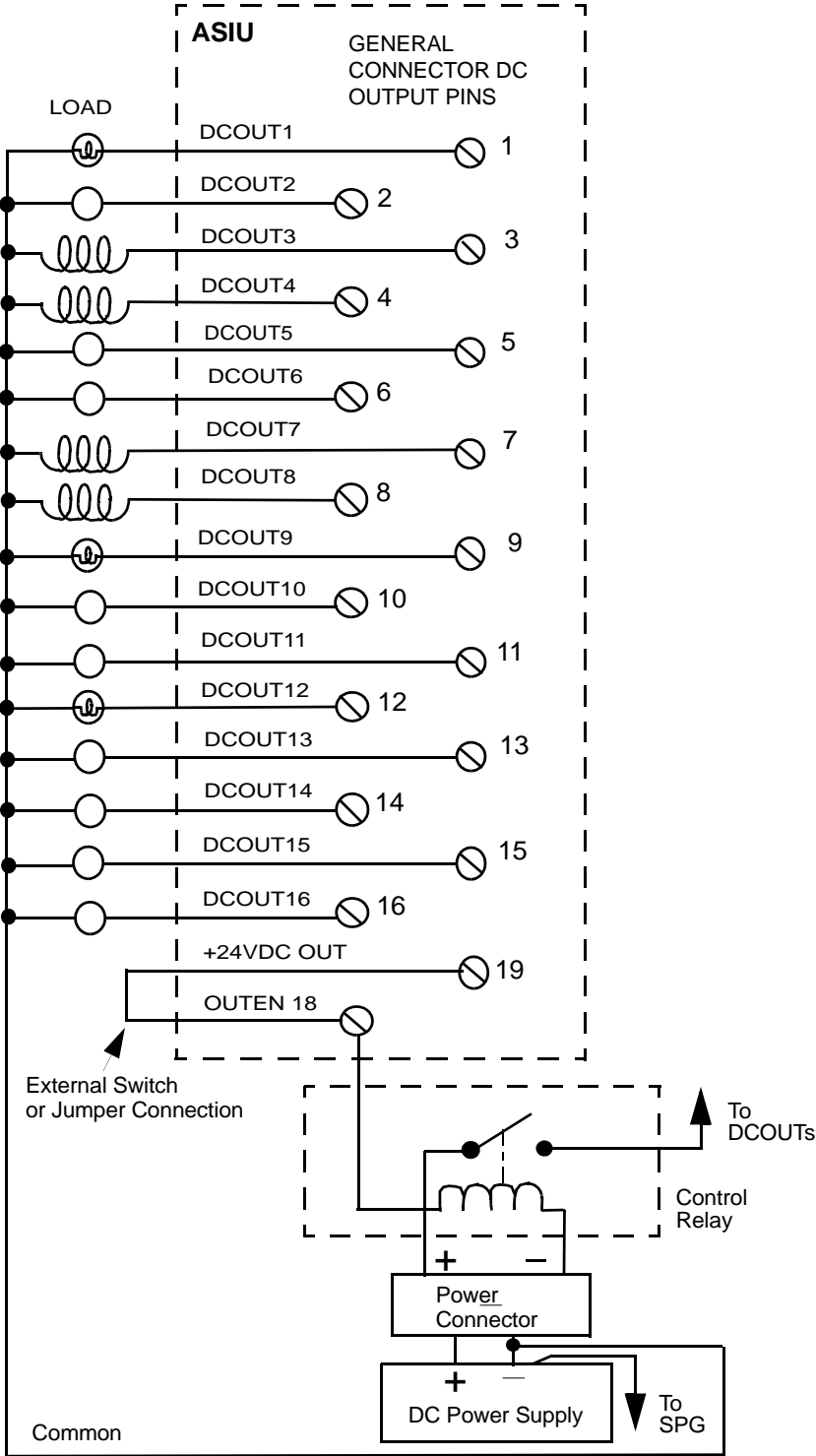

There are 16 general inputs on the general connector. The inputs are configured as two groups of eight. Each group can be configured as sourcing or sinking. Connect the DCSS pin to +24 V for a sinking configuration. Connect the DCSS pin to COM for a sourcing configuration. You can use the internal +24 V supply as shown in Figure 18.

Figure 18: ASIU Sink/Source General Input Configuration

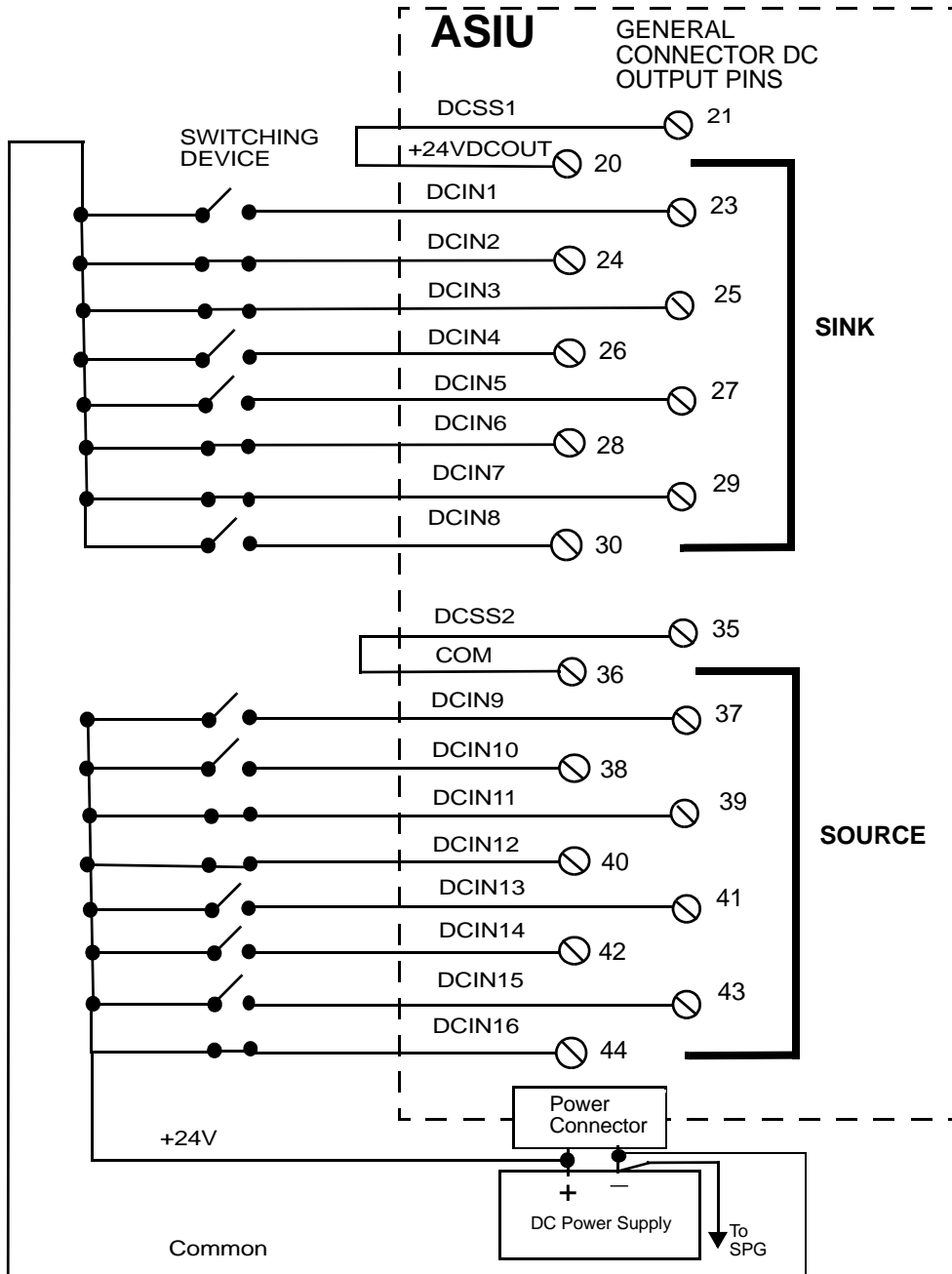

8.2.2 Power Connection

You must provide a +24 VDC power supply as the power source for the ASIU. The power supply screw terminal connection (3 pin) is at the bottom of the CPU section of the ASIU. Figure 19 illustrates the pin-out for the power supply.

Figure 19: Pin Out for the 3-pin Power Supply Screw Terminal Connection

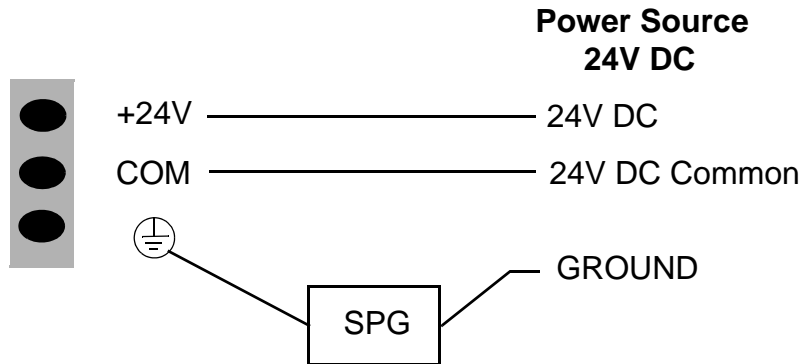

The 24 VDC applied at the ASIU input power connector also appears as an output at several points on the ASIU connectors to power the:

- devices connected to the AXIS connectors
- devices connected to the AUX I/O connector
- input devices connected to the GEN I/O connector
- axes interface

8.2.3 Axis Connectors

There are either two (ASIU-2) or four (ASIU-A4) Axis connectors.

Each axis has its own 15 pin high density D connector. Each axis connector provides the following signal connections:

- One 16-bit resolution analog output (± 10 VDC)
- One quadrature, incremental encoder input
- Two DC outputs (24 VDC sink or source)
- One DC input (24 VDC sink or source)
- +24 VDC output

These signals are typically connected to the drive as shown in Table 11.

Table 11: ASIU Axis Connector - Signal Connections

ASIU Axis Signal	Connection
Analog output	Drive command
Encoder input	Drive encoder output
DC output 1	Drive enable input
DC output 2	Drive reset input
DC input 1	Drive fault output
DCOSS	+24V or COMMON (on ASIU)

The axis connector pinout is listed in Table 12.

Table 12: ASIU Axis Connector Pinout

Pin	Description	Pin	Description
1	A	9	DA-
2	A/	10	I/
3	B	11	+24 VDC out
4	B/	12	COM
5	I	13	DCOUT1
6	DCIN+	14	DCOUT2
7	DCIN-	15	DCOSS
8	DA+		

The metal shell of the 15-pin connector is tied to the chassis ground terminal on the ASIU power connector. Cables provided by G&L Motion Control will have the shield connected to the metal shell of the cable connector. If you use other cables, be sure to connect the shield to the metal shell of the connector.

The DC outputs can be configured for either sink or source operation. When the DCOSS pin is tied to the +24V, the outputs will be in a source configuration as shown in Figure 20.

Figure 20: ASIU Source Configuration

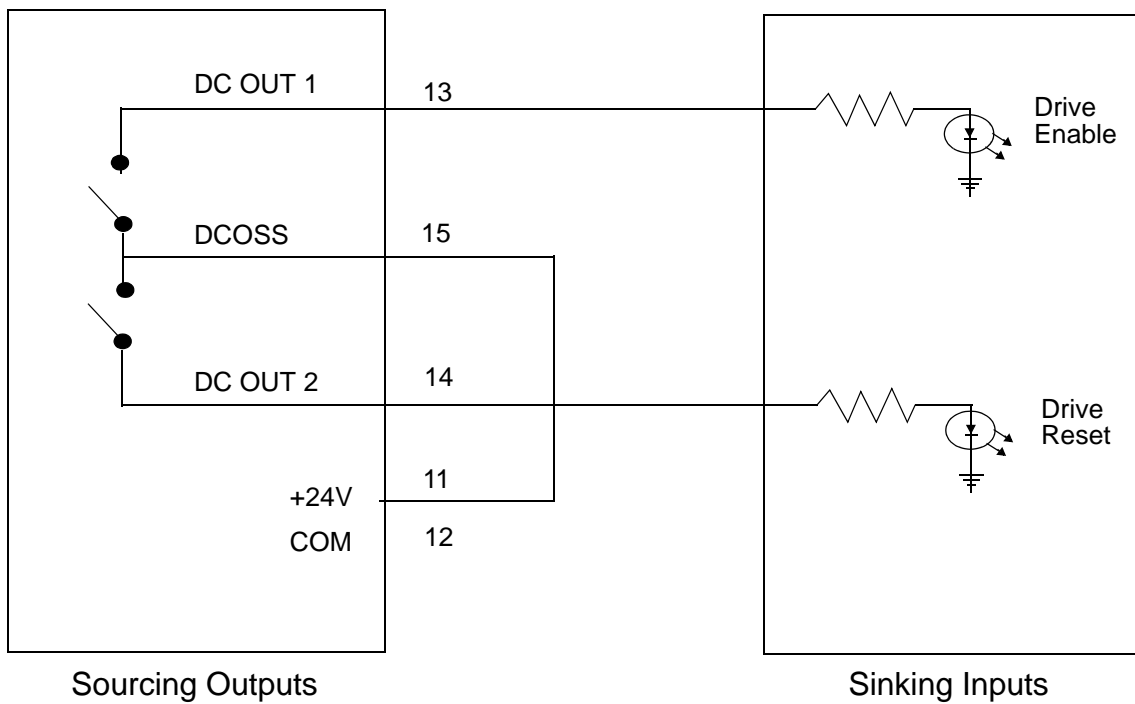

When the DCOSS pin is tied to COMMON, the outputs will be in a sink configuration as shown in Figure 21.

Figure 21: ASIU Sink Configuration

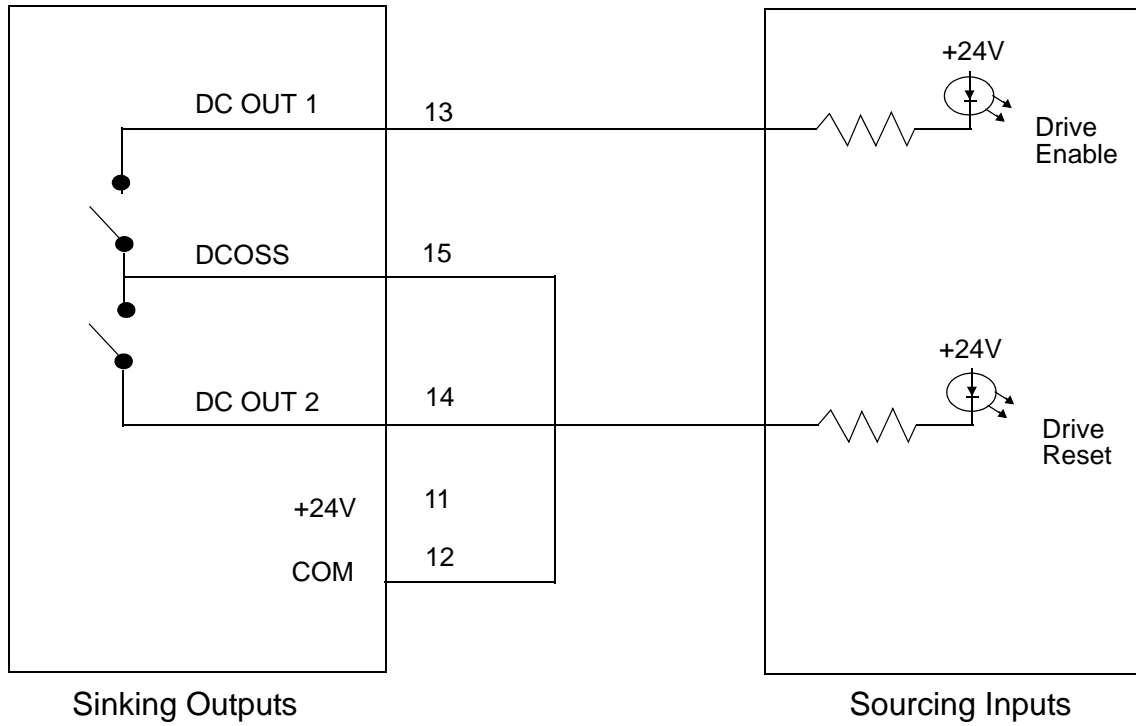

The analog output is connected to the drive command input. Twisted pair wire should be used to make the connection between the analog output and the drive as shown in Figure 22.

Figure 22: ASIU Axis Analog Output Connected to Drive Command Input

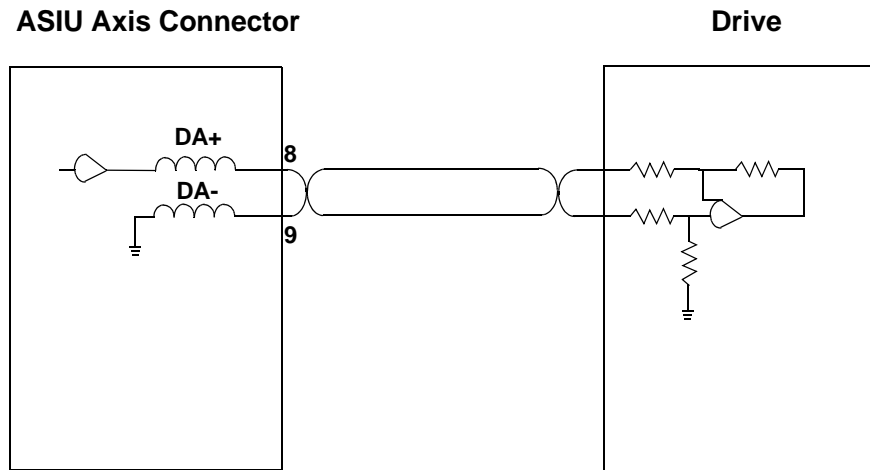

Drives will typically have an output signal indicating that the drive is operational. This "drive ready" signal can be connected to the Axis DC Input. One of the input pins should be connected to either +24 V or COM. The remaining input pin should be tied to the input signal that will be switching. Refer to Figure 23.

Figure 23: ASIU Axis DC Input Connected to Drive Ready

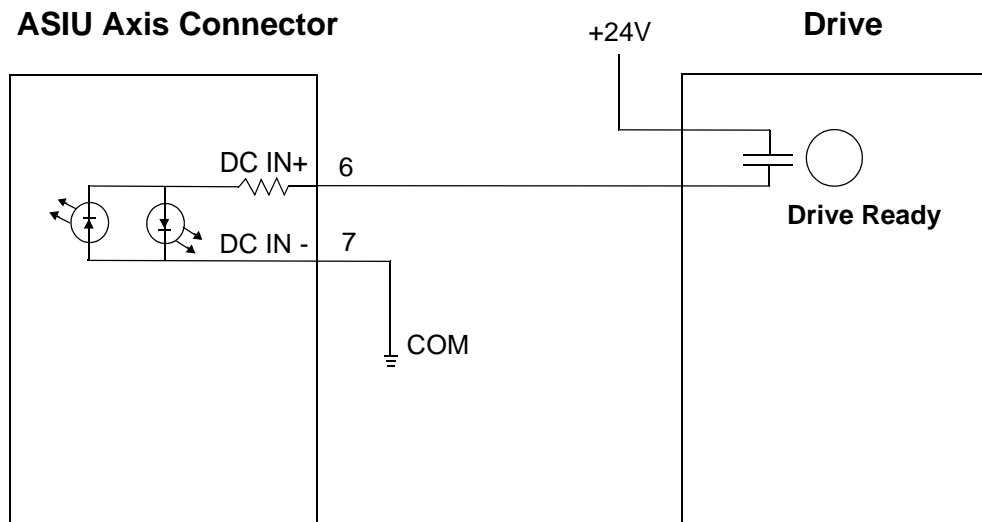

The encoder output signals from the drive should be connected to the encoder input on each axis. The ASIU analog section accepts RS422 level differential inputs. The encoder signals should be quadrature type. All encoder wiring between the ASIU and the drive should be twisted pair.

Figure 24: ASIU Encoder Inputs Connected to Drive Encoder Outputs

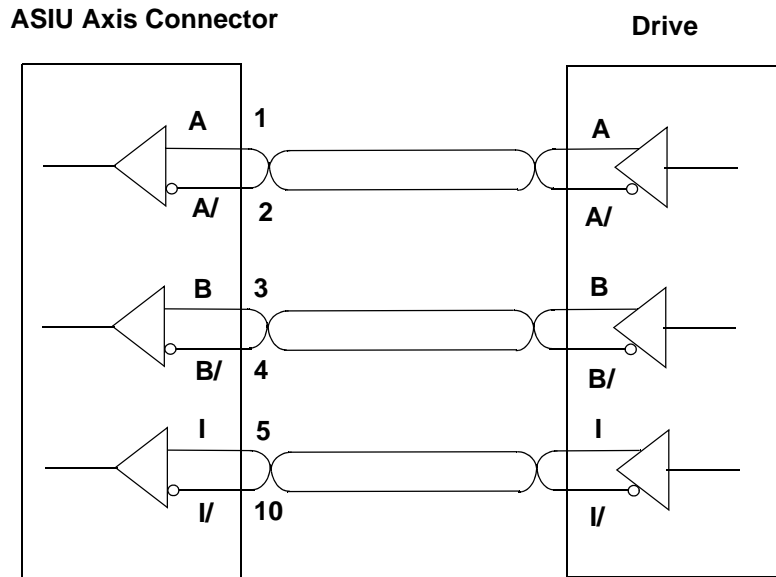

8.2.4 Auxiliary I/O Connector

There is one 44-pin AUX I/O connector on the ASIU. It provides the following inputs:

- One quadrature, incremental encoder channel (1 Mhz frequency, RS422 interface)
- Five fast DC inputs (one per encoder input) for high speed position latching)
- One 12-bit resolution analog input channel
- 12 optically isolated DC inputs (6 on the ASIU-A2)
- +24 VDC output
- +5 VDC output
- Seven Shield connections

The auxiliary I/O connector pinout for the ASIU-A4 (4 axes) is listed in Table 13.

Table 13: ASIU-A4 Auxiliary I/O Connector

Pin	Description	Pin	Description	Pin	Description
1	A	16	FASTIN1+	31	DCSSA
2	A/	17	FASTIN1-	32	DCIN1
3	B	18	SHIELD	33	DCIN2
4	B/	19	FASTIN2+	34	DCIN3
5	I	20	FASTIN2-	35	DCIN4
6	I/	21	SHIELD	36	DCIN5
7	SHIELD	22	FASTIN3+	37	DCIN6
8	+24 VDC out	23	FASTIN3-	38	DCSSB
9	+24 VDC out	24	SHIELD	39	DCIN7
10	COM	25	FASTIN4+	40	DCIN8
11	COM	26	FASTIN4-	41	DCIN9
12	+5 VDC out	27	SHIELD	42	DCIN10
13	ANLGIN+	28	FASTIN5+	43	DCIN11
14	ANLGIN-	29	FASTIN5-	44	DCIN12
15	SHIELD	30	SHIELD		

The auxiliary I/O connector pinout for the ASIU-A2 (2 axes) is listed in Table 14.

Table 14: ASIU-A2 Auxiliary I/O Connector

Pin	Description	Pin	Description	Pin	Description
1	A	16	FASTIN1+	31	DCSSA
2	A/	17	FASTIN1-	32	DCIN1
3	B	18	SHIELD	33	DCIN2
4	B/	19	FASTIN2+	34	DCIN3
5	I	20	FASTIN2-	35	DCIN4
6	I/	21	SHIELD	36	DCIN5
7	SHIELD	22	NC	37	DCIN6
8	+24 VDC out	23	NC	38	NC
9	+24 VDC out	24	SHIELD	39	NC
10	COM	25	NC	40	NC
11	COM	26	NC	41	NC
12	+5 VDC out	27	SHIELD	42	NC
13	ANLGIN+	28	FASTIN5+	43	NC
14	ANLGIN-	29	FASTIN5-	44	NC
15	SHIELD	30	SHIELD		

NOTE

The encoder input on the auxiliary connector is identical to the encoder inputs on the axis connectors. See Figure 24.

Each encoder channel has a fast DC input associated with it. The fast input can be used to latch the encoder position. Shielded twisted pair wiring should be used for all fast input connections. The fast inputs can be connected in either a source or sink configuration. The source configuration is illustrated in Figure 25.

Figure 25: ASIU Fast Inputs Connected Using Shielded Twisted Pair (Source)

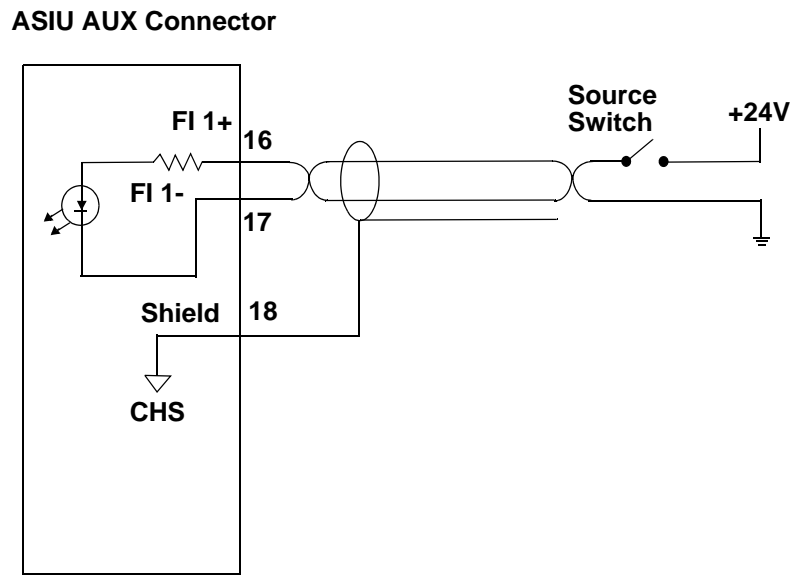

The ASIU fast input sink configuration is illustrated in Figure 26.

Figure 26: Fast Inputs Connected Using Shielded Twisted Pair (Sink)

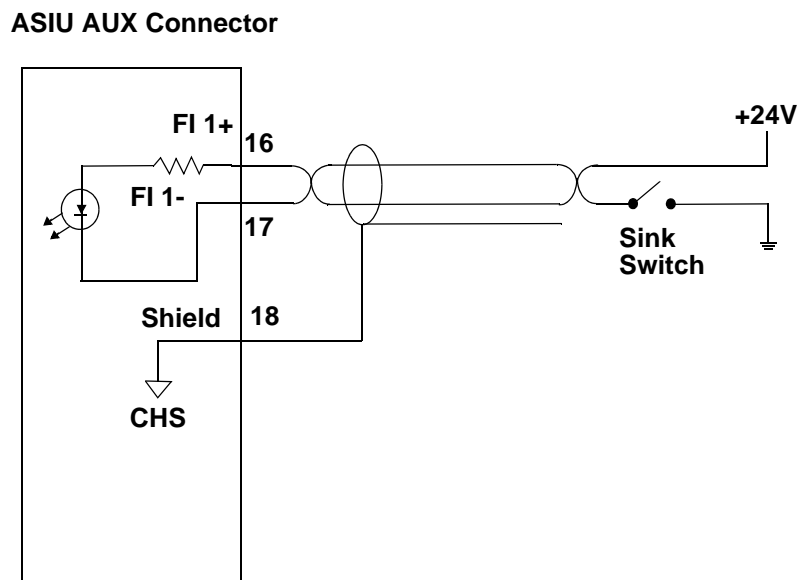

There are either 6 (ASIU-2) or 12 (ASIU-4) general purpose inputs on the auxiliary connector. The inputs are configured as one group of 6 for the ASIU-A2 or two groups of 6 for the ASIU-A4. Each group can be configured as sourcing or sinking. Connect the DCSS pin to +24 V for a sinking configuration. Connect the DCSS pin to COM for a sourcing configuration. You can use the internal +24 V supply as shown in Figure 27. See Table 13 and Table 14 for those connections.

Figure 27: ASIU Sink/Source Connections using Internal +24 V Supply

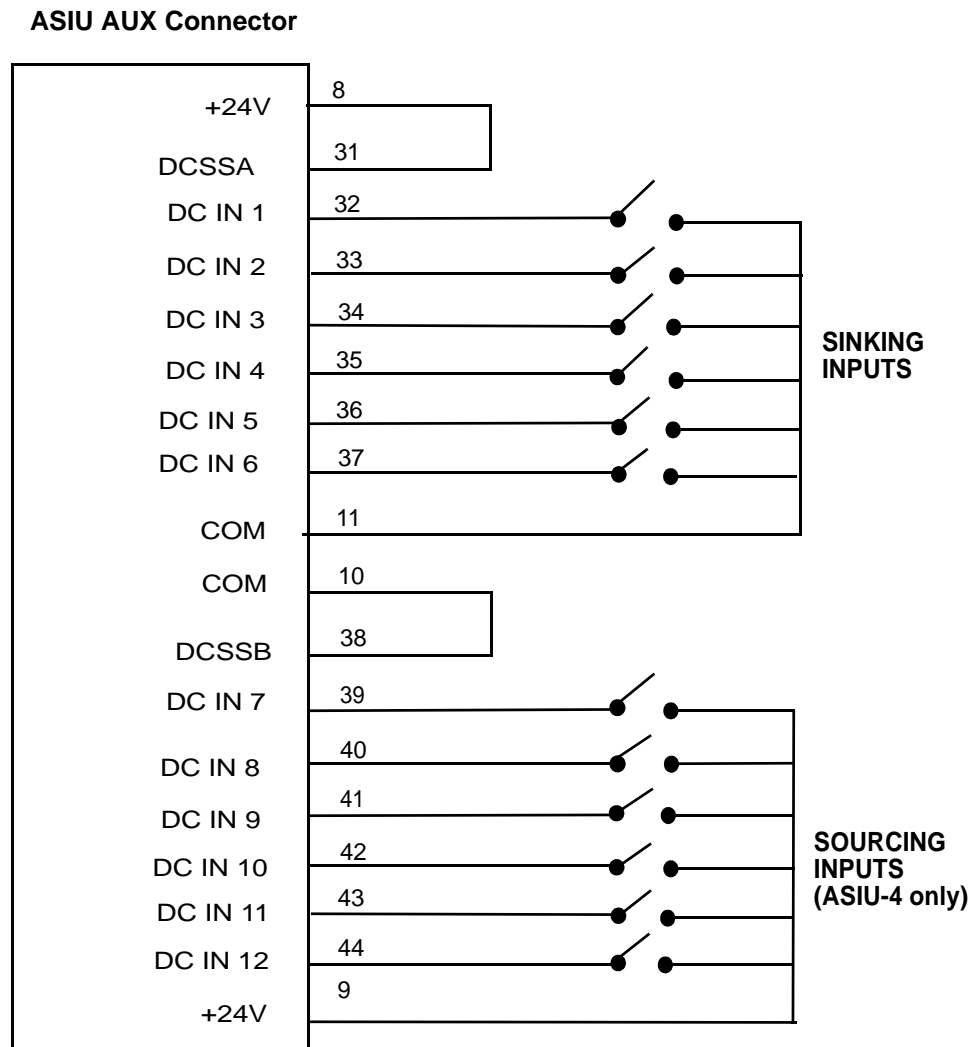

Or you can use an external +24 V supply as shown in Figure 28.

Figure 28: ASIU Sink/Source Connections using External DC Supply

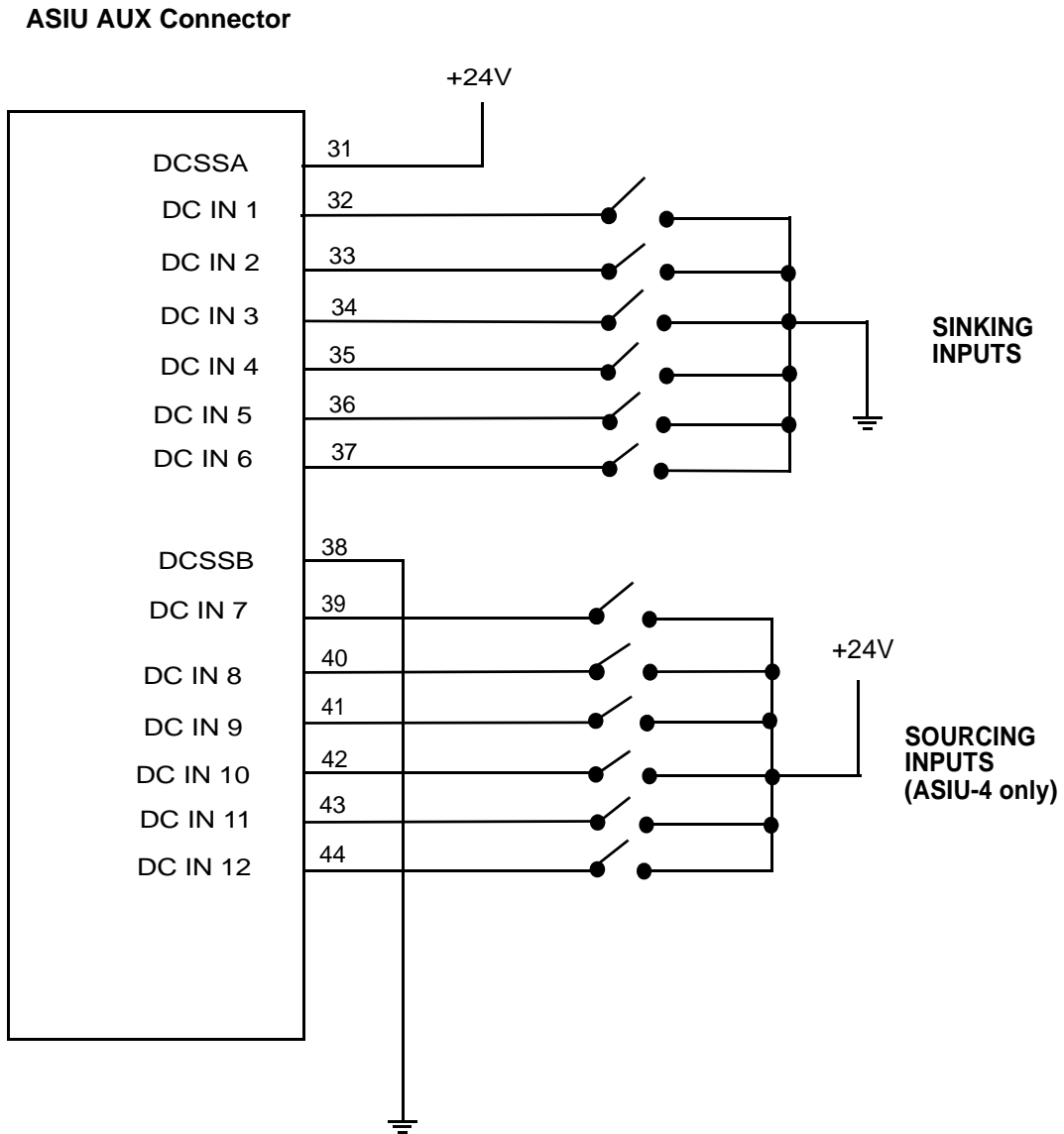

9 MMC for PC Diagnostics

Good procedure suggests that the system should be tested each time a new application is powered up and checked regularly while running.

This section applies to both power-on and run-time diagnostics.

When the system is started, it tests itself and reports the results of the tests in the **Diagnostic** display that appears in an MMC for PC Status Dialog Box as shown in Figure 30.

This dialog box is accessed by clicking on the MMC for PC Status icon that is located in the lower right hand corner of the Windows 2000 or NT taskbar (near the Time icon). Refer to Figure 29.

Figure 29: Location of MMC for PC Status Icon

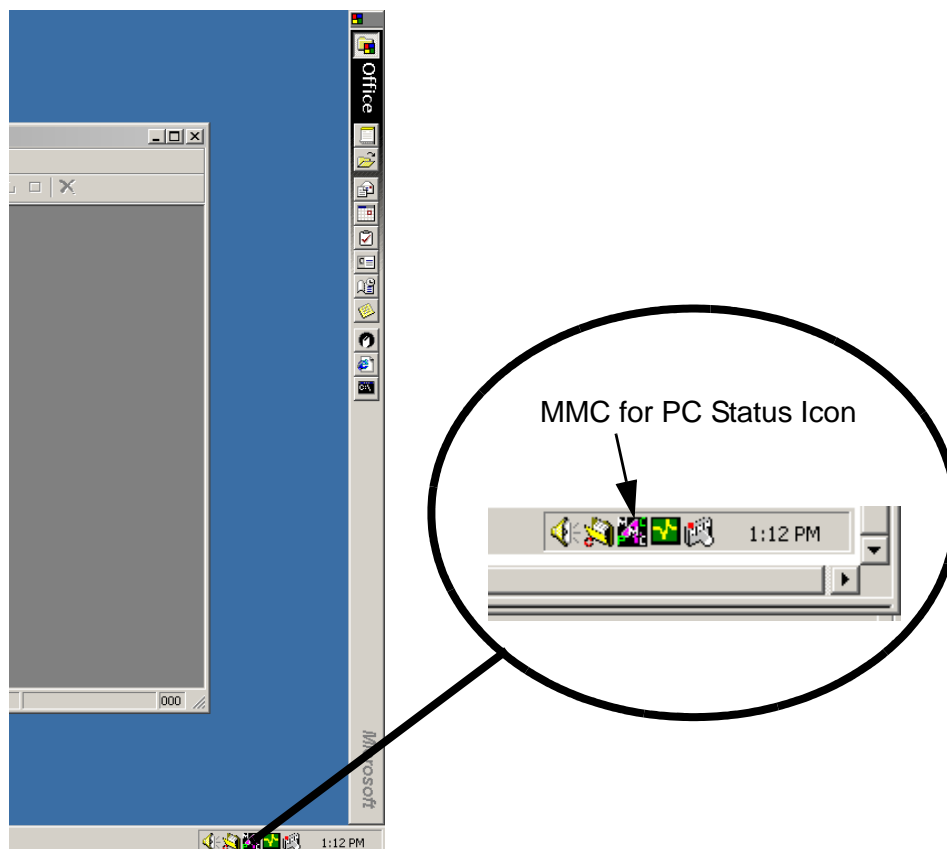
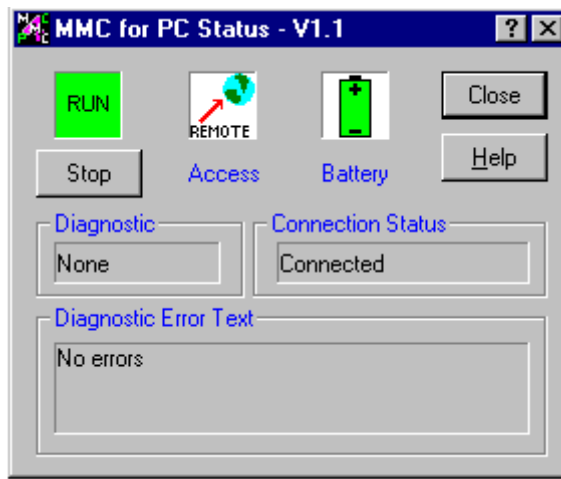

Figure 30: MMC for PC Status Dialog Box**NOTE**

The MMC for PC Status Dialog Box does not terminate when the "Close" or "X" buttons are clicked. This dialog box remains as an icon in the status area of the Windows desktop. This dialog box can be terminated and the status icon can be removed from the Windows desktop by using the task manager.

If the MMC for PC Status Dialog Box is terminated and its icon is removed from the Windows desktop, it can be restarted from the Windows "Start" menu under "Startup" by selecting MMC Status.

9.1 Description of MMC for PC Diagnostic Symbols

9.1.1 Scan

The current status is displayed as one of the following:

- **The start-up diagnostics are complete with no errors and the MMC for PC is scanning.**



- **The MMC for PC is not scanning.**



9.1.2 Access

The current control connection status is displayed as:

LOCAL - This display indicates the local programmer access state and that PicPro must be run from the PC that contains the MMC for PC board.



REMOTE - This display indicates the remote programmer access state and that a version of PicPro other than the PC containing the MMC for PC can connect to the MMC for PC.



9.1.3 Battery

The current operating status of the board's battery is displayed as:

Green - This display indicates the battery charge is good.



Red - This display indicates the battery charge is not good and the battery needs to be replaced



9.1.4 Diagnostic

This display indicates the system has passed diagnostic testing and is ready to run or that there is system error.

If a number is shown it indicates the diagnostic error value from the MMC for PC control system (the example shows the text when no errors are present).

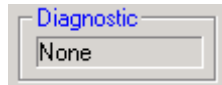

9.1.5 Diagnostic Error Text

This display contains text that describes the diagnostic number shown in the Diagnostic display (the example shows the text when no errors are present).

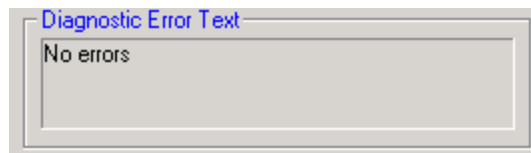

9.1.6 Connection Status

This display indicates the connection status of the application to a Windows NT socket server.

The display will toggle from **Trying to Connect** to **Not Connected** while the MMC for PC Status application is trying to connect or if the connection is lost. Possible displays are as follows:

Trying to connect - indicates the MMC for PC Status application is trying to connect to the server.

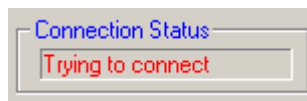

Connected - indicates the MMC for PC Status application is connected to the server.



Not connected - indicates the MMC for PC Status application's attempt to connect to the server has failed. The icon on the MMC for PC status bar will blink if communications are broken with the MMC for PC or if a diagnostic error exists.

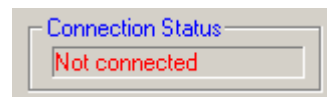

9.1.7 Status Unknown



This display indicates that the operating status is unknown.

It will appear in the Scan, Access and Battery displays at the same time when there is a communication failure as follows:



The question marks indicate that the status of the scan, access and battery are unknown. The text in the diagnostic, connection status and diagnostic error text change color (red for a problem, black if OK, yellow if it is the last state but may not be correct because of the loss of communication with the MMC for PC control).

NOTES

10 ASIU Diagnostics

If the system has completed start-up properly, the DIAG LED on the ASIU should be off indicating that the diagnostic tests were passed.

This section covers two types of diagnostics for the ASIU; power-on and run-time.

10.1 Power-On Diagnostics

When the system is powered up, the MMC for PC Analog Board tests connected ASIUs and reports the results of the tests in the form of LED signals.

10.1.1 Power LED

If the power light (P) does not go on, or goes off during operation of the system, check that power is still connected to the ASIU. If it is, turn off the main disconnect switch and replace the ASIU.

10.1.2 Scan LED

If the SCAN LED does not go on:

1. Check that the power (P) light is ON.
2. Check that the diagnostic (D) light is OFF.
3. Check that the MMC for PC Analog Board is scanning.

10.1.3 Diagnostic LEDs

The ASIU has an LED marked D which lights up briefly while its diagnostic tests are running and then goes off. If the DIAG LED remains on, the ASIU has failed one of its tests. Follow these steps:

1. Turn off power to the system and to the application.
2. If the I/O wiring is connected, remove the connector .
3. Remove the defective ASIU from the system
4. Replace with a new ASIU. Connect the I/O wiring.
5. Turn on power to check diagnostics again.

NOTE

Diagnostics are run only when the system is powered up. It is possible that a failure might occur during operation. If so, the ASIU's DIAG light remains off. If you suspect that a module might be defective, cycle power to run diagnostics again.

10.2 Run-Time Diagnostics

While the ASIU is running, other tests are performed on a regular basis with their results also reported by LEDs as described in section 12.3 on page 85.

11 Troubleshooting the MMC for PC Battery

If the scan display on the PC does not display RUN and the battery on the MMC for PC board is not good:

Change the battery by doing the following:

1. Make sure that the board has been powered up for at least five minutes. This ensures that the on-board capacitors will retain the memory for at least ten minutes while the battery is being replaced.
2. Turn off system main disconnect (which should also turn off all external power supplies to the application).
3. Unplug the external DC power to the MMC for PC board.
4. Remove the coin cell battery from the MMC for PC board.
5. Install a new battery into the MMC for PC board. The battery type is a BR2330.

If the battery is changed, the battery display indicates the battery is good, and the scan display still does not display RUN, do the following:

1. Shut down the Windows system and turn off the computer and all auxiliary equipment.
2. Turn off power to the computer system and to the application.
3. Turn off the main disconnect (which should also turn off all external power supplies to the application).
4. Unplug the DC power to the MMC for PC.
5. If the I/O wiring is connected, remove the connector.
6. Remove the defective MMC for PC board from the computer.
7. Replace with a new MMC for PC board. Connect the I/O wiring.
8. Turn on power to check diagnostics again and make sure there are no more hardware errors.
9. If an application program is not in system memory, use the download command in the PiCPro software to place it there.

NOTES

12 Operating the MMC for PC System

12.1 General Operation

PiCPro is the software package that allows you to program and run your application(s) in the MMC for PC System. It includes the following programs:

Program	Function
Ladder Diagram	Allows you to program a ladder and save it as an .LDO file
Servo Setup	Allows you to program setup information for your servo application and save it as a .SRV file
SERCOS Setup	Allows you to program setup information for your SERCOS application and save it as a .SRC file
Project	Allows you to manage an application through development and production phases and then maintain the application

Refer to the PiC Pro Online Help for in-depth information and detailed instructions on operating the MMC for PC software.

12.2 ASIU Operation

Figure 31: ASIU Components

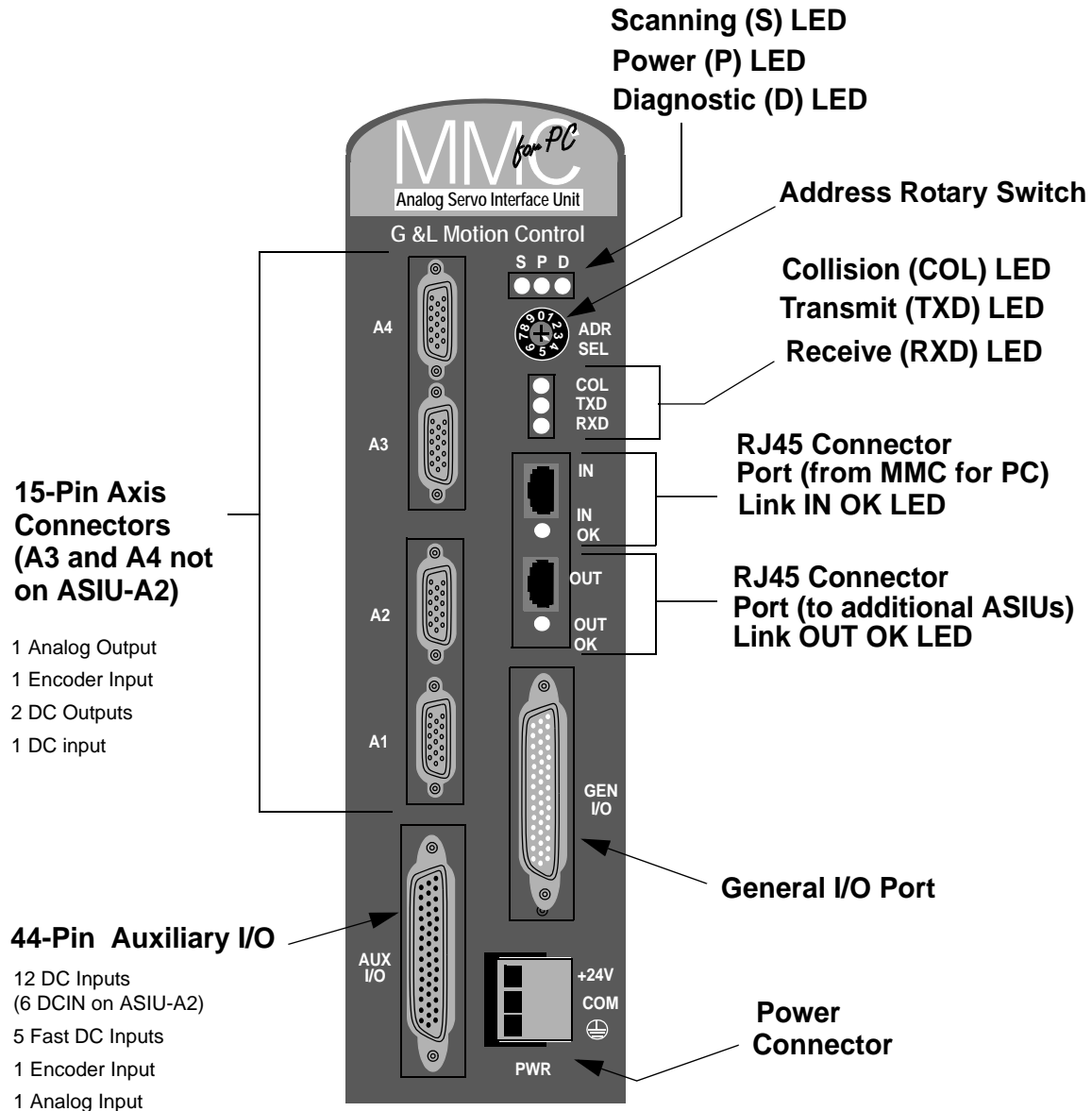

12.3 LEDs

There are three sets of LEDs on the top of the ASIU. Below is a list of the LEDs and their associated function. Refer to Figure 32 for the top set of LEDs, Figure 33 for the second set of LEDs and Figure 34 for the RJ45 Connector LEDs.

Figure 32: Top Set of ASIU LEDs with Functions

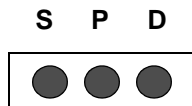

Scan (S) Green	
ON	Indicates the MMC for PC Analog Board is scanning a ladder and communicating with the ASIU.
OFF	Scan is lost and there is an orderly shut down procedure followed.
Power (P) Green	
ON	Power is on to the system. It indicates that the on-board +5 VDC supply is within tolerance.
OFF	Power is off or the on-board +5VDC supply is not within tolerance.
Diagnostic (D) Yellow	
ON	On briefly during startup diagnostics. If it remains ON, module has failed startup diagnostics.
OFF	Normal operation.

Figure 33: Second Set of ASIU LEDs with Functions

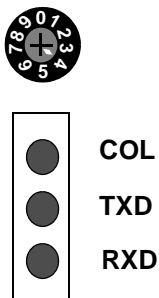

Collision(COL)Red	
ON	Indicates that two or more ASIUs are at the same address.
OFF	Normal operation
Transmit(TXD)Green	
ON	Indicates that the ASIU is sending a packet of information.
OFF	Indicates that the ASIU is not sending a packet of information.
Receive(RXD)Green	
ON	Indicates that the ASIU is receiving a packet of information.
OFF	Indicates that the ASIU is not receiving a packet of information.

Figure 34: ASIU RJ45 Connector LEDs with Functions

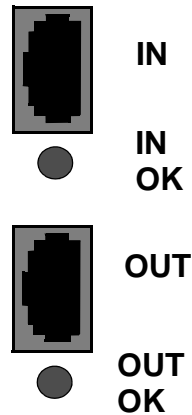

In Link OK(IN OK) Green	
ON	Indicates the IN RJ45 cable is wired correctly and that both ends are powered up.
BLINKING	Indicates that the ASIU is transmitting or receiving information.
OFF	Indicates the IN RJ45 cable is not wired correctly or that both ends are not powered up.
Out Link OK(OUT OK) Green	
ON	Indicates the OUT RJ45 cable is wired correctly and that both ends are powered up.
BLINKING	Indicates that the ASIU is transmitting or receiving information.
OFF	Indicates the OUT RJ45 cable is not wired correctly or that both ends are not powered up.

12.4 ASIU Output Theory of Operation (General I/O Connector)

Each of the 16 outputs on the general I/O connector is an optically isolated solid state switch rated at .250 A. The switch state is controlled by the ladder. When the ladder commands an output ON, the output supplies 24 VDC to the connected load. For safety reasons, all outputs turn off when a ladder scan loss occurs.

Power for the 16 General DC outputs is routed from the 3-pin power (PWR) connector located on the faceplate of the ASIU through the DC OUT control relay to the individual output switches. The control relay is controlled via a pin on the General I/O connector. Applying 24VDC to this pin energizes the relay thus enabling the General Outputs to be controlled by the ladder.

There are two groups of eight outputs: group A = output 1 through output 8, group B = output 9 through output 16. Each group is capable of detecting a short circuit condition. When a short circuit condition is sensed, all outputs in the group are turned off and remain off for approximately 100 ms regardless of ladder activity. After 100 ms, the ladder again controls the outputs. In addition, each output is protected with internal clamping diodes. Without clamping, high voltage transients (kickback) from inductive loads might damage the module.

12.5 Protecting from an Inductive Load

Resistive and inductive loads can be connected to the ASIU General outputs and controlled by the system with no precautions other than making sure they have a connection to the common of the DC power supply. Refer to Figure 35.

Inductive loads have an electrical "kickback" when current is stopped. This can damage or destroy the output switching device. Each output has a diode through which reverse current can be safely routed.

The internal diode works with an inductive load. When an output is energized, represented by a closed switch, current passes through the load into the common line. When the output is de-energized (by the ladder), represented by an open switch, current stops and the inductive field collapses. This creates a reverse voltage across the load called "kickback" which tries to continue the current. The voltage is in series with the DC power supply. The combined voltage appears across the output switching device in the module.

If this were the only path available, voltage across the device would peak at several hundred volts. The internal diode provides another path for current. This limits the peak reverse voltage across the load to less than 1 V. Every General output has this protection so you can connect an inductive load to any point.

Figure 35: Diagram of Internal Protection for Inductive Loads

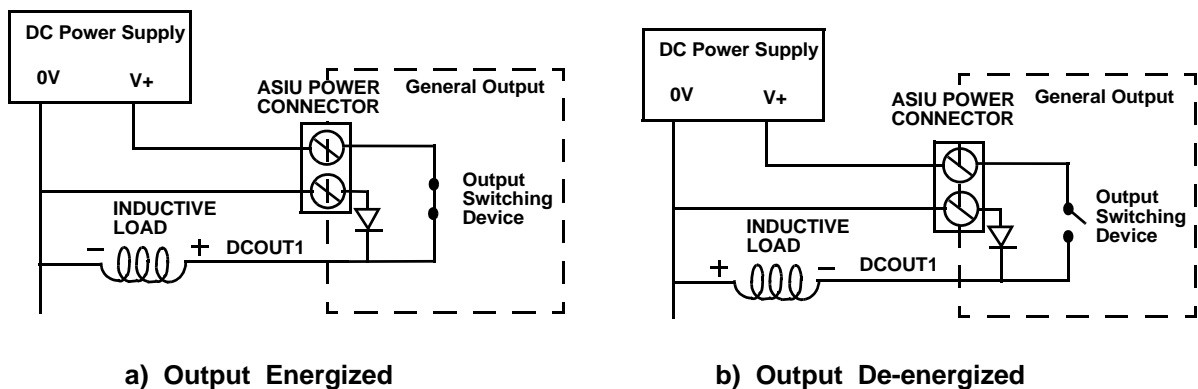

12.6 ASIU DC Output Theory of Operation (Axis Connector)

Each axis output is an optically isolated solid state switch. The switch state is controlled by the ladder. When the switch turns on, current flows through the switch. When the switch turns off, current flow stops.

These outputs are intended to interface with the drive enable and drive reset inputs. When an output is turned on current can flow through the switch in either direction. This allows the outputs to be connected in a sink or source configuration.

For safety reasons, all outputs turn off (no current flow) when a scan loss condition occurs.

12.7 ASIU DC Input Operation (Axis, AUX, General Connectors)

The ASIU converts input power into DC power at voltages of + 5 V, + 15 V, and - 15 V and supplies them to the logic side of the system.

Each input is guaranteed "on" at 14 to 30 VDC and guaranteed "off" at 0 to 5 VDC; polarity doesn't matter. Its on/off state is converted to a corresponding logic 1 or 0. This logic state is transmitted through the system bus to the CPU module, where the processor uses it as data in the ladder program. The logic side of the input is optically isolated from the field side.

The shaded blocks in Figure 36 show the limits specified by the IEC. The lines show the maximum and minimum V/I of the inputs in this module. The voltage/current curve in this graph shows that the input module is well within the IEC Type 1 limits.

Figure 36: Input Characteristics Compared to IEC Standards

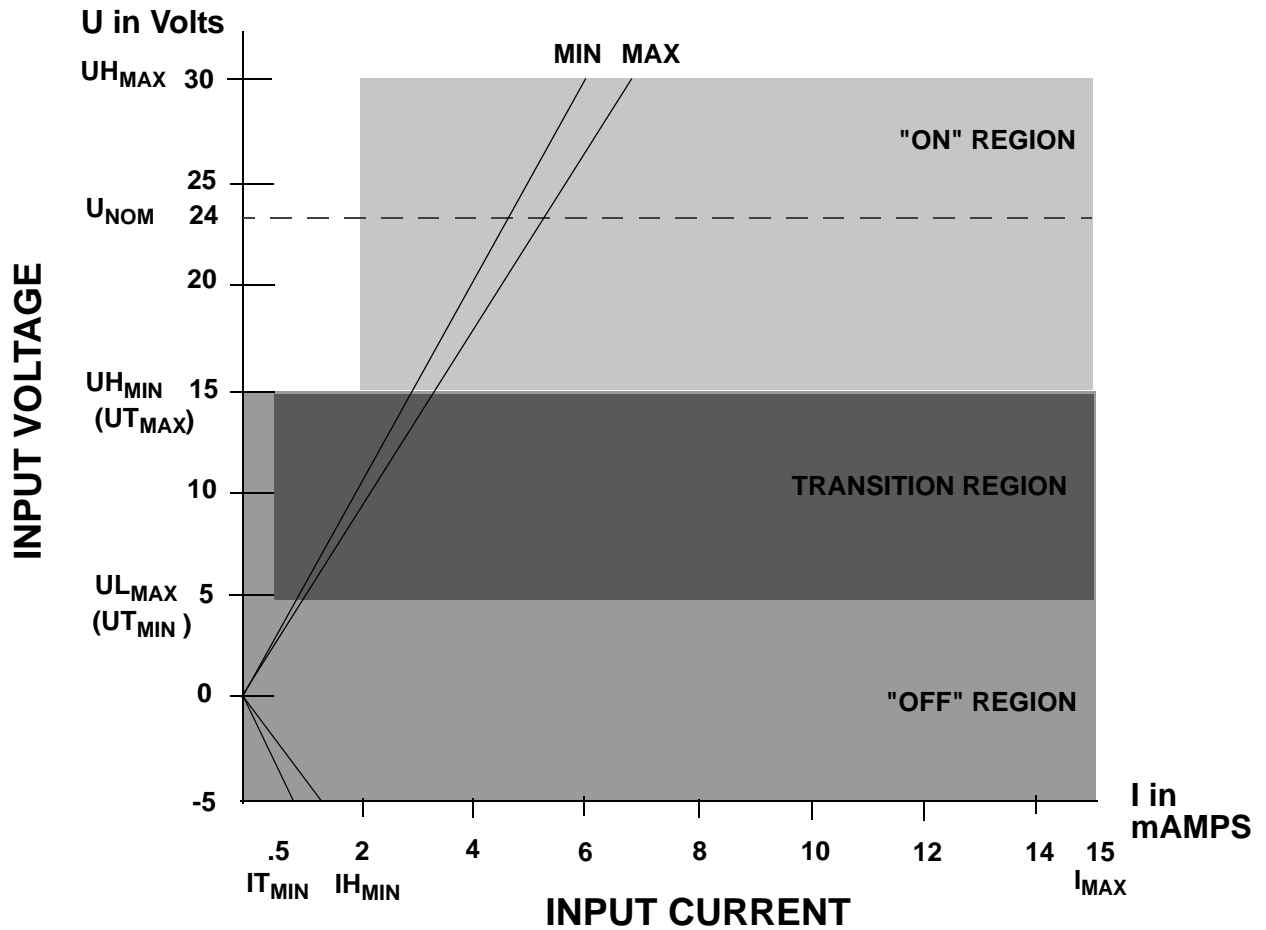

IMPORTANT

Switching devices can sometimes have a leakage current that exceeds the $I_{T_{min}}$ (current allowed when off) of an input module. In order to use such a device, an impedance (typically, a resistor) needs to be used in parallel with the input.

For example, some of the newer proximity switches use two wires instead of three. The third wire was used for a power or ground line. Without the third wire, the switch is easier to install. However, it requires more leakage current in the off state to power its internal circuitry.

As a conservative estimate, use the following formula to calculate an external resistance value. It keeps the input voltage at or below 2.4V when the switching device is in the "off" state.

$$\frac{2.4V}{\text{Switch Leakage} - 0.75mA} \geq R$$

If the switch leakage specification is ≤ 1.7 mA, then:

$$\frac{2.4V}{1.7 - 0.75mA} \geq 2.5K\Omega$$

Use a resistor less than or equal to 2.5 K Ω . Be sure that the wattage is adequate for the resistor when the switching device is in the "on" state remembering that:

$$P = \frac{V_{ON}^2}{R}$$

12.8 ASIU Analog Output Theory of Operation (Axis Connectors)

The ladder sends the analog output section a 16-bit digital word for each analog output channel used. Each digital word is converted to a corresponding voltage within the range of ± 10 V. The voltage is buffered and brought out to a pair of I/O connections as a differential type voltage output. This output is less subject to interference from electrical noise than a single-ended output would be.

You can adjust each analog output channel in software for offset adjustments, gain scaling, and unipolar outputs.

For safety reasons, all outputs are automatically reset to 0 V when a scan loss condition occurs.

12.9 ASIU Encoder Theory of Operation (Axis and AUX Connectors)

The encoder section uses differential type inputs to interface with up to five independent incremental encoders. These inputs accept RS422 level quadrature signals.

A *quadrature encoder* sends square wave type signals. When the shaft rotates at a constant velocity, the A and B outputs are square waves and are at the same frequency. However they are out of phase with each other by 90° . When the encoder shaft rotates in one direction, each A pulse leads the corresponding B pulse by 90° . When it rotates the other direction each A pulse lags its B pulse by 90° .

The signals illustrated in Figure 37 indicate that the encoder shaft rotates in one direction at first. Its speed of rotation decreases to 0 and then it starts rotating the other direction. The signals are shown as differential. \bar{A} is the inverse of the signal A and \bar{B} is the inverse of signal B.

Figure 37: Signals Transmitted by a Quadrature Encoder with Differential Outputs

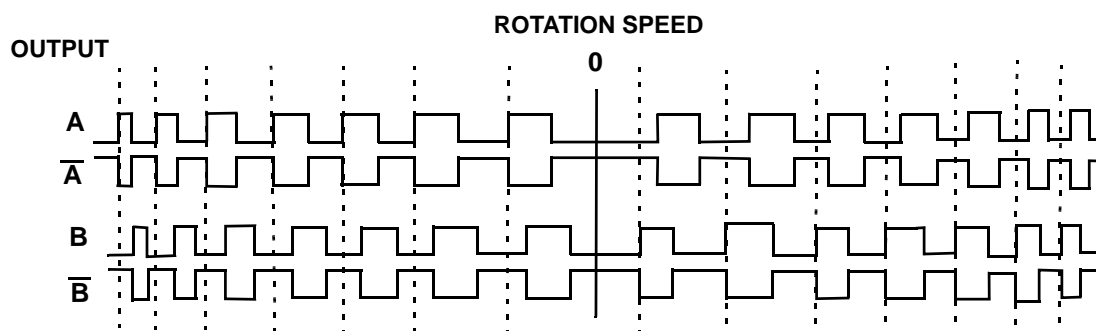

The maximum input frequency is 250,000 lines per second, which results in 1,000,000 Feedback Units (FUs) per second.

Figure 38: Counting Quadrature Pulses

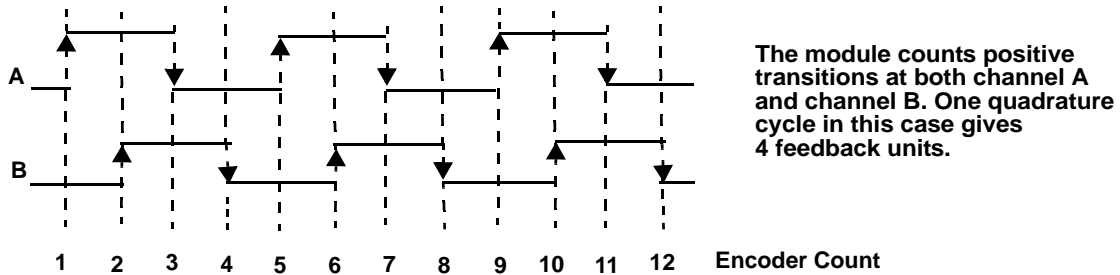

There is a 24-bit up/down counter for each channel. It is incremented or decremented on each A, B edge as shown in Figure 38. There is also a 24-bit latch associated with each encoder channel.

The module can be programmed so that the counter value is "latched" or stored under one of these conditions:

- an index pulse from the encoder
- a positive or negative transition of the fast input
- the next index pulse after the required transition of the fast input

Each of the five 24-bit latches has a *fast 24 VDC input* associated with it. Each input is optically isolated. This input is intended to receive a signal from a device other than an encoder. It is typically used for referencing or synchronization purposes.

Fast input characteristics include:

- the detection of a signal occurs faster than it does for the DC inputs in other modules, due to less filtering. Because of this there is also less noise immunity.
- the response to a fast input signal is independent of ladder scan time. The module can be programmed to latch a position count as soon as this input is detected.

12.10 ASIU Analog Input Operation (AUX Connector)

There is one differential analog input channel on this module. The input range is ± 10 VDC. The analog input voltage is sampled every 100 μ sec by a 12-bit A/D converter. The most recent conversion result is stored in an on-board register. This register can be read at any time by the ladder.

The analog input signal passes through a common mode and differential mode filter prior to being applied to the A/D converter. These filters improve the noise immunity of the module.

13 MMC for PC Option Modules

13.1 General

The MMC for PC will accept a MMC for PC Option Module for network communications, either DeviceNet, Profibus or Digital Line Shaft (DLS). The board is mounted 0.8" above the MMC for PC board. When the MMC for PC Option Module is mounted on the MMC for PC board, the combined unit will occupy two slots. The board is located so the network connector will be positioned in a slot aperture of the host PC.

NOTE
Throughout this document, "MMC for PC Option Module" is a generic term that refers to any communication module (DeviceNet, Profibus or Digital Line Shaft (DLS)) that can be installed on the MMC for PC board. It does not refer to a specific type of communication network or module.

13.2 Mounting the MMC for PC Option Module

1. Shut down and turn off your computer, monitor and all attached peripherals.
2. Unplug each component from the wall electrical outlet or surge protector/power strip.
3. Disconnect all power to the computer and MMC for PC control system.

WARNING	
	<p>Before you mount the MMC for PC Option Module onto the MMC for PC board in the computer, make sure that power is disconnected from the computer and to the devices the MMC for PC is wired to.</p> <p>Make sure the computer is adequately grounded before mounting the MMC for PC Option Module. Any attempt to operate or service the computer without adequate ground may result in serious personal injury and/or damage to the MMC for PC board and control system.</p>

4. Remove the computer cover as described in the documentation for your specific computer.
5. Locate the MMC for PC board.
6. At the back of the computer, remove the screw that secures the MMC for PC board chassis to the back of the computer frame.
7. Remove the MMC for PC board from the slot. Refer to Figure 39.
8. Carefully pull the board straight up until the board is completely removed from the slot.

Figure 39: Removing the MMC for PC Board

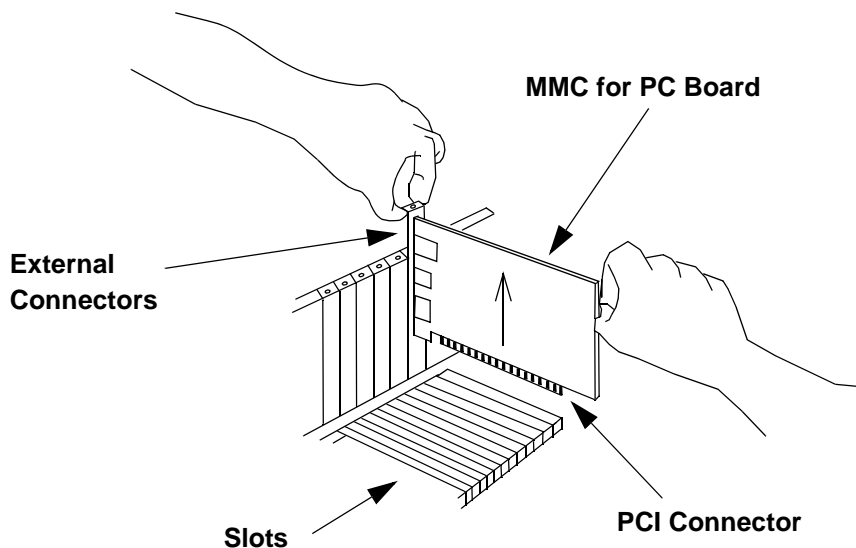

9. Remove the MMC for PC Option Module from its anti-static bag.

STATIC ELECTRICITY PRECAUTIONS

The MMC for PC board, the MMC for PC Option Module and the internal components of the PC are sensitive to static electricity. The following precautions reduce the possibility of damaging these components:

Wear a grounding wrist strap and attach the ground clip to the computer's metal frame.

Before handling the MMC for PC board or the MMC for PC Option Module or touching anything inside the PC, discharge your body's static electric charge by touching a grounded (earthed) surface. If the PC is connected to a grounded outlet, you can do this by touching the outside metal piece of the PC chassis.

Do not remove the MMC for PC Option Module from its antistatic bag until you are ready to install it.

When removing the module from the anti-static bag, hold it by the edges. Avoid touching components on the module.

Do not slide the module over any surface.

Avoid plastic, vinyl and styrofoam in your work area.

After you remove the MMC for PC Option Module from the MMC for PC board, immediately place it in an antistatic bag until it is used again.

Figure 40: Positioning MMC for PC Option Module on the MMC for PC Board

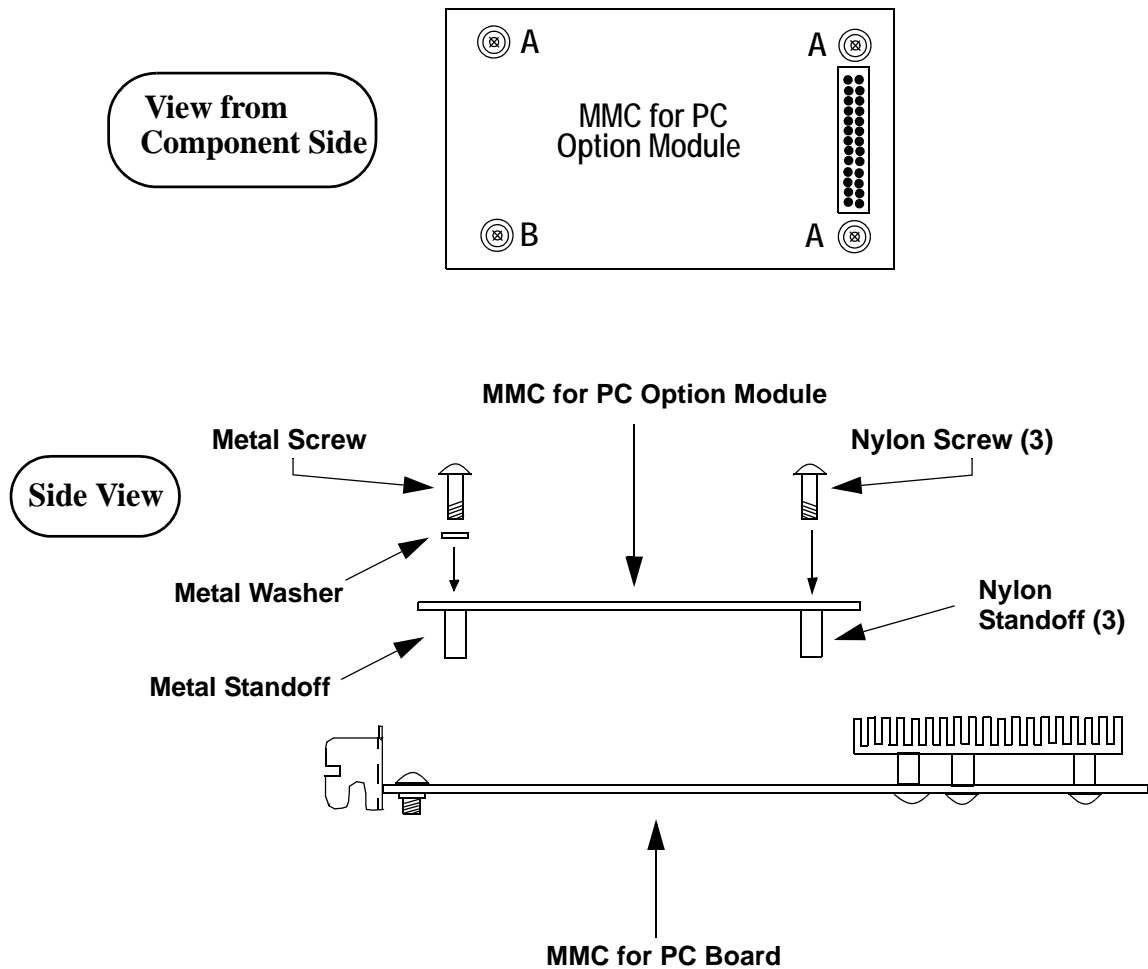

10. Refer to Figure 40. At the three locations marked “A”, place a *nylon* standoff on the solder side of the MMC for PC Option Module (on the DLS module if you are installing both a DLS module and a DeviceNet module) and secure the standoff to the module using a 4-40 x 1/4" nylon screw inserted from the component side of the module.
11. Refer to Figure 40. At the location marked “B”, place a *metal* standoff on the solder side of the MMC for PC Option Module and secure the standoff to the module using a #4 star washer and a 4-40 x 3/8" *metal* screw inserted from the component side of the module.
12. Refer to Figure 40. Position the MMC for PC Option Module on the component side of the MMC for PC Board. Make sure that the connector on the MMC for PC Option Module is properly aligned with the connector on the MMC for PC board.

Figure 41: Attaching MMC for PC Option Module to the MMC for PC Board

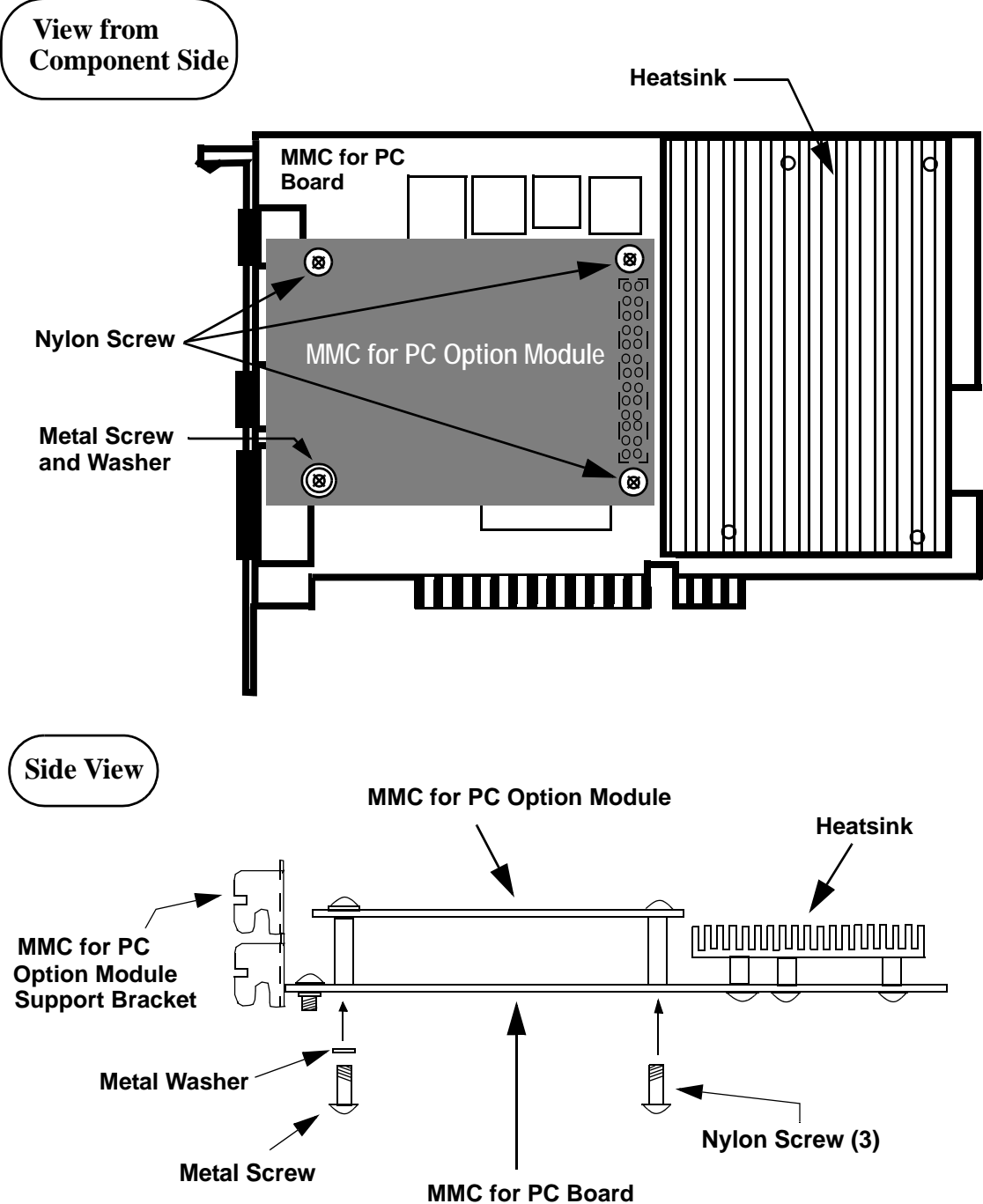

13. Refer to Figure 41. Carefully press down on the MMC for PC Option Module so the MMC for PC Option Module standoffs contact the MMC for PC Board and the Header Pin Connector on the MMC for PC Option Module connects to the Header Socket Connector on the MMC for PC board.
14. Refer to Figure 41. At the three locations with nylon standoffs, secure the MMC for PC Option Module to the MMC for PC board using 4-40 x 1/4" nylon screws inserted from the solder side of the MMC for PC board.
15. Refer to Figure 41. At the location with the metal standoff, secure the MMC for PC Option Module to the MMC for PC board using a #4 star washer and a 4-40 x 3/8" metal screw inserted from the solder side of the MMC for PC board.
16. Carefully tighten all four screws until the MMC for PC Option Module is firmly attached to the MMC for PC board.

IMPORTANT

It is very important that the MMC for PC Option Module is firmly attached to the MMC for PC board. Failure to do so may cause poor connections to external devices or damage to the board. However, do not overtighten the screws. Overtightening the screws may cause damage to the MMC for PC Option Module or the MMC for PC board.

17. The Profibus Module has a support bracket attached at the factory, the DeviceNet Module and the DLS Module do not. If you are installing a DeviceNet Module or a DLS Module, you must install the supplied support bracket using the screw provided. Make sure the screw is firmly tightened.
Note: If a DeviceNet module is being mounted on top of the DLS module, see "Mounting a DeviceNet Module to a DLS Module" on page 102.
18. Insert the MMC for PC board back into the computer and secure the bracket with the mounting screw. If you are installing a Profibus Module, also secure the Module Support Bracket with a screw. Make sure all screws are firmly tightened.
19. Reattach and secure the screws for the computer cover.
20. Plug in all power cords and turn on the monitor. Turn on the computer. If you do not get the proper start-up display, check all connections and make the necessary changes.

13.3 Mounting a DeviceNet Module to a DLS Module

Figure 42: DLS Module Attached to MMC for PC Option Module

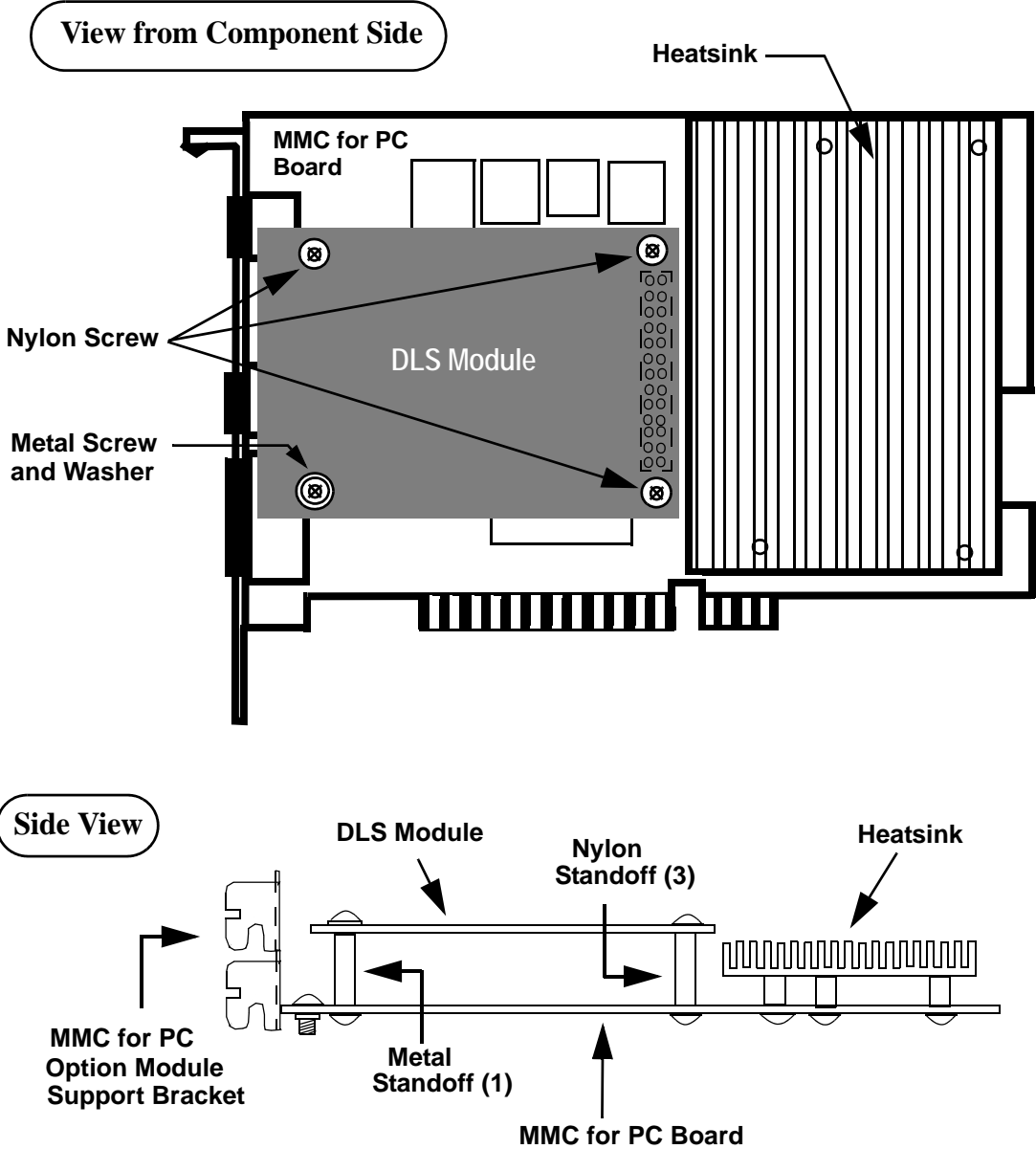
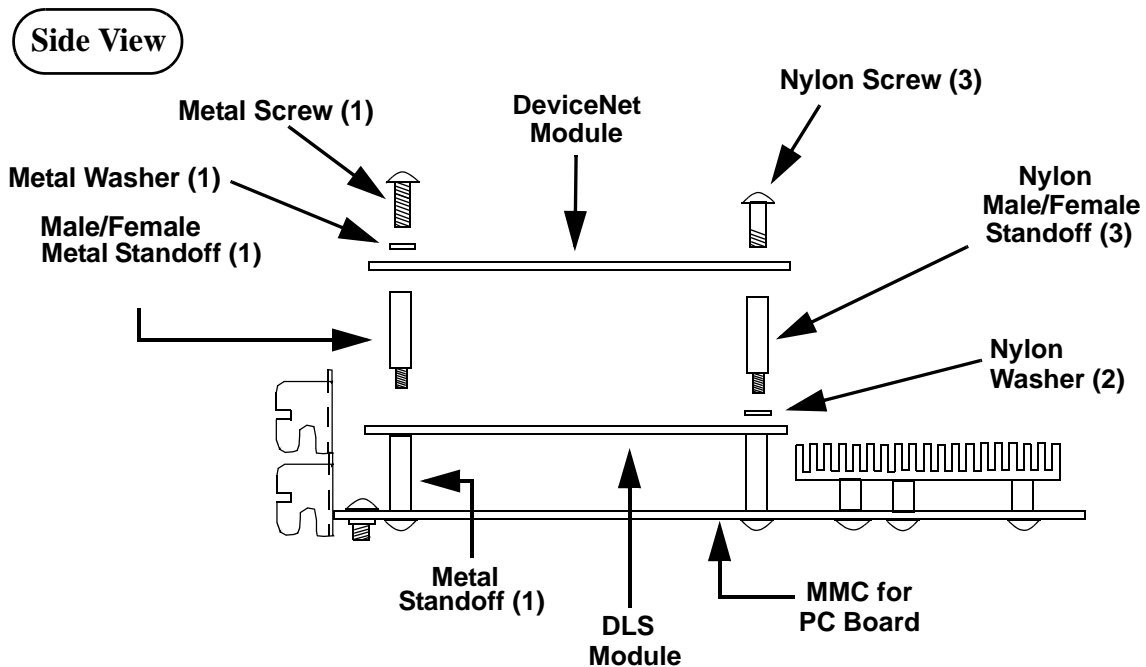

Figure 43: Attaching DeviceNet Module to DLS Module



1. Remove the metal screw, the metal washer and the three nylon screws that were used to attach the DLS module to the standoffs on the MMC for PC board.
2. Locate the four mounting holes on the DLS Module.
3. Locate the mounting hole over the metal standoff used to mount the DLS module to the MMC for PC board.
4. At the mounting hole that matches up with the metal standoff mentioned in step 3, carefully turn a metal male/female standoff clockwise into the hole on the DLS module as shown in Figure 43. Turn the metal standoff until it is firmly attached to the DLS module. **DO NOT OVERTIGHTEN.**
5. At the holes on either side of the 26 pin connector, place one nylon washer over each mounting hole. Carefully turn a nylon male/female standoff clockwise into the remaining three holes on the DLS module as shown in Figure 43. Turn the nylon standoffs until they are firmly attached to the DLS module. **DO NOT OVERTIGHTEN.**
6. Position the DeviceNet module over the DLS module as shown in Figure 43. Make sure that the connector on the DeviceNet module is properly aligned with the connector on the DLS module.
7. Carefully press down on the DeviceNet module so the DLS standoffs contact the DeviceNet module and the Header Pin Connector on the DeviceNet module connects to the Header Socket Connector on the DLS module.

8. At the three locations with nylon standoffs, secure the DeviceNet module to the DLS module using the 4-40 x 1/4" nylon screws.
9. At the location with the metal standoff, secure the MMC for PC Option Module to the MMC for PC board using a #4 star washer and the 4-40 x 3/8" metal screw.
10. Carefully tighten all four screws until the DeviceNet option module is firmly attached to the DLS module.
11. Continue with installation at Step 18 on page 101.

IMPORTANT

It is very important that the DeviceNet module is firmly attached to the DLS module. Failure to do so may cause poor connections to external devices or damage to the board. However, do not overtighten the screws. Overtightening the screws may cause damage to the DeviceNet module or DLS module.

13.4 Network Interface Connections

13.4.1 DeviceNet Module

13.4.1.1 DeviceNet Connections

Figure 44: DeviceNet Connections

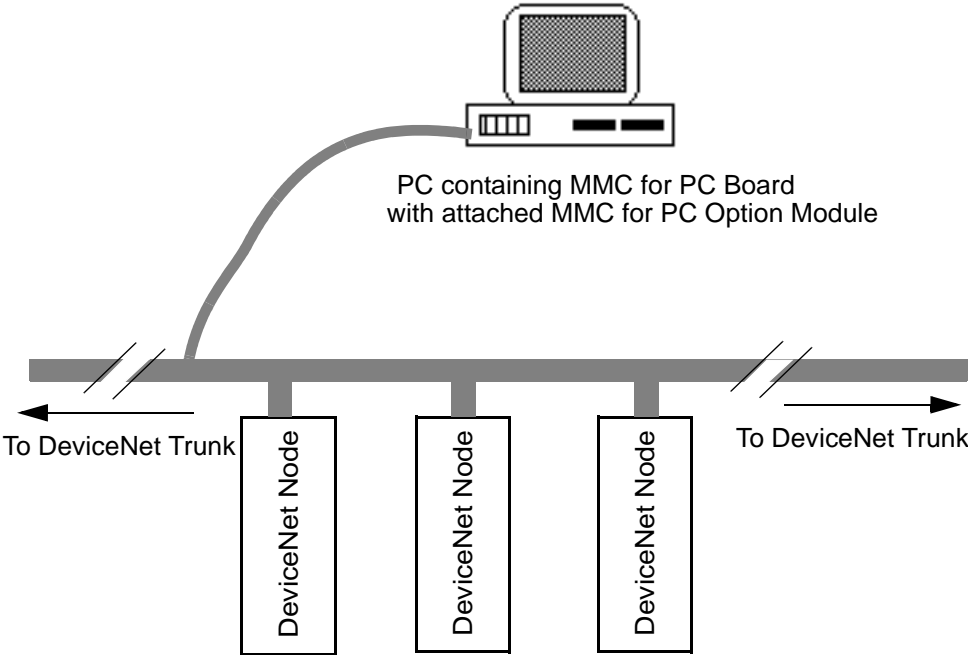

13.4.1.2 DeviceNet Port

Figure 45: DeviceNet Port

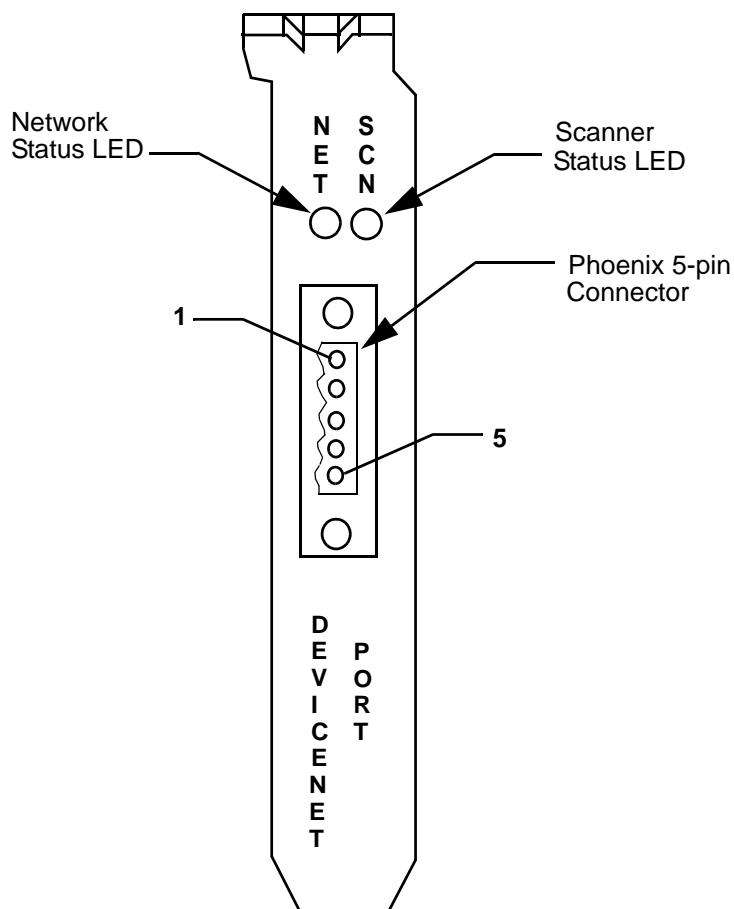

Table 15: Pinout for DeviceNet Port

Pin #	Signal Name	Standard Wire Colors	In/Out
1	V-	black	
2	CAN_L	blue	
3	Shield (drain)	bare	
4	CAN_H	white	
5	V+	red	

13.4.1.3 DeviceNet Module LEDs

The two configuration port LEDs and the two DeviceNet port LEDs are described below.

Table 16: DeviceNet Module LEDs

LED	Color	State	Definition
Network status	Green	OFF	Off-line
		ON	On-line and connected to all nodes
		Flashing	On-line but connection to all nodes not established
	Red	ON	Unrecoverable Fault (duplicate MAC ID check failed, critical bus fault, etc.)
		Flashing	I/O connections in timed-out state or other Recoverable Fault
Scanner status	Green	OFF	No power or else reset asserted
		ON	Scanner OK and active
		Flashing	Scanner OK but not active
	Red	ON	Hardware or software error
		Flashing	Recoverable configuration error (invalid data downloaded)
	Orange	ON	Configuration (download) mode

13.4.2 Profibus Module

13.4.2.1 Profibus Connections

Figure 46: Profibus Connections

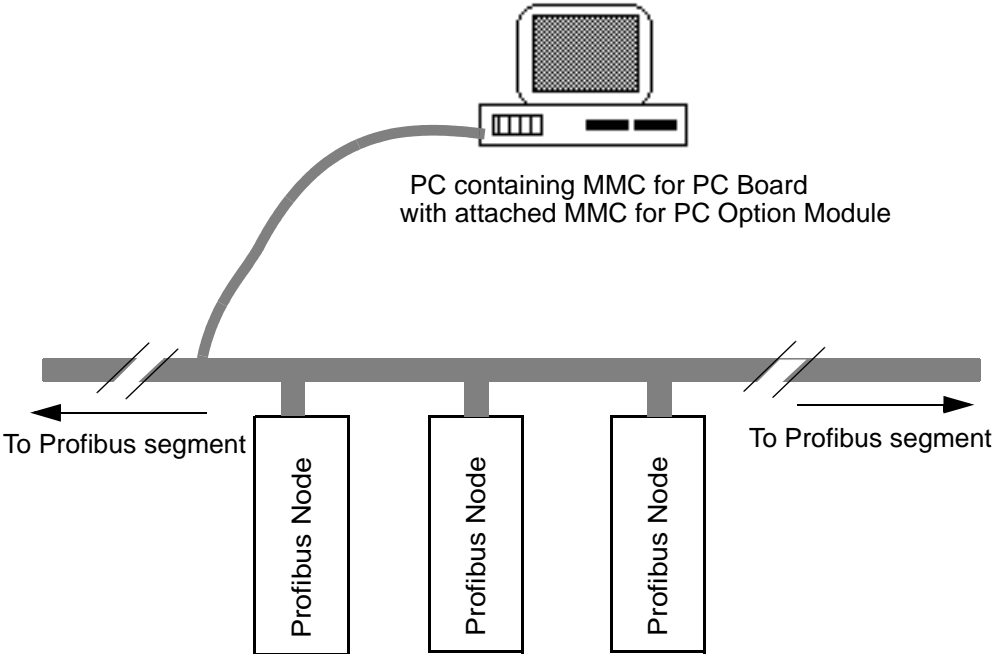

13.4.2.2 Profibus Port

Figure 47: Profibus Port

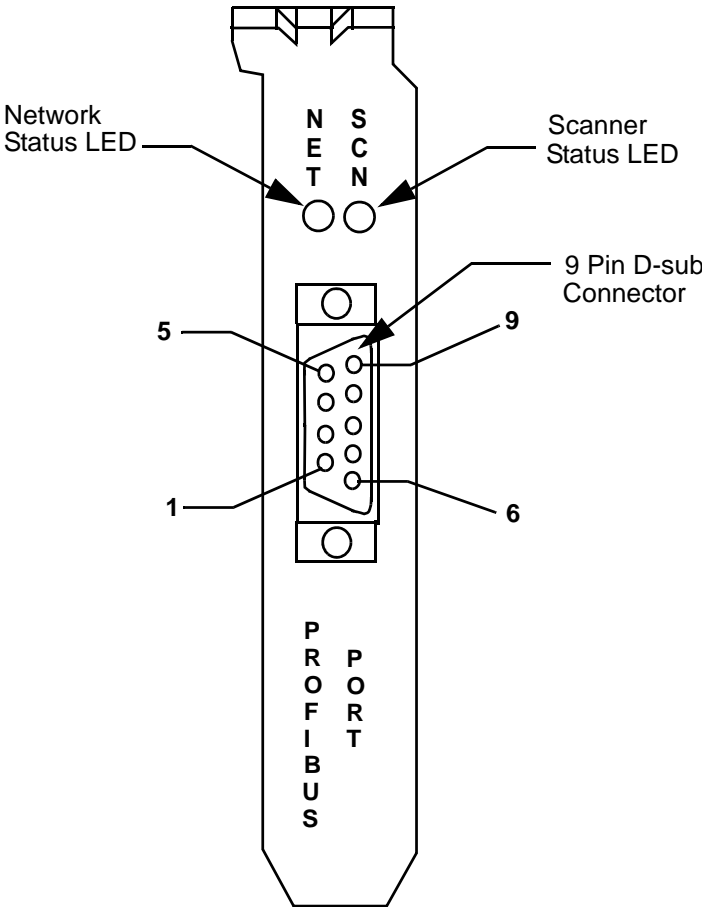

Table 17: Pinout for Profibus Port

Pin #	Signal Name
1	Chassis ground
2	Reserved
3	data +
4	Tx enable
5	Isolated ground
6	voltage +
7	reserved
8	data -
9	reserved

13.4.2.3 Profibus Module LEDs

The two configuration port LEDs and the two Profibus port LEDs are described below.

Table 18: Profibus Module LEDs

LED	Color	State	Definition
Network status	Green	OFF	Off-line
		ON	On-line, no physical layer or data layer errors (or Profibus cable not connected)
	Red	ON	On-line, bus error (baud rate or wiring problem)
Scanner Status	Green	OFF	No power or else reset asserted, interface closed
		ON	Scanner communicating, data exchanging, no slave device errors
		Flashing	Scanner in start-up
	Red	ON	At least one slave faulted
	Orange	ON	Configuration (download) mode

13.4.3 Digital Line Shaft (DLS) Module

13.4.3.1 DLS Connections

Figure 48: DLS Connections

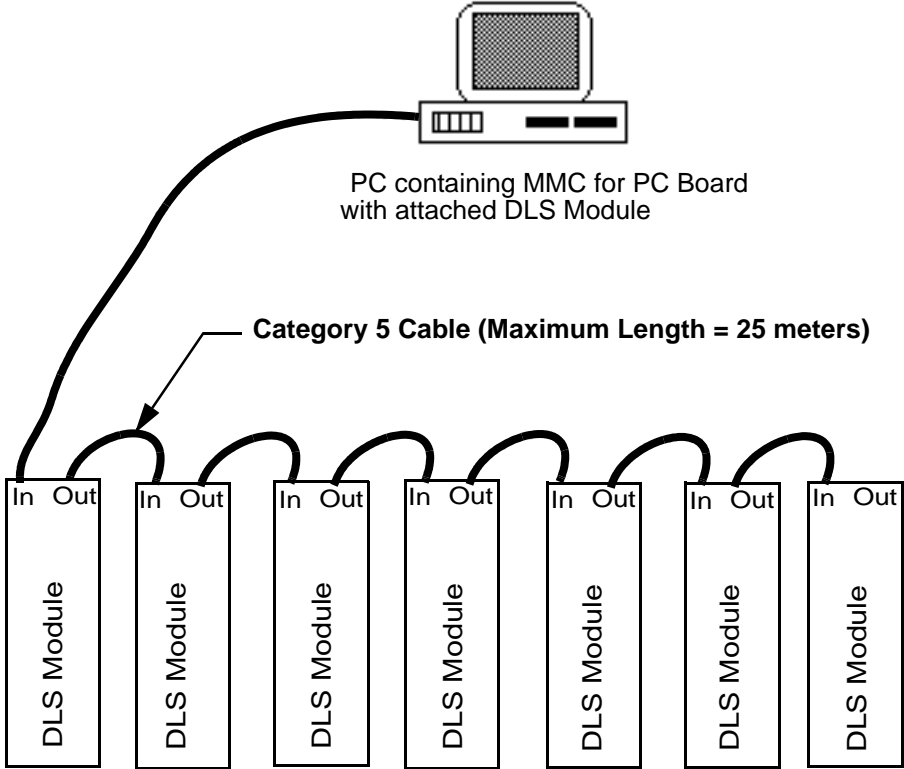

Up to 8 MMC for PCs with Digital Line Shaft Modules can be connected as shown above. Each module resides on an MMC for PC SERCOS board.

Note: The DLS Module will only work with a DLS compatible MMC for PC/SERCOS Module (Part Nos. M.1301.4104, M.1301.4103, M.1301.4102).

13.4.3.2 DLS Module Port

Figure 49: DLS Module Port

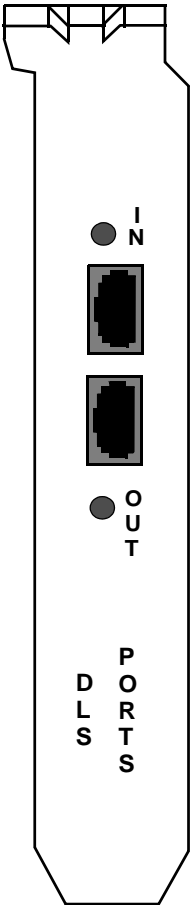

The DLS ports use RJ-45 style 8-pin connectors using 100 ohm unshielded twisted pair category 3 or 5 cable (IEEE 802.3 Section 14.4). The maximum length at the twisted pair cable segment is 25 m (82.5 ft.).

Note: The connector is also suitable for shielded cable and will ground the shield to chassis.

13.4.3.3 DLS Module LEDs

The two configuration port LEDs and the two Profibus port LEDs are described below.

Table 19: DLS Module LEDs

In Link OK(IN OK) Green	
ON	Indicates that there is a DLS Module properly connected and communicating with this DLS Module's IN port.
OFF	Indicates that there is not a DLS Module properly connected and communicating with this DLS Module's IN port.
Out Link OK(OUT OK) Green	
ON	Indicates that there is a DLS Module properly connected and communicating with this DLS Module's OUT port.
OFF	Indicates that there is not a DLS Module properly connected and communicating with this DLS Module's OUT port.

14 Specifications

14.1 MMC for PC Analog Board Specifications

Servo Update Rates						
	Update Rates					
	8 ms	4 ms	2 ms	1 ms	.5 ms	.25 ms
Maximum number of axes*	32	32	32	24/12	12/6	6/3
Maximum number of ASIUs	8	8	8	6	3	2

*Where two numbers are listed they represent High/Low. The High number is typical when running RATIO_GR, RATIOCAM, VEL_STRT, POSITION, DISTANCE move types etc... The Low number is typical when running time axes, servo tasks, RATIO_RL, M_LINCIR, M_SCRVLC move types etc.. The Low number types place a heavier burden on CPU time than the High number types.

General	
Part Number	Use MMC for PC Analog Package M.1300.5974
System Requirements	One PCI Local Bus slot, Standard 2.1 compatible, 133MHz Pentium or faster
Processor Speed	128MHz
Board Dimensions	6.6" L x 4.2" H
Flash Memory	1 MB
RAM Memory	1MB (Refer to the PiCPro Online Help for partitioning, RAM into Application, RAM Disk and Variable Memory storage areas)
Connector Port from MMC for PC board at PC	RJ45 port, secured protocol
Input voltage range	+20 VDC to 30 VDC (absolute maximum), 24V nominal
Input power	6.5 W @ 24V (.27 amps), PCI bus derived or external

Environmental	
Operating temperature range	0°C to 55°C (32° F to 131°F)
Storage temperature range	-40°C to 85°C (-40°F to 185°F)
Humidity	5 to 95%, non-condensing
Conformity	
CE Marked	<p>Conforms to Directives 73/23/EEC, 89/336/EEC, 92/31/EEC, 93/68/EEC by conforming to the following standards:</p> <p>EN 50081-2:1993EMC Generic Industrial Emissions EN 50082-2:1995EMC Generic Industrial Immunity EN 61131-2:1994/A11:1996 Low voltage directive requirements for programmable controllers</p> <p>Operates with emissions below EN55011/ CISPR 11 Class A limits</p> <p>Immune to:</p> <ul style="list-style-type: none"> •Electrostatic discharge (4K V contact mode, 8K V air discharge) per EN61000-4-2 •RF electromagnetic fields per EN61000-4-3, ENV 50141, and ENV50204 •Electrical fast transients per EN61000-4-4 •Magnetic fields per EN61000-4-8 <p>Refer to the EMC Guidelines for more information.</p>
UL and C/UL Listed	E126417

14.2 MMC for PC SERCOS Board Specifications

Servo Update Rates				
	Update Rates			
	8 ms	4 ms	2 ms	1 ms
Maximum number of axes	32	32	16	8

General	
Part Number	For up to 32 axes, M.1301.4104 For up to 16 axes, M.1301.4103 For up to 8 axes, M.1301.4102
System Requirements	One PCI Local Bus slot, Standard 2.1 and 2.2 compatible 133MHz Pentium or faster
Processor Speed	128Mhz
Board Dimensions	6.6" L x 4.2" H
Flash Memory	1 MB
RAM Memory	1MB (Refer to the PiCPro Online Help for partitioning RAM into Application, RAM Disk and Variable Memory storage areas)
Connector Port from MMC for PC board at PC	RJ45 port, secured protocol
Input voltage range	+20 VDC to 30V DC (absolute maximum), 24V nominal
Input power	6.5 W @ 24V (.27 amps), PCI bus derived or external

Environmental	
Operating temperature range	0°C to 55°C (32° F to 131°F)
Storage temperature range	-40°C to 85°C (-40°F to 185°F)
Humidity	5 to 95%, non-condensing
Conformity	
CE Marked	<p>Conforms to Directives 73/23/EEC, 89/336/EEC, 92/31/EEC, 93/68/EEC by conforming to the following standards:</p> <p>EN 50081-2:1993EMC Generic Industrial Emissions EN 50082-2:1995EMC Generic Industrial Immunity EN 61131-2:1994/A11:1996 Low voltage directive requirements for programmable controllers</p> <p>Operates with emissions below EN55011/ CISPR 11 Class A limits</p> <p>Immune to:</p> <ul style="list-style-type: none"> •Electrostatic discharge (4K V contact mode, 8K V air discharge) per EN61000-4-2 •RF electromagnetic fields per EN61000-4-3, ENV 50141, and ENV50204 •Electrical fast transients per EN61000-4-4 •Magnetic fields per EN61000-4-8 <p>Refer to the EMC Guidelines for more information.</p>
UL and C/UL Listed	E126417

14.3 ASIU Specifications

General	
Part Number for ASIU-2	M.1300.5970
Part Number for ASIU-4	M.1300.4422
IN and OUT RJ45 ports	RJ45 port, secured protocol
Input voltage range	+20 VDC to 30 VDC (absolute maximum), 24V nominal
Input power	350 mA plus I/O power
Operating temperature range	5°C to 55°C (41°F to 131°F)
Storage temperature range	-40°C to 85°C (-40°F to 185°F)
Humidity	5 to 95%, non-condensing
Maximum length of cable between MMC for PC Analog board and first ASIU	82.5 ft.(25 m)
Maximum length of cable between two ASIUs	82.5 ft.(25 m)
Type of cable between MMC for PC Analog board and first ASIU	CAT5 straight pinned. Use shielded cable in noisy environments.
Type of cable between two ASIUs	CAT5 straight pinned. Use shielded cable in noisy environments.

Conformity	
CE Marked (Pending)	<p>Conforms to Directives 73/23/EEC, 89/336/EEC, 92/31/EEC, 93/68/EEC by conforming to the following standards:</p> <p>EN 50081-2:1993EMC Generic Industrial Emissions EN 50082-2:1995EMC Generic Industrial Immunity EN 61131-2:1994/A11:1996 Low voltage directive requirements for programmable controllers Operates with emissions below EN55011/ CISPR 11 Class A limits</p> <p>Immune to:</p> <ul style="list-style-type: none"> •Electrostatic discharge (4K V contact mode, 8K V air discharge) per EN61000-4-2 •RF electromagnetic fields per EN61000-4-3, ENV 50141, and ENV50204 •Electrical fast transients per EN61000-4-4 •Magnetic fields per EN61000-4-8 <p>Refer to the EMC Guidelines for more information.</p>
UL and C/UL Listed (Pending)	E126417
Physical size	<p>2.25" wide x 9.6" high x 5.3" deep 57.15 mm x 243.84 mm x 134.62 mm</p>

Analog Output	
Output channels	2 or 4
Resolution	16 bits
Output voltage range	± 10 VDC
Maximum output current (1K Ω load)	± 10 mA
Power on output voltage	0 V ± 100 mV
Scan loss output voltage	0V ± 100 mV
Accuracy	$\pm 0.375\%$ of FSR Drift ± 50 ppm/ $^{\circ}$ C
Update rate	68 μ sec
Analog Input	
Input channel	1
Resolution	12 bits
Input voltage range	± 10 V
Accuracy	$\pm 0.2\%$ of FSR
Sample rate	100 μ sec
Common mode filter	3 dB @ 10 K Hz
Differential mode filter	3 dB @ 475 Hz

Encoder Input	
Input channels	3 or 5
Input receiver type	2632 differential RS422 type receiver
Encoder signals	Differential quadrature
Input threshold	± 750 mV
Maximum input voltage	5 V
Maximum A or B input frequency	250 K Hz (1 M feedback unit count rate)
Fast input voltage	Nominal 24 VDC, maximum 30 VDC
Guaranteed on voltage	15 VDC
Guaranteed off voltage	5 VDC
Turn on/off time	1 ms
General, Auxiliary and Axis DC Inputs	
Configuration	The general inputs are divided into two groups of eight. Each group can be configured for sourcing or sinking. The auxiliary inputs are divided into two groups of six inputs. Each group can be configured for sourcing or sinking. The axis inputs have one input per axis. Each input can be configured for sourcing or sinking. Operates with IEC Type 1 inputs (per IEC 1131=2).
Input voltage	Nominal 24 VDC, maximum 30 VDC
Guaranteed on voltage	15 VDC
Guaranteed off voltage	5 VDC
Turn on/off time	1 ms

General DC Outputs	
Number of outputs	16 outputs
Input voltage	Nominal 24 VDC, 30 VDC maximum
Configuration	Two groups of eight solid-state switches.
Protection of logic circuits	Optical isolation between the logic and field side, transient suppression on the 24V external supply
Maximum current	.25 A per output
Voltage range	+20 VDC to 30V DC (absolute maximum), 24V nominal
Switch characteristics	Solid-state switches
Time delay on for resistive loads	50 μ sec max
Time delay off for resistive loads	50 μ sec max
Leakage current in off state	0.5 mA max
Switch voltage, maximum ON	1 VDC max
Short circuit protection for each group	15 A (max) pulses for about 130 μ sec every 100 msec until short is removed
Scan loss response	Outputs turn off
Axis DC Outputs	
Number of outputs	2 outputs per axis
Configuration	Each set of axis outputs can be configured as sourcing or sinking.
Maximum current	100 mA per output
Voltage range	24 VDC nominal, 5 to 30 VDC range
Scan loss response	Outputs turn off
Auxiliary DC Output	
+5 VDC	150 mA maximum current available. Connections to this point should be over short distances and away from electric noise signals.

14.4 MMC for PC Option Modules Specifications

14.4.1 DeviceNet Module Specifications

General	
Part Number	M.1300.5981
Function	Interfaces to a DeviceNet network with up to 63 other nodes.
DeviceNet Port	Phoenix style 5-pin male connector
Supply Voltage Range	4.75 V to 5.25 V
Supply Current (steady state)	500 mA maximum (250 mA typical)
Peak Supply Current	750 mA
Vibration (per IEC 68-2-6)	10-57 Hz (constant amplitude .15 mm) 57 - 2000 Hz (acceleration 2 g)
Shock (per IEC 68-2-27)	Four shocks per axis (15g/11 msec)
Environmental	
Operating Ambient Temperature	0°C to 60°C (32° F to 140°F)
Non-operating Ambient Temperature	-25°C to 70°C (-13° F to 158°F)
Operating Humidity	5 to 95% non-condensing

Conformity	
CE Marked	<p>Conforms to Directives 73/23/EEC, 89/336/EEC, 92/31/EEC, 93/68/EEC by conforming to the following standards:</p> <p>EN 50081-2:1993 EMC Generic Industrial Emissions EN 50082-2:1995 EMC Generic Industrial Immunity EN 61131-2:1994/A11:1996 Low voltage directive requirements for programmable controllers</p> <p>Operates with emissions below EN55011/ CISPR 11 Class A limits</p> <p>Immune to:</p> <ul style="list-style-type: none"> • Electrostatic discharge (4K V contact mode, 8K V air discharge) per EN61000-4-2 • RF electromagnetic fields per EN61000-4-3, ENV 50141, and ENV50204 • Electrical fast transients per EN61000-4-4 • Magnetic fields per EN61000-4-8 <p>Refer to the EMC Guidelines for more information.</p>
UL and C/UL Listed	File No. E126417 NRAQ Programmable Controllers

14.4.2 Profibus Module Specifications

General	
Part Number	M.1300.5984
Function	Interfaces to a Profibus network with up to 31 other nodes, without a repeater.
Profibus Port	9-pin D-sub female connector
Supply Voltage Range	4.75 V to 5.25 V
Supply Current (steady state)	500 mA maximum (250mA typical)
Peak Supply Current	750 mA
Vibration (per IEC 68-2-6)	10-57 Hz (constant amplitude .15 mm) 57 - 2000 Hz (acceleration 2 g)
Shock (per IEC 68-2-27)	Four shocks per axis (15g/11 msec)
Environmental	
Operating Ambient Temperature	0°C to 60°C (32° F to 140°F)
Non-operating Ambient Temperature	-25°C to 70°C (-13° F to 158°F)
Operating Humidity	5 to 95% non-condensing

Conformity	
CE Marked	<p>Conforms to Directives 73/23/EEC, 89/336/EEC, 92/31/EEC, 93/68/EEC by conforming to the following standards:</p> <p>EN 50081-2:1993 EMC Generic Industrial Emissions EN 50082-2:1995 EMC Generic Industrial Immunity EN 61131-2:1994/A11:1996 Low voltage directive requirements for programmable controllers</p> <p>Operates with emissions below EN55011/ CISPR 11 Class A limits</p> <p>Immune to:</p> <ul style="list-style-type: none"> • Electrostatic discharge (4K V contact mode, 8K V air discharge) per EN61000-4-2 • RF electromagnetic fields per EN61000-4-3, ENV 50141, and ENV50204 • Electrical fast transients per EN61000-4-4 • Magnetic fields per EN61000-4-8 <p>Refer to the EMC Guidelines for more information.</p>
UL and C/UL Listed	File No. E126417 NRAQ Programmable Controllers

14.4.3 Digital Line Shaft (DLS) Module Specifications

General	
Part Number	M.1301.8981
Function	Interfaces up to 8 Digital Line Shaft Modules as part of a cluster of up to 8 MMC for PC systems.
DLS Ports	Two RJ45 Shielded Connectors, one for Input, one for Output.
Supply Voltage Range	4.75 V to 5.25 V
Supply Current (steady state)	500 mA maximum (250mA typical)
Peak Supply Current	750 mA
Vibration (per IEC 68-2-6)	10-57 Hz (constant amplitude .15 mm) 57 - 2000 Hz (acceleration 2 g)
Shock (per IEC 68-2-27)	Four shocks per axis (15g/11 msec)
Environmental	
Operating Ambient Temperature	0° C to 55° C (32° F to 131° F)
Non-operating Ambient Temperature	-25° C to 70° C (-13° F to 158° F)
Operating Humidity	5 to 95% non-condensing

Conformity	
<p>CE Marked (Pending)</p>	<p>Conforms to Directives 73/23/EEC, 89/336/EEC, 92/31/EEC, 93/68/EEC by conforming to the following standards:</p> <p>EN 50081-2:1993 EMC Generic Industrial Emissions EN 50082-2:1995 EMC Generic Industrial Immunity EN 61131-2:1994/A11:1996 Low voltage directive requirements for programmable controllers</p> <p>Operates with emissions below EN55011/ CISPR 11 Class A limits</p> <p>Immune to:</p> <ul style="list-style-type: none"> • Electrostatic discharge (4K V contact mode, 8K V air discharge) per EN61000-4-2 • RF electromagnetic fields per EN61000-4-3, ENV 50141, and ENV50204 • Electrical fast transients per EN61000-4-4 • Magnetic fields per EN61000-4-8 <p>Refer to the EMC Guidelines for more information.</p>
<p>UL and C/UL Listed</p>	<p>File No. E126417 NRAQ Programmable Controllers</p>

INDEX

Numerics

- 24-bit latch 94
- 24-bit up/down counter 94

A

- analog input
 - theory of operation 95
- analog output
 - theory of operation 93
- analog output to drive connections 64
- analog servo board 10
- analog servo I/O axis configuration 15
- analog servo module 15
- ASIU
 - connecting to an application 49
- ASIU control cabinet
 - specifications 33
- auxiliary I/O
 - connector 66
 - general purpose inputs 69
 - pinout 66
- available I/O 15
- axis connectors
 - pinout 61
- axis DC input to drive ready connection 64
- Axis I/O 15

C

- cables 57
- components 13
- configuration
 - sink 62
 - source 62
- connections
 - analog output to drive 64
 - ASIU network 50
 - axis DC input to drive 64
 - encoder inputs to drive encoder output 65
 - fast inputs 68
 - general purpose inputs 59
- connector
 - auxiliary I/O 66
 - axis 61
 - motion control 56

- power 60
 - to ASIU 56
- current
 - leakage 92

D

- DC input
 - theory of operation 90
- DC output theory 90
- DeviceNet
 - LEDs 107
- DeviceNet configuration port 107
- DeviceNet module
 - mounting to a DLS module 102
- diagnostic
 - LED 85
 - power-on 79
 - run-time 80
- differential devices 46
- dimensions
 - mounting 31
- distribution
 - power 37
- DLS configuration port 113
- download hex 49, 51, 81

E

- electrical service & maintenance safety 5
- encoder
 - error detection 46
 - quadrature 15, 93
 - theory of operation 93
- encoder inputs to drive encoder output connections 65
- environment requirements
 - system 33

F

- fast input 94
 - characteristics 94
 - connection 68
 - sink configuration 68
 - source configuration 68
- fielbus module
 - positioning on MMC for PC board 99
- fieldbus module 96

mounting procedures 96

G

general inputs

sinking/sourcing 59

general purpose inputs

connections 59

ground

single point 40

grounding

protective earth 2

system 40

H

heat control 41

hex

download 49, 51, 81

I

I/O 15

I/O for ASIU 15

I/O, General

Output operation 88

IEC 90

IEC Standards 91

inductive load

internal diode 89

protection from 89

inspection

safety 4

internal diode

and inductive loads 89

K

kickback 89

L

ladder logic 7

latch

24-bit 94

counter value 94

LED

+5 VDC 85

collision 86

Diagnostic 79

diagnostic 85

diagnostics and troubleshooting 79

Link OK 87, 113

power 79

Receive 86

scan 79, 85

transmit 86

LEDs

ASIU 85

DeviceNet 107

Profibus 110

M

manual cleaning procedure 6

MMC for PC

analog servo board 10

connecting to an application 49

overview 7

power 55

SERCOS board 9

MMC for PC board

removing 97

MMC for PC Option Module

attaching to MMC for PC Board 100

mounting 96

positioning module on MMC for PC
board 99

models 13

module

analog servo 15

mounting

dimensions 31

N

network

connections for ASIU 50

O

operating limits 41

operation

ASIU 84

safety 4

setup procedures 47

overview

MMC for PC 7

P

peak reverse voltage 89

pinout

- auxiliary I/O 66
- axis connector 61
- port
 - DeviceNet configuration 107
 - DLS configuration 113
 - Profibus configuration 110
 - SERCOS 55
 - SERCOS receive 55
 - SERCOS transmit 55
- ports illustrated 13
- Power
 - general and environment requirements 33
- power
 - ASIU external power distribution 35
 - connection 60
 - distribution
 - basic 34
 - distribution in ASIU system 37
 - LED 79
 - optional external power and keyswitch connection 53
- power connector for ASIU 14
- power requirements
 - system 33
- power supply
 - sizing worksheet 38, 39
- power-on diagnostics 79
- procedure
 - manual cleaning 6
- Profibus
 - LEDs 110
- Profibus configuration port 110
- protection for inductive loads 89
- protective earth
 - grounding 2

Q

- quadrature
 - encoder 15, 93

R

- resistive load 89
- rotary switch for address definition 14
- run-time diagnostics 80

S

- safety
 - cleaning 6
 - electrical service & maintenance 5
 - inspection 4
 - operation 4
 - signs 2
 - system 1
- Scan 79
- scan
 - LED 85
- scan LED 79
- SERCOS board 9
- SERCOS port 55
- shielded twisted pair wiring 68
- shields 45
- signs
 - safety 2
- single point ground (SPG)
 - diagram 35
- sink configuration 62
- sizing
 - power supply 38, 39
- source configuration 62
- specifications 114
 - ASIU 118
 - ASIU control cabinet 33
 - DeviceNet Module 123
 - Digital Line Shaft (DLS) Module 127
 - Fieldbus Modules 123
 - MMC for PC Analog Board 114
 - Profibus Module 125
 - SERCOS Board 116
- static electricity precautions 98
- switch
 - main disconnect 35, 36, 47
 - wiring modules 48
- system
 - environment requirements 33
 - grounding 40
 - power requirements 33
 - power supply 34

T

- theory of operation
 - analog input 95

DC input 90
encoder 93
troubleshooting 51, 81

V

voltage
peak reverse 89

W

warning label
danger, warning, caution 3
hazard 3
LED radiation 3
wiring
shield twisted pair 68