

**INSTALLATION AND OPERATING
INSTRUCTIONS
FOR THE
NEXTDRIVE[™] INTELLIGENT
ADJUSTABLE FREQUENCY DRIVE
SC4000 SERIES**

**... THE INTELLIGENT CHOICE FOR YOUR
NEXTDRIVE APPLICATION**

WARNER ELECTRIC[®]



Congratulations!

Thank you for purchasing our **NEXTRIVE™ Intelligent Adjustable Frequency Drive** – another Warner Electric Product!

Expect exceptional performance. This unit is built to the highest quality standards for your complete satisfaction.

To assure many years of uninterrupted service, please read this owners manual to familiarize yourself with the operation and proper maintenance of the **NEXTRIVE™** unit

ENGINEERING CHANGES

Warner Electric reserves the right to make engineering refinements on all its products. Such refinements may affect information given in instructions, Therefore, **USE ONLY THE INSTRUCTIONS THAT ARE PACKED WITH THE PRODUCT.**

RECORD OF REVISION		
Revision	Date	Description
A	10/17/97	Initial Release
B	11/11/97	Improve Quick Start section and minor corrections to parameters and specifications

Table of Contents

<u>Section</u>	<u>Description</u>	<u>Page</u>
1.0	Cautions and Warnings	4
2.0	Introduction	6
3.0	Installation	7
3.1	Pre-Installation	7
3.2	Handling of the Drive After Delivery	7
3.3	Where to Locate the Drive	7
3.4	Application Considerations	8
3.5	Quick Start Guide	8
3.6	Motor Selection	10
3.7	Input Line Considerations	10
3.8	Input Line Routing	14
3.9	Output Power Considerations	15
3.10	Analog and Digital Signal Considerations	16
3.11	Connection Diagrams	18
3.11.1	Power Terminal Connections	18
3.11.2	Analog Input Connections	19
3.11.3	Digital Input Connections	21
3.11.4	Digital Output / Relay Connections	23
3.12	Outline Drawings	24
4.0	Specifications	27
5.0	Operation	34
5.1	Keypad Description	34
5.2	Operation of the Drive From the Keypad	36
5.3	Menu Maneuvering	37
5.4	Menu and Parameter Descriptions	38
5.4.1	SetUp Menu:	38
5.4.2	Main Menu:	38
5.4.3	Status Menu:	40
5.4.4	OpMode Menu:	41
5.4.5	Preset Menu:	44
5.4.6	I/O Menu:	46
5.4.7	Serial Parm:	49
5.4.8	Fault Status:	49
5.4.9	Parameter Table	51
6.0	Serial Communications	57
7.0	Troubleshooting	62
A	SC4000 General Specifications	A-1

1.0 - Cautions and Warnings

Before installing and operating your NEXTDRIVE™ Adjustable Frequency Drive, it is extremely important both to you and us here at Warner Electric that you read this section very thoroughly and carefully. Your product will deliver years of reliable, trouble-free, and most importantly, safe operation if you heed the cautions and warnings outlined in this section, and follow the subsequent instructions in the remainder of this manual.

Throughout this manual two very important symbols will be used to identify hazardous and potentially dangerous situations. The symbols are the electrical shock indicator and the exclamation point. Both are always surrounded by a triangle as shown.



The electrical shock symbol shown to the left is used to indicate situations where ELECTRICAL SHOCK hazards may exist. These warnings must be followed to ensure that YOU avoid electrocution, which could result in serious injury or death.



The exclamation point symbol shown to the left is used to indicate situations other than electrical hazards, which may be potentially dangerous to either YOU or to the product. Follow these warnings carefully to avoid injury to you and damage to the product.

The following indicates a partial list of precautions, which must be followed to ensure safe operation of the unit. Other more specific precautions are indicated in the appropriate sections of this manual. As you read through the manual, pay particularly close attention to these cautions and warnings as they could **save your life!**



Dangerous voltages, currents, temperatures, and energy levels exist within this unit, on certain accessible terminals, and at the AC motor. NEVER operate the unit with its protective cover removed! Caution should be exercised when installing and applying this product. Only qualified personnel should attempt to install and/or operate this product. It is essential that proper electrical practices, applicable electrical codes and the contents of this manual be followed strictly.



AC motors can develop high torque and speed. Use extreme caution during development of applications and integration into your system. Sudden motor motion may occur during execution of software programs. All software should be verified for proper operation before integration into your system. The motor may continue to rotate upon removal of power to the unit. It is your responsibility to ensure that no dangerous motion occurs due to gravity loading or free-running motors upon unit shutdown. Fail-safe brakes may be interfaced to the unit to prevent such dangerous conditions.



AC motors can have temperatures of up to or exceeding 100° C. Use caution when handling the motors.



Dangerous high voltages exist in this product. Be certain the power has been removed for a minimum of 5 minutes before any service work or circuit board configuration changes are performed.



Temperature of the heatsink or the unit could be hot to the touch. Caution should be used when determining the temperature.



Secure mounting and proper grounding of both the AC motor speed control and the AC motor are essential for proper operation of the system.



It is your responsibility to follow the appropriate federal, state, and local electrical and occupational safety codes in the application of this product.



NEVER wire the unit with the power on! Serious injury as well as damage to the unit may result.



NONE of the inputs to the unit are to be used as EMERGENCY STOP in ANY application.



Although activation of certain inputs will discontinue motion or disable motor current, these are NOT designed as fail-safe E-STOP inputs. Relying exclusively on inputs to the unit to cease motion which could cause dangerous conditions is a violation of Machine Safety Codes (ref. IEC 204-1). Other measures such as mechanical stops and fail-safe brakes must be used in these situations.

2.0 - Introduction to This Manual

This Adjustable Speed Drive is part of a family of drives that provide AC motor speed control in a wide variety of industrial and commercial applications. Models are available for 1 to 20 HP applications.

This manual provides a checklist, drawings, specifications and pre-installation information to help you select the right equipment and properly install your NEXTDRIVE™ SC4000 Series Adjustable Frequency Drive.

To assure successful installation, thoroughly read and understand the material presented in each section before you attempt to install the drive. If this is your first installation, we suggest you read each section in the sequence presented since they assume you know the material presented previously. Once you are an experienced installer, you can use the manual as a source of reference to look up the information you need using the index as a guide.

SC4000 Adjustable Frequency Drives are designed to provide adjustable speed control of three phase motors. The microprocessor based pulse width modulated (PWM) drives have standard features, which can be programmed to tailor your drive's performance to suit your needs.

Note that throughout the manual, titles of sections and other SC4000 manuals are shown in *Italics*. Items in ***bold Italics*** are important. Items in **bold without Italics** are parameters or commands that appear on the LCD of the keypad on your SC4000 Adjustable Frequency Drive.

If you have any questions or comments, please feel free to contact us. Warner Electric Application Engineering can be reached at 1-800-787-3532. In addition you can contact us through our web site at: www.warnernet.com.

3.0 - Installation

This section of the SC4000 Instruction manual provides pre installation information, an installation check list, a quick start installation guide, drawings, and specifications to help you select the right equipment and properly install your SC4000 Adjustable Frequency Drive.

To ensure successful installation, thoroughly read and understand the material presented in this section before you attempt to install the drive. If this is your first installation, we suggest that you read this manual in the sequence it is presented. Once you are an experienced installer, you can use this section as a source of reference and look up the information you need using the index as a guide.

3.1 - Pre Installation

This part of the *Installation* section of this Instruction Manual provides guidelines to consider *before you install your drive*:

- ? Handling of Drive After Delivery.
- ? Where to Locate Drive.
- ? Application Considerations.
- ? Input Line Considerations.
- ? Output Power Considerations
- ? Analog.

3.2 - Handling of the Drive After Delivery

Although every precaution is taken to ensure that the unit is in good condition, take a moment to inspect your drive after it arrives at your site.

1. Inspect the shipping container for evidence of rough handling immediately after the unit arrives. Report all damage to the freight carrier and Warner Electric or your Warner Electric sales representative.

2. Carefully unpack the drive, taking care to save the shipping container and any packing material should you need to return the unit at a later date. Verify that the items on the packing list or bill of lading agree with your order.

3. If you are not installing the drive right away, store the drive in a clean, dry, area where the ambient temperature is between -4 to 158 F (-20 to 70 C) and less than or equal to 95% humidity (non-condensing). Make sure the drive is not subject to a corrosive atmosphere (such as H₂S).

Large frame SC4000 Adjustable Frequency Drives may require more than one person to move from one location to another. Observe proper lifting techniques to avoid injury when handling heavy electrical equipment.

3.3 - Where to Locate Drive

Consider the following:

1. Locate the drive in an area consistent with the environment specifications listed in the Specifications section of this manual.

2. Standard SC4000 NEMA 1 drives can withstand an ambient temperature of 108°F (40°C) up to 3,300 feet (1000 meters) above sea level. If you install the drive in an optional enclosure, the maximum temperature must not be exceeded.

If you install an enclosure at temperatures exceeding these values, you must derate the unit as follows:

For every 9°F (5°C) over the rated temperature you must derate the SC4000 current ratings by 10%. However, do not exceed a maximum of 131°F (55°C) under any circumstances.

In addition for every 1000 feet (300 meters) above the rated altitude, you must derate the SC4000 current ratings by 2%.

3. Refer to the illustrations in the Drawings section of this manual for the mounting dimensions of each enclosure.

4. Make sure there is plenty of ventilating space surrounding the drive. Refer to the illustrations in the *Drawings* section of this manual for ventilation clearances.

3.4 - Application Considerations

When you plan your SC4000 Adjustable Frequency Drive installation, consider its application. Different applications, such as industrial process control and HVAC system control, require different drive options, motors and software configuration.

The following is a list of items you should keep in mind when you plan the installation.

1. Remember you must have an input line impedance of at least 1% and not over 5% for proper drive operation. You should calculate the input line impedance to determine whether a 1 % input reactor is required. Refer to the discussion on Input Line Considerations later in this section for more details on determining input line impedance.

2. Order a 3% or 5% input line reactor to improve input line harmonic distortion as required. Refer to the discussion on Input Line Characteristics later in this section for more details on harmonic distortions.

3. A circuit breaker is usually required for disconnecting the motor from the power source.

3.5 – Quick Start Guide

Power Connections

(Reference Section 3.11.1)

1. Connect motor and power as shown in Section 3.11.1.

2. Line fusing is required and must be of the specified type/value as shown. If line impedance is less than 1% at the drive terminals select a 3% line impedance reactor as shown in the Table 3.1b.

3. If required, connect the optional Dynamic Braking resistor module as shown. The drive has an approved electronic overload protective feature based on motor full load nameplate data.

4. Branch circuit protection is required based on the AC line input current rating and should be selected in accordance with power system wiring practices and local and national codes.

Required I/O Terminal Connections

(Reference Section 3.11.1)

1. Connection between terminals 6 and 7 is **required** for any drive operation. Opening this connection results in a drive fault. If the drive is running at the time “external trip” is displayed.

2. Install optional DB resistor thermal sensor, if used, and any interlocks that may be required in the application.

3. Connection between terminals 6 and 8 is also **required** to run the drive. Install any stop interlocks that are required. Opening the stop circuit when running will cause the drive to ramp to a stop.

Initial Power up (Reference Section 5.1)

Before applying power to the drive, insure that all safety devices are in place and that the motor can rotate freely. Apply power to the unit. The display should indicate <Warner SC4000> for a period of 5 seconds and then the ready display which will indicate the default values of <Spd Set 100 RPM> and <Max Trq 150% >.

Keypad/Terminal/ Serial Operation

(Reference Sections 5.2, 5.3, and 6.0)

The drive may be operated from any one of three sources, the keypad, I/O terminals or serial input as selected from Cmd Src (Pr402). The drive will not reverse unless Fwd/Rev (Pr 407) is selected for the desired function.

1. If keypad source is selected and speed changes are to be entered from the keypad no further I/O terminal connections are required to run the drive. Proceed to the drive setup section.
2. If terminal source is selected the drive will not respond to the keypad inputs for Run, Jog, FWD or Reverse. These functions will be available from the I/O terminal as shown. If the drive speed selection is to be from the keypad then proceed to the setup section. The drive will not respond to a speed command from an analog source unless Setpt Src (Pr 401) is switched from Keypad to Analog. If the source is a voltage input from a potentiometer then proceed to the setup section. If it is from a current input then (remote) must be selected by utilizing terminal 13.
3. For operation from a serial source refer to Section 6 – Serial Communications.

Drive Setup (Reference Section 5.3)

1. Go to the Setup: 100 menu and enter motor nameplate data for Motor Power (Pr 101), Motor Volts (Pr102), Motor Amps (Pr103), Motor Speed (Pr104), and Rated Frequency (Pr105).
2. Once the nameplate data has been entered, “Auto Tune” the drive by selecting Autotune (Pr106) then pressing the SCROLL/CHANGE button. The display should read; “Autotuning Drive ...”. When autotune is complete it will switch to the “ready” display indicating <Set Spd 100RPM> on the top line and <Max Trq 150%> on the bottom line.
3. If a different set speed is desired refer to Section 5.2 Operating the Drive from the Keypad. To operate the drive from the keypad it is required that the ready display is shown. The display will automatically return to the ready display from the menu or parameter display if idle for 30 seconds. To return to the ready display from the menu or parameter displays depress the Run button once. Note once the ready display appears the drive will now accept a keypad run command.
4. Press the RUN button, the display will change to the run display indicating actual motor speed and torque and the motor should begin to rotate. Observe the motor. Is it moving in the correct direction? If the direction is not correct, stop the drive by pressing the STOP button, remove power, and reverse the connection of any two motor leads.
5. Check the motor’s operation throughout the normal operating speed range and any control circuitry to ensure proper operation. If any unusual or abnormal operation exists refer Section 7.0 - Fault Indication Troubleshooting.

3.6 - Motor Selection

Careful consideration of the proper motor is essential to obtain optimum performance from your drive. Contact your Warner Electric sales representative or distributor for additional assistance and/or literature regarding motor selection and other aspects of drive applications.

1. Your SC4000 drive is designed to be connected directly to a single, NEMA design B, three phase AC induction motor. The motor must be selected and applied so that the average operating motor current and horsepower do not exceed the continuous current and horsepower ratings of the drive. The intermittent operating current must not exceed the intermittent current rating of the drive.

2. Consider the effect of speed on the cooling capacity of the motor. As you slow down some types of motors (such as a Totally Enclosed Fan Cooled [TEFC]), the fan turns slower which reduces airflow to the motor. These types of motors may overheat if you operate them for extended periods of time at their rated torque and a reduced speed (less than 50% of full speed). Choose a motor that matches the expected duty, torque range and speed. Warner Electric can supply Inverter Duty motors especially designed for variable speed applications.

3. Multiple motors may be operated by an SC4000 drive if:

? Total current from all motors does not

exceed the current rating of the SC4000.

- ? Individual motor overload protection is supplied.
- ? All motors must start and change speed together.

If you configure the drive to operate above 60 Hz, the motor may operate above its nameplate speed. Personal injury or equipment damage may exist when you operate the motor and driven machines above their rated speed. Make certain that all guards and shields are in place before operating at any speed. Refer to the motor manufacturer to verify safe motor speed.

3.7 - Input Line Considerations

All wiring must comply with the requirements of the National Electric Code (NEC) and/or other codes as required by the authority having jurisdiction over the installation. The installer must ensure that the electrical connections at the site conform to the connection diagrams shipped with the drive.

Note: Make sure you use the most recent version of the codes when you install your SC4000 drive.

The following table provides an overview of the SC4000 AC drive's electrical specifications. Detailed specifications are provided in Appendix A, SC4000 General Specifications.

Table 3.0 - Electrical Specification Overview

Model No.	Motor		Input			Output			Ambient Max °C	Overload Capacity	Enclosure
	HP	Volts	Volts 3 Ø	Hz	Amps RMS	Volts 3 Ø	Hz	Amps RMS			
SC4201-0100	1	230	200-240	50/60	4	3-230	0.06-400	3.6	40	150%/1 min.	NEMA 1
SC4202-0100	2	230	200-240	50/60	7.5	3-230	0.06-400	6.8	40	150%/1 min.	NEMA 1
SC4203-0100	3	230	200-240	50/60	10.6	3-230	0.06-400	9.6	40	150%/1 min.	NEMA 1
SC4205-0100	5	230	200-240	50/60	16.7	3-230	0.06-400	15.2	40	150%/1 min.	NEMA 1
SC4207-0100	7.5	230	200-240	50/60	24	3-230	0.06-400	22	40	150%/1 min.	NEMA 1
SC4210-0100	10	230	200-240	50/60	31	3-230	0.06-400	28	40	150%/1 min.	NEMA 1
SC4401-0100	1	460	380-480	50/60	2	6-460	0.06-400	1.8	40	150%/1 min.	NEMA 1
SC4402-0100	2	460	380-480	50/60	3.8	6-460	0.06-400	3.4	40	150%/1 min.	NEMA 1
SC4403-0100	3	460	380-480	50/60	5.3	6-460	0.06-400	4.8	40	150%/1 min.	NEMA 1
SC4405-0100	5	460	380-480	50/60	8.4	6-460	0.06-400	7.6	40	150%/1 min.	NEMA 1
SC4407-0100	7.5	460	380-480	50/60	12.1	6-460	0.06-400	11	40	150%/1 min.	NEMA 1
SC4410-0100	10	460	380-480	50/60	15.4	6-460	0.06-400	14	40	150%/1 min.	NEMA 1
SC4415-0100	15	460	380-480	50/60	25	6-460	0.06-400	21	40	150%/1 min.	NEMA 1
SC4420-0100	20	460	380-480	50/60	32	6-460	0.06-400	27	40	150%/1 min.	NEMA 1

3.7.1 - Input Line Conductor and Branch Circuit Overload Protection Selection

Use a combination of the following guidelines to choose the correct input line conductors and proper branch circuit overload protection:

Note: Select the input line conductor size and branch circuit overload protection in accordance with applicable code requirements.

? The input line and branch circuit overload protection must be rated for the input voltage and current stated on the nameplate of the drive.

? For runs over 300 feet, consider the recommended minimum wire size listed in Table 3.1a.

? In addition, consider the wire size capacity of the input line terminals:

1 to 10 HP Maximum wire size is #10 AWG
 10 to 20 HP Maximum wire size is #8 AWG

? The input line conductors must be made of copper with a temperature rating of at least 167 F (75 C).

? The power terminal tightening torque range is 16-18 in. lbs. on terminals L1, L2, L3, T1, T2, T3, and the ground lugs.

3.7.2 - Grounding Connections

For personal safety and reliable equipment operation, firmly connect each chassis to earth ground as shown in the connection diagrams in the Drawings section of this manual.

The SC4000 chassis ground conductor should be the same size as the input line conductors or sized according to electrical code requirements. Use a copper or aluminum conductor.

Connection to a grounded conduit does not provide an adequate equipment ground.

Make sure that all operators control stations and motor frames are adequately grounded.

3.7.3 - Input Line Impedance

You must ensure that the input line power has an impedance of at least 1% and less than or equal to 5% equated to drive size for proper operation. Damage to the drive may occur if the source impedance is less than drive 1%. If the source impedance is more than 5%, the drive may not provide rated output voltage.

Actual input current varies considerably in response to the efficiency and power factor of the motor connected to your drive and the impedance of the power source.

Since power source impedance has an effect on the harmonic content of the input current, the amount of impedance affects the value of the input line current.

The value of source impedance is expressed as a percent of the effective impedance of the drive.

To determine the source impedance as a percent of the effective impedance of the drive, you must know:

- ? The short circuit capacity of the power source at the drive's input power terminals.
- ? The full load (output) current rating of the drive (found on the nameplate)

The following calculation provides the source impedance as a percent of the effective impedance of the drive:

$$\frac{\text{FullLoadCurrent}}{\text{ShortCircuitCapacity}} * 100 = \text{Source Impedance}$$

The short circuit capacity must be at least 20 times the full load current rating (5% drive impedance) and no more than 100 times the full load current rating (1% impedance).

For example, if the full load (output) current of an SC4000 drive is 22 amps and the short circuit current capacity of the power source is 2200 amps, the source impedance is:

$$\frac{22}{2200} * 100 = 1\%$$

Since the design of a power distribution system often includes a short circuit capacity study, power distribution system drawings or other distribution system documentation may show the short circuit capacity at various points. If this data is not available, contact your Warner Electric sales representative or distributor for help on estimating or calculating short circuit current capacity.

Table 3.1a - Recommended Minimum Input Line/Output Power Wire Size

HP	Typical Current per NEC in Amps. 230V[460V]	Recommended Minimum Wire Size (AWG and MCM) to Prevent Excessive Voltage Drop (For Various Wire Run Distances in Feet) 230V[460V]					
		300 Ft.	500 Ft.	700 Ft.	1,000 Ft.	1,500 Ft.	2,000 Ft.
1	3.6 [1.8]	14 [14]	12 [14]	12 [14]	10 [14]	8 [12]	6 [10]
2	6.8 [3.4]	14 [14]	12 [14]	12 [14]	10 [14]	8 [12]	6 [10]
3	9.6 [4.8]	14 [14]	12 [14]	10 [14]	8 [12]	6 [10]	4 [8]
5	15.2 [7.6]	14 [14]	10 [12]	8 [12]	6 [10]	6 [8]	4 [8]
7.5	22 [11]	10 [14]	8 [12]	6 [10]	6 [8]	4 [6]	2 [4]
10	28 [14]	8 [12]	8 [10]	6 [8]	4 [6]	2 [6]	1 [4]
15	[21]	[10]	[8]	[6]	[6]	[4]	[2]
20	[27]	[8]	[8]	[6]	[4]	[2]	[1]

Note: Refer to Section 3.8 and 3.9 for terminal block limitations.

Table 3.1b - Required Fusing

Motor HP	Motor Volts	Input Amps RMS	Output Amps RMS	Input Line Fuse Class/Rating	Branch Circuit Circuit Breaker (Amps)*	Line Reactor 3 Phase 3%
1	230	4	3.6	CC / 20A 600V	15	PTR5013-203
2	230	7.5	6.8	CC / 20A 600V	15	PTR5013-402
3	230	10.6	9.6	CC / 25A 600V	20	PTR5013-403
5	230	16.7	15.2	T / 40A 300V	30	PTR5013-404
7.5	230	24	22	T / 50A 300V	40	PTR5013-405
10	230	31	28	T / 60A 300V	60	PTR5013-406
1	460	2	1.8	CC / 10A 600V	15	PTR5013-200
2	460	3.8	3.4	CC / 10A 600V	15	PTR5013-202
3	460	5.3	4.8	CC / 15A 600V	15	PTR5013-203
5	460	8.4	7.6	CC / 20A 600V	15	PTR5013-204
7.5	460	12.1	11	T / 25A 600V	20	PTR5013-205
10	460	15.4	14	T / 35A 600V	30	PTR5013-206
15	460	25	21	T / 50A 600V	40	PTR5013-207
20	460	32	27	T / 60A 600V	60	PTR5013-208

* Typical, refer to local and national codes for branch circuit protection guidelines. The drive has electronic overload protection.

Table 3.1c Typical Fuses and Vendors

Manufacturer	600V Class CC	300V Class T	600V Class T
Bussman	KTK – XXX	JJN – XXX	JJS – XXX
Gould	ATM – XXX	A3T – XXX	A6T – XXX

Littlefuse	KLK - XXX	JLN - XXX	JLS - XXX
------------	-----------	-----------	-----------

Note: xxx denotes fuse rating in amperes.

3.7.4 - Harmonic Distortion

As stated in the discussion on Input Line Impedance, source impedance can affect the harmonic content of the input line current. As source impedance increases, line current harmonic content decreases.

The relationship between input line impedance and harmonic voltage distortion is just the opposite of the relationship between impedance and current distortion. As source impedance increases, so does harmonic voltage distortion.

For example, if the source impedance (expressed as a percent of the effective impedance of the drive) is 1%, you will cause less than 5% harmonic distortion when you connect a single SC4000 to an undistorted power source. If the source impedance increases to 5%, the resulting harmonic distortion is less than 10%.

Contact your Warner Electric sales representative or distributor for assistance in estimating harmonic distortion in multiple drive installations. They can also assist in selecting a means of harmonic reduction such as line reactors.

3.8 - Input Line Routing

For 1 to 20 HP SC4000:

- ? If you use conduit - Use a separate conduit for input line conductors and output power conductors. **Never** route analog and digital wiring from any equipment in the same conduit as input or output power wiring.
- ? If you use cable trays - Use a separate cable tray for input line conductors and output line conductors. Never route analog and digital wiring from any equipment in the same cable tray as input or output power wiring.

Multiple Conductor Wiring

If multi conductor wiring is used, a separate multi conductor cable must be used for the input line wiring for each drive.

Line Fuses

Line fuses are required to remove input line voltage from the drive in the event of internal component and drive failure. Line fuses must not be used in place of branch circuit overload protection. See Table 3.1b for recommendations

Isolation Transformers

Isolation transformers can be used with SC4000 Adjustable Frequency Drives. Remember that the input line impedance must be at least 1% and not over 5% with the drive running. See the previous discussion on Input Line Impedance. Sizing should be based on continuous input RMS current rating of the drive.

Power Factor Correction

The displacement power factor at the input terminals of an SC4000 drive is approximately 0.95 at all operating speeds and loads. Therefore, power factor correction capacitors are not required and should not be installed. If capacitors for correcting the power factor of other equipment are installed too close to the drive, there may be severe damage to, or nuisance tripping of, the drive.

Standby Power Generation

Three phase standby power generators can be used with SC4000 Adjustable Frequency Drives as long as the input line impedance is within the 1 % to 5% range.

3.9 - Output Power Considerations

To comply with local and nationally recognized codes, such as the NEC, you must consider proper output power wiring when you plan your Adjustable Frequency Drive installation.

Note: Make sure you use the most recent version of the codes when you install your SC4000 drive.

Output Power Conductor and Ground Conductor Sizing:

Use a combination of the following guidelines to choose the correct output line conductors and proper branch circuit overload protection:

Note: Select the output power conductor size in accordance with applicable code requirements.

- ? The output power conductors must be rated for the output voltage and current stated on the nameplate of the drive.
- ? For runs over 300 feet, consider the recommended minimum wire size in Table 3.1.
- ? In addition, consider the wire size capacity of the output line terminals:
 - 1 to 10 HP Maximum wire size is #10 AWG
 - 15 to 20 HP Maximum wire size is #8 AWG
- ? Input line conductors must be made of copper with a temperature rating of at least 167 ° F (75 ° C).
- ? The power terminal tightening torque range is 16-18 in. lbs. on terminals L1, L2, L3, T1, T2, T3, and the ground lugs.

- ? The SC4000 chassis ground conductor should be the same size as the output line conductors or sized according to electrical code requirements. Use a copper or aluminum conductor.
- ? Connection to a grounded conduit does not provide an adequate equipment ground.
- ? Make sure that all operator control stations and motor frames are adequately grounded.

Make sure that all operator control stations and motor frames are adequately grounded.

Output Power Conductor Routing for 1 to 20 HP SC4000:

- ? If you use conduit - Use a separate conduit for input line conductors and output power conductors. Never route analog and digital wiring from any equipment in the same conduit as input or output power wiring.
- ? If you use cable trays - Use a separate cable tray for input line conductors and output line conductors. Never route analog and digital wiring from any equipment in the same cable tray as input or output power wiring.

Overcurrent Protection

SC4000 Adjustable Frequency Drives are designed to automatically provide overcurrent protection for the output power circuit if only one motor is connected to the drive and sized to match the drive.

If more than one motor is connected to the drive, each motor must have its own overcurrent protection. In addition, the combined input current rating on the nameplate of each motor must not exceed the output current rating of the drive.

Power Factor Correction

Power factor correction capacitors must never be connected to the output of the drive. They may damage the drive and would not serve any useful purpose.

3.10 - Analog and Digital Signal Considerations

To comply with the design of the drive and local and nationally recognized codes, consider proper analog and digital signal wiring when you plan your Adjustable Frequency Drive installation.

Note: Make sure you use the most recent version of the codes when you install your SC4000 drive.

External Fault Signal

Some configurations, such as an optional overload interlock relay, provide an external fault signal to the drive so the drive will not start if the relay has tripped and has not been reset.

Analog and Digital Signal Wiring

- ? 18 AWG wire size is recommended. Minimum wire size is 20 AWG, maximum is 16 AWG.
- ? One conductor per terminal for 16 AWG conductors. Two conductors per terminal at 18 AWG. Three conductors per terminal at 20 AWG.
- ? Maximum length is 500 feet.
- ? Use shielded twisted-pair cable for the analog signal conductors where indicated on the terminal block connection diagram. Typically, shielding is required for all analog input and output runs. Use a separate twisted-pair for each analog signal.
- ? All digital signal runs should also be shielded; The use of twisted-pair cable is recommended.
- ? Ground the shield conductor of shielded cable for input signals only. Output signals should not be grounded at the drive end of the cable but should be grounded at the device.
- ? The analog and digital signal conductors must be made of copper with a temperature rating of at least 167 °F (75 °C).

Analog and Digital Conductor Routing for 1 to 20 HP SC4000

If you use conduit, use separate conduit for input and output power and SC4000 control wiring, up to the SC4000 drive.

- ? If you use cable trays: Never route analog and digital wiring from any equipment in the same cable tray as input or output power wiring.

Separate analog and digital wiring for your SC4000 drive from other control equipment wiring using a metal tray divider or keeping the conductors at least 2 inches apart.

Trays containing analog and digital wiring should be separated from trays containing low voltage (up to 30 volts) power wiring by at least 9 inches.

Trays containing analog and digital wiring should be separated from trays containing medium voltage (between 30 and 150 volts) power wiring by at least 18 inches.

3.11 - Connection Diagrams

3.11.1 – Power Terminal Connections

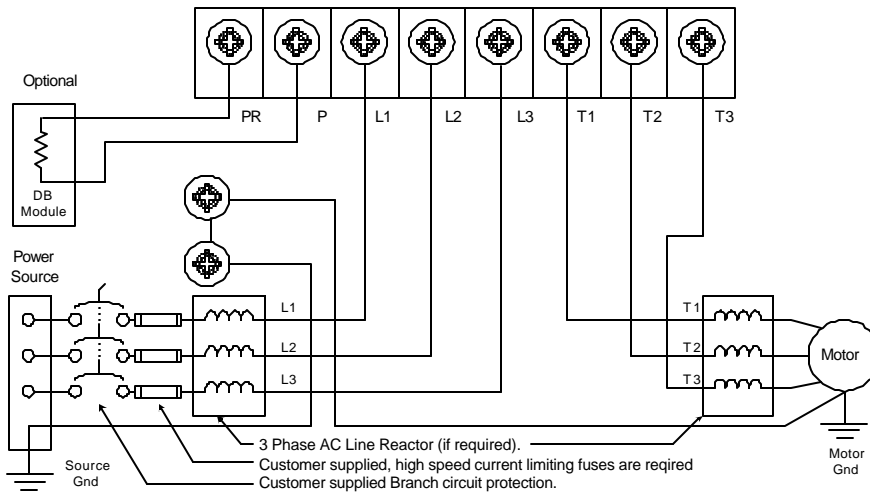

1 - 5 HP

Connections for the motor, power and dynamic braking are on the lower terminal strip. First, connect the motor to terminals T1, T2, and T3 then connect ground to one of the ground terminals on the left side of the unit. If a dynamic braking resistor is required, it should be connected now between terminals PR and P. Once the motor and DB resistor are connected, connect input power to L1, L2, and L3. Phasing is not important. A ground connection is provided on the left side of the unit for earth ground. If the direction for forward needs to be changed, reverse two of the phases connected to the motor. The connections for 7.5 to 20 Hp is shown below.

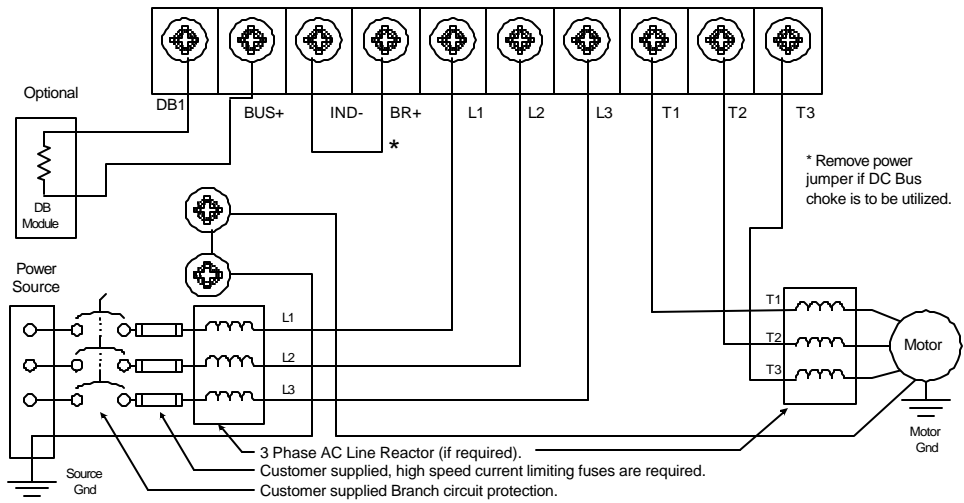

7.5 – 20 HP

3.11.2 - Analog Input Connections

There are two analog inputs, a current input and a voltage input. The current input (Remote reference) accepts a 0 - 20 mA signal, the voltage input (Vin) accepts either a 0 to +10V signal or a -10 to +10 V signal. (-10 V is not available on the drive and must be supplied externally). The voltage input can be configured using the keypad software I/O menu. See Section 5.4.5. The current input is connected as shown in the following diagram. (All connections shown below are factory defaults)

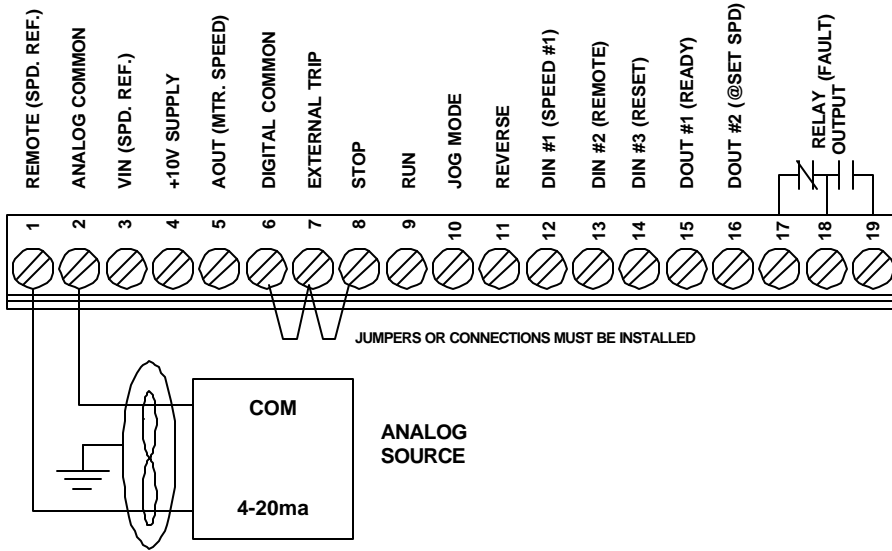

If a potentiometer is to be used it can be connected in the following ways. The first is if the +10V reference is used and the input is to be unipolar (the drive direction does not reverse).

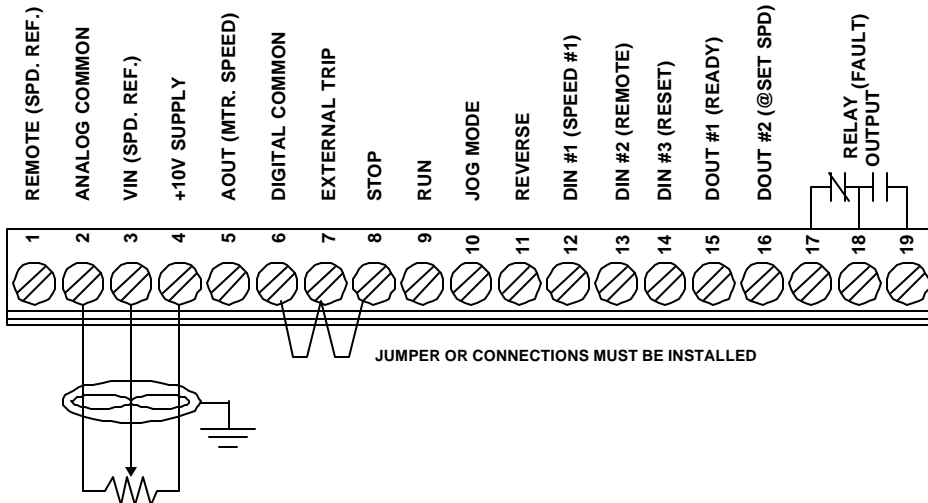

If a bipolar or a -10 to +10V source is to be used to control the motor speed, in either direction of rotation, it

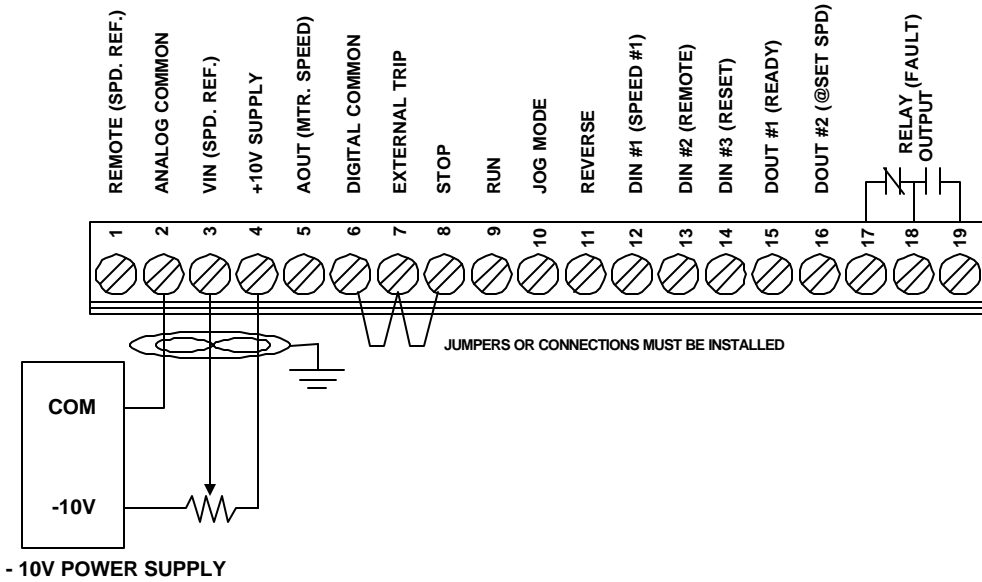

can be connected in one of the two following ways.

Other configurations and sources may be compatible. If another configuration is to be used contact Warner Electric Applications department for further information or compatibility.

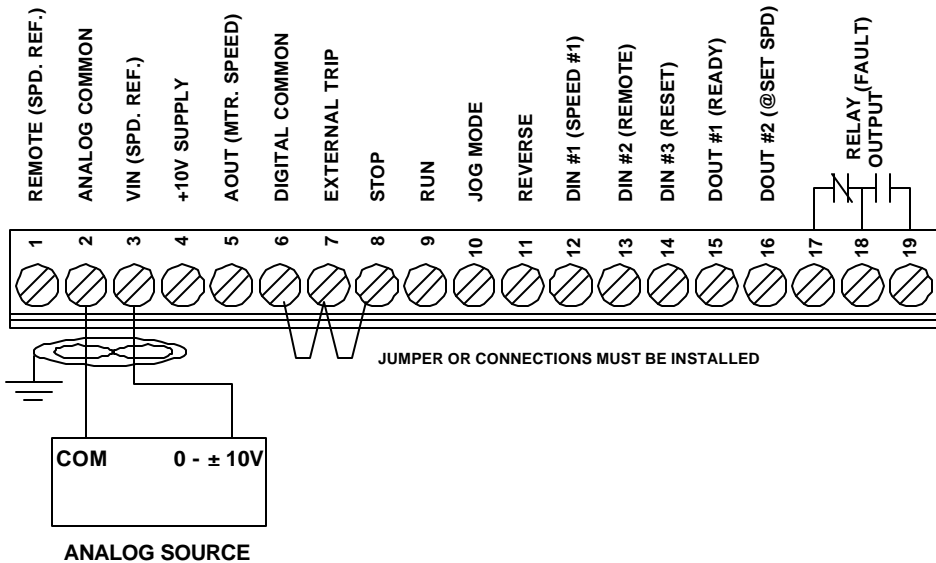

3.11.3 - Digital Input Connections

The digital inputs are “sinking” type inputs, in other words, the inputs must be switched to ground or the common of the drive or supply. The drive may be started with a 2-wire configuration (start/stop switch) or a 3-wire configuration (momentary start switch and momentary stop switch or button). See the following drawings for connections for both.

3 Wire Run-Stop

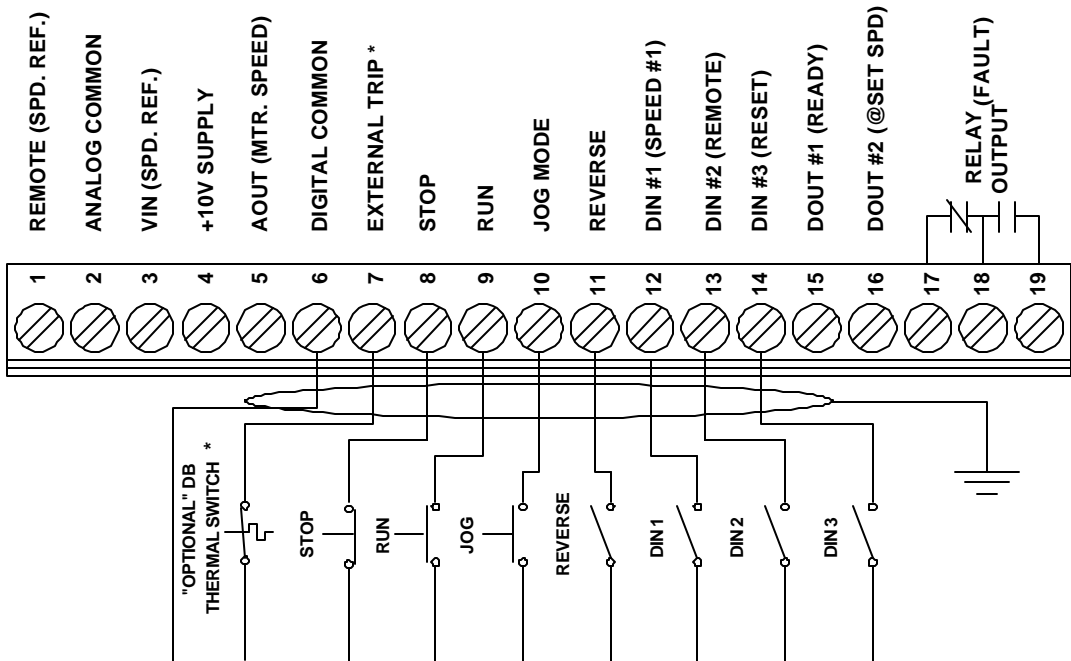

* Jumper between Digital Common (terminal 6) and External Trip (terminal 7) is required if no external trip circuit is used.

2 Wire Run-Stop

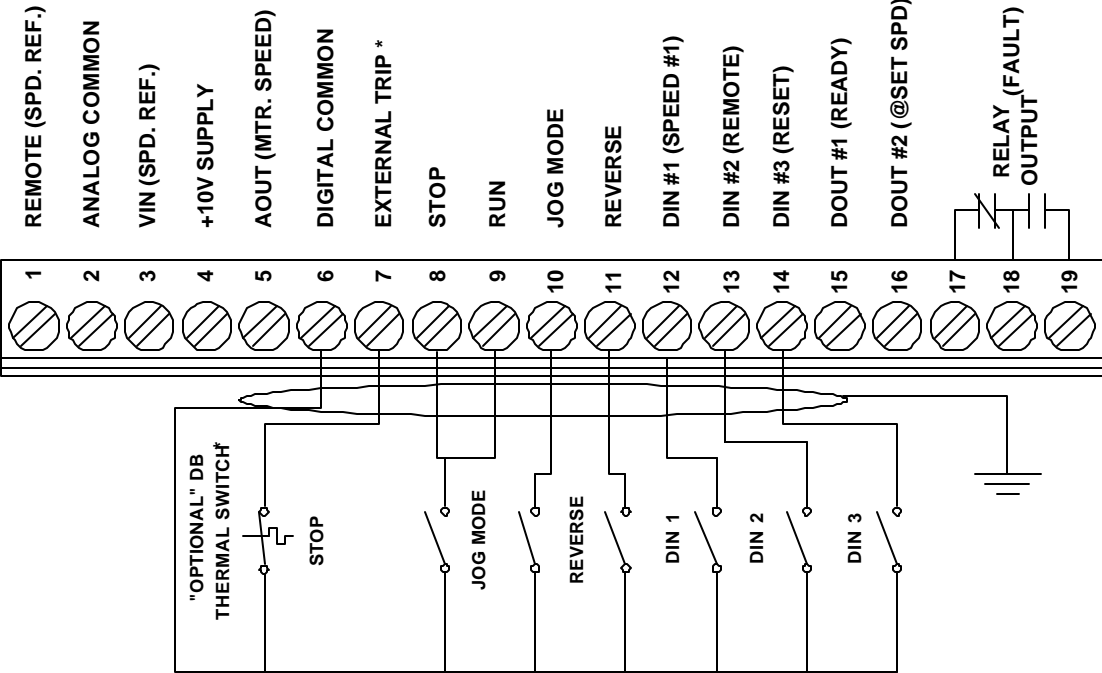

* Jumper between Digital Common (terminal 6) and External Trip (terminal 7) is required if no external trip circuit is used.

Digital inputs Din1, Din2, and Din3 can be configured for a number of functions. See Section 5.9 Parameter Table for the possible functions and defaults for these inputs.

3.11.4 - Digital Outputs / Relay Connections

The digital outputs and the relay, like the inputs, can be configured to activate by several different functions. Please consult the parameter table for the functions that are available to these I/O points. The following diagram shows examples of how the outputs can be used to drive control relays.

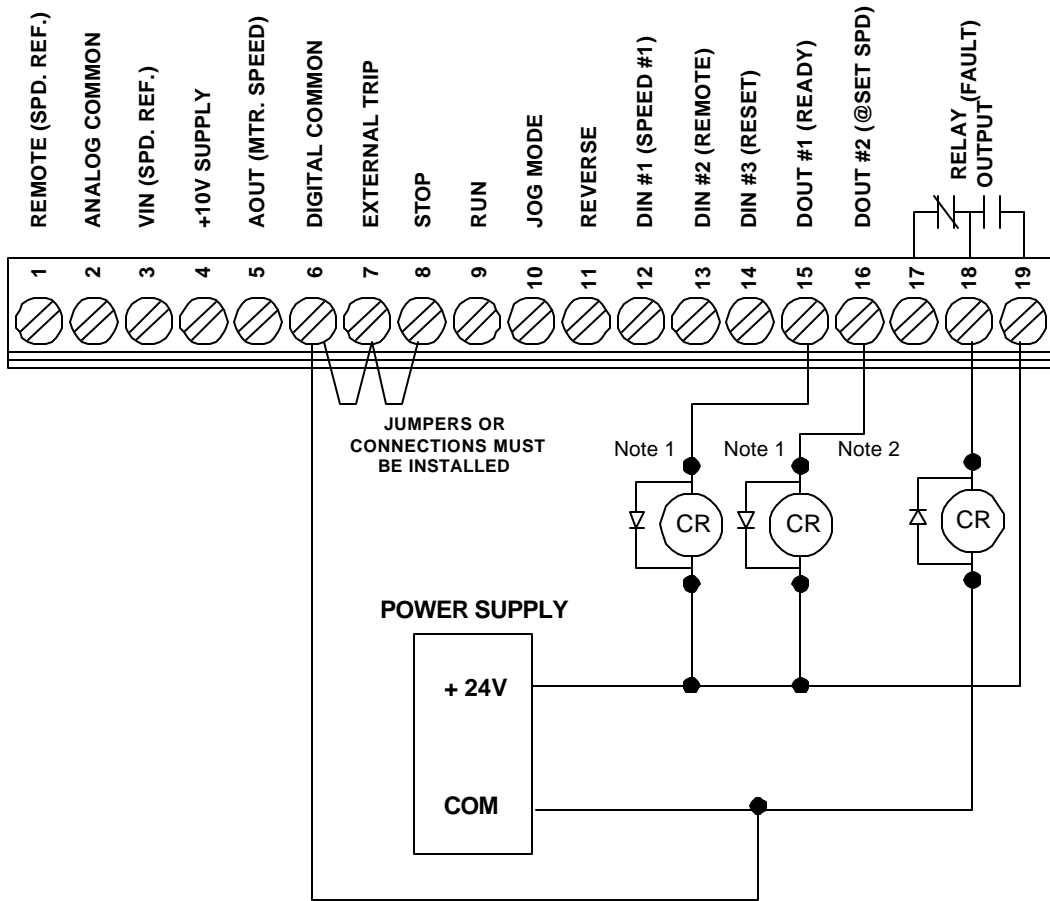

Note 1: 24 Vdc Control Relay, 25 mA maximum.

Note 2: 24 Vdc Control Relay, 0.5 A maximum (activates on a fault)

3.12 – Outline Drawings

Figure 3.1 - Dimensions for 1, 2, 3, and 5 HP frame Size

Dimensions are in millimeters (inches)

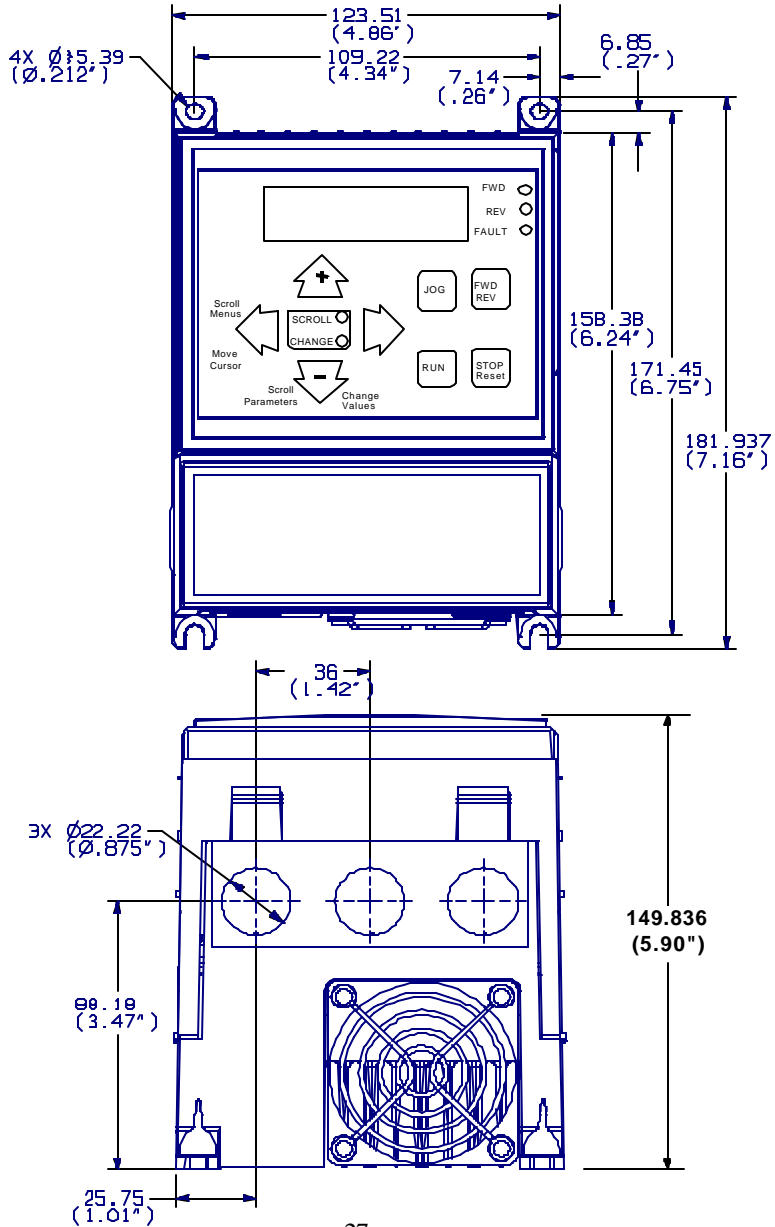

Figure 3.2 - Dimensions for 7.5 and 10 HP frame Size

Dimensions are in millimeters (inches)

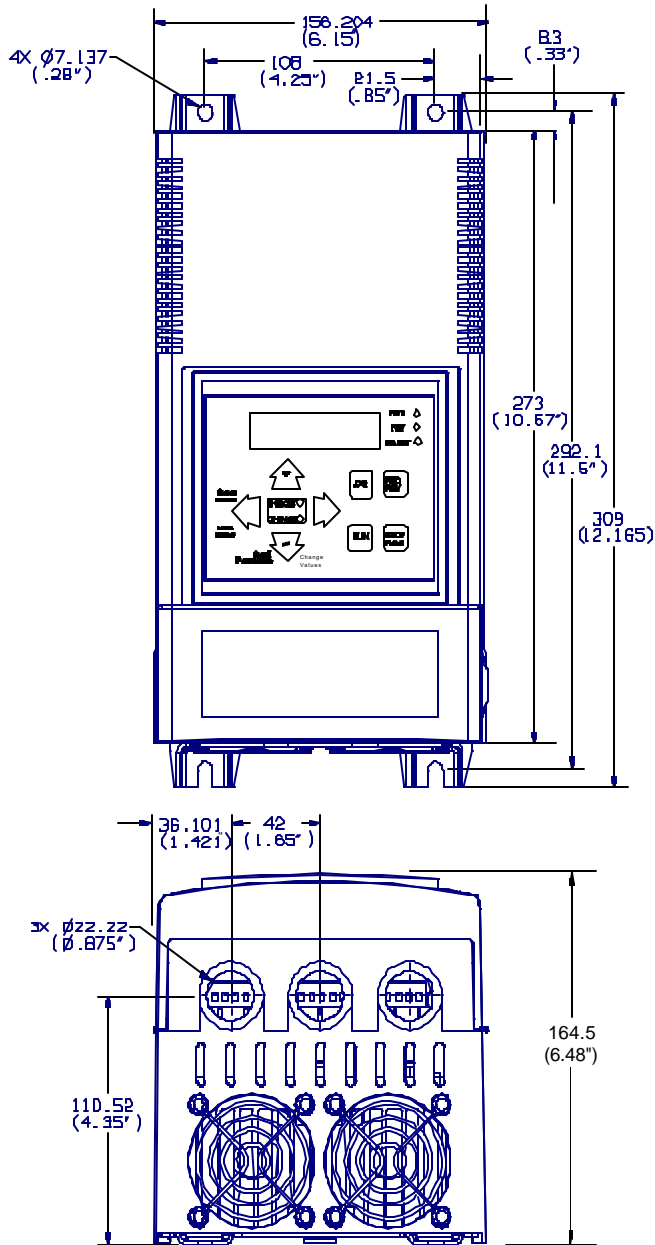
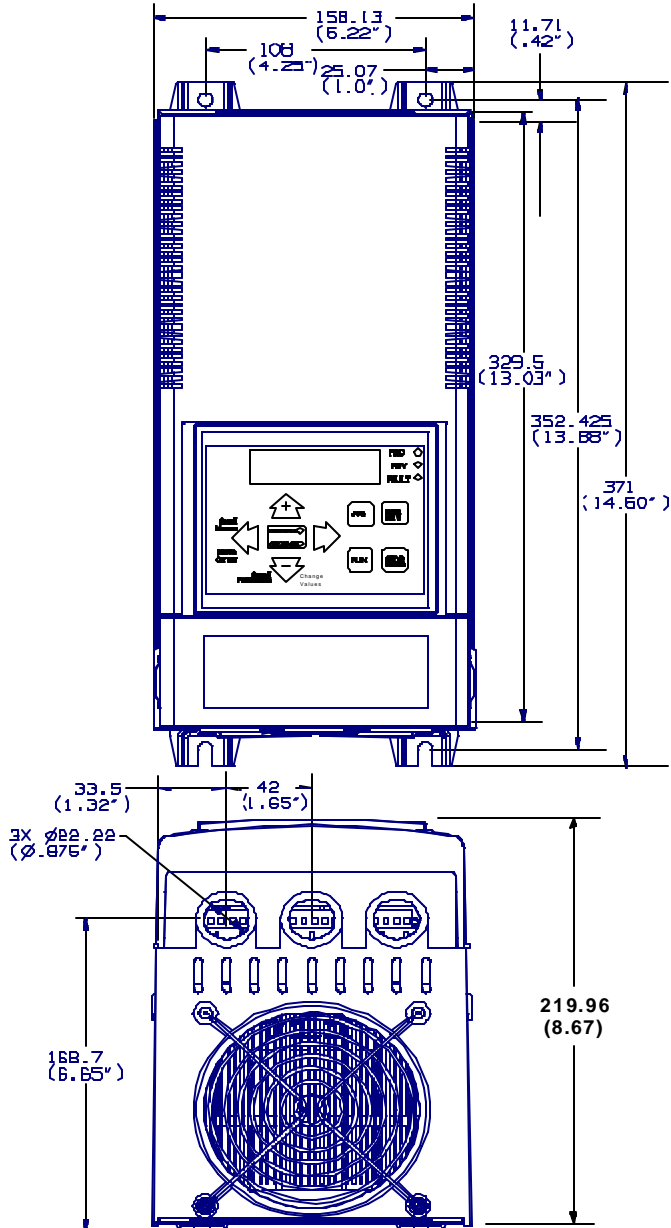

Figure 3.3 - Dimensions for 15 and 20 HP frame Size

Dimensions are in millimeters (inches)



4.0 - Specifications

General Specifications

It is your responsibility to check your installation to make sure it meets the conditions stated in these specifications before you install your Adjustable Frequency Drive. Operation of the drive outside of these specifications will void your warranty.

Output Frequency Range

0 to 400 Hz

You must make certain that the motor and associated equipment are capable of operating safely, and that protective guards are in place, before you operate your drive above 60 Hz.



Warning! Do not operate motors above their nameplate rating. Serious injury and equipment damage may result.

Input Line Conditions

- ? Three phase 240 VAC, three phase 480 VAC, or single phase 240 VAC ($\pm 10\%$). Single phase 480 VAC ($\pm 10\%$) on 1 and 2 HP units only.
- ? Input line impedance - 1% to 5%. You must purchase a 1% input line filter if you calculate or measure input line impedance less than 1%.

- ? Line Distortion - The harmonic voltage distortion of the input power line should be limited to 10% or less including distortion caused by the drive(s). (See IEEE Standard 519.)
- ? Input phase voltage unbalance less than 3% (per IEEE Standard 446).

Single phase input protection – The drive will safely run on single phase input power until the input current rating of the drive is exceeded. The input current rating must be derated by 50% for all drives except the 2 HP, 240 VAC, unit (SC4202) when single phase 240 V power is supplied. The 2 HP, 240 VAC unit is fully rated for single phase or three phase application.

- ? If single-phase power is applied to the drive the drive automatically limits the output current as required. 1 and 2 HP units are fully rated to 100% output current. 3 HP units are limited to 70% of output current. All other units are limited to 50% of output current.
- ? Drive insensitive to line phase sequence.
- ? Suitable for use on a circuit capable of delivering not more than 65K RMS symmetrical amperes, 480 volts maximum.

Input Line Transients

- ? The drive is protected and operational for line transients to ANSI C62.41 (formerly IEEE 587) and IEC 801.
- ? The drive is protected (but may trip) for severe or prolonged transients per IEEE 446.

Operator Interface

The SC4000 operator interface consists of:

- ? An LCD display (two rows of 16 characters per row) and keypad.
- ? Operator can display operating conditions, parameter settings, or English language diagnostic messages on the LCD.
- ? Operator can change the settings of a pre-defined list of parameters.
- ? Operator can Issue Run, Jog, Stop, Forward, and Reverse commands and change speeds using the keypad. Keypad can also be set for remote start and speed change.

Digital Inputs

Dry contact closure. Protected from steady state overload of up to +25V/-5VDC. No isolation from internal logic supply is provided.

Digital Outputs

One relay contact closure output is provided. The contacts are rated at 120 VAC, 0.5 amp resistive load (24 VDC, 0.5 amp).

Analog Inputs

0-10 VDC or 4-20 mA DC current loop. Input impedance greater than 100k ohm for voltage inputs; 250 ohms for current loop input. Protected from steady state overload of up to +25 V / -5 VDC. No isolation from internal logic supply is provided.

Terminal Block

The SC4000 terminal block description is summarized in table 4.1 below:

Table 4.1 - SC4000 Terminal Block Description

Terminal	Name	Terminal Description
1	Remote Spd Ref	Analog current input (8 bit) 0 to 20 mA. Input impedance is 250 ohms \pm 5 % and is protected from loads of -5V to +25V. Refer to PR601, PR602, and PR603 for Programming functions.
2	A COM	Analog reference common.
3	VIN	Analog voltage input (8 bit) -10V to +10V. Input impedance is >100 K ohms. The input is protected from loads of -5V to +25V. Refer to PR607 for Programming functions.
4	+ 10 V	+ 10 V (10 mA maximum)
5	A out	Programmable analog output. 0-10V (8 bit accuracy). Maximum output current is 10 mA.
6	D COM	Digital Input Common.
7	Ext Trip	External trip input. This input must be connected for the drive to function. It is used for attaching external devices to force a shutdown of the drive. Without this input the drive will enter a fault condition. This input must be connected to operate the drive from the keypad or remotely.
8	STOP	Stop or run enable input. This input must be connected for the drive to run. If it is not connected the drive will not run and no fault is generated. This must be connected to operate the drive from the keypad or remotely.
9	RUN	Run Input. In the 3-wire mode of operation a momentary connection of this input to digital ground (low) will cause the drive to run. In the 2-wire configuration, the input must be held low for the drive to run.
10	JOG MODE	Jog mode input. If jog mode is enabled and a run command is given, the motor will run at the jog speed until run is deactivated. If using the keypad, the motor will run while the start button is held down.
11	REV	Reverse input. If this input is open the motor will run in the forward direction. If it is closed the motor will run in the reverse direction. Refer to PR407 for mode selection.
12	Din1	Programmable Digital input one. When this input is closed it will activate its selected function. The available selections are listed in the parameter table. The default is Preset Spd1. (Preset Spd1 is selected when the input is closed) Refer to PR612 for mode selection.
13	Din2	Programmable Digital input two. When this input is closed it will activate its selected function. The available selections are listed in the parameter table. The default is Loc/Rem. (Local mode is selected when the input is open, Remote mode is selected when the input is closed) Refer to PR613 for mode selection.
14	Din3	Programmable Digital input three. When this input is closed it will activate its selected function. The available selections are listed in the parameter table. The default is Reset. (A fault condition will be reset when the input is closed) Refer to PR614 for mode selection.
15	Dout1	Digital output one. It is activated when a selected function reaches a preset level, state, etc.. The available functions are listed in the parameter table, refer to PR615. Some parameters require a level to be set. The level is set using the Dout set parameter. (Open collector transistor output rated for 25 mA maximum)
16	Dout2	Digital output two. It is activated when a selected function reaches a preset level, state, etc.. The available functions are listed in the parameter table, refer to PR617. Some parameters require a level to be set. The level is set using the Dout set parameter. (Open collector transistor output rated for 25 mA maximum)
17	Relay NC	Relay output - normally closed contact. This is the normally closed contact of a form-C relay that opens when a selected function reaches a preset level, state, etc.. The available functions are listed in the parameter table, refer to PR619. Some parameters require a level to be set. The level is set using the relay set parameter.
18	Relay COM	Relay common. Relay is rated 0.5 A at 120 VAC and 0.5 A at 24 Vdc.

19	Relay NO	Relay output - normally open contact. This is the normally open contact of a form-C relay that closes when a selected function reaches a preset level, state, etc.. The available functions are listed in the parameter table. Some parameters require a level to be set. The level is set using the relay set parameter.
----	----------	---

Analog Outputs

0-10 VDC. Output impedance less than 50 ohms. Protected from externally applied steady state overload of up to +25 V / -5 VDC. No isolation from internal logic supply is provided. Output scaling is set from 0 to 10V, with no offset. If set to speed, 0 V = 0 rpm / 10 V = Max Speed.

Analog and Digital Input and Output Signal Transient Protection

Inputs and outputs protected to IEC 801 transients.

Shock and Vibration

Will withstand shock and vibration encountered during shipping, installation and operation per ASTM D999 and MIL-STD 202E.

EMI Radiation

Drive complies with FCC part 15B of federal regulation #47 as a class A digital device when operated in a specially designed optional enclosure.

EMI Susceptibility

Drive complies with IEC 801 (Performance Criteria 1) without fault or disturbance.

Agency Standards

In addition to standards previously listed, SC4000 drives comply with the following agency standards:

- ? UL Standard 508C and 840

- ? cUL
- ? NEMA- ICS 3.1
- ? IEC - 22G

Operating Environment

- ? Ambient Operating Conditions
NEMA 1: 32 to 104 °F (0 to 40 °C).
Humidity must be less than or equal to 95% (non-condensing and non-corrosive).
- ? Cooling Air
The cooling air must be free of conductive dust, oil mist and condensation. If the cooling air contains dust and oil, clean the heat sink surface of the unit regularly. If it is not cleaned, the unit will not be able to dissipate as much heat The SC4000 drive Includes over-temperature protection, which will cause a fault and stop the drive.
- ? Storage Conditions
-4 to 158 °F (-20 to 70 °C). Less than or equal to 95% humidity (non-condensing and non-corrosive).
- ? Hazardous Environment
Must not be subject to explosive atmosphere or “Hazardous (Classified) Location” per National Electrical Code Article 500.
- ? Corrosive Environment
Must not be exposed to corrosive atmosphere, such as Hydrogen Sulfide.
- ? Solvent Withstand
Keypad will withstand common industrial solvents, such as alcohols and acids, per ASTM-896.

? Heat Dissipation

Table 4.2 – Heat Dissipation Ratings

Drive Ratings		Dissipation Into Heatsink ⁽²⁾	
Drive HP / VAC	Rated Current ⁽¹⁾	At Rated Current	At Half Rated Current
1 / 240	4.0 Amms	35 Watts	thd Watts
2 / 240	7.5 Amms	64 Watts	32 Watts
3 / 240	10.6 Amms	94 Watts	44 Watts
5 / 240	16.7 Amms	137 Watts	65 Watts
7.5 / 240	24.0 Amms	215 Watts	100 Watts
10 / 240	32.0 Amms	276 Watts	128 Watts
1 / 480	2.0 Amms	49 Watts	thd Watts
2 / 480	3.8 Amms	77 Watts	49 Watts
3 / 480	5.3 Amms	101 Watts	60 Watts
5 / 480	8.0 Amms	140 Watts	77 Watts
7.5 / 480	12.0 Amms	192 Watts	108 Watts
10 / 480	16.0 Amms	240 Watts	129 Watts
15 / 480	25.0 Amms	346 Watts	thd Watts
20 / 480	32.0 Amms	436 Watts	thd Watts

Notes: (1) UL Values, input current and 1% line impedance
 (2) Includes inverter, rectifier, and solid-state SCR

Table 4.3 - Drive Power Ratings

Drive Power Rating	3 Phase Voltage Rating	Output Rated Current 100%	Output Rated Current 150%	Input Rated Current Cont.*
1 HP (0.75 kW)	200 / 240 VAC	3.6 A	5.4 A	4
1 HP (0.75 kW)	380 / 480 VAC	1.8A	2.7 A	2
2 HP (1.5 kW)	200 / 240 VAC	6.8 A	10.2 A	7.5
2 HP (1.5 kW)	380 / 480 VAC	3.4 A	5.1 A	3.8
3 HP (2.2 kW)	200 / 240 VAC	9.6 A	14.4 A	10.6
3 HP (2.2 kW)	380 / 480 VAC	4.8 A	7.2 A	5.3
5 HP (3.7 kW)	200 / 240 VAC	15.2 A	22.8 A	16.7
5 HP (3.7 kW)	380 / 480 VAC	7.6 A	11.4 A	8.4
7.5 HP (5.5 kW)	200 / 240 VAC	22 A	33 A	24
7.5 HP (5.5 kW)	380 / 480 VAC	11 A	16.5 A	12.1
10 HP (7.5 kW)	200 / 240 VAC	28 A	42 A	31
10 HP (7.5 kW)	380 / 480 VAC	14 A	21 A	15.4
15 HP (11.5 kW)	380 / 480 VAC	21 A	31.5 A	25
20 HP (15 kW)	380 / 480 VAC	27 A	40.5 A	32

* Minimum line impedance = 1% and output rated current is 100%.

Note: Single-Phase voltage rating requires de-rating. See section 4.0 Input Line Conditions.

Table 4.4 - Dynamic Braking Resistor

Drive Model Number	Brake Assembly Part Number	Brake Enclosure WxDxH	Drive Power Rating HP (kW)	Voltage Class VAC	Minimum R _{DB} (ohms)*	Brake Res/Watts	Brake Torque Max.	Brake Torque Duty Cyc.
SC4201-01000	DBA270-56	14x5x4	1 (0.75)	200 / 240	50	56/271	200%	44%
SC4202-01000	DBA270-56	14x5x4	2 (1.5)	200 / 240	50	56/271	200%	22%
SC4203-01000	DBA270-56	14x5x4	3 (2.2)	200 / 240	35	56/271	200%	15%
SC4205-01000	DBA400-24	14x5x4	5 (3.7)	200 / 240	15	24/443	200%	13%
SC4207-01000	DBA800-17	14x5x7	7.5 (5.5)	200 / 240	10	16.2/852	200%	17%
SC4210-01000	DBA800-17	14x5x7	10 (7.5)	200 / 240	8	16.2/852	150%	13%
SC4401-01000	DBA275-230	14x5x4	1 (0.75)	380 / 480	200	230/278	174%	46%
SC4402-01000	DBA275-230	14x5x4	2 (1.5)	380 / 480	150	230/278	200%	23%
SC4403-01000	DBA275-140	14x5x4	3 (2.2)	380 / 480	100	140/274	150%	15%
SC4405-01000	DBA400-110	14x5x4	5 (3.7)	380 / 480	60	110/426	170%	14%
SC4407-01000	DBA650-72	14x5x7	7.5 (5.5)	380 / 480	40	72/648	186%	14%
SC4410-01000	DBA650-40	14x5x7	10 (7.5)	380 / 480	30	40/646	50%	10%
SC4415-01000	DBA1250-34	14x5x13	15 (11.5)	380 / 480	20	34.5/1242	200%	13%
SC4420-01000	DBA1250-34	14x5x13	20 (15)	380 / 480	15	34.5/1242	150%	10%

*Use of low inductance resistor modules is required,

Table 4.4 (cont.) - Dynamic Braking Resistor

Drive Model Number	Brake Res. (ohms) 100% Torque	Brake Res. (ohms) 150% Torque	Brake Res. (ohms) 200% Torque	Brake Res. (ohms) Minimum	Brake Watts 10% D.C.	Brake Watts 20% D.C.
SC4201-01000	254	169	128	50	60	120
SC4202-01000	127	84	64	50	120	240
SC4203-01000	85	56	42	35	180	360
SC4205-01000	50	34	25	20	300	600
SC4207-01000	34	22	17	15	450	900
SC4210-01000	25	16	12	10	600	1200
SC4401-01000	1019	679	509	200	60	120
SC4402-01000	509	339	254	200	120	240
SC4403-01000	339	226	101	140	180	360
SC4405-01000	203	135	94	80	300	600
SC4407-01000	135	90	67	60	450	900
SC4410-01000	101	67	50	40	600	1200

SC4415-01000	67	45	34	30	900	1800
SC4420-01000	50	34	25	20	1200	2400

SC4000 Model Number Description

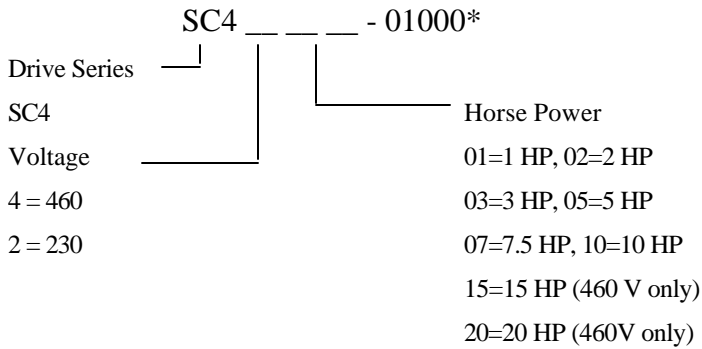

* These fields reserved for future versions of the drive.

Available Model Numbers – Enclosed Units

HP	460 VAC	230 VAC
1	SC4401-01000	SC4201-01000
2	SC4402-01000	SC4202-01000
3	SC4403-01000	SC4203-01000
5	SC4405-01000	SC4205-01000
7.5	SC4407-01000	SC4207-01000
10	SC4410-01000	SC4210-01000
15	SC4415-01000	N/A
20	SC4420-01000	N/A

5.0 - Operation

5.1 - Keypad Description

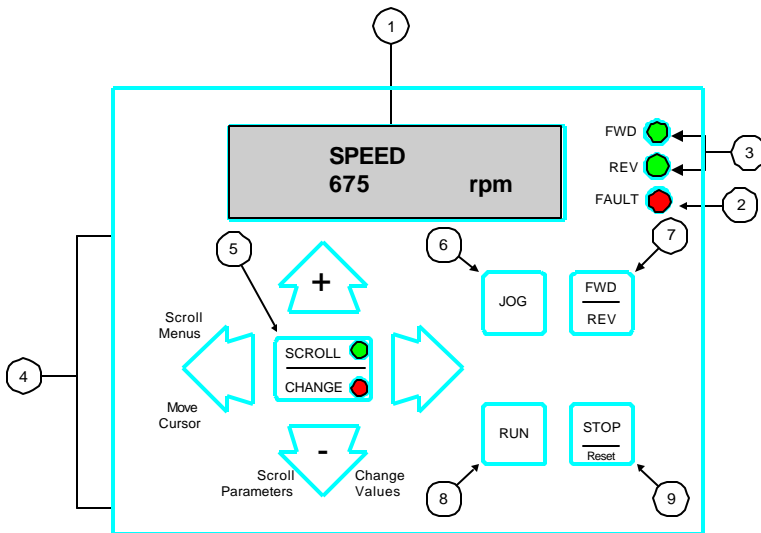

? **LCD Display** - The display on the keypad is a 16x2 display (2 lines of 16 characters) that displays information important to the drive operation. It is also used when programming the drive. The programming and the configuration of the drive are explained later in the manual.

? **Fault LED** - The fault LED is lit when a fault occurs in the drive. A list of faults is provided in Section 5.8. Section 7.0 provides descriptions of the faults and possible solutions.

? **FWD and REV LED's** - The FWD LED is lit when the drive is operating the motor in the forward direction. The REV LED is lit when the drive is operating the motor in the reverse direction.

? **Keypad Arrows** - The arrow buttons are used for navigating through the menus of the drive. They also can be used to increment or decrement the setpoint speed or to adjust the parameters that control the drive. These buttons are used in conjunction with the Scroll/Change button.

? **SCROLL / CHANGE Button** - The SCROLL / CHANGE button is used to modify the drive's mode of operation. When SCROLL is active the SCROLL LED will be illuminated. In the SCROLL mode, the arrow buttons are used to steer through the menus and parameters. If the CHANGE mode is active the CHANGE LED is illuminated then the speed, in the "run mode", or the parameter displayed can be modified.

? **JOG Button** - The JOG button is used to activate the jog mode of the drive. When the jog mode is active the motor will run at the jog speed while the RUN button is pressed. To stop the motor release the JOG button. In order to change direction, press the FWD / REV button, ? .

? **FWD / REV Button** - This button is used to select motor direction. The effect of this button may be changed in the FWD/REV parameter. i.e. The ability to change direction may be limited to certain conditions or disabled completely.

? **RUN Button** - This button is used to start the motor. In the “run mode”, the motor will run continuously. If the “jog mode” is active then this button must be held down for the motor to keep running.

? **STOP / Reset** - This button is used to stop the motor if it is in motion. It is also used to reset the drive in the event of a fault condition.

5.2 - Operation of the Drive from the Keypad

Prior to operating the drive, insure that there are jumpers on the permissive circuit going from Pin 6 to Pin 7, Digital Com to External Trip, and from pin 6 to pin 8, Digital Com to Stop.

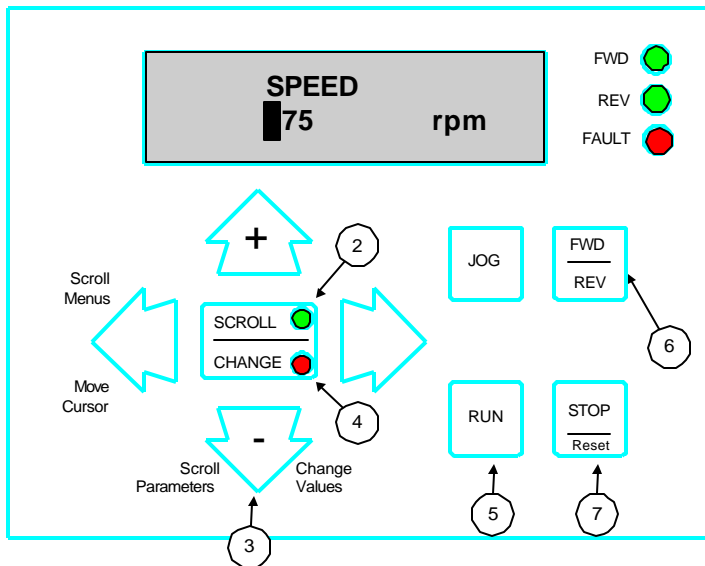

- Step 1: Apply power to the drive. The LCD should display "Warner SC4000" for 5 seconds.
- Step 2: Press the SCROLL/CHANGE button to light the CHANGE LED.
- Step 3: Press the up arrow or down arrow to change the setpoint speed until the desired speed is displayed.
- Step 4: Press the SCROLL/CHANGE button to light the SCROLL LED. This will enter the value into the keypad.
- Step 5: To begin running the motor, press the RUN button. The motor will begin to accelerate to the desired speed.
- Step 6: In order to operate the motor in the reverse direction, press the FWD / REV button. The motor will begin to ramp down and accelerate in the opposite direction. If motor does not operate as described the button may be disabled. It may be re-enabled by changing the FWD/REV parameter in the OpMode menu.
- Step 7: Press the STOP button to stop the motor from rotating.

5.3 - Menu Maneuvering

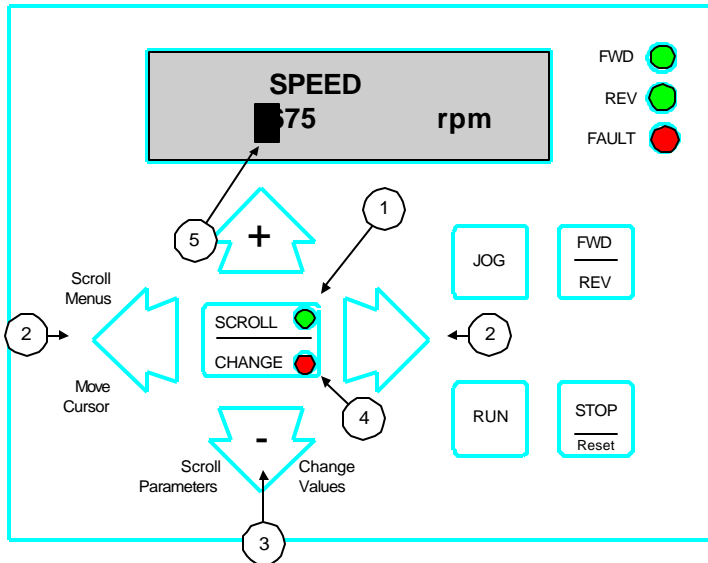

- Step 1: Press the right or left arrow to display the first menu. The menus have a wrap around feature such that the first follows the last continuously.
- Step 2: Once the desired menu is displayed, push the down arrow to scroll through the parameters in the menu.
- Step 3: When the parameter that is to be modified is displayed, press the SCROLL/CHANGE button until the CHANGE LED is illuminated.
- Step 4: The cursor may now be positioned at the value in the field that is to be changed. With the cursor positioned in the first location pressing the up or down arrow button will cause the numbers to increment or decrement. The longer it is held the faster the numbers will change.
- Step 5: When the parameter reads the value or setting that is wanted press the SCROLL/CHANGE button until the SCROLL LED is lit. Once in the SCROLL mode the value is entered into the memory of the drive.
- Step 6: To continue editing parameters in the menu, scroll up or down. To change the menu being viewed, press the right or the left arrow.
- Step 7: To exit the menus altogether, press the RUN button.

5.4 - Menu and Parameter Descriptions

In the following descriptions the number on the first line is the parameter ID. **Brief/Full** refers to the menu type, See PR219. **Run Locked** indicates that the parameter can not be changed while the motor is running.

5.4.1 - SetUp Menu: 100

The SetUp menu is used to enter motor type information (from motor nameplate) that is required to setup the drive for efficient motor operation. The parameters for the motor **MUST** be entered for the drive to operate properly.

Motor Power **101 Brief Run Locked**

Set the rated power of the motor in HP. Refer to the motor nameplate.

Motor Volts **102 Brief Run Locked**

Set the motor rated voltage in volts AC. This should match the motor nameplate.

Motor Amps **103 Brief Run Locked**

Set the motor rated amperage in Amps from the motor nameplate.

Motor Speed **104 Brief Run Locked**

Set the rated speed of the motor in RPM from the nameplate specification.

Rated Frequency **105 Brief Run Locked**

Set the motor rated frequency in Hz from the motor nameplate.

Autotune Drive **106 Brief Run Locked**

Pressing the SCROLL/CHANGE button while displaying this menu item causes all of the motor parameters listed above to be transferred from the keypad to the drive. The autotuning process takes about 10 seconds, during which the display

will read "Autotuning Drive ...". Once the autotune process is complete the menu will automatically return to the Run-operating mode.

Motor S.F. **107 Full Run Locked**

This parameter adjusts the service factor of the motor. It is used for I²T calculations.

Ext. Brake Res **108 Full Run Locked**

This parameter adjusts the wattage of the dynamic brake resistor. When a dynamic braking resistor is connected, enter the wattage value.

5.4.2 - Main Menu: 200

The Main menu sets information for the drive such as, accel, decel set speeds, etc.. It also allows engineering scale factors and configuration of the display to be set.

Maximum Speed **201 Brief Run Locked**

Set the maximum allowable speed at which the motor will run. If a higher rate is commanded, the drive will automatically limit motor speed. This parameter is in engineering units.

Minimum Speed **202 Brief Run Locked**

Set the minimum allowable speed at which the motor will run. If a lower rate is commanded, the drive will automatically set minimum speed. This parameter is in engineering units.

Acceleration Time **203 Brief**

Set the time in seconds for the drive to accelerate from zero speed to base speed when the drive is operating in speed mode. If preset speeds are being used, the rate is based upon which preset is active.

Deceleration Time **204 Brief**

Set the time in seconds for the drive to decelerate from base speed to zero speed when operating in speed mode. If preset speeds are being used, the rate is based upon which preset is active.

Jog Speed 205 Brief Run Locked

When the keypad is in Jog Mode, the maximum motor speed in RPM is set by this parameter. The Jog Mode speed command may also come from an analog input.

Jog Accel. Time 206 Brief

When the keypad is in Jog Mode, the acceleration time, in seconds, is defined by this parameter.

Jog Decel. Time 207 Brief

When the keypad is in Jog Mode, the deceleration time, in seconds, is defined by this parameter.

Speed Setpoint 208 Full

Set the operating speed setpoint of the drive when operated in speed mode. The modifications are not applied until the SCROLL/CHANGE button is pressed.

Torque Setpoint 209 Full

Set the operating torque setpoint of the drive when operated in torque mode. Modifications to this parameter do not take effect until the SCROLL/CHANGE button is pressed.

Motor Torque Limit 210 Full Run locked

Set the maximum torque limit of the drive in the forward or reverse motoring quadrants. It is set as a percentage of rated torque.

Brake Torque Limit 211 Full Run Locked

Set the maximum torque limit of the drive in the forward or reverse braking quadrants. It is set as a percentage of rated torque.

Engineering Scale 212 Full Run Locked

Scales the display by using the value entered then fixing the decimal place using the Eng Dec Pt=. All parameters using engineering units are stored as speed in RPM, which are then scaled for display and editing purposes.

Eng Dec Pt 213 Full Run Locked

This parameter controls the location of the decimal point for engineering units. If this parameter is set to 0, then no decimal point will be displayed. It set to it's maximum of 3, the number will be displayed as N.NNN. This parameter is run locked.

Eng Char 1 214 Full Run Locked

Alphanumeric character to be displayed on the screen for engineering units.
Ex. R for RPM

Eng Char 2 215 Full Run Locked

Alphanumeric character to be displayed on the screen for engineering units.
Ex. P for RPM

Eng Char 3 216 Full Run Locked

Alphanumeric character to be displayed on the screen for engineering units.
Ex. M for RPM

Top Disp 217 Full

This parameter controls the information displayed on the first line of the display in normal display mode.

Bot Disp 218 Full

This parameter controls the information displayed on the second line of the display in normal display mode

Menu 219 Brief

Sets which menus are visible to the operator. Selections are:
Full – All available menus are visible.
Brief – Displays certain parameters from the SetUp, Main, Status, and OpMode menus.

Default Factory 220 Brief
Pressing Change on this menu allows the operator to reset all parameters to factory defaults. The keypad will automatically restart causing the default parameters to take effect. The password setting is not affected by parameter recall.

Default user 221 Full
Pressing Change on this menu allows the operator to reset all parameters to user defaults, or to store the current parameters for later recall. The keypad will automatically restart causing the default parameters to take effect.

5.4.3 - Status Menu: 300

SpdSet 301 Brief
Displays the current speed setpoint in engineering units as selected (default is RPM). This is not the keypad setpoint, but rather the actual command last sent to the drive. If torque mode is selected, this parameter will not change.

Speed 302 Brief
Displays the actual motor speed in engineering units as selected (default is RPM).

Torq Setpoint 303 Brief
This parameter displays the current torque setpoint in engineering units. This is not the keypad setpoint, but rather the actual command sent to the drive. If speed mode is selected, this parameter will not change.

Torque 304 Brief
Displays actual motor generated torque as a percentage of rated torque.

Motor Amps 305 Brief
Displays the RMS current applied to the motor in amps.

Motor Frequency 306 Brief
Displays the drive output frequency to the motor in Hertz.

Motor Volts 307 Brief
Displays the AC voltage applied to the motor.

Bus Volts 308 Brief
Displays the DC bus voltage.

IxT Accumulator 309 Brief
Gives the user a view of the percentage of time the motor has been in overload, a trip will occur when the value reaches 100%.

DB Accumulator 310 Brief
Displays the current value of the Dynamic Brake Accumulator that indicates the percentage of the Braking Resistor used to slow the motor. When this value reaches 100% the drive will trip. If no dynamic brake is setup, this value will remain at 0.

Power Input 311 Brief
Displays the power input to the drive.

Power Output 312 Brief
Displays the power output to the motor.

Watt Hrs 313 Brief
Displays the energy consumed by the drive.

Hours Run 314 Brief
Displays the total time running in hour's (H) since the date of manufacture. This parameter is not reset by Factory Default.

HS Temperature 315 Brief

Displays the present heatsink temperature in degrees centigrade. Note; the heatsink fan is temperature controlled and normally off until the heatsink temperature reaches 50 °C at which time the fan will operate. It will continue to operate until the temperature drops to 40 °C. The maximum allowable temperature is 92 °C before thermal shutdown occurs.

Input Status 316 Brief

Displays the status of the digital inputs. The left most digit corresponds to Pin 7 on the terminal strip. The right most corresponds to Pin 14. A '1' indicates the input is tied to digital ground "ON" (Pin 6), and a '0' means the input is OFF, or disconnected.

Output Status 317 Brief

Displays the status of the digital outputs. The left most digit indicates the status of Digital Output 1 (Pin 15). The right most digit indicates the status of the Relay output. A '1' indicates the digital output is ON, and a '0' indicates the output is OFF. For the Open Collector outputs, ON means the output transistor is in saturation, and OFF means it is in cutoff. The NC terminal of the relay is connected to CTR when the output is ON. The NO terminal of the relay is connected to CTR when the output is OFF.

Drive Size 318 Brief

Displays the size of the drive in HP.

Version # 319 Brief

Displays the version number of the software and keypad.

Serial # 320 Brief

Displays the serial number of the drive / keypad.

Enable Scroll 321 Full

Enables the scroll capability of the Status menu. In the Status menu, up to five items may be selected for scroll display. These items are indicated by an asterisk in the upper right hand corner. Items are selected, or deselected by pressing the SCROLL/CHANGE button. If all five items are set and an attempt is made to add an item, an exclamation point is placed in the upper right hand corner to indicate the list is full. If the selection is set to N, this parameter has no affect on system operation. If it is set to Y, the Scroll Mode is active. Upon entering the Scroll Menu (Pressing Down when the top-level menu Status: 300 is displayed), the Scroll mode will be activated, and the text "Scroll Mode" will appear on the top display line. In this mode, each previously marked item will be displayed for 3 seconds. At the end of 3 seconds, the next marked item will be displayed. This pattern will continue indefinitely. To exit this mode press the SCROLL/CHANGE button. When exited, the menu remains on the currently displayed status item. When Scroll Mode is active, the idle menu timer will not time out.

5.4.4 – OpMode Menu: 400

The OpMode menu contains parameters that determine how the drive will operate. This includes parameters concerning start, stop, and run modes, keypad configurations, braking parameters and fault restart conditions.

Setpt Src 401 Brief Run Locked

Specifies the source of the local setpoint reference signal. Only the selected source is used.

Keypad - If set to Keypad, the drive derives the local setpoint reference signal from the parameter "Setpt" (P401).

Analog - If set to Analog, the drive derives the local setpoint reference signal from an analog input (TB2-2).

Cmd Src **402 Brief Run Locked**

Specifies the source of the Run, Jog, and Direction commands. The options are: Terminal, Keypad, and Serial.

Terminal - Control of the drive is through the digital inputs on the terminal strip.

Keypad - Control of the drive is through the Run, JOG and FWD/REV buttons on the keypad.

Serial - Control of the drive is through the serial port.

Start **403 Full Run Locked**

Selects the starting mode, either manual or line.

Man - If set to Man, the drive will not start automatically on power-up.

Line - If set to Line, the drive should start on power-up, provided all inputs that must be closed to keep the drive running are closed.

If the “Jog” input (TB2-15) is closed, the drive will run at “Jog” (205) speed. If the “Jog” input is open, the drive will run at the selected speed.

Run **404 Full Run Locked**

Selects the basic operational mode of the drive.

Speed - If set to Speed, the drive will operate in Speed Mode. Speed is set either through the keypad, by digital I/O, by analog inputs, or through the asynchronous serial port.

Torq - If set to Torq, the drive will operate in Torque Mode. This setting uses either “Torq Setpt” (P209) or an analog input as the requested torque setpoint. Torque Mode or Speed Mode can also be set by setting the “User” digital input (TB1-14) with “Din1” (P612-614) set to SPEED or

TORQ. In Torque Mode the amount (percentage) of torque is controlled. Motor Speed will depend on the load.

Jog **405 Full Run Locked**

The Jog= parameter controls the source for the jog speed command. It can be set to Jog Speed, or Run Speed.

Jog Speed - Uses the Jog Spd= parameter in menu 200 for the jog speed reference.

Run Speed - Uses the set speed reference for the jog speed.

Stop **406 Full**

Selects the mode of stopping the drive. It can be set to Ramp, Coast, or DC Hold.

When set to Ramp, the motor will decelerate at the selected rate until stopped. Coast allows the motor to simply coast to rest. DC Hold causes the motor to ramp to a stop. Once stopped, a DC current is applied for a specified time.

Ramp - The motor will decelerate to a stop using the appropriate deceleration time (corresponding to the setpoint, jog speed, or preset speed). This is a controlled stop.

Coast - If set to Coast, the drive is turned off right away and the motor will coast to a stop.

DC Hold - If set to DC Hold, the drive will be commanded to a stop using the appropriate deceleration time (corresponding to the setpoint, jog speed, or preset speed). Once stopped a DC current is sent to the AC motor, producing braking torque. The drive is turned off after “Hld Brake T” (P416) time. The brake will also turn off if the drive is restarted.

Fwd/Rev 407 Brief Run Locked

Motor direction can be limited by this parameter. Four settings are possible: Fwd, Always, Stopped, and Jog.

Fwd - If set to Fwd, the drive is not allowed to run in reverse, and it will ignore a reverse command.

Always - If set to Always, the drive is allowed to change direction at any time. The drive will respond immediately if the direction is changed. It will slow down and ramp to its requested speed in the opposite direction without stopping.

Stopped - If set to Stopped, the drive is only allowed to change directions when it is stopped. If the drive is not stopped, the drive will not reverse direction. It will remember the command, however, and change direction when stopped and restarted.

Jog - If set to Jog the drive will only run reverse when jogging. If the drive is not jogging, it will not run reverse. It will remember the command, however, and run reverse when set to Jog.

NOTE: If the speed source is a bipolar analog signal, the polarity of the signal determines the drive direction. The drive, however, will remember any requested change of direction.

Security 408 Full

This parameter allows you to password protect other parameters from alteration. It will accept up to 5 alphanumeric characters.

Proportional Gain 409 Full

Sets the Proportional Gain for the PI Compensation Loop. This parameter may be adjusted while the motor is operating. It controls how close to the commanded value the system will keep control.

Integral Gain 410 Full

Sets the Integral Gain for the PI Compensation Loop. This parameter may be adjusted while the motor is operating.

S-Ramp 411 Full

This parameter enables, or disables the S-Ramp generator. It can be set to Enable, or Disable. When set to Enable, the S-Ramp is enabled, and all acceleration and deceleration will be non-linear. It is used for high breakaway torque or smooth start applications.

Efficiency Optimization 412 Full

This option causes the motor to run more efficiently and saves energy. This option is primarily used with centrifugal loads. The options are enable or disable.

Inertia 413 Full

This parameter adjusts the internal gains to compensate for the inertial load on the motor.

***Catch Spin Motor 414 Full Run Locked**

With this option enabled, if the motor is moving and a Run command is given, the drive will search for the speed. Once it has found it the motor will ramp up or down to the commanded speed.

*** Not presently available**

Hold Brake Current 415 Full Run Locked

This parameter adjusts the amount of current used in the DC Hold mode. It is entered as a percentage of Motor Rated Current.

Hold Brake Time 416 Full Run Locked

The time that the DC hold current will be applied to the motor in seconds. This will only be used when the stop mode is set for DC hold.

Trip Restarts 417 Full

The Fault Trip Recovery system requires a number of times to attempt to restart the motor. This parameter controls that setting. Upon startup, the keypad reads this parameter, and saves it as a counter in RAM. The RAM copy is decremented every time a restart occurs. When the counter reaches zero, no more retries will occur. Pressing the STOP button causes the counter in RAM to be reloaded with the value of this parameter. Adjusting this parameter does not affect the RAM copy.

Restart Time 418 Full

This parameter sets the length of time, in seconds, between a fault occurring, and the recovery attempt. It may be adjusted at any time, and takes effect at the next fault.

5.4.5 - Preset Menu: 500

Preset Parameter Menu Descriptions (P5xx)

Presets are activated and selected with the digital inputs. This menu contains preset speeds, acceleration rates, and deceleration rates. In addition, skip bands are modified from this menu.

Presets are active any time the drive is operating from a speed reference. This menu only displays P501-503 unless the Menu parameter is set to Full.

Pr Spd 1	P501	Pr Spd 5	P513
Pr Accel 1	P502	Pr Accel 5	P514
Pr Decel 1	P503	Pr Decel 5	P515
Pr Spd 2	P504	Pr Spd 6	P516
Pr Accel 2	P505	Pr Accel 6	P517
Pr Decel 2	P506	Pr Decel 6	P518
Pr Spd 3	P507	Pr Spd 7	P519
Pr Accel 3	P508	Pr Accel 7	P520
Pr Decel 3	P509	Pr Decel 7	P521
Pr Spd 4	P510		
Pr Accel 4	P511		
Pr Decel 4	P512		

Preset speed #1-7. These are speeds the drive will run at in Speed Mode when the binary preset speed inputs are set, respectively, to 1 through 7.

The following input combinations are required to achieve a given preset speed:

Terminal:	TB1-12	TB1-13	TB1-14
Input:	“BCD Speed 1”	“BCD Speed 2”	“BCD Speed 4”
Speed: Pr Spd 1	on	off	off
Pr Spd 2	off	on	off
Pr Spd 3	on	on	off
Pr Spd 4	off	off	on
Pr Spd 5	on	off	on
Pr Spd 6	off	on	on
Pr Spd 7	on	on	on

The maximum value for a preset speed is “MAX” (P201). The minimum value is “MIN” (P202). A preset speed may be changed automatically by the program if “MIN” or “MAX” is changed.

NOTE: For more on the “BCD SPEED 1, 2 and 4” inputs, see the Connection Descriptions in Chapter 3.

Pr Accel x is the acceleration time used when the drive is in Speed Mode and the binary preset speed inputs are set, respectively, to 1 through 7. This value represents the time for the drive to accelerate from minimum speed (P202) to maximum speed (P201).

Pr Decelx is the deceleration time used when the drive is in Speed Mode and the binary preset speed inputs are set, respectively, to 1 through 7. This value represents the time for the drive to decelerate from maximum speed (P201) to minimum speed (P202).

Example: At the moment of switching from Pr Spd1 to Pr Spd2, the drive selects and starts to use the acceleration time and deceleration time associated with Pr Spd2. The acceleration and deceleration times associated with Pr Spd1 are no longer used.

Skip Spd 1	P522
Skip 1 Band	P523
Skip Spd 2	P524
Skip 2 Band	P525
Skip Spd 3	P526
Skip 3 Band	P527

The motor may be set to avoid constant operation at certain speeds where an undesirable vibration or resonance occurs. Such resonance is often associated with fan loads. It may be desirable to avoid running at these speeds. These parameters are entered in engineering units, and are run locked. The drive provides three skip frequencies that can be set to avoid running at certain speeds.

“SKIP SPD 1” and “SKIP 1 BAND” sets the first skip frequency, “SKIP SPD 2” and “SKIP 2 BAND” set the second, and “SKIP SPD 3” and “SKIP 3 BAND” set the third.

Each skip frequency and band sets a skip speed range in the forward direction and reverse direction, as shown below:

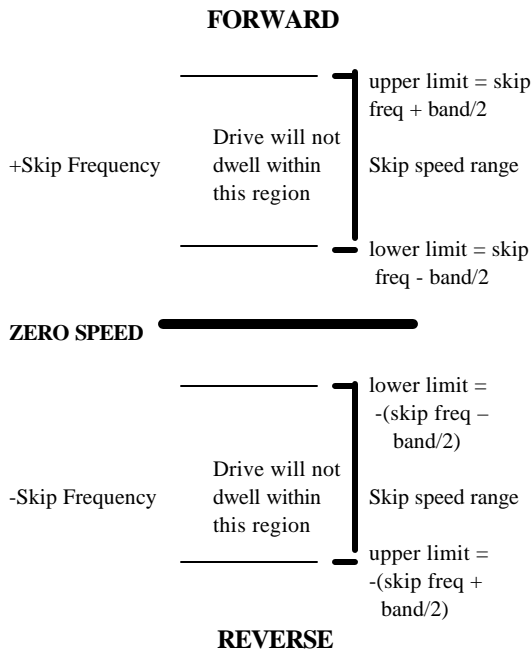

The drive will not remain at any speed within a skip speed range. The drive will accelerate to the upper limit of the range or decelerate to the lower limit.

To disable a skip frequency, set the band to 0.

Skip frequencies do not function in Slave Mode following the analog or synchronous serial speed sources.

5.4.6 - I/O Menu: 600

ILoop Minimum 601 Brief

The minimum current that the analog current input will read in (default 4mA).

ILoop Maximum 602 Brief

The maximum current that will be read in by the analog current input (default 20mA).

ILoop 603 Full

Sets the function that the analog current input will control. The selections that are available are also available to the analog voltage input. The functions available are: None, PI FBK, Jog Spd, or Spd Trim.

None - Disables the input.

PI FBK - Allows the input to be used for the feedback of a PI speed control loop. The feedback is determined from the ILoop input, and the drive command is taken from the drive command source.

Jog Spd - Sets the jog speed of the motor, where the max input is max speed of the motor and min is 0 speed of the motor. Direction is controlled via the digital direction input.

Spd Trim - This allows the user to adjust the speed of the motor around the setpoint of the motor. For the analog current it is uni-directional and will increase the setpoint speed from 0% up to the SpeedTrim (P608) value of the setpoint.

Voltage Input 604 Full

The V Input parameter controls the mode of the voltage analog input. This input can handle voltages from -10V to +10V. Setting this parameter to +10 restricts this input to unipolar values. If a negative value is received, the equivalent positive value is used. Setting this parameter to $\pm 10V$ allows the drive to follow a bipolar input.

VIn Minimum 605 Full

Adjusts the input voltage which translates into a minimum command value.

VIn Maximum 606 Full

Adjusts the input voltage which translates into a maximum command value.

VIn Function 607 Full

Sets the function that the analog voltage input will control. The functions available are the same as the Iloop parameter.

None - Disables the input.

PI FBK - Allows the input to be used for the feedback of a PI speed control loop.

Jog Spd - Sets the jog speed of the motor, where max input is max speed of the motor and min is 0 speed of the motor. Direction is controlled via the digital direction input for the unipolar case and by the polarity of the input in the bi-polar case.

SpdTrim - This allows the user to adjust the speed of the motor about the setpoint of the motor. When the analog voltage is uni-directional it will increase the setpoint speed by up to the SpeedTrim (P608) value of the setpoint. If it is bipolar the setpoint can be adjusted \pm SpeedTrim (P608) of the setpoint.

SpeedTrim 608 Full

This parameter sets the percentage change caused by the analog input when the SpdTrim is set in the VIn Fcn= parameter.

Analog Output 609 Full

Controls the function of the analog output. The available options are: IxT Acc, Mtr Spd, Set Spd, Motor I, Bus V, DB Acc, and Torq. All analog output is scaled based upon the parameters

AOut Min=, AOut Max=, and the minimum and maximum scale values.

IxT Acc - Not implemented. The output voltage is set to the minimum value.

Mtr Spd - Reflects the present speed of the motor. The maximum output value is reached when the motor speed equals the Max Speed setpoint. The minimum output is realized when the motor is stopped.

Set Spd - Scaled identically to Mtr Spd. The data used in determining the analog output is the speed command of the motor.

Motor I - Converts the motor current to an analog voltage with 150% of motor rated current as the maximum value.

Bus V - Converts the DC Bus Voltage into an analog voltage. For 230 V drives, the maximum value is equivalent to 500 V. For 460 V drives, the maximum value is 1000 V.

DB Acc - This function is unimplemented. The output voltage remains at the minimum value.

Torq - Motor torque is converted to an analog voltage when this parameter is selected. This option has a maximum value equivalent to 150% motor rated torque.

Analog Out Min 610 Full

Minimum output that the analog output will put out.

Analog Out Max 611 Full

Maximum output that the analog output will provide.

Digital Inputs 1/2/3 612/613/614 **Full**

These parameters control the functions that are assigned to the operator adjustable digital inputs. Din1, Din2, Din3 correspond to digital inputs 1, 2 and 3 respectively. The possible selections for these parameters are: Speed 1, Speed 2, Speed 3, Coast, Fault Reset, and Loc/Rem.

Speed 1, Speed 2, Speed 3 - Allows the operator to select from 1 to 7 preset speeds by using the digital inputs to select which preset speed to be used. The selection is made as follows:

Speed 3	Speed 2	Speed 1	Preset Speed
0	0	0	No Preset
0	0	1	Preset Speed 1
0	1	0	Preset Speed 2
0	1	1	Preset Speed 3
1	0	0	Preset Speed 4
1	0	1	Preset Speed 5
1	1	0	Preset Speed 6
1	1	1	Preset Speed 7

Note: If only Speed 1 is used the operator can select 1 preset speed, if speed 1 and 2 are used then up to 3 preset speeds can be selected, and if all three are used then up to seven can be selected.

C to R - If this function is chosen then the input will be used to activate the coast to rest option. When this input is a logical true, stopping the drive will cause it to coast. When the input is a logical false, the stopping mode is determined by the Stop= parameter (P406).

Fault Reset - Clears a run inhibit drive fault, and forces the motor to stop. The fault LED will quit blinking, and once this input is released (Logic False), the motor may be started.

Loc/Rem - This allows the user to select what is to be used to determine the speed reference. See table.

	Setpt Src = Keypad	Setpnt Src = Analog
Loc/Rem = Inactive (No connection to Lcom)	Reference is the keypad	Reference in the analog voltage input.
Loc/Rem = Active (Connection to Lcom)	Reference is the analog current input.	Reference is the analog current input.

Digital Output 1	615	
Digital Output 2	617	
Relay Output	619	Full

These parameters are used to set the function for each of the user selectable outputs. The selections for these parameters are: Speed, Mtr Torq, @Set Spd, Mtr Amps, Bus V, IxT Accum, DB Accum, Overload, Fault, Ready, and Run.

Speed - If Speed is selected the output will activate when the selected speed is exceeded. The output is deactivated if the selected speed drops below the setpoint. The speed is set in the Dout1, Dout2, and Relay set parameters.

Mtr Torq - When a selected motor torque is reached the output assigned to it will activate. The output is deactivated if the motor torque drops below the setpoint. The Mtr Torq is set in the Dout1, Dout2, and Relay set parameters.

@Set Spd - The output will activate if the current motor speed is within ten percent of the current motor setpoint. If the setpoint is less than 100 RPM, the speed is considered at the setpoint if it is within 10 RPM. The output is cleared if it is not within these ranges.

Motor Amps - If selected, the output will activate when the selected motor current is reached. The output is deactivated if the motor current drops below the setpoint. The motor current value is set in the Dout1, Dout2, and Relay set parameters.

Bus V - The Bus V function allows the user to select a bus voltage at which the selected output will activate. The output is deactivated if the bus voltage drops below the setpoint. The bus voltage is set in the Dout1, Dout2, and Relay set parameters.

IxT Accum - The IxT Accum function will activate an output when the IxT accumulator reaches a set level. The IxT accum level is set in the Dout1, Dout2, Relay set parameters.

DB Accum - The DB Accum function will activate an output when the DB accumulator reaches a set level. The DB accum level is set in the Dout1, Dout2, Relay set parameters.

Overload - The Overload is a percentage from 0 to 100. This number represents the percentage over 100% of current being used by the drive. The percentage is relative to motor rated current. If the motor current proceeds above (100 + setpoint) percent, this digital output will be activated. If it drops below this value, the output will be deactivated. The percentage of the overload level beyond the continuous range can be set in the Dout1, out2, Relay set parameters.

Fault - When a fault is prohibiting the system from running, the Fault output will be activated. If no faults are interfering with motor operation, the output will be deactivated.

Ready - Ready will activate an output when drive initiation is complete and all systems are found to be operating correctly.

Run - If Run is selected, the output becomes active anytime the drive is controlling the motor. This includes while the motor is ramping to a stop. If the motor is stopped, the output is deactivated

Digital Out 1 Setpoint	616	
Digital Out 2 Setpoint	618	
Relay Output Setpoint	620	Full

These parameters contain the setpoint for each function associated with an output. If a selection needs a setpoint, this menu will automatically adjust to display and allow entry of the correct value. If no setpoint is necessary, the text None will be displayed.

Speed - Adjustable setpoint in engineering units.

Mtr Torq - Adjustable setpoint in percent of full scale torque.

@Set Spd - Has as no setpoint.

Mtr Amps - Has as an adjustable setpoint in Amps.

Bus V - Adjustable setpoint in Volts.

IxT Accum - Adjustable setpoint

DB Accum - Adjustable setpoint in % of power rating used.

Overload - Adjustable setpoint in % of current over motor rated current.

Ready - Has no setpoint.

Run - Has no setpoint.

Ex: Dout1 Set = Speed
 Dout2 Set = 900

5.4.7 - Serial Param: 700

The parameters necessary to adjust the external serial port are located in this menu. Note that Parity, Data Bits, and Stop Bits are fixed to N81.

Baud Rate	701	Full
------------------	------------	-------------

Sets the communication rate of the serial port. Available options are: 19200, 9600, 2400, or 1200.

Unit ID	702	Full
----------------	------------	-------------

The ID number (address) of the drive. Selectable from 1 to 9, A-Z.

5.4.8 - Fault Status:

A fault indication is generated and the drive trips when a fault condition occurs. The available fault codes are listed below. Section 7.1 Troubleshooting Fault codes contains descriptions along with possible solutions for each fault.

- ? None
- ? Output Shorted
- ? Excessive DB
- ? Over Current
- ? Single Ph Input
- ? DC Bus Undervolt
- ? DC Bus Overvolt
- ? IGBT Base Drive
- ? A/D Offset Tol
- ? Motor Output
- ? Heatsink Temp
- ? Overload
- ? Comm Error
- ? Ext Trip
- ? EEPROM Fault
- ? Motor Par Error

The following describes the Fault displays:

Present Fault **Full**

The last fault that the drive encountered. If SCROLL/CHANGE is pressed when the fault in question is displayed, the following can be viewed:

Drive Mode - Displays the state of the drive at the time of the fault. It is a binary number with a 1 indicating set. From left to right (msb to lsb), the data indicates:

MSB							LSB
System Initializing	Drive Faulted	Request Direction Change	Commissioning	Reversing	Running	Stopping	Reverse Direction

Flt Time - The time when the fault displayed occurred.

Mtr Amps - The current applied to the motor when the fault occurred.

Mtr Spd - The speed of the motor at the time of the fault.

Bus Volts - The bus voltage when the drive fault condition happened.

Fault2 **Full**

The fault that occurred prior to the Present Fault.

Fault3 **Full**

The fault that occurred prior to Fault2.

Fault4 **Full**

The fault that occurred prior to Fault3.

5.4.9 - Parameter Table

Menu	Parameter Name	Default Value	Param. Number	Serial Code (HEX)	Min	Max	Units	Selections / Comments
SetUp	Motor Power	Drive Rating Depends on Unit	101	006	0.0	99.9	Hp	N/A
SetUp	Motor Volts	Drive Rating Depends on Unit	102	007	0	1000	Volts	N/A
SetUp	Motor Amps	Drive Rating Depends on Unit	103	008	0.1	99.9	Amps	N/A
SetUp	Motor Speed	Drive Rating Depends on Unit	104	009	500	9999	RPM	N/A
SetUp	Rated Freq	60	105	00A	30	400	Hz	N/A
SetUp	Autotune Drive	N/A	106	206	N/A	N/A	N/A	N/A
SetUp	Motor SF	1.15	107	00B	0.8	1.50	N/A	N/A
SetUp	Ext Brk Res	100	108	00C	100	20000	W	N/A
Main	Max Spd	1800	201	00D	0	9999	Note 1	N/A
Main	Min Spd	18	202	00E	0	9999	Note 1	N/A
Main	Accel Time	10.0	203	00F	0.1	999.9	Sec	N/A
Main	Decel Time	10.0	204	010	0.1	999.9	Sec	N/A
Main	Jog Speed	100	205	011	0	9999	Note 1	N/A
Main	Jog Accel	1.0	206	012	0.1	999.9	Sec	N/A
Main	Jog Decel	1.0	207	013	0.1	999.9	Sec	N/A
Main	Spd Setpt	100	208	014	0	9999	Note 1	N/A
Main	Trq Setpt	50	209	015	0	100	%	
Main	Mtr Trq Lmt	150	210	016	0	200	%	
Main	Brk Trq Lmt	150	211	017	0	200	%	
Main	Eng Scale	1800	212	018	100	9999	N/A	N/A
Main	Eng Dec Pt	0	213	019	0	3	N/A	N/A
Main	Eng Char 1	R	214	01A	0	2		Note 2

Menu	Parameter Name	Default Value	Param. Number	Serial Code (HEX)	Min	Max	Units	Selections / Comments
Main	Eng Char 2	P	215	01B	0	2		Note 2
Main	Eng Char 3	M	216	01C	0	2		Note 2
Main	Top Disp	Speed	217	01D	Speed	Freq	N/A	Speed, Torque, Current, Vbus, Freq
Main	Bot Disp	Torque	218	01E	Speed	Freq	N/A	Speed, Torque, Current, Vbus, Freq
Main	Menu	Brief	219	01F	Full	Brief	N/A	Full - All Menus Brief - Some Menus
Main	Default Factory	Exit	220	N/A	Exit	Recall	N/A	Exit - Exit default factory. Recall - Set drive to set values.
Main	Default User	Exit	221	N/A	Exit	Save	N/A	Exit - Exit default user. Recall - Set drive to set values. Save - Save values
Status*	SpdSet	100	301		0	9999	Note 1	Read Only
Status*	Speed	N/A	302	304	0	9999	Note 1	Read Only
Status*	Trq Set	50	303		0	100	%	Read Only
Status*	Torque	N/A	304	306	0	999	%	Read Only
Status*	Mtr Amps	N/A	305	300	0	99.9	Amps	Read Only
Status*	Mtr Freq	N/A	306	303	0	400	Hz	Read Only
Status*	Mtr Volts	N/A	307	301	0	1000	Volts	Read Only
Status*	Bus Volts	N/A	308	302	0	1000	Volts	Read Only
Status*	IxT Accum	N/A	309		0	100	%	Read Only
Status*	DB Accum	N/A	310		0	100	%	Read Only
Status*	Pwr In	N/A	311		0	99.99	Kw	Read Only
Status*	Pwr Out	N/A	312	307	0	99.99	Kw	Read Only
Status*	Enrgy	N/A	313		0	65536	KWH	Read Only
Status*	Hrs Run	N/A	314		0	65536	Hr	Read Only
Status*	HS Temp	N/A	315		0	99.9	C	Read Only
Status*	In Stat	N/A	316		N/A	N/A	N/A	Read Only
Status*	Out Stat	N/A	317		N/A	N/A	N/A	Read Only
Status*	Drv Size	N/A	318	0E4	N/A	N/A	Hp	Read Only Hp - 230 /460

Menu	Parameter Name	Default Value	Param. Number	Serial Code (HEX)	Min	Max	Units	Selections / Comments
Status*	Ver	N/A	319	-	N/A	N/A	N/A	Read Only Version Number
Status*	Serial #	N/A	320	13D	N/A	N/A	N/A	Read Only Serial Number
Status*	Enable Scroll	N	321	020	N	Y	N/A	Y - Yes N - No
OpMode	Setpt Src	Keypad	401	021	Keypad	Analog	N/A	Keypad - Setpoint Operation is done via the keypad Analog - Setpoints are made via an analog input.
OpMode	Cmd Src	Keypad	402	022	Keypad	Terminal	N/A	Keypad, Serial, Terminal
OpMode	Start	Manual	403	024	Manual	Line	N/A	Manual - Run command must be given Line - starts after power up
OpMode	Run	Speed	404	025	Speed	Torque	N/A	Speed - Speed mode Torque - Torque Mode
OpMode	Jog	Jog Speed	405	02	Jog Speed	Run Speed		Jog - Uses jog speed parameter for jog rate Run - Uses set speed for jog rate
OpMode	Stop	Ramp	406	026	Ramp	DC Hold	N/A	Ramp - Stops using decel value Coast - Coast to Rest DC Hold - DC current applied at stop for period of time.
OpMode	Fwd / Rev	Fwd	407	027	Fwd	Jog	N/A	Fwd - Forward Only. Always - Can change direction at any time. Stopped - Change direction after a stop. Jog - Can only reverse in jog mode.
OpMode	Security	00000	408	001	00000	ZZZZZ	N/A	Can set a security password consisting of numbers and letters.
OpMode	Pgain	0.0	409	028	0.0	10.0	N/A	
OpMode	Igain	0.00	410	029	0.00	1.00	N/A	
OpMode	S-Ramp	Disable	411	02A	Enable	Disable	N/A	Enable, Disable
OpMode	Eff. Opt	Disable	412	02B	Enable	Disable	N/A	Enable, Disable
OpMode	Inertia	20	413	02C	0	100	%	
OpMode	Catch Spin Mtr	N	414	02D	No	Yes	N/A	NOT PRESENTLY AVAILABLE
OpMode	Hld Brake I	100	415	02E	000	100	%	
OpMode	Hld Brake T	1.0	416	02F	0	99	Sec	
OpMode	Trip Restarts	0	417	030	0	99		
OpMode	Restart Time	5	418	031	0	99	Sec	

Menu	Parameter Name	Default Value	Param. Number	Serial Code (HEX)	Min	Max	Units	Selections / Comments
------	----------------	---------------	---------------	-------------------	-----	-----	-------	-----------------------

Preset	Pr Spd 1	100	501	032	0	9999	Note1	Preset Speed 1
Preset	Pr Accel 1	3.0	502	033	0.1	999.9	Sec	Preset 1 Accel
Preset	Pr Decel 1	3.0	503	034	0.1	999.9	Sec	Preset 1 Decel
Preset	Pr Spd 2	100	504	035	0	9999	Note1	Preset Speed 2
Preset	Pr Accel 2	3.0	505	036	0.1	999.9	Sec	Preset 2 Accel
Preset	Pr Decel 2	3.0	506	037	0.1	999.9	Sec	Preset 2 Decel
Preset	Pr Spd 3	100	507	038	0	9999	Note1	Preset Speed 3
Preset	Pr Accel 3	3.0	508	039	0.1	999.9	Sec	Preset 3 Accel
Preset	Pr Decel 3	3.0	509	03A	0.1	999.9	Sec	Preset 3 Decel
Preset	Pr Spd 4	100	510	03B	0	9999	Note1	Preset Speed 4
Preset	Pr Accel 4	3.0	511	03C	0.1	999.9	Sec	Preset 4 Accel
Preset	Pr Decel 4	3.0	512	03D	0.1	999.9	Sec	Preset 4 Decel
Preset	Pr Spd 5	100	513	03E	0	9999	Note1	Preset Speed 5
Preset	Pr Accel 5	3.0	514	03F	0.1	999.9	Sec	Preset 5 Accel
Preset	Pr Decel 5	3.0	515	040	0.1	999.9	Sec	Preset 5 Decel
Preset	Pr Spd 6	100	516	041	0	9999	Note1	Preset Speed 6
Preset	Pr Accel 6	3.0	517	042	0.1	999.9	Sec	Preset 6 Accel
Preset	Pr Decel 6	3.0	518	043	0.1	999.9	Sec	Preset 6 Decel
Preset	Pr Spd 7	100	519	044	0	9999	Note1	Preset Speed 7
Preset	Pr Accel 7	3.0	520	045	0.1	999.9	Sec	Preset 7 Accel
Preset	Pr Decel 7	3.0	521	046	0.1	999.9	Sec	Preset 7 Decel
Preset	Skip Spd 1	0	522	047	0	9999	Note1	Skip Speed 1
Preset	Skip Band 1	0	523	048	0	1800	Note 1	Skip Band 1
Preset	Skip Spd 2	0	524	049	0	9999	Note1	Skip Speed 2
Preset	Skip Band 2	0	525	04A	0	1800	Note 1	Skip Band 2

Menu	Parameter Name	Default Value	Param. Number	Serial Code (HEX)	Min	Max	Units	Selections / Comments
Preset	Skip Spd 3	0	526	04B	0	9999	Note1	Skip Speed 3
Preset	Skip Band 3	0	527	04C	0	1800	Note 1	Skip Band 3
I/O	Iloop Min	4	601	04D	0	20	mA	
I/O	Iloop Max	20	602	04E	0	20	mA	
I/O	Iloop	None	603	04F	None	SpdTrim	N/A	None - No function PI Fbk - Feedback for PI Loop Ext. Jog Spd - Jog speed reference Spd Trim - Speed trim reference.
I/O	VInput	+10	604	050	+10	+/-10	V	0 to +10 V ref. -10 to +10V ref.
I/O	Vin Min	0	605	051	0	10	Volts	
I/O	Vin Max	+10	606	052	0	+10	Volts	
I/O	Vin Fcn	None	607	053	None	SpdTrim	N/A	Same a Iloop
I/O	Spd Trim	20	608	054	10	90	%	
I/O	AOut	Mtr Spd	609	055	Set Spd	Mtr Spd	Note 3	Set Spd, Motor I, Bus V, DB Acc, Torq, IxT Acc, Mtr Spd,
I/O	AOut Min	0	610	056	0	10	V	
I/O	AOut Max	+10	611	057	0	+10	V	
I/O	Din1	Speed 1	612	058	Fault Reset	C to R	N/A	Speed 1, Speed 2, Speed 3, C to R, Fault Reset, Loc/R em
I/O	Din2	Loc/Rem	613	059	Fault Reset	C to R	N/A	Same as Din1.
I/O	Din3	Fault Reset	614	05A	Fault Reset	C to R	N/A	Same as Din1.
I/O	Dout1	Ready	615	05B	Ready	Fault	N/A	Speed, Mtr Torq, @ Set Spd, MtrAmps, Bus V, IxT Accum, DB Accum, Overload , Fault, Ready, Run
I/O	Dout1 Set	None	616	Note 4	Note3	Note 3	Note 3	
I/O	Dout2	@Set Spd	617	05C	Fault Reset	Fault	N/A	Same as Dout1
I/O	Dout2 Set	None	618	Note 4	Note3	Note 3	Note 3	
I/O	Relay	Fault	619	05D	Fault Reset	Fault	N/A	Same as Dout1

Menu	Parameter Name	Default Value	Param. Number	Serial Code (HEX)	Min	Max	Units	Selections / Comments
I/O	Relay Set	None	620	Note 4	Note 3	Note 3	Note 3	

Serial Params	Baud Rate	9600	701	05E	1200	19200	bps	1200, 2400,4800, 9600, 19200
Serial Params	Unit ID	1	702	05F	1	Z	N/A	
Fault Status	Present Fault	None	N/A		N/A	N/A	N/A	Flt time, Mtr Amps, Mtr Spd, Bus Volts
Fault Status	Fault2	None	N/A		N/A	N/A	N/A	Flt time, Mtr Amps, Mtr Spd, Bus Volts
Fault Status	Fault3	None	N/A		N/A	N/A	N/A	Flt time, Mtr Amps, Mtr Spd, Bus Volts
Fault Status	Fault4	None	N/A		N/A	N/A	N/A	Flt time, Mtr Amps, Mtr Spd, Bus Volts

Note 1: Displayed values and labels are dependent on the engineering scale, engineering decimal point and the engineering characters that have been selected.

Note 2: The characters that can be displayed are the printable set of ASCII characters.

Note 3: The function that is selected will determine the ranges and units that will be displayed.

Note 4: Depending on the selection the serial parameter varies as follows:

		<u>Serial Code</u>	<u>Default</u>	<u>Min</u>	<u>Max</u>
Out1 Set =	Speed	060	1800	0	9999
	Torque	061	100	0	100
	Amps	062	90%	0	200%
	Bus	063	70% of Max.	0	0
	Ixt	064	95%	0	100
	DB	065	80%	0	100
	Overload	066	100%		
Out2 Set =	Speed	067	1800	0	9999
	Torque	068	100	0	100
	Amps	069	90%	0	200%
	Bus	06A	70% of Max.	0	0
	Ixt	06B	95%	0	100
	DB	06C	80%	0	100
	Overload	06D	100	0	100
Relay Set =	Speed	06E	1800	0	9999
	Torque	06F	100	0	100
	Amps	070	90%	0	200%
	Bus	071	70% of Max.	0	0
	Ixt	072	95%	0	100

DB	073	80%	0	100
Overload	074	100	100	100

6.0 - Serial Communications

This section describes the serial communication capabilities of the SC4000 including the following:

- ? Connection of an external computer to monitor and control the SC4000.
- ? Describe how to establish a network of SC4000 drives.
- ? How to communicate with the SC4000 drive including communication protocol.

Overview

An external computer can be used to remotely setup, monitor, and control the operation of the SC4000 by connecting them serially. As many as 32 drives can be linked together in a network, allowing coordination of integrated systems by a host computer. Standard EIA RS-485 serial connections (up to 10 drives) allows reliable communication over relatively long distances. The communication protocol is industry standard, "ANSI-x3.28-2.5-A4."

RS-485 Connections

The SC4000 has one RS-485 serial connection that utilizes a standard RJ-11 phone connector. The RS-485 differential connections provide greater noise immunity than single-ended RS-232 connections. You can connect an RS-232 device using an RS-485-to-RS-232 adapter such as B&B Electronics part number 485SD9TB.

RS-485 Serial Port Specifications

The RS-485 Specifications are shown below.

Baud Rate	1200 - 19200
Data Length	8 Bits
Stop Bits	1 bit
Parity	one
Method	Half Duplex

The RJ11 connections are shown on the table below. When daisy chaining drives only pins 2,3 and 4 should be used. A standard RJ11 tee can be used for daisy chaining drives. The cable length between the tee and the drive should be minimized. However, up to 300m of twisted pair cable can be used. The power ground / return connection should not be made via the RJ11 connector. A separate return cable is required.

The unit at the end of a chain of drives must have a termination resistor (100 ohms) installed in the jumper 7 (J7) position.

Pin	Name	Description
1	+12V	+12V Auxiliary Power
2	COM	Power Common
3	A	RS-485 Signal
4	B	RS-485 Signal
5	SCOM	Signal Common
6	NC	No Connection

6.1 - Communication Protocol

The host acts as the master and initiates the transmissions. The protocol has two basic commands, read or write. The read command allows the host to read the value of *any* parameter. The write command allows the host to write to a parameter that is *write accessible*.

The typical transmission sequence to the drive is as follows:

1. The host transmits a command to the drive, which includes the drive addressing.
2. The host should receive a response within 400mS. If it does not receive a response the host should resend the command. If this is tried for ten (10) times and no response is received, the host should indicate a transmission error.
3. The drive that is addressed in the command sends a response to the host.
4. After a proper reply was received, the host should wait approximately 1mS before sending another message.

6.1.1 - Issuing a Read Command

The read command consists of 6 characters a dollar sign, read character, a one character address, a three character parameter number, in hex, and a checksum character. The address can be 1-9, A-Z. The parameters with their hex address are shown on the table on page XX. The checksum is a calculated value and will be discussed later. The format of the transmission is shown below.

Read	Add	Param Char 1	Param Char 2	Param Char 2	Checksum	Carriage Return
\$	W	X	X	X	C	<CR>

Note, the SC4000 uses a half-duplex method to implement serial communications. This means that one twisted pair of wires is used for transmit and receive. A host (computer, PLC, etc.) is required to originate all communications. When a drive detects a communication which includes its assigned address the drive responds with an acknowledgement that the message was received and the instructions carried out or with an error message to indicate the message was not received correctly. If the host needs to monitor some drive data the host must poll the drive asking for the data. The drive will send the information requested.

The % character denotes a response to a query, W is once again the address of the drive, XXX is the parameter in hex, YYYY is the data in hex and C is the checksum.

Response	Address	Param Char1	Param Char2	Param Char3	Data Char1	Data Char2	Data Char3	Data Char4	Checksum	Carriage Return
%	W	X	X	X	Y	Y	Y	Y	C	<CR>

See Section 6.3.1 for an example of the Checksum calculation and Read command usage.

6.1.2 - Issuing a Write Command

The write command can be used to send data to the drive. The host can only send data to a parameter that is write accessible. If the parameter is not write accessible, the drive will respond with an error. The write command has the similar format to that of the **response** from a read command, but the first character is a &. The format for the data string is: &WXXXXYYCYC<CR>.

Response	Address	Param Char1	Param Char2	Param Char3	Data Char1	Data Char2	Data Char3	Data Char4	Checksum	Carriage Return
&	W	X	X	X	Y	Y	Y	Y	C	<CR>

If the checksum and the command are valid, the drive will write the data to the parameter indicated and the respond back to the host that it has completed the command. The response that is sent is: #XC<CR>.

Where: # is the acknowledgement (ACK) character

X is the address of the drive

C is the checksum

ACK character	Address	Checksum
#	X	C

See Section 6.3.2 for an example of the Checksum calculation and use of the Write command.

6.2 - Drive Transmitted Serial Errors

If the keypad receives a command that is addressed to it and it does not understand the command or the checksum is incorrect the drive will respond with: ?XYC<CR>

Error character	Address	Error Code	Checksum
?	X	Y	C

The error codes are defined below.

Error Code	Description
1	Bad Checksum
2	Bad Hex Character
3	Attempt to write to a read-only location
4	Input buffer overrun
5	Command not defined
6	Attempt to write to a run locked parameter while drive is running.
7	Address is out of range.

E.g.) If a checksum is calculated incorrectly and addressed for drive 1, the drive will respond with: ?11a

Error character	Address	Error Code	Checksum
?	1	1	a

6.3 - Communication Error Detection

The communication protocol includes a method of detecting errors in the transmission of information. These errors may be caused by electrical interference corrupting the data. The method of detecting these errors is using a checksum. A checksum of all the information to be transmitted is calculated by the host and added to the last character sent before the end of transmission (carriage Return character). The drive receives the transmitted information and calculates a checksum then compares it to the checksum transmitted by the host. If the two agree the data is accepted as good. If they are not the same the drive transmits an error message which should cause the host to retransmit the data.

6.3.1 - Checksum Calculation for Read Command

The checksum is calculated as follows:

1. Add all of the hex values of the ASCII characters that are to be sent together. Do not include the checksum byte or the carriage return.

E.g.) \$1006 is to be sent to query the motor horsepower.

ASCII Character	Hex Value of the ASCII Character
\$	24
1	31
0	30
0	30
6	36
Sum in Hex	EB

2. Take the sum and **AND** it with 7Fh. This will limit the number to the first 128 ASCII characters.
E.g.)

Hex Value	Binary Equivalent
EB	11101011
7F	01111111
EB AND ed? 7F	
Result = 6B	01101011

3. Now, Take the above result and **OR** it with 40h. This will shift the characters by 40 hex characters. I.E. shift the result to the printable characters.

Hex Value	Binary Equivalent
6B	11101011
40	01000000
6B OR ed? 40	
Result = 6B Hex or 107 Decimal	11101011

4. Now look on an ASCII table to determine the character that is to be used as the checksum. In this case it is a lower case **k**?
5. Therefore the transmitted string is as follows: \$1006k<CR>.

If the command and the checksum is valid the drive will respond with information in the following format: %WXXXYYCYC<CR>

If the checksum or the command is not valid the drive will respond with an error.

Using the above example the drive would have responded with: %1006001EB

Response	Address	Param Char1	Param Char2	Param Char3	Data Char1	Data Char2	Data Char3	Data Char4	Checksum	Carriage Return
%	1	0	0	6	0	0	1	E	B	<CR>

This would give the data as a hex 1E or decimal 30. For motor horsepower we divide by 10 to determine what the drive setting for the motor horsepower is, in this case 3.0 Hp.

6.3.2 - Checksum Calculation for Write Command

The checksum is calculated like the read command, but now the data characters must be included in the summing of the hex values.

An example of this is to send a serial start command to the drive. In this case the string that would have to be sent down is: &12000001C<CR>

1. Add the hex values of the ASCII characters not including the checksum byte or the carriage return.

ASCII Character	Hex Value of the ASCII Character
&	26
1	31
2	32
0	30
0	30
0	30
0	30
0	30

1	31
Sum of Hex Values	1AA (110101010)

(Binary)

2. Now ? **AND**? the sum of the hex values with 7Fh.

Hex Value	Binary Equivalent
1AA	110101010
7F	001111111
1AA ? AND ? 7F	
Result = 2A	00101010

3. Next, ? **OR**? the result, in this case 2Ah, with 40h.

Hex Value	Binary Equivalent
2A	00101010
40	01000000
2A ? OR ? 40	
Result = 6A Hex or 106 Decimal	01101010

4. If decimal 106 is looked up on an ASCII table, this would correspond to a lower case ?j?. This would then be used as the checksum character at the end of the transmitted string.
5. Therefore the string that would need to be sent is: &12000001j<CR>

From our above example, the acknowledgement would be: #1T

7.0 - Troubleshooting



Dangerous high voltages exist in this product. Be certain the power has been removed for a minimum of 5 minutes before any service work or circuit board configuration changes are performed.

Before any troubleshooting operations are performed re-read Section 2 – Cautions and Warnings.

7.1 – Troubleshooting Fault Codes

When a fault condition occurs due to a protective circuit trip the fault indication LED will illuminate and the drive will trip. The reason for the fault will be displayed on line 2 of the LCD display. This section provides a description of the available fault indicators, probable causes of the displayed fault, and some possible solutions. If a fault persists contact the Applications Engineering department, Technical Support for assistance at 1-800-787-3532.

Note that the drive retains the last four faults in memory. These can be accessed through the Fault menu. For each fault the time the fault occurred, motor current, motor speed, bus voltage, and drive mode can be viewed. See Section 5.4.8 Fault Status for a description of each.

None

There are no known faults present.

Output Shorted

A short phase to phase or phase to ground has been detected. It could be in the drive, motor, or DB braking circuit.

Excessive DB

Regenerative energy has exceeded the capabilities of the drive. Increase deceleration time to correct this fault or install optional DB resistors.

Over Current

This fault is most likely the result of excessive starting torque or high peak torque transients. The drive is capable of operating at 150% of rated current for 60 seconds and 200% for approximately 3 seconds maximum.

If motor torque limit in the main menu is set above 150% the fault may be resolved by setting it to 150 or lower. This will reduce starting torque. Sudden large increases in load can also cause this fault. Increasing the inertia parameter in the OpMode menu (413) will allow the motor speed to decrease during sudden load increases.

If the fault occurs during rapid acceleration or deceleration it may be necessary to increase the respective accel or decel time. In addition, if an attempt is made to start a spinning motor while the Catch Spin Motor parameter (414) is set to No could also cause this fault.

Single Ph Input

This fault indicates that the AC input power to the drive is a single-phase input and the drive is operating at above the allowed power level (230 V units only). See Input Line Considerations in Section 4.0 for power level de-rating information. If a three-phase input is required verify the input line looking for a blown fuse, faulty circuit breaker, or loose/corroded connections.

DC Bus Undervolt

The DC bus voltage in the drive has dropped too Low for proper operation. The AC input voltage being below its low limit usually causes this. Verify the AC input voltage is correct, 200-240 VAC for SC42xx units and 380-480 VAC for SC44xx units. If the fault occurs frequently there may be temporary low voltage conditions caused by starting large motors or other equipment. If this is the case contact Technical Support for assistance in selecting a line reactor or isolation transformer. If the fault occurs upon start-up the drive may be defective. Contact Technical Support for assistance.

DC Bus Overvolt

The DC bus voltage in the drive is too High for safe operation. This fault could be caused by too rapid of a deceleration rate or the AC input line being above its allowable limit. If the fault occurs during stopping or deceleration the likely cause is excessive load inertia. The drive will try to compensate for this by increasing the deceleration time, however during very fast decelerations the drive may not have enough time to respond. Increase the deceleration time or if rapid deceleration is required install optional dynamic braking resistors.

If the fault can not be attributed to deceleration, verify the AC input voltage is correct, 200-240 VAC for SC42xx units and 380-480 VAC for SC44xx units. Another source of excessive voltage could be transient voltage spikes. These can be caused by other equipment in the area being switched on or off. If this is the case install input AC line conditioners such as Warner Electric's Stabiline line of products.

IGBT Base Drive

The drives internal power supply is not functioning properly. Contact Technical Support for assistance with this fault.

A/D Offset Tol

This fault indicates an internal problem with the automatic calibration of analog circuits. When this fault occurs remove power and wait several minutes then reconnect the AC power line. If this is not successful contact Technical Support for assistance.

Motor Output

This fault occurs when there is an excessive load on the motor or motor leads open. Disconnect power from the drive and wait several minutes for the internal power supplies to fully discharge. Once this is done verify the motor power wiring is intact and connected correctly. If an excessive load caused the fault, try increasing your acceleration time.

Heatsink Temp

This fault indicates that the heatsink temperature has exceeded its maximum allowable temperature of 92 °C. Check the heatsink temperature using the status menu, HS Temp parameter #315. If the temperature is above 50 °C verify the heatsink cooling fan is operating. The fan should turn on at approximately 50 °C and turn off at approximately 40 °C.

If the fan is working properly, verify that there are no obstructions to the airflow including lint and dust on the air intake or heatsink fins and the ambient temperature is within the allowable limits. If the fan is not operating, when it should as defined above, try to turn the fan manually. If the fan will not rotate, or is difficult to turn, contact Warner Electric for assistance.

Overload

The set $\overset{\circ}{F}$ T service factor has been exceeded. The motor/drive are being overloaded. Contact Technical Support for assistance in determining the motor/drive load limits for your system.

Comm Error

This fault indicates that a communication problem exists between the drive and the host. Verify connections at the host and drive. If you are unable to resolve the problem, contact Technical Support.

Ext Trip

The external trip circuit is active or not connected. Verify if there is indeed an external trip circuit active and clear it. Also, if an external trip circuit is disconnected this fault will be activated.

EEPROM Fault

The EEPROM in the drive section has failed. If this fault occurs remove power from the drive and wait several minutes to ensure all internal power supplies have completely discharged. Reapply power to the drive. If the fault's still present, contact the factory for assistance. If the error is cleared but reappears later check for transient electrical noise sources and install suppression devices such as the Warner Electric Stabiline line of surge/noise suppression equipment.

Motor Par Error

This fault occurs when inconsistent motor data has been entered in the motor setup menu (100) and autotune has been selected. Verify that the motor nameplate data has been entered and correct as necessary then select autotune. If the fault continues contact Technical Support.

APPENDIX A - SC4000 GENERAL SPECIFICATIONS

Service Conditions

AC Line Input Voltage:

Three Phase: 200 to 240VAC +/-10%, 1 - 10 HP

Single Phase: 200 to 240VAC +/-10%, 1 - 2 HP

Three Phase: 380 to 480VAC +/-10%, 1 –20 HP

Single Phase 380 to 480VAC +/-10%, 1 – 2 HP

AC Line Input Frequency: 47-66 Hz

Ambient Temperature:

Enclosed Models: 0? C to 40? C

Storage Temperature: -20? C to 70? C

Humidity: 10 to 95%, non-condensing

Altitude: 3,300 ft. without derating
2% derating for every 1,000 ft. above 3,300 ft.

Operating Conditions

Output Voltage: 0 to Input Voltage

Output Frequency: 0 to 400 Hz

Overload Capacity: 150% for 1 minute
200% for 3 seconds

Efficiency: greater than 97%, 5-20 HP drives
(with motor at rated speed greater than 95%, 1-3 HP drives
and load)

Motor Requirements

Type: AC Induction Motor, NEMA design B
2, 4, 6, 8, 10 poles
200 - 230VAC, 380 - 460VAC

Performance

Constant torque speed range: 100:1 of motor rated base speed

Speed regulation: 0.5% of motor's rated base speed, with a 95% load change

Speed reference resolution:

Analog reference input: less than 0.5% of motor's base speed

Digital reference input: 1 RPM increments

Starting torque: Adjustable 0 to 200% of motor's rated full load torque

Power loss ride through: 2 sec. minimum, unloaded motor, @ rated speed

Dynamic Braking: Internal dynamic braking electronics, optional external dynamic braking resistor kit required

Terminal I/O

Analog Voltage Input: 0 to +/- 10VDC, 8 bit
Local V_{in} Selectable by Local source
Programmable functions: Speed /Torque command
PI loop feedback
Jog Speed
Speed Trim

Analog Current Input: 0 to 20 mADC, 8 bit
Remote I_{in} Scaleable zero & span
Selectable by Remote source
Programmable functions: Speed /Torque command
PI loop feedback
Jog Speed
Speed Trim

Analog voltage reference supply: 10VDC, 10ma. Maximum

Analog Output: 0 -10VDC , 8 bit , 10ma. max.
Scalable zero & span

A_{out}
Programmable functions: I^2T Accumulator
Motor Speed
Set Speed
Motor Amps
Bus Voltage
DB Accumulator
Motor Torque

Five Digital Inputs: Ext. Trip
(active low) Stop
Run
Jog Mode
Reverse

Three Programmable Digital Inputs:

$D_{in1}, D_{in2}, D_{in3}$
Programmable functions: Preset Speed 1,2,3
(active low) Coast to Rest
Remote / Local
Fault Reset

Three Digital Outputs:

- D_{out} 1, Open Collector, rated 30 VDC, 25 mA maximum
- D_{out} 2, Open Collector, rated 30 VDC, 25 mA maximum
- D_{out} 3, Relay Form C, rated 120VAC, 0.5A, resistive, maximum

Programmable functions:

- Speed > set point
- Motor Torque > set point
- At Speed
- Motor Amps > set point
- I²T Accumulator > set point
- DB Accumulator > set point
- Overload > set point
- Fault
- Ready
- Run

Serial port communications:

- RS485, isolated
- Half Duplex
- Addressable to 35 Drives
- Optional, external line powered, RS485 to RS232 converter module available, Optional Windows based communications software

Control Modes

(Available from terminal, keypad,
or serial communications)

Stopping function:

- Ramp
- Coast
- Ramp to zero & DC Hold

Starting function:

- Manual
- Line

Drive operation:

- Jog
- Speed
- Speed PI Loop

Operating Status Information:

- Speed and Speed set point
- Torque and torque set point
- Motor Amps
- Motor Frequency
- Motor Volts
- Bus Volts
- I²T Accumulator
- DB Accumulator
- Drive Power Input

	Drive Power Output
	Energy Used
	Terminal Input Status
	Terminal Output Status
	Heat sink Temperature
	Hours Run
	Drive Size
	Software Version
	Serial Number
Fault Status:	Present Fault
	Fault 2
	Fault 3
	Fault 4
Present Fault Mode:	Fault Time
	Motor Amps
	Motor Speed
	Bus Volts
Present Drive Mode:	System Initializing
	Drive Faulted
	Request Direction Change
	Commissioning
	Reversing
	Drive Running
	Drive Stopping
	Reverse Direction
Fault Diagnostics:	Output Shorted
	Excessive DB
	A/D Offset Tolerance
	Motor Output
	Heat sink Temperature
	Overload
	Communication Error
	External Trip
	EEPROM Fault
	Motor Parameter Error

NOTES

WARRANTY AND LIMITATION OF LIABILITY

Warner Electric (the "Company"), Bristol, Connecticut, warrants to the first end user purchaser (the "purchaser") of equipment manufactured by the Company that such equipment, if new, unused and in original unopened cartons at the time of purchase, will be free from defects in material and workmanship under normal use and service for a period of one year from date of shipment from the Company's factory or a warehouse of the Company in the event that the equipment is purchased from the Company or for a period of one year from the date of shipment from the business establishment of an authorized distributor of the Company in the event that the equipment is purchased from an authorized distributor.

THE COMPANY'S OBLIGATION UNDER THIS WARRANTY SHALL BE STRICTLY AND EXCLUSIVELY LIMITED TO REPAIRING OR REPLACING, AT THE FACTORY OR A SERVICE CENTER OF THE COMPANY, ANY SUCH EQUIPMENT OF PARTS THEREOF WHICH AN AUTHORIZED REPRESENTATIVE OF THE COMPANY FINDS TO BE DEFECTIVE IN MATERIAL OR WORKMANSHIP UNDER NORMAL USE AND SERVICE WITHIN SUCH PERIOD OF ONE YEAR. THE COMPANY RESERVES THE RIGHT TO SATISFY SUCH OBLIGATION IN FULL BY REFUNDING THE FULL PURCHASE PRICE OF ANY SUCH DEFECTIVE EQUIPMENT. This warranty does not apply to any equipment which has been tampered with or altered in any way, which has been improperly installed or which has been subject to misuse, neglect or accident.

THE FOREGOING WARRANTY IS IN LIEU OF ANY OTHER WARRANTIES, EXPRESS OR IMPLIED, INCLUDING, WITHOUT LIMITATION, ANY IMPLIED WARRANTY OF MERCHANTABILITY OR FITNESS FOR A PARTICULAR PURPOSE, and of any other obligations or liabilities on the part of the Company; and no person is authorized to assume for the Company any other liability with respect to equipment manufactured by the Company. The Company shall have no liability with respect to equipment not of its manufacture. **THE COMPANY SHALL HAVE NO LIABILITY WHATSOEVER IN ANY EVENT FOR PAYMENT OF ANY INCIDENTAL OR CONSEQUENTIAL DAMAGES, INCLUDING, WITHOUT LIMITATION, DAMAGES FOR INJURY TO ANY PERSON OR PROPERTY.**

Written authorization to return any equipment or parts thereof must be obtained from the Company. The Company shall not be responsible for any transportation charges.

IF FOR ANY REASON ANY OF THE FOREGOING PROVISIONS SHALL BE INEFFECTIVE, THE COMPANY'S LIABILITY FOR DAMAGES ARISING OUT OF ITS MANUFACTURE OR SALE OF EQUIPMENT, OR USE THEREOF, WHETHER SUCH LIABILITY IS BASED ON WARRANTY, CONTRACT, NEGLIGENCE, STRICT LIABILITY IN TORT OR OTHERWISE, SHALL NOT IN ANY EVENT EXCEED THE FULL PURCHASE PRICE OF SUCH EQUIPMENT.

Any action against the Company based upon any liability or obligation arising hereunder or under any law applicable to the sale of equipment, or the use thereof, must be commenced within one year after the cause of such action arises.

The right to make engineering refinements on all products is reserved. Dimensions and other details are subject to change.

Distribution Coast-To-Coast and International

Warner Electric motion control products are available worldwide through an extensive authorized distributor network. These distributors offer literature, technical assistance and a wide range of models off the shelf for fastest possible delivery and service. In addition, Warner Electric sales engineers are conveniently located to provide prompt attention to customers' needs. Call the nearest office listed for ordering and application information or for the address of the closest authorized distributor.

In U.S.A. and Canada

383 Middle Street
Bristol, CT 06010
Tel: 860-585-4500
Fax: 860-589-2136
Customer Service: 1-800-787-3532
Product Application: 1-800-787-3532
Product Literature Request: 1-800-787-3532
Fax: 1-800-766-6366
Web Site: www.warnernet.com

In Europe

Warner Electric (Int.) Inc.
La Pierreire
CH-1029 Villars-Ste-Croix, Switzerland
Tel: 41 021 631 33 55
Fax: 41 021 636 07 04



383 MIDDLE STREET • BRISTOL, CT 06010
(860)585-4500 • FAX: (860) 589-2136

People Finding A Better Way™

