



---

**MOTION TECHNOLOGY DIVISION**

110 Fordham Road  
Wilmington, MA 01887  
(978) 988-9800  
Fax (978) 988-9940

Part# MA940  
List Price \$30 U.S.  
August, 1998  
Rev D

**M A 9 4 0**

**OC940 Hardware & Software Reference Manual**

**For use with Firmware version 3.x**

---

This document is copyrighted by Pacific Scientific Company. It is supplied to the user with the understanding that it will not be reproduced, duplicated, or disclosed in whole or in part without the express written permission of Pacific Scientific Company.

---

## **WARRANTY AND LIMITATION OF LIABILITY**

### **Includes software provided by Pacific Scientific**

Pacific Scientific warrants its motors and controllers (“Product(s)”) to the original purchaser (the “Customer”), and in the case of original equipment manufacturers or distributors, to their original consumer (the “Customer”) to be free from defects in material and workmanship and to be made in accordance with Customer’s specifications which have been accepted in writing by Pacific Scientific. In no event, however, shall Pacific Scientific be liable or have any responsibility under such warranty if the Products have been improperly stored, installed, used or maintained, or if customer has permitted any unauthorized modifications, adjustments, and/or repairs to such Products. Pacific Scientific’s obligation hereunder is limited solely to repairing or replacing (at its option), at its factory any Products, or parts thereof, which prove to Pacific Scientific’s satisfaction to be defective as a result of defective materials or workmanship, in accordance with Pacific Scientific’s stated warranty, provided, however, that written notice of claimed defects shall have been given to Pacific Scientific within two (2) years after the date of the product date code that is affixed to the product, and within thirty (30) days from the date any such defect is first discovered. The products or parts claimed to be defective must be returned to Pacific Scientific, transportation prepaid by Customer, with written specifications of the claimed defect. Evidence acceptable to Pacific Scientific must be furnished that the claimed defects were not caused by misuse, abuse, or neglect by anyone other than Pacific Scientific.

Pacific Scientific also warrants that each of the Pacific Scientific Motion Control Software Programs (“Program(s)”) will, when delivered, conform to the specifications therefore set forth in Pacific Scientific’s specifications manual. Customer, however, acknowledges that these Programs are of such complexity and that the Programs are used in such diverse equipment and operating environments that defects unknown to Pacific Scientific may be discovered only after the Programs have been used by Customer. Customer agrees that as Pacific Scientific’s sole liability, and as Customer’s sole remedy, Pacific Scientific will correct documented failures of the Programs to conform to Pacific Scientific’s specifications manual. PACIFIC SCIENTIFIC DOES NOT SEPARATELY WARRANT THE RESULTS OF ANY SUCH CORRECTION OR WARRANT THAT ANY OR ALL FAILURES OR ERRORS WILL BE CORRECTED OR WARRANT THAT THE FUNCTIONS CONTAINED IN PACIFIC SCIENTIFIC’S PROGRAMS WILL MEET CUSTOMER’S REQUIREMENTS OR WILL OPERATE IN THE COMBINATIONS SELECTED BY CUSTOMER. This warranty for Programs is contingent upon proper use of the Programs and shall not apply to defects or failure due to: (i) accident, neglect, or misuse; (ii) failure of Customer’s equipment; (iii) the use of software or hardware not provided by Pacific Scientific; (iv) unusual stress caused by Customer’s equipment; or (v) any party other than Pacific Scientific who modifies, adjusts, repairs, adds to, deletes from or services the Programs. This warranty for Programs is valid for a period of ninety (90) days from the date Pacific Scientific first delivers the Programs to Customer.

---

THE FOREGOING WARRANTIES ARE IN LIEU OF ALL OTHER WARRANTIES (EXCEPT AS TO TITLE), WHETHER EXPRESSED OR IMPLIED, INCLUDING WITHOUT LIMITATION, ANY WARRANTY OF MERCHANTABILITY OR OF FITNESS FOR ANY PARTICULAR PURPOSE, AND ARE IN LIEU OF ALL OTHER OBLIGATIONS OR LIABILITIES ON THE PART OF PACIFIC SCIENTIFIC. PACIFIC SCIENTIFIC'S MAXIMUM LIABILITY WITH RESPECT TO THESE WARRANTIES, ARISING FROM ANY CAUSE WHATSOEVER, INCLUDING WITHOUT LIMITATION, BREACH OF CONTRACT, NEGLIGENCE, STRICT LIABILITY, TORT, WARRANTY, PATENT OR COPYRIGHT INFRINGEMENT, SHALL NOT EXCEED THE PRICE SPECIFIED OF THE PRODUCTS OR PROGRAMS GIVING RISE TO THE CLAIM, AND IN NO EVENT SHALL PACIFIC SCIENTIFIC BE LIABLE UNDER THESE WARRANTIES OR OTHERWISE, EVEN IF PACIFIC SCIENTIFIC HAS BEEN ADVISED OF THE POSSIBILITY OF SUCH DAMAGES, FOR SPECIAL, INCIDENTAL, OR CONSEQUENTIAL DAMAGES, INCLUDING WITHOUT LIMITATION, DAMAGE OR LOSS RESULTING FROM INABILITY TO USE THE PRODUCTS OR PROGRAMS, INCREASED OPERATING COSTS RESULTING FROM A LOSS OF THE PRODUCTS OR PROGRAMS, LOSS OF ANTICIPATED PROFITS, OR OTHER SPECIAL, INCIDENTAL, OR CONSEQUENTIAL DAMAGES, WHETHER SIMILAR OR DISSIMILAR, OF ANY NATURE ARISING OR RESULTING FROM THE PURCHASE, INSTALLATION, REMOVAL, REPAIR, OPERATION, USE OR BREAKDOWN OF THE PRODUCTS OR PROGRAMS, OR ANY OTHER CAUSE WHATSOEVER, INCLUDING NEGLIGENCE.

The foregoing shall also apply to Products, Programs, or parts for the same which have been repaired or replaced pursuant to such warranty, and within the period of time, in accordance with Pacific Scientific's date of warranty.

No person, including any agent, distributor, or representative of Pacific Scientific, is authorized to make any representation or warranty on behalf of Pacific Scientific concerning any Products or Programs manufactured by Pacific Scientific, except to refer purchasers to this warranty.

---

# Table of Contents

.....

<b>1 Overview of the OC940 SERCOS Option Card</b>	<b>1-1</b>
1.1 Interfaces and Connections	1-1
1.2 Setting up Serial Addresses using Switch S1	1-7
1.3 Identification Numbers	1-11
<b>2 Inputs/Outputs</b>	<b>2-1</b>
2.1 General Purpose I/O	2-1
2.2 BDIO Mapping	2-3
2.3 Probe/Registration Functionality	2-12
<b>3 Analog Inputs/Outputs</b>	<b>3-1</b>
3.1 Analog Input	3-1
3.2 Analog Output	3-1
3.3 DACMap Parameters	3-3
<b>4 Signature Series Wave Shaping</b>	<b>4-1</b>
<b>5 Servo Loop Gain Parameter Set Up</b>	<b>5-1</b>
5.1 Tuning Equations	5-1
5.2 Motor Commutation	5-4
5.3 System Protection	5-5
5.4 Advanced Velocity Loop Tuning	5-10
<b>6 IDN Attributes</b>	<b>6-1</b>
6.1 SERCOS Specific Parameters	6-1
6.2 Manufacturer Specific Parameters	6-54

## Index

---

# 1 Overview of the OC940 SERCOS Option Card

---

**Introduction** This chapter introduces the OC940 SERCOS Option Card. Topics covered are:

- OC940 Overview
- OC940 Connection Diagram
- Setting up Serial Address Using Switch S1
- List of Supported IDNs

---

## OC940 overview

The OC940 SERCOS Option Card can be installed in a Pacific Scientific SC900 Servocontroller. The OC940 contains all the hardware and firmware necessary to connect these drives to a SERCOS network.

This chapter explains how to wire a SC940 system, outlines I/O specifications, defines jumper settings, and lists the SERCOS IDNs which the OC940 will support.

---

## 1.1 Interfaces and Connections

---

**Introduction** The diagrams on the following pages show the connections for inputs and outputs for the SC940.



### IMPORTANT NOTE

**The OC940 requires 3.25 inches of clearance for connectors and lead dress at the front of the controller. This must be considered when selecting a cabinet for a SC940 servo drive.**

## OC940 connection diagram

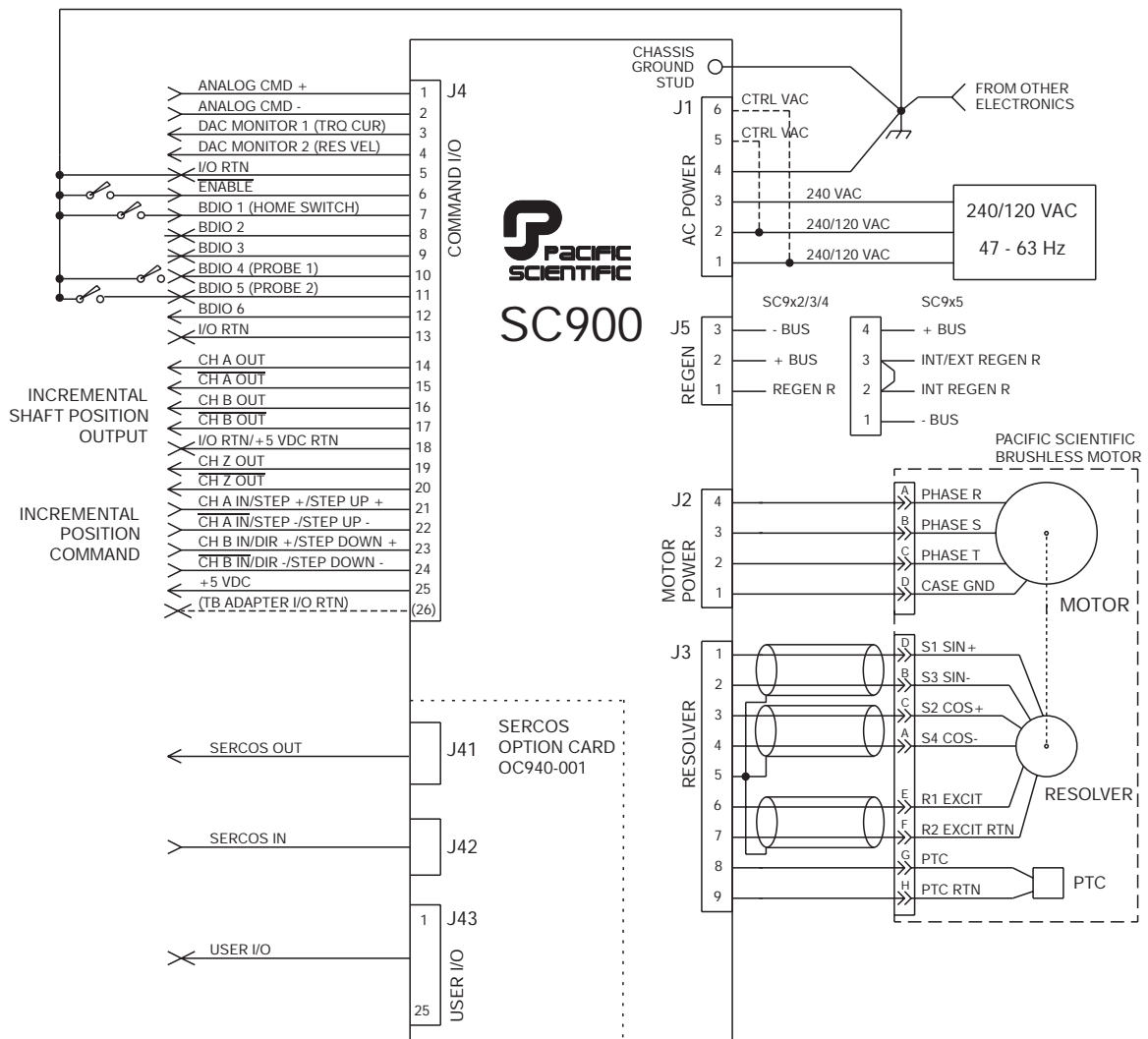

**Note:** Default functions for J4 connections are reprogrammed by the OC940. This configuration does not match the base SC900 configuration.

OC940  
connection  
diagram

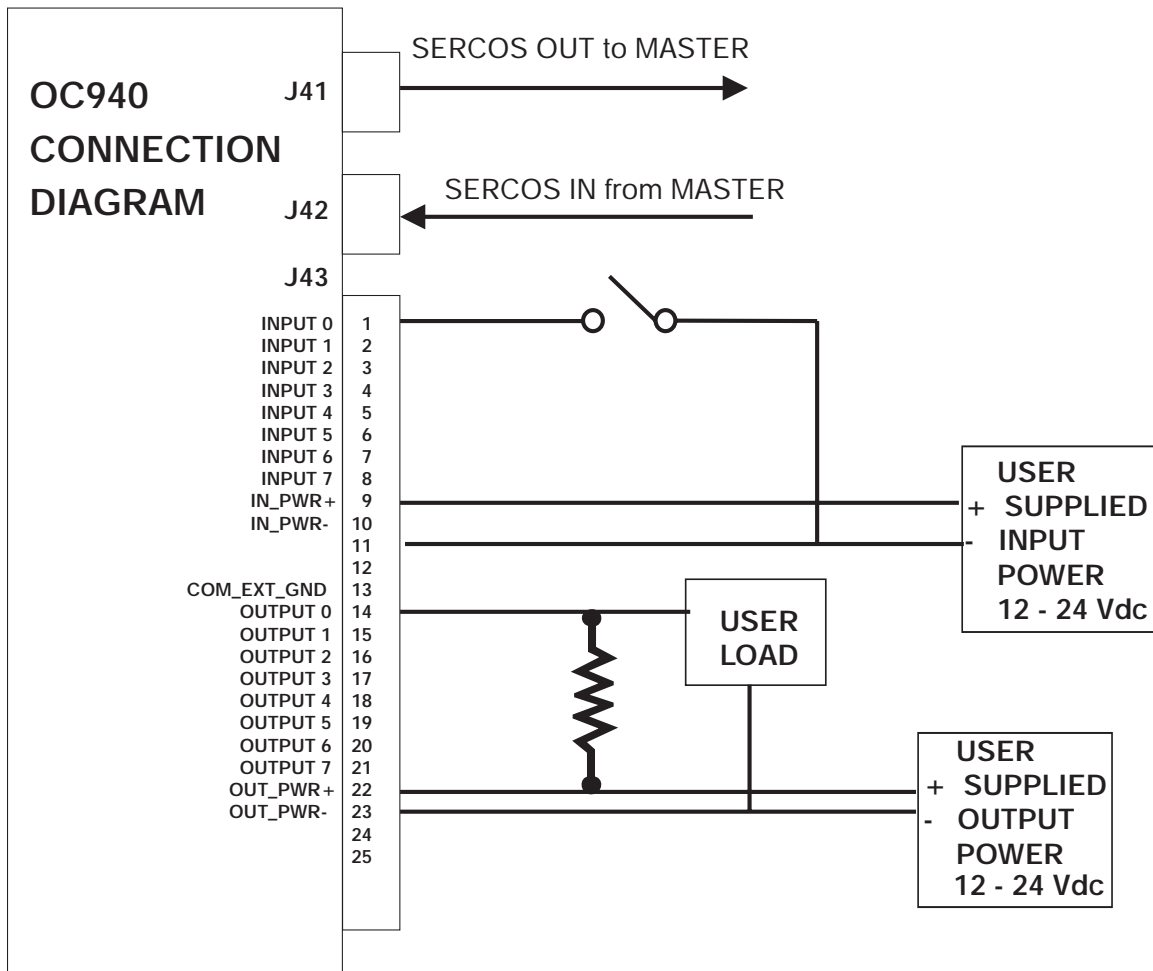



---

## I/O Specifications

- The front of the OC940 will have a DB25 connector for 8 Input and 8 Output I/O connections, each with their own power supply signals from the I/O source.
- The OC940 Inputs have a 4.42 Kohm pull up resistor to the user supplied voltage on IN-PWR(+). The input can source up to 3.75mA when the user supply uses 24 Vdc.
- User Input supply voltage must be between 12 to 24 Volts.
- The Input trip voltage is 50% of the user supply voltage.
- Each input has hysteresis of 1.3 Volts.
- The OC940 Outputs have a maximum sinking capability of 250 mA each through an open drain configuration. Pull up resistors are required at the user load.
- This board will support an Output Voltage between 12 and 24 Volts.
- Both the Inputs and Outputs require the user to provide the I/O power source to the board.

## I/O Circuit diagram

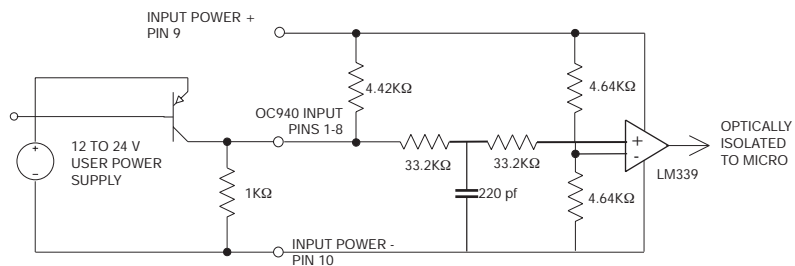
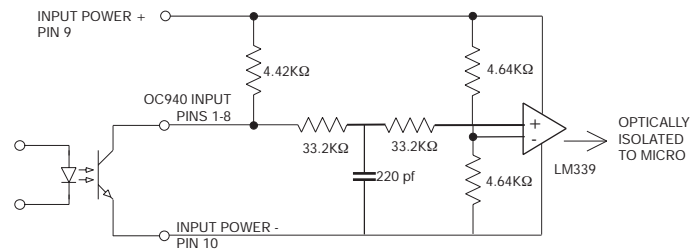
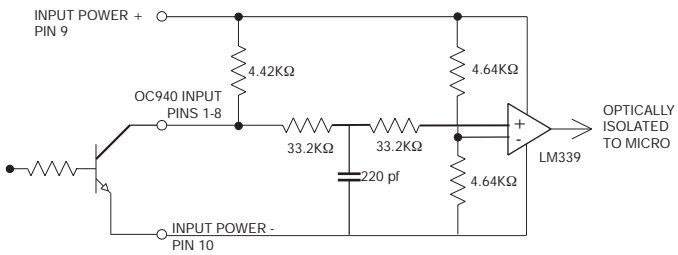
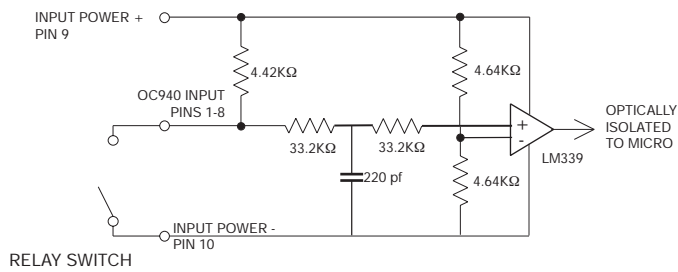

## OC940 outputs

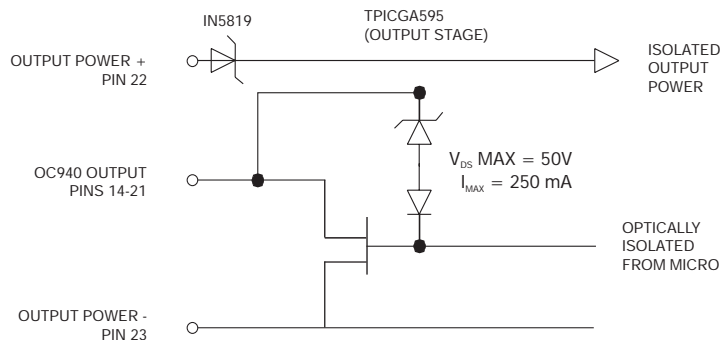

## Jumper settings

The OC940 has three jumpers. The settings are as follows:

Jumper	Position	Explanation
<b>E1:</b> Baud rate selection	1-2	<b>2 Mbaud (default)</b>
	2-3	4 Mbaud
<b>E2</b>	1-2	N/A
	2-3	Required
<b>E3:</b> Optical Power Transmit level	1-2	Low power transmission (default)
	2-3	High power transmission

## LEDs

The OC940 has two LEDs:

Phase	LEDs	Phase	LEDs
0	Both OFF	3	1 Blinking, 1 ON
1	1 OFF, 1 Blinking	4	Both ON
2	1 OFF, 1 ON	Fault	Both Blinking

---

## 1.2 Setting up Serial Addresses Using Switch S1

---

### Definition

The S1 switch:

- sets the address required for each node on the SERCOS ring

---

### Procedure

The following diagram shows the location of switch S1. The view shows the location of the S1 switch looking down at the OC940.

**Note:** *Each OC940 must have a unique serial address.*

### Switch location

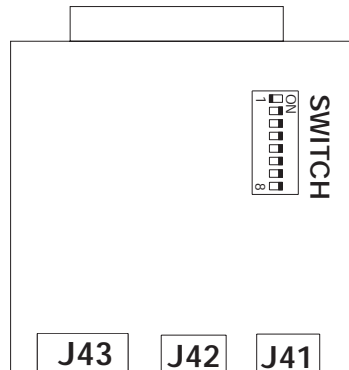

### Switch S1

The diagram below shows the S1 switch settings.

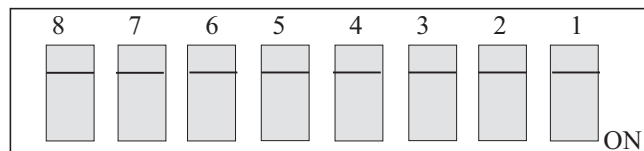

The switches are:

- ON in the down position (away from number)
- OFF in the up position (toward number)

---

**Procedure**

1. Remove power from the SC900 servocontroller.
2. Refer to the table below to set the OC940 to the appropriate address.

**S1 address table**

Address	1	2	3	4	5	6	7	8
0*	On	On	On	On	On	On	On	On
1	Off	On	On	On	On	On	On	On
2	On	Off	On	On	On	On	On	On
3	Off	Off	On	On	On	On	On	On
4	On	On	Off	On	On	On	On	On
5	Off	On	Off	On	On	On	On	On
6	On	Off	Off	On	On	On	On	On
7	Off	Off	Off	On	On	On	On	On
8	On	On	On	Off	On	On	On	On
9	Off	On	On	Off	On	On	On	On
10	On	Off	On	Off	On	On	On	On
11	Off	Off	On	Off	On	On	On	On
12	On	On	Off	Off	On	On	On	On
13	Off	On	Off	Off	On	On	On	On
14	On	Off	Off	Off	On	On	On	On
15	Off	Off	Off	Off	On	On	On	On
16	On	On	On	On	Off	On	On	On
17	Off	On	On	On	Off	On	On	On

---

**S1 address  
table (cont'd)**

<b>Address</b>	<b>1</b>	<b>2</b>	<b>3</b>	<b>4</b>	<b>5</b>	<b>6</b>	<b>7</b>	<b>8</b>
18	On	Off	On	On	Off	On	On	On
19	Off	Off	On	On	Off	On	On	On
20	On	On	Off	On	Off	On	On	On
21	Off	On	Off	On	Off	On	On	On
22	On	Off	Off	On	Off	On	On	On
23	Off	Off	Off	On	Off	On	On	On
24	On	On	On	Off	Off	On	On	On
25	Off	On	On	Off	Off	On	On	On
26	On	Off	On	Off	Off	On	On	On
27	Off	Off	On	Off	Off	On	On	On
28	On	On	Off	Off	Off	On	On	On
29	Off	On	Off	Off	Off	On	On	On
30	On	Off	Off	Off	Off	On	On	On
31	Off	Off	Off	Off	Off	On	On	On
32	On	On	On	On	On	Off	On	On
33	Off	On	On	On	On	Off	On	On
34	On	Off	On	On	On	Off	On	On
35	Off	Off	On	On	On	Off	On	On

.  
.  
.

**S1 address  
table (cont'd)**

<b>Address</b>	<b>1</b>	<b>2</b>	<b>3</b>	<b>4</b>	<b>5</b>	<b>6</b>	<b>7</b>	<b>8</b>
240	On	On	On	On	Off	Off	Off	Off
241	Off	On	On	On	Off	Off	Off	Off
242	On	Off	On	On	Off	Off	Off	Off
243	Off	Off	On	On	Off	Off	Off	Off
244	On	On	Off	On	Off	Off	Off	Off
245	Off	On	Off	On	Off	Off	Off	Off
246	On	Off	Off	On	Off	Off	Off	Off
247	Off	Off	Off	On	Off	Off	Off	Off
248	On	On	On	Off	Off	Off	Off	Off
249	Off	On	On	Off	Off	Off	Off	Off
250	On	Off	On	Off	Off	Off	Off	Off
251	Off	Off	On	Off	Off	Off	Off	Off
252	On	On	Off	Off	Off	Off	Off	Off
253	Off	On	Off	Off	Off	Off	Off	Off
254	On	Off	Off	Off	Off	Off	Off	Off
255**	Off	Off	Off	Off	Off	Off	Off	Off

\*Repeater Application Only

\*\*Not Allowed for SERCOS Applications

3. Re-connect power to the SC900 with OC940.
4. Repeat steps 1 through 4 for other units on the ring. Make sure to give the other units unique addresses.

---

## 1.3 Identification Numbers (IDNs)

---

**Introduction** This is the list of SERCOS IDNs which are supported by the OC940 SERCOS Option Card. For additional information on each IDN please consult a SERCOS specification or Chapter 6.

---

**List of supported IDNs**

- 1 Control Unit Cycle Time (TNcvc)
- 2 Communication Cycle Time (Tscvc)
- 3 Shortest AT Transmission Starting Time (T1min)
- 4 Transmit/Receive Transition Time (TATMT)
- 5 Minimum Feedback Processing Time (T4min)
- 6 AT Transmission Starting Time (T1)
- 7 Feedback Acquisition Capture Point (T4)
- 8 Command Value Valid Time (T3)
- 9 Position of Data Record in MDT
- 10 Length of Master Data Telegram
- 11 Class 1 Diagnostic
- 14 Interface Status
- 15 Telegram Type Parameter
- 16 Configuration List of AT
- 17 IDN List of all Operation Data
- 18 IDN List of Operation Data for CP2
- 19 IDN List of Operation Data for CP3
- 21 IDN List of Invalid Operation Data for CP2
- 22 IDN List of Invalid Operation Data for CP3
- 24 Configuration List of the MDT
- 25 IDN List of all Procedure Commands



---

<b>IDNs (Cont'd)</b>	28	MST Error Counter
	29	MDT Error Counter
	32	Primary Operation Mode
	36	Velocity Command Value
	40	Velocity Feedback Value
	41	Homing Velocity
	42	Homing Acceleration
	43	Velocity Polarity Parameter
	44	Velocity Data Scaling Type
	45	Velocity Data Scaling Factor
	46	Velocity Data Scaling Exponent
	47	Position Command Value
	51	Position Feedback Value 1 (Motor Feedback)
	52	Reference Distance 1
	55	Position Polarity Parameter
	76	Position Data Scaling Type
	77	Linear Position Data Scaling Factor
	78	Linear Position Data Scaling Exponent
	79	Rotational Position Resolution
	80	Torque Command Value
	82	Positive Torque Limit Value
	83	Negative Torque Limit Value
	84	Torque Feedback Value
	85	Torque Polarity Parameter
	88	Receive to Receive Recovery Time (TMTSY)
	89	MDT Transmission Starting Time (T2)

---

<b>IDNs (Cont'd)</b>	90	Command Value Proceeding Time (TMTSG)
	95	Diagnostic Message
	96	Slave Arrangement
	99	Reset Class 1 Diagnostic
	100	Velocity Loop Proportional Gain (kvp)
	101	Velocity Loop Integral Action Time (kvi)
	103	Modulo Value
	104	Position Loop Kv Factor (kpp)
	106	Current Loop Proportional Gain 1 (kip)
	107	Current Loop Integral Action Time 1 (kii)
	108	Feedrate Override
	110	Amplifier Peak Current
	123	Feed Constant
	127	Communications Phase 3 Transition Check
	128	Communications Phase 4 Transition Check
	129	Manufacturer Class 1 Diagnostic
	130	Probe Value 1 Positive Edge
	131	Probe Value 1 Negative Edge
	132	Probe Value 2 Positive Edge
	133	Probe Value 2 Negative Edge
	138	Bipolar Acceleration Limit Value
	140	Controller Type
	143	SYSTEM Interface Version
	147	Homing Parameter
	148	Drive-Controlled Homing Procedure Command
	159	Monitoring Window

---

<b>IDNs (Cont'd)</b>	160	Acceleration Data Scaling Type
	161	Acceleration Data Scaling Factor
	162	Acceleration Data Scaling Exponent
	169	Probe Control Parameter
	170	Probing Cycle Procedure Command
	185	Length of the Configurable Data Record in the AT
	186	Length of the Configurable Data Record in the MDT
	187	IDN List of Configurable data in the AT
	188	IDN List of Configurable data in the MDT
	189	Following Distance (PosErrorMax)
	301	Allocation of Real-Time Control Bit 1
	303	Allocation of Real-Time Control Bit 2
	305	Allocation of Real-Time Status Bit 1
	307	Allocation of Real-Time Status Bit 2
	400	Home Switch
	401	Probe 1
	402	Probe 2
	403	Position Feedback Value Status
	405	Probe 1 Enable
	406	Probe 2 Enable
	409	Probe 1 Positive Latched
	410	Probe 1 Negative Latched
	411	Probe 2 Positive Latched
	412	Probe 2 Negative Latched

---

**IDNs (Cont'd)**

32800 DSP Debug Address  
32801 DSP Debug Word  
32802 DSP Debug DWord  
32803 Pacific Scientific Defined - **DO NOT ACCESS**  
32804 Slave Tx Level  
32805 Pacific Scientific Defined - **DO NOT ACCESS**  
32806 Pacific Scientific Defined - **DO NOT ACCESS**  
32807 Pole Count  
32808 PosErrorMax  
32809 Filter Value for ADF0  
32810 DM1F0  
32811 DM2F0  
32812 DM1Gain  
32813 DM2Gain  
32814 DM1Map - Mux Select  
32815 DM2Map - Mux Select  
32816 EncOut  
32817 BDIOMap1  
32818 BDIOMap2  
32819 BDIOMap3  
32820 BDIOMap4  
32821 BDIOMap5  
32822 BDIOMap6  
32823 EncInFilt  
32824 RemoteFB  
32825 BDLgcThr

---

<b>IDNs (cont'd)</b>	32826 CommOff
	32827 EncMode
	32828 EncIn
	32829 ITThresh
	32830 StopTime
	32831 VBusThresh
	32832 VelLmtHi
	32833 VelLmtLo
	32834 Pacific Scientific Defined - <b>DO NOT ACCESS</b>
	32835 CoastTime
	32836 CommEnbl
	32837 Motor
	32840 Kvff
	32841 ARZ0
	32842 ARZ1
	32843 ARF0
	32844 ARF1
	32845 Firmware version
	32846 Encoder Data Scaling Method
	32847 Encoder Modulo Value
	32848 WaveShape Coefficient List IDN
	32853 CommSrc (Commutation Source)
	32854 Align Encoder Commutation Command

---

<b>IDNs (cont'd)</b>	34855 NVSave
	34856 NVLoad
	34857 ResPos (Resolver Position)
	34816 OC940 Input Bit #0
	34817 OC940 Input Bit #1
	34818 OC940 Input Bit #2
	34819 OC940 Input Bit #3
	34820 OC940 Input Bit #4
	34821 OC940 Input Bit #5
	34822 OC940 Input Bit #6
	34823 OC940 Input Bit #7
	34824 OC940 Input Port
	34825 AnalogIn
	34826 EncPos (Encoder Position)
	34832 OC940 Output Bit #0
	34833 OC940 Output Bit #1
	34834 OC940 Output Bit #2
	34835 OC940 Output Bit #3
	34836 OC940 Output Bit #4
	34837 OC940 Output Bit #5
	34838 OC940 Output Bit #6
	34839 OC940 Output Bit #7
	34840 OC940 Output Port
	34841 AnalogOut1
	34842 AnalogOut2
	34849 BDIO Input1

---

<b>IDNs (cont'd)</b>	34850 BDIO Input2
	34851 BDIO Input3
	34852 BDIO Input4
	34853 BDIO Input5
	34854 BDIO Input6
	34855 BDIO Input Port
	34857 BDIO Output1
	34858 BDIO Output2
	34859 BDIO Output3
	34860 BDIO Output4
	34861 BDIO Output5
	34862 BDIO Output6
	34863 BDIO Output Port

---

## Section 2 - Inputs/Outputs

---

**Introduction**      The OC940 has 8 inputs and 8 outputs that are not mappable. In addition, the SC900 base unit has 6 Bi-Directional Input/Output (BDIO) pins which are mappable.

### 2.1 General Purpose Inputs/Outputs

---

The OC940 Input and Output pins are optically isolated from the rest of the OC940 and each other.

Below is a table of the applicable IDNs for the OC940 General Purpose I/O:

<b>IDN(s)</b>	<b>Description</b>	<b>Function</b>
34816-34823	OC940 Input Bits (0-7)	Read Input Bit (0-7)
34824	OC940 Input Port	Read Entire Input Port
34832-34839	OC940 Output Bits (0-7)	Read/Write Output Bits (0-7)
34840	OC940 Output Port	Read/Write Entire Output Port

**Service Channel**      All of the above IDNs can be read through the SERCOS Service Channel. Reading an input bit would return the value of the bit located in the input port. Reading IDN 34824 would return the value of all the input bits as a single word. Reading an output bit would return the value the OC940 is attempting to drive on the output pin. Reading IDN 34840 would return the value the OC940 is attempting to drive on all the output pins.



---

**Example**

The OC940 has 01010101 on its input pins.

The OC940 is attempting to drive 10101010 on its output pins.

Reading IDN 34824 would return 0x55.

Reading IDN 34816 would return a 1 (bit zero in the input byte).

Reading IDN 34817 would return a 0 (bit one in the input byte).

Reading IDN 34820 would return a 1 (bit four in the input byte).

Reading IDN 34840 would return 0xAA

Reading IDN 34832 would return a 0 (bit zero in the output byte).

Reading IDN 34833 would return a 1 (bit one in the output byte).

Reading IDN 34836 would return a 0 (bit four in the output byte).

---

**Cyclic Channel**

The only two OC940 I/O IDNs which can be placed in the cyclic channel are IDN 34824 (Input Port) and IDN 34840 (Output Port). IDN 34824 (Input Port) can be placed in the AT and returns 2 bytes of data. The AT data would have the input port in the low byte of the return AT data and a zero in the high byte. IDN 34840 (Output Port) can be placed in the MDT and allows the user to write to the output pins once every MST cycle. The low byte of the written data would be placed into the output port, the high byte is ignored.

**Real Time Control/Status**

All of the input bit IDNs (34816 - 34823) and output bit IDNs (34832 - 34839) can be used through the use of real time control/status bits.

Use Control Bit IDNs (301 or 303) to update up to two output points within the cyclic channel update time. Writing an output bit IDN into either of the two allocation of control bit IDNs will cause the value of the real time control bit in the MDT to be placed into that output bit. Example, write one of the output bit IDNs (34832 - 34839) into IDN 301 or IDN 303. Then use the output bit IDN (Ex. 34832) to set the state of the output point. It will be updated within the cyclic channel update time.

---

Use Status Bit IDNs (305 or 307) to update up to two input points within the cyclic channel update time. Writing an input bit IDN into either of the two allocation of status bit IDNs will cause the value of the input bit to appear in the real time status bit returned in the AT. Example, write one of the input bit IDNs (34816 - 34823) into IDN 305 or IDN 307. Then use the input bit IDN (Ex. 34816) to read the state of the input point. It will be updated within the cyclic channel update time.

#### **Example**

Writing 34816 (OC940 Input Bit #0) to IDN 305 (Allocation of Real Time Status Bit 1) will cause the value of Input Bit #0 to appear as Status Bit 1 in the cyclic AT status word.

Writing 34822 (OC940 Input Bit #6) to IDN 307 (Allocation of Real Time Status Bit 2) will cause the value of Input Bit #6 to appear as Status Bit 2 in the cyclic AT status word.

Writing 34834 (OC940 Output Bit #2) to IDN 303 (Allocation of Real Time Control Bit 2) will cause the value of Control Bit 2 in the cyclic MDT to be written to Output Bit #2.

Writing 34839 (OC940 Output Bit #7) to IDN 301 (Allocation of Real Time Control Bit 1) will cause the value of Control Bit 1 in the cyclic MDT to be written to Output Bit #7.

## **2.2 BDIO Mapping**

### **Introduction**

The SC900 Family features programmable Bi-Directional Input/Output (BDIO) pins which can be read and controlled over SERCOS. To use a BDIO pin as any input function, including general purpose inputs, the state of that BDIO output must be inactive (set to 1). The BDIOMap variables allow BDIO pins to be associated with pre-defined SC900 I/O functions. To use the BDIO as a general purpose input or output, the associated BDIOMap must be set to Function Number 0, General Purpose I/O.

---

### Input functions

Available Input functions are:

CWInh	Clockwise Motion Inhibit
CCWInh	Counter-Clockwise Motion Inhibit
HomeSwitch	Home Switch Input (by convention assigned to BDIOMap1 if it is active)
Probe1	Implemented in hardware on BDIO4 ( <b>Not Mappable</b> )
Probe2	Implemented in hardware on BDIO5 ( <b>Not Mappable</b> )

**Note:** *Probe1 and Probe2 functionality is not mappable. If Probe functionality is not required, these pins can be used as general purpose I/O (BDIOMap = 0) or mapped to any BDIO function (BDIOMap ≠ 0).*

---

### Output functions

Available Output functions are:

Fault	Active if drive is faulted
Enabled	Active if drive is enabled
Brake	Active if brake should be OFF
MechRev	Active for one half a resolver cycle, inactive for other half.
ElecRev	Active for one half an electrical cycle, inactive for other half.

---

**IDNs  
32817 - 32822**

These are the BDIOMapX IDNs which set the logical functions of the BDIOs on J4-7 to J4-12. Bits must be set to determine the polarity, Input or Output, and the function. The default settings for BDIOMap1 (IDN 32817) - BDIOMap6 (IDN 32822) are shown in the following table:

<b>BDIO Number</b>	<b>Default State</b>	<b>Default Function</b>	<b>Default Polarity</b>	<b>Default Value</b>
BDIOMap1 (IDN 32817)	General Purpose I/O	General Purpose I/O	Active High	0x0
BDIOMap2 (IDN 32818)	General Purpose I/O	General Purpose I/O	Active High	0x0
BDIOMap3 (IDN 32819)	General Purpose I/O	General Purpose I/O	Active High	0x0
BDIOMap4 (IDN 32820)	General Purpose I/O	General Purpose I/O	Active High	0x0
BDIOMap5 (IDN 32821)	General Purpose I/O	General Purpose I/O	Active High	0x0
BDIOMap6 (IDN 32822)	General Purpose I/O	General Purpose I/O	Active High	0x0

---

## Bit settings

To change the default settings follow the bit settings listed below.

**Note:** For general purpose I/O, the function number must be set to zero, with bits 30 and 31 also set to zero. To function as a general purpose Input, the user must write "I" to the output latch of that pin.

Bit #	Description
31	Polarity 0 = Active High 1 = Active Low
30	Input or Output 0 = Output 1 = Input
4-29	Must be 0
0-3	Determine the function of the input or output. Refer to the Input and Output function tables below.

## Input functions

The following table lists the input function numbers.

Function Name	Function #
General Purpose Input	0
CwInh	5
CcwInh	6
HomeSwitch	8

---

## Output functions

The following table lists the output function numbers.

Function Name	Function #
General Purpose Output	0
Fault	1
Enabled	2
Brake	3
MechRev	4
ElecRev	5

---

## BDIO IDNs

The following table lists the applicable IDNs for OC940 BDIO.

IDN(s)	Description	Function
34849-34854	BDIO Input Bits (1-6)	Read BDIO Input Bit (1-6)
34855	BDIO Input Port	Read BDIO Entire Input Port
34857-34862	BDIO Output Bits (1-6)	Read/Write Output Bits (1-6)
34863	BDIO Output Port	Read/Write Entire BDIO Output Port

---

### Reading/writing general purpose BDIO

In order to set a pin as a general purpose input or output, the BDIO Map IDN must be set to zero. Reading a BDIO Input pin would return the value of the input pin. Reading IDN 34855 would return the value of all the input pins as a single word.

Reading an Output pin would return the appropriate bit value located in the BDIO Output port. Reading IDN 34863 would return the value of the BDIO Output port. For a BDIO pin to be used as an INPUT function, the corresponding bit in the Output port must be set to a '1'.

Writing a 0 or 1 to IDNs 34857-34862 (BDIO Output Pins) will set BDIO Output Pins to that value, or writing a value between 0 and 63 to IDN 34863 (BDIO Output Port) will set the BDIO Output port to that value, assuming there are no other drivers on that line pulling the line low. Subsequently reading IDNs 34857-34862 (BDIO Output Pins) or IDN 34863 (BDIO Output Port) will return the current Output Port value, assuming a user-supplied pull-up resistor and no other output driver pulling the line low.

---

### Example

To change the mapping of BDIOMap1 from General Purpose Input (default) to the Home Switch, perform the following:

1. Write 0xC0000008 to BDIOMap1 (IDN 32817).
2. Read the first bit of the BDIO Input Port (IDN 34855) or read BDIO Input Pin 1 (IDN 34849) to monitor the state of the input.

**Note:** *IDN 34849 can only be read using the service channel. IDN 34855 can be read using the service channel or the cyclic channel.*

---

**Example**

Reading IDN 32818 (BDIOMap2) returns a 0x0. This indicates that BDIO2 is configured as a general purpose input/output.

To change the configuration of BDIOMap2 to be active LOW, FaultOut signal, write 0x80000001 to IDN 32818 (BDIOMap2).

If BDIOMap2 is configured as Fault Out, active low (IDN 32818 = 0x80000001) and there are no system faults, this results in BDIO pin #2 being high. If the user writes a '1' to IDN 34858 (BDIO Output Pin 2), the BDIO pin #2 will go high until a fault occurs, rewriting this value to a zero.

---

**Cyclic Channel**

The only two BDIO IDNs which can be placed in the cyclic channel are IDN 34855 (BDIO Input Port) and IDN 34863 (BDIO Output Port). IDN 34855 (BDIO Input Port) can be placed in the AT and returns 2 bytes of data. The AT data would have the BDIO Input port in the low byte of the return AT data and a zero in the high byte. IDN 34863 (BDIO Output Port) can be placed in the MDT and allows the user to write to the BDIO output port once every MST cycle. The low byte of the written data would be placed into the BDIO Output port, the high byte is ignored. Any BDIO Output Pins defined other than general purpose output (BDIO Map  $\neq$  0), will have the data overwritten when the output function is performed and its status written to the output port.



---

---

**Real Time Control/Status**

All of the BDIO Input Bit IDNs (IDNs 34849 - 34854) and Output Bit IDNs (IDNs 34857 - 34862) can be used through the use of real time control/status bits. Writing the IDN of the Input Bit into either of the two Allocation of Status Bit IDNs (IDN 305 or IDN 307) will cause the value of the input bit to appear in the real time status bit returned in the AT. Writing the IDN of the Output Bit into either of the two Allocation of Control Bit IDNs (IDN 301 or IDN 303) will cause the value of the real time control bit in the MDT to be placed into that Output Bit. Any mapped BDIO Outputs (BDIO Map  $\neq$  0), will be overwritten when the output function is performed (every 2 msec). Only general purpose BDIO Outputs (BDIO Map = 0) will retain their values.

---

**Example**

Writing 34849 (BDIO Input Pin #1) to IDN 305 (Allocation of Real Time Status Bit 1) will cause the value of BDIO Input Word Bit #1 to appear as Status Bit 1 in the cyclic AT status word.

Writing 34854 (BDIO Input Pin #6) to IDN 307 (Allocation of Real Time Status Bit 2) will cause the value of BDIO Input Pin #6 to appear as Status Bit 2 in the cyclic AT status word.

Writing 34858 (BDIO Output Pin #2) to IDN 303 (Allocation of Real Time Control Bit 2) will cause the value of Control Bit 2 in the cyclic MDT to be written to BDIO Output Pin #2. BDIO Map 2 (IDN 34818) should be set to zero for correct operation.

Writing 34861 (BDIO Output Pin #5) to IDN 301 (Allocation of Real Time Control Bit 1) will cause the value of Control Bit 1 in the cyclic MDT to be written to BDIO Output Pin #5. BDIO Map 5 (IDN 34821) should be set to zero for correct operation.

## Guidelines

- For a BDIO pin to function as an input, the user must write a '1' to the output latch of that pin.
- Each BDIO can be set to a special function independently of any other BDIO.
- BDIO 4 and 5 can be set to any other BDIO function when they are not being used for probe/registration functionality.
- Writing to a BDIO which is set to an Output Function, such as FAULT OUT, results in the output pin being set to the written value until the Output Function overwrites (every 2 msec) the written value.

## BDIO Schematic

BDIn1-6: IDNs 34849 - 34854  
BDOut1-6: IDNs 34857 - 34862  
BDLgcThres: IDN 32825

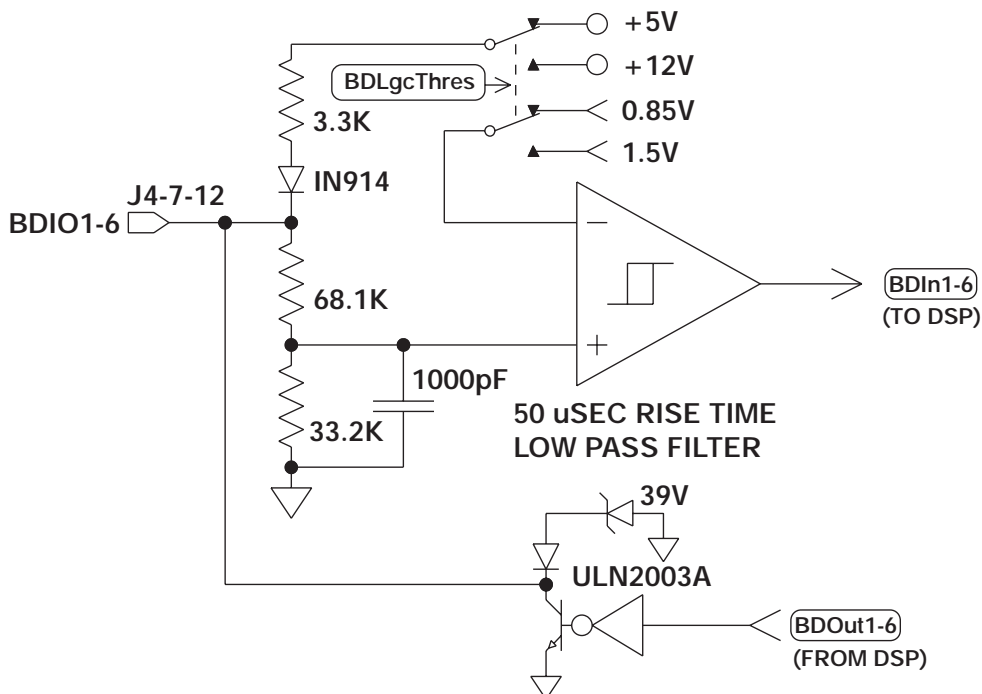

---

## 2.3 Probe/Registration Functionality

---

### Introduction

In a typical application, probes are used to define the position of a part or the depth of a hole or cut. When the probe touches the surface, the switch closes and the position data is latched.

Position registration uses the closure of a proximity switch, photo eye, or similar device to signal the latching of position data.

On the SC940, during probing and registration, position latching is performed by the drive.

---

### Guidelines

The PROBE 1 function must reside on BDIO4 when probe/registration is in use.

The PROBE 2 function must reside on BDIO5 when probe/registration is in use.

The two probe functions work identically, but require additional setup prior to use when compared to other BDIO Input functions.

**Note:** *When RemoteFB = 1 or 2 (IDN 32824), Probe 2 cannot be used to latch position. Probe 2 is used only as the marker pulse input for homing. Probe 1 can be used to latch position (encoder position). When RemoteFB = 0, Probe 1 and Probe 2 can be used to latch position (resolver position).*

---

**Probe table**

Below is a list of IDNs related to the Probe BDIO functionality:

<b>IDN</b>	<b>Description</b>	<b>Function</b>
130	Probe 1 Positive Edge	Returns Probe 1 Positive Edge Data
131	Probe 1 Negative Edge	Returns Probe 1 Negative Edge Data
132	Probe 2 Positive Edge	Returns Probe 2 Positive Edge Data
133	Probe 2 Negative Edge	Returns Probe 2 Negative Edge Data
169	Probe Control	Specifies which probe edges are active
170	Probe Cycle Command	Allows the beginning of a probe cycle
401	Probe 1	Returns the current state of Probe 1 pin.
402	Probe 2	Returns the current state of Probe 2 pin.
405	Probe 1 Enable	Enables the latching of data upon a Probe 1 edge.
406	Probe 2 Enable	Enables the latching of data upon a Probe 2 edge.
409	Probe 1 Positive Latched	Returns a '1' when Probe 1 Positive Edge data has been latched.
410	Probe 1 Negative Latched	Returns a '1' when Probe 1 Negative Edge data has been latched.
411	Probe 2 Positive Latched	Returns a '1' when Probe 2 Positive Edge data has been latched.
412	Probe 2 Negative Latched	Returns a '1' when Probe 2 Negative Edge data has been latched.

**Service channel operation**

All of the above IDNs can be accessed through the Service Channel. For the probe function to take place, several of the IDNs must be set up prior to an event.

---

IDN 169

**Probe Control Parameter:**

Bit Number	Setting
0 - Probe 1 Positive Edge	0 = Positive edge inactive 1 = Positive edge active
1 - Probe 1 Negative Edge	0 = Negative edge inactive 1 = Negative edge active
2 - Probe 2 Positive Edge	0 = Positive edge inactive 1 = Positive edge active
3 - Probe 2 Negative Edge	0 = Negative edge inactive 1 = Negative edge active

IDN 170

**Probing Cyclic Procedure Command:** A probing cycle procedure must be active in order for a probe event to be captured. This is done by writing a 3 to IDN 170.

IDN 405

**Probe 1 Enable:** Probe 1 must be enabled in order to capture a probe 1 event.

Bit Number	Bit Setting
0	0 = Probe 1 Not Enabled 1 = Probe 1 Enabled

IDN 406

**Probe 2 Enable:** Probe 2 must be enabled in order to capture a probe 2 event.

Bit Number	Bit Setting
0	0 = Probe 2 Not Enabled 1 = Probe 2 Enabled

**Note:** *The above three items MUST be done to capture a probe event. They may be done in ANY order.*

Once the above items have been set, and the correct edge has occurred on the probe line, probe data will be latched.

---

Once the probe data are latched and ready to be sent to the Master, the correct Probe Latched bit (IDNs 409 - 412) will return a 1 when read.

- The latched position data can be read through IDNs 130 - 133.
- The initial default data is 0. Data are updated only after a probe event has occurred.
- The probe event can be reset by clearing any of the four control IDNs (IDNs 169, 170, 405/406) and then re-enabling them.

### Example

Writing 1 to IDN 169 (Probe Control Parameter) will cause Probe 1 Positive Edge events to be recorded. IDNs 405 and 170 must still be configured.

Writing 1 to IDN 405 (Probe 1 Enable) will enable probe 1.

Writing 3 to IDN 170 (Probe Command) will initiate probing on probe 1 (BDIO4) and probe 2 (BDIO5). At this point, if probe 1 (BDIO4) did not transition (low to high), reading IDN 409 (Probe 1 Positive Latch) will return a 0 indicating a probe did not take place. Reading IDN 130 (Probe 1 Positive Edge Data) will return 0.

After a positive transition on probe 1 (BDIO4), reading IDN 409 (Probe 1 Positive Latch) will return a 1 indicating a probe had occurred. Reading IDN 130 (Probe 1 Positive Edge Data) will return the latched position. To latch position on probe 1 again, reset IDN 405 by writing a 0 and then a 1 to it.

Since probe 2 was not enabled using IDNs 169 and 406, reading probe 2 related IDNs will return 0.

---

**Cyclic Channel**

Of all the Probe BDIO IDNs, only IDNs 130 - 133 (IDNs which return latched position data) can be inserted into the AT. The data returned will either be 0 (no data has been latched) or the last latched data for that probe edge.

**Real Time Control/Status Bits**

All of the Probe Data Latched IDNs (IDNs 409 - 412) and Probe Enable IDNs (IDNs 405 and 406) can be used through the use of real time control/status bits. Writing the IDN of a Probe Data Latched into either of the two Allocation of Status Bit IDNs (IDN 305 or IDN 307) will cause the value of that IDN to appear in the real time status bit returned in the AT. Writing the IDN of the Enable Probe into either of the two Allocation of Control Bit IDNs (IDN 301 or IDN 303) will cause the value of the real time control bit in the MDT to be placed into that Probe Enable function.

**Example**

Writing 409 (Probe 1 Positive Data Latched) to IDN 305 (Allocation of Real Time Status Bit 1) will cause the value of Probe 1 Positive Data Latched to appear as Status Bit 1 in the cyclic AT status word.

Writing 412 (Probe 2 Negative Data Latched) to IDN 307 (Allocation of Real Time Status Bit 2) will cause the value of Probe 2 Negative Data Latched to appear as Status Bit 2 in the cyclic AT status word.

Writing 406 (Probe 2 enable) to IDN 303 (Allocation of Real Time Control Bit 2) will cause the value of Control Bit 2 in the cyclic MDT to be written to Probe 2 Enable.

Writing 405 (Probe 1 Enable) to IDN 301 (Allocation of Real Time Control Bit 1) will cause the value of Control Bit 1 in the cyclic MDT to be written to Probe 1 Enable.

Use of the Real Time Control/Status bit IDNs (IDNs 405, 406, 409 - 412) along with the cyclic channel IDNs (130 - 133) results in registration events recorded and acted upon in real time.

---

## Section 3 - Analog Inputs/Outputs

---

### 3.1 Analog Input

---

This IDN can be read through either the Service or the Cyclic channel.

**IDN 34825** Allows the master to read the Analog Input on the base unit. The value of this IDN is:

$$\text{AnalogIn (V)} = \text{value read}/(954.3 * 2^{16})$$

### 3.2 Analog Output

---

The analog outputs can be set to various output functions, including a user specified voltage.

The Analog Output function is selected using the DACMAP IDNs (IDNs 32814 and 32815). The DACMAP functions must be 'OFF' (IDNs 32814 or 32815 = zero) for user controlled AnalogOut. AnalogOut1 can be written to using IDN 34841. AnalogOut2 can be written to using IDN 34842. The break frequencies for the Analog Outputs' low-pass filter are IDNs DM1F0 (IDN 32810) and DM2F0 (IDN 32811).

---

**IDN 32810** DM1F0 sets the frequency in Hz of a single pole low-pass filter on the DAC Monitor 1 output (J4-3). This IDN should be set so that:

$$\text{IDN 32810} = \text{Break Frequency (Hz)}$$

**IDN 32811** DM2F0 sets the frequency in Hz of a single pole low-pass filter on the DAC Monitor 2 output (J4-4). This IDN should be set so that:

$$\text{IDN 32811} = \text{Break Frequency (Hz)}$$



---

**Analog I/O IDNs** Below is a list of the Analog Input and Output IDNs:

IDN	Description	Function
32809	ADF0	Break Frequency for AnalogIn in Hz.
34825	AnalogIn	Analog Data Input
32810	DM1F0	Break Frequency for AnalogOut 1 in Hz.
32811	DM2F0	Break Frequency for AnalogOut 2 in Hz.
32812	DM1GAIN	Gain for AnalogOut1 - Scaling varies according to function
32813	DM2GAIN	Gain for AnalogOut2 - Scaling varies according to function.
32814	DM1MAP	Selects Variable to be mapped to AnalogOut1
32815	DM2MAP	Selects Variable to be mapped to AnalogOut2.
34841	AnalogOut1	Writes AnalogOut1 (If IDN 32814 = 0)
34842	AnalogOut2	Writes AnalogOut2 (If IDN 32815 = 0)

**Example**

User reads IDN 32809 (AnalogIn) to be 8000000.

Voltage on AnalogIn pin is:

$$8000000/(954.3*2^{16}) = 0.13 \text{ volts}$$

User reads IDN 32809 (AnalogIn) to be 200,000,000

Voltage on AnalogIn pin:

$$200,000,000/(954.3*2^{16}) = 3.2 \text{ volts}$$

**Note:** The analog input is a differential input to an A/D. The full scale differential command input range is  $\pm 13V$ .

---

### 3.3 DACMap Parameters

---

**IDN 32814** DM1Map selects the signal sent to the DAC Monitor 1 output on J4-3. This IDN should be set so that:

IDN 32814 = Monitor # from the table on the following page.

**IDN 32815** DM2Map selects the signal sent to the DAC Monitor 2 output on J4-4. This IDN should be set so that:

IDN 32815 = Monitor # from the table on the following page.

**Note:** *Set the value of the DM1Map and DM2Map (IDNs 32814 and 32815) before setting the values of DM1Gain and DM2Gain (IDNs 32812 and 32813).*

---

**IDN 32812** DM1Gain sets the multiplicative scale factor applied to the DM1Map selected signal before outputting on DAC Monitor 1 (J4-3) (DM1Gain). This IDN should be set so that:

IDN 32812 = DM1Gain

**IDN 32813** DM2Gain sets the multiplicative scale factor applied to the DM1Map selected signal before outputting on DAC Monitor 2 (J4-4) (DM2Gain). This IDN should be set so that:

IDN 32813 = DM2Gain

**DAC Out units**      The table below lists the units when DMxGain = 1.

Monitor #	Variable	Description	DAC Out Units
0	AnalogOutX		0.001 V/V
1	VelFB	Measured Velocity (DM2 Default)	0.001 V/kRPM
2	VelCmdA	Actual Velocity Command (VelCmdA)	0.001 V/kRPM
3	VelErr	Velocity Error	0.001 V/kRPM
4	FVelErr	Compensated Velocity Error	0.001 V/kRPM
5	Position	Measured Position*	0.001 V/Rev
6	PosError	Position Error*	0.001 V/Rev
7	PosCommand	Commanded Position*	0.001 V/Rev
8	ICmd	Commanded Torque Current	0.001 V/A
9	IFB	Measured Torque Current (DM1 Default)	0.001 V/A
10	AnalogIn	Filtered A/D Input	0.001 V/V
11	EncFreq	Encoder Frequency	0.001 V/Hz
12	EncPos	Encoder Position*	0.010 V/4096 counts
13	ItFilt	Filtered Output Current Amplitude	0.001 V/100%
14	HSTemp	Measured Heat Sink Temperature	0.001 V/C
15		Commutation Electrical Angle*	0.001V/Cycle
16	IR	Motor Phase R Output Current	0.001 V/A
17	IS	Motor Phase S Output Current	0.001 V/A
18	IT	Motor Phase T Output Current	0.001 V/A
19		Motor Phase R Voltage Duty Cycle	0.001V/100%
20		Motor Phase S Voltage Duty Cycle	0.001V/100%

Table (cont'd)

Monitor #	Variable	Description	DAC Out Units
21		Motor Phase T Voltage Duty Cycle	0.001V/100%
22	VBus	Drive Bus Voltage	0.001 V/V
23	ResPos	Resolver Absolute Position*	0.001 V/Rev
24		Commanded non-torque current	0.001 V/A
25		Measured non-torque current	0.001 V/A
26		Torque Voltage Duty Cycle	0.001 V/100%
27		Non-Torque Voltage Duty Cycle	0.001 V/100%
28		Velocity Command (VelCmd)	0.001 V/kRPM
65536	No change to variable, turn range clamp off		
65537	No change to variable, turn range clamp on		

\* - These variables are allowed to wrap around when the signal exceeds the output voltage range.

**Note:** *Dac monitor outputs have a range of  $\pm 5V$  with a resolution of  $10V/256 = 0.039 V$ .*

---

### Example

To view the velocity feedback (VelFB) signal on an oscilloscope (to measure overshoot, rise-time, or other motion performance parameters) do the following:

1. Command a 4 KRPM move. VelFB is the default setting for DM2Map (IDN 32815 = 1), therefore use DAC Monitor 2 (J4-4 with respect to pin 5).
2. To filter out noise, set DM2F0 (IDN 32811) to 1000 Hz. DAC Monitor 2 will display an analog signal representing VelFB.
3. Set DM2Gain (IDN 32813). The range of the DAC Monitors is  $\pm 5$  volts. Set DM2Gain so that the signal is not clamped and a high resolution signal is maintained.

For example, set DM2Gain so that 5 KRPM will correspond to 5 volts:

$$5 \text{ KRPM} * 0.001 \text{ Volt/KRPM} * \text{DM2Gain} = 5 \text{ Volts.}$$

This implies that  $\text{DM2Gain} = 1000$ .

4. Connect the scope probe to DAC Monitor 2 and command a move. The velocity feedback signal should be visible on the scope.

DACMap diagram

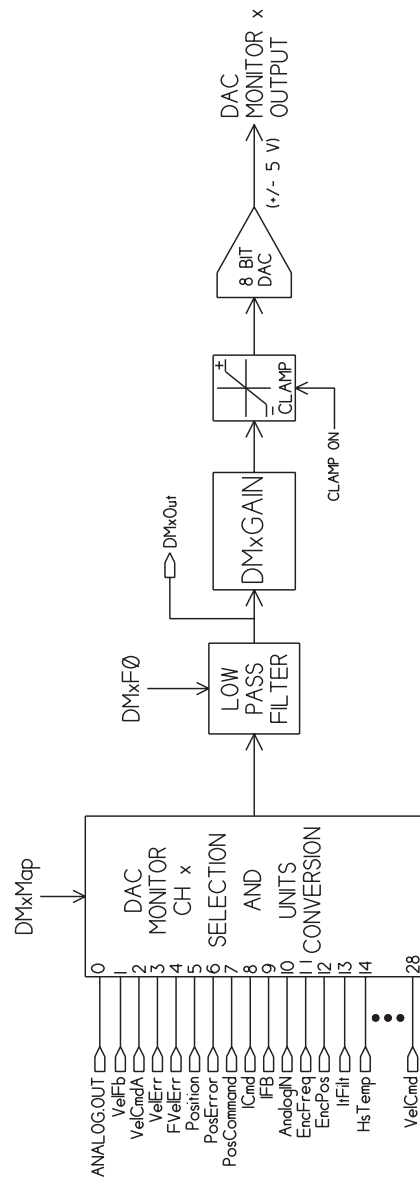

---

## Section 4 - Signature Series Wave Shaping

---

**Introduction** By power up default, the SC940 will use a pure sinusoidal wave shape for the motor terminal currents. This is sufficient for the vast majority of applications. It is possible, if needed, to customize the wave shape to account for a motor's back EMF wave shape that is not purely sinusoidal. Note that customizing the wave shape is typically unnecessary and need not be done. To customize the wave shape, the user must first write IDN 32848 (Wave Shape Coefficients List) and then IDN 32837 (Motor).

If the user does not require a custom wave shape, IDNs 32837 (Motor) and IDN 32848 (Wave Shape Coefficients List) can be ignored. The default values for these IDNs will be used.

---

**IDN 32837** The Motor variable is a 32-bit long unsigned long integer which is used to identify the waveshape downloaded to the SC900 controller using IDN 32848. By convention the 4 ASCII character abbreviation of the motor name is converted to an integer and downloaded along with the waveshape. The default value of this variable should be 0x53494E45 = 'S' (0x53) : 'I' (0x49) : 'N' (0x4E) : 'E' (0x45).

Used to assign a label to Wave Shape Generation Table created.

**Read** When waveshape table is compiled, and a Motor Label is assigned, this IDN returns the Motor Label.

When the waveshape table is not complete, not compiled, or has no Label assigned to it, this IDN returns 0000.

---

**Write** Allows the SERCOS Master to set the MOTOR Label and compile the waveshape table.

The Master can only write to this IDN when in Phase 2.

The Master can only write to this IDN when all 26 of the Wshape parameters have already been written using IDN 32848.

The fault code for failures in the above conditions is a Write Protection Fault.

Successfully writing the Motor Label also causes the Wshape table to be generated. The OC940 is not able to leave Phase 2 without a Motor Label.

---

**IDN Number  
32848**

WaveShapeCoefficient List

**Read** Reading the Wave Shape Coefficient List will display the 26 coefficients.

**Write** Writing the Wave Shape Coefficient List allows the SERCOS Master to set all the waveshape coefficients while in phase 2.

The waveshape is defined by a set of 26 numbers which are the coefficients (A,B) of a Fourier series representation of the line-to-neutral motor voltage

$$\sum [A \cos(n\Theta) - B \sin(n\Theta)] \text{ for } n =$$

1, 2, 4, 5, 7, 8, 10, 11, 13, 14, 16, 17, 19. The coefficients are represented as signed integers with a scaling of 1/32768 bit (-1.0 = -32768).



---

**Coefficient  
table**

<b>Harmonic</b>	<b>Cos coefficient value</b>	<b>Index#</b>	<b>Sin coefficient value</b>	<b>Index#</b>
1	0.00	0	-0.832153	1
2	0.00	2	0.00	3
4	0.00	4	0.00	5
5	0.00	6	0.00	7
7	0.00	8	0.00	9
8	0.00	10	0.00	11
10	0.00	12	0.00	13
11	0.00	14	0.00	15
13	0.00	16	0.00	17
14	0.00	18	0.00	19
16	0.00	20	0.00	21
17	0.00	22	0.00	23
19	0.00	24	0.00	25

---

## Section 5 - Servo Loop Gain Parameter Set Up

---

**Introduction** This section describes setting the parameters associated with the current, velocity and position loops. The user may need to adjust control loop parameters due to large mismatches between motor and load inertia, mechanical resonances, or backlash.

### 5.1 Tuning equations

---

#### Current Loop

**IDN 106** Current Loop Proportional Gain (KIP). This IDN should be set so that:

$$KIP \text{ v/amp} = L_{l-1} \text{ (in henries)} * 2 * \pi * 1000$$

$$IDN 106 = KIP \text{ (Volts/Amp)} * I_{Peak} * 405.6685e-3$$

**IDN 107** Current Loop Integral Gain (KII). This IDN should be set so that:

$$KII = 50 \text{ Hz}$$

$$IDN 107 = KII \text{ (Hz)} * 12.868$$

---

## Velocity loop

The following recommendations for IDNs 100 and 101 should typically give adequate servo performance. However, it may be necessary to do further optimization for some mechanical loads.

### IDN 100

Velocity Loop Proportional Gain (KVP). This IDN should be set so that:

$$\text{KVP (amps/rad/sec)} = 2\pi * f_{vc} \text{ (Hz)} * J_{\text{total}} / K_{\text{teff}} \text{ (rad/sec}^2\text{/amp)}$$

$$\text{IDN 100} = \text{KVP (Amps/rad/sec)} / (I_{\text{peak}} * 193.38\text{e-6})$$

where:

$J_{\text{total}}$  = Load inertia reflected to the motor shaft + motor inertia (lb-in-s<sup>2</sup>)

$f_{vc}$  = velocity loop bandwidth (Hz)

$K_{\text{teff}}$  = torque constant (effective)

### IDN 101

Velocity Loop Integral Gain (KVI). This IDN should be set so that:

$$\text{KVI} = f_{vc} \text{ (Hz)} / 15$$

$$\text{IDN 101} = \text{KVI (Hz)} * 51.4719$$

---

## Position loop

**IDN 104** Position Loop Proportional Gain (KPP). This IDN should be set according to table below. Gain settings are determined by the response type: Gentle, Medium, or Stiff.

Response	$f_{vc}$	IDN 101 (KVI)	IDN 32843 (ARF0)	IDN 32844 (ARF1)	IDN 104 (KPP)
Gentle	25	172	10000	20000	2056
Medium	75	515	15000	75000	6167
Stiff	250	1716	150000	10,000,000	20556

IDN 104 = KPP (Hz) / 2.4324e-3 (for Resolver Feedback - IDN 32824 = 0)

IDN 104 = 4 \* KPP (Hz) / 2.4324e-3 (for Encoder Feedback - IDN 32824 = 1 or 2)

**Note:** *Kpp sets the position loop bandwidth for all values of RemoteFB (IDN 32824).*

**IDN 32840** Kvff sets the proportion of velocity feed forward signal added to the velocity command from differentiated position command. This IDN should be set so that:

IDN 32840 = Kvff (%) \* 10

**Note:** Increasing Kvff reduces steady state following error (position loop null error proportional to speed) and gives faster response time. However, if Kvff is too large, it will provide overshoot. Typically Kvff should not be set larger than 80 for smooth dynamics and acceptable overshoot, but should be set to 100 for minimum following error, which may be necessary in some applications.

---

## 5.2 Motor Commutation

---

**IDN 32807** Number of motor magnetic poles (Polecount), which is the same as twice the number of motor electrical cycles per mechanical revolution. This IDN should be set so that:

For resolver based commutation (IDN 32853 = 0):

IDN 32807 (PoleCount) = Number of motor poles

For encoder based commutation (IDN 32853 = 1):

IDN 32807 (PoleCount) = Number of encoder counts / electrical cycle.

$IDN\ 32807 = 4 * IDN\ 32828 / (\text{Motor poles} / 2)$

**Note:** For encoder based commutation, it is required to do an encoder alignment using IDN 32854.

### Example

If the application uses resolver based commutation with an R-Series motor, set IDN 32807 = 4 (R-Series motors have 4 poles).

If the application uses resolver based commutation with an S-Series motor, set IDN 32807 = 6 (S-Series motors have 6 poles).

If the application uses encoder based commutation with an R-Series motor and an 1024 line count encoder, set IDN 32807 =  $4 * 1024 / (4/2) = 2048$ .

**Note:** CommSrc (IDN 32853) must be set before PoleCount (IDN 32807).

**IDN 32826** CommOff sets the origin for the electrical commutation angle. This IDN should be set so that for Pacific Scientific motors:

IDN 32826 (CommmOff) = 0

---

## 5.3 System protection

---

**Current Limits** To protect the motor and drive, set the ILmts to:

**IDN 82** Clockwise Current Limit (IlmtPlus). This IDN should be set so that:

$$\text{IlmtPlus} = \min(100\%, 100\% * 5 * I_{CS}/I_{\text{Peak}})$$

where  $I_{CS}$  is the motor's rms terminal current rating

$$\text{IDN 82} = \% \text{ of } I_{\text{Peak}} * 10$$

(i.e. for a 9x3 IlmtPlus of 50% or 7.5A set IDN 82 to 500)

**IDN 83** Counter-Clockwise Current Limit (IlmtMinus). This IDN should be set so that:

$$\text{IlmtMinus} = \min(100\%, 100\% * 5 * I_{CS}/I_{\text{Peak}})$$

where  $I_{CS}$  is the motor's rms terminal current rating

$$\text{IDN 83} = \% \text{ of } I_{\text{Peak}} * 10$$

(i.e. for a 9x3 IlmtMinus of 50% or 7.5A set IDN 83 to 500)

**Note:** *Application requirements may constrain the ILmts even further.*

---

**IDN 32829**

ItThresh sets the maximum continuous output current, as a percentage of Ipeak, before the I\*T thermal protection faults the drive. This IDN should be set so that:

$$\text{IDN 32829 (ItThresh)} = \min(60\%, 100\% * 3 * I_{MTR\text{continuous}} / I_{PR})$$

---

**Ipeak**

The following tables list the peak current rating for each of the drives in the SC900, Millennium, and Bautz families.

<b>Pacific Scientific Model</b>	<b>Ipeak (Amps)</b>
9X2	7.5
9X3	15.0
9X4	30.0
9X5	60.0

<b>Millenium Model</b>	<b>Ipeak (Amps)</b>
MX3	55.0
MX4	110.0
MX5	194.0
MX6	291.0
MX7	581.0

<b>Bautz Model</b>	<b>Ipeak (Amps)</b>
SCE9X3	10.6
SCE9X4	21.2

---

**Anti-resonance Filters**

Two digital anti-resonance filters, ARF0 (IDN 32843) and ARF1 (IDN 32844) are included in the velocity loop. These filters attenuate the velocity loop gain at the mechanical resonant frequency.

ARZ0 (IDN 32841) and ARZ1 (IDN 32842) are generally not needed and should be set to zero, which eliminates them entirely. However, for advanced compensation, ARZ0 or ARZ1 can be used to add lead compensation or used together to add a notch filter.

ARZ0 positive sets the zero frequency in Hz. If ARZ0 is less than zero, ARZ0 sets the under damped zero pair frequency in Hz and ARZ1 sets the under damped pair Q.

---

**IDN 32841**

First velocity loop compensation zero. This IDN should typically be set to  $ARZ0 \text{ (Hz/100)} = 0$ .

The units of ARZ0 are 0.01 Hz.

**IDN 32842**

Second velocity loop compensation zero. This IDN should typically be set to  $ARZ1 \text{ (Hz/100)} = 0$ .

The units of ARZ1 are 0.01 Hz.



---

**IDN 32843**

First velocity loop compensation anti-resonance low-pass filter corner frequency. This IDN should be set so that:

$$\begin{aligned} \text{IDN 32843} &= \text{ARF0 (Hz)} * 100 \\ &= 10000 \text{ for Gentle Response,} \\ &= 15000 \text{ for Medium Response,} \\ &\text{and} = 150000 \text{ for Stiff Response} \end{aligned}$$

**IDN 32844**

Second velocity loop compensation anti-resonance low-pass filter corner frequency. This IDN should be set so that:

$$\begin{aligned} \text{IDN 32844} &= \text{ARF1 (Hz)} * 100 \\ &= 20000 \text{ for Gentle Response,} \\ &= 75000 \text{ for Medium Response,} \\ &\text{and} = 10000000 \text{ for Stiff Response} \end{aligned}$$

---

**Low-pass filters**

For each of the following filters, the scale factor is 1 and the lower the break frequency (Hz) the more the signal is averaged and smoothed out and the slower the response will be to a signal change.

**IDN 32809**

First-order low-pass filter corner frequency for the analog input channel on J4-1,2 (ADF0). This IDN should be set so that:

$$\text{IDN 32809 (ADF0)} = \text{Break Frequency of Analog Input Filter in Hz}$$

---

**IDN 32810**

Sets the corner frequency in Hz of a single pole low-pass filter on the DAC Monitor 1 output (J4-3) (DM1F0). This IDN should be set so that:

IDN 32810 (DM1F0) = Break frequency of DacMap1 Output  
Filter in Hz

**IDN 32811**

Sets the frequency in Hz of a single pole low-pass filter on the DAC Monitor 2 output (J4-4) (DM2F0). This IDN should be set so that:

IDN 32811 (DM2F0) = Break frequency of DacMap2 Output  
Filter in Hz

## 5.4 Advanced Velocity Loop Tuning

**Continuous time transfer function approximation** The transfer function for the velocity loop compensation block is given below:

$$\frac{FVelErr}{VelErr}(s) = \frac{\left(\frac{s}{\omega_z}\right)^2 + \frac{1}{Q_z} \frac{s}{\omega_z} + 1}{\left(\frac{s}{\omega_p}\right)^2 + \frac{1}{Q_p} \frac{s}{\omega_p} + 1}$$

$$\frac{ICmd}{VelErr}(s) = \frac{\left(\frac{s}{\omega_z}\right)^2 + \frac{1}{Q_z} \frac{s}{\omega_z} + 1}{\left(\frac{s}{\omega_p}\right)^2 + \frac{1}{Q_p} \frac{s}{\omega_p} + 1} (KVP) \left(1 + \frac{2\pi(KVI)}{s}\right)$$

For  $ARx0 > 0$ :

$$\omega_x = 2\pi\sqrt{(ARx0)(ARx1)}$$

$$Q_x = \frac{\sqrt{(ARx0)(ARx1)}}{ARx0 + ARx1}$$

For  $ARx0 < 0$ :

$$\omega_x = -2\pi ARx0$$

$$Q_x = ARx1$$

**Note:** When  $ARZ0$  and  $ARZ1$  are both zero, the numerator of  $\frac{FVelErr}{VelErr}(s)$  reduces to 1.

---

**Discrete time  
transfer  
function**

This transfer function is actually implemented as a digital discrete time system function on the DSP. The continuous time transfer function is converted to the discrete time domain by a backward Euler mapping:

$$s \rightarrow \frac{1}{T_s} (1 - z^{-1})$$

where  $T_s = 250 \mu\text{sec}$

# SC900 Velocity Control Block diagram

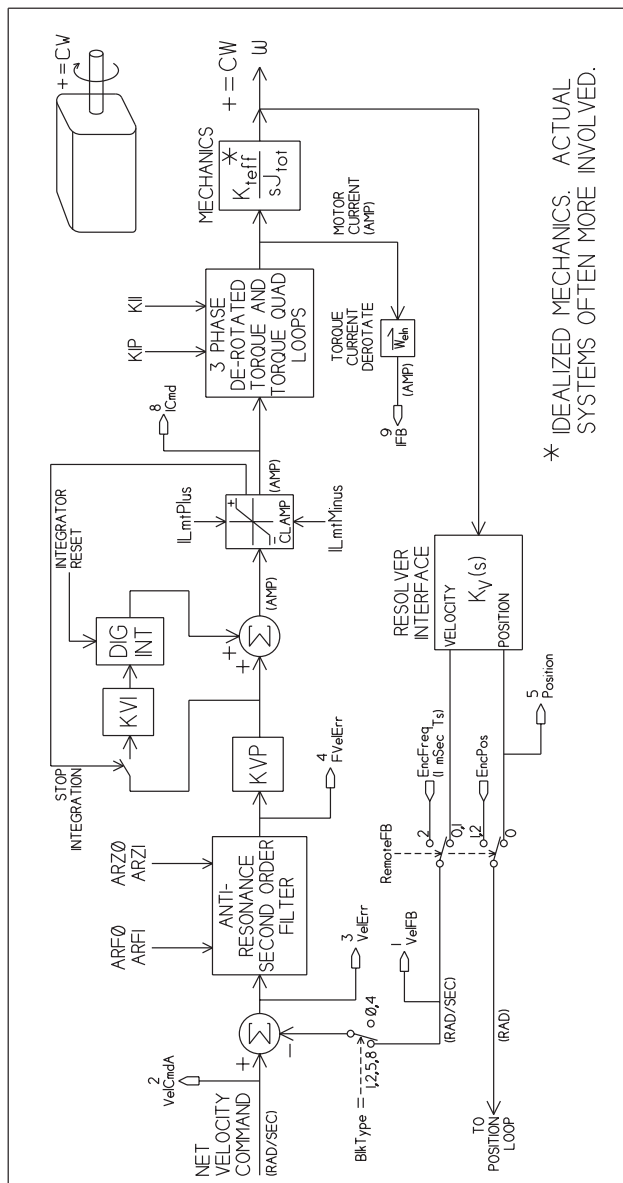

\* IDEALIZED MECHANICS - ACTUAL SYSTEMS OFTEN MORE INVOLVED.

---

## Section 6 - IDN Attributes

---

**Introduction** This section contains a list of Identification Numbers (IDNs) in numerical order.

### 6.1 SERCOS Specific Parameters

---

**IDN 1: Control unit cycle time** Parameter Data IDN  
Unsigned Decimal Number

Sercos Cycle Rate. This is the update rate for AT and MDT IDNs. This value must be at least 1000 (1 mSec) for Velocity mode, and 2000 (2 mSec) for Position mode operation. The maximum value is 64000 (64 mSec).

<b>Conversion Scaling Factor:</b>	1
<b>Data Length:</b>	2 bytes
<b>Units:</b>	$\mu s$
<b>Minimum Value:</b>	01000
<b>Maximum Value:</b>	64000
<b>Master Read (Phase 2):</b>	Always reads 0xFA00 - 64 mSec - Current value.
<b>Master Read (Phase 3 or 4):</b>	Value written to this drive while in Phase 2.
<b>Master Write:</b>	This IDN can only be written in Phase 2.

**IDN 2: Communication cycle time** Parameter Data IDN  
Unsigned Decimal Number

This value must be the same as IDN 1 - Control unit cycle time.

<b>Conversion Scaling Factor:</b>	1
<b>Data Length:</b>	2 bytes
<b>Units:</b>	$\mu s$
<b>Minimum Value</b>	01000
<b>Maximum Value</b>	64000

---

**IDN 3: Shortest AT Transmission starting time**

Parameter Data IDN

Unsigned Decimal Number

Time required by the OC940 after the MST before it is able to send the AT.

<b>Conversion Scaling Factor:</b>	1
<b>Data Length:</b>	2 bytes
<b>Units:</b>	$\mu s$
<b>Minimum Value:</b>	20
<b>Maximum Value:</b>	20
<b>Access State:</b>	Read Only by the Master.

**IDN 4: Transmit/receive transition time**

Parameter Data IDN

Unsigned Decimal Number

Time required by the OC940 after the end of transmitting the AT before it is ready to receive the MDT from the master.

<b>Conversion Scaling Factor:</b>	1
<b>Data Length:</b>	2 bytes
<b>Units:</b>	$\mu s$
<b>Minimum Value:</b>	20
<b>Maximum Value:</b>	20
<b>Access State:</b>	Read Only by the Master.

---

**IDN 5: Minimum feedback processing time**

Parameter Data IDN

Unsigned Decimal Number

Time required by the OC940 to acquire and compile the AT data prior to the MST.

<b>Conversion Scaling Factor:</b>	1
<b>Data Length:</b>	2 bytes
<b>Units:</b>	$\mu s$
<b>Minimum Value:</b>	300
<b>Maximum Value:</b>	300
<b>Access State:</b>	Read Only by the Master.

**IDN 6: AT transmission starting time**

Parameter Data IDN

Unsigned Decimal Number

The time the OC940 sends the AT after the end of the MST, as measured in  $\mu$ Sec. This value is calculated and written by the Master during Phase 2. The value read back is always the current value.

<b>Conversion Scaling Factor:</b>	1
<b>Data Length:</b>	2 bytes
<b>Units:</b>	$\mu s$
<b>Minimum Value:</b>	20
<b>Maximum Value:</b>	64000
<b>Access State:</b>	Read/Write in Phase 2. Read Only in Phase 3 and 4.



---

**IDN 7: Feedback acquisition capture point**

Parameter Data IDN

Unsigned Decimal Number

The OC940 shall acquire the AT data at this time. This value is calculated and written by the master during phase 2. The value read back is always the current value.

<b>Conversion Scaling Factor:</b>	1
<b>Data Length:</b>	2 bytes
<b>Units:</b>	$\mu s$
<b>Minimum Value:</b>	0
<b>Maximum Value:</b>	63700
<b>Access State:</b>	Read/Write in Phase 2. Read Only in Phase 3 and 4.

**IDN 8: Command value valid time**

Parameter Data IDN

Unsigned Decimal Number

At this moment of time, the OC940 shall begin using the data received from the master in the MDT. This value is calculated and written by the master during phase 2.

<b>Conversion Scaling Factor:</b>	1
<b>Data Length:</b>	2 bytes
<b>Units:</b>	$\mu s$
<b>Minimum Value:</b>	0
<b>Maximum Value:</b>	64000
<b>Access State:</b>	Read/Write in Phase 2. Read Only in Phase 3 and 4.

---

**IDN 9: Position of data record in MDT**

Parameter Data IDN

Unsigned Decimal Number

Position within the MDT that the drive's data begins. This value is in bytes and must be an odd value. This value is calculated and written by the master during phase 2.

<b>Conversion Scaling Factor:</b>	1
<b>Data Length:</b>	2 bytes
<b>Minimum Value:</b>	0
<b>Maximum Value:</b>	65531
<b>Access State:</b>	Read/Write in Phase 2. Read Only in Phase 3 and 4.

**IDN 10: Length of MDT**

Parameter Data IDN

Unsigned Decimal Number

The length of the MDT in bytes. This includes data records for all drives. This value is calculated and written by the master during phase 2.

<b>Conversion Scaling Factor:</b>	1
<b>Data Length:</b>	2 bytes
<b>Minimum Value:</b>	4
<b>Maximum Value:</b>	65534
<b>Access State:</b>	Read/Write in Phase 2. Read Only in Phase 3 and 4.

---

**IDN 11: Class 1 diagnostic**

Parameter Data IDN

Binary Data

This IDN reports back the status of the motor/drive. All faults reported in this IDN cause the OC940 to disable the drive. Clearing the fault is required before the motor can be enabled. The OC940 supports the following bits in this IDN:

<b>Bit Number</b>	<b>Description</b>
Bit 0	IT Fault
Bit 1	Controller Overtemperature Fault
Bit 2	Motor Overtemperature Fault
Bit 4	Controller Power Stage Fault
Bit 5	Resolver Overspeed Fault
Bit 6	Commutation Fault
Bit 7	Bus Over Current Fault
Bit 8	Bus Over Voltage Fault
Bit 9	Bus Under Voltage Fault
Bit 11	Excess Position Deviation Fault
Bit 12	Communication Error Fault
Bit 15	Manufacturer Specific Fault

**Conversion Scaling Factor:** 1  
**Data Length:** 2 bytes  
**Minimum Value:** 0  
**Maximum Value:** 0xFFFF  
**Access State:** Read Only by the Master.

---

**IDN 14: Interface status**

Parameter Data IDN

Binary Data

This IDN reports back the Communication Interface Status. All faults reported in this IDN cause the OC940 to disable the drive and place the SERCOS protocol back into Phase 0. The Communication Error Fault in IDN 11 is also set. Clearing the fault is required before the motor can be enabled. The OC940 supports the following bits in this IDN:

Bit Number	Description
Bits 0-2	Phase - Indicates either phase of fault or current phase.
Bit 3	MST Failure - Missed 2 Consecutive MSTs while in Phase 4.
Bit 4	MDT Failure - Missed 2 Consecutive MDTs while in Phase 4.
Bit 5	Invalid Phase - Improper Phase Change
Bit 6	Error Up
Bit 7	Error Down
Bit 8	Phase WO ACK

**Conversion Scaling Factor:** 1  
**Data Length:** 2 bytes  
**Minimum Value:** 0  
**Maximum Value:** 0xFFFF  
**Access State:** Read Only by the Master.

---

**IDN 15: Telegram type parameter**

Parameter Data IDN

Binary Data

This IDN indicates which set of IDNs are to be supported in the AT and MDT.

The OC940 supports the following parameter configurations (0 - 7 inclusive):

**Configuration 0** : No AT or MDT IDNs.

**Configuration 4** : IDN 47 (Position Command) in the MDT  
IDN 51 (Position Feedback) in the AT.

**Configuration 7** : User defined AT and MDT. Refer to IDNs 16 and 24.

**Conversion Scaling Factor:** 1  
**Data Length:** 2 bytes  
**Minimum Value:** 0  
**Maximum Value:** 7  
**Access State:** Read/Write in Phase 2.  
Read Only in Phase 3 and 4.

**IDN 16: Configuration list of AT**

Parameter Data IDN

IDN ID Number List

List of IDNs which are to be included in a User Defined AT. The data contained in this list is governed by the following restrictions:

Each IDN must be included in the list of Valid AT IDNs (Refer to IDN 187).

Total number of AT IDNs must be 8 or less.

Total number of bytes transferred must be 20 or less.

This IDN must be written when IDN 15 = 7. (Custom Telegram)

**Conversion Scaling Factor:** 1  
**Data Length:** 2 Bytes data - Variable Length  
**Access State:** Read/Write in Phase 2.  
Read Only in Phase 3 and 4.

---

**IDN 17: IDN list of all operation data**

Parameter Data IDN

IDN ID Number List

The Master receives a list of valid IDNs when this IDN is read.

**Conversion Scaling Factor:** 1

**Data Length:** 2 Bytes data - Variable Length

**Access State:** Read Only by the Master.

**IDN 18: IDN list of operation data for CP2**

Parameter Data IDN

IDN ID Number List

List of required operational data which must be received by the OC940 before a change to phase 3 can proceed.

**Note:** *A valid waveshape must exist prior to phase 3. The OC940 has a default value which allows access into phase 3. Partially overwriting the waveshape will prevent access into CP3.*

**Conversion Scaling Factor:** 1

**Data Length:** 2 Bytes data - Variable Length

**Access State:** Read Only by the Master.

**IDN 19: IDN list of operation data for CP3**

Parameter Data IDN

IDN ID Number List

List of required operational data which must be received by the OC940 before a change to phase 4 can proceed.

**Conversion Scaling Factor:** 1

**Data Length:** 2 Bytes data - Variable Length

**Access State:** Read Only by the Master.

---

**IDN 21: IDN list of invalid operation data for CP2** Parameter Data IDN  
IDN ID Number List

List of required operational data which has not been received by the OC940 before a change in phase to phase 3 can proceed.

**Conversion Scaling Factor:** 1  
**Data Length:** 2 Bytes data - Variable Length  
**Access State:** Read Only by the Master.

**IDN 22: IDN list of invalid operation data for CP3** Parameter Data IDN  
IDN ID Number List

List of required operational data which has not been received by the OC940 before a change in phase to phase 4 can proceed.

**Conversion Scaling Factor:** 1  
**Data Length:** 2 Bytes data - Variable Length  
**Access State:** Read Only by the Master.

**IDN 24: Configuration list of MDT** Parameter Data IDN  
IDN ID Number List

List of IDNs which are to be included in a User Defined MDT. The data contained in this list is governed by the following restrictions:

Each IDN must be included in the list of Valid MDT IDNs (Refer to IDN 188).

Total number of MDT IDNs must be 8 or less.

Total number of bytes transferred must be 20 or less.

This IDN must be written when IDN 15 = 7. (Custom Telegram)

**Conversion Scaling Factor:** 1  
**Data Length:** 2 Bytes data - Variable Length  
**Access State:** Read/Write in Phase 2.  
Read Only in Phase 3 and 4.

---

**IDN 25: IDN list of all procedure commands**

Parameter Data IDN

IDN ID Number List

List of all COMMAND IDNs (Reset Fault, Home, etc.) supported by the OC940.

**Conversion Scaling Factor:** 1

**Data Length:** 2 Bytes data - Variable Length

**Access State:** Read Only by the Master.

**IDN 28: MST Error Counter**

Parameter Data IDN

Unsigned Decimal Number

**Conversion Scaling Factor:** 1

**Data Length:** 2 bytes

**Minimum Value:** 0

**Maximum Value:** 65535

**Access State:** Read Only by the Master.

**IDN 29: MDT Error Counter**

Parameter Data IDN

Unsigned Decimal Number

**Conversion Scaling Factor:** 1

**Data Length:** 2 bytes

**Minimum Value:** 0

**Maximum Value:** 65535

**Access State:** Read Only by the Master.



---

**IDN 32: Primary operation mode**

Parameter Data IDN

Binary Data

The mode of operation is sent by the Master to the OC940 during Phase 2 with this IDN. Valid modes of operation are velocity, position and torque mode.

**Mode 1: Torque Mode** - Allows the use of IDN 80 (Torque Command) over the Service Channel to control torque of drive.

**Mode 2 : Velocity Mode** - Allows use of IDN 36 (Velocity Command) over the Service Channel to control speed of drive.

**Mode 3 : Position Mode** - Allows use of IDN 47 (Position Command) over the Cyclic and Service Channel to control position of drive.

**Conversion Scaling Factor:** 1  
**Data Length:** 2 bytes  
**Minimum Value:** 1  
**Maximum Value:** 3  
**Access State:** Read/Write in Phase 2.  
Read Only in Phase 3 and 4.

**IDN 36: Velocity command value**

Parameter Data IDN

Signed Decimal Number

Gives access to the instantaneous Velocity Command value of the OC940.

**Conversion Scaling Factor:** 1  
**Data Length:** 4 bytes  
**Units** Motor velocity (RPM) /  $[(\text{IDN } 45) \cdot 10^{(\text{IDN } 46)}]$   
**Minimum Value:** -2,147,483,647  
**Maximum Value:** 2,147,483,647  
**Master Read:** Reads the instantaneous Velocity Command from the OC940.

---

**IDN 36 continued**

**Master Write:** **Position Mode:** Always overwritten by newVelocity Command generated from the Position Command.  
**Velocity Mode:** Sets the Velocity Command of the OC940.

**Access State:** Read/Write in phases 2-4.

**IDN 40: Velocity feedback value** Parameter Data IDN  
Signed Decimal Number

Gives access to the instantaneous Velocity Feedback value of the OC940.

**Conversion Scaling Factor:** 1  
**Data Length:** 4 bytes  
**Units** Motor velocity (RPM) / [(IDN 45)\*10^(IDN 46)]  
**Minimum Value:** -2,147,483,647  
**Maximum Value:** 2,147,483,647  
**Master Read:** Reads the instantaneous Velocity Feedback from the OC940.

**IDN 41: Homing velocity** Parameter Data IDN  
Signed Decimal Number

Sets the maximum velocity a home command is processed at.

**Note:** *\*\*\*Home velocity not affected by FEEDRATE OVERRIDE\*\*\**

**Note:** *No motion will occur if the following is true: -1024 < value of IDN 41 < 1024.*

**Conversion Scaling Factor:** 1  
**Data Length:** 4 bytes  
**Units** Motor velocity (RPM) / [(IDN 45)\*10^(IDN 46)]  
**Minimum Value:** -2,147,483,647  
**Maximum Value:** 2,147,483,647  
**Access State:** Read/Write in phases 2-4.

---

**IDN 42: Homing acceleration**

Parameter Data IDN

Unsigned Decimal Number

Sets the maximum acceleration a home command is processed at.

**Conversion Scaling Factor :** 1  
**Data Length :** 4 bytes  
**Units:** IDN 41/2 msec  
**Minimum Value:** 1  
**Maximum Value:** 4,294,967,295  
**Access State:** Read/Write in phases 2-4.

**IDN 43: Velocity polarity parameter**

Parameter Data IDN

Binary Data

Defines the polarity of the velocity data (IDNs 36 and 40).

<b>Bit Number</b>	<b>Bit Setting</b> (1 = Inverted, 0 = Non-Inverted)
Bit 0	Controls Velocity Command Data
Bit 1	Must be zero
Bit 2	Controls Velocity Feedback Data
Bits 3 - 15	Reserved and must be zero.

**Conversion Scaling Factor:** 1  
**Data Length:** 2 bytes  
**Minimum Value:** 1  
**Maximum Value:** 7  
**Access State:** Read/Write in phases 2-4.

---

**IDN 44: Velocity data scaling type**

Parameter Data IDN

Binary Data

Defines the scaling type for the OC940. For the OC940, IDN 44 = 0xA

Bit Number	Bit Setting
Bits 0-2	010 : Rotational Scaling
Bit 3	1 : Parameter Scaling
Bit 4	0 : Revolutions
Bit 5	0 : Minutes
Bit 6	0 : At the Motor Shaft

**Conversion Scaling Factor:** 1  
**Data Length:** 2 bytes  
**Minimum Value:** 0xA  
**Maximum Value:** 0xA  
**Access State:** Read Only by the Master.

**IDN 45: Velocity data scaling factor**

Parameter Data IDN

Unsigned Decimal Number

All velocity data (IDNs 36, 40 and 41) are scaled by the following formula:  
(IDN 45)\*10^(IDN 46). IDN 45 = 44775.

**Conversion Scaling Factor:** 1  
**Data Length:** 2 bytes  
**Minimum Value:** 44775  
**Maximum Value:** 44775  
**Access State:** Read Only by the Master.

---

**IDN 46: Velocity data scaling exponent**

Parameter Data IDN

Signed Decimal Number

All velocity data (IDNs 36, 40 and 41) are scaled using the following formula:  
(IDN 45)\*10^(IDN 46). IDN 46 = -8

<b>Conversion Scaling Factor:</b>	1
<b>Data Length:</b>	2 bytes
<b>Minimum Value:</b>	-8
<b>Maximum Value:</b>	-8
<b>Access State:</b>	Read Only by the Master.

**IDN 47: Position command value**

Parameter Data IDN

Signed Decimal Number

Allows the Master to have access to the instantaneous Position Command value of the OC940 drive.

<b>Conversion Scaling Factor:</b>	1
<b>Data Length:</b>	4 bytes
<b>Units:</b>	resolver or encoder counts (depending on feedback device used)
<b>Minimum Value:</b>	-2,147,483,647
<b>Maximum Value:</b>	2,147,483,647
<b>Master Read:</b>	Reads the instantaneous Position Command Value.
<b>Master Write:</b>	Sets the instantaneous Position Command Value. This value will be overwritten by the Position Feedback Data when the drive is not enabled. This value sent over the Service Channel will be overwritten by any applicable cyclic channel data.
<b>Access State:</b>	Read/Write in phases 2-4.

---

**IDN 51: Position feedback value 1**

Parameter Data IDN

Signed Decimal Number

Allows the Master to have access to the instantaneous Position Feedback value of the OC940 drive.

<b>Conversion Scaling Factor:</b>	1
<b>Data Length:</b>	4 bytes
<b>Units:</b>	resolver or encoder counts (depending on feedback device used)
<b>Minimum Value:</b>	-2,147,483,647
<b>Maximum Value:</b>	2,147,483,647
<b>Master Read:</b>	Reads the instantaneous Position Command Value.

**IDN 52: Reference distance 1**

Parameter Data IDN

Signed Decimal Number

Programmable Position offset used during Home Commands.

<b>Conversion Scaling Factor:</b>	1
<b>Data Length:</b>	4 bytes
<b>Units:</b>	resolver or encoder counts (depending on feedback device used)
<b>Minimum Value:</b>	-2,147,483,647
<b>Maximum Value:</b>	2,147,483,647
<b>Access State:</b>	Read/Write in phases 2-4.

---

**IDN 55: Position polarity parameter**

Parameter Data IDN

Binary Data

Defines the Position Polarity Parameters.

<b>Bit Number</b>	<b>Bit Setting</b> (1 = Inverted, 0 = Non-Inverted)
Bit 0	Position Command Data (IDN 47).
Bit 1	Must be zero.
Bit 2	Position Feedback Data (IDN 51).
Bit 3	Must be zero.
Bit 4	Must be zero.

**Conversion Scaling Factor:** 1  
**Data Length:** 2 bytes  
**Minimum Value:** 0  
**Maximum Value:** 5  
**Access State:** Read in phases 2-4.  
Write in phase 2.

---

**IDN 76: Position data scaling type**

Parameter Data IDN

Binary Data

Defines the position scaling type for the OC940.

Bit Number	Bit Setting
Bits 0-2	010 : Rotational Scaling.
Bit 3	1 : Parameter Scaling.
Bit 4	0 : Degrees.
Bit 5	0 : Reserved.
Bit 6	0 : At the Motor Shaft.
Bit 7	0/1 : 0 => Absolute Format. 1 => Modulo format (IDN 103).

**Note:** Only Bit 7 may be changed by the Master while in phase 2. All other bits are Read Only, trying to change them results in a Service Channel error.

**Conversion Scaling Factor:** 1  
**Data Length:** 2 bytes  
**Minimum Value:** 0x0A  
**Maximum Value:** 0x8A  
**Access State:** Read Only in phase 4.



---

**IDN 77: Linear position data scaling factor**

Parameter Data IDN

Unsigned Decimal Number

All position data (IDNs 47, 51, 130, 131, 132 and 133) is scaled according to the formula  $(IDN\ 77) \cdot 10^{(IDN\ 78)}$ . For the OC940, IDN 77 = 65536.

<b>Conversion Scaling Factor:</b>	1
<b>Data Length:</b>	2 bytes
<b>Minimum Value:</b>	1
<b>Maximum Value:</b>	65535
<b>Access State:</b>	Read Only by the Master.

**IDN 78: Linear position data scaling exponent**

Parameter Data IDN

Signed Decimal Number

All position data (IDNs 47, 51, 130, 131, 132 and 133) is scaled according to the formula  $(IDN\ 77) \cdot 10^{(IDN\ 78)}$ . For the OC940, IDN 78 = 0.

<b>Conversion Scaling Factor:</b>	1
<b>Data Length:</b>	2 bytes
<b>Minimum Value:</b>	-32,767
<b>Maximum Value:</b>	32,767
<b>Access State:</b>	Read Only by the Master.

---

**IDN 79: Rotational position resolution**

Parameter Data IDN

Unsigned Decimal Number

All position data has the following resolution: 0x10000 (65536 counts/rev)

<b>Conversion Scaling Factor:</b>	1
<b>Data Length:</b>	4 bytes
<b>Units:</b>	percent
<b>Minimum Value:</b>	65536
<b>Maximum Value:</b>	65536
<b>Access State:</b>	Read Only by the Master.

**IDN 80: Torque command value**

Parameter Data IDN

Signed Decimal Number

Gives access to the instantaneous torque value of the OC940.

<b>Conversion Scaling Factor:</b>	0.009 Amps ( 1000 = 9 Amps)
<b>Data Length:</b>	2 bytes
<b>Minimum Value:</b>	-32767
<b>Maximum Value:</b>	32767
<b>Master Read:</b>	Reads the instantaneous current command of the OC940.
<b>Master Write:</b>	<b>Position and Velocity Mode:</b> Always overwritten by new current command generated by the velocity loop.
	<b>Torque Mode:</b> Sets the current command of the OC940.
<b>Access State:</b>	Read/Write in phases 2-4.

---

**IDN 82: Positive torque limit value**

Parameter Data IDN

Unsigned Decimal Number

Value of IlmtPlus corresponds to the clockwise direction of the motor and is set in 0.1% increments. Value is truncated to % increments.

<b>Conversion Scaling Factor:</b>	1
<b>Data Length:</b>	2 bytes
<b>Units:</b>	0.1 percent
<b>Minimum Value:</b>	0
<b>Maximum Value:</b>	1000
<b>Access State:</b>	Read/Write by the Master in phases 2-4.

**IDN 83: Negative torque limit value**

Parameter Data IDN

Unsigned Decimal Number

Value of IlmtMinus corresponds to the counter-clockwise direction of the motor is set in 0.1% increments. Value is truncated to % increments.

<b>Conversion Scaling Factor:</b>	1
<b>Data Length:</b>	2 bytes
<b>Units:</b>	0.1 percent
<b>Minimum Value:</b>	0
<b>Maximum Value:</b>	1000
<b>Access State:</b>	Read/Write by the Master in phases 2-4.

---

**IDN 84: Torque feedback value**

Parameter Data IDN

Signed Decimal Number

Gives access to the instantaneous Torque Feedback Value of the OC940.

**Conversion Scaling Factor:** 0.009 Amps (1000 = 9 Amps)**Data Length:** 2 bytes**Minimum Value:** -32767**Maximum Value:** 32767**Access State:** Read Only by the Master.**IDN 85: Torque polarity parameter**

Parameter Data IDN

Binary Data

Defines the Torque Polarity Parameters.

<b>Bit Number</b>	<b>Bit Setting</b> (1 = Inverted, 0 = Non-Inverted)
Bit 0	Torque command value
Bit 1	Additive Torque command value - Must be zero
Bit 2	Torque feedback value
Bits 3-15	Reserved and must be zero

**Conversion Scaling Factor:** 1**Data Length:** 2 bytes**Minimum Value:** 0**Maximum Value:** 5**Access State:** Read/Write in phase 2.  
Read Only by the Master in Phases 3-4.

---

**IDN 88: Receive to receive recovery time**

Parameter Data IDN

Unsigned Decimal Number

Required time for the OC940 between the end of the MDT and the beginning of the next MST.

<b>Conversion Scaling Factor:</b>	1
<b>Data Length:</b>	2 bytes
<b>Units:</b>	$\mu s$
<b>Minimum Value:</b>	350
<b>Maximum Value:</b>	350
<b>Access State:</b>	Read Only by the Master.

**IDN 89: MDT transmission starting time**

Parameter Data IDN

Unsigned Decimal Number

Value sent by the Master to indicate the starting time in uSec of the MDT. This value is calculated and written by the master during phase 2.

<b>Conversion Scaling Factor:</b>	1
<b>Data Length:</b>	2 bytes
<b>Units:</b>	$\mu s$
<b>Minimum Value:</b>	1
<b>Maximum Value:</b>	64000
<b>Access State:</b>	Read/Write by the Master.

---

**IDN 90: Command value proceeding time**

Parameter Data IDN

Binary Data

Value read by the Master indicating how soon after the MDT the OC940 can make the received data available for usage.

<b>Conversion Scaling Factor:</b>	1
<b>Data Length:</b>	2 bytes
<b>Units:</b>	$\mu s$
<b>Minimum Value:</b>	1
<b>Maximum Value:</b>	0xFA00
<b>Access State:</b>	Read Only by the Master.

**IDN 95: Diagnostic message**

Parameter Data IDN

Text Data String

No diagnostic messages are available for this product at this time.

<b>Conversion Scaling Factor:</b>	1
<b>Data Length:</b>	1 Byte data - Variable Length
<b>Access State:</b>	Read Only by the Master.

**IDN 96: Slave Arrangement 0**

Parameter Data IDN

Binary Data

The OC940 returns its axis address in both the low and high byte of this IDN. The OC940 is not capable of supporting multiple motors on a single drive. Valid axis addresses range from 0x1 to 0xFE (1 - 254 decimal).

<b>Conversion Scaling Factor:</b>	1
<b>Data Length:</b>	2 bytes
<b>Minimum Value:</b>	0x101
<b>Maximum Value:</b>	0x101
<b>Access State:</b>	Read Only by the Master.

---

**IDN 99: Reset class 1 diagnostic**

Command Data IDN

Binary Data

Command Procedure IDN : Used to clear recorded faults in the OC940. Faults which cause the OC940 to cycle back to phase 0 are recorded and saved for transmission in phase 2. The OC940 will automatically notify the Master upon completion of this Command IDN. While this Command IDN is being performed, other service channel IDNs may be processed. Write 3 to IDN 99 to initiate Reset Class 1 Diagnostics (this will reset the fault and disable the drive). Write 0 to IDN 99 to de-activate the fault reset command. The drive cannot be enabled while fault reset is asserted.

<b>Conversion Scaling Factor:</b>	1
<b>Data Length:</b>	2 bytes
<b>Minimum Value:</b>	0
<b>Maximum Value:</b>	3
<b>Access State:</b>	Read/Write by the Master in phases 2-4.

**IDN 100: Velocity loop proportional gain**

Parameter Data IDN

Unsigned Decimal Number

Allows the master to set the value of kvp (Amp/rad/sec).  
 $IDN\ 100 = kvp / (I_{peak} * 193.38e-6)$ .

<b>Conversion Scaling Factor:</b>	1
<b>Data Length:</b>	2 bytes
<b>Minimum Value:</b>	0
<b>Maximum Value:</b>	65535
<b>Access State:</b>	Read/Write by the Master in phases 2-4.

---

**IDN 101: Velocity loop integral gain**

Parameter Data IDN

Unsigned Decimal Number

Allows the master to set the value of kvi (Hz).  $IDN\ 101 = kvi * 51.4719$ .

<b>Conversion Scaling Factor:</b>	1
<b>Data Length:</b>	2 bytes
<b>Minimum Value:</b>	1
<b>Maximum Value:</b>	65535
<b>Access State:</b>	Read/Write by the Master in phases 2-4.

**IDN 103: Modulo value**

Parameter Data IDN

Unsigned Decimal Number

Allows the master to set the Modulo value (IDN 76).

<b>Conversion Scaling Factor:</b>	1
<b>Data Length:</b>	4 bytes
<b>Minimum Value:</b>	10
<b>Maximum Value:</b>	2,147,483,647
<b>Access State:</b>	Read/Write in phase 2. Read Only in phases 3 and 4.



---

**IDN 104: Position loop Kp-factor**

Parameter Data IDN

Unsigned Decimal Number

Allows the master to set the value of kpp (Hz).  
IDN 104 =  $kpp / 2.4324e-3$  (for resolver feedback).  
IDN 104 =  $4 * kpp / 2.4324e-3$  (for encoder feedback).

**Conversion Scaling Factor:** 1  
**Data Length:** 2 bytes  
**Minimum Value:** 0  
**Maximum Value:** 65535  
**Access State:** Read/Write by the Master in phases 2-4.

**IDN 106: Current Loop Proportional Gain 1**

Parameter Data IDN

Unsigned Decimal Number

Allows the master to set the value of kip (Volts/Ampere).  
IDN 106 =  $kip * I_{peak} * 405.6685e-3$ .

**Conversion Scaling Factor:** 1  
**Data Length:** 2 bytes  
**Minimum Value:** 0  
**Maximum Value:** 65535  
**Access State:** Read/Write by the Master in phases 2-4.

---

**IDN 107: Current Loop Integral Action Time 1**

Parameter Data IDN

Unsigned Decimal Number

Allows the master to set the value of  $k_{ii}$  (Hz).  $IDN\ 107 = k_{ii} * 12.868$ .

<b>Conversion Scaling Factor:</b>	1
<b>Data Length:</b>	2 bytes
<b>Minimum Value:</b>	0
<b>Maximum Value:</b>	65535
<b>Access State:</b>	Read/Write by the Master in phases 2-4.

**IDN 108: Feedrate override**

Parameter Data IDN

Unsigned Decimal Number

Always at 100%.

<b>Conversion Scaling Factor:</b>	1
<b>Data Length:</b>	2 bytes
<b>Units:</b>	0.01%
<b>Minimum Value:</b>	10000
<b>Maximum Value:</b>	10000
<b>Access State:</b>	Read Only by the Master.

---

**IDN 110: Amplifier peak current**

Parameter Data IDN  
Unsigned Decimal Number

Contains the amplifier peak current.

**Conversion Scaling Factor:** 1  
**Data Length:** 4 bytes  
**Units:** mA  
**Minimum Value:** 0  
**Maximum Value:** 4,294,967,295  
**Access State:** Read Only by the Master.

**IDN 123: Feed constant**

Parameter Data IDN  
Binary Data

Always set to 0x10000

**Conversion Scaling Factor:** 1  
**Data Length:** 4 bytes  
**Minimum Value:** 0x10000  
**Maximum Value:** 0x10000  
**Access State:** Read Only by the Master.

---

**IDN 127:** Command Data IDN

**Communication phase 3 transition check** Binary Data

Command Procedure IDN used to check whether the OC940 is ready to proceed into phase 3. This IDN must be performed and successfully completed prior to going into phase 3. If all IDNs identified in IDN 18 have not been completed, or if the waveshape is incomplete, or if this IDN is not performed and the Master goes to phase 3, the OC940 will declare a fault and go to phase 0.

**Conversion Scaling Factor:** 1  
**Data Length:** 2 bytes  
**Minimum Value:** 0  
**Maximum Value:** 3  
**Access State:** Read/Write by the Master in phase 2.

**IDN 128:** Command Data IDN

**Communication phase 4 transition check** Binary Data

Command Procedure IDN used to check whether the OC940 is ready to proceed into phase 4. This IDN must be performed and successfully completed prior to going into phase 4. If not all IDNs identified in IDN 19 have not been completed or if this IDN is not performed and the Master goes to phase 4, the OC940 will declare a fault and go to phase 0.

**Conversion Scaling Factor:** 1  
**Data Length:** 2 bytes  
**Minimum Value:** 0  
**Maximum Value:** 3  
**Access State:** Read/Write by the Master in phase 3.

---

**IDN 129: Manufacturer Class 1 Diagnostic**

Parameter Data IDN

Binary Data

The data in this IDN contains the current manufacturer specific fault code. If the manufacturer fault bit is set in IDN 11, reading this IDN will return the current fault code. If no fault is present in the OC940, this value will be zero.

The low byte of the data is the Fault Code. This is the fault code which is displayed on the OC940 drive.

The high byte of the data is the Extended Fault Code. If the fault code has an associated extended fault code, it will be displayed here. Most fault codes do not have extended fault codes.

A '0' will be displayed for non faulted, not enabled drive.

An '8' will be displayed for non faulted, enabled drive.

<b>Fault Type</b>	<b>Fault Code</b>	<b>Extended Fault Code</b>
Resolver Overspeed	1	
Motor Overtemp	2	
Controller Overtemp	3	
Current-Time Fault	4	
Bus Over Current Fault	5	
Controller Under Volt	6	
Output Over Current	7	
Shunt Current Time	8	
Bus Over Voltage	0xA	
User 5 Volt	0xb	
Non-Volatile Cal Table	0xE	01
Excessive Current Sensor Offset	0xE	02

Table (cont'd)

<b>Fault Type</b>	<b>Fault Code</b>	<b>Extended Fault Code</b>
Processor Reset Fault	0xE	03
Soft (Lost/Unknown) Fault	0xE	04
Unknown Fault	0xE	05
Excessive Analog Input Offset	0xE	06
Invalid Option Card	0xE	07
Stack Overflow	0xE	08
Controller Revision Wrong	0xE	09
ASIC Revision Wrong	0xE	0xA
Wrong Power Stage	0xE	0xB
Unknown Power Stage	0xE	0xC
Controller EEPROM Checksum	0xE	0xD
Extended Ram Fault	0xE	0xF
Cal Table Ram Fault	0xE	0x10
Dual Port Ram Fault	0xE	0x11
Bus Under Voltage	0xE1	
Controller Under Temp	0xE2	
Encoder Comm Fault	0xE3	
EEPROM Version Fault	0xE4	
Incompatible HW	0xE5	
Unconfigured	0xE6	
Position Error Overflow	0xF1	

---

Table (cont'd)

<b>Fault Type</b>	<b>Fault Code</b>	<b>Extended Fault Code</b>
Prom Memory Fault	0xF3	
DSP - OC940 Comm Fault in AT	0xF5	0x01
DSP - OC940 Comm Fault in MDT	0xF5	0x02

**Conversion Scaling Factor:** 1  
**Data Length:** 2 bytes  
**Minimum Value:** 0  
**Maximum Value:** 0x0F05

**IDN 130: Probe value 1 positive edge**

Parameter Data IDN  
Signed Decimal Number

Returns the position value latched by the SC940 drive when a rising edge of the Probe 1 signal has occurred. The position is either in resolver or encoder counts depending on the feedback device used to close the position loop.

**Conversion Scaling Factor:** 1  
**Data Length:** 4 bytes  
**Minimum Value:** -2,147,483,647  
**Maximum Value:** 2,147,483,647  
**Access State:** Read Only by the Master.

---

**IDN 131: Probe value 1 negative edge**

Parameter Data IDN

Signed Decimal Number

Returns the position value latched by the SC940 drive when a falling edge of the Probe 1 signal has occurred. The position is either in resolver or encoder counts depending on the feedback device used to close the position loop.

**Conversion Scaling Factor:** 1  
**Data Length:** 4 bytes  
**Minimum Value:** -2,147,483,647  
**Maximum Value:** 2,147,483,647  
**Access State:** Read Only by the Master.

**IDN 132: Probe value 2 positive edge**

Parameter Data IDN

Signed Decimal Number

Returns the position value latched by the SC940 drive when a rising edge of the Probe 2 signal has occurred. The position is either in resolver or encoder counts depending on the feedback device used to close the position loop.

**Conversion Scaling Factor:** 1  
**Data Length:** 4 bytes  
**Minimum Value:** -2,147,483,647  
**Maximum Value:** 2,147,483,647  
**Access State:** Read Only by the Master.



---

**IDN 133: Probe value 2 negative edge**

Parameter Data IDN

Signed Decimal Number

Returns the position value latched by the SC940 drive when a falling edge of the Probe 2 signal has occurred. The position is either in resolver or encoder counts depending on the feedback device used to close the position loop.

<b>Conversion Scaling Factor:</b>	1
<b>Data Length:</b>	4 bytes
<b>Minimum Value:</b>	2,147,483,647
<b>Maximum Value:</b>	2,147,483,647
<b>Access State:</b>	Read Only by the Master.

**IDN 138: Bipolar acceleration limit value**

Parameter Data IDN

Unsigned Decimal Number

Acceleration value which the Master may read and write. Not used by the OC940.

<b>Conversion Scaling Factor:</b>	1
<b>Data Length:</b>	4 bytes
<b>Minimum Value:</b>	0
<b>Maximum Value:</b>	4,294,967,295

**IDN 140: Controller Type**

Parameter Data IDN

Text Data String

Allows the Master to read a TEXT description of the drive model number.

<b>Conversion Scaling Factor:</b>	1
<b>Data Length:</b>	1 Byte data - Variable length

---

**IDN 143: SYSTEM Interface Version**

Parameter Data IDN

Text Data String

Allows the Master to read a TEXT description of the SERCOS specification which the OC940 was designed to : V01.02

**Conversion Scaling Factor:** 1**Data Length:** 1 Byte data - Variable length**IDN 147: Homing parameter**

Parameter Data IDN

Binary Data

Defines the HOME parameters used by the OC940.

Bit Number	Bit Setting
Bit 0: Home Direction	0 => Positive/Clockwise Direction 1 => Negative/Counter Clockwise Direction
Bit 1: Position Feedback Marker Pulse	0 => First Marker Pulse after Positive Edge of Home Switch 1 => First Marker Pulse after Negative Edge of Home Switch
Bit 2: Home Switch : Connected to Drive	Must be 1.
Bit 3: Homing : Using Motor Feedback	Must be 0.
Bit 4: Interpretation in the drive : Homing Enable Only	Must be 1.
Bit 5: Evaluation of Home Switch	0 => Home Switch evaluated 1 => Home Switch not evaluated.
Bit 6: Evaluation of Position Feedback Marker Pulse	0 => Marker Pulse evaluated 1 => Marker Pulse not evaluated.

**Note:** Only Bits 0, 1, 5 and 6 may be changed by the Master while in phases 2-4. All other bits are Read Only, trying to change them results in a Service Channel error.

**Note:** Writing 0x77 to IDN 147 makes the current motor position the home (zero) position.

---

**IDN 147 (continued)**

<b>Conversion Scaling Factor:</b>	1
<b>Data Length:</b>	2 bytes
<b>Minimum Value:</b>	4
<b>Maximum Value:</b>	0x77

**IDN 148: Drive controlled homing procedure**

Command Data IDN

Binary Data

Command Procedure IDN used to initiate a Home event on the OC940. During the Home event, all velocity and position data received from the Master is ignored with the exception of Home Velocity (IDN 41) and Home Acceleration (IDN 42). Once the drive has finished the HOME event, the Position Feedback Value Status will be set (IDN 403). The Master must read the new position at this time and begin sending updated Position Commands prior to finishing this Command IDN to avoid Excessive Position Error Faults.

**Note:** *To execute homing more than once, reset IDN 148 by writing 0 and then 3.*

<b>Conversion Scaling Factor:</b>	1
<b>Data Length:</b>	2 bytes
<b>Minimum Value:</b>	0 (deactivate drive controlled homing)
<b>Maximum Value:</b>	3 (activate drive controlled homing)
<b>Access State:</b>	Read/Write by the Master in phases 2-4.

---

**IDN 159: Monitoring Window 0**

Parameter Data IDN

Unsigned Decimal Number

Sets the Maximum Position Deviation allowed by the OC940.

**Conversion Scaling Factor:** 16  
**Data Length:** 2 bytes  
**Minimum Value:** 0  
**Maximum Value:** 65535  
**Access State:** Read/Write by Master in phases 2-4.

**IDN 160: Acceleration data scaling type**

Parameter Data IDN

Binary Data

Defines the scaling type for the OC940.

Bit Number	Bit Setting
Bits 0-2	010 : Rotational Scaling
Bit 3	1 : Parameter Scaling
Bit 4	0 : Radian
Bit 5	0 : Seconds
Bit 6	0 : At the motor shaft.

**Conversion Scaling Factor:** 1  
**Data Length:** 2 bytes  
**Minimum Value:** 0x0A  
**Maximum Value:** 0x0A  
**Access State:** Read Only by the Master.

---

**IDN 161: Acceleration data scaling factor**

Parameter Data IDN  
Unsigned Decimal Number

All acceleration data is scaled by this value: 1875.

**Conversion Scaling Factor:** 1  
**Data Length:** 2 bytes  
**Minimum Value:** 1  
**Maximum Value:** 65535  
**Access State:** Read Only by the Master.

**IDN 162: Acceleration data scaling exponent**

Parameter Data IDN  
Signed Decimal Number

All acceleration data scaling is done with this exponent : -4.

**Conversion Scaling Factor:** 1  
**Data Length:** 2 bytes  
**Minimum Value:** -32767  
**Maximum Value:** 32767  
**Access State:** Read Only by the Master.

---

**IDN 169: Probe control parameter**

Parameter Data IDN

Binary Data

Defines the PROBE parameters used by the OC940. Please refer to Chapter 2 for additional information.

<b>Bit Number</b>	<b>Bit Setting</b>
Bit 0: Probe 1 Positive Edge	0 => Positive edge is not active. 1 => Positive edge is active.
Bit 1: Probe 1 Negative Edge	0 => Negative edge is not active. 1 => Negative edge is active.
Bit 2: Probe 2 Positive Edge	0 => Positive edge is not active. 1 => Positive edge is active.
Bit 3: Probe 2 Negative Edge	0 => Negative edge is not active. 1 => Negative edge is active.

**Conversion Scaling Factor:** 1**Data Length:** 2 bytes**Minimum Value:** 0**Maximum Value:** 0x0F

---

**IDN 170: Probing cycle procedure command**

Command Data IDN

Binary Data

Command Procedure IDN used to initiate PROBE events on the OC940. While this IDN is active, all probe events described in IDN 169, and enabled by IDN 405 and 406 are allowed to be recorded. This command must be activated in order for PROBE events to occur. Please refer to Chapter 2 for additional information.

**Note:** *To activate probing, write 3 to IDN 170.*

<b>Conversion Scaling Factor:</b>	1
<b>Data Length:</b>	2 bytes
<b>Minimum Value:</b>	0
<b>Maximum Value:</b>	3
<b>Access State:</b>	Read/Write by the Master in phases 2-4.

**IDN 185:**

Parameter Data IDN

**Length of the configurable data record in the AT** Unsigned Decimal Number

Maximum number of bytes allowed in the AT as configurable data is 20 bytes.

<b>Conversion Scaling Factor:</b>	1
<b>Data Length:</b>	2 bytes
<b>Minimum Value:</b>	0
<b>Maximum Value:</b>	65535
<b>Access State:</b>	Read Only by the Master.

---

**IDN 186:**

Parameter Data IDN

**Length of the configurable data record in the MDT**    Unsigned Decimal Number

Maximum number of bytes allowed in the MDT as configurable data is 20 bytes.

**Conversion Scaling Factor:**        1

**Data Length:**                        2 bytes

**Minimum Value:**                     0

**Maximum Value:**                    65535

**Access State:**                        Read Only by the Master.



---

**IDN 187:**

Parameter Data IDN

**IDN list of the configurable data in the AT**

IDN ID Number List

List of IDNs available for entry into the AT configuration list.

<b>IDN</b>	<b>IDN Description</b>
11	Class 1 Diagnostic Register
14	Interface Status
28	MST Error Count
29	MDT Error Count
40	Velocity Feedback
51	Position Feedback
85	Torque Feedback
129	Manufacturer Class 1 Diagnostic
130	Probe Value 1 Positive Edge
131	Probe Value 1 Negative Edge
132	Probe Value 2 Positive Edge
133	Probe Value 2 Negative Edge
34824	OC940 Input Byte
34825	Analog Input
34826	Encoder Position
34855	BDIO Input Byte

**Conversion Scaling Factor:** 1**Data Length:** 2 Bytes data - Variable Length**Access State:** Read Only by the Master.

---

**IDN 188:**

Parameter Data IDN

**IDN list of the configurable data record in the MDT**

IDN ID Number List

List of IDNs available for entry into the MDT configuration list.

<b>IDN</b>	<b>IDN Description</b>
36	Velocity Command
47	Position Command
80	Torque Command
34840	OC940 Output Byte
34841	DacMap 1 Voltage Output
34842	DacMap 2 Voltage Output
34863	BDIO Output Port

**Conversion Scaling Factor:** 1**Data Length:** 2 Bytes data - Variable Length**Access State:** Read Only by the Master.**IDN 189: Following Distance**

Parameter Data IDN

Signed Decimal Number

Allows the Master to read the current instantaneous Position Error.

**Conversion Scaling Factor:** 1**Data Length:** 4 bytes**Minimum Value:** -2,147,483,647**Maximum Value:** 2,147,483,647**Access State:** Read Only by the Master.

---

**IDN 301: Allocation of real-time control bit 1**

Parameter Data IDN

Unsigned Decimal Number

The Master sends the number of an IDN whose data is a BIT variable. This BIT variable is then sent in the MDT cyclic Real Time Control Bit 1 data. Please refer to Chapter 2 for additional information.

The IDNs which can be used for Real Time Control bits are:

<b>IDN</b>	<b>IDN Description</b>	<b>IDN</b>	<b>IDN Description</b>
405	Probe 1 Enable	34838	OC940 Output Bit #6
406	Probe 2 Enable	34839	OC940 Output Bit #7
34832	OC940 Output Bit #0	34857	BDIO Output Pin #1
34833	OC940 Output Bit #1	34858	BDIO Output Pin #2
34834	OC940 Output Bit #2	34859	BDIO Output Pin #3
34835	OC940 Output Bit #3	34860	BDIO Output Pin #4
34836	OC940 Output Bit #4	34861	BDIO Output Pin #5
34837	OC940 Output Bit #5	34862	BDIO Output Pin #6

**Conversion Scaling Factor:** 1

**Data Length:** 2 bytes

**Minimum Value:** 0 (Off)

**Maximum Value:** 65535

**Access State:** Read/Write by Master in phases 2-4.

---

**IDN 303: Allocation of real-time control bit 2**

Parameter Data IDN

Unsigned Decimal Number

The Master sends the number of an IDN whose data is a BIT variable. This BIT variable is then sent in the MDT cyclic Real Time Control Bit 2 data. Please refer to Chapter 2 for additional information.

The IDNs which can be used for Real Time Control bits are:

<b>IDN</b>	<b>IDN Description</b>	<b>IDN</b>	<b>IDN Description</b>
405	Probe 1 Enable	34838	OC940 Output Bit #6
406	Probe 2 Enable	34839	OC940 Output Bit #7
34832	OC940 Output Bit #0	34857	BDIO Output Pin #1
34833	OC940 Output Bit #1	34858	BDIO Output Pin #2
34834	OC940 Output Bit #2	34859	BDIO Output Pin #3
34835	OC940 Output Bit #3	34860	BDIO Output Pin #4
34836	OC940 Output Bit #4	34861	BDIO Output Pin #5
34837	OC940 Output Bit #5	34862	BDIO Output Pin #6

**Conversion Scaling Factor:** 1

**Data Length:** 2 bytes

**Minimum Value:** 0 (Off)

**Maximum Value:** 65535

**Access State:** Read/Write by Master in phases 2-4.

---

**IDN 305: Allocation of real-time status bit 1**

Parameter Data IDN

Unsigned Decimal Number

The Master sends the number of an IDN whose data is a BIT variable. This BIT variable is then sent in the AT cyclic Real Time Status Bit 1 data. Please refer to Chapter 2 for additional information.

The IDNs which can be used for Real Time Status bits are:

<b>IDN</b>	<b>IDN Description</b>	<b>IDN</b>	<b>IDN Description</b>
400	Home Switch	34819	OC940 Input Bit #3
401	Probe 1	34820	OC940 Input Bit #4
402	Probe 2	34821	OC940 Input Bit #5
403	Position Feedback Value Status	34822	OC940 Input Bit #6
409	Probe 1 Positive Latched	34823	OC940 Input Bit #7
410	Probe 1 Negative Latched	34849	BDIO Input Pin #1
411	Probe 2 Positive Latched	34850	BDIO Input Pin #2
412	Probe 2 Negative Latched	34851	BDIO Input Pin #3
34816	OC940 Input Bit #0	34852	BDIO Input Pin #4
34817	OC940 Input Bit #1	34853	BDIO Input Pin #5
34818	OC940 Input Bit #2	34854	BDIO Input Pin #6

**Conversion Scaling Factor:** 1**Data Length:** 2 bytes**Minimum Value:** 0 (Off)**Maximum Value:** 65535**Access State:** Read/Write by Master in phases 2-4.

---

**IDN 307: Allocation of real-time status bit 2**

Parameter Data IDN

Unsigned Decimal Number

The Master sends the number of an IDN whose data is a BIT variable. This BIT variable is then sent in the AT cyclic Real Time Status Bit 2 data. Please refer to Chapter 2 for additional information.

The IDNs which can be used for Real Time Status bits are :

<b>IDN</b>	<b>IDN Description</b>	<b>IDN</b>	<b>IDN Description</b>
400	Home Switch	34819	OC940 Input Bit #3
401	Probe 1	34820	OC940 Input Bit #4
402	Probe 2	34821	OC940 Input Bit #5
403	Position Feedback Value Status	34822	OC940 Input Bit #6
409	Probe 1 Positive Latched	34823	OC940 Input Bit #7
410	Probe 1 Negative Latched	34849	BDIO Input Pin #1
411	Probe 2 Positive Latched	34850	BDIO Input Pin #2
412	Probe 2 Negative Latched	34851	BDIO Input Pin #3
34816	OC940 Input Bit #0	34852	BDIO Input Pin #4
34817	OC940 Input Bit #1	34853	BDIO Input Pin #5
34818	OC940 Input Bit #2	34854	BDIO Input Pin #6

**Conversion Scaling Factor:** 1**Data Length:** 2 bytes**Minimum Value:** 0 (Off)**Maximum Value:** 65535**Access State:** Read/Write by Master in phases 2-4.

---

**IDN 400: Home Switch**

Parameter Data IDN

Binary Data

Allows the Master to read the current state of the Home Switch. If more than one BDIO is defined to be the Home Switch, the highest BDIO (1-6) is the value returned.

<b>Conversion Scaling Factor:</b>	1
<b>Data Length:</b>	2 bytes
<b>Minimum Value:</b>	0
<b>Maximum Value:</b>	1
<b>Access State:</b>	Read Only by the Master.

**IDN 401: Probe 1**

Parameter Data IDN

Binary Data

Allows the Master to read the current state of the Probe 1 switch. The only BDIO pin which can be defined as Probe 1 is BDIO 4.

<b>Conversion Scaling Factor:</b>	1
<b>Data Length:</b>	2 bytes
<b>Minimum Value:</b>	0
<b>Maximum Value:</b>	1
<b>Access State:</b>	Read Only by the Master.

---

**IDN 402: Probe 2**

Parameter Data IDN

Binary Data

Allows the Master to read the current state of the Probe 2 switch. The only BDIO pin which can be defined as Probe 2 is BDIO 5.

<b>Conversion Scaling Factor:</b>	1
<b>Data Length:</b>	2 bytes
<b>Minimum Value:</b>	0
<b>Maximum Value:</b>	1
<b>Access State:</b>	Read Only by the Master.

**IDN 403: Position feedback value status**

Parameter Data IDN

Binary Data

This bit is set by the OC940 whenever a Home has been successfully completed.

This bit starts off CLEARED upon initialization.

<b>Conversion Scaling Factor:</b>	1
<b>Data Length:</b>	2 bytes
<b>Minimum Value:</b>	0
<b>Maximum Value:</b>	1
<b>Access State:</b>	Read Only by the Master.



---

**IDN 405: Probe 1 enable**

Parameter Data IDN

Binary Data

This bit must be set by the Master (either by Cyclic or Service Channel) in order for Probe 1 Data to be latched. IDN 169 must specify the valid Probe edges to latch and IDN 170 must also be active for Probe 1 data to be latched. Please refer to Chapter 2 for additional information.

<b>Conversion Scaling Factor:</b>	1
<b>Data Length:</b>	2 bytes
<b>Minimum Value:</b>	0
<b>Maximum Value:</b>	1
<b>Access State:</b>	Read/Write by Master.

**IDN 406: Probe 2 enable**

Parameter Data IDN

Binary Data

This bit must be set by the Master (either by Cyclic or Service Channel) in order for Probe 2 Data to be latched. IDN 169 must specify the valid Probe edges to latch and IDN 170 must also be active for Probe 2 data to be latched. Please refer to Chapter 2 for additional information.

<b>Conversion Scaling Factor:</b>	1
<b>Data Length:</b>	2 bytes
<b>Minimum Value:</b>	0
<b>Maximum Value:</b>	1
<b>Access State:</b>	Read/Write by Master.

---

**IDN 409: Probe 1 positive latched**

Parameter Data IDN

Binary Data

This bit is used to indicate that Probe 1 Positive Edge data has been latched by the OC940. Reading IDN 130 will return the Probe data for this event. Please refer to Chapter 2 for additional information.

<b>Conversion Scaling Factor:</b>	1
<b>Data Length:</b>	2 bytes
<b>Minimum Value:</b>	0
<b>Maximum Value:</b>	1
<b>Access State:</b>	Read Only by the Master.

**IDN 410: Probe 1 negative latched**

Parameter Data IDN

Binary Data

This bit is used to indicate that Probe 1 Negative Edge data has been latched by the OC940. Reading IDN 131 will return the Probe data for this event. Please refer to Chapter 2 for additional information.

<b>Conversion Scaling Factor:</b>	1
<b>Data Length:</b>	2 bytes
<b>Minimum Value:</b>	0
<b>Maximum Value:</b>	1
<b>Access State:</b>	Read Only by the Master.

---

**IDN 411: Probe 2 positive latched**

Parameter Data IDN

Binary Data

This bit is used to indicate that Probe 2 Positive Edge data has been latched by the OC940. Reading IDN 132 will return the Probe data for this event. Please refer to Chapter 2 for additional information.

<b>Conversion Scaling Factor:</b>	1
<b>Data Length:</b>	2 bytes
<b>Minimum Value:</b>	0
<b>Maximum Value:</b>	1
<b>Access State:</b>	Read Only by the Master.

**IDN 412: Probe 2 negative latched**

Parameter Data IDN

Binary Data

This bit is used to indicate that Probe 2 Positive Edge data has been latched by the OC940. Reading IDN 133 will return the Probe data for this event. Please refer to Chapter 2 for additional information.

<b>Conversion Scaling Factor:</b>	1
<b>Data Length:</b>	2 bytes
<b>Minimum Value:</b>	0
<b>Maximum Value:</b>	1
<b>Access State:</b>	Read Only by the Master.

---

## 6.2 Manufacturer Specific Parameters

---

### IDN 32800: DSP Debug Address

Parameter Data IDN

Binary Data

Used for Manufacturer Investigations. Master would write an address to access into this IDN.

<b>Conversion Scaling Factor:</b>	1
<b>Data Length:</b>	2 bytes
<b>Minimum Value:</b>	0
<b>Maximum Value:</b>	0xFFFF
<b>Access State:</b>	Read/Write by the Master.

### IDN 32801: DSP Debug Word

Parameter Data IDN

Binary Data

Used for Manufacturer Investigations. Reading this IDN causes the WORD data located in the address specified in IDN 32800 to be read.

<b>Conversion Scaling Factor:</b>	1
<b>Data Length:</b>	2 bytes
<b>Minimum Value:</b>	0
<b>Maximum Value:</b>	0xFFFF
<b>Access State:</b>	Read Only by the Master.

---

**IDN 32802: DSP Debug DWord**

Parameter Data IDN

Binary Data

Used for Manufacturer Investigations. Reading the IDN causes the DWORD data located in the address specified in IDN 32800 to be read.

**Conversion Scaling Factor:** 1  
**Data Length:** 4 bytes  
**Minimum Value:** 0  
**Maximum Value:** 0xFFFFFFFF  
**Access State:** Read Only by the Master.

**IDN 32803:**

Parameter Data IDN

**Pacific Scientific Defined - Do NOT Access**

Unsigned Decimal Number

Do NOT Access - For use by Pacific Scientific Personnel Only.

**Conversion Scaling Factor:** 1  
**Data Length:** 4 bytes  
**Minimum Value:** 0  
**Maximum Value:** 4,294,967,295  
**Access State:** Read/Write by Master.

**IDN 32804: Slave Tx Level**

Parameter Data IDN

Binary Data

Allows the Master to set the OC940 SERCOS Transmission Power Level.

**Conversion Scaling Factor:** 1  
**Data Length:** 2 bytes  
**Minimum Value:** 1  
**Maximum Value:** 0x3F  
**Access State:** Read/Write by Master.

---

**IDN 32805:** Parameter Data IDN  
**Pacific Scientific Defined - Do NOT Access** Binary Data  
Do NOT Access - For use by Pacific Scientific Personnel Only.  
**Conversion Scaling Factor:** 1  
**Data Length:** 2 bytes  
**Minimum Value:** 0  
**Maximum Value:** 0xffff  
**Access State:** Read/Write by the Master.

**IDN 32806:** Parameter Data IDN  
**Pacific Scientific Defined - Do NOT Access** Binary Data  
Do NOT Access - For use by Pacific Scientific Personnel Only.  
**Conversion Scaling Factor:** 1  
**Data Length:** 2 bytes  
**Minimum Value:** 0  
**Maximum Value:** 0xffff  
**Access State:** Read/Write by the Master.

---

**IDN 32807: Pole Count**

Parameter Data IDN

Unsigned Decimal Number

Number of motor poles used for motor commutation. For encoder based commutation:

$$\text{Polecount} = \frac{\text{Encoder counts / rev}}{(\text{motor poles} / 2)}$$

**Note:** IDN 32853 (CommSrc) must be set BEFORE IDN 32807. Please refer to Chapter 5 for additional information.

<b>Conversion Scaling Factor:</b>	1
<b>Data Length:</b>	2 bytes
<b>Units:</b>	motor poles
<b>Minimum Value:</b>	2
<b>Maximum Value:</b>	32766
<b>Access State:</b>	Read/Write by the Master in phase 2. Read/Write in phases 3 and 4.

**IDN 32808: PosErrorMax**

Parameter Data IDN

Unsigned Decimal Number

32 bit Jam detection threshold. If Position Error exceeds this number the drive initiates Jam Detection. Will result in a fault if Position Error remains above this number for a period of time. If this value is set higher than the Monitoring Window (IDN 159), this function will not occur.

<b>Conversion Scaling Factor:</b>	1
<b>Data Length:</b>	4 bytes
<b>Units:</b>	Resolver counts
<b>Minimum Value:</b>	0
<b>Maximum Value:</b>	4,294,967,295
<b>Access State:</b>	Read/Write by the Master.

---

**IDN 32809: Filter Value for ADF0**

Parameter Data IDN

Unsigned Decimal Number

Sets the filter break frequency for the Analog Input. Please refer to Chapter 3 for additional information.

<b>Conversion Scaling Factor:</b>	1
<b>Data Length:</b>	2 bytes
<b>Units:</b>	Hz
<b>Minimum Value:</b>	1
<b>Maximum Value:</b>	65535
<b>Access State:</b>	Read/Write by the Master.

**IDN 32810: DM1F0**

Parameter Data IDN

Unsigned Decimal Number

Sets the filter break frequency for DacMonitor 1. Please refer to Chapter 3 for additional information.

<b>Conversion Scaling Factor:</b>	1
<b>Data Length:</b>	2 bytes
<b>Units:</b>	Hz
<b>Minimum Value:</b>	1
<b>Maximum Value:</b>	65535
<b>Access State:</b>	Read/Write by the Master.



---

**IDN 32811: DM2F0**

Parameter Data IDN

Unsigned Decimal Number

Sets the filter break frequency for DacMonitor 2. Please refer to Chapter 3 for additional information.

<b>Conversion Scaling Factor:</b>	1
<b>Data Length:</b>	2 bytes
<b>Units:</b>	Hz
<b>Minimum Value:</b>	1
<b>Maximum Value:</b>	65535
<b>Access State:</b>	Read/Write by the Master.

**IDN 32812: DM1Gain**

Parameter Data IDN

Signed Decimal Number

Sets the analog output gain for DacMap 1. Scale factor depends on the setting of DacMap 1. Refer to Dac Monitor Map and Gain Units List. Please refer to Chapter 3 for additional information.

<b>Conversion Scaling Factor:</b>	1
<b>Data Length:</b>	4 bytes
<b>Minimum Value:</b>	-2,147,483,647
<b>Maximum Value:</b>	2,147,483,647
<b>Access State:</b>	Read/Write by the Master.

---

**IDN 32813: DM2Gain**

Parameter Data IDN

Signed Decimal Number

Sets the analog output gain for DacMap 2. Scale factor depends on the setting of DacMap 2. Refer to Dac Monitor Map and Gain Units List. Please refer to Chapter 3 for additional information.

<b>Conversion Scaling Factor:</b>	1
<b>Data Length:</b>	4 bytes
<b>Minimum Value:</b>	-2,147,483,647
<b>Maximum Value:</b>	2,147,483,647
<b>Access State:</b>	Read/Write by the Master.

**IDN 32814: DM1Map -Mux Select**

Parameter Data IDN

Unsigned Decimal Number

Refer to Dac Monitor Map and Gain Units List. Use the DMxMAP column for the desired function. Please refer to Chapter 3 for additional information.

<b>Conversion Scaling Factor:</b>	1
<b>Data Length:</b>	2 bytes
<b>Minimum Value:</b>	0
<b>Maximum Value:</b>	75
<b>Access State:</b>	Read/Write by the Master.

---

**IDN 32815: DM2Map -Mux Select**

Parameter Data IDN

Unsigned Decimal Number

Refer to Dac Monitor Map and Gain Units List. Use the DMxMAP column for the desired function. Please refer to Chapter 3 for additional information.

<b>Conversion Scaling Factor:</b>	1
<b>Data Length:</b>	2 bytes
<b>Minimum Value:</b>	0
<b>Maximum Value:</b>	75
<b>Access State:</b>	Read/Write by the Master.

**IDN 32816: EncOut**

Parameter Data IDN

Unsigned Decimal Number

Sets the line count of the emulated encoder. Writing 0 to this IDN internally connects the EncIn input pins to the EncOut output buffers.

125, 250, 500, 1000, 2000, 4000, 8000, 16000 lines/rev

128, 256, 512, 1024, 2048, 4096, 8192, 16384 lines/rev

**Note:** *The number of encoder counts per revolution is equal to 4 \* encoder line count.*

<b>Conversion Scaling Factor:</b>	1
<b>Data Length:</b>	4 bytes
<b>Units:</b>	Emulated encoder count
<b>Minimum Value:</b>	0
<b>Maximum Value:</b>	16384
<b>Access State:</b>	Read/Write by the Master.

---

**IDN 32817: BDIOMap1**

Parameter Data IDN

Binary Data

Refer to BDIO Map List, Function Number Column for the desired function.

Set Input/Output, High/Low Polarity bits as required. Please refer to Chapter 2 for additional information.

<b>Conversion Scaling Factor:</b>	1
<b>Data Length:</b>	4 bytes
<b>Minimum Value:</b>	0
<b>Maximum Value:</b>	0xffffffff
<b>Access State:</b>	Read/Write by the Master.

**IDN 32818: BDIOMap2**

Parameter Data IDN

Binary Data

Refer to BDIO Map List, Function Number Column for the desired function.

Set Input/Output, High/Low Polarity bits as required. Please refer to Chapter 2 for additional information.

<b>Conversion Scaling Factor:</b>	1
<b>Data Length:</b>	4 bytes
<b>Minimum Value:</b>	0
<b>Maximum Value:</b>	0xffffffff
<b>Access State:</b>	Read/Write by the Master.

---

**IDN 32819: BDIOMap3**

Parameter Data IDN

Binary Data

Refer to BDIO Map List, Function Number Column for the desired function.

Set Input/Output, High/Low Polarity bits as required. Please refer to Chapter 2 for additional information.

<b>Conversion Scaling Factor:</b>	1
<b>Data Length:</b>	4 bytes
<b>Minimum Value:</b>	0
<b>Maximum Value:</b>	0xffffffff
<b>Access State:</b>	Read/Write by the Master.

**IDN 32820: BDIOMap4**

Parameter Data IDN

Binary Data

Refer to BDIO Map List, Function Number Column for the desired function.

Set Input/Output, High/Low Polarity bits as required. Please refer to Chapter 2 for additional information.

<b>Conversion Scaling Factor:</b>	1
<b>Data Length:</b>	4 bytes
<b>Minimum Value:</b>	0
<b>Maximum Value:</b>	0xffffffff
<b>Access State:</b>	Read/Write by the Master.

---

**IDN 32821: BDIOMap5**

Parameter Data IDN

Binary Data

Refer to BDIO Map List, Function Number Column for the desired function.

Set Input/Output, High/Low Polarity bits as required. Please refer to Chapter 2 for additional information.

<b>Conversion Scaling Factor:</b>	1
<b>Data Length:</b>	4 bytes
<b>Minimum Value:</b>	0
<b>Maximum Value:</b>	0xffffffff
<b>Access State:</b>	Read/Write by the Master.

**IDN 32822: BDIOMap6**

Parameter Data IDN

Binary Data

Refer to BDIO Map List, Function Number Column for the desired function.

Set Input/Output, High/Low Polarity bits as required. Please refer to Chapter 2 for additional information.

<b>Conversion Scaling Factor:</b>	1
<b>Data Length:</b>	4 bytes
<b>Minimum Value:</b>	0
<b>Maximum Value:</b>	0xffffffff
<b>Access State:</b>	Read/Write by the Master.

---

**IDN 32823: EncInFilt**

Parameter Data IDN

Unsigned Decimal Number

Sets the break frequency of the input filters on the Encoder Input pins.

**Conversion Scaling Factor:** 1**Data Length:** 4 bytes**Units:** Hz**Minimum Value:** 0**Maximum Value:** 16000000**Access State:** Read/Write by Master.

EncMode	Scaling	Encoder Input Filter Setting			
		High	Medium	Low	Lowest
(0) Quadrature	Max Quadrature Freq.	1600000	800000	400000	200000
(1) StepDir	Max Step Freq	800000	200000	100000	50000
(2) Up/Down	Max Step Freq	800000	200000	100000	50000
(3) Hold Count	N/A	N/A	N/A	N/A	N/A

---

**IDN 32824: RemoteFB**

Parameter Data IDN

Unsigned Decimal Number

Determines the source of Velocity and Position Feedback

**Conversion Scaling Factor:** 1**Data Length:** 4 bytes**Minimum Value:** 0**Maximum Value:** 2**Access State:** Read/Write by Master in Phase 2.

<b>RemoteFB</b>	<b>Velocity Feedback</b>	<b>Position Feedback</b>
0	Resolver	Resolver
1	Resolver	Encoder
2	Encoder	Encoder

**IDN 32825: BDLgcThr**

Parameter Data IDN

Unsigned Decimal Number

Allows the logic threshold for the BDIO Inputs to be changed. Can be either TTL compatible (5 Volt Logic) or 24 Volt Logic compatible.

0 = 5 volt logic

1 = 24 volt logic

**Conversion Scaling Factor:** 1**Data Length:** 4 bytes**Minimum Value:** 0**Maximum Value:** 1**Access State:** Read/Write by Master.



---

**IDN 32826: CommOff**

Parameter Data IDN

Signed Decimal Number

Allows the commutation offset to be set. For Pacific Scientific motors this should be zero. For custom motors, this should be set for proper commutation.

**Note:** *Negative numbers will be returned as the positive equivalent angle (modulo 360).*

**Conversion Scaling Factor:** 1  
**Data Length:** 4 bytes  
**Units:** Electrical degrees  
**Minimum Value:** -360  
**Maximum Value:** 360  
**Access State:** Read/Write by Master.

**IDN 32827: EncMode**

Parameter Data IDN

Unsigned Decimal Number

EncMode specifies the type of digital command expected at the incremental position command port.

EncMode	Description
0	Selects quadrature encoder pulses
1	Selects step and direction input signals
2	Selects up/down input signals
3	Ignores input signal, EncPos value held

**Conversion Scaling Factor:** 1  
**Data Length:** 4 bytes  
**Minimum Value:** 0  
**Maximum Value:** 3  
**Access State:** Read/Write by Master.

---

**IDN 32828: EncIn**

Parameter Data IDN

Unsigned Decimal Number

Allows the line count of input encoder to be defined. Must be set when RemoteFB (IDN 32824) = 1 or 2.

<b>Conversion Scaling Factor:</b>	1
<b>Data Length:</b>	4 bytes
<b>Units:</b>	Encoder line count
<b>Minimum Value:</b>	1
<b>Maximum Value:</b>	65535
<b>Access State:</b>	Read/Write in phase 2 Read Only in phases 3 and 4.

**IDN 32829: ITThresh**

Parameter Data IDN

Unsigned Decimal Number

Allows the fault threshold for the IT Fault to be adjusted.

<b>Conversion Scaling Factor:</b>	1
<b>Data Length:</b>	4 bytes
<b>Units:</b>	percent
<b>Minimum Value:</b>	0
<b>Maximum Value:</b>	100
<b>Access State:</b>	Read/Write by Master.

<b>Pacific Scientific Model Family</b>	<b>Minimum Value</b>	<b>Maximum Value</b>
94X	0	60
Millennium M4X	0	100
Bautz SCE94X	0	55

---

**IDN 32830: StopTime**

Parameter Data IDN

Unsigned Decimal Number

The StopTime variable is associated with the RunStop BDIO Function. It determines the maximum time after RunStop transitions to Stop that it will take the drive to disable. This IDN corresponds to an obsolete function. Do not use.

<b>Conversion Scaling Factor:</b>	1
<b>Data Length:</b>	4 bytes
<b>Units:</b>	seconds
<b>Minimum Value:</b>	0
<b>Maximum Value:</b>	32
<b>Access State:</b>	Read/Write by Master.

**IDN 32831: VBusThresh**

Parameter Data IDN

Signed Decimal Number

Allows the Bus Undervoltage threshold to be set. If set to a negative number, turns off the bus undervoltage fault.

<b>Conversion Scaling Factor:</b>	1
<b>Data Length:</b>	4 bytes
<b>Units:</b>	Volts
<b>Minimum Value:</b>	-2
<b>Maximum Value:</b>	63998
<b>Access State:</b>	Read/Write by Master.

---

**IDN 32832: VelLmtHi**

Parameter Data IDN

Signed Decimal Number

Minimum value allowed for the velocity command into the velocity block. Also sets the overspeed fault threshold if  $|VelLmtHi| > |VelLmtLo|$ .

Overspeed fault set at  $1.5 * (\max(|VelLmtHi|, |VelLmtLo|))$

<b>Conversion Scaling Factor:</b>	1
<b>Data Length:</b>	4 bytes
<b>Units:</b>	RPM
<b>Minimum Value:</b>	-21038
<b>Maximum Value:</b>	21038
<b>Access State:</b>	Read/Write by Master.

**IDN 32833: VelLmtLo**

Parameter Data IDN

Signed Decimal Number

Minimum value allowed for the velocity command into the velocity block. Also sets the overspeed fault threshold if .

Overspeed fault set at

<b>Conversion Scaling Factor:</b>	1
<b>Data Length:</b>	4 bytes
<b>Units:</b>	RPM
<b>Minimum Value:</b>	-21038
<b>Maximum Value:</b>	21038
<b>Access State:</b>	Read/Write by Master.

---

**IDN 32834: IlmtMode**

Parameter Data IDN

Unsigned Decimal Number

**Pacific Scientific Defined - Do NOT Access**

Do NOT Access - For use by Pacific Scientific Personnel Only

**Conversion Scaling Factor:** 1  
**Data Length:** 4 bytes  
**Minimum Value:** 0  
**Maximum Value:** 1  
**Access State:** Read/Write by Master in phase 2  
Read Only in phases 3 and 4.

**IDN 32835: CoastTime**

Parameter Data IDN

Unsigned Decimal Number

Allows the amount of time the drive will coast for after the bus voltage drops below VBusThresh before generating undervoltage fault.

**Conversion Scaling Factor:** 1  
**Data Length:** 4 bytes  
**Units:** seconds  
**Minimum Value:** 0  
**Maximum Value:** 32  
**Access State:** Read/Write by Master.

---

**IDN 32836: CommEnbl**

Parameter Data IDN

Unsigned Decimal Number

Enables commutation of the motor current based on rotor position. When the drive powers up CommEnbl is set to 1. When CommEnbl is set to 0, the commutation angle of the current flowing in the motor windings is determined by the value of CommOff. When CommEnbl is set to 1, the commutation angle is determined by the sum of CommSrc feedback device electrical angle and the CommOff variable.

**Conversion Scaling Factor:** 1  
**Data Length:** 4 bytes  
**Minimum Value:** 0  
**Maximum Value:** 1  
**Access State:** Read/Write by Master.

**IDN 32837: Motor**

Parameter Data IDN

Binary Data

The Motor variable is a 32-bit long unsigned long integer which is used to identify the waveshape downloaded to the SC900 controller using IDN 32848. By convention the 4 ASCII character abbreviation of the motor name is converted to an integer and downloaded along with the waveshape. The default value of this variable should be 0x53494E45 = 'S' (0x53) : 'I' (0x49) : 'N' (0x4E) : 'E' (0x45). Please refer to Chapter 4 for additional information.

Used to assign a label to Wave Shape Generation Table created

**Conversion Scaling Factor:** 1  
**Data Length:** 4 bytes  
**Minimum Value:** 0  
**Maximum Value:** 0xFFFFFFFF  
**Access State:** Read/Write in Phase 2.  
Read Only in Phase 3 and 4.

---

**IDN 32840: Kvff**

Parameter Data IDN

Unsigned Decimal Number

Allows following error to be reduced when running at a constant speed. When the drive is commanded to run at a constant speed, kvff = 1000 will reduce the steady state following error to zero, but will cause overshoot. A value of 700 is typically used.

<b>Conversion Scaling Factor:</b>	1
<b>Data Length:</b>	2 bytes
<b>Units:</b>	0.1 percent
<b>Minimum Value:</b>	0
<b>Maximum Value:</b>	2000
<b>Access State:</b>	Read/Write by the Master.

**IDN 32841: ARZ0**

Parameter Data IDN

Signed Decimal Number

ARZ0 is the first velocity loop compensation zero. Please refer to Chapter 5 for additional information.

<b>Conversion Scaling Factor:</b>	1
<b>Data Length:</b>	4 bytes
<b>Units:</b>	Hz/100
<b>Minimum Value:</b>	-10000000
<b>Maximum Value:</b>	10000000
<b>Access State:</b>	Read/Write by the Master.

---

**IDN 32842: ARZ1**

Parameter Data IDN

Signed Decimal Number

ARZ0 is the second velocity loop compensation zero. Please refer to Chapter 5 for additional information.

<b>Conversion Scaling Factor:</b>	1
<b>Data Length:</b>	4 bytes
<b>Units:</b>	Hz/100
<b>Minimum Value:</b>	-10000000
<b>Maximum Value:</b>	10000000
<b>Access State:</b>	Read/Write by the Master.

**IDN 32843: ARF0**

Parameter Data IDN

Signed Decimal Number

ARF0 is the first velocity loop compensation anti-resonance low-pass filter corner frequency. Please refer to Chapter 5 for additional information.

<b>Conversion Scaling Factor:</b>	1
<b>Data Length:</b>	4 bytes
<b>Units:</b>	Hz/100
<b>Minimum Value:</b>	-10000000
<b>Maximum Value:</b>	10000000
<b>Access State:</b>	Read/Write by the Master.



---

**IDN 32844: ARF1**

Parameter Data IDN

Signed Decimal Number

ARF1 is the second velocity loop compensation anti-resonance low-pass filter corner frequency. Please refer to Chapter 5 for additional information.

<b>Conversion Scaling Factor:</b>	1
<b>Data Length:</b>	4 bytes
<b>Units:</b>	Hz/100
<b>Minimum Value:</b>	-10000000
<b>Maximum Value:</b>	10000000
<b>Access State:</b>	Read/Write by the Master.

**IDN 32845: Firmware Version**

Parameter Data IDN

Text

Displays the current versions of the firmware: 3.00, and the DSP: 3.00.

<b>Conversion Scaling Factor:</b>	1
<b>Data Length:</b>	Byte list
<b>Access State:</b>	Read Only by the Master.

---

**IDN 32846: Encoder Data Scaling Method**

Parameter Data IDN

Binary Data

Sets the working parameters for the Encoder Position.

**Conversion Scaling Factor:** 1  
**Data Length:** 2 bytes  
**Minimum Value:** 0x0A  
**Maximum Value:** 0x18A  
**Access State:** Read/Write in phase 2.  
Read Only in Phases 3 and 4.

<b>Bit Number</b>	<b>Bit Setting</b> (1 = Inverted, 0 = Non-Inverted)
Bits 0-2	010 : Rotational Scaling.
Bit 3	1 : Parameter Scaling
Bit 4	0 : Degrees
Bit 5	0 : Reserved
Bit 6	0 : At the Motor Shaft
Bit 7	0 : Absolute format 1 : Modulo format (IDN 32847)
Bit 8	0 : Non-Inverted Encoder Data 1 : Inverted Encoder Data

---

**IDN 32847: Encoder Modulo Value**

Parameter Data IDN

Unsigned Decimal Number

Allows the master to set the Encoder Modulo value (IDN 32846).

<b>Conversion Scaling Factor:</b>	1
<b>Data Length:</b>	4 bytes
<b>Minimum Value:</b>	10
<b>Maximum Value:</b>	2,147,483,647
<b>Access State:</b>	Read/Write in phase 2. Read Only in Phases 3 and 4.

**IDN 32848 : WaveShape Coefficient List IDN**

Parameter Data IDN

Hexadecimal Word List

The waveshape is defined by a set of 26 numbers which are the coefficients (A,B) of a Fourier series representation or the line-to-neutral motor voltage  $S[\text{Acos}(nQ) - \text{Bsin}(nQ)]$  for  $n = 1,2,4,5,7,8,10,11,13,14,16,17,19$ . The coefficients are represented as signed integers with scaling of 1/32768 bit (-1.0 = -32768). After this IDN is written, IDN 32837 (MOTOR) must be written in order for the waveshape table to be generated and the waveshape task to be complete. The waveshape task must be completed prior to movement into Phase 3. The OC940 has a completed default waveshape (SINE) after every ring reset. Please refer to Chapter 4 for additional information.

<b>Conversion Scaling Factor:</b>	1
<b>Data Length:</b>	2 Bytes - variable length list
<b>Access State:</b>	Read/Write in phase 2. Read Only in phases 3 and 4.

---

**IDN 32853 : CommSrc**

Parameter Data IDN

Unsigned Decimal

Selects between resolver or incremental encoder feedback for motor commutation.

**Note:** *CommSrc (IDN 32853) must be set BEFORE PoleCount (IDN 32807).*

<b>Conversion Scaling Factor:</b>	1
<b>Data Length:</b>	4 Bytes
<b>Minimum Value:</b>	0 = resolver
<b>Maximum Value:</b>	1 = encoder
<b>Access State:</b>	Read/Write in all phases.

**IDN 32854 : Align Encoder Commutation Command**

Command IDN

Binary

Allows the Master to initiate an Encoder Commutation Alignment. Can only be performed while in Phase 4. The drive will not enable if IDN 32853 (CommSrc) = 1 (Encoder) and this command has not be performed.

<b>Conversion Scaling Factor:</b>	1
<b>Data Length:</b>	2 Bytes
<b>Minimum Value:</b>	0
<b>Maximum Value:</b>	3
<b>Access State:</b>	Read Only in phases 2 and 3. Read/Write in phase 4.

---

**IDN 32855: NVSave**

Command Data IDN

Binary Data

The NVSave function copies the following IDNs to Non-Volatile (NV) memory: 15, 32, 41, 42, 55, 76, 82, 83, 100, 101, 103, 104, 106, 107, 140, 147, 159, 32807-32835, 32837, 32840-32844, 32848, 32853.

NVSave	Description
0	NVSave function is NOT performed. NVLoad (IDN 32856) is DISABLED.
1	Performs NVSave function. NVLoad (IDN 32856) is ENABLED.

**Conversion Scaling Factor:** 1**Data Length:** 2 bytes**Minimum Value:** 0**Maximum Value:** 1**Access State:** Read\Write by the Master in phases 2-4.**IDN 32856: NVLoad**

Command Data IDN

Binary Data

NVLoad loads saved IDNs from Non-Volatile (NV) memory to the drive's active memory, whenever the drive is powered on or is in phase 0. The master need not write to these IDNs as part of the drive initialization thereby substantially reducing the time required to bring the SERCOS ring to Phase 4.

**This function will only be executed if NVSave was executed.** NVLoad can also be executed by writing 1 to IDN 32856 (NVLoad) via the service-channel in phase 2.

**Note:** *Writing 0 to NVSave (IDN 32855) DISABLES NVLoad.*

---

**IDN 32856 (continued)**

**Conversion Scaling Factor:** 1  
**Data Length:** 2 bytes  
**Minimum Value:** 0  
**Maximum Value:** 1  
**Access State:** Read by the Master in phases 2-4.  
Write by the Master in phase 2 only.

**IDN 32857: Resolver Position**

Parameter Data IDN

Unsigned Decimal Number

ResPos returns the absolute resolver position within one revolution. The SC940 has 65536 resolver counts per revolution. This IDN will, therefore, return a value between 0 and 65535. This IDN is NOT affected by Position Modulo (IDN 103).

**Conversion Scaling Factor:** 1  
**Data Length:** 2 bytes  
**Minimum Value:** 0  
**Maximum Value:** 65535  
**Access State:** Read/Write by the Master in phases 2-4.

---

**IDN 34816: OC940 Input Bit #0**

Parameter Data IDN

Binary Data

Allows the Master to read the value of the Input Bit 0 located on J43-1 of the OC940 Board.

**Note:** *User must supply Input Power to have Input Circuitry to operate.*

<b>Conversion Scaling Factor:</b>	1
<b>Data Length:</b>	2 bytes
<b>Minimum Value:</b>	0
<b>Maximum Value:</b>	1
<b>Access State:</b>	Read Only by the Master.

**IDN 34817: OC940 Input Bit #1**

Parameter Data IDN

Binary Data

Allows the Master to read the value of the Input Bit 1 located on J43-2 of the OC940 Board.

**Note:** *User must supply Input Power to have Input Circuitry to operate.*

<b>Conversion Scaling Factor:</b>	1
<b>Data Length:</b>	2 bytes
<b>Minimum Value:</b>	0
<b>Maximum Value:</b>	1
<b>Access State:</b>	Read Only by the Master.

---

**IDN 34818: OC940 Input Bit #2**

Parameter Data IDN

Binary Data

Allows the Master to read the value of the Input Bit 2 located on J43-3 of the OC940 Board.

**Note:** *User must supply Input Power to have Input Circuitry to operate.*

**Conversion Scaling Factor:** 1  
**Data Length:** 2 bytes  
**Minimum Value:** 0  
**Maximum Value:** 1  
**Access State:** Read Only by the Master.

**IDN 34819: OC940 Input Bit #3**

Parameter Data IDN

Binary Data

Allows the Master to read the value of the Input Bit 3 located on J43-4 of the OC940 Board.

**Note:** *User must supply Input Power to have Input Circuitry to operate.*

**Conversion Scaling Factor:** 1  
**Data Length:** 2 bytes  
**Minimum Value:** 0  
**Maximum Value:** 1  
**Access State:** Read Only by the Master.



---

**DN 34820: OC940 Input Bit #4**

Parameter Data IDN

Binary Data

Allows the Master to read the value of the Input Bit 4 located on J43-5 of the OC940 Board.

**Note:** *User must supply Input Power to have Input Circuitry to operate.*

**Conversion Scaling Factor:** 1  
**Data Length:** 2 bytes  
**Minimum Value:** 0  
**Maximum Value:** 1  
**Access State:** Read Only by the Master.

**IDN 34821: OC940 Input Bit #5**

Parameter Data IDN

Binary Data

Allows the Master to read the value of the Input Bit 5 located on J43-6 of the OC940 Board.

**Note:** *User must supply Input Power to have Input Circuitry to operate.*

**Conversion Scaling Factor:** 1  
**Data Length:** 2 bytes  
**Minimum Value:** 0  
**Maximum Value:** 1  
**Access State:** Read Only by the Master.

---

**IDN 34822: OC940 Input Bit #6**

Parameter Data IDN

Binary Data

Allows the Master to read the value of the Input Bit 6 located on J43-7 of the OC940 Board.

**Note:** *User must supply Input Power to have Input Circuitry to operate.*

**Conversion Scaling Factor:** 1  
**Data Length:** 2 bytes  
**Minimum Value:** 0  
**Maximum Value:** 1  
**Access State:** Read Only by the Master.

**IDN 34823: OC940 Input Bit #7**

Parameter Data IDN

Binary Data

Allows the Master to read the value of the Input Bit 7 located on J43, Pin #8 of the OC940 Board.

**Note:** *User must supply Input Power to have Input Circuitry to operate.*

**Conversion Scaling Factor:** 1  
**Data Length:** 2 bytes  
**Minimum Value:** 0  
**Maximum Value:** 1  
**Access State:** Read Only by the Master.

---

**IDN 34824: OC940 Input Byte**

Parameter Data IDN

Binary Data

Allows the Master to read the entire Input Port. The data returned is in the following format:

Bit Number	Description	Bit Number	Description
Bit 0	Input Bit 0	Bit 5	Input Bit 5
Bit 1	Input Bit 1	Bit 6	Input Bit 6
Bit 2	Input Bit 2	Bit 7	Input Bit 7
Bit 3	Input Bit 3	Bits 8-15	undefined
Bit 4	Input Bit 4		

**Conversion Scaling Factor:** 1  
**Data Length:** 2 bytes  
**Minimum Value:** 0  
**Maximum Value:** 0x0FF  
**Access State:** Read Only by the Master.

**IDN 34825: AnalogIn**

Parameter Data IDN

Signed Decimal Number

Allows the master to read the Analog Input on the base unit. Refer to the scaling factor document for the correct Analog Input Scaling.

**Conversion Scaling Factor:** 1  
**Data Length:** 4 bytes  
**Units:** Volts  
**Minimum Value:** -2,147,483,647  
**Maximum Value:** 2,147,483,647  
**Access State:** Read Only by the Master.

---

**IDN 34826: EncPos**Parameter Data IDN  
Signed Decimal Number

Accumulated Encoder Position

**Conversion Scaling Factor:** 1  
**Data Length:** 4 bytes  
**Units:** Encoder counts  
**Minimum Value:** -2,147,483,647  
**Maximum Value:** 2,147,483,647  
**Access State:** Read Only by the Master.

**IDN 34832: OC940 Output Bit #0**Parameter Data IDN  
Binary Data

Allows the Master to write the value to Output Bit 0 located on J43-14 of the OC940 Board.

*Note: User must supply Output Power to have Output Circuitry to operate.*

**Conversion Scaling Factor:** 1  
**Data Length:** 2 bytes  
**Minimum Value:** 0  
**Maximum Value:** 1  
**Access State:** Read/Write by the Master.

---

**IDN 34833: OC940 Output Bit #1**

Parameter Data IDN

Binary Data

Allows the Master to write the value to Output Bit 1 located on J43-15 of the OC940 Board.

**Note:** *User must supply Output Power to have Output Circuitry to operate.*

**Conversion Scaling Factor:** 1  
**Data Length:** 2 bytes  
**Minimum Value:** 0  
**Maximum Value:** 1  
**Access State:** Read/Write by the Master.

**IDN 34834: OC940 Output Bit #2**

Parameter Data IDN

Binary Data

Allows the Master to write the value to Output Bit 2 located on J43-16 of the OC940 Board.

**Note:** *User must supply Output Power to have Output Circuitry to operate.*

**Conversion Scaling Factor:** 1  
**Data Length:** 2 bytes  
**Minimum Value:** 0  
**Maximum Value:** 1  
**Access State:** Read/Write by the Master.

---

**IDN 34835: OC940 Output Bit #3**

Parameter Data IDN

Binary Data

Allows the Master to write the value to Output Bit 3 located on J43-17 of the OC940 Board.

**Note:** *User must supply Output Power to have Output Circuitry to operate.*

**Conversion Scaling Factor:** 1  
**Data Length:** 2 bytes  
**Minimum Value:** 0  
**Maximum Value:** 1  
**Access State:** Read/Write by the Master.

**IDN 34836: OC940 Output Bit #4**

Parameter Data IDN

Binary Data

Allows the Master to write the value to Output Bit 4 located on J43-18 of the OC940 Board.

**Note:** *User must supply Output Power to have Output Circuitry to operate.*

**Conversion Scaling Factor:** 1  
**Data Length:** 2 bytes  
**Minimum Value:** 0  
**Maximum Value:** 1  
**Access State:** Read/Write by the Master.

---

**IDN 34837: OC940 Output Bit #5**

Parameter Data IDN

Binary Data

Allows the Master to write the value to Output Bit 5 located on J43-19 of the OC940 Board.

**Note:** *User must supply Output Power to have Output Circuitry to operate.*

**Conversion Scaling Factor:** 1  
**Data Length:** 2 bytes  
**Minimum Value:** 0  
**Maximum Value:** 1  
**Access State:** Read/Write by the Master.

**IDN 34838: OC940 Output Bit #6**

Parameter Data IDN

Binary Data

Allows the Master to write the value to Output Bit 6 located on J43-20 of the OC940 Board.

**Note:** *User must supply Output Power to have Output Circuitry to operate.*

**Conversion Scaling Factor:** 1  
**Data Length:** 2 bytes  
**Minimum Value:** 0  
**Maximum Value:** 1  
**Access State:** Read/Write by the Master.

---

**IDN 34839: OC940 Output Bit #7**

Parameter Data IDN

Binary Data

Allows the Master to write the value to Output Bit 7 located on J43-21 of the OC940 Board.

**Note:** *User must supply Output Power to have Output Circuitry to operate.*

**Conversion Scaling Factor:** 1  
**Data Length:** 2 bytes  
**Minimum Value:** 0  
**Maximum Value:** 1  
**Access State:** Read/Write by the Master.

**IDN 34840: OC940 Output Byte**

Parameter Data IDN

Binary Data

Allows the Master to read/write the entire Output Port. The data is in the following format:

Bit Number	Description	Bit Number	Description
Bit 0	Output Bit 0	Bit 5	Output Bit 5
Bit 1	Output Bit 1	Bit 6	Output Bit 6
Bit 2	Output Bit 2	Bit 7	Output Bit 7
Bit 3	Output Bit 3	Bits 8-15	undefined
Bit 4	Output Bit 4		

**Conversion Scaling Factor:** 1  
**Data Length:** 2 bytes  
**Minimum Value:** 0  
**Maximum Value:** 0x0FF  
**Access State:** Read/Write by the Master.



---

**IDN 34841: AnalogOut1**

Parameter Data IDN

Signed Decimal Number

Allows the Master to set the voltage on Analog Output 1 when DacMap 1 equals zero. The scaling for this IDN is 5/128 Volts per least significant bit (lsb).

<b>Conversion Scaling Factor:</b>	1
<b>Data Length:</b>	2 bytes
<b>Units:</b>	Volts
<b>Minimum Value:</b>	-128
<b>Maximum Value:</b>	127
<b>Access State:</b>	Read/Write by the Master.

**IDN 34842: AnalogOut2**

Parameter Data IDN

Signed Decimal Number

Allows the Master to set the voltage on Analog Output 2 when DacMap 2 equals zero. The scaling for this IDN is 5/128 Volts per least significant bit (lsb).

<b>Conversion Scaling Factor:</b>	1
<b>Data Length:</b>	2 bytes
<b>Units:</b>	Volts
<b>Minimum Value:</b>	-128
<b>Maximum Value:</b>	127
<b>Access State:</b>	Read/Write by the Master.

---

**IDN 34849: BDIO Input Pin 1**

Parameter Data IDN

Binary Data

Allows the Master to read the state of Input Pin 1 located on J4-7 of the base 900 unit.

<b>Conversion Scaling Factor:</b>	1
<b>Data Length:</b>	2 bytes
<b>Minimum Value:</b>	0
<b>Maximum Value:</b>	1
<b>Access State:</b>	Read Only by the Master.

**IDN 34850: BDIO Input Pin 2**

Parameter Data IDN

Binary Data

Allows the Master to read the state of Input Pin 2 located on J4-8 of the base 900 unit.

<b>Conversion Scaling Factor:</b>	1
<b>Data Length:</b>	2 bytes
<b>Minimum Value:</b>	0
<b>Maximum Value:</b>	1
<b>Access State:</b>	Read Only by the Master.

**IDN 34851: BDIO Input Pin 3**

Parameter Data IDN

Binary Data

Allows the Master to read the state of Input Pin 3 located on J4-9 of the base 900 unit.

<b>Conversion Scaling Factor:</b>	1
<b>Data Length:</b>	2 bytes
<b>Minimum Value:</b>	0
<b>Maximum Value:</b>	1
<b>Access State:</b>	Read Only by the Master.

---

**IDN 34852: BDIO Input Pin 4**

Parameter Data IDN

Binary Data

Allows the Master to read the state of Input Pin 4 located on J4-10 of the base 900 unit.

<b>Conversion Scaling Factor:</b>	1
<b>Data Length:</b>	2 bytes
<b>Minimum Value:</b>	0
<b>Maximum Value:</b>	1
<b>Access State:</b>	Read Only by the Master.

**IDN 34853: BDIO Input Pin 5**

Parameter Data IDN

Binary Data

Allows the Master to read the state of Input Pin 5 located on J4-11 of the base 900 unit.

<b>Conversion Scaling Factor:</b>	1
<b>Data Length:</b>	2 bytes
<b>Minimum Value:</b>	0
<b>Maximum Value:</b>	1
<b>Access State:</b>	Read Only by the Master.

**IDN 34854: BDIO Input Pin 6**

Parameter Data IDN

Binary Data

Allows the Master to read the state of Input Pin 6 located on J4-12 of the base 900 unit.

<b>Conversion Scaling Factor:</b>	1
<b>Data Length:</b>	2 bytes
<b>Minimum Value:</b>	0
<b>Maximum Value:</b>	1
<b>Access State:</b>	Read Only by the Master.

---

**IDN 34855: BDIO Input BYTE**

Parameter Data IDN

Binary Data

Returns the logic state of BDIn1-BDIn6 as a word (J4-7 to J4-12).

<b>Conversion Scaling Factor:</b>	1
<b>Data Length:</b>	2 bytes
<b>Minimum Value:</b>	0
<b>Maximum Value:</b>	0x3F
<b>Access State:</b>	Read/Write by the Master.

**IDN 34857: BDIO Output Pin 1**

Parameter Data IDN

Binary Data

Allows the Master to write the state of the Output Pin 1 located on J4-7 of the base 900 unit. If the output pin is being driven LOW by an external source, the resulting state will be low at the output pin. The BDIO Output pin is an OPEN COLLECTOR drive, reading this IDN always reads the state the 900 base unit is attempting to drive.

<b>Conversion Scaling Factor:</b>	1
<b>Data Length:</b>	2 bytes
<b>Minimum Value:</b>	0
<b>Maximum Value:</b>	1
<b>Access State:</b>	Read/Write by the Master.

---

**IDN 34858: BDIO Output Pin 2**

Parameter Data IDN

Binary Data

Allows the Master to write the state of the Output Pin 2 located on J4-8 of the base 900 unit. If the output pin is being driven LOW by an external source, the resulting state will be low at the output pin. The BDIO Output pin is an OPEN COLLECTOR drive, reading this IDN always reads the state the 900 base unit is attempting to drive.

<b>Conversion Scaling Factor:</b>	1
<b>Data Length:</b>	2 bytes
<b>Minimum Value:</b>	0
<b>Maximum Value:</b>	1
<b>Access State:</b>	Read/Write by the Master.

**IDN 34859: BDIO Output Pin 3**

Parameter Data IDN

Binary Data

Allows the Master to write the state of the Output Pin 3 located on J4-9 of the base 900 unit. If the output pin is being driven LOW by an external source, the resulting state will be low at the output pin. The BDIO Output pin is an OPEN COLLECTOR drive, reading this IDN always reads the state the 900 base unit is attempting to drive.

<b>Conversion Scaling Factor:</b>	1
<b>Data Length:</b>	2 bytes
<b>Minimum Value:</b>	0
<b>Maximum Value:</b>	1
<b>Access State:</b>	Read/Write by the Master.

---

**IDN 34860: BDIO Output Pin 4**

Parameter Data IDN

Binary Data

Allows the Master to write the state of the Output Pin 4 located on J4-10 of the base 900 unit. If the output pin is being driven LOW by an external source, the resulting state will be low at the output pin. The BDIO Output pin is an OPEN COLLECTOR drive, reading this IDN always reads the state the 900 base unit is attempting to drive.

**Conversion Scaling Factor:** 1  
**Data Length:** 2 bytes  
**Minimum Value:** 0  
**Maximum Value:** 1  
**Access State:** Read/Write by the Master.

**IDN 34861: BDIO Output Pin 5**

Parameter Data IDN

Binary Data

Allows the Master to write the state of the Output Pin 5 located on J4-11 of the base 900 unit. If the output pin is being driven LOW by an external source, the resulting state will be low at the output pin. The BDIO Output pin is an OPEN COLLECTOR drive, reading this IDN always reads the state the 900 base unit is attempting to drive.

**Conversion Scaling Factor:** 1  
**Data Length:** 2 bytes  
**Minimum Value:** 0  
**Maximum Value:** 1  
**Access State:** Read/Write by the Master.

---

**IDN 34862: BDIO Output Pin 6**

Parameter Data IDN

Binary Data

Allows the Master to write the state of the Output Pin 6 located on J4-12 of the base 900 unit. If the output pin is being driven LOW by an external source, the resulting state will be low at the output pin. The BDIO Output pin is an OPEN COLLECTOR drive, reading this IDN always reads the state the 900 base unit is attempting to drive.

<b>Conversion Scaling Factor:</b>	1
<b>Data Length:</b>	2 bytes
<b>Minimum Value:</b>	0
<b>Maximum Value:</b>	1
<b>Access State:</b>	Read/Write by the Master.

**IDN 34863: BDIO Output Byte**

Parameter Data IDN

Binary Data

Sets the logic state of the output drivers for BDOut1-6 (J4-7 to J4-12) as a word.

**Note:** If any of the BDIOMaps are non-zero, setting this IDN to a value may cause those outputs to transition, but will not affect their steady state value. In order to control all the output pins BDIOMap1-6 must be set to zero (OFF).

<b>Conversion Scaling Factor:</b>	1
<b>Data Length:</b>	2 bytes
<b>Minimum Value:</b>	0
<b>Maximum Value:</b>	0x3F
<b>Access State:</b>	Read/Write by the Master.

# Index

## A

Acceleration Data Scaling Exponent  
1-14, 6-40

Acceleration Data Scaling  
Factor 1-14, 6-40

Acceleration Data  
Scaling Type 1-13, 6-39

ADF0 5-7

Advanced Velocity Loop  
Tuning 5-9

Align Encoder Commutation Command  
1-17, 6-79

Allocation of real-time  
control bit 1 1-14, 6-46

Allocation of real-time  
control bit 2 1-14, 6-47

Allocation of real-time  
status bit 1 1-14, 6-48

Allocation of real-time  
status bit 2 1-14, 6-49

Amplifier peak current 1-13, 6-30

Analog Input 3-1

Analog Output 3-1

AnalogIn 1-17, 6-86

AnalogOut1 1-17, 6-92

AnalogOut2 1-17, 6-92

Anti-Resonance Filters

- ARF0 5-7
- ARF1 5-7
- ARZ0 5-6
- ARZ1 5-6

ARF0 1-16, 5-7, 6-75

ARF1 1-16, 5-7, 6-76

ARZ0 1-16, 5-6, 6-74

ARZ1 1-16, 5-6, 6-75

AT transmission  
starting time 1-11, 6-3

## B

BDIO Input Port 1-18, 6-95

BDIO Input1 1-17, 6-93

BDIO Input2 1-18, 6-93

BDIO Input3 1-18, 6-93

BDIO Input4 1-18, 6-94

BDIO Input5 1-18, 6-94

BDIO Input6 1-18, 6-94

BDIO Mapping 2-3

- BDIO IDNs 2-7
- Bit settings 2-6
- Cyclic Channel 2-9
- Default settings 2-5
- Example 2-8
- General purpose I/O 2-8
- Input functions 2-4, 2-6
- Output functions 2-4, 2-7
- Real Time  
Control/Status 2-10

BDIO Output1 1-18, 6-95

BDIO Output2 1-18, 6-96

BDIO Output3 1-18, 6-96

BDIO Output4 1-18, 6-97

BDIO Output5 1-18, 6-97

BDIO Output6 1-18, 6-98

BDIO Output Port 1-18, 6-98

BDIOMap1 1-15, 6-63

BDIOMap2 1-15, 6-63

BDIOMap3 1-15, 6-64

BDIOMap4 1-15, 6-64

BDIOMap5 1-15, 6-65

BDIOMap6 1-15, 6-65

BDLgcThr 1-15, 6-67

Bipolar Acceleration 1-13, 6-36



<b>C</b>		DM2Gain	1-15, 3-3, 6-61
Class 1 Diagnostic	1-11, 6-6	DAC Out units	3-4
CoastTime	1-16, 6-72	DM2Map	3-3
Command Value Proceeding Time	1-13, 6-25	DM2Map - Mux Select	1-15, 6-62
Command Value Valid Time	1-11, 6-4	Drive Controlled Homing Procedure	1-13, 6-38
CommEnbl	1-16, 6-73	DSP Debug Address	1-15, 6-55
CommOff	1-16, 5-2, 6-68	DSP Debug DWord	1-15, 6-56
CommSrc	1-17, 6-79	DSP Debug Word	1-15, 6-55
Communication cycle time	1-11, 6-1	<b>E</b>	
Communications Phase 3 Transition Check	1-13, 6-31	EncIn	1-16, 6-69
Communications Phase 4 Transition Check	1-13, 6-31	EncInFilt	1-15, 6-66
Configuration List of AT	1-11, 6-8	EncMode	1-16, 6-68
Configuration List of MDT	1-11, 6-10	EncOut	1-15, 6-62
Connection diagram	1-2, 1-3	EncPos	1-17, 6-87
Control Unit Cycle Time	1-11, 6-1	Encoder Data Scaling Method	1-16, 6-77
Controller Type	1-13, 6-36	Encoder Modulo Value	1-16, 6-78
Current Limits		<b>F</b>	
IlmtMinus	5-4	Fault Status	1-6
IlmtPlus	5-4	Feed constant	1-13, 6-30
Current Loop Integral Action Time 1	1-13, 6-29	Feedback Acquisition Capture Point	1-11, 6-4
Current Loop Proportional Gain 1	1-13, 6-28	Feedrate override	1-13, 6-29
<b>D</b>		Filter Value for ADF0	1-15, 6-59
DACMap Parameters	3-3	Firmware Version	1-16, 6-76
Diagnostic message	1-13, 6-25	Following Distance	1-14, 6-45
DM1F0	1-15, 3-1, 5-8, 6-59	<b>G</b>	
DM1Gain	1-15, 3-3, 6-60	General Purpose I/O	2-1
DAC Out units	3-4	Cyclic Channel	2-2
DM1Map	3-3	Example	2-3
DM1Map - Mux Select	1-15, 6-61	Real Time Control/Status	2-2
DM2F0	1-15, 3-1, 5-8, 6-60	Service Channel	2-1

## H

Home Switch	1-14, 6-50
Homing acceleration	1-12, 6-14
Homing parameter	1-13, 6-37
Homing velocity	1-12, 6-13
Hysteresis	1-4

## I

I/O Circuit diagram	1-5
I/O Power Source	1-4
I/O Specifications	1-4
Identification Numbers	1-11
IDN List of all Operation Data	1-11, 6-9
IDN List of all Procedure Commands	1-11, 6-11
IDN list of invalid operation data for CP2	1-11, 6-10
IDN list of invalid operation data for CP3	1-11, 6-10
IDN list of operation data for CP2	1-11, 6-9
IDN List of Operation Data for CP3	1-11
IDN List of the Configurable Data in the AT	1-14, 6-44
IDN List of the Configurable Data in the MDT	1-14, 6-45
IDNs	1-11
IlmtMinus	5-4
IlmtPlus	5-4
Input supply voltage	1-4
Input trip voltage	1-4
Interface status	1-11, 6-7
Interfaces & Connections	1-1
IPeak	5-5
ITThresh	1-16, 5-5, 6-69

## K

KII	5-1
KIP	5-1
KPP	5-3
Kvff	1-16, 5-3, 6-74
KVI	5-2
KVP	5-2

## L

LEDs	1-6
Length of Master Data Telegram	1-11, 6-5
Length of the configurable data record in the AT	1-14, 6-42
Length of the configurable data record in the MDT	1-14, 6-43
Linear position data scaling exponent	1-12, 6-20
Linear position data scaling factor	1-12, 6-19
Low-pass filters	5-6

## M

Manufacturer Class 1 Diagnostic	1-13, 6-32
Manufacturer Specific Parameters	6-52
MDT Error Counter	1-12, 6-11
MDT Transmission Starting Time	1-12, 6-24
Minimum Feedback Processing Time	1-11, 6-3
Modulo value	1-13, 6-27
Monitoring Window	1-13, 6-39
Motor	1-16, 4-1, 6-73
Read	4-1
Write	4-2
Motor Commutation	
CommOff	5-4, 6-67
Polecount	5-4, 6-57
MST Error Count	1-12

MST Error Counter	6-11	Position feedback value 1	1-12, 6-17
		Position feedback value status	1-14, 6-51
		Position Loop Kv Factor	1-13, 6-28
		Position of Data Record in MDT	1-11, 6-5
		Position Polarity Parameters	1-12, 6-18
		Positive Torque Limit Value	1-12, 6-22
		Primary Operation Mode	1-12, 6-12
		Probe 1	1-14, 6-50
		Probe 1 Enable	1-14, 2-13, 6-52
		Probe 1 Negative Latched	1-14, 6-53
		Probe 1 Positive Latched	1-14, 6-53
		Probe 2	1-14, 6-51
		Probe 2 Enable	1-14, 2-13, 6-52
		Probe 2 Negative Latched	1-14, 6-54
		Probe 2 Positive Latched	1-14, 6-54
		Probe Control Parameter	1-14, 2-12, 6-41
		Probe Value 1 Negative Edge	1-13, 6-35
		Probe Value 1 Positive Edge	1-13, 6-34
		Probe Value 2 Negative Edge	1-13, 6-36
		Probe Value 2 Positive Edge	1-13, 6-35
		Probe/Registration Functionality	2-11
		CyclicChannel	2-15
		Example	2-14, 2-15
		Real Time Control /Status Bits	2-15
		Service Channel Operation	2-12
		Probe 1 Enable	2-12
		Probe 2 Enable	2-12
<b>N</b>			
NVLoad	1-17, 6-80		
NVSave	1-17, 6-80		
Negative torque limit value	1-12, 6-22		
<b>O</b>			
OC940 Input Bit #0	1-17, 6-82		
OC940 Input Bit #1	1-17, 6-82		
OC940 Input Bit #2	1-17, 6-83		
OC940 Input Bit #3	1-17, 6-83		
OC940 Input Bit #4	1-17, 6-84		
OC940 Input Bit #5	1-17, 6-84		
OC940 Input Bit #6	1-17, 6-85		
OC940 Input Bit #7	1-17, 6-85		
OC940 Input Port	1-17, 6-86		
OC940 Output Bit #0	1-17, 6-87		
OC940 Output Bit #1	1-17, 6-88		
OC940 Output Bit #2	1-17, 6-88		
OC940 Output Bit #3	1-17, 6-89		
OC940 Output Bit #4	1-17, 6-89		
OC940 Output Bit #5	1-17, 6-90		
OC940 Output Bit #6	1-17, 6-90		
OC940 Output Bit #7	1-17, 6-91		
OC940 Output Port	1-17, 6-91		
OC940 outputs	1-6		
Output Voltage	1-4		
Overview of OC940	1-1		
<b>P</b>			
Pole Count	1-15, 5-2, 6-58		
PosErrorMax	1-15, 6-58		
Position Command Value	1-12, 6-16		
Position Data Scaling Type	1-12, 6-19		

Probing Cycle Procedure Command 1-14, 2-13, 6-42  
 Pull up resistor 1-4

## R

Receive to Receive recovery Time 1-12, 6-24  
 Reference distance 1 1-12, 6-17  
 RemoteFB 1-15, 6-67  
 Reset Class 1 Diagnostic 1-13 , 6-26  
 Resolver Position 1-17, 6-81  
 Rotational Position Resolution 1-12, 6-20

## S

S1 switch  
   address table 1-8  
   location 1-7  
   settings 1-7  
 SERCOS Specific Parameters 6-1  
 Serial Addresses 1-7  
 Shortest AT Transmission Starting Time 1-11, 6-2  
 Slave Arrangement 1-13, 6-25  
 Slave Tx Level 1-15, 6-56  
 StopTime 1-16, 6-70  
 SYSTEM Interface Version 1-13, 6-37

## T

Telegram type parameter 1-11, 6-8  
 Transmit/receive transition time 1-11, 6-2  
 Torque command value 1-12, 6-21  
 Torque feedback value 1-12, 6-23  
 Torque polarity parameter, 1-12, 6-23  
 Tuning equations 5-1

## V

VBusThresh 1-16, 6-70  
 VelLmtHi 1-16, 6-71  
 VelLmtLo 1-16, 6-71  
 Velocity Command Value 1-12, 6-12  
 Velocity Data Scaling Exponent 1-12, 6-16  
 Velocity Data Scaling Factor 1-12, 6-15  
 Velocity Data Scaling Type 1-12, 6-15  
 Velocity Feedback Value 1-12, 6-13  
 Velocity Loop Integral Action Time 1-13  
 Velocity Loop Integral Gain 6-27  
 Velocity Loop Proportional Gain 1-13, 6-26  
 Velocity Polarity Parameter 1-12, 6-14

## W

Wave Shaping 4-1  
 WaveShape Coefficient List IDN 1-16, 4-4, 6-78