

P70360 (AC) High Performance Micro-stepping Drive

Quick Start Guide
Part # M-SD-7AC-07
Initial Release

NOTE: This is only a Quick Start Guide. Visit our website at <http://www.kollmorgen.com/documents/> or browse the Product Support Package CD-ROM shipped with your product to find the complete Installation Reference.

Keep all product manuals as a product component during the life span of the stepper drive.

Pass all product manuals to future users/owners of the stepper drive.

KOLLMORGEN[®]

Because Motion Matters™



Copyright Information

© Copyright 2006 Kollmorgen – All rights reserved.
Printed in the United States of America

Notice

Not for use or disclosure outside of Kollmorgen except under written agreement. All rights are reserved. No part of this book shall be reproduced, stored in retrieval form, or transmitted by any means, electronic, mechanical, photocopying, recording, or otherwise without the written permission from the publisher. While every precaution has been taken, the publisher assumes no responsibility for errors or omissions. Neither is any liability assumed for damages resulting from the use of the information contained herein.

This document is proprietary information of Kollmorgen that is furnished for customer use ONLY. Information in this document is subject to change without notice and does not represent a commitment on the part of Kollmorgen. Therefore, information contained in this manual may be updated from time-to-time due to product improvements, etc., and may not conform in every respect to former issues.

Kollmorgen reserves the right to make engineering refinements on all its products. Such refinements may affect information in instructions..

Safety



WARNING

Read this guide before you apply power to the drive. Mis-wiring of the drive may result in damage to the unit voiding the warranty. Improper grounding of the drive may cause serious injury to the operator.

Only qualified personnel are permitted to transport, assemble, commission, and maintain this equipment. Properly qualified personnel are persons who are familiar with the transport, assembly, installation, commissioning and operation of motors, and who have the appropriate qualifications for their jobs.

Read all available documentation before assembling and using. Incorrect handling of products in this manual can result in injury and damage to persons and machinery. Strictly adhere to the technical information regarding installation requirements.

Keep all covers and cabinet doors shut during operation.

Be aware that during operation, the product has electrically charged components and hot surfaces. Control and power cables can carry a high voltage, even when the motor is not rotating.



CAUTION

Never disconnect or connect the product while the power source is energized.

After removing the power source from the equipment, wait at least 2 minutes before touching or disconnecting sections of the equipment that normally carry electrical charges (e.g., capacitors, contacts, screw connections). To be safe, measure the electrical contact points with a meter before touching the equipment.

120 V Wiring

Connection for a 320 VDC
bus using 120 VAC.

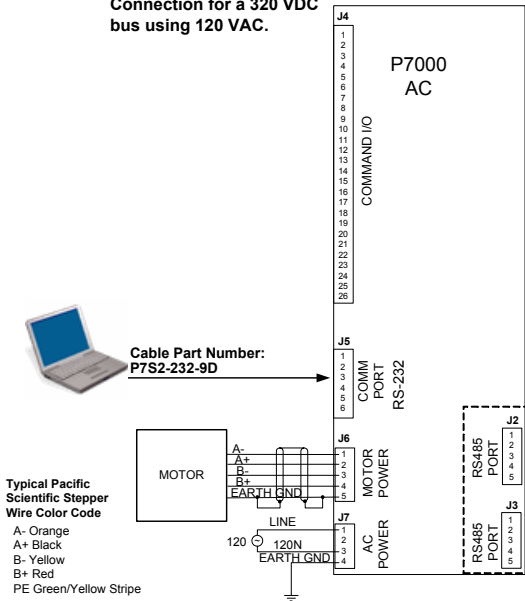

240 V Wiring

Connection for a 320 VDC
bus using 240 VAC.

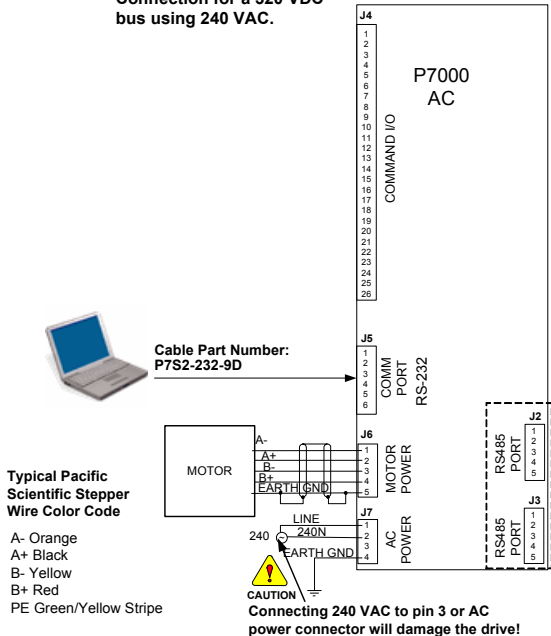

Install P7000Tools

Install P7000Tools either from the Product Support Package CD-ROM or download it from the website (www.kollmorgen.com). When you install P7000Tools, the Installation Wizard will check to see if you have a previous version of P7000Tools on your system. If found, it will uninstall it. After this, you will need to run the installation again to install the new version on your system.

If you do not have a previous version of P7000Tools on your system, you only need to run the installation once.

Setup Wizard

Start **P7000Tools**. Follow the **Setup Wizard**. Choose your motor and accept all other default values.



Go to the Advanced Setup screen.

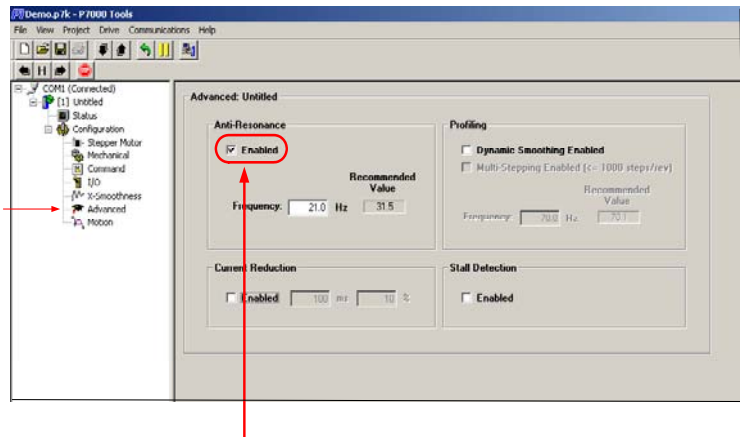





Enable the "Anti-Resonance" function.

Motion Toolbar

Go to the Motion Toolbar.



	Jog Motor Negative	Jogs the motor in the negative direction at the selected velocity
	Jog Velocity Toggle	Selects the active jog velocity for the Jog arrow buttons (L designates Low Speed, H designates High speed)
	Jog Motor Positive	Jogs the motor in the positive direction at the selected velocity
	Stop Motion	Stops all Motion Node generated motion and breaks any active move sequence



CAUTION

The motor shaft will rotate when performing the test below!!

- 1) Jog the motor Negative.
- 2) Jog the motor Positive.

If successful, your system is now ready for programming for your application. Refer to the Installation Reference found on the Product Support Package CD-ROM or download it from the website (www.danahermotion.com).

Status Display

There are 7 faults that may occur with the P7000 drive. The fault output latches when they occur. Determine the type of fault by viewing the front panel or through the serial port. The front panel LED turns red and blinks according to the table below.

LED Color	Blinks	Description	Cause	Solution
Green	Solid	System OK	NA	NA
Green	1	Amplifier is disabled	The enable input (J4-5 & J4-6) is not asserted if ENABLE is configured ACTIVE CLOSED or the enable input is asserted if ENABLE is configured ACTIVE OPEN.	De-assert the enable input or disable the soft shutdown from P7000Tools.

LED Color	Blinks	Description	Cause	Solution
Amber	Solid	EOT± input latched	An EOT (End of Travel) input is latched.	Move system in the opposite direction until the active EOT input transitions from asserted to de-asserted.

LED Color	Blinks	Description	Cause	Solution
Red	Solid	FLASH memory fault	A FLASH memory checksum validation has failed indicating corruption of the operating system. This typically occurs during firmware download.	Without attempting to connect to the drive, download the most current firmware file from the P7000Tools menu option Drive->Update Operating System.... If the FLASH download utility fails, contact technical support.

LED Color	Blinks	Description	Cause	Solution
Red	1	Stall Fault	The Encoderless Stall Detection feature has detected that the motor has slipped or stalled.	Reduce move profile acceleration, velocity, deceleration or load inertia. Power cycle or reset drive via Fault Reset input or P7000Tools.
Red	2	Over-current Fault	An event has occurred which caused the amplifier output current to exceed 5.6 amps.	Check motor wiring for shorts. Power cycle or reset drive via Fault Reset input or P7000Tools.

LED Color	Blinks	Description	Cause	Solution
Red	3	Over-voltage Fault	A regenerative event has occurred which forced the bus voltage above 440 VDC. Incoming AC line voltage too high.	Reduce deceleration, load inertia, or reduce deceleration duty cycle to allow enough time for the power dump circuit to recover. Power cycle or reset drive via Fault Reset input or P7000Tools.

LED Color	Blinks	Description	Cause	Solution
Red	4	Drive Over-temp Fault	The temperature of the heatsink has exceeded 70° C.	Reduce ambient temperature or system duty cycle. Power cycle or reset drive via Fault Reset input or P7000Tools.
Red	5	System Fault	An error occurred while attempting to converge on a solution while running the Motor Probe or Auto X-Smoothness Probe.	Power cycle or reset drive via Fault Reset input or P7000Tools.

LED Color	Blinks	Description	Cause	Solution
Red	6	Under-voltage Fault	Attempting to operate the unit at a bus voltage below 10 VDC. Incoming AC line voltage too low.	Power cycle or reset drive via Fault Reset input or P7000Tools.
Red	7	EEPROM Checksum Fault	User non-volatile memory checksum validation has failed indicating user setup corruption.	Restore default configuration from the P7000Tools menu option Drive->Restore Default Configuration ...
Red	Constant Blinking	Processor Fault	Illegal Address	Contact technical support.

LED Color	Blinks	Description	Cause	Solution
Alternating Red & Amber	Multi	Processor Fault	Internal system error.	Contact technical support.

The blinking continues until the drive is reset by one of the following methods:

- Power Cycle
- GUI Control
- Fault Reset (Configurable General Purpose Input)

Sales and Service

Kollmorgen is committed to quality customer service. Our products are available world-wide through an extensive authorized distributor network. To serve in the most effective way, please contact your local sales representative for assistance. If you are unaware of your local sales representative, please contact us.

Europe

Kollmorgen Customer Service Europe

Email: support@kollmorgen.com

Phone: +49(0)203 9979 0

Fax: +49(0)203 9979 155

Web: www.Kollmorgen.com

North America

Kollmorgen Customer Service North America

Email: support@kollmorgen.com

Phone: 1-540-633-3545

Fax: 1-540-639-4162

Web: www.Kollmorgen.com

KOLLMORGEN®

Because Motion Matters™