

This is a Discontinued Product

Contact Kollmorgen Customer Support at
1-540-633-3545 or email us at support.kollmorgen.com
if assistance is required.

DO NOT DISCARD

In a continuing effort to satisfy our customers, Danaher Motion has provided this packet of instructions with your product. This information provides safety, warranty, and liability information. This information enables you, the customer to get this unit up and running. The included CD-ROM has all the technical manuals in PDF format. For your convenience, Adobe®'s Acrobat Reader can also be installed from this CD-ROM. Danaher Motion's technical documentation is subject to change without notice. Be sure to check the website for the latest version (www.DanaherMotion.com).

PC830 CE Compliance

Use Conforming with Requirements

The equipment described herein has been developed, produced, tested and documented in accordance with the corresponding standards. During use conforming with requirements, the equipment is not dangerous for people or equipment. Use conforming with requirements means that the safety recommendations and warnings detailed in this manual are complied with and that the applicable regulations for safety (machine directives, etc.) and noise suppression (EMC Directives) are observed while operating the drive. At the end of its lifetime, dispose of or recycle the drive according to the regulations applicable at that time.

CE-Approval

The CE initials confirm that the PC832, PC833 and PC834 drives satisfy all requirements of CE Directives. The equipment is not ready to operate without additional installations (cable, motor, etc.). Thus, all necessary tests and measurements had to be made on a typical installation. The test installation with all peripheral devices, as well as the test results and measurements are recorded in detail in documentation that is available from the manufacturer on request.



NOTE

If the connection method on your machine is different from the one picture used in the factor, or in the event of use of components other than those that we have specified, adherence to interference limit values cannot be guaranteed.

Declaration of Conformity

In our Declaration of Conformity, we affirm our compliance with Directive 73/23/EEC (Low voltage Directive) and with Directive 89/336/EEC (EMC Directive).

For the PC8x2/PC8x3 and PC8x4, EMC testing was done according to EN61800-3 (Emission limits according to chapter 6.3.1 of that regulation, First environment / restricted distribution).

During assembly of our product in a machine, startup (that is, normal operation) is prohibited until the end-product complies with Directive 89/392/EEC (Machine Directive) and directive 89/336/EEC (EMC Directive).

The machine manufacturer must prove that the complete system conforms with all relevant European Directives.

Qualified Personnel for Installation and Commissioning

Installation and wiring of the drive must be completed only by qualified personnel having a basic knowledge of electronics, installation of electronic and mechanical components, and all applicable wiring regulations.

Commissioning of the machine utilizing the drives must be done only by qualified personnel having broad knowledge of electronics and motion control technology.

Safety Requirements

As the user or person applying this unit, you are responsible for determining the suitability of this product for the application. In no event will Danaher Motion be responsible or liable for indirect or consequential damage resulting from the misuse of this product.

European Directives

Comply with the applicable European standards and Directives. In Germany these include:

- DIN VDE 0100 (instructions for setting up power installations with rated voltages below 1000 V).
- DIN - EN 60 204 - Part 1, (VDE 0113, part 1) instructions relative to electric equipment in machines for industrial use.
- prDIN EN 50178, (VDE 0160) equipping high-voltage current installations with electronic operating means.

Safety Requirements

The following requirements must be met to ensure compliance with the Low Voltage Directive:

- Never connect or disconnect any drive connectors or terminals while the power is switched on.
- The climatic conditions shall be in accordance with EN 50178 climatic class: Type B, temperature and relative humidity: Class 3K3.
- This drive is to be installed inside a motor/control cabinet accessible by qualified personnel only.
- Electronic drives contain electrostatic sensitive devices which can be damaged when handled improperly. Qualified personnel must follow ESD protection measures. For example: wear grounded heel and wrist straps when contacting drive.
- The discharge time for the bus capacitors may be as long as 5 minutes. After disconnecting the drive from the ac mains be sure to wait 5 minutes before removing the drive's cover and exposing live parts.
- Follow IEC 536-2 and IEC 1140 for installation protection against electric shock.
- Installation shall be performed in accordance with local electric codes, local accident prevention rules, EN 50178 and EN 61800-3.
- Due to high leakage current this drive is to be permanently installed (i.e. hard wired). The PE connection shall be made by two separate conductors between the earth ground and the two PE terminals on the device.
- Consult the factory before using this product on a circuit protected by a residual-current-operated protective device (RCD).
- External, supply line, fusing is required. PC833: Bussman, MDA-20, PC834: Littlefuse, FLM 30.
- Motor cable shield must be connected to protective earth.
- All covers shall be closed during operation.
- During periods of extreme regeneration or excessively high input voltage the temperature of the regen resistor may exceed 70° C.
- When using an external regen resistor, if regen cabling is accessible during normal machine operation, regen resistor cable should be rated at 450 VDC and shielded with shield connected to PE.

Requirements for Safe Operation of the Drive

It is the machine builder's responsibility to insure that the complete machine complies with the Machine Directive (EN60204). The following requirements relate directly to the servo controller:

Emergency Stop

If personal injury can result from motor motion, the user must provide an external hardwired emergency stop circuit outside the drive. This circuit must simultaneously remove power from the drive's motor power terminal TB1-11, TB1-12, and TB1-13 and disable the drive (by disconnecting J2 pin 37 from I/O RTN).



NOTE

The motor coasts under this condition with no braking torque.

If braking torque is required to quickly stop the motor, a dynamic brake can be added that loads the motor's windings resistively. The motor should not be loaded until the servo drive is disabled. The holding brake, optional on Danaher Motion Pacific Scientific motors, is not intended to stop a spinning motor. It is designed to prevent a stopped motor from rotating due to an applied torque.

Avoiding Unexpected Motion

Always remove power from TB1 before working on the machine or working anywhere where injury can occur due to machine motion.

Avoiding Electrical Shock

Never power the servo drive with the cover removed or with anything attached to circuitry inside the cover.

If the drive must be removed from the cabinet, wait at least five minutes after turning off power before removing any cables from the drive or removing the drive from the mounting panel.

Never connect or disconnect any wiring to the drive while power is applied. Always power down and wait five minutes before connecting or disconnecting any wires to the terminals.

Avoiding Burns

The temperature of the drive's heat sink and housing as well as an external regen resistor can exceed 70° C. Therefore, there is a danger of severe burns if these regions are touched.

Preventing Damage to the Drive

Follow these guidelines to prevent damage to the servo drive during operation:

- Never plug or unplug connectors with power applied.
- Never connect or disconnect any wires to terminals with power applied
- Never plug or unplug an option card with control power applied
- If the drive indicates a fault condition, find the cause of the fault and fix it prior to resetting the fault or power-cycling the drive.

UL Recognition

File number E137798

Grounding Shields for Safety and Low Emissions/Susceptibility

Dangerous voltages, resulting from cable capacitance, exists on some cable shields if the shields are not connected to PE ground. Proper grounding of shields is also required to reduce radiated and conducted emissions as well as to protect against susceptibility to external and self generated noise. Follow these shielding requirements carefully:

The drive end of the motor cable shield must be connected to the PE or Ⓧ location on the TB1 connector. The shield must also be clamped to the ground plane as described above. If cable with a separate inner foil shield and outer braided shield is used (Pacific Scientific CE cables for example), connect the foil shield to the PE or Ⓧ location on the TB1 connector and clamp the outer braided shield to the ground plane. If the leads for a motor holding brake are run with the motor leads, the holding brake leads must be separately shielded and the shield connected to the PE or Ⓧ location on the TB1 connector.

The resolver cable should have inner shields around each twisted pair as well as an overall outer braided shield. The inner shields should be connected to J3 pin 5 while the outer shield should be clamped to the ground plane.

The control leads to the J2 connector should have an outer braided shield with the shield terminated through a conductive shell or clamped to the ground plane.

When using an external regen resistor, if regen cabling is accessible during normal machine operation, regen resistor cable should be rated at 450 VDC and shielded with shield connected to PE.

Sensitive cables such as telephone lines should be separated/isolated from motor and resolver cables.

Grounding the Motor Case

Insure that the motor's case is connected to PE ground. This is accomplished by the fourth wire in the motor cable connecting TB1-10 Ⓧ to the motor case.

If the motor is not properly grounded, dangerous voltages can be present on the motor case due to capacitive coupling between the motor windings and case.

Long Motor Power Cables

The PC800 drives do not require additional filtering in the motor leads as long as the motor power cable (between drive connector TB1 and the motor) is less than 10 meters (32 feet) long. For longer motor power cables, an external balun must be added in series with the cable. Additional information can be found in Danaher Motion Pacific Scientific Application Notes 106 (*Reducing Motor Drive Line Noise*) and 107 (*Reducing Motor Drive Radiated Emissions*).



NOTE

Balun part number is 104-090003-01.

Current Rating	60 A sinewave pk (42 A _{RMS}) 5 sec. 20 A sinewave pk (14 A _{RMS}) cont.
Inductance	340 µH nominal
Energy Rating	7,200 µj nominal
Resistance	0.021 ohm nominal
Gap	10 mil

EMC

The following requirements must be met to ensure compliance with the EMC Directives:



WARNING

Not intended to be used on a low-voltage public network which supplies domestic premises. May cause radio frequency interference.

Line Filter

To meet the conducted EMC requirements, an external line filter is necessary. It is your responsibility to choose appropriate filtering for the application. Danaher Motion is willing to assist in this choice. The CE test setup included a 50CE4 line filter manufactured by MTE. CE testing was performed using 50 m motor and resolver cables, the maximum lengths specified, to prove worst case conducted emissions compliance. For CE testing with 50 m cables, a motor cable balun was added to the motor wiring (part number 104-090003-01). The line filter should be mounted as close as possible to the drive. To provide maximum high frequency filtering, remove any paint from between the filter, the drive and the conductive surface ground plane to which they are bonded.

MTE Corporation
1-800-455-4MTE or 414-253-8200
<http://www.mtecorp.com>

Shielding & Grounding

To meet radiated EMC requirements, shield and ground the serial, Command I/O, motor and resolver cables at the drive end. To guarantee maximum high frequency radiated noise reduction, the shields should have 360° termination to ground. Clamp the exposed portion of the shields to the front of the drive with the clamp supplied to terminate. The serial and command I/O cables can be terminated to ground through the D-sub connector, if it provides 360° shield termination. It may also be necessary to add ferrites to the Command I/O and serial cables. It is important to remove the paint from any grounding surfaces.

To avoid the risk of cross-talk, keep the motor and resolver cables away from sensitive signal cables such as telephone and intercommunication lines.

CE Block Diagram

EMC - Test Configuration

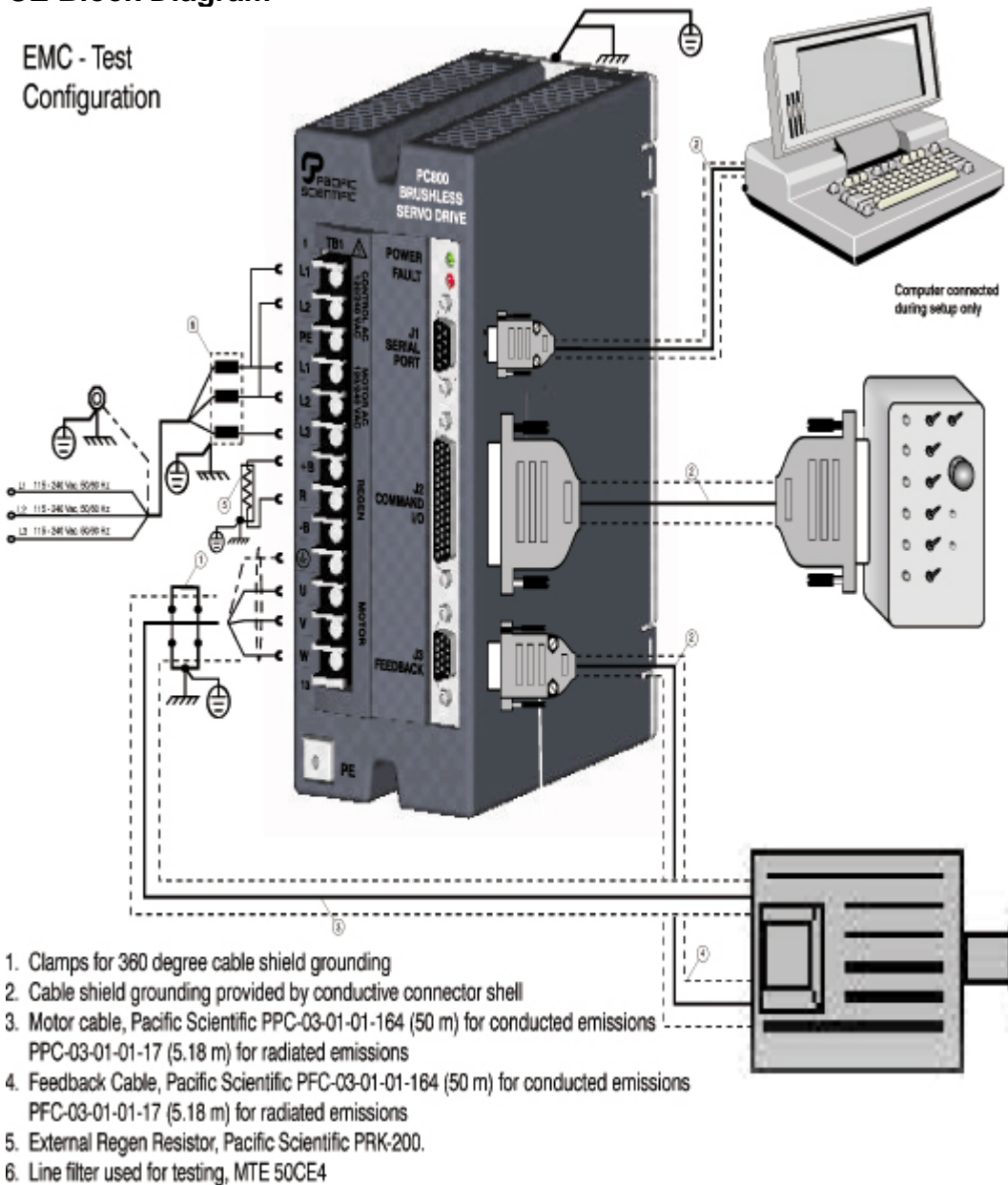

Installing the PC800 Servo Drive

Much of the connection information presented in this section is summarized in the next figure.

Mounting the Drive

The PC800 drives are designed for operation in a cabinet. Follow these installation instructions:

1. Mount the drives vertically inside a cabinet on a flat, solid, electrically conductive, mounting surface (connected to PE (protective earth ground) and capable of supporting the weight of the unit).
2. Remove the paint on the mounting surface over an area extending at least 12 mm (0.5") from the mounting bolts to achieve good electrical connection over a large area between the drive and grounded mounting surface.
3. Install conductive clamps near the drive on the mounting panel (ground plane) for electrically connecting the outer shield of certain cables (defined below) to the panel.

4. Attach the conductive clamps to PE on the front of the drive.
5. Remove about 10mm (0.5") of the outer jacket of these cables where the clamp will be to expose the braided shield before inserting under the clamp and tightening. The length of the cable between the drive connection and the clamp should be as short as possible (not exceeding 0.6 meters or two feet). If a ground plane is available at the other end of these cables, use a conductive clamp at that end to connect the shield to that ground plane as well.
6. Provide a minimum unobstructed space of 100 mm (4") above and below the drive. With convection cooling, provide 40mm (1.6") free space on either side of each unit. With forced air cooling, no free space is required on either side of each unit.
7. Insure the environment within the cabinet meets the requirements defined on page 15.

The PC830 packaging is totally enclosed single axis panel mount. The next figure gives the key dimensions for use in physically mounting the product. When mounting multiple units on one panel there should be at least 20 mm (0.75") of air space on the sides and 40 mm (1.5") or air space above and below the unit.

When mounting multiple drives in a row, the stiffness of the drive and the mounting panel may be too low. To increase the mounted mechanical integrity, connect to the threaded insert on the top front edge.

The overall drive panel dimensions and the mounted depth, not including mating connectors, is listed in the below chart. The extra depth for mating connectors is 1.0" or less.

Dimensions			
Model	Height	Width	Depth
PC8x2	198.1 mm/7.8"	88.1 mm/3.47"	158 mm/6.22"
PC8x3	198.1 mm/7.8"	88.1 mm/3.47"	158 mm/6.22"
PC8x4	198.1 mm/7.8"	114 mm/4.49"	158 mm/6.22"

Weight	
Model	Weight
PC8x2	1.9 kg/4 lb
PC8x3	2 kg/4.3 lb
PC8x4	2.6 kg/5.7 lb

Mounting Guidelines

The mounting dimensions gives the key dimensions for use in physically mounting the product.

When mounting multiple drives in a row, the stiffness of the drive and the mounting panel may be too low. To increase the mounted mechanical integrity, connect to the threaded insert on the top front edge.

The overall drive panel dimensions and the mounted depth (not including mating connectors) are listed in the below chart. The extra depth for mating connectors is 1.0" or less.

Mounting Dimensions

PC8x2/3/4

Inches [mm]

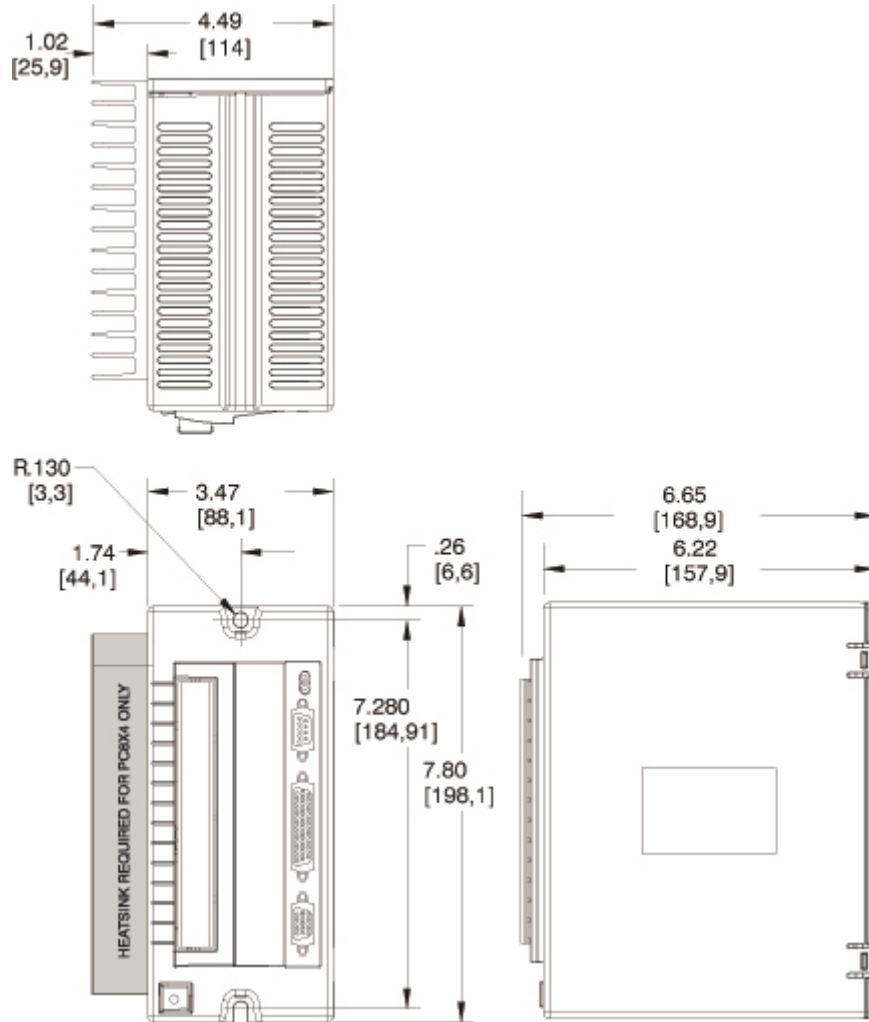

PC830 Terminal Block Adapter (CA800-TB)

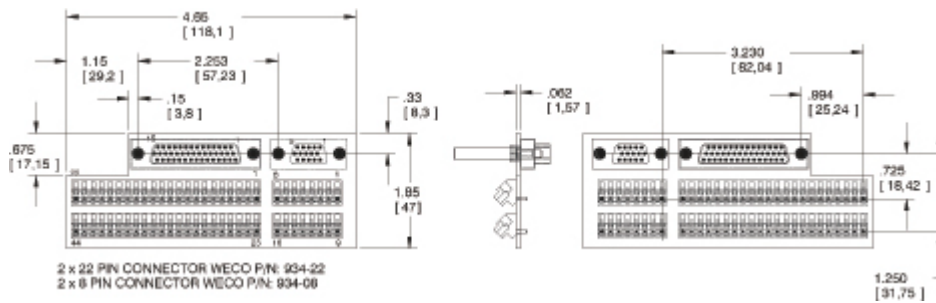

Fan Option Kit (PFK-120/PFK-240)

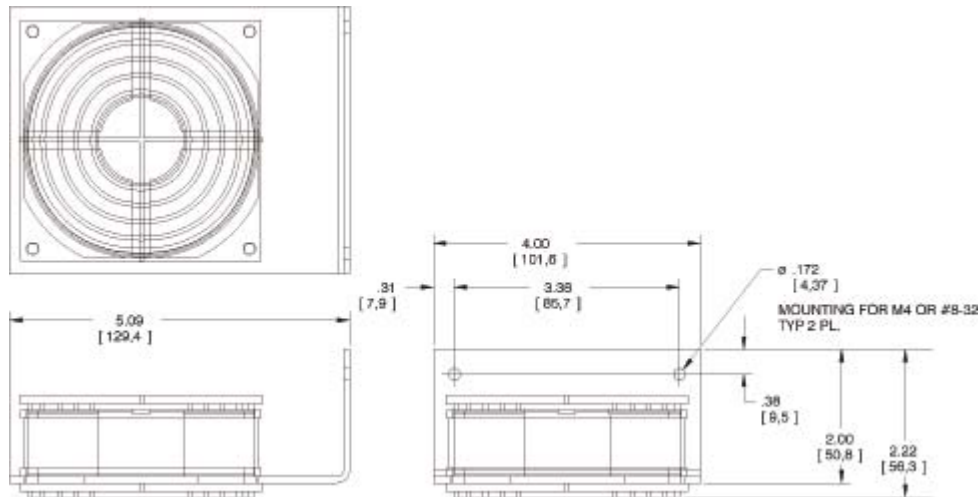

Connecting to AC Power

The PC800 series drives are functionally compatible with all standard forms of three phase AC lines:

- Grounded neutral WYE
- Open-Delta Grounded Leg
- TEE

The AC power source for connector TB1 (control power supply) can be either single phase 115-240 VAC referenced to neutral (PE) or a symmetrical 115-240 VAC to neutral.

Fusing

Use slow blow fuses in series with TB1 pins 1, 2, and 3 as shown in the figure on page 6.

Model	Fuse
PC8x2	Bussman, MDA-10
PC8x3	Bussman, MDA-20
PC8x4	Littlefuse, FLM 30

External Regen

The clearest indication that an external regen resistor is needed, is that the drive faults on over-voltage when the motor decelerates. The Fault LED is solid on and the variable FaultCode shows 'over-voltage' or 'external regen fault'. For additional information regarding this topic, refer to the manual, part number MA830.

Regen R Characteristics

Danaher Motion offers a regen resistor for the PC800 family (Part #PRK-200). The same regen resistor is used for the PC8x4 and PC8x3. It is a 12.5 Ω , 200W, metal clad, panel mount resistor supplied with a short cable for attachment to the drive.

Ohms	12.5 W \pm 10%
Watts	200 watts (manufacturer rating 300 watts)
Terminals	0.25 inch standard fast-on
Isolation	3,500 V to case
Cable	2 ft, #16AWG, with spade lugs (for TB1)

Mounting and Wiring

The PC800 the regen resistor is mounted external to the drive. The factory-supplied PC800 regen resistor comes with a cable long enough to mount it adjacent to the drive and be wired to the drive.

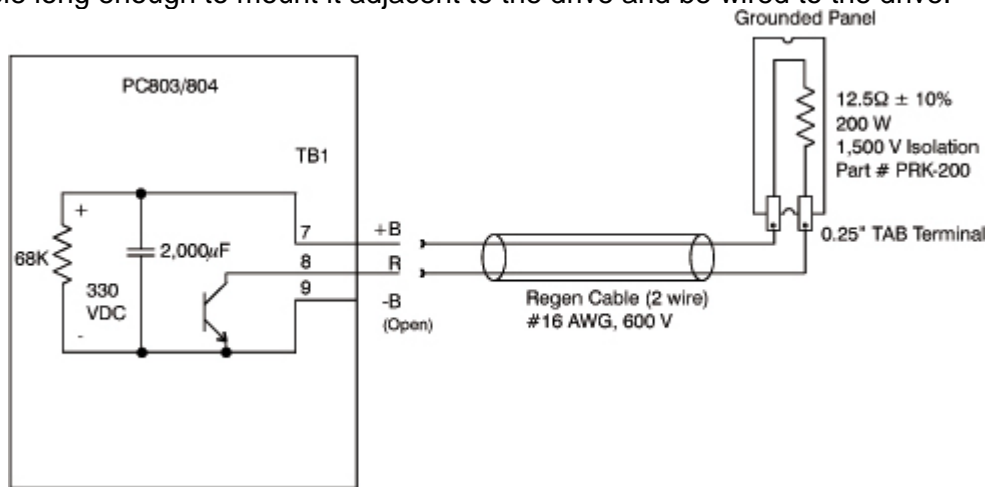

WARNING

Wait 10 minutes after Bus Power is removed for the bus cap voltage to decay to a safe level before touching regen resistor or wiring. Monitor the voltage on the bus caps with a voltmeter from +BUS (TB1-7) to -BUS (TB1-9).



CAUTION

High Voltage

During normal operation +B, R, and -B operate at the bus power voltages. A 240 VAC system operates at at 400 VDC. These are dangerous voltages!

Drive Regen Terminals

TB1-7 (marked +B) to TB1-8 (marked R)

The resistor terminals are standard 0.25 in fast-ons. Mount the resistor any distance from the drive using a customer supplied cable. Recommended cable wire is #16 AWG, 600V rated, teflon.

Safety

Shield the terminals of the regen resistor from contact as they are electrically connected to the +Bus of the drive. The regen terminals are at dangerous, potentially lethal, voltages whenever the drive bus power is on and for about 10 minutes after bus power is turned off.

To prevent the metal case of the resistor from becoming a safety hazard in the event of internal resistor failure, ground the resistor case by attaching it to a grounded panel.

Customer-Supplied Regen Resistors

Customer-supplied regen resistor(s) can be used. Be sure the resistance seen by the drive is within 10% of 12.5 Ω and the isolation of the resistive element is a minimum of 1,500 V. Two 25 Ω resistors in parallel form a 12.5 Ω resistor.

High Power Regen

In an application with very high average regenerated power, it may be necessary to increase the wattage of the regen resistor. Quick test: 'Does water boil on the surface of the resistor'?. One way to increase the regen resistor power handling capability is to blow air on it.

A simple way to increase regen power handling capability is to replace a single 12.5 W regen resistor with four similar 12.5 W resistors wired in series-parallel. Series parallel wiring is two pairs wired in series (25 W each pair) and the two pairs wired in parallel (12.5 Ω total). Use a meter to check the resistance of a combination is 12.5 Ω before attaching it to the drive. Four 200 Ω regen resistors wired in series parallel can handle 800 Ω .

Fusing

If the regen transistor in the drive should fail shorted, the power into the external regen resistor increases far above its ratings. For three phase 240 VAC bus power, the power in the regen resistor is about 8.2 kW (320 VDC across 12.5 Ω equals 25.6 ADC). After a few minutes, the regen resistor typically opens. In the meantime, the high heat can cause melting and damage to nearby components. A remote regen resistor mount, away from other structure say on top of a cabinet, minimizes the potential harm.

A single 200 Ω regen resistor can (in some cases) be fused, but the fuse type and rating must be carefully chosen. Due to the resistance a large pulse of current is not available to clear a fuse. While not tested, analysis of fuse time-current curves indicates the following fuse should work with a single 12.5 Ω regen resistor and a drive operated on a three phase 240 VAC line:

10A, Time Delay, 250V
Buss MDA 10 or Littlefuse 326010

If bus power is single phase (240 VAC, 208 VAC, or 120 VAC), regen fusing is difficult and not recommended. Fusing of high power (800 Ω) regen is also not recommended.

PC830 Connector Pinouts

TB1 - 13 Position Terminal Strip

Pin	Label	Description
TB1-1	L1	240/120 VAC Control Power
TB1-2	L2	240/120 VAC Control Power
TB1-3	PE	Chassis Ground
TB1-4	L1	240/120 VAC (Input)
TB1-5	L2	240/120 VAC (Input)
TB1-6	L3	240/120 VAC (Input)
TB1-7	+B	+ Bus
TB1-8	R	Regen Transistor
TB1-9	-B	- Bus
TB1-10	PE	Chassis Ground
TB1-11	U	Motor Phase U
TB1-12	V	Motor Phase V
TB1-13	W	Motor Phase W

J1 - 9 Position D Subminiature Female

Pin	Input/Output	Explanation
J1-1	+5 VDC RTN/ Shield	Common/shield - serial port interface
J1-2	RS-232 TXD	RS-232 transmitter output (from PC830)
J1-3	RS-232 RXD	RS-232 receiver input (to PC830)
J1-4	+5 VDC	+5 VDC output (250 mA maximum between J1-4 & J1-5)
J1-5	I/O RTN/+5 VDC RTN	Common serial port interface
J1-6	RS-485 TXD (+)	RS-485 transmitter output (from PC830)
J1-7	RS-485 TXD (-)	
J1-8	RS-485 RXD (+)	RS-485 receiver input (to PC830)
J1-9	RS-485 RXD (-)	

J2 - 44 Position D Subminiature Female

Pin	Description	Pin	Description
J2-1	Analog Command Input (+)	J2-23	No Connect
J2-2	Analog Command Input (-)	J2-24	Relay Output (+) (Out4)
J2-3	I/O RTN	J2-25	Relay Output (-) (Out4)
J2-4	Analog Output1 (DacMonitor1)	J2-26	No Connect
J2-5	Analog Output2 (DacMonitor2)	J2-27	No Connect
J2-6	Analog Current Limit Input	J2-28	Analog Input 2
J2-7	I/O RTN	J2-29	Analog Input 3
J2-8	Encoder Output Channel A	J2-30	I/O RTN
J2-9	Encoder Output Channel A	J2-31	Input 1 (Fault Reset)
J2-10	Encoder Output Channel B	J2-32	Input 2 (CwlNh)
J2-11	Encoder Output Channel B	J2-33	Input 3 (Ccwlnh)
J2-12	Encoder Output Channel Z	J2-34	Input 4 (Reg1)
J2-13	Encoder Output Channel Z	J2-35	Input 5 (Reg2)
J2-14	+5 VDC (Output)	J2-36	Input 6
J2-15	I/O RTN/ +5 VDC RTN	J2-37	Enable Input
J2-16	I/O RTN	J2-38	Input RTN
J2-17	Command Encoder Input Channel A (Step)	J2-39	+24 VDC Output RTN
J2-18	Command Encoder Input Channel A (Step)	J2-40	+24 VDC (Output)
J2-19	Command Encoder Input Channel B (Dir)	J2-41	Out1, 2, 3 Supply (Input)
J2-20	Command Encoder Input Channel B (Dir)	J2-42	Out1 (Fault)
J2-21	No Connect	J2-43	Out2 (Brake)
J2-22	No Connect	J2-44	Out3

J3 - FEEDBACK 15 Position D Subminiature Female

Pin	Description
1	RESOLVER S1 SIN + (Input) / Hall 1
2	RESOLVER S3 SIN - (Input) / Hall 2
3	RESOLVER S2 COS + (Input) / Hall 3
4	RESOLVER S4 COS - (Input)
5	SHIELD (I/O RTN)
6	RESOLVER R1 EXCITATION (Output)
7	RESOLVER R2 EXCITATION RTN (Output)
8	MOTOR PTC (Input)
9	MOTOR PTC RTN (Input)
10	+5 VDC
11	I/O RTN
12	FEEDBACK ENCODER CHANNEL A (+)
13	FEEDBACK ENCODER CHANNEL A (-)
14	FEEDBACK ENCODER CHANNEL B (+)
15	FEEDBACK ENCODER CHANNEL B (-)

Connection to PE Ground

TB1-3 must be connected to Protective Earth ground (this pin is marked with the PE symbol). The connection at the Protective Earth ground end must be hard wired (not utilize pluggable connections)

A ground fault detector (RCD) cannot be depended upon for safety.

Specifications

Output Power Specifications

	<u>PC8x2</u>	<u>PC8x3</u>	<u>PC8x4</u>
Peak Output Current (RMS)¹ 5 seconds, (0 to 40° C) Ambient	5.3 A _{RMS}	10.6 A _{RMS}	21.2 A _{RMS}
Continuous Output Current (RMS)² Convection (0 to 40°C) Ambient	2.7 A _{RMS}	3.6 A _{RMS}	7.1 A _{RMS}
Forced Air (0 to 40°C) Ambient ³	N/A	5.3 A _{RMS}	10.6 A _{RMS}
Peak Output Power Idealized Max (rectangular torque vs. speed) Drive & Motor System Output Power	2.25 kW	4.5 kW	9.0 kW
240 VAC three phase ⁴ (5 seconds)	1.35 to 1.58 kW	2.7 to 3.15 kW	5.4 to 6.3 kW
240 VAC single phase (1 second)	1.25 kW	2.5 kW	5.0 kW
120 VAC single phase (1 second)	0.63 kW	1.25 kW	2.5 kW
Continuous Output Power Drive & Motor System at Convection Ambient 240 VAC three phase	1.1 kW	1.5 kW	3.0 kW
240 VAC single phase*	1.1 kW	1.5 kW	2.0 kW*
240 VAC single phase*	550 W	750 W	1.0 kW*
RMS Line Current at Continuous Output Power Convection Ambient 240 VAC three Phase	4.5 A	6 A	12 A
240 VAC single Phase*	9 A	12 A	16 A*
120 VAC single Phase*	9 A	12 A	16 A*
Power Stage Efficiency at Pcont	98%	98%	98%
Shunt Regulator Power Peak Power (500 ms)	12.8 kW	12.8 kW	12.8 kW
Continuous Power**	800 W	800 W	800 W
Maximum External RegenDuty Cycle	6%	6%	6%
Bus Capacitance Energy Absorption From 320V Nominal Bus	20 J	30 J	40 J
Output Current Ripple Freq f_s	20 kHz	20 kHz	16 kHz
Minimum Motor Inductance I-l	4.0 mH	2.0 mH	1.25 mH
Maximum Motor Inductance I-l	4 H	2 H	1 H
Maximum Motor Power Cable Length	-----50 m/164ft-----		

*Single phase operation of the PC8x4 requires derating of the continuous output power to avoid excessive line and front end currents.

** See External Regen section for additional information.

¹To convert A_{RMS} to A (0-pk) multiply A_{RMS} * 1.41. Peak current (5 sec): PC832 = 7.5A (0-pk), PC833 = 15A (0-pk), PC834 = 30A (0-pk)

²Above 40° C ambient, linearly derate so that 50°C rating = 0.67*40° C rating.

³Forced air requires 3.6" x 1" fan mounted 2" below the drive.

⁴Varies with the motor. Max peak output power with most motors is between 60% to 70% of Idealized Electrical Max

Input Power Specifications

The drive is capable of direct-line operation. All units are fully- isolated and do not require external isolation transformers. Inrush current on the connection to the line is internally-limited to a safe level for the drive. There are no voltage selection or ranging switches required to operate within the specified voltage input ranges. It is your responsibility to supply appropriate fuses or circuit breakers in the TB1 AC Power motor power lines to comply with local electrical codes.

The control input power required should be between 15 and 25 watts. The AC input motor power depends on output power and the losses in the power stage. The control power input has a single UL/CSA rated fuse in line with one of the AC line inputs.

PC800 Control Power Supply

Input Voltage Range	85 to 265 VAC, 47 - 440 Hz single phase or 130 to 370 VDC
Ride Through Time for AC Line Drop	90 VAC 50 Hz >0.7 50 Hz cycle 120 VAC 60 Hz >2.1 60 Hz cycles 240 VAC 60 Hz >13.3 60 Hz cycles

PC830 Motor AC Power Supply

Model Number	Voltage Range	Phases	Transformer Suggested kVA	Maximum AC Line* kVA
PC8x2	90 - 265 VAC	1 or 3	1.5 to 3 kVA	100 kVA
PC8x3	90-265 VAC	1 or 3	2 to 4 kVA	100 kVA
PC8x4	180-265 VAC	3	3 to 6 kVA	250 kVA

*Maximum AC Line is specified to limit the line surges coupled to the drive.

Bus Voltage (nominal, standard drive)

240 VAC Three Phase Input	320 VDC
120 VAC Single Phase Input	155 VDC

PC830 Inrush Current & Fusing

Model Number	Inrush Peak Current	Inrush PulseWidth	Fuse Type	Manufacturer, Part Number
PC8x2	300 A 0-p	1.0 ms	10 A 250 V Time Delay	Bussmann, MDA-10
PC8x3	300 A 0-p	1.5 ms	20 A 250 V Time Delay	Bussmann, MDA-20
PC8x4	300 A 0-p	2 ms	30 A 250 V Slo-Blo	Littlefuse, FLM 30

Environmental

Storage Temperature	-40° C to 70° C
Humidity, non-condensing	10% to 90%
Altitude	1500 m (5000 feet)

Diagnostics and Protection Circuits

The drive is fully protected against “normal” abuse and has two LEDs on the front panel to indicate drive status. The servo drive has the following specific protections:

- Output motor short circuit protection line-to-line and line-to-neutral.
- Interface to Danaher Motion's Pacific Scientific standard motor PTC or a normally closed thermostat to sense motor over temperature.
- Internal monitoring of the power stage heat sink temperature for drive over temperature.
- Bus over voltage detection.
- Bus under voltage fault with adjustable threshold.
- Incorporating the measured heat sink temperature there is an excessive current I*t fault. This fault limits the peak current time and intelligently changes the continuous current fault trip dependent on the measured heat sink temperature to limit the continuous output current.
- Control voltage under voltage detection.
- The user +5 V output is short circuit to I/O RTN protected.
- The user +24 V output is short circuit protected.
- All control outputs are short circuit to I/O RTN protected.
- When a drive is powered up without valid parameters the power stage cannot be enabled and no damage occurs to the drive.

Fault Generation

The following sequence occurs when the protection circuits generate a fault. The fault source is latched, the output stage is disabled, the Fault mappable output function is activated, and the LED indicates the appropriate fault code. Faults are cleared by activating the Fault Reset input or by turning the 120/240 VAC Control Power OFF and then ON again.

Drive Status LEDs

See the following table for a detailed list of drive status LED codes.

Drive Status	Fault LED (Red)	Power LED (Green)
Faulted	If FaultCode < 6, Blinking If FaultCode ≥ 6, On	On
Enabled	Off	On
Disabled	Off	Blinking
Unconfigured	Blinking	Blinking
Unplugged	Off	Off



If FaultCode < 6, the red LED blinks the faultcode at a frequency of 1 Hz (on and off in 1 sec). Then, it is off for 2 seconds before blinking the sequence again.

Fault LED Troubleshooting

A table of faults and their possible causes is listed below. If FaultCode < 6 , the Fault LED blinks the value of FaultCode. For example, if FaultCode = 2, the Fault LED blinks twice. If Faultcode = 6 the Fault LED is ON.

FaultCode	Possible Cause
1	Loose or open circuit wiring to the resolver feedback connector J3.
	Actual motor speed exceeded $1.5 * (\text{Max Of VelLmtLo or VelLmtHi})$ or 21,038 rpm which is the over speed trip level.
	For Encoder velocity feedback (RemoteFB = 2) check that EnCln is set properly.
2	Loose or open circuit wiring to motor PTC thermal sensor (J3-8, J3-9).
	High ambient temperature at motor.
	Insufficient motor heat sinking from motor mounting.
	Operating above the motor's continuous current rating.
3	Short circuited wiring on the output (J2-25).
4	Mechanically jammed motor.
	Motion profile accelerations too high.
	Machine load on the motor increased by a friction.
	Problem with wiring between drive and motor yielding improper motion.
	Drive and/or motor under sized for application.
Note: See <i>HSTemp</i> , <i>ItFilt</i> , and <i>ItF0</i> for information on measuring thermal margin in an application.	
5	Motor power wiring (TB1-4, 5, or 6) short circuit line-to-ground/neutral.
	Motor power cable length is enough longer than the data sheet specification to cause excessive motor line to earth ground/neutral capacitance.
	Internal motor winding short circuit.
	Insufficient motor inductance causing output over current faults.
	KIP or KII improperly set causing excessive output current overshoots.

Fault LED ON

The Fault LED is ON when FaultCode \geq 6.

FaultCode	Possible Cause
6	Insufficient control AC voltage on TB1-1 to TB1-2.
	External short on signal connector.
	Internal drive failure.
7	Not Assigned.
9	Disconnected external regeneration resistor on TB1.
	External regeneration resistor ohmage too large yielding Bus OverVoltage fault.
	External regeneration resistor short circuit.
	Motor AC power input voltage too high.
10	Not Assigned.
11	Check the measured bus voltage VBus and the fault threshold VBusThresh to make sure they are consistent.
12	Ambient temperature is below drive specification. Drive's internal temperature sensor has a wiring problem.
13	Encoder Alignment failure. See ExtFault for additional information.
14	Not Assigned.
15	Attempt to upgrade the drive's software will not work. Contact factory for upgrade details.
	Resolver wiring error. Remove J2 and J3 connectors. Turn AC power OFF and then ON again.
	If FaultCode = 2, then correct resolver excitation wiring.
	Internal failure. Return to factory for repair.
16	Unconfigured drive (Red and Green LEDs blinking after power up) was fully configured with the drive motor power enable active. This fault can be reset or the control AC power turned OFF and then ON again to get the drive-motor operating.
17	The AInNull function was re-activated too soon after going inactive. This can be caused by switch bounce on the input pin mapped to activate AInNull.
18	The motor is either stalled or partially jammed.
	The value for PosErrorMax is set too sensitive for the loop tuning and commanded motion profiles.
19	Glitch while last saving the NV parameters. Corrupted NV memory contents. Hardware problem with the NV memory. Re-Download parameters to restore drive operation.
20	Initialization Failure. See ExtFault for additional information.
21	High drive ambient temperature. Restriction of cooling air due to insufficient space around unit.
	Operating above the drive's continuous current rating.
	Note: See <i>HSTemp</i> , <i>ItFilt</i> , and <i>ItF0</i> for information on measuring thermal margin in an application.

Other Tools

MA830	PC830 User Manual. This manual is available from Danaher Motion or downloadable from our website at www.danahermotion.com .
830Tools	Configuration software for the PC830. This can be ordered from Danaher Motion or downloaded from our website at www.danahermotion.com .

Contact the Factory

There are no user serviceable parts in the PC830. If your drive fails, contact the factory for a Return Materials Authorization (RMA) number. Customer Service can be reached 8 a.m. to 5 p.m. EST at 540-633-3400.