



# S200 High Performance Compact Brushless Servo Drives

*Base and SynqNet® Units  
Control Logic Version 3.0 or Higher*

**Reference Manual  
M-SM-200-01  
Revision H**



**KOLLMORGEN®**

*Because Motion Matters™*

## Revision History

<b>Date</b>	<b>Issue</b>	<b>Description</b>
05/2004	-	Initial Release
03/2006	A	Addition of SynqNet information
10/2007	B	Add S21260 12/30 Arms base unit
2/2008	C	Add S22460 24/48 Arms base unit
4/2012	D	Update branding to Kollmorgen
5/2014	E	Update ARMS S20350
4/2019	F	Update RJ45 mating connectors
12/2021	G	Update for HW Rev C updated products in Appendix H
6/2022	H	Update S21260 for HW Rev C updated products in Appendix H

© 2006, 2007, 2008, 2021, 2022 Kollmorgen - All rights reserved.  
Printed in the United States of America.

## NOTICE:

Kollmorgen® is a registered trademark of Altra Industrial Motion. Kollmorgen makes every attempt to ensure accuracy and reliability of the specifications in this publication. Specifications are subject to change without notice. Kollmorgen provides this information "AS IS" and disclaims all warranties, express or implied, including, but not limited to, implied warranties of merchantability and fitness for a particular purpose. It is the responsibility of the product user to determine the suitability of this product for a specific application.

## Safety Symbols



**Warnings - alert users to potential physical danger or harm. Failure to follow warning notices could result in personal injury or death.**



**Cautions - direct attention to general precautions. Personal injury and/or equipment damage could result if precautions are ignored.**



**Notes - highlight information critical to your understanding or use of the product.**

# Table of Contents

<b>1</b>	<b>S200 Series Drives</b> .....	<b>1</b>
1.1	Manual Scope .....	1
1.2	Model Number.....	2
1.3	Drive Model Numbers and Descriptions .....	2
<b>2</b>	<b>Before You Begin</b> .....	<b>3</b>
2.1	Safety .....	3
2.2	Unpacking and Inspecting.....	3
<b>3</b>	<b>Specifications</b> .....	<b>4</b>
3.1	Drive Family Power.....	4
3.2	AC Input Drives - Control and Power.....	6
3.2.1	AC Control Power Supply .....	6
3.2.2	AC Motor Power Supply.....	6
3.2.3	AC Bus Voltage and Faults.....	6
3.2.4	AC Motor Power Inrush Current & Fusing .....	6
3.2.5	AC Control Power Inrush Current & Fusing.....	7
3.2.6	AC Power On Delay.....	7
3.3	DC Input Drives - Control and Power.....	7
3.3.1	DC Control Power Supply .....	7
3.3.2	DC Bus Voltage and Faults.....	7
3.3.3	DC Control Power On Delay.....	7
3.4	Motor Current Control .....	8
3.4.1	Current Loop Bandwidth .....	8
3.4.2	Offset Current .....	8
3.5	Velocity Loop.....	9
3.5.1	Velocity Loop Compensation .....	9
3.6	Command I/O.....	10
3.6.1	Analog Command .....	10
3.6.2	Analog Output (DacMon) .....	10
3.6.3	HSINP – Step/PWM Command .....	10
3.6.4	MSINP - Direction Command .....	11
3.6.5	Quadrature Input.....	11
3.6.6	General Purpose Inputs .....	11
3.6.7	General Purpose Outputs .....	11
3.6.8	Quadrature Outputs .....	11
3.7	Mechanical.....	12
3.8	Environmental .....	12
3.9	Smart Feedback Device (SFD).....	13
3.9.1	Position Signal .....	13
3.9.2	Velocity Signal .....	13
3.9.3	Emulated Encoder Output Signals.....	14
3.9.4	General SFD Specifications.....	14
<b>4</b>	<b>Quick Start Guides</b> .....	<b>15</b>
4.1	S200 Base Unit Drive—Quick Start .....	15
4.1.1	S200 Tools Software Installation .....	15
4.1.2	Hardware Setup .....	16
4.1.3	S200 Tools Communications Wizard.....	17
4.1.4	Motor Feedback Configuration .....	19

4.1.5	Save Options .....	19
4.2	<i>S200 SynqNet Drive—Quick Start</i> .....	20
4.2.1	MDK and SynqNet Controller Installation .....	20
4.2.2	S200 Tools Software Installation .....	20
4.2.3	Hardware Setup .....	21
4.2.4	S200 Tools Communication Wizard .....	23
4.2.5	SynqNet Configuration .....	26
4.2.6	Motor Feedback Configuration .....	27
4.2.7	Save Options .....	28
<b>5</b>	<b>Mounting the Drive .....</b>	<b>29</b>
5.1	<i>Mounting Dimensions</i> .....	29
5.2	<i>Mechanical Outline Drawings</i> .....	31
5.2.1	Base AC Drive (S20260-, S20360-, S20660-VTS) .....	31
5.2.2	Base AC Drive (S21260-VTS) .....	32
5.2.3	Base AC Drive (S22460-VTS) .....	33
5.2.4	Base DC Drive (S20330-, S20630-VTS) .....	34
5.2.5	SynqNet AC Drive (S20260-, S20360-, S20660-SRS) .....	35
5.2.6	SynqNet DC Drive (S20330-, S20630-SRS) .....	36
<b>6</b>	<b>Wiring the Drive .....</b>	<b>37</b>
6.1	<i>AC Input Drive Wiring</i> .....	37
6.1.1	AC Drive (S20260-, S20360-, S20660-VTS) .....	37
6.1.2	AC Drive (S21260-, S22460-VTS) .....	38
6.2	<i>J1 – AC Input Drive Power</i> .....	39
6.3	<i>DC Input Drive Wiring</i> .....	42
6.4	<i>J1 – DC Input Drive Power</i> .....	43
6.4.1	DC Power Supply Requirements .....	44
6.4.2	Bus Voltage .....	45
6.4.3	Control Voltage .....	45
6.4.4	Grounding .....	46
6.4.5	Bus Capacitance .....	46
6.4.6	Bus Switching and Fusing .....	46
6.5	<i>J2 – Motor Power Connector</i> .....	47
6.6	<i>J3 – Feedback Connector</i> .....	48
6.7	<i>J4 – Command I/O Connector</i> .....	49
6.7.1	General Purpose Inputs .....	49
6.7.2	General Purpose Outputs .....	53
6.7.3	High Speed Input .....	55
6.7.4	SFD BAT+ .....	56
6.7.5	DAC Monitors .....	57
6.7.6	Encoder Outputs/Inputs .....	57
6.7.7	Analog Command Input .....	59
6.8	<i>J5 – Serial Port Connector</i> .....	60
6.8.2	Serial Interface Specification .....	61
6.8.3	RS-232 Wiring .....	61
6.9	<i>SynqNet Option Card Wiring</i> .....	62
6.10	<i>J11 – SynqNet IN Port Connector</i> .....	63
6.10.1	SynqNet LEDs .....	63
6.11	<i>J12 – SynqNet OUT Port Connector</i> .....	64
6.11.1	SynqNet LEDs .....	64

6.12	<i>J13 – Discrete I/O Connector</i> .....	65
6.12.1	<i>J13 – Discrete I/O Connection Schematic</i> .....	66
6.13	<i>J14 – AUX FB Connector</i> .....	67
6.13.1	<i>Auxiliary Feedback Device Port</i> .....	67
6.13.2	<i>Auxiliary Feedback Sin-Cos Interpolation Scaling</i> .....	68
<b>7</b>	<b>Basic Configuration</b> .....	<b>69</b>
7.1	<i>Switch Settings</i> .....	69
7.1.1	<i>S2 - DIP Setup Switch</i> .....	69
7.1.2	<i>S1 - Rotary Setup Switch</i> .....	70
7.1.3	<i>S11, S12 - Rotary SynqNet ID Switches</i> .....	71
7.2	<i>Configuring for Brush Motors</i> .....	73
7.3	<i>Configuring with 6-Step (Hall) Feedback</i> .....	74
7.3.1	<i>6-Step Feedback Wiring</i> .....	74
7.3.2	<i>6-Step Torque/Current Mode</i> .....	75
7.3.3	<i>6-Step Velocity Mode</i> .....	76
7.4	<i>Configuring with SFD Feedback</i> .....	77
7.4.1	<i>SFD Motor Parameters</i> .....	77
7.4.2	<i>SFD Torque/Current Mode</i> .....	78
7.4.3	<i>SFD Velocity Mode</i> .....	79
7.4.4	<i>SFD Position Mode</i> .....	80
7.5	<i>Reversing Motion Direction</i> .....	81
<b>8</b>	<b>Advanced Configuration</b> .....	<b>82</b>
8.1	<i>Base Drive Torque/Velocity Control Block Diagram</i> .....	83
8.2	<i>Base Drive Position Control Block Diagram</i> .....	84
8.3	<i>SynqNet Drive Torque Control Block Diagram</i> .....	85
8.4	<i>SynqNet Drive Velocity Control Block Diagram</i> .....	86
8.5	<i>Parameters and Variables</i> .....	87
8.5.1	<i>Parameter and Variable Storage</i> .....	87
8.5.2	<i>Model Dependent Scale Factors</i> .....	88
8.5.3	<i>Read/Write NV Parameters</i> .....	89
8.5.4	<i>Status And Control Variables</i> .....	98
<b>9</b>	<b>SynqNet Configuration</b> .....	<b>103</b>
9.1	<i>Drive FPGA Table</i> .....	103
9.2	<i>Drive Monitor</i> .....	105
9.2.1	<i>Drive Monitor Table</i> .....	105
9.2.2	<i>Monitoring Real-time Data from Drive</i> .....	105
9.3	<i>Accessing Drive Parameters over SynqNet</i> .....	106
9.3.1	<i>Introduction</i> .....	106
9.3.2	<i>Memory Operations on Drive Parameters</i> .....	106
9.3.3	<i>Accessing Individual Parameters</i> .....	107
9.3.4	<i>Accessing an Entire Parameter Set</i> .....	108
<b>10</b>	<b>Accessories, Connector Kits, and Cables</b> .....	<b>111</b>
10.1	<i>Accessories</i> .....	111
10.2	<i>Connector Kits</i> .....	111
10.3	<i>Cables</i> .....	112
<b>11</b>	<b>Diagnostics and Troubleshooting</b> .....	<b>113</b>
11.1	<i>Drive Fault Codes</i> .....	114
11.2	<i>Diagnostics</i> .....	115

11.2.1 Fault Generation .....	118
<b>Appendix A – DC Power Supply Design.....</b>	<b>119</b>
A.1 Design .....	119
A.1.1 Single Power Supply Operation .....	119
A.1.2 Main Supply Output Capacitance (J1-3 to J1-2).....	121
A.2 Two Power Supply Operation .....	125
A.2.1 Control Supply (J1-1 to J1-2).....	125
A.3 Multi-Axis Considerations.....	125
A.4 Bus Energy & Power Numerical Examples.....	126
A.4.1 Min. External Bus Capacitance.....	126
A.4.2 Energy from Acceleration Time .....	126
A.4.3 Capacitor Energy Absorb/Deliver .....	127
A.4.4 Bus DC Input Power .....	127
<b>Appendix B – Cables .....</b>	<b>128</b>
B.1 Long Cables .....	128
B.2 Custom Composite Cables .....	129
<b>Appendix C – Kollmorgen Linear Motor Wiring.....</b>	<b>131</b>
<b>Appendix D – Process to Setup Non-Kollmorgen Motors.....</b>	<b>132</b>
D.1 Detailed Drive Motor Wiring Discovery Procedure .....	133
<b>Appendix E – Voltage Sag Standard – Semi F47, F42 .....</b>	<b>136</b>
<b>Appendix F – Using a Voltage Doubler Mode Drive .....</b>	<b>137</b>
F.1 S2xx50 AC Line Voltage Doubling Drive Power Specifications.....	138
<b>Appendix G – Regulatory Information.....</b>	<b>139</b>
G.1 Conformance Requirements .....	139
G.2 CE Approval .....	139
G.2 CE EMC Compliance .....	139
G.2.1. CE Test Setup.....	140
G.2.2 CE Test Setup.....	141
G.2.3 Declaration of Conformity .....	141
G.3 Installation and Commissioning .....	143
G.4 Safety requirements .....	143
G.5 European Compliance.....	143
G.6 Low Voltage Directive and EN50178 .....	144
G.7 UL and cUL Conformance.....	145
G.8 Additional Safety Precautions .....	146
G.9 EMC Compliance with EN61800-3 .....	147
G.10 AC Mains Conducted Emissions.....	148
G.11 Regen Resistor .....	149
G.12 Additional EMC Information Sources .....	150
G.13 Customer Support .....	150
<b>Appendix H – Hardware and Regulatory Update .....</b>	<b>151</b>
H.1 Introduction.....	151
H.2 Base Unit FPGA Control Logic Update.....	152
H.3 Functionality Enhancements.....	154
H.3.1 New Parameters for Control Logic 4.xx .....	154
H.3.2 Procedure to change FbType .....	156
H.3.3 J3 Feedback Pinouts.....	159

<i>H.3.4 Procedure to change FilterType.....</i>	<i>160</i>
<i>H.3.5 BiQuad Filter Feature.....</i>	<i>161</i>
<i>H.3.5.1 S200 Tools Biq Coeffs Pane.....</i>	<i>161</i>
<i>H.4 Regulatory Approval Changes.....</i>	<i>164</i>
<i>H.5 Agency Ratings and Fuse Recommendations.....</i>	<i>165</i>
<i>H.6 CE Regulatory Certification Details.....</i>	<i>166</i>
<i>H.7 UL Criteria of Acceptance.....</i>	<i>167</i>

# 1 S200 SERIES DRIVES

## Industry-Leading Performance In A Small Package

Kollmorgen's S200 brushless servo drives puts high performance servo technology into a full power range family with dc input and ac input family members. Particularly for lower power applications the S200 family provides a higher performing more robust option than was previously possible without having to compromise on reliability or package size. Coupling an S200 drive with Kollmorgen's AKM servomotor provides a complete servo control solution designed to excel in applications such as semiconductor fabrication, electronic assembly, packaging, medical, and woodworking equipment among others. Kollmorgen's S200 servo drives are the first all-digital industrial drives with a velocity loop bandwidth up to 800 Hz, offering unmatched system throughput and simplified tuning. High resolution (24 bit) feedback and high performance 3-5 kHz current loop bandwidth provide smooth motion and rapid start and stop action to optimize machine performance. Smart feedback and industry leading high bandwidth deliver fast and accurate "plug and play" commissioning by eliminating the need for servo loop tuning in most applications.

Base S200 servo drives come standard with torque or velocity control, as well as with factory options that support the SynqNet motion network or add pre-settable Indexing with CANopen communications. The factory option cards also add interfaces to additional motor feedback devices such as Comcoder, 1 Vp-p Sin-Cos, EnDat 2.1, and EnDat 2.2 running in 2.1 compatibility mode. The option card EnDat interface accommodates single and multi-turn absolute rotary or incremental and absolute linear encoders. The drives operate with AC (120/240 VAC) or DC (20-90 VDC) power sources and have current ratings from 1.5 ARMS continuous to 48 ARMS peak. Their compact footprint ranges from 1.1 in (28.7 mm) wide and 6.0 in (152.4 mm) tall to 3.8 in (94.6 mm) wide and 6.39 in (213 mm) tall with depths ranging from 3.9 in (100.8 mm) to 7.57 in (192.4 mm), allow them to fit into tight spaces. They are UL 508C recognized, CE marked, and conform to EN50178 and EN61800-3 standards.

The original S200 family included lead in the soldering. Units manufactured after November 2007 are fully compliant with the EU RoHS environmental directive. The RoHS units also all have control logic version 3.0A or newer. See parameter **VerLW**.

Separate "Keep Alive" control power input allows communications and diagnostics to continue during emergency stop conditions with no power to the motor. It also allows rapid recovery from emergency stops. Optically isolated inputs and outputs, positive locking connectors, and full fault protection promise long machine life and immunity to accidental damage. The single motor power or feedback cable option simplifies connectivity. All connectors and LED status indicators are easily accessible from the front of the drive.

**NOTE:** In late 2021 HW Rev C S200 products were released to production. HW Rev C products are form, fit, and function equivalent to earlier generation products except for optional new features documented in Appendix H. The main changes are UL 68100-5-1 approval and optional enhanced features such as supporting more feedback devices in the base unit on connector J3 and having Biquad compensation filter options in the velocity loop.

## 1.1 MANUAL SCOPE

This manual documents the S200 base drives and the S200 drives with the SynqNet motion bus option card installed. See the separate **S200 Position Node User's Guide** and **S200 Position Node Installation Guide** part numbers M-SS-S2B-11 and M-SS-S2A-11 respectively for S200 drives equipped with the Position Node option card.



## 1.2 MODEL NUMBER

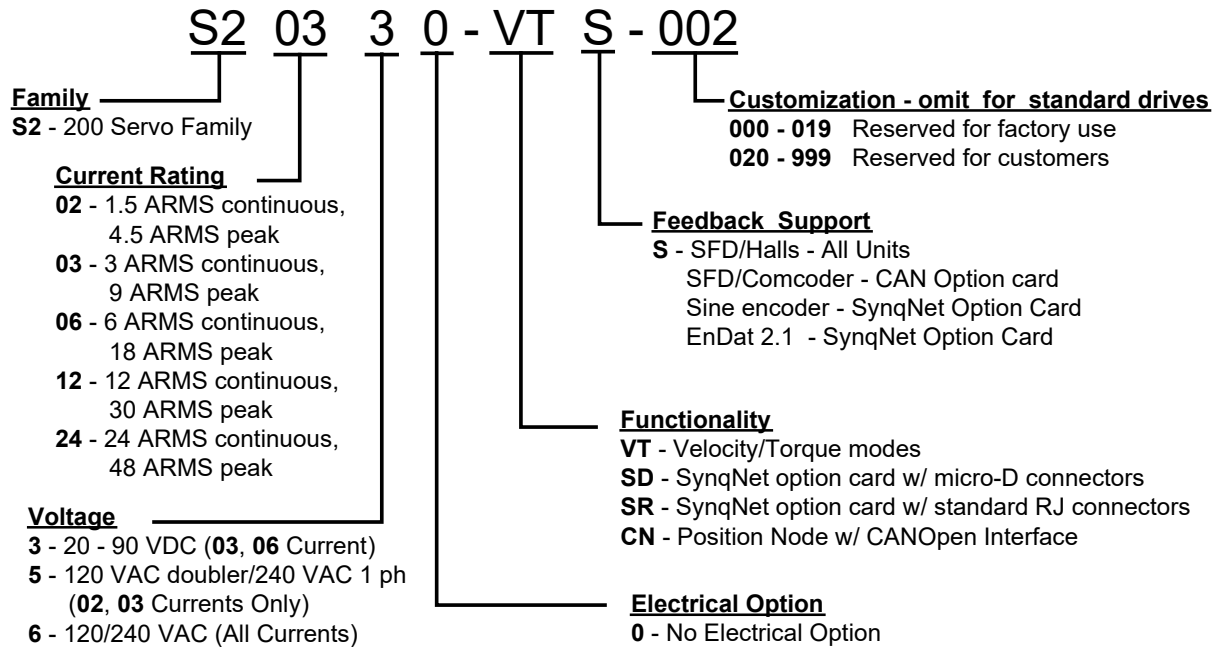

## 1.3 DRIVE MODEL NUMBERS AND DESCRIPTIONS

Here is a list of the various S200 Series Drives.

- **VTS** – Analog Velocity/Torque Base Drive
- **SDS** – SynqNet option card with Micro-D connectors
- **SRS** – SynqNet option card with RJ-45 connectors
- **CNS** – CAN/Indexer option card (**Not documented in this manual**)

AC Drive	Description
S20260-VTS	S200 120/240 VAC, 1/3-phase, 1.5/4.5 ARMS Base Unit
S20360-VTS	S200 120/240 VAC, 1/3-phase, 3/9 ARMS Base Unit
S20250-VTS	S200 120 VAC, doubler/240 VAC 1 ph 1.5/4.5 ARMS Base Unit
S20350-VTS	S200 120 VAC, doubler/240 VAC 1 ph 3/9 ARMS Base Unit
S20660-VTS	S200 120/240 VAC, 1/3-phase, 6/18 ARMS Base Unit
S21260-VTS	S200 240 VAC, 1/3-phase, 12/30 ARMS Base Unit
S22460-VTS	S200 240 VAC, 3-phase, 24/48 ARMS Base Unit
S2xx0-SRS	One of the above drives with optional SynqNet with RJ-45 connectors
S2xx0-SDS	One of the above drives with optional SynqNet with Micro-D connectors

DC Drive	Description
S20330-VTS	S200 90 VDC, 3/9 ARMS Base Unit
S20630-VTS	S200 90 VDC, 6/18 ARMS Base Unit
S2xx30-SRS	One of the above drives with optional SynqNet with RJ-45 connectors
S2xx30-SDS	One of the above drives with optional SynqNet with Micro-D connectors

## 2 BEFORE YOU BEGIN

### 2.1 SAFETY



**READ these instructions before connecting power. Damage can result from MISWIRING at the power terminals.**

**DANGEROUS voltages are present on power input and motor output terminals.**

Only qualified personnel are permitted to transport, assemble, commission, and maintain this equipment. Properly qualified personnel are persons who are familiar with the transport, assembly, installation, commissioning and operation of motors, and who have the appropriate qualifications for their jobs.

Read all available documentation before assembling and using. Incorrect handling of products described in this manual can result in injury and damage to people and/or machinery. Strictly adhere to the technical information regarding installation requirements.

- Keep all covers and cabinet doors shut during operation.
- Be aware that during operation, the product has electrically charged components and hot surfaces. Control and power cables can carry a high voltage, even when the motor is not rotating.
- Never disconnect or connect the product while the power source is energized.
- After removing the power source from the equipment, wait at least 5 minutes before touching or disconnecting sections of the equipment that normally carry electrical charges (e.g., capacitors, contacts, screw connections). To be safe, measure the electrical contact points to each other and to electrical safety earth with a meter before touching the equipment.

### 2.2 UNPACKING AND INSPECTING

Open the box and remove all the contents. Check to ensure there is no visible damage to any of the equipment.



**CAUTION**

**Use proper procedures when handling electronic components to avoid damage to equipment.**



**CAUTION**

**Remove all packing material and equipment from the shipping container. Be aware that some connector kits and other equipment pieces may be quite small and can be accidentally discarded. Do not dispose of shipping materials until the packing list has been checked.**



**NOTE**

**Upon receipt of the equipment, inspect components to ensure that no damage has occurred in shipment. If damage is detected, notify the carrier immediately. Check all shipping material for connector kits, documentation, diskettes, CD-ROM, or other small pieces of equipment.**

### 3 SPECIFICATIONS



**NOTE** *Unless otherwise specified, the specifications are worse-case limits and apply over the specified operating ambient temperature and over the specified operating line voltage.*

#### 3.1 DRIVE FAMILY POWER

	240 Vac Input					20-90 Vdc Input	
	S20260	S20360	S20660	S21260	S22460	S20330	S20630
<b>Peak Output Current (RMS)<sup>1</sup></b>							
(0 to 50°C) Amb ( $A_{RMS}$ )	4.5	9.0	18.0	30.0	48	9.0	18.0
<b>Minimum Peak Current Time</b>							
Start from 0 $A_{RMS}$ (sec)	3.0						
<b>Continuous Output Current Convection<sup>2</sup></b>							
0 to 30° C amb ( $A_{RMS}$ )	2.3	4.5	9.0	15.0	30.0	4.5	7.5
40° C amb ( $A_{RMS}$ )	1.5	3.0	6.0	12.0	24.0	3.0	6.0
50° C amb ( $A_{RMS}$ )	1.0	2.0	4.0	8.0	16.0	2.3	4.5
<b>Peak Output Power (1 sec)</b>							
240 Vac (VA) 3 Phase	1500	3000	6000	10000	16000	-	-
240 Vac (VA) 1 Phase	1400	2600	5000	8000	-	-	-
120 Vac (VA) 1 Phase	700	1300	2500	-	-	-	-
75 Vdc (VA)	-	-	-	-	-	750	1500
<b>Drive Continuous Output Power</b>							
240 Vac 3 Phase (W)	600	1100	2000	4000	8000	-	-
240 Vac 1 Phase (W)	500	900	1500	2500	3000	-	-
120 Vac 1 Phase (W)	250 <sup>6</sup>	450 <sup>6</sup>	750	-	-	-	-
75 Vdc (W)	-	-	-	-	-	250	500
<b>Continuous Motor Shaft Power @3000 RPM (Nominal Bus -10% 3 Phase/DC)</b>							
0 to 30° C amb (W) 3-ph	300	750	1500	2500	5000	180	315
0 to 30° C amb (W) 1-ph	300	750	1300	2200	2500	-	-
40° C amb (W)	200	500	1000	2000	4000	125	250
<b>RMS Line Current at Continuous Output Power</b>							
240 Vac 3Phase ( $A_{RMS}$ )	2.7	5.0	9.0	16	24	-	-
240 Vac 1 Phase ( $A_{RMS}$ )	3.4	6.5	12 <sup>3</sup>	18 <sup>3</sup>	22 <sup>3</sup>	-	-
120 Vac 1 Phase ( $A_{RMS}$ )	3.4	6.5	12 <sup>3</sup>	-	-	-	-
<b>Maximum AC Line kVA (limits mains surges to drive)</b>							
AC Line kVA max	100			250		NA	
<b>+BUS Current With 75 VDC at Continuous Output Power</b>							
Average ( $A_{DC}$ )	NA					3.0	6.7
Inst. Peak ( $A_{Peak}$ )	NA					12.7	25.5
Power Stage Diss. at $I_{cont}$ , 40°C $P_{cont}$ (W) <sup>5</sup>	15	25	60	110	175	3	10
<b>Shunt Regulator</b>							
Peak Power kW (500 mSec)	4.4 @36Ω	6.4 @25Ω	10 @15Ω	10 @15Ω	15 @10Ω	NA	
Continuous Power (W)	440 @36Ω	640 @25Ω	1000 @15Ω	1500 @15Ω	2500 @10Ω		
Maximum Regen Duty Cycle (%)	10 @36Ω	10 @25Ω	10 @15Ω	15 @15Ω	15 @10Ω		
Regen Resistance (Ω)	25 – 50	25 – 50	12 – 50	8 – 50	8 – 50	NA	

	240 Vac Input					20-90 Vdc Input	
	S20260	S20360	S20660	S21260	S22460	S20330	S20630
<b>Bus Capacitance Energy Absorption (joules)</b>							
340 VDC Nominal BUS	15.5	15.5	20	45	60	-	
75 VDC BUS 4,000 $\mu$ f (75 to 80 VDC delta)	-	-	-	-		1.5	
Output Current Ripple Freq $f_s$ (kHz)	20	20	16	16	16	31.2	31.2
Minimum Motor Inductance L (mH)	5	2.5	1.5	0.9	0.6	-	-
At 75 VDC	-	-	-	-	-	0.4	0.2
Maximum Motor Inductance L (mH)	300	150	75	45	30	30	15
<b>Maximum Motor Power Cable Length<sup>4</sup></b>							
18 AWG cable (m)	50	50	25	NA	NA	50	25
14 AWG Cable (m)			50	50	NA	50	50
12 AWG Cable (m)					50		
10 AWG Cable (m)					50		
1	<p><b>Peak Output Current listed is for sine mode. In six-step mode, the peak output currents are scaled to give the same output torque as in sine mode with a pure sinusoidal Back EMF motor.</b></p> <p><b>To convert <math>A_{RMS}</math> to <math>A(0-pk)</math>, multiply <math>A_{RMS} * 1.414</math>.</b></p>						
2	<p><b>For intermediate ambient temperatures linearly derate between adjacent provided 0-30° C, 40° C, or 50° C ratings.</b></p> <p><b>At higher ambient temperatures (above 30° C) the mounting surface temperature must be thermally conductive enough to limit the mounting temperature to less than 75° C. Typically this is only an issue for the S20360 unit. The other model's power dissipation is either too low to matter or they include integral fan cooling.</b></p>						
3	<p><b>Single phase operation of the S20660, S21260, S2460 requires derating of continuous output power to avoid excessive ac line front end currents.</b></p>						
4	<p><b>See Manual Appendix for voltage loss vs cable length. Also make sure that the cable amperage capacity exceeds the motor's continuous capability:</b></p> <p><b>AWG 18 7 Arms</b>  <b>AWG 14 15 Arms</b>  <b>AWG 12 20 Arms</b>  <b>AWG 10 30 Arms</b></p>						
5	<p><b>Total drive dissipation = power stage dissipation + control power. Control power adder is:</b></p> <p><b>Base unit only = 7W</b>  <b>Base plus option card = 10W</b></p>						
6	<p><b>For 120 Vac voltage doubled operation of S20250, S20350 units see Appendix D for power specifications.</b></p>						

## 3.2 AC INPUT DRIVES - CONTROL AND POWER

### 3.2.1 AC Control Power Supply

<b>Input Voltage Range (RMS)</b>	85 VAC to 265 VAC 1 phase 47 to 410 Hz Or 120 VDC to 375 VDC
<b>Ride Through Time for AC Line Drop</b>	85 VAC 60 Hz > 0.78 60 Hz cycles 120 VAC 60 Hz > 3.3 60 Hz cycles 240 VAC 60 Hz >18.5 60 Hz cycles

### 3.2.2 AC Motor Power Supply

<b>Input Voltage Range (RMS)</b>	S20260, S20360, S20660: 0 to 265 VAC S21260, S22460: 120 to 265 VAC
<b>Phases</b>	1 or 3
<b>Transformer Suggested KVA</b>	S20260: 1.5 to 2 kVA S20360: 2.0 to 3 kVA S20660: 3.0 to 5 kVA S21260: 4.5 to 6 kVA S22460: 8.0 to 12 kVA
<b>Maximum AC Line KVA<sup>1</sup></b>	S20260, S20360, S20660: 100 S21260, S22460: 250

<sup>1</sup> Maximum AC Line is specified to limit the mains surges to the drive.

### 3.2.3 AC Bus Voltage and Faults

<b>240 VAC Input Nominal Bus Voltage</b>	320 VDC
<b>120 VAC Input Nominal Bus Voltage</b>	155 VDC
<b>BUS Undervoltage Fault</b>	S20260, S20360, S20660 Default is None S21260, S22460: 150 VDC
<b>BUS Overvoltage (BusOV) Fault</b>	407 VDC $\pm$ 5%
<b>BUS Regen Voltage</b>	= 0.974*BusOV = 397 VDC Nominal

### 3.2.4 AC Motor Power Inrush Current & Fusing

	<b>S20260</b>	<b>S20360</b>	<b>S20660</b>	<b>S21260, S22460</b>
<b>Worse Case Inrush Peak Current at 240 VAC</b>	140 A 0-p	140 A 0-p	240 A 0-p	None, soft start
<b>Inrush pulse width</b>	1.5 ms	1.5 ms	2.0 ms	NA

<b>Recommended Fusing Line Inputs</b>	<b>S20260</b>	<b>S20360</b>	<b>S20660</b>	<b>S21260</b>	<b>S22460</b>
<b>Type – 250 VAC Time Delay Fuse</b>					
240 VAC 3 Phase (ARMS)	Bussmann FRN-R-5	Bussmann FRN-R-8	Bussmann FRN-R-15	Bussmann JKS-20	Bussmann JKS-30
240 VAC 1 Phase (ARMS)	Bussmann FRN-R-5	Bussmann FRN-R-10	Bussmann FRN-R-20	Bussmann JKS-30	Bussmann JKS-30
120 VAC 1 Phase (ARMS)	Bussmann FRN-R-5	Bussmann FRN-R-10	Bussmann FRN-R-20	NA	NA

### 3.2.5 AC Control Power Inrush Current & Fusing

<b>Worse Case Inrush Peak Current at 240 VAC</b>	10 A 0-p
<b>Inrush Pulse Width</b>	1.60 ms
<b>Fusing – Control Inputs</b>	Bussmann MDA – 1/2
<b>Nominal Power draw</b>	Base: 7 W With Option Card: 10 W

### 3.2.6 AC Power On Delay

<b>Control Power Applied to Drive Operational</b>	1.25 seconds
<b>Bus Power To Full Bus On Soft Start Units</b>	1.0 seconds

## 3.3 DC INPUT DRIVES - CONTROL AND POWER

### 3.3.1 DC Control Power Supply

<b>Control Voltage Range (VDC)</b> (J1-1 to J1-2)	+10 to +90
<b>Control Input Power (watts)<sup>1</sup></b>	2 to 8

<sup>1</sup>(20 watt min supply recommended) Refer to the DC Power Supply Section for detailed application information and requirements.

### 3.3.2 DC Bus Voltage and Faults

<b>+BUS Voltage Range (VDC) (J1-3 to J1-2)</b>	+20 to +90
<b>+BUS Undervoltage Fault</b>	+17 VDC nominal
<b>+BUS Overvoltage Fault</b>	+91 VDC nominal

### 3.3.3 DC Control Power On Delay

<b>Control Power Applied to Drive Operational</b>	1.5 seconds
---	-------------

### 3.4 MOTOR CURRENT CONTROL

Motor Phase Current Waveform	
(In Sine or six-step mode output torque = Motor $K_T \cdot \text{Drive } I_{FB}$ )	Pure sinusoidal or six-step, depending on feedback device
Motor Shaft Torque (Ignoring motor magnetic saturation)	
Peak (hot motor winding) Multiply $K_T$ by 1.06 for cold motor winding (AKM or PMA motors).	$K_T$ (N-m/ARMS)*Drive $I_{peak}$ (ARMS)
Instantaneous	$K_T$ (N-m/ARMS)*IFB (ARMS)

#### 3.4.1 Current Loop Bandwidth

Maximum Bandwidth	
AC Input Drive (kHz)	3
DC Input Drive (kHz)	5
Recommended Bandwidth	
AC Input Drive (kHz)	2
DC Input Drive (kHz)	3
SFD Auto Set (kHz) AC & DC	2
Bandwidth Variation For Fixed Motor L (% regulated independent of bus voltage)	$\pm 2.5$
Update Period ( $\mu$ s)	0.8
Recommended Max Motor Electrical Frequency (Hz)	
AC Input Drive (Hz)	600
DC Input Drive (Hz)	900

#### 3.4.2 Offset Current

Drive	Typical	Worst Case Over Temp
<b>S20250, S20260</b>	0.2% / 12 mA	0.5% / 32 mA
<b>S20350, S20360</b>	0.2% / 25 mA	0.5% / 64 mA
<b>S20660</b>	0.2% / 50 mA	0.5% / 128 mA
<b>S21260</b>	0.2% / 85 mA	0.5% / 210 mA
<b>S22460</b>	0.2% / 135 mA	0.5% / 340 mA
<b>S20330</b>	0.2% / 25 mA	0.5% / 64 mA
<b>S20630</b>	0.2% / 50 mA	0.5% / 128 mA

## 3.5 **VELOCITY LOOP**

<b>Maximum Stable Bandwidth (Hz with SFD)</b>	800
<b>Update Period (<math>\mu</math>s)</b>	0.8
<b>Range (rpm)</b>	0 to 18,300
<b>Command Resolution</b>	< 0.001 rpm analog 0.558 rpm serial

### 3.5.1 Velocity Loop Compensation

<b>KVP Range (Depends on Ipeak)</b>	0.00044 to 0.106 (Ipeak) (1/rad/sec)
<b>KVP Resolution (%)</b>	5
<b>KVI Range (Hz)</b>	0 or 0, 0.0238 to 753.9
<b>KVI Resolution (%)</b>	5
<b>ARF0 Range (Hz)</b>	1.518 to 96382
<b>ARF1 Range (Hz)</b>	1.518 to 96382



## 3.6 COMMAND I/O

### 3.6.1 Analog Command

<b>Maximum Differential Range (volts)</b>	±12.5
<b>Maximum Single Ended Range (volts)</b>	-12.5 to +16.0
<b>Full Scale Tolerance (%)</b>	
Worse Case	±3.5
Typical	±1
<b>Linearity (% Full Scale)</b>	< 0.1
<b>Monotonic to</b>	< 2 <sup>-16</sup> Full Scale
<b>S/N Ratio Referred to Full Scale (bits<sub>RMS</sub> nominal)</b>	
3000 Hz A/D Bandwidth	14
800 Hz A/D Bandwidth	16
25 Hz A/D Bandwidth	18
<b>Offset</b>	Adjustable to 0
<b>Maximum Unadjusted Offset (mV)</b>	50
<b>Offset Drift (µV/° C typ.)</b>	250
<b>CMRR</b>	> 30 dB at 60 Hz

### 3.6.2 Analog Output (DacMon)

<b>Resolution (bits)</b>	14
<b>Maximum Range (volts)</b>	0.5 – 4.5
<b>Full Scale Tolerance (%)</b>	
Worse Case	± 5
Typical	± 1
<b>Linearity (% Full Scale)</b>	<0.1
<b>Monotonic to</b>	< 2 <sup>-16</sup> Full Scale
<b>Offset (mV)</b>	< 100
<b>Offset Drift (µV/°C typ.)</b>	250

### 3.6.3 HSINP – Step/PWM Command

<b>HSINP - J4-10, J4-11</b>	
<b>Input Voltage (volts)</b>	3.0 – 6.0
<b>Input Current (mA)</b>	9.0 – 24.0
<b>Minimum Pulse Width (ns)</b>	250
<b>HSINP as Step Command</b>	
<b>Maximum Step Frequency (MHz)</b>	1.5
<b>HSINP as PWM Command</b>	
<b>PWM Frequency (kHz)</b>	0.25 to 250
<b>Pulse Width</b>	0 – 100% Duty Cycle
<b>Pulse Width Distortion (ns)</b>	250 maximum

### 3.6.4 MSINP - Direction Command

<b>MSINP - J4-5, J4-1</b>	
<b>Input Voltage (volts)</b>	± (4.0 - 30.0)
<b>Input Current (mA)</b>	0.65 - 6.7
<b>Direction Setup Time (µs)</b>	100
<b>Minimum Pulse Width (µs)</b>	200

### 3.6.5 Quadrature Input

<b>Quadrature Input CHA - J4-19, 20 CHB J4-21,22</b>	
<b>Type</b>	RS-422/RS-485
<b>Input Voltage</b>	Differential ± (0.2 to 12) volts Common Mode -7 to +12 volts
<b>Input Termination</b>	None internal to the drive.
<b>Maximum Line Frequency (kHz)</b>	625 (corresponds to 2.5 MHz quadrature pulse rate)

### 3.6.6 General Purpose Inputs

<b>DINP1, DINP2, DINP3 – J4-2, 3, 4</b>	
<b>Input Voltage (volts)</b> Referenced to DINPCOM (J4-5)	± (4.0 - 30.0)
<b>Input Current (mA)</b>	0.65 - 6.7
<b>Response Time</b>	1.0 ms

### 3.6.7 General Purpose Outputs

<b>DOUT1, DOUT2 – J4-6,7 and J4-8,9</b>	
<b>Maximum Output Voltage (volts)</b>	- 0.30 to 30.0
<b>Clamp Voltage (volts)</b>	33 V ± 6%
<b>Maximum Output Current</b>	50 mA
<b>On voltage (volts)</b>	1.0 V at 10 mA 1.2 V at 50 mA
<b>Response Time (ms)</b>	1.0

### 3.6.8 Quadrature Outputs

<b>Quadrature Output CHA- J4-19, 20 CH B- J4-21,22 CHZ- J4-17,18</b>	
<b>Type</b>	RS-422/RS-485
<b>Output Voltage (volts)</b>	5.0 V Differential Output - Unloaded
<b>Hysteresis</b>	1/2 Quadrature Count corresponding to 1/8 Encoder Line Count

### 3.7 MECHANICAL

S200 AC INPUT DRIVES					S200 DC INPUT DRIVES	
Base or w/ Option Card					Base Drive	w/ Option Card
S20260 S20360	S20660	S21260	S22460	S20630-VT S20330-VT	S20630-XX S20330-XX	
<b>Drive Dimensions</b>						
Drive Height (A)	175 mm 6.90 in		177 mm 6.97 in	213 mm 8.39 in	152.4 mm 6.00 in	
Drive Width (B)	54.8 mm 2.16 in	64.0 mm 2.52 in	76 mm 3.00 in	96.4 mm 3.80 in	28.7 mm 1.13 in	48.3 mm 1.90 in
Drive Depth <sup>1</sup> (C)	131.6mm 5.18 in		152 mm 5.98 in	192 mm 7.57 in	100.8 mm 3.97 in	
<b>Mounting Hardware</b>	M4 or #8	M4 or #8	M4 or #8	M4 or #8	M4 or #8	M4 or #8
<b>Drive Weight</b>	0.77 kg 1.69 lb, w/ option 0.84 kg 1.86 lb	0.82 kg 1.80 lb, w/ option 0.89 kg 1.97 lb	1.33 kg 2.93 lb, w/ option 1.40 kg 3.09 lb	2.56 kg 5.64 lb, w/ option 2.63 kg 5.80 lb	0.40 kg 0.88 lb	0.50 kg 1.10 lb

<sup>1</sup> Depth measurement is for drive only. Add approximately 50.8 mm (2 in) to accommodate mating connectors and wire bend radius.

### 3.8 ENVIRONMENTAL

<b>Operating Temperature (°C) – Full Rating</b>	0 to 40
<b>Operating Temperature (°C) – Derated Linearly Derate Continuous Current to specified 50 °C Rating</b>	40 to 50
<b>Pollution Degree</b>	2
<b>Storage Temperature (°C)</b>	-35 to 85
<b>Humidity (% non-condensing)</b>	10 to 90
<b>Altitude</b>	<1500 m (5000 feet)

## 3.9 SMART FEEDBACK DEVICE (SFD)

### 3.9.1 Position Signal

<b>Resolution/Rev (arc min)</b>	24 bits = 0.0013
<b>Repeatability (arc min RMS)</b>	$< \pm 2^{-19}$ Rev = $\pm 0.04$
<b>Noise</b>	
No Filtering (RMS)	$< 2^{-17}$ Rev RMS = 0.16 arc-min
150 Hz Single Pole Filtered (RMS)	$< 2^{-18}$ Rev RMS = 0.08 arc-min
10 Hz Single Pole Filtered (RMS)	$< 2^{-19}$ Rev RMS = 0.02 arc-min
<b>DC Offset Temperature Drift</b>	$< 2^{-18}$ Rev/ $^{\circ}$ C = 0.08 arc min/ $^{\circ}$ C
<b>Absolute Accuracy</b>	
AKM1 (arc min)	$\pm 2^{-10.3}$ Rev = $\pm 17$
AKM2 or 3, 4, 5, 6, 7 (arc min)	$\pm 2^{-11.1}$ Rev = $\pm 10$
<b>Communications Update Period (<math>\mu</math>s)</b>	51.2

### 3.9.2 Velocity Signal

<b>Resolution (rpm)</b>	$< 0.001$
<b>Quanta (rpm)</b>	0.07
<b>Noise</b>	
No Filtering (rpm RMS)	$< 4$
150 Hz Single Pole Filtered (rpm RMS)	$< 0.6$
10 Hz Single Pole Filtered (rpm RMS)	$< 0.06$
<b>DC Accuracy</b>	
Typical at 25 $^{\circ}$ C (%)	$\pm 0.01$
Worse case (%)	$\pm 0.05$
<b>Ripple</b>	
AKM1 (% p-p at 1200 rpm)	2.5
AKM2, 3, 4, 5, 6, 7 (% p-p at 1200 rpm)	1.5
<b>Offset (rpm)</b>	$< 0.0001$
<b>Communications Update Period (<math>\mu</math>s)</b>	51.2
<b>Hardware Interpolation Period (<math>\mu</math>s)</b>	0.1

### 3.9.3 Emulated Encoder Output Signals

<b>Available Resolutions (PPR)</b>	
<b>Selectable By Rotary Switch S1</b>	500, 512, 1000, 1024, 2000, 2048, 4096, 5000, 8192, 10000
<b>Programmable Values See EncOutPPR</b>	0 - 65535 integer
<b>Maximum Output Line Frequency (MHz)</b>	2.5
<b>Max Recommended Speed at 32768 PPR (rpm)</b>	2200
<b>Max Recommended Speed at 16384 PPR (rpm)</b>	4600
<b>Max Recommended Speed at 4096 PPR (rpm)</b>	18300
<b>Marker Pulse Width</b>	~ 2 Quadrature Pulses

### 3.9.4 General SFD Specifications

<b>-3 dB Bandwidth (Hz)</b>	> 2000
<b>-45° Phase Lag (Hz)</b>	> 1000
<b>Max Tracking Rate (rpm)</b>	> 48600
<b>Max Recommended Rate (rpm)</b>	25000
<b>Max Tracking Acceleration (rpm/sec)</b>	> $16 \times 10^6$
<b>Maximum Feedback Cable Length</b>	50 m (164 ft)

## 4 QUICK START GUIDES

There are two types of Quick Start Guides depending on the Communication Mode of the drive.

If you are using an **S200 Base Unit Drive** (no SynqNet Option Card), follow the S200 Base Unit Drive Quick Start Guide section 4.1.

If you are using an **S200 SynqNet Drive**, follow the S200 SynqNet Drive Quick Start Guide section 4.2.

### 4.1 **S200 BASE UNIT DRIVE—QUICK START**

This Quick Start Guide is designed to help a user quickly setup a base (no option card) S200 Drive. Follow the instructions below if you are using one of the following S200 series S200 drives.

- S20xx0-VTS where 'xx' is any legal number combination

See Drive Model Numbers and Descriptions for a complete list of S200 drives.

The setup consists of the following steps:

1. S200 Tools Software Installation
2. Hardware Setup
3. S200 Tools Communication Wizard
4. Motor Feedback Configuration
5. Save Options

#### 4.1.1 S200 Tools Software Installation

Follow the installation instructions from the CD-ROM or zip file.

S200 Tools supports the following Operating Systems:

- Windows 2003 Server
- Windows XP, All Service Packs – (SP)
- Windows 2000, SP2
- Windows XP embedded
- Windows NT4, SP6

## 4.1.2 Hardware Setup

### 4.1.2.1. DRIVE SETUP

Connect a serial communication cable between the drive and host computer to establish a communication link between the host computer and the S200 Base Unit drive.

1. Plug one end of a serial communications cable to J5 (Serial Port) of the S200 drive and the other end of the cable to the host computer's serial COM port.

**NOTE:** The serial communications cable is not shipped with the drive. It must be ordered separately.

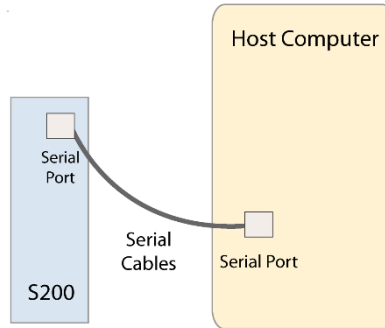

### 4.1.2.2. MOTOR SETUP

If you are using an S200 Base Unit drive, use the J3 connector for motor feedback. Only SFD motor feedback is supported on Base Unit drives. If you want to use SinCos or ComCoder as motor feedback, you must use the AUX FB (J14) connector, which is not available on Base Unit drives. See Drive Model Numbers and Descriptions for a complete list of S200 drives.

## 4.1.3 S200 Tools Communications Wizard

### 4.1.3.1. LAUNCH S200 TOOLS

Launch the S200 Tools program by clicking the desktop icon or from the Windows Start button (Programs > Kollmorgen > S200Tools). The default location for S200Tools.exe, is (C:\Program Files\Kollmorgen\S200Tools).



When the S200 Tools program is launched for the first time, no drives should be listed under the Online or Offline Communications Mode.

### 4.1.3.2. START COMMUNICATION WIZARD

Open the Communication Wizard by selecting it from the toolbar (Utilities > Communication Wizard) or clicking the shortcut icon.

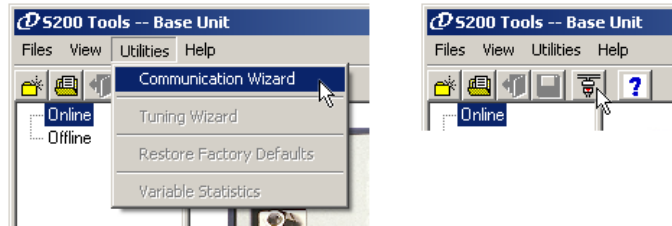

Select **Serial** as the Communications Mode and select the appropriate COM port.

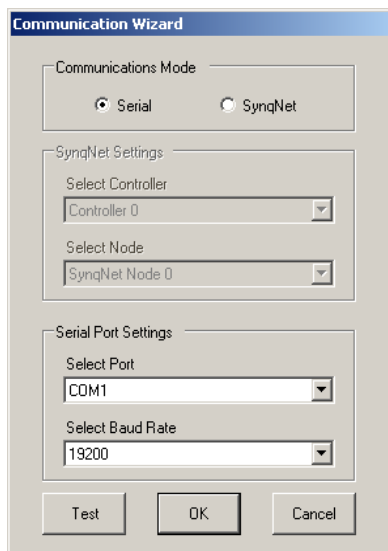



If you do not know which type of drive is connected, click the Test button. The returned message will either say that there is no connection, confirm that you have an S200 connected, or tell you that the connected node is NOT an S200 drive.

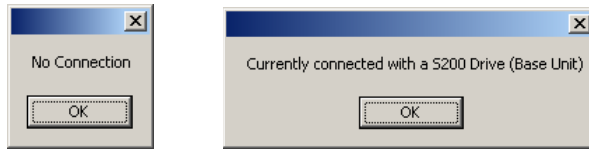

### Troubleshooting

If you receive the "No Connection" message, check the hardware connections. After you have confirmed your setup, click the **OK** button.

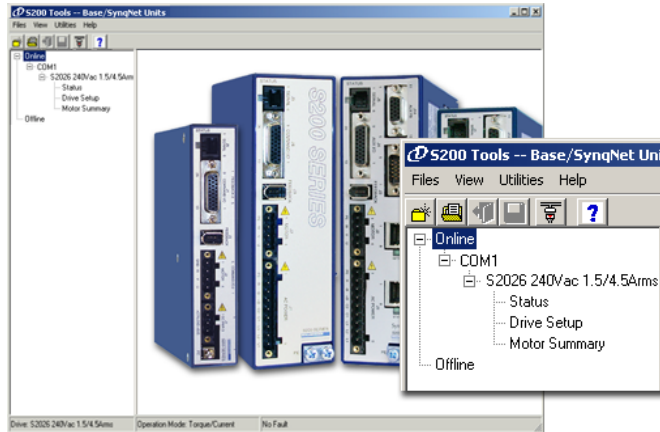

The installed S200 drive(s) will now be listed as "Online" and will list its configuration and status options.

## 4.1.4 Motor Feedback Configuration

The S200 Base Unit drives only support SFD motor feedback. If you are using SFD motor feedback, no further configuration is needed. If you want to use SinCos or ComCoder as motor feedback, you must use the AUX FB (J14) connector, which is not available on Base Unit drives.

## 4.1.5 Save Options

There are three types of Save options. It is important to know how to use each type to ensure that configurations are not lost.

- **Download NV** – This button will save the parameter settings displayed in S200 Tools to the selected drive. These parameters are saved to the drive's permanent memory and are recalled during a power-up cycle.
- **Download Drive** – This button will save the parameter settings displayed in S200 Tools to the selected drive/node. However, unlike Download NV, these parameters are only saved to the drive's temporary RAM and will not be recalled at a power-up cycle. It is recommended that you use the Download Drive button when testing settings. Once you are satisfied with the settings, click the Download NV button to permanently save the settings to the drive.
- **Save/Save As** – You can also save the settings of a drive as a configuration file (\*.S2C). Remember, saving a configuration file does NOT save the settings to the drive. Configuration files can be helpful for saving multiple drive setups. You can easily download a setting to a drive by opening the configuration file in the Offline mode and clicking the Download NV/Drive buttons once the proper drive is selected in the Online mode. It is recommended that you save a configuration file for each setup.

## 4.2 **S200 SYNQNET DRIVE—QUICK START**

This Quick Start Guide is designed to help a user quickly setup a SynqNet option card equipped S200 Drive. Follow the instructions below if you are using one of the following S200 Series Drives:

- S20xx0-SRS where 'xx' is any legal number combination
- S20xx0-SDS where 'xx' is any legal number combination

See Drive Model Numbers and Descriptions for a complete list of S200 drives.

The setup consists of the following steps:

1. MDK and SynqNet Controller Installation
2. S200 Tools Software Installation
3. Hardware Setup
4. S200 Tools Communication Wizard
5. SynqNet Configuration
6. Motor Feedback Configuration
7. Save Options

### 4.2.1 MDK and SynqNet Controller Installation

Before you can use an S200-SynqNet Drive, you must first install the Motion Developer's Kit Software package and SynqNet controller from Motion Engineering Inc. For more information about installation, please see MEI's Technical Support website.

### 4.2.2 S200 Tools Software Installation

Follow the installation instructions from the CD-ROM or zip file. See S200 Tools Software Installation Guide.

S200 Tools supports the following Operating Systems:

- Windows 2003 Server
- Windows XP, All Service Packs - (SP)
- Windows 2000, SP2
- Windows XP embedded
- Windows NT4, SP6

## 4.2.3 Hardware Setup

### 4.2.3.1. DRIVE SETUP

**NOTE: The drive serial port (J5) is disabled on SynqNet drives.**

If you are using an S200 SynqNet Drive, you need to establish SynqNet communication link between the S200 SynqNet Drive and the SynqNet motion controller.

1. Plug one end of an Ethernet communications cable to J11 (SynqNet IN) of the S200 drive and the other end to the SynqNet controller's OUT port.
2. **One Drive/Node**  
Use another Ethernet communications cable to connect J12 (SynqNet OUT) of the S200 drive to the XMP-SynqNet controller's SynqNet IN port.

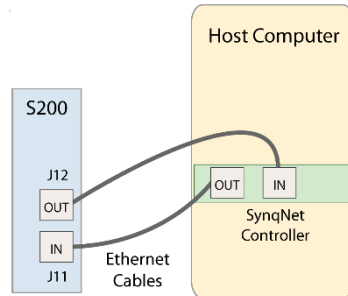

#### Multiple Drives/Nodes

Connect an Ethernet communications cable from the XMP-SynqNet controller's OUT port to the SynqNet IN port (J11) of the first drive/node. Connect an Ethernet cable from the node's SynqNet OUT port (J12) to the SynqNet IN port (J11) of the next node. Connect another cable from the SynqNet OUT port (J12) of the last node in the topology to the SynqNet IN port of the XMP-SynqNet controller.

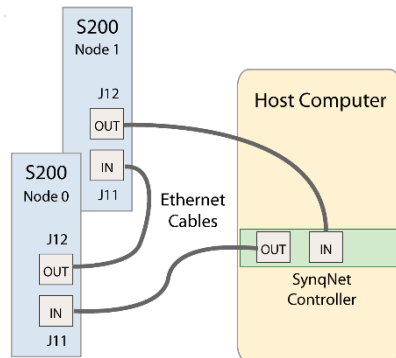

**NOTE:** Although you can connect other SynqNet supported nodes/drives on the SynqNet network, you will only be able to configure the S200 Series Drives with the S200 Tools software. S200 Tools will only communicate with S200 Series Drives.

### 4.2.3.2. MOTOR SETUP

Depending on the type of motor feedback that is used, you will need to use the appropriate feedback connector.

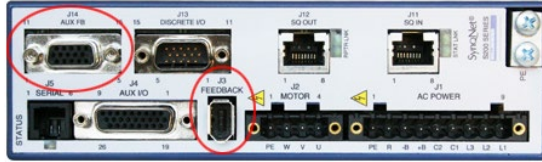

Motor Feedback	J3 Feedback	J14 AUX FB
SFD	X	-
SinCos (with Endat 2.1/2.2)	-	X
SinCos (with Halls)	-	X
ComCoder (Incremental + Halls)	-	X

## 4.2.4 S200 Tools Communication Wizard

### 4.2.4.1. LAUNCH S200 TOOLS

Launch the S200 Tools program by clicking the desktop icon or from the Windows Start button (Programs > Kollmorgen > S200Tools). The default location for S200Tools.exe, is (C:\Program Files\Kollmorgen\S200Tools).

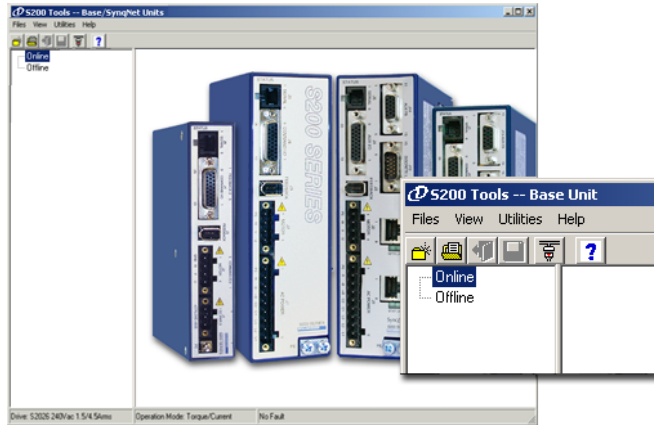

When the S200 Tools program is launched for the first time, no drives should be listed under the Online or Offline Communications Mode.

#### 4.2.4.2. START COMMUNICATION WIZARD

Open the Communication Wizard by selecting it from the toolbar (Utilities > Communication Wizard) or clicking the shortcut icon.

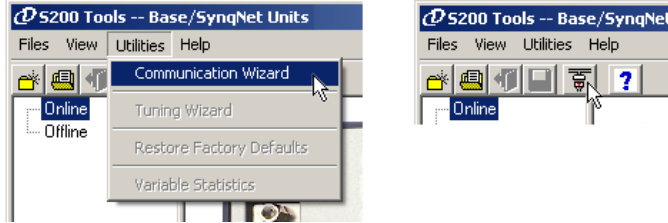

Select **SynqNet** as the Communications Mode.

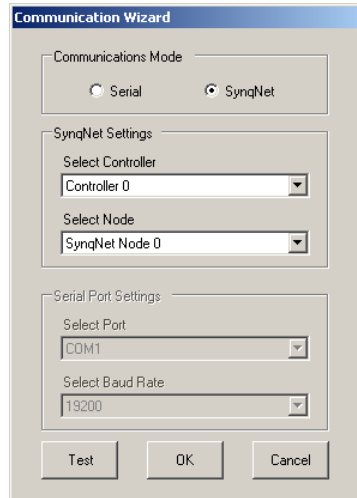

If you do not know which type of drive is connected, click the **Test** button. The returned message will either say that there is no connection, confirm that you have an S200 connected, or tell you that the connected node is NOT an S200 drive.

After you have confirmed your setup, click the **OK** button.

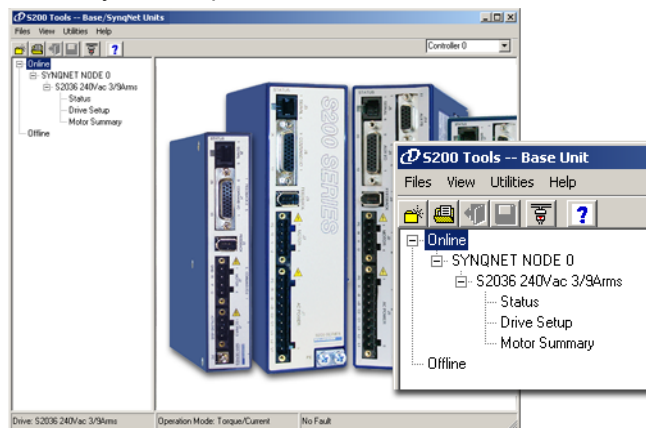

The installed S200 drive(s) will now be listed as "Online" and will list its configuration and status options. If there are additional S200 nodes on the network, they are automatically discovered. When using a network with multiple SynqNet nodes, use the SynqNet controller/node pulldown bars to select a particular node on the network to display in the Online mode.

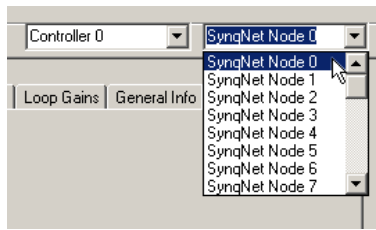

**NOTE for SynqNet:** Although the S200 Tools software maintains communication with all properly connected S200 drives on the SynqNet network, only one SynqNet node will be displayed at a time under the Online display.



## 4.2.5 SynqNet Configuration

The next step is to set the proper drive and motor feedback configurations.

Under the **SynqNet Options tab**, select the source for motor feedback (Feedback Source).

Select **Base Unit Feedback** if the motor feedback is connected to **J3** on the S200 Drive.

Select **Option Card Feedback** if the motor feedback is connected to **J14** on the S200 Drive.

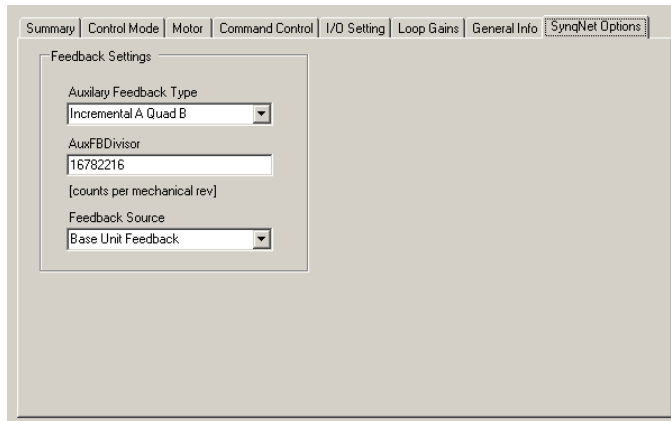

The screenshot shows a software interface with a tabbed menu at the top. The active tab is 'SynqNet Options'. Below the tabs is a 'Feedback Settings' panel. This panel contains three fields: 'Auxiliary Feedback Type' is a dropdown menu set to 'Incremental A Quad B'; 'AuxFBDivisor' is a text input field containing '16782216' with a note below it that says '[counts per mechanical rev]'; and 'Feedback Source' is a dropdown menu set to 'Base Unit Feedback'.

## 4.2.6 Motor Feedback Configuration

The next step is to set the proper motor feedback configurations.

### 4.2.6.1. SFD

If you are using SFD motor feedback, no further configuration is needed.

### 4.2.6.2. SINCOS OR COMCODER

If you are using SinCos or ComCoder as motor feedback, use the equations below to determine the appropriate parameters for setup.

#### **Kip**

$$Kip = 2 * PI() * 2000 * (\text{motor line to line inductance})$$

Ex: l-l inductance = 0.018 H

$$Kip = 2 * PI() * 2000 * (0.018)$$

$$Kip = 226 \text{ V/A}$$

#### **I2TF0**

$$I2TF0 = 5 / (2 * PI() * (\text{motor time constant in minutes}) * 60)$$

Ex: Mtc = 20 minutes

$$I2TF0 = 5 / (2 * PI() * 20 * 60)$$

$$I2TF0 = 0.000663 \text{ Hz}$$

#### **I2TTrip**

$$I2TTrip = (\text{motor continuous current}) * 1.25$$

Ex: Ics = 4 Arms

$$I2TTrip = 4 * 1.25$$

$$I2TTrip = 5 \text{ Arms}$$

#### **ILmtPlus**

$$ILmtPlus = (\text{motor peak current}) / (\text{drive peak current}) * 100$$

Ex: Motor Ip = 4.5 Arms, Drive Ip = 9 Arms

$$\text{Motor Ip} = (4.5/9) * 100$$

$$\text{Motor Ip} = 50\%$$

#### **ILmtMinus**

Typically ILmtMinus is set to the same value as ILmtMPlus. Although there can be asymmetrical current limits in the drive.

#### **Dpoles**

Dpoles = motor poles

## 4.2.7 Save Options

There are three types of Save options. It is important to know how to use each type to ensure that configurations are not lost.

- **Download NV** - This button will save the parameter settings displayed in S200 Tools to the selected drive. These parameters are saved to the drive's permanent memory and are recalled during a power-up cycle.
- **Download Drive** - This button will save the parameter settings displayed in S200 Tools to the selected drive/node. However, unlike Download NV, these parameters are only saved to the drive's temporary RAM and will not be recalled at a power-up cycle. It is recommended that you use the Download Drive button when testing settings. Once you are satisfied with the settings, click the Download NV button to permanently save the settings to the drive.
- **Save/Save As** - You can also save the settings of a drive as a configuration file (\*.S2C). Remember, saving a configuration file does NOT save the settings to the drive. Configuration files can be helpful for saving multiple drive setups. You can easily download a setting to a drive by opening the configuration file in the Offline mode and clicking the Download NV/Drive buttons once the proper drive is selected in the Online mode. It is recommended that you save a configuration file for each setup.

## 5 MOUNTING THE DRIVE

The S200 drives are designed for operation in a cabinet using the following installation instructions:

- Mount the drives vertically inside a cabinet on a flat, solid, electrically conductive mounting surface that is connected to PE (Protective Earth Ground) and capable of supporting the weight of the unit.
- Provide a good connection to PE. Remove the paint on the mounting surface over an area extending at least 12 mm (0.5 in) from the mounting bolts to achieve good electrical connection over a large area between the drive and grounded mounting surface.
- Ensure that the environment within the cabinet meets the requirements listed in the Specifications.

### 5.1 MOUNTING DIMENSIONS

	AC INPUT DRIVES				DC INPUT DRIVES	
	AC1 AC2	AC3	AC4	AC5	DC Base Drive	w/ Option
	S20260 S20360	S20660	S21260	S22460	S20330- VTS S20630- VTS	S20330- x S20630- x
<b>Drive Dimensions</b>						
Drive Height (A)	175.0 mm 6.90 in		177 mm 6.97 in	213 mm 8.39 in	152.4 mm 6.00 in	
Drive Width (B)	54.8 mm 2.16 in	64.0 mm 2.52 in	76 mm 3.00 in	96.4 mm 3.80 in	28.7 mm 1.13 in	48.3 mm 1.90 in
Drive Depth <sup>1</sup> (C)	131.6 mm 5.18 in		152 mm 5.98 in	192 mm 7.57 in	100.8 mm 3.97 in	
<b>Clearance Requirements</b>						
Top and Bottom (D)	12.7 mm 0.50 in	12.7 mm 0.50 in	12.7 mm 0.50 in	19 mm 0.75 in	12.7 mm 0.50 in	12.7 mm 0.50 in
Side to Side (E)	12.7 mm 0.50 in	12.7 mm 0.50 in	12.7 mm 0.50 in	19 mm 0.75 in	12.7 mm 0.50 in	12.7 mm 0.50 in
<b>Mounting Dimensions</b>						
Horizontal Mounting Offset (F)	25.6 mm 1.01 in	25.6 mm 1.01 in	31.7 mm 1.25 in	57.5 mm & 6.5 mm	24.6 mm 0.97 in	24.6 mm 0.97 in
Vertical Mounting Offset (G)	4.3 mm 0.17 in	4.3 mm 0.17 in	2.1 mm 0.08 in	5.0 mm 0.20 in	4.1 mm 0.16 in	4.1 mm 0.16 in
Vertical Mounting Height (H)	166.4 mm 6.55 in	166.4 mm 6.55 in	169.5 mm 6.67 in	202.5 mm 7.97 in	144.3 mm 5.68 in	144.3 mm 5.68 in
Drive to Drive Mounting (J)	67.5 mm 2.66 in	76.7 mm 3.02 in	88.7 mm 3.39 in	115.4 mm 4.54 in	41.40 mm 1.63 in	60.96 mm 2.40 in
<b>Mounting Hardware</b>	M4 or #8	M4 or #8	M4 or #8	M4 or #8	M4 or #8	M4 or #8
<b>Drive Weight</b> (no option card)	0.77 kg 1.69 lb	0.85 kg 1.86 lb	1.33 kg 2.93 lb	2.56 kg 5.64 lb	0.40 kg 0.88 lb	0.5 kg 1.10 lb

<sup>1</sup> Depth measurement is for drive only. Add approximately 50.8 mm (2 in) to depth given in the table to accommodate mating connectors and wire bend radius.

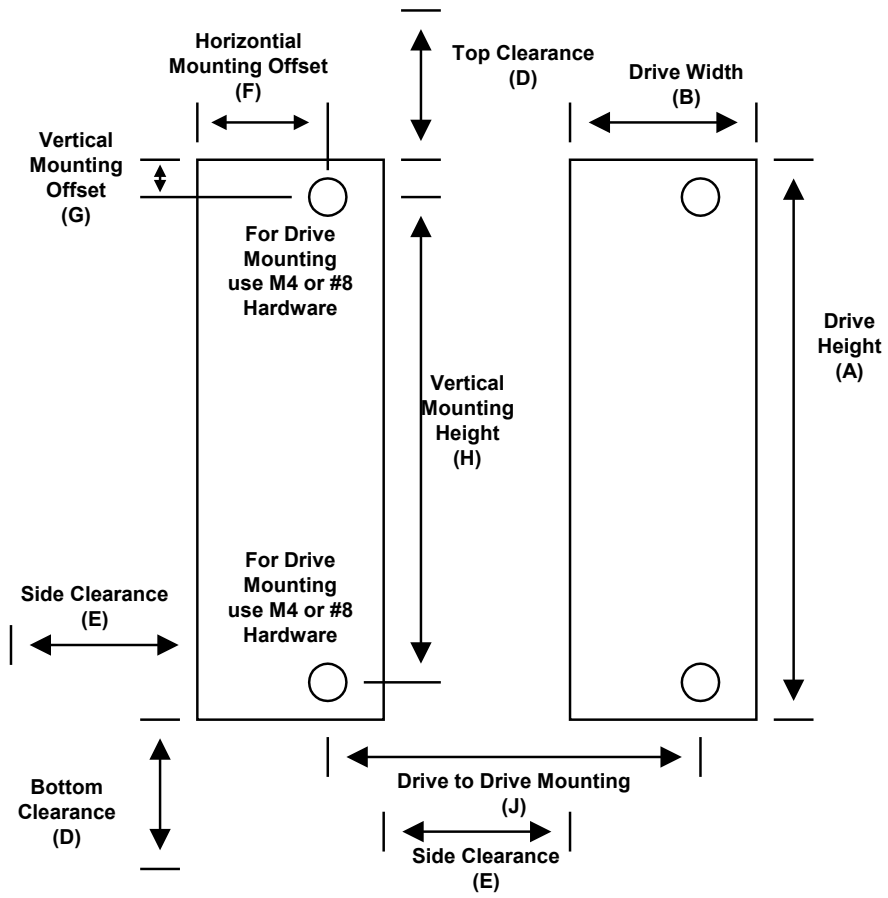

Mounting Dimensions - Front View

See the preceding table for mounting dimensions.

## 5.2 MECHANICAL OUTLINE DRAWINGS

### 5.2.1 Base AC Drive (S20260-, S20360-, S20660-VTS)

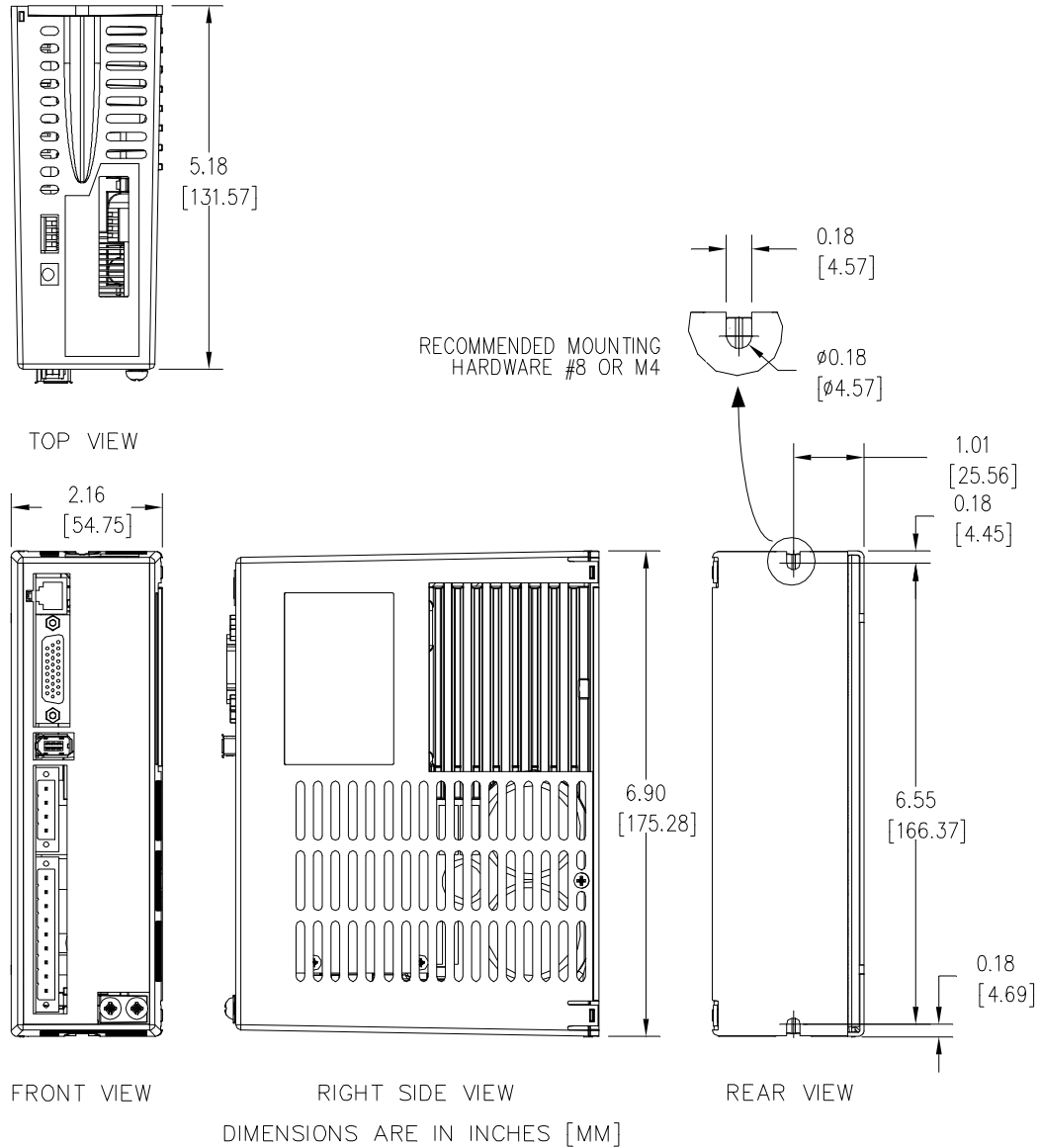

**Note:** All S20660-VTS dimensions are exactly as shown above except for the product width. The 2.16 in [54.75 mm] width above changes to 2.52 in [64.0 mm] for the S20660-VTS.

Enclosure and mounting dimensions for Option card equipped units are the same.

## 5.2.2 Base AC Drive (S21260-VTS)

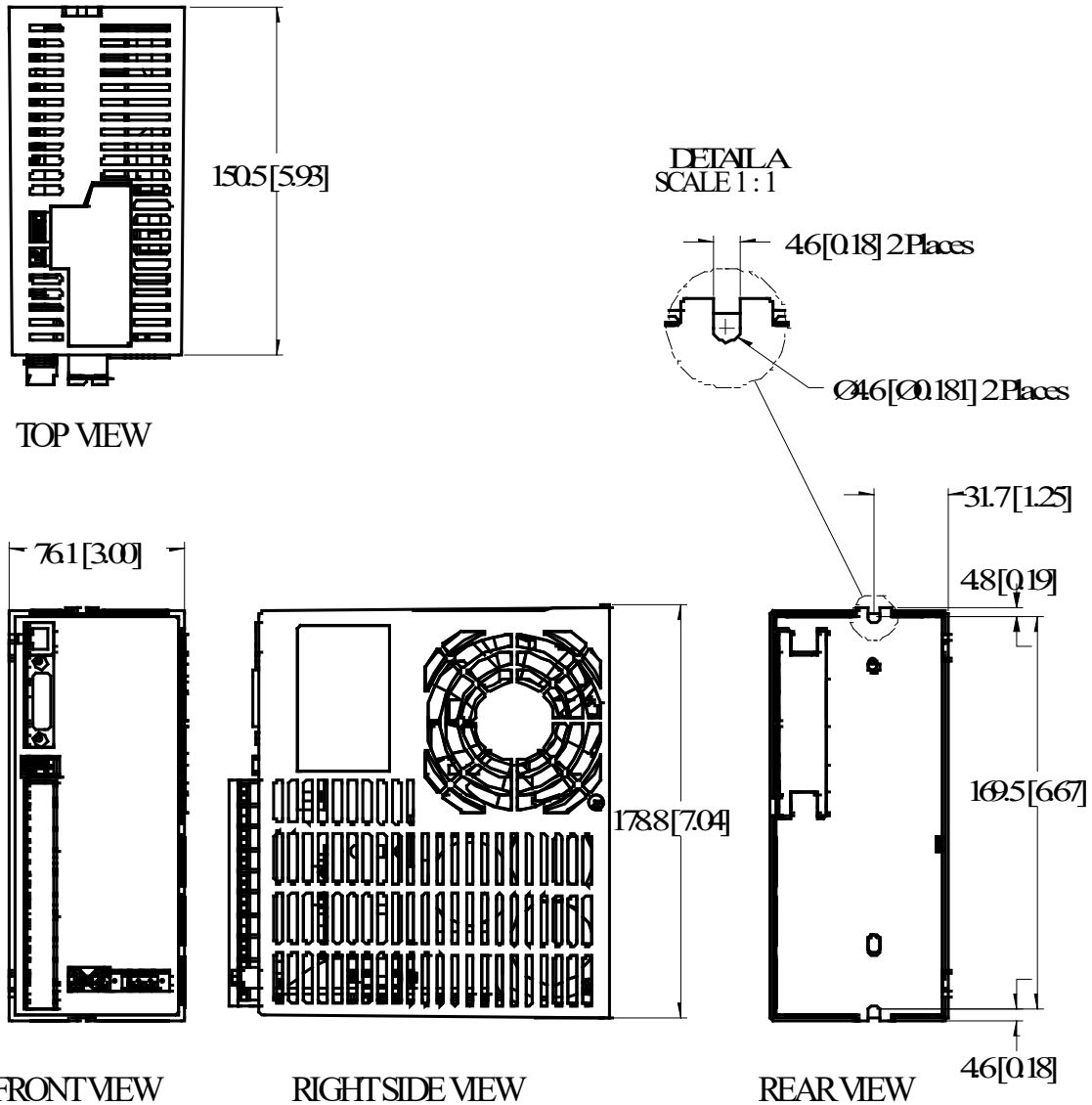

Dimensions are mm [inches]

**Note:** Enclosure and mounting dimensions for Option card equipped units are the same.

### 5.2.3 Base AC Drive (S22460-VTS)

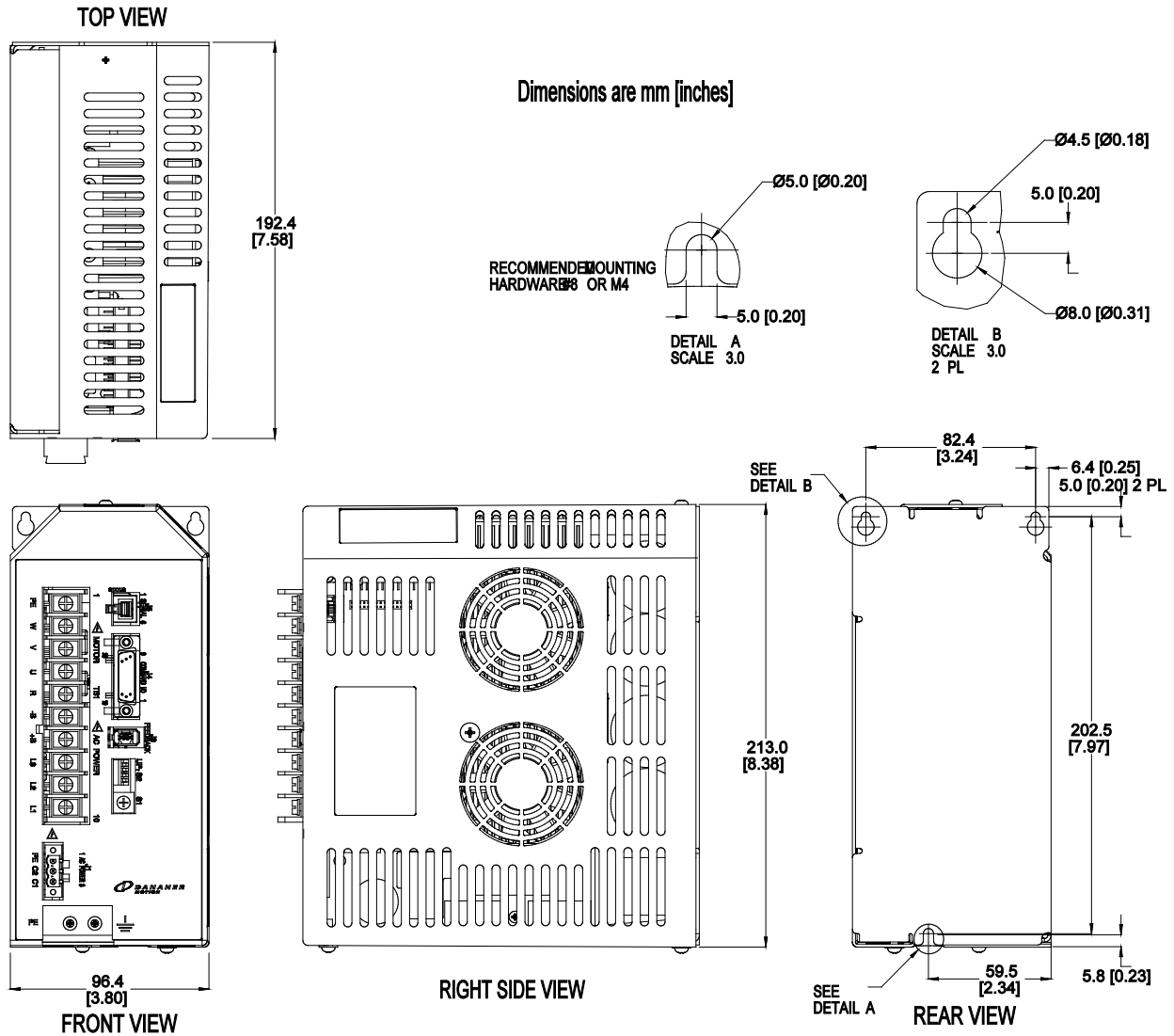

**Note:** Enclosure and mounting dimensions for Option card equipped units are the same.



## 5.2.4 Base DC Drive (S20330-, S20630-VTS)

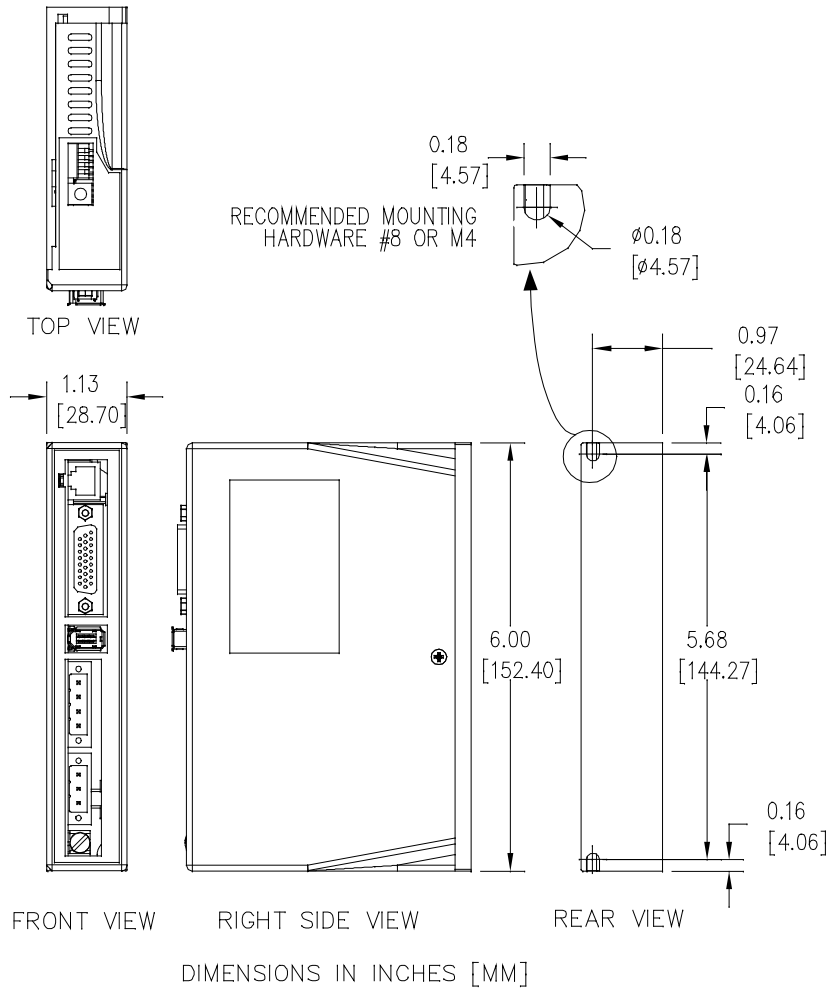

**Note:** Enclosure and mounting dimensions for Option card equipped units are **NOT** the same. See Section 5.2.6 for details.

## 5.2.5 SynqNet AC Drive (S20260-, S20360-, S20660-SRS)

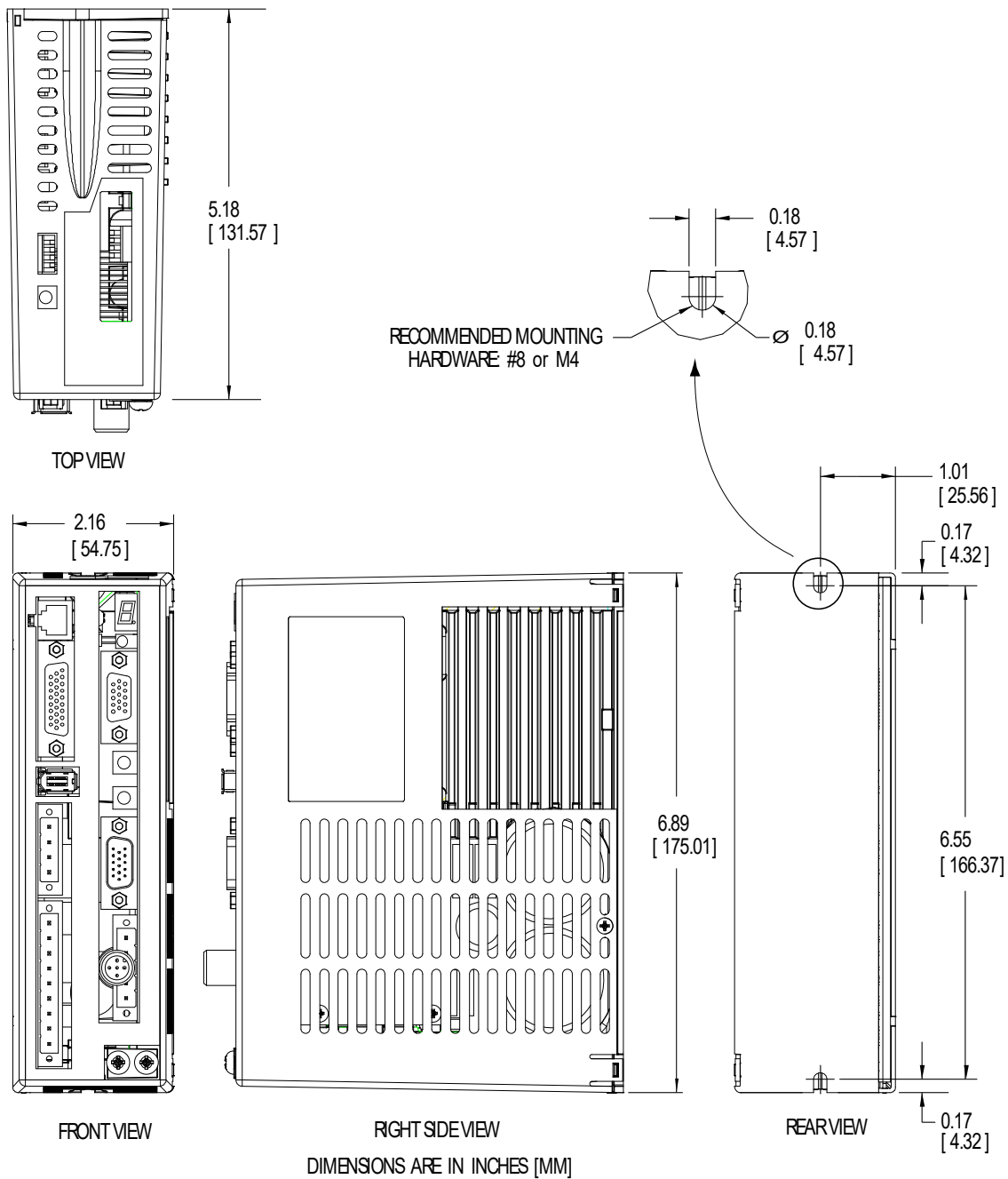

**Note:** All S20660-SRS, S20660-SDS dimensions are exactly as shown above except for the product width. The 2.16 in [54.75 mm] width above changes to 2.52 in [64.0 mm] for the S20660-SRS, S20660-SDS.

## 5.2.6 SynqNet DC Drive (S20330-, S20630-SRS)

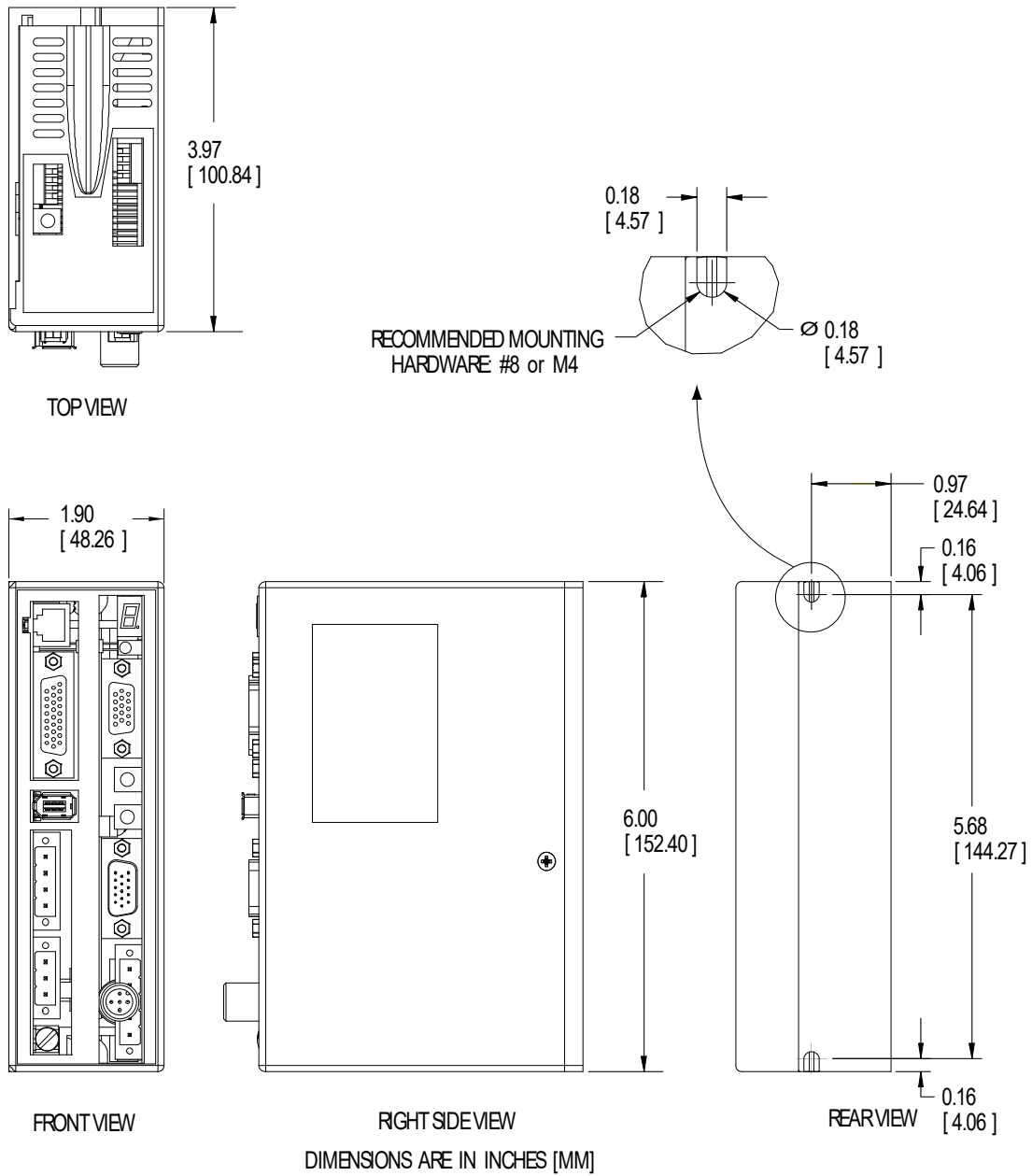

# 6 WIRING THE DRIVE



**READ these instructions before connecting power. Damage can result from MISWIRING at the power terminals.**

**DANGEROUS** voltages are present on power input and motor output terminals.

## 6.1 AC INPUT DRIVE WIRING

### 6.1.1 AC Drive (S20260-, S20360-, S20660-VTS)

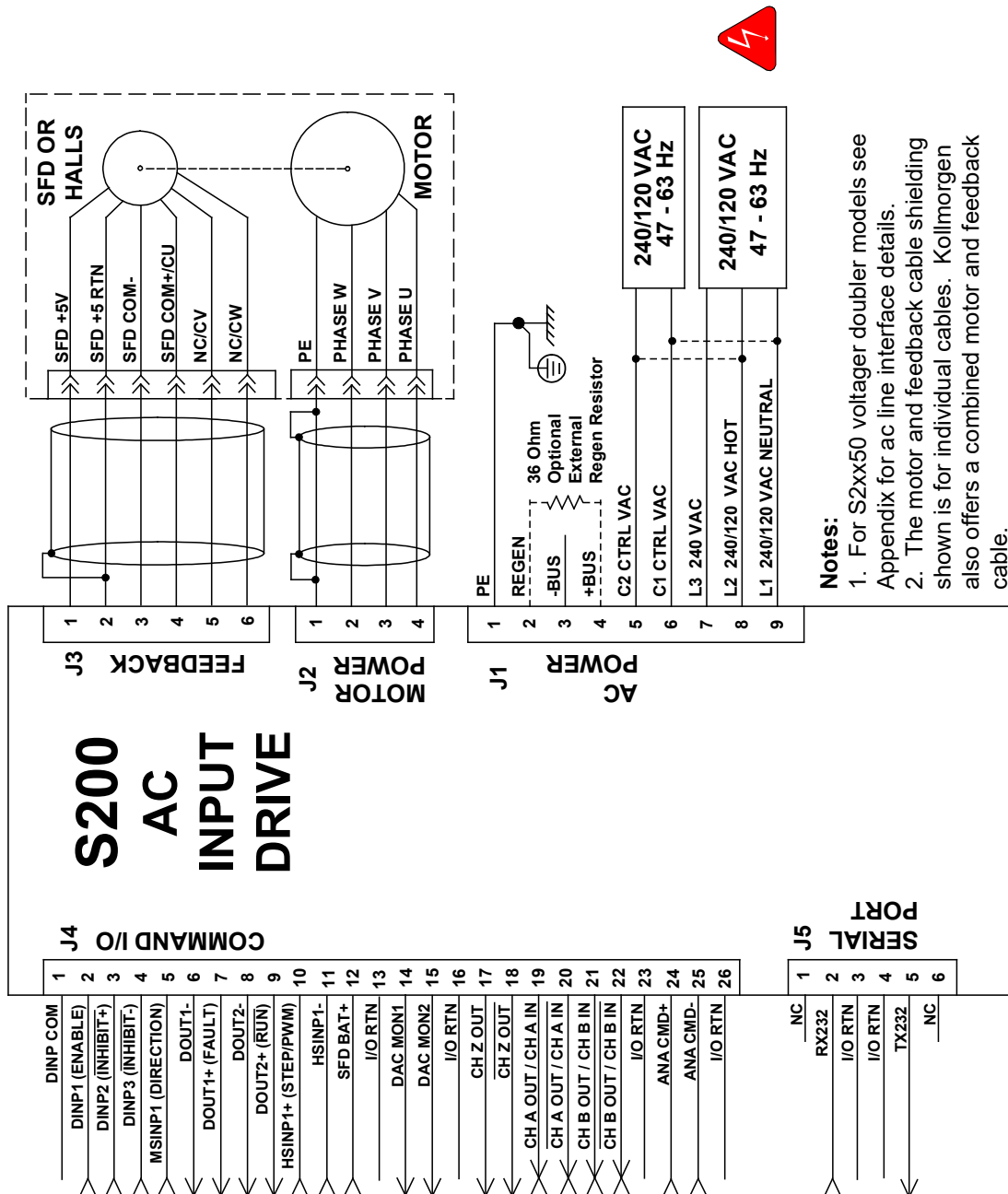

# 6.1.2 AC Drive (S21260-, S22460-VTS)

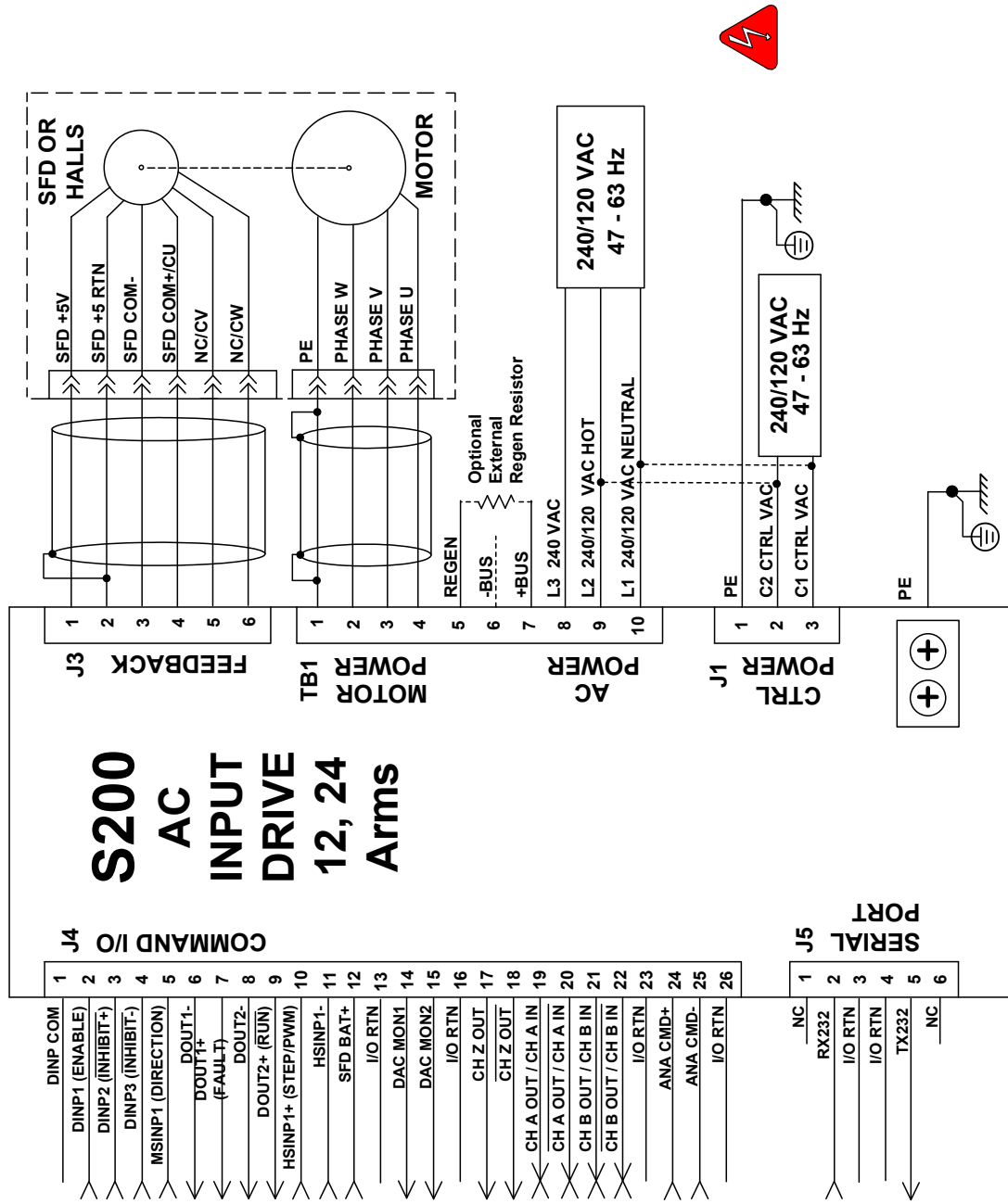

## 6.2 J1 – AC INPUT DRIVE POWER

The S200 AC input drives are capable of direct line operation. All units are fully isolated and do not require external isolation transformers. The inrush current on the connection to the line is internally limited to a safe level for the drive. There are no voltage selection or ranging switches required to operate within the specified voltage input ranges.

The S200 series drives are functionally compatible with all standard forms of three phase AC lines:

- Grounded neutral WYE
- Open-Delta Grounded Leg
- TEE



**NOTE**

***The customer is responsible for supplying the appropriate fuses or circuit breakers in the J1 AC motor power lines to comply with local electrical codes.***

The control input power required is between 5 and 10 watts. The AC input motor power depends on output power and losses in the power stage.



**CAUTION**

***Appendix G – Regulatory Information of this manual contains additional information needed to ensure regulatory compliance.***

On AC input drives with peak current < 18 Arms, J1 is a 9 pin pluggable connector (shown below). On larger AC input drives connections are to fixed terminal block TB1 that needs no mating connector. See wiring diagrams for full connection details.

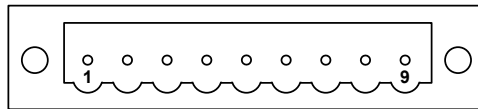

**J1 Connector view from front of drive.**

Pin	Description
J1-1	PE (Protective Earth)
J1-2	REGEN
J1-3	-BUS
J1-4	+BUS
J1-5	C2 CTRL VAC
J1-6	C1 CTRL VAC
J1-7	L3 240 VAC
J1-8	L2 240/120 VAC
J1-9	L1 240/120 VAC

### **Mating Connector Information for S20260, S20250, S20360, S20560, S20660**

Screw Terminal Connector

12 – 24 AWG Wire Range, Phoenix MSTB2,5/9-STF-5,08-BK

OR

Spring Cage Clamp Connector

12 – 24 AWG Wire Range, Phoenix FKC 2,5/9-SFT-5,08-BK

OR

Crimp Connector

Crimp Shell

14-20 AWG Wire Range, Phoenix MSTBC 2,5/9-STZF-5,08-BK

Crimp Contact

14-16 AWG Wire Range, Phoenix MSTBC-MT 1,5-2,5

Crimp Contact

18-20 AWG Wire Range, Phoenix MSTBC-MT 0,5-1,0

**Refer to <http://www.phoenixcon.com>.**



**To avoid damage to the connector and drive, NEVER plug or unplug J1 with power applied.**

**J1-1 or Chassis  
Screw PE  
Protective Earth**

This chassis ground point **must be connected to Protective Earth ground**. The connection at the Protective Earth ground end **must be hard wired** (do not use a pluggable connection). A ground fault detector (RCD) cannot be depended on for safety.

**J1-2 or TB1-5  
REGEN**

Connection for an optional regeneration power resistor to absorb regenerated energy from the motor. Models S20260 and S20360 typically use 36  $\Omega$ . S20660, S21260 typically use 12.5  $\Omega$ , and S22460 typically uses 8  $\Omega$ . Other values within the min to max resistance specification range can be used. Use a Wire wound resistor with 1500 V<sub>RMS</sub> isolation between terminals and case. Many applications do not require a regen resistor. If over-voltage faults occur during motor deceleration, then the more kinetic energy is being returned to the bus capacitors than they can handle. Connect the proper Ohmage 50 to 1000 watt power resistor from this terminal, to terminal J1-4 (+BUS) in order to eliminate the over-voltage faults. The power rating of the regen resistor depends on the amount of regenerated energy that needs to be dissipated.



**The regen input is not short circuit protected. The regen resistance MUST be within specified ranges to prevent damage to the drive. For example, S20260, S20360 drives must be between 25 to 50  $\Omega$ .**



**NOTE**

**For safety, either mount the external resistor on a grounded panel or wire it to a grounded connection. The terminals of the resistor MUST NOT be grounded.**



**WARNING**

**Wait 5 minutes after power is removed for the bus cap voltage to decay to a safe level before touching the regen resistor or wiring. Monitor the voltage on the bus caps with a voltmeter from +BUS (J1-4) to -BUS (J1-3).**

**J1-3 or TB1-6  
-BUS**

The -BUS terminal is usually left open during normal operation. In special multi-axis applications, drive buses can be wired in parallel to allow returned energy from one motor to power another and limit high regen powers.

**J1-4 or TB1-7  
+BUS**

The +BUS terminal is used with the J1-2, REGEN, terminal to add a regen resistor to the drive to absorb regenerated energy.

**J1-5, J1-6  
or J1-2, J1-3  
C2 CTRL VAC  
C1 CTRL VAC**

These terminals connect 120/240 VAC power to the drive's control voltage power supply.

S21260, S2460 on separate 3 pin pluggable J1.

**These terminals are NOT connected to the bus power L1, L2 (J1-8,9) inside the drive.**

<b>Input Voltage Range (RMS)</b>	85 VAC to 265 VAC single phase 47 to 63 Hz 120 VDC to 375 VDC
<b>Inrush Peak Current</b>	10 A 0-p with 240 VAC Input
<b>Inrush pulse width</b>	1.60 ms
<b>Fusing</b>	Bussmann MDA – ½

**NOTE**

*For maximum ride through capability a 240 VAC input is recommended.*

**J1-7, J1-8, J1-9  
or TB1-8,9,10  
L3 240 VAC  
L2 240/120 VAC  
L1 240/120 VAC**

These terminals connect 120/240 VAC power to the drive's output power stage BUS for motor power.

For single-phase operation, 120/240 use inputs J1-8, L2, and J1-9, L1.

<b>Input Voltage Range (RMS)</b>	S20260, S20360, S20660: 0 to 265 VAC S21260, S22460: 120 to 265 VAC
<b>Phases</b>	1 or 3
<b>Transformer</b> (recommended KVA if transformer is required.)	S20260: 1.5 to 2 kVA S20360: 2.0 to 3 kVA S20660: 3.0 to 5 kVA S21260: 4.5 to 6 kVA S22460: 8.0 to 12 kVA
<b>Maximum AC Line KVA<sup>1</sup></b>	S20260, S20360, S20660: 100 S21260, S22460: 250

<sup>1</sup>*Maximum AC Line is specified to limit the mains surges to the drive.*

<b>Recommended Fusing Line Inputs</b>	<b>S20260</b>	<b>S20360</b>	<b>S20660</b>	<b>S21260</b>	<b>S22460</b>
<b>Type – 250 VAC Time Delay Fuse</b>					
240 VAC 3 Phase (ARMS)	Bussmann FRN-R-5	Bussmann FRN-R-8	Bussmann FRN-R-15	Bussmann JKS-20	Bussmann JKS-30
240 VAC 1 Phase (ARMS)	Bussmann FRN-R -5	Bussmann FRN-R-10	Bussmann FRN-R-20	Bussmann JKS-30	Bussmann JKS-30
120 VAC 1 Phase (ARMS)	Bussmann FRN-R -5	Bussmann FRN-R-10	Bussmann FRN-R-20	NA	NA



### 6.3 DC INPUT DRIVE WIRING

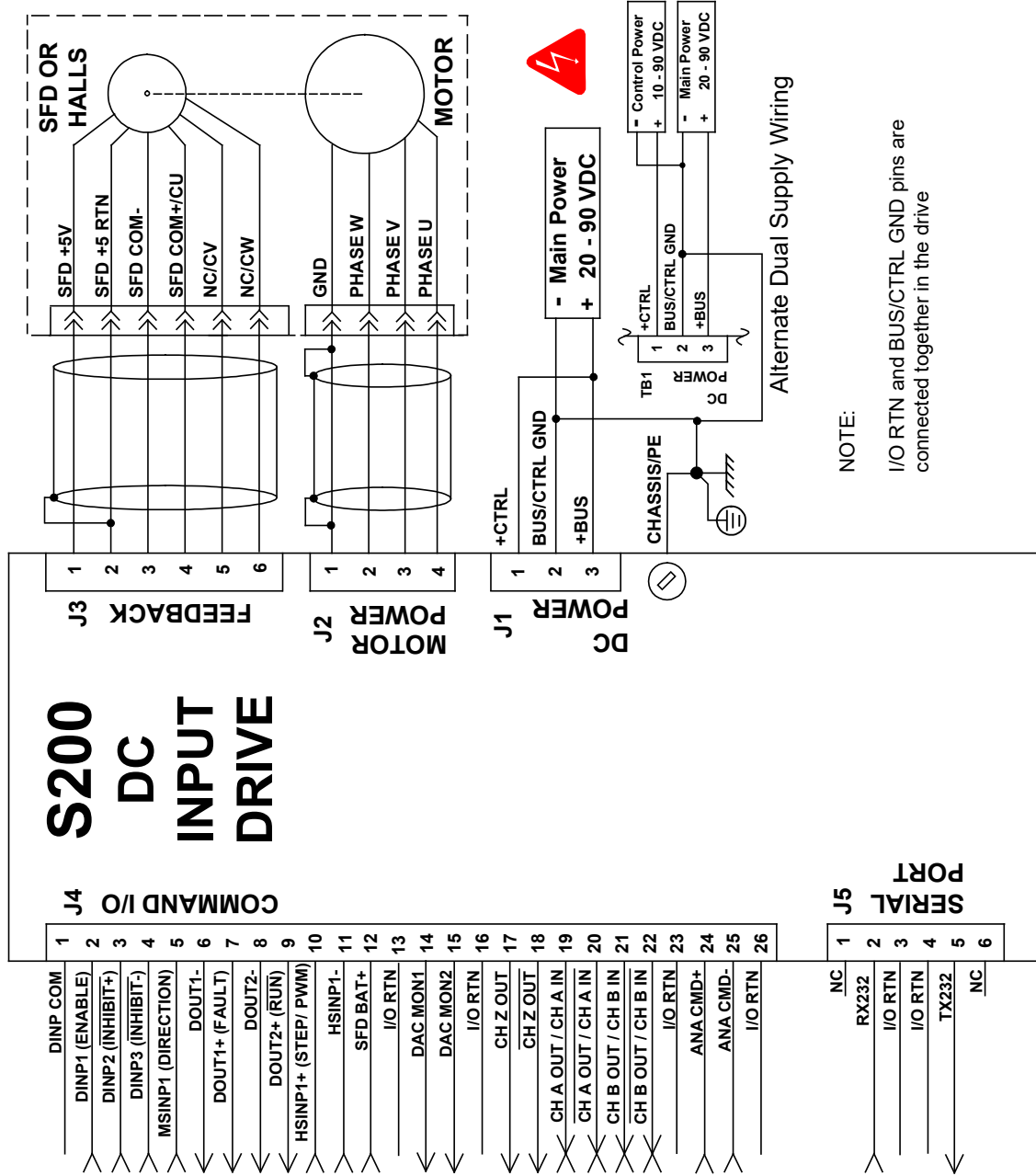

## 6.4 J1 – DC INPUT DRIVE POWER

The S200 DC input drives should be powered from power supplies with reinforced isolation. On DC input drives, J1 is a 3 pin pluggable connector.

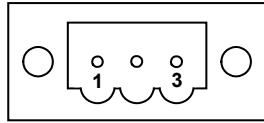

(J1 Connector view from front of drive).

Pin	Description
J1-1	+CTRL
J1-2	BUS/CTRL GND
J1-3	+BUS



**To avoid damage to the connector and drive, NEVER plug or unplug J1 with power applied.**

### Mating Connector Information

Screw Terminal Connector

12 – 24 AWG Wire Range, Phoenix MSTB2,5/3-STF-5,08-BK  
OR

Spring Cage Clamp Connector

12 – 24 AWG Wire Range, Phoenix FKC 2,5/3-SFT-5,08-BK  
OR

Crimp Connector

Crimp Shell

14-20 AWG Wire Range, Phoenix MSTBC 2,5/3-STZF-5,08-BK

Crimp Contact

14-16 AWG Wire Range, Phoenix MSTBC-MT 1,5-2,5

Crimp Contact

18-20 AWG Wire Range, Phoenix MSTBC-MT 0,5-1,0

**Refer to [www.phoenixcon.com](http://www.phoenixcon.com).**

#### J1-1

#### +CTRL

**Control power input.** The DC drive accepts +10 to +90 VDC on this input referenced to J1-2. An isolated regulated or isolated unregulated power supply can be used. This input can be connected to +Bus input (J1-3) and powered by the same supply as +Bus. The control power supply should be rated for 20 watts. While the power drain typically is 2 W to 8 W, a 20 W supply ensures reliable starting of the drive.

#### J1-2

#### BUS/CTRL GND

**Power return for the control and BUS power supplies.** The BUS/CTRL GND is connected to I/O RTN internally in the drive.

#### J1-3

#### +BUS

**Main power input to the drive.** The DC drive accepts +20 to +90 VDC on this input referenced to J1-2. An isolated regulated or isolated unregulated power supply can be used. The +Bus power drain with +Bus voltage at 75 VDC is in the range shown below. It varies according to the application and motor.

	S20330 (3 Amp)	S20630 (6 AMP)
<b>+Bus Continuous Power</b>	250 watt	500 watt
<b>+Bus Peak Power</b>	750 watt	1,500 watt

**NOTE**

**Refer to the DC Power Supply Requirements section for detailed requirements selecting a compatible power supply.**

**PE Screw Connection**      **Protective Earth connection point.** This chassis ground point **must be connected to Protective Earth ground.** The connection at the Protective Earth ground end **must be hard wired** (do not use a pluggable connection).  
**A ground fault detector (RCD) cannot be depended on for safety.**

## 6.4.1 DC Power Supply Requirements

<b>Bus Voltage (J1-3 to J1-2)</b>	+ 20 VDC to + 90 VDC
-----------------------------------	----------------------

<b>BUS Supply Current</b>	<b>48 VDC BUS</b>	<b>75 VDC BUS</b>
S20330 Continuous Peak (3 sec)	3.3 ADC at 160 W 10 ADC at 480 W	3.3 ADC at 250 W 10 ADC at 750 W
S20630 Continuous Peak (3 sec)	6.7 ADC at 320 W 20 ADC at 960 W	6.7 ADC at 500 W 20 ADC at 3,000 W

<b>BUS Supply Current</b>	<b>48 VDC BUS</b>	<b>75 VDC BUS</b>
S20330 Continuous Peak (3 sec)	3.3 ADC at 160 W 10 ADC at 480 W	3.3 ADC at 250 W 10 ADC at 750 W
S20630 Continuous Peak (3 sec)	6.7 ADC at 320 W 20 ADC at 960 W	6.7 ADC at 500 W 20 ADC at 3,000 W

<b>Bus Supply Characteristics</b>	<p>The BUS Supply should have the following characteristics:</p> <ul style="list-style-type: none"> <li>● Must provide safety isolation from the power line.</li> <li>● Can be regulated or unregulated.</li> <li>● Bus Supply Return is connected to the Control Supply Return and I/O RTN in the drive.</li> </ul> <p>Typical BUS Supply:</p> <ul style="list-style-type: none"> <li>● Unregulated, Isolating, step-down transformer with secondary rectified into capacitive filter.</li> <li>● BUS Supply Return is connected to earth ground.</li> </ul>
<b>Wiring from BUS Supply to Drive</b>	<p>10 ft maximum  16 AWG (minimum)  Twisted pair  Daisy chaining of multiple drive OK.  No contactor or switching in the BUS wiring.</p>
<b>Control Voltage (J1-1 to J1-2)</b>	+ 10 VDC to +90 VDC
<b>Control Supply Type</b>	<p>Isolating  Unregulated or Regulated  Common GND with bus supply and I/O RTN.  20 watt supply or 1 amp short circuit.</p>
<b>Control Supply Wiring</b>	<p>Wire control (J1-1) to bus (J1-3)  <b>or</b>  Wire control (J1-1) to separate supply to preserve status and fault information. (+ 10 VDC to + 30 VDC supply can be shared by Control and I/O)</p>
<b>Control Supply Current</b>	<p>20 to 110 mA at 75 VDC  60 to 330 mA at 24 VDC  125 to 660 mA at 12 VDC</p>

## 6.4.2 Bus Voltage

Bus voltage outside the operating range (20 to 90 V) causes an undervoltage or overvoltage fault. Undervoltage and overvoltage faults are self-cleared when the fault conditions are cleared.



***Do Not allow the Bus Voltage to exceed + 90 VDC as it can damage the drive.***

Target design center voltage for unregulated supply is +70 to +75 VDC. This provides 15 to 20 VDC margin for line tolerance, transformer regulation, and regen pump up. Design center voltage for a regulated supply can be up to +80 VDC.

## 6.4.3 Control Voltage

The control voltage range for normal operation is +10 VDC to +90 VDC. The control voltage can either be wired to the bus voltage so one supply can power the drive, or from a separate supply. Separately powering the control from the bus allows the bus to be powered down for safety while drive status and fault information remain available.

NOTE: Control and I/O can share a single +10 VDC to +30 VDC power supply.



***Do NOT allow the Control Voltage to exceed + 90 VDC as it can damage the drive.***

## 6.4.4 Grounding

Provide safety isolation with the external bus and control supplies from the power line.



***The drive cannot be powered from an electrically Hot supply as it does not contain an isolation barrier.***

The Ctrl and Bus voltages and non-opto coupled I/O grounds (I/O RTN) are commoned inside the drive. The Ctrl and Bus power supplies share a ground pin (Bus/Ctrl Gnd). Join and connect to the negative terminals of the Ctrl and Bus power supplies. The I/O RTNs are normally connected to the signal ground of the system. (Some of the I/O is opto coupled and have separate returns. Be sure to thoroughly review this document for details.)

The power supply negative terminal should be grounded somewhere in the cabinet. The chassis should also be grounded. In normal operation there should be no significant voltage between ground and the Bus/Ctrl Gnd and I/O RTNs.



***The maximum voltage allowed between Bus/Ctrl Gnd and chassis is 100 VDC.***

## 6.4.5 Bus Capacitance

There is a minimum requirement on the output capacitance of the bus power supply for the S200 DC Input Drives. This capacitor is needed to absorb energy during motor deceleration and motor disable. It also helps provide energy during motor acceleration. For multiple S200 drives operated from one supply, the recommendation is to increase the capacitance according to the number of drives. For example, for four 6 A / 18 ARMS DC S200 drives powered from one 75 VDC supply, the recommended minimum bus output capacitance of the supply is  $4 \times 4,000 \mu\text{f} = 16,000 \mu\text{f}$ . Bus capacitor voltage rating should be 100 V. Bus capacitor type is aluminum electrolytic.

## 6.4.6 Bus Switching and Fusing

Do NOT put E-Stop switches or contactors between the drive bus pin (J1-3) and the power supply bus capacitor. There is a risk of damage to the drive if the bus is disconnected from the power supply capacitor when the drive is enabled. The motor does not need to be rotating to regenerate energy. The motor windings store magnetic energy that regenerates back to the supply when the drive is disabled.

E-stop switches can safely be located in series with the primary winding of a step down transformer. If individual axis E-Stop switches are required, connect a local (unswitched) capacitor (1,000  $\mu\text{f}$ , 100 V) across the drive bus terminals (J1-3 to J1-2). If the buses of individual drives are to be fused, select the fuse type and rating for high margin.

S20330 (3 amp)	S20630 (6 amp)
7 A, Slo-Blo (Bussmann MDA-7)	15 A, Slo-Blo (Bussmann MDA-15)

## 6.5 J2 – MOTOR POWER CONNECTOR

On smaller drives with Drive Ipeak 18 Arms or less J2 is a 4 pin pluggable connector. On larger drives the motor power connection is made on fixed terminal block TB1 and needs no mating connector.

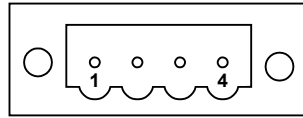

(J2 Connector view from front of drive).

Pin	Description
J2-1	S200 AC Input Drives: PE (Physical Earth) S200 DC Input Drives: BUS/CTRL GND
J2-2	Motor Phase W
J2-3	Motor Phase V
J2-4	Motor Phase U

### Mating Connector Information

Screw Terminal Connector

12 – 24 AWG Wire Range, Phoenix MSTB2,5/4-STF-5,08-BK  
OR

Spring Cage Clamp Connector

12 – 24 AWG Wire Range, Phoenix FKC 2,5/4-SFT-5,08-BK  
OR

Crimp Connector

Crimp Shell

14-20 AWG Wire Range, Phoenix MSTBC 2,  
5/4-STZF-5,08-BK

Crimp Contact

14-16 AWG Wire Range, Phoenix MSTBC-MT 1,5-2,5

Crimp Contact

18-20 AWG Wire Range, Phoenix MSTBC-MT 0,5-1,0

Refer to [www.phoenixcon.com](http://www.phoenixcon.com).

**J2-1 or TB1-1  
PE** On S200 AC Input Drives this point is connected to Chassis Ground.

**Motor Case  
Ground** On S200 DC Input Drives this point is connected to BUS/CTRL GND.

In either case this termination provides a convenient point for the motor ground connection and motor power wire shield.

Local electrical code may require using the Earth Ground Chassis stud for this function.

**J2-2, 3, 4  
or TB1-2,3,4  
Motor Phases** These three terminals provide the 3-phase power output from the drive to the motor.

**Observe motor polarity, connect phase U on the drive to phase U on the motor, etc.**

**For nonstandard motor drive combinations see Appendix D – Process To Set Up Non-Kollmorgen Motors or consult the factory for proper phase orientation.**



NOTE

## 6.6 J3 – FEEDBACK CONNECTOR

J3 is a 6-pin pluggable IEEE 1394 style connector for the feedback device. Although this connector mechanically accepts standard IEEE 1394 cables, it is electrically **not** a 1394 interface. The base drive accepts either SFD (Smart Feedback Device) or Hall inputs.

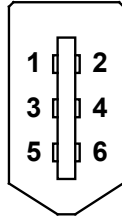

(J3 Connector view from front of drive)

Pin	Description
J3-1	SFD +5 V (200 mA)
J3-2	SFD +5 RTN
J3-3	SFD COM-
J3-4	SFD COM+/CU
J3-5	NC/CV
J3-6	NC/CW
Shell	Shield Connection

### Mating Connector Information

IEEE1394, Firewire type, 2.0 mm plug set

22 AWG Max., Molex 55100-0600

**Refer to [www.molex.com](http://www.molex.com) for assembly instructions.**

<b>J3 –1 SFD +5 V</b>	This terminal provides a 5 VDC output to power the feedback device. For example, motors equipped with SFD, Halls or a commutation encoder. The load current should not exceed 200 mA.
<b>J3-2 SFD +5 RTN</b>	This terminal is the return connection for the 5 VDC supply. An inner feedback cable shield can be connected to this point. Outer shields should connect to the shell which is PE.
<b>J3-3 SFD COM-</b>	SFD serial communications port when using the SFD feedback device. No connection when using Hall feedback.
<b>J3-4 SFD COM+ / CU</b>	SFD serial communications port when using the SFD feedback device. CU (Commutation Phase U) input when using open collector Hall feedback. This input has a 2.21 kW pull-up resistor to 3.3 V.
<b>J3-5 NC / CV</b>	No connection when using the SFD feedback device. CV (Commutation Phase V) input when using open collector Hall feedback. This input has a 2.21 kW pull-up resistor to 3.3 V.
<b>J3-6 NC / CW</b>	No connection when using the SFD feedback device. CW (Commutation Phase W) input when using open collector Hall feedback. This input has a 2.21 kW pull-up resistor to 3.3 V.
<b>Shell</b>	Outer shield connection (wired to PE in the drive).

## 6.7 J4 – COMMAND I/O CONNECTOR

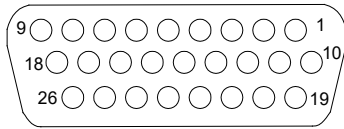

J4 is a 26-Position High Density D subminiature female connector.

(J4 Connector view from front of drive.)

Pin	Description	Pin	Description
J4-1	DINP COM	J4-14	DAC MON1
J4-2	DINP1 (Enable)	J4-15	DAC MON2
J4-3	DINP2 (Inhibit +)	J4-16	I/O RTN
J4-4	DINP3 (Inhibit -)	J4-17	Encoder Output Channel Z
J4-5	MSINP1 (Direction)	J4-18	Encoder Output Channel $\overline{Z}$
J4-6	DOUT1-	J4-19	Channel A Encoder Output/Input
J4-7	DOUT1+ (Fault)	J4-20	Channel $\overline{A}$ Encoder Output /Input
J4-8	DOUT2-	J4-21	Channel B Encoder Output /Input
J4-9	DOUT2+ ( $\overline{RUN}$ )	J4-22	Channel $\overline{B}$ Encoder Output /Input
J4-10	HSINP1+ (Step/PWM)	J4-23	I/O RTN
J4-11	HSINP1-	J4-24	Analog Command Input +
J4-12	SFD BAT+	J4-25	Analog Command Input -
J4-13	I/O RTN	J4-26	I/O RTN

### Mating Connector Information

26-Pin Male High Density D-Sub with Back shell Kit

24 AWG Max., NorComp 180-026-102-001 – D-Sub Connector

NorComp 978-015-010-03-1 – Back shell Kit

Refer to [www.norcomp.net](http://www.norcomp.net).

### 6.7.1 General Purpose Inputs

**General Purpose Inputs DINP1-3**  
J4-2, 3, 4

**MSINP1**  
J4-5

**Common Input Terminal**  
J4-1

The general purpose inputs are a bank of four inputs that share a common terminal (DINP COM) on J4-1. The inputs operate over a wide input voltage range of  $\pm 4.0$  to  $\pm 30$  V. General purpose inputs are compatible with either sourcing or sinking currents to provide maximum flexibility for interfacing to field wiring.



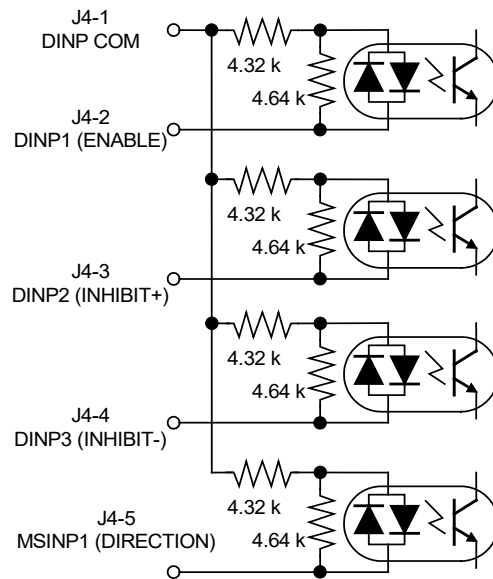

Input current is a function of the input voltage and listed in the following table.

Input Voltage ( $\pm$ )	Input Current ( $\pm$ )
4.0 volts	0.65 mA
5.0 volts	0.95 mA
12 volts	2.5 mA
24 volts	5.3 mA
30 volts	6.7 mA

The response time for DINP1, DINP2, and DINP3 is less than 1 ms. DINP4 has a response time of less than 100  $\mu$ s.



**NOTE**

***For fastest response to an input, configure the drive to respond when the input optoisolator is turned on (current starts flowing in the photo diode). Response time is cut approximately in half.***

### 6.7.1.1. DEFAULT INPUT FUNCTIONS

The list below describes the factory default functions for each of these inputs. A logic input hardware is active when current is flowing through its photo diode. Inactive logic input hardware is open circuited (has no photo diode current). The active control logic polarity of each input can be set by the corresponding **DInpXPol** NV Parameter. In other words, depending on the state of **DInpXPol**, a given hardware input driven active, will activate or not activate a drive control function.

#### **DINP1 (ENABLE)**

**Input 1:** The ENABLE control function mapped to this input enables/disables the drive and resets the latched drive faults. With default logic polarity (**DInp1Pol** = Normal), the drive can enable when input 1 is activated (current flowing in the photo diode) and will be disabled when open circuited. This input will disable a drive independent of any other parameters. Successful enabling requires no drive faults and **SWEnable**, SynqNet drive enable active as appropriate.

Setting this input to the inactive state clears any latched drive faults.

#### **DINP2 (INHIBIT+)**

**Input 2:** The INHIBIT+ control function mapped to this input prevents further motion in the clockwise shaft motion direction when activated by current flowing in the photo diode. This input has no effect on motion in the counter-clockwise direction. This function can be turned on or off by setting **EnhibitCW**. **DInp2Pol** sets the control logic active polarity for this hardware input.

This input is useful for a clockwise over travel limit switch. Broken wire “failsafe” over travel limit switch operation requires that **DInp1Pol** be set to Invert by the user to change the factory default.

**NOTE:** For S200 drives with the SynqNet option, the base drive INHIBIT+ function is turned off by **EnhibitCW** = Off. Over travel limit switch inputs must be wired directly to J13 on the SynqNet option card.

#### **DINP3 (INHIBIT-)**

**Input 3:** This input operates symmetrically to DINP2 with the INHIBIT- control function preventing further motion in the counter-clockwise shaft motion direction. This function can be turned on or off by setting **EnInhibitCCW**. **DInp3Pol** sets the control logic polarity.

#### **DINP4 (DIRECTION)**

**Input 4:** This input is the direction input when the drive is in Position Mode with the **PosCmdSrc** set to Step & Direction. Open circuit/no LED current positively increments the position command/motor goes CW. Set up time for direction is 100  $\mu$ s. Minimum pulse width is 200  $\mu$ s. Refer to **DInp4**.

### 6.7.1.2. DRIVING THE GENERAL PURPOSE INPUTS

#### **Sinking Logic**

For compatibility with sinking outputs, the DINP COM terminal is connected to the positive terminal of a power source (4.0 to 30 VDC). The input (DINP1-4) is connected to the sinking logic output of the field device as shown in the diagram below.

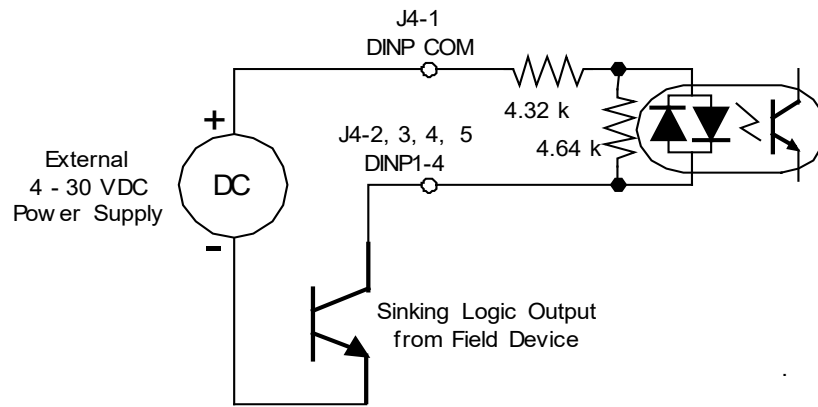

**Sourcing Logic**

For compatibility with sourcing outputs, the DINP COM terminal is connected to the negative terminal of the power source (4.0 to 30 VDC). The input (DINP1-4) is connected to the sourcing logic output on the field device as shown in the diagram below.

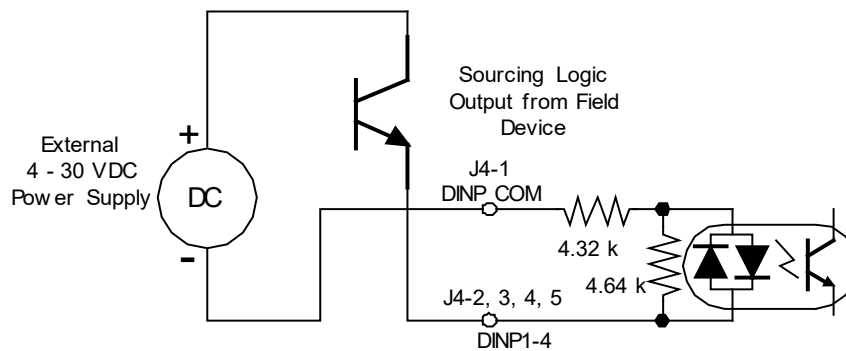

**TTL and CMOS Drivers**

The following are examples of driving with TTL or CMOS output devices.

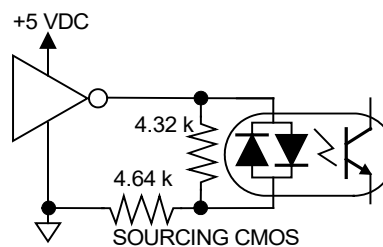
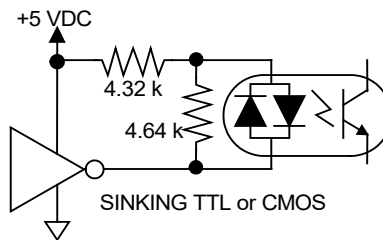

## 6.7.2 General Purpose Outputs

### General Purpose Outputs

DOUT1 and DOUT2 are optically isolated outputs that provide information about the state of the drive. The outputs are Darlington phototransistors with a 33 V zener diode wired in parallel to clamp voltage transients.

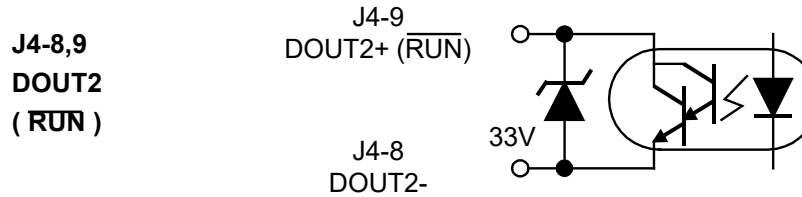
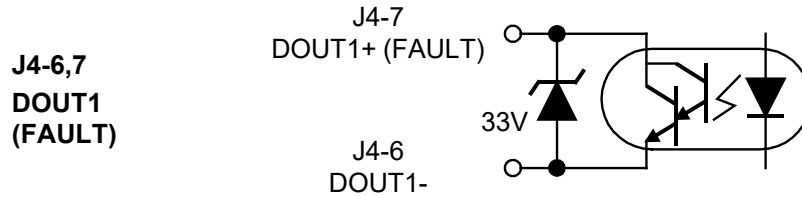

The following table lists the maximum output rating.

<b>Maximum Voltage</b>	30 VDC
<b>Maximum Current</b>	50 mA
<b>V<sub>ON</sub></b>	1.0 V at 10 mA
	1.2 V at 50 mA
<b>I<sub>OFF</sub></b>	5 $\mu$ A
<b>Response Time</b>	1 ms
<b>Clamp Voltage</b>	33 V (nominal)



*The outputs are not short circuit protected. Configure the application to ensure the maximum current is not exceeded.*

### 6.7.2.1. DEFAULT OUTPUT FUNCTIONS

The list below describes the factory defaults for each of the outputs.

**DOUT1 (FAULT)**      **Output 1:** This output provides the FAULT state of the drive. When the drive is powered and not faulted, the output transistor is turned ON. When the drive is faulted or not powered, the output transistor is turned OFF.

**DOUT2 (RUN)**      **Output 2:** This output provides the RUN state of the drive. When the drive is powered, not faulted and enabled, the output transistor is turned ON. When the drive is faulted, not enabled or not powered, the output transistor is turned OFF. This output indicates when the drive is capable of running the motor. This output can be used to drive a relay to turn a motor brake coil on and off.

### 6.7.2.2. OUTPUTS DRIVING TYPICAL LOADS

Both the collector and emitter of the phototransistor are on J4, providing the capability to drive either sinking or sourcing loads.

#### **Sinking Load**

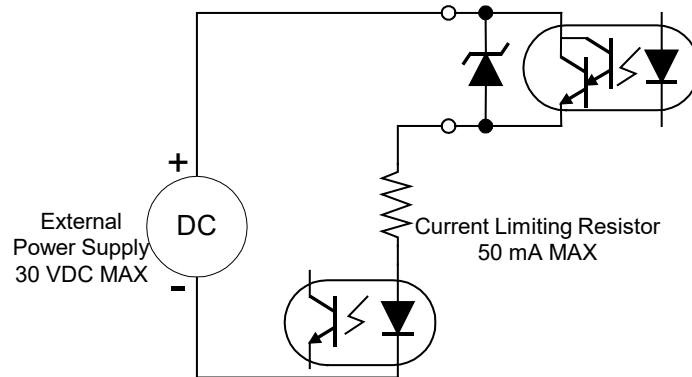

An optoisolator is being driven in this example. The current through the output needs to be limited to 50 mA or less, which is accomplished by selecting an appropriate current limiting resistor. The voltage of the external power source needs to be 30 VDC or less, and can be the same source used to provide power to the inputs.

#### **Sourcing Load**

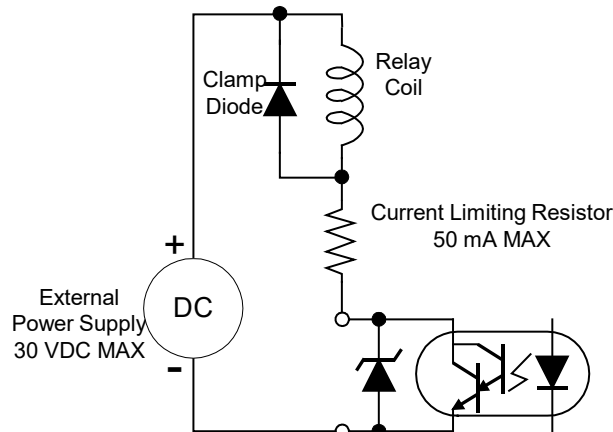

In this example, a relay coil is being driven. The current through the coil needs to be limited to 50 mA or less, which is accomplished by selecting an appropriate value of current limiting resistor.

The voltage of the external power source needs to be 30 VDC or less and can be the same source used to provide power to the inputs. A clamp diode must be added across the coil to clamp the voltage during turn-off.

## 6.7.3 High Speed Input

### High Speed Input

J4-10, 11

(Step or PWM)

The S200 has one high speed input for use with PWM input commands or with Step Input in Position Mode.

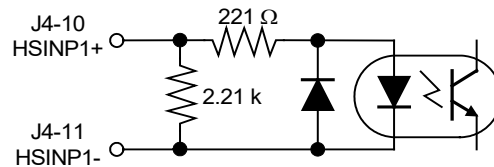

The high speed input works directly with 5 V input, 3.0 to 6.0 V range, without the use of a current limiting resistor. To operate the input with voltages higher than 5 V, an external current limiting resistor is required in series with the input. The input current should be in the range of 9 to 24 mA for proper operation. The following table lists the recommended current limiting resistors for supply voltages greater than 5 V.

Supply Voltage	Current Limiting Resistor
5 V	None
12 V	360 Ω, ¼ watt, resistor
24 V	1000 Ω, ½ watt, resistor

In Step-Dir Position Mode the transition edge from LED current to no LED current yields a step count. The transition edge from no LED current to LED current yields no action.



NOTE

**Maximum step frequency is 1.5 MHz**

**Minimum pulse width is 250 ns**



NOTE

**For single ended operation, it is recommended that both wires (J4-10 and J4-11) run in the cable be terminated at the control source (differential noise).**

### High Speed Input Differential Drive

A differential drive is recommended for the Step Input. To provide maximum noise immunity, drive the high speed input differentially from 5 V logic through twisted pair wiring. The differential driver needs to deliver a minimum of 3.0 V to the input terminals on J4. A CMOS driver is recommended.

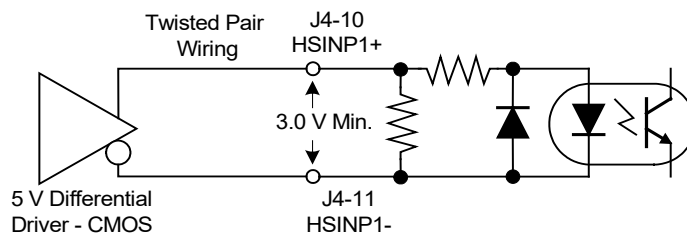

## Sinking Load

For single ended operation, both terminals of the high speed input are available on J4, allowing the input to be connected to either sinking or sourcing logic. The following diagram shows the connections to drive the high-speed input from sinking logic.

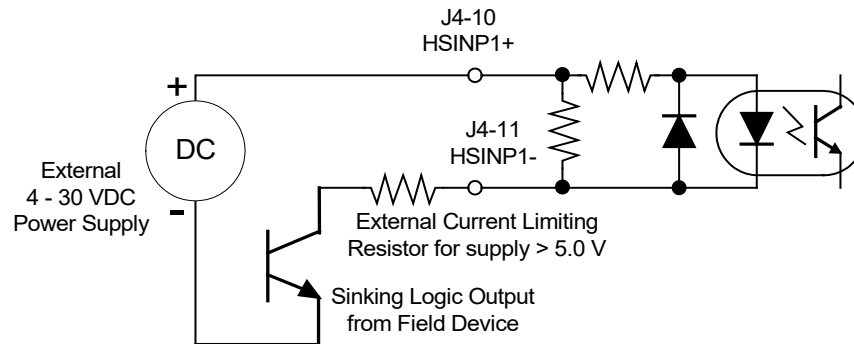

## Sourcing Load

The following shows the connections to drive the high-speed input from sourcing logic. The power supply can be the same power source used to provide power for the general purpose inputs.

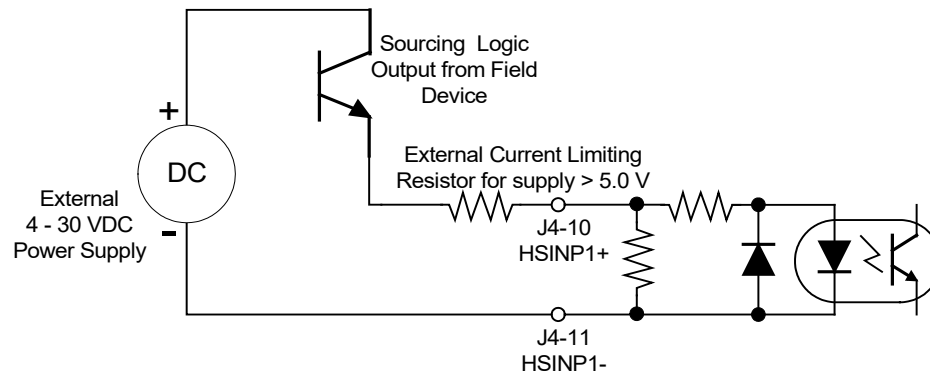

## 6.7.4 SFD BAT+

### J4-12 SFD BAT+

The SFD BAT+ terminal is an optional feature and is not required for proper operation of the drive. It is only required if battery backup of the multi-turn information is required from the SFD. If the feedback device is not an SFD, then the battery does nothing.

### J4-13 I/O RTN

The I/O RTN is the ground reference for the SFD BAT+ input.

## 6.7.5 DAC Monitors

### J4-14 DAC MON1

The DAC Monitors are general-purpose analog monitor points. The output range is 0.5 to 4.5 V with a source impedance of 2.9 k $\Omega$ , which limits the short circuit to I/O RTN to 2 mA. Each DAC Monitor can be mapped by software to one of a number of internal variables.

### J4-15 DAC MON2

### J4-13, 16, 23, 26 I/O RTN

I/O RTN is the ground reference for the DAC MON, Analog Command, Encoder output/inputs, and SFD BAT+. These pins are electrically shorted together inside the drive. These I/O RTN points are not connected to PE/chassis inside the drive except by small value EMI suppression capacitors. I/O RTN can float with respect to PE/chassis by up to  $\pm 50$  Vdc.

***One of these I/O RTN pins should connect to an earth ground point in the cabinet reserved for single point grounding of all returns (drives and supplies) to control common mode voltage.***

***Not connecting one of the I/O RTN pins to system common will cause electrical noise problems on signals.***

## 6.7.6 Encoder Outputs/Inputs

### J4-19 CH A OUT/IN

Channels A and B are RS-485 compliant differential I/O that can be configured as either inputs or outputs. Default is as outputs. When configured as outputs and with high resolution feedback such as the SFD device, Channels A and B provide position signals generated from the feedback device that emulate a quadrature encoder.

### J4-20 CH A OUT/IN

The outputs are buffered by 5.0 V, 75LBC170 type RS-422 compatible line drivers. Recommended load current is  $\pm 20$  mA, which corresponds to a line-to-line load resistance of 100  $\Omega$ . These outputs can handle shorts to I/O RTN indefinitely without damage.

### J4-21 CH B OUT/IN

The resolution of the Encoder Outputs (number of pulses per motor revolution), is set by S1 (rotary switch), as follows:

### J4-22 CH B OUT/IN

### Outputs



<b>S1 Position</b>	<b>Encoder Pulses/Revolution</b>
0	User settable <sup>1</sup> (factory default = 500)
1	512
2	1000
3	1024
4	2000
5	2048
6	4096
7	5000
8	8192
9	10000

<sup>1</sup>**User settable non-volatile PPR via the serial port. Possible PPR are:**

**128, 512, 1024, 2048, 4096, 8192,  
16384, 32768,  
125, 500, 1000, 2000, 2500, 5000,  
10000, 20000**

The maximum output line frequency is 2.5 MHz. Limit line frequency to below 1.25 MHz, which corresponds to quadrature count frequency below 5 MHz, for robust operation.

***The emulated encoder output is only available when using a high resolution feedback device such as the SFD feedback to the base unit or Encoder feedback to the option card. The emulated encoder outputs have no signals when there is only base unit 6-step feedback.***

Channels A and B can be configured as inputs by setting NV Parameter **PosCmdSrc** to AQUADB. With NV Parameter **OpMode** set to Position and **PosCmdSrc** to AQUADB, the motor shaft position command comes from the quadrature decode of channels A and B input scaled by the ratio of NV Parameters **GearOut** over **GearIn**. In Input mode, Channels A & B accept quadrature position commands. The command signals need to be differential quadrature signals. Channel A leading B generates a CW position command while Channel B leading A generates a CCW position command. The magnitude of the command position is set by **GearIn** and **GearOut**. The maximum input line frequency for reliable operation is 625 kHz, which corresponds to a maximum quadrature pulse rate of 2.5 MHz.

**J4-17, 18**  
**CH Z OUT**  
**CH Z OUT**

The CH Z Output is only available when using SFD Feedback. These two terminals function as a differential, TTL marker pulse. The output pulse occurs once per motor shaft revolution, starting at feedback device position = 0. Its width is one line width or two quadrature encoder widths. The CH Z uses the same differential driver as described for CH A and CH B.

**Encoder Phasing**

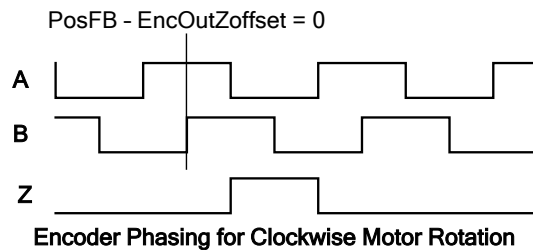

## 6.7.7 Analog Command Input

**ANA CMD**  
**J4-24, 25**  
**(+), (-) Inputs**

This differential input accepts the analog command from the user. It has a maximum single ended input range with respect to I/O RTN on either input of  $-12.5$  to  $+15.5$  VDC, a differential input impedance of  $> 300$  k $\Omega$ , and a single ended impedance of  $> 150$  k $\Omega$ . The recommended full-scale differential command input range is  $\pm 10$  V, but the input can handle up to  $\pm 12$  V to accommodate noise and overshoot spikes. Default setup has  $\pm 10$  V corresponding to  $\pm I_{peak}$  or  $\pm$  maximum velocity depending on the OpMode.

The offset, gain (including polarity), and low pass filter bandwidth of this input are set by the following NV Parameters: **CmdGain**, **CmdOffset**, and **CmdF0** respectively and can be adjusted by the PC setup software. Defaults are  $\pm 10$  V range, 0 offset, 1500 Hz bandwidth. Positive ANA CMD yields clockwise torque when looking at the shaft at the front of the motor.

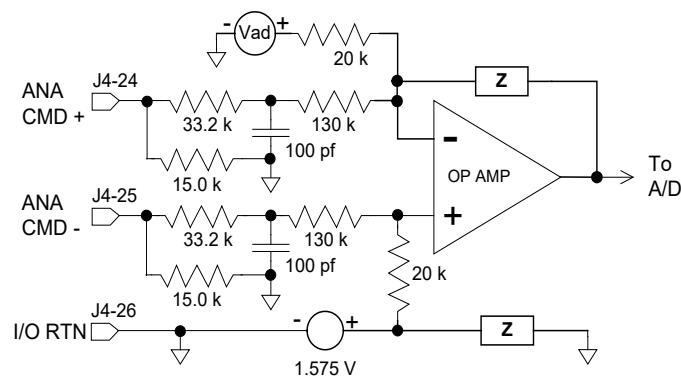

Always connect I/O RTN (J4-26) to the signal ground of the source. Failure to do so may result in erratic operation.



**NOTE**

Both J4-24 and J4-25 need to be wired. For single ended operation connect the unused input to the signal ground of the source. Best signal fidelity uses a separate wire all

the way back to the source for the unused input connection to the source's signal ground.

The direction of rotation of the motor can be changed by swapping the ANA CMD input connections or changing the sign of the CmdGain NV Parameter.

## 6.8 J5 – SERIAL PORT CONNECTOR

J5 a 6-pin RJ-12/RJ-11 connector provides RS-232 serial communication to the drive. The RS-232 transceiver is an industry standard RS-232 configuration using the MAX3221.

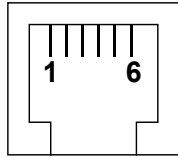

(J5 Connector view from front of drive)

Pin	Description
J5-1	No Connection
J5-2	RX232
J5-3	I/O RTN
J5-4	I/O RTN
J5-5	TX232
J5-6	No Connection

### Mating Connector Information

RJ12/RJ11 – Phone Style -Standard RJ12/RJ11 plug

- J5-1, J5-6  
No Connection** These terminals are not used or connected to the drive.
- J5-2  
RX232** RS-232 receiver input to the drive. This terminal connects to the user's RS-232 transmitter output.
- J5-3, J5-4  
I/O RTN** These terminals are the common/ground connection for the RS-232 serial port. The ground from the user's RS-232 needs to connect to this terminal. Cable shielding is also connected to this point.
- J5-5  
TX232** RS-232 Transmitter output from the drive. This terminal connects to the user's RS-232 receiver input.



CAUTION

**Do NOT use the serial connector/cable when using an S200 SynqNet Series Drive. SynqNet cables, not a serial cable, should be used for communication between the drive and SynqNet motion controller. If you connect to an S200 SynqNet Series Drive using a serial cable and select 'Serial' instead of 'SynqNet' as the Communications Mode in the S200Tools Communication Wizard, the drive will appear configured in the interface, but the SynqNet Options tab will not appear under the Drive Setup options.**

### 6.8.1.1. STATUS LED

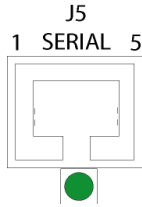

The Status LED is located below the Serial Port connector located at J5. Please see the Drive Fault Codes section for descriptions.

### 6.8.2 Serial Interface Specification

Parameter	Specification
Baud rate	19,200
Electrical Interface	RS-232, Full duplex
Transfer format	UART, 1 start bit (mark), 8 data bits, odd parity bit and 1 stop bit (space).

### 6.8.3 RS-232 Wiring

Cable wiring diagrams for connecting to either 9 or 25-pin serial ports of most computers are also shown.



**NOTE**

***Pinouts vary among computer manufacturers. Check the hardware reference manual for your machine before wiring.***

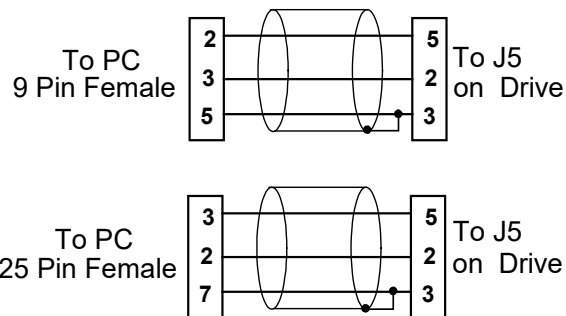

## 6.9 SYNQNET OPTION CARD WIRING

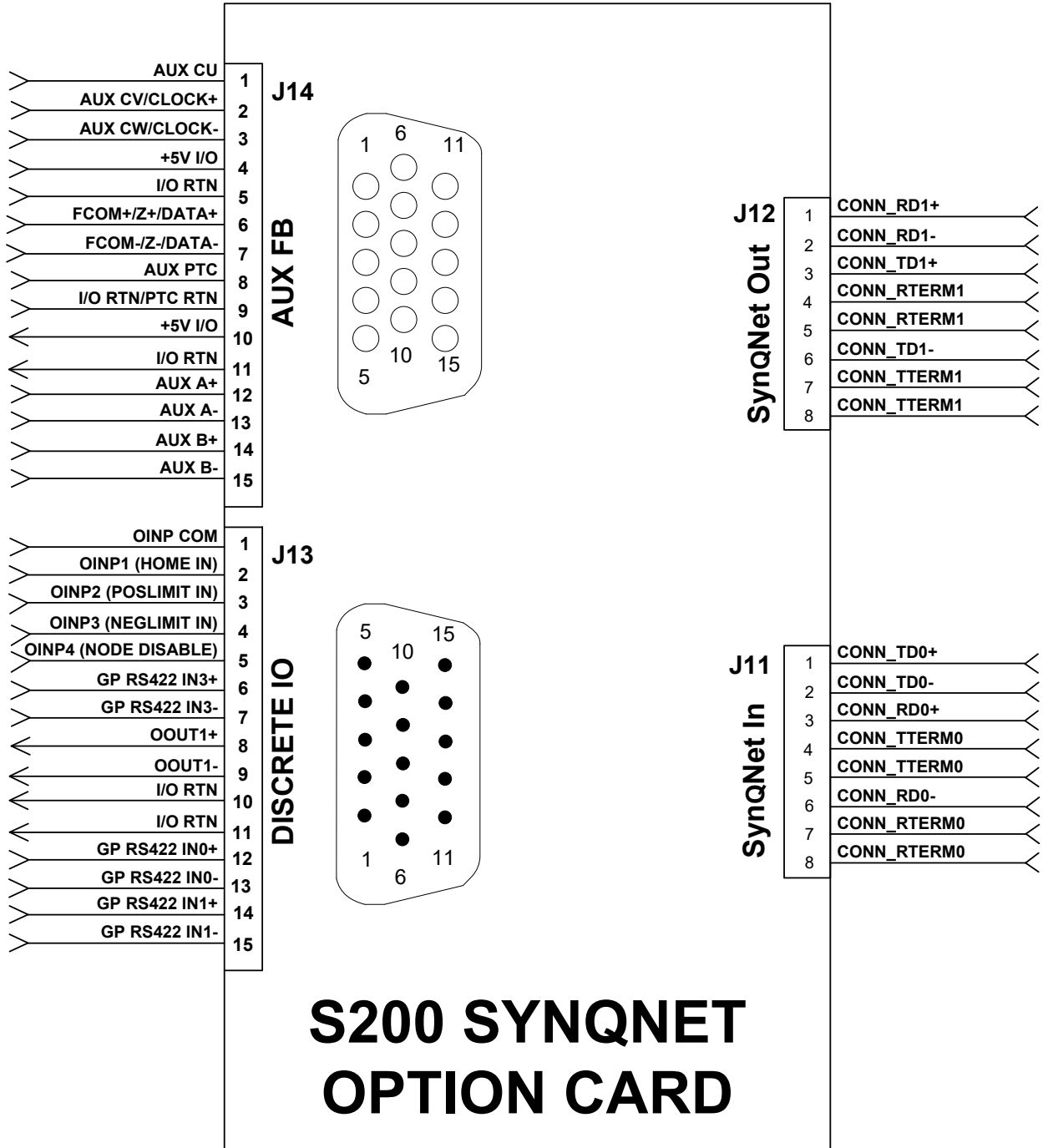

## 6.10 J11 – SYNQNET IN PORT CONNECTOR

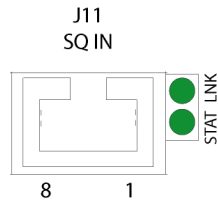

J11 is a Standard CAT5 connector.

(J11 Connector view from front of drive.)

Pin	Description
J11-1	CONN_TD0+
J11-2	CONN_TD0-
J11-3	CONN_RD0+
J11-4	CONN_TTERM0
J11-5	CONN_TTERM0
J11-6	CONN_RD0-
J11-7	CONN_RTERM0
J11-8	CONN_RTERM0
-	SHLD

UUP1 and UUP2 are "unused pair" 1 and 2. When using a standard CAT5 cable, these pairs are connected to the two unused pairs in the 4 pair (8 wire) cable.

NOTE: Standard CAT5 design practice is to terminate these pairs on the PCB to reduce noise. When using a 2 pair cable, these pins are left unconnected in the cable.

### Mating Connector Information

#### Unshielded:

8-Pin Male PN 6-557315-2 (AKA MP-88U-R-5): bag of 500 pcs.

8-Pin Male PN 6-557315-3 (AKA MP-88U-R-1): bag of 100 pcs.

#### Shielded:

8-Pin Male PN 6-569550-2 (AKA MP-5ES-5): bag of 500 pcs.

8-Pin Male PN 6-569550-3 (AKA MP-5ES-1): bag of 100 pcs.

### 6.10.1 SynqNet LEDs

Pin	Meaning	Description
STAT	Network Status Activity	ON = Tx and Rx active (cyclic phase)
		BLINK = Tx only active (discovery phase)
		OFF = Idle (shutdown phase)
LNK	Link Activity	ON = Link Active
		OFF = Link Inactive

## 6.11 J12 – SYNQNET OUT PORT CONNECTOR

J12  
SQ OUT

J12 is a Standard CAT5 connector.

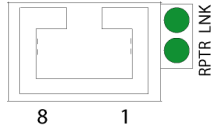

(J12 Connector view from front of drive.)

Pin	Description
J12-1	CONN_RD1+
J12-2	CONN_RD1-
J12-3	CONN_TD1+
J12-4	CONN_RTERM1
J12-5	CONN_RTERM1
J12-6	CONN_TD1-
J12-7	CONN_TTERM1
J12-8	CONN_TTERM1
-	SHLD

UUP1 and UUP2 are "unused pair" 1 and 2. When using a standard CAT5 cable, these pairs are connected to the two unused pairs in the 4 pair (8 wire) cable.

NOTE: Standard CAT5 design practice is to terminate these pairs on the PCB to reduce noise. When using a 2 pair cable, these pins are left unconnected in the cable.

### Mating Connector Information

#### Unshielded:

8-Pin Male PN 6-557315-2 (AKA MP-88U-R-5): bag of 500 pcs.

8-Pin Male PN 6-557315-3 (AKA MP-88U-R-1): bag of 100 pcs.

#### Shielded:

8-Pin Male PN 6-569550-2 (AKA MP-5ES-5): bag of 500 pcs.

8-Pin Male PN 6-569550-3 (AKA MP-5ES-1): bag of 100 pcs.

### 6.11.1 SynqNet LEDs

Pin	Meaning	Description
RPTR	Repeater	ON = Repeater on, network cyclic
		BLINK = Repeater on, network not cyclic
		OFF = Repeater off, power off, or reset
LNK	Link Activity	ON = Link Active
		OFF = Link Inactive

## 6.12 J13 – DISCRETE I/O CONNECTOR

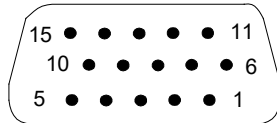

J13 is a Standard D-Sub 15-pin Male connector.

(J13 Connector view from front of drive.)

Pin	Description
J13-1	OINP COM
J13-2	OINP1 (HOME IN)
J13-3	OINP2 (POSLIMIT IN)
J13-4	OINP3 (NEGLIMIT IN)
J13-5	OINP4 (NODE_DISABLE)
J13-6	GP RS422 IN3+
J13-7	GP RS422 IN3-
J13-8	<b>OOUT1+</b>
J13-9	<b>OOUT1-</b>
J13-10	I/O RTN
J13-11	I/O RTN
J13-12	GP RS422 IN0+
J13-13	GP RS422 IN0-
J13-14	GP RS422 IN1+
J13-15	GP RS422 IN1-

### Mating Connector Information

15-Pin Female High Density D-Sub

NorComp 180-015-202-001 – Female D-Sub connector solder

NorComp 978-009-020-121 – Metalized plastic back shell kit

**Refer to [www.norcomp.net](http://www.norcomp.net).**

The optically isolated digital I/O on connector J13 is based on the exact same circuitry used on the base unit on connector J4. For detailed electrical specifications and information on how to interface to this I/O refer to Sections 6.7.1 **General Purpose Inputs** and 6.7.2 **General Purpose Outputs**.

J13 also includes 3 channels of very fast RS-422 compatible direct coupled differential digital inputs that can be used for very high speed registration or probing functions.





## 6.13 J14 – AUX FB CONNECTOR

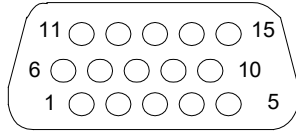

J14 is a Standard D-Sub 15-pin Female connector.

(J14 Connector view from front of drive.)

Pin	Description
J14-1	AUX CU
J14-2	AUX CV/CLOCK+
J14-3	AUX CW/CLOCK-
J14-4	+5V I/O
J14-5	I/O RTN
J14-6	FCOMZ+ / DATA+
J14-7	FCOMZ- / DATA-
J14-8	<b>AUX PTC</b>
J14-9	I/O RTN
J14-10	+5V I/O
J14-11	I/O RTN
J14-12	AUX A+
J14-13	AUX A-
J14-14	AUX B+
J14-15	AUX B-

### Mating Connector Information

15-Pin Female High Density D-Sub

NorComp 180-015-102-001 – Male D-Sub connector solder

NorComp 978-009-020-121 – Metalized plastic back shell kit

Refer to [www.norcomp.net](http://www.norcomp.net).

### 6.13.1 Auxiliary Feedback Device Port

Run	FB	Type
	X	Incremental Encoder
X	X	Incremental Encoder + Halls AKM Motor Feedback Options:ED, EE, DF, EG, EM, EH, EN, EJ
	X	1 Vp-p Sin-Cos 65536x Interpolator
X	X	1 Vp-p Sin-Cos 65536x Interpolator + Halls
X	X	EnDat 2.1 Sin-Cos Encoder Single-turn absolute AKM Motor Feedback Option DA or other EnDat 2.1
X	X	EnDat 2.1 Sin-Cos Encoder Multi-turn Absolute AKM Motor Feedback Option DB or other EnDat 2.1
X	X	EnDat 2.2 Encoders operating in 2.1 compatibility mode both rotary and linear including absolute types

**Run** - Commutate the motor and close the servo loops.

**FB** - Use as a secondary feedback to SynqNet master.

## 6.13.2 Auxiliary Feedback Sin-Cos Interpolation Scaling

The J14 1 Vp-p analog Sin-Cos feedback interface has a 65536x (16 bit) interpolator that is followed by a programmable scalar to create the final measured position in counts. The following diagram shows the scaling path. When J14 is used as an Auxiliary or second feedback the user is free to select whatever value for the scaling parameter AuxFBDivisor best suits the application. However, if the NV parameter FBSrc is set to Option Card, then AuxFBDivisor must be set to the specific value which will properly electronically commutate the motor work.

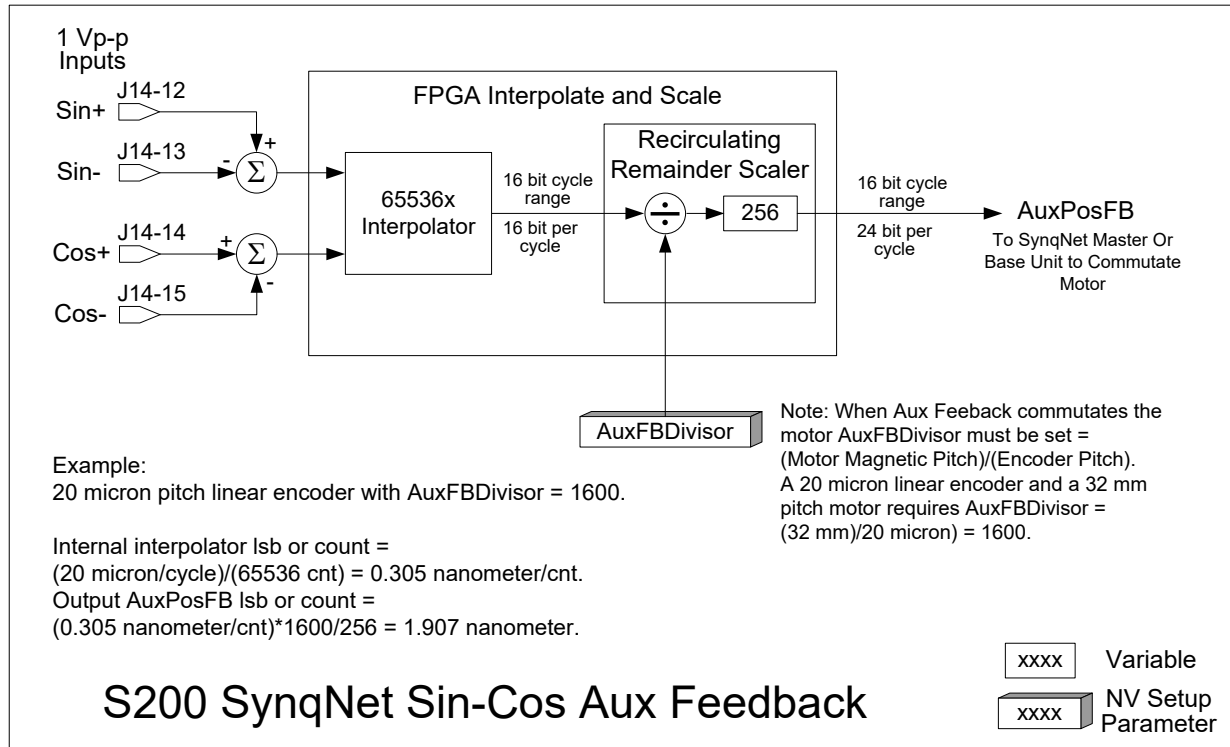

## 7 BASIC CONFIGURATION

When connected to a motor equipped with the Smart Feedback Device (SFD), the S200 drive will automatically configure most of its operating parameters. For many applications requiring an analog torque or analog velocity block, no additional set up beyond the setting of the two switches is required to fully commission the drive. For such cases, connection to a computer to commission the drive is not required. The quick setup is useful for simplifying machine field upgrades/repairs and for reducing spare part inventory. See Configuring with SFD Feedback.

The drive can also be configured for a simple analog Torque/Current control with 6-Step (Hall) Feedback type by simply setting the switches. See Configuring Current Mode with 6-Step (Hall) Feedback.

The S200 drive has many advanced capabilities to aid machine design through its diagnostic and measurement capabilities accessed through the Windows compatible S200Tools GUI utility. The drive also has many advanced motion capabilities that can be set up through the S200Tools utility. For example, if desired, the settings of the switches can be overridden in drive non-volatile memory to eliminate any accidental miss-adjustment of the drive in the field. See the Advanced Configuration section for more details.

### 7.1 SWITCH SETTINGS

The configuration switches S1 and S2 are located on the top of the drive. Although the drive can be configured to not use the switches, the factory default configuration uses the switches for selecting Torque/Current versus Velocity operational mode, SFD or 6-step feedback device, and emulated encoder line count.

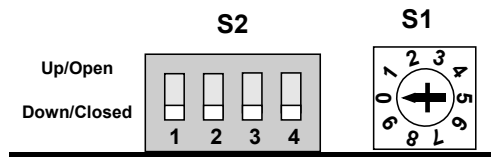

#### 7.1.1 S2 - DIP Setup Switch

S2 is a 4-position DIP switch. Switch positions 1 and 2 can set the operational mode and feedback types when enabled. Setting the drive parameters as shown in the following table enables the switch and is the factory default configuration. Switch positions 3 and 4 are reserved for future functionality and should be left in the down/closed factory default position.

Switch Position	Parameter Setting	Function	Switch State	
			Down/Closed	Up/Open
S2-1	<b>OpMode</b> = SetupS2-1	Operational Mode	Torque/Current Control	Velocity Control
S2-2	<b>CommMode</b> = SetupS2-2	Feedback Type	SFD	6-Step
S2-3		Reserved	Default	Reserved
S2-4		Reserved	Default	Reserved

**Drive parameter settings can override the S2 switch settings. To enable S2 for setup verify that the following drive parameters are set as shown below. The factory default is to ship the drive with the switches enabled:**



NOTE

Parameter	Value
<b>OpMode</b>	SetupS2-1
<b>CommMode</b>	SetupS2-2

## 7.1.2 S1 - Rotary Setup Switch

Switch S1 is a 10-position rotary switch. The function of switch S1 depends on the feedback mode in which the drive is configured.

### 7.1.2.1. S1 FUNCTION WITH SFD FEEDBACK

When using the Smart Feedback Device (SFD), S1 sets the emulated encoder line count.

S1 Position	Emulated Encoder Lines/Revolution	S1 Position	Emulated Encoder Lines/Revolution
0	User settable <sup>1</sup> (factory default = 500)	5	2048
1	512	6	4096
2	1000	7	5000
3	1024	8	8192
4	2000	9	10000

<sup>1</sup>**S1 position 0 allows setting the non-volatile line count via the drive parameter *EncOut* to any of the following values:**

**128, 512, 1024, 2048, 4096, 8192, 16384, 32768**

**125, 500, 1000, 2000, 2500, 5000, 10000, 20000**

**The value written replaces the factory default value listed in position 0 of the table.**



NOTE

**The emulated encoder output is only available when using SFD feedback to the base unit or a high-resolution feedback device connected to the option card.**

### 7.1.2.2. S1 FUNCTION WITH 6-STEP FEEDBACK

In 6-step mode, S1 sets the current loop proportional gain, KIP. Set S1 to the value listed in the table for your drive type and motor inductance. Consult the factory if the motor inductance is lower or higher than what can be accommodated by S1. An incorrect setting of KIP can cause current loop instability or oscillation potentially resulting in damage to the drive or application.

Motor Inductance Table for 6-Step Commutation (L in mH)					
AC Input Drive			DC Input Drive		S1
S20260	S20360	S20660	S20330	S20630	Position
User Settable <sup>1</sup> (factory default = 96.932)	User Settable <sup>1</sup> (factory default = 48.416)	User Settable <sup>1</sup> (factory default = 24.208)	User Settable <sup>1</sup> (factory default = 12.104)	User Settable <sup>1</sup> (factory default = 6.052)	0 <sup>1</sup>
6.17 - 9.03	3.09 - 4.50	1.55 - 2.25	0.52 - 0.75	0.27 - 0.38	1
9.04 - 13.39	4.51 - 6.69	2.26 - 3.34	0.76 - 1.11	0.39 - 0.56	2
13.40 - 19.56	6.70 - 9.78	3.35 - 4.89	1.12 - 1.63	0.57 - 0.81	3
19.57 - 28.89	9.79 - 14.44	4.90 - 7.22	1.64 - 2.41	0.82 - 1.20	4
28.90 - 43.34	14.45 - 21.67	7.23 - 10.83	2.42 - 3.61	1.21 - 1.80	5
43.35 - 63.80	21.68 - 31.90	10.84 - 15.95	3.62 - 5.32	1.81 - 2.65	6
63.81 - 95.11	31.91 - 47.55	15.96 - 23.76	5.33 - 7.92	2.66 - 3.96	7
95.12 - 144.49	47.56 - 72.24	23.77 - 36.12	7.93 - 12.04	3.97 - 6.02	8
144.50 - 216.74	72.25 - 108.4	36.13 - 54.20	12.05 - 18.06	6.03 - 9.03	9

<sup>1</sup>S1 position 0 allows setting the non-volatile KIP via the serial port to any valid value in 6-Step mode. The value written will replace the default value listed in position 0 of the table.

### 7.1.3 S11, S12 - Rotary SynqNet ID Switches

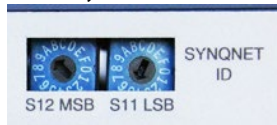

The SynqNet ID switches can be used to help distinguish and differentiate a drive on the network by assigning a unique ID to the drive.

To set a SynqNet ID to an S200 drive, turn the S11 LSB (Least Significant Bit) and S12 MSB (Most Significant Bit) switches to a desired letter/number combination.

The SynqNet ID can then be read using the following utilities: Motion Console and Version.exe Utility.

### 7.1.3.1. MOTION CONSOLE

In the SqNode Summary window, under the Info tab, the SynqNet ID is displayed in the Switch ID field. See screenshot below.

#### SYNQNET ID

S11 = 5  
S12 = A

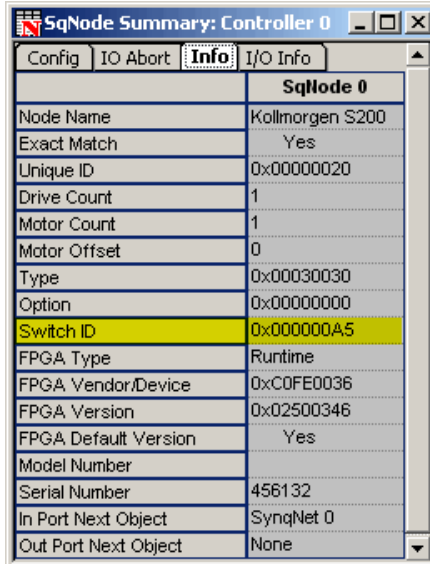

### 7.1.3.2. VERSION.EXE UTILITY

The version.exe utility also displays the Switch ID field. See screenshot below.

#### SYNQNET ID

S11 = 5  
S12 = A

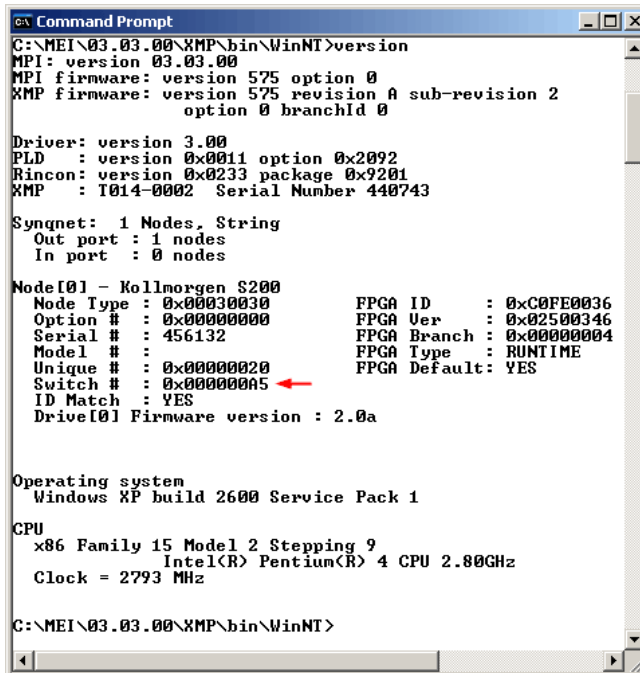

## 7.2 CONFIGURING FOR BRUSH MOTORS



With a SynqNet option card the S200 Drive must be set with **FBSrc = Base Unit**.

To drive a brush motor connect to the S200 as shown below.

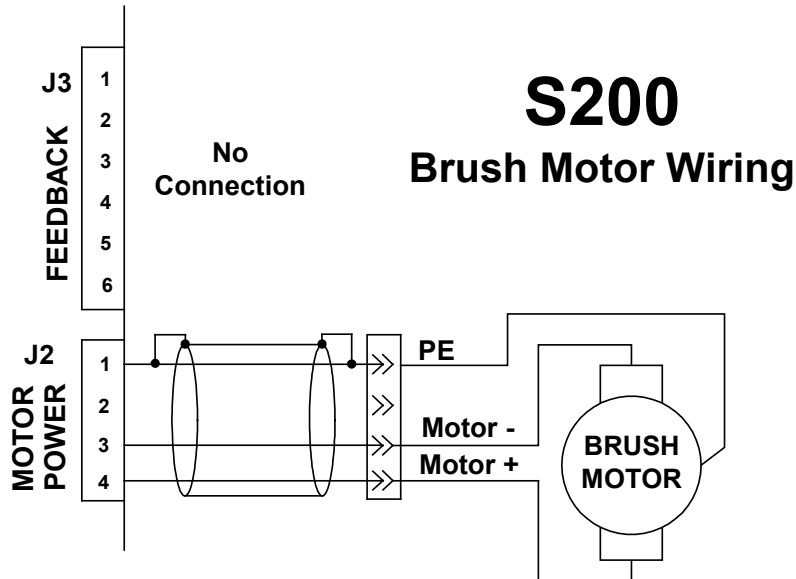

To finish configuring the S200 to drive a brush motor, set the following parameters using the S200Tools utility. Once configured, the parameters should be saved to non-volatile MEMORY (click the NV Save button). The configuration will then be recalled on drive power up. Refer to Advanced Configuration for detailed descriptions of the parameters. The relevant parameters are listed in the table below.

Parameter	Value
<b>CommMode</b>	Brush
<b>CommOff</b>	0 Degrees
<b>OpMode</b>	Torque/Current <i>Or</i> SetupS2-1 with switch S2-1 set to the down position labeled, I on the drive.
<b>KIP</b>	Set directly with the serial port when S1 is set to position 0. <i>Or</i> Set S1 to the appropriate position for the inductance of the motor be used, refer to S1 Function with 6-Step Feedback.
<b>I2TF0</b>	Set to the motor's thermal time constant.
<b>I2TTrip</b>	Set to the motor's continuous current rating.
<b>IImtPlus</b> <b>ILmtMinus</b>	Set to the lower of 100% or the percent of the motor's peak current rating divided by the drives peak current.
<b>CmdSrc</b>	Selects Analog, PWM, or Command variable for command.
<b>CmdGain</b>	Sets the command gain for the command input.
<b>CmdOffset</b>	Sets the command offset for the command input.
<b>CMDFO</b>	Sets the filtering on analog input commands.
<b>EnInhibitCW</b> <b>EnInhibitCCW</b>	Enables the hardware over travel limits.



## 7.3 CONFIGURING WITH 6-STEP (HALL) FEEDBACK

### 7.3.1 6-Step Feedback Wiring

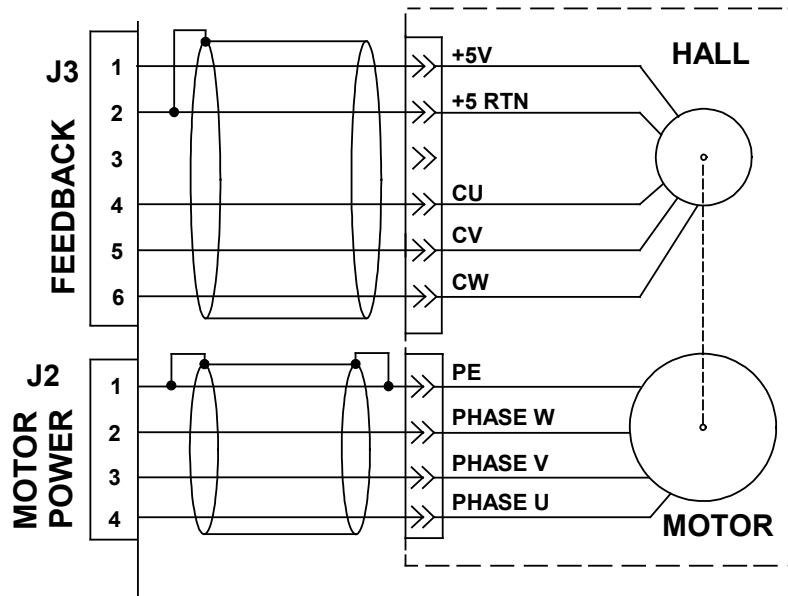

## 7.3.2 6-Step Torque/Current Mode

In 6-Step mode with Hall or Hall equivalent feedback, the drive can be configured either using the S200Tools utility or the S1 and S2 switches. Configuring the drive with the S200 Tools provides the advantage of setting the drive's current limits and motor thermal protection. When using S200Tools the configuration parameters should be saved to non-volatile memory to allow the configuration to be recalled on power up.

To configure the drive for 6-Step feedback set the following parameters:

Parameter	Value
<b>CommMode</b>	SetupS2-2 (Default value) with switch S2-2 set to the up position labeled, <b>6</b> on the drive. <i>or</i> 6-Step
<b>CommOff</b>	<b>0 Degrees (Default value)</b>
<b>OpMode</b>	SetupS2-1 (Default value) with switch S2-1 set to the down position labeled, <b>1</b> on the drive. <i>or</i> Torque/Current
<b>KIP</b>	Set directly with the serial port when S1 is set to position 0 <i>or</i> Set S1 to the appropriate position for the inductance of the motor to be used, refer to Configuring Current Mode with 6-Step (Hall) Feedback.
<b>I2TF0</b>	Set to the motor's thermal time constant.
<b>I2TTrip</b>	Set to the motor's continuous current rating.
<b>ILmtPlus</b> <b>ILmtMinus</b>	Set to the lower of 100% or the percent of the motor's peak current rating divided by the drives peak current.
<b>CmdSrc</b>	Sets the source of the command, analog or command variable.
<b>CmdGain</b>	Sets the command gain for the command input.
<b>CmdOffset</b>	Sets the command offset for the command input.
<b>CmdF0</b>	Sets the filtering on analog input commands.

The following are optional parameters that can be set.

Parameter	Function
<b>EncOut</b>	<b>Sets the line count of the emulated encoder output. With 6-Step feedback the emulated encoder output works by interpolating between the edges. So, at low speeds signal quality will be poor.</b>
<b>EnInhibitCW</b> <b>EnInhibitCCW</b>	<b>Enables the hardware over travel limits.</b>

### 7.3.3 6-Step Velocity Mode

In 6-Step mode with Hall or Hall equivalent feedback, the drive can be configured to control shaft velocity. But, because of the coarse resolution of 6-Step feedback the velocity bandwidth and smoothness will not be as good as other feedback options.

To configure the drive for 6-Step feedback Velocity mode set the following parameters:

Parameter	Value
<b>CommMode</b>	SetupS2-2 (Default value) with switch S2-2 set to the up position labeled, <b>6</b> on the drive. <i>or</i> 6-Step
<b>CommOff</b>	<b>0 Degrees (Default value)</b>
<b>OpMode</b>	Velocity <i>or</i> SetupS2-1 with switch S2-1 set to the up position labeled, <b>V</b> as shown on the drive.
<b>ARF0</b> <b>ARF1</b>	Single pole filters in the velocity loop forward path. Set to accommodate the effects of mechanical resonance
<b>KVI</b>	Sets the velocity loop break out frequency from integral to proportional compensation.
<b>CmdSrc</b>	Selects Analog, PWM, or Command variable for command.
<b>CmdGain</b>	Sets the command gain for the command input.
<b>CmdOffset</b>	Sets the command offset for the command input.
<b>CmdF0</b>	Sets the filtering on analog input command.

The following are optional parameters that can be set.

Parameter	Function
<b>EncOut</b>	Sets the line count of the emulated encoder output. With 6-Step feedback the emulated encoder output works by interpolating between the edges. So, at low speeds signal quality will be poor.
<b>EnInhibitCW</b> <b>EnInhibitCCW</b>	Enables the hardware over travel limits.

## 7.4 CONFIGURING WITH SFD FEEDBACK

### 7.4.1 SFD Motor Parameters

When the drive is powered up and connected to a motor with SFD feedback, the drive will automatically configure itself for the attached motor by loading the default motor parameters. The default motor parameters provide robust performance of current and velocity loops with optimized settings to protect the motor from thermal overload. For most applications, these default motor parameter settings are recommended because they provide excellent performance and require no additional tuning. To use the default motor parameters verify that **SelSFDParam** is set to **SFD**, which is the factory default setting.

If the response time and/or stability of the system needs to be further optimized for the specific application, the motor parameters will need to be modified. To modify the motor parameters, set **SelSFDParam** to **Drive**. This setting unlocks the motor parameters and allows the parameters to be individually set with the S200Tools utility. The modified motor parameters will need to be saved to the drive's non-volatile memory (click the NV Save button) to ensure that the changed settings are loaded when the drive is powered up.

*Incorrect motor parameter settings can cause damage to the motor and/or drive.*

*The motor parameters need to be set correctly to match the drive to the motor. The correct parameter settings ensure:*



CAUTION

- *The drive is matched to the motor inductance and pole count.*
- *The current and velocity loops are stable with good bandwidth.*
- *The motor is protected from thermal overload.*

*A good starting point to setting the motor parameters is to obtain the default motor parameters and then edit only the parameters that need to be changed*



NOTE

- *Using the S200 Tools, set SelSFDParam to SFD, this loads the default motor parameters.*
- *Next, set SelSFDParam to DRIVE. This will allow the motor parameters to be edited. Change only the parameters you are looking to optimize.*
- *When finished setting the motor parameters (and any other parameters), save the parameters to NV Memory by clicking the NV Save button.*

The following drive setup parameters controlled by SelSFDParam:

Parameter	Value
<b>KVP</b>	Velocity loop proportional gain.
<b>KIP</b>	Current loop proportional gain.
<b>DPoles</b>	Drive pole pairs.
<b>I2TF0</b>	Speed of response for motor transient thermal protection.
<b>I2TTrip</b>	Fault trip level for motor transient thermal protection.
<b>IImtPlus, IImtMinus</b>	Clamps drive maximum lout based on motor Ipeak.

## 7.4.2 SFD Torque/Current Mode

The S200 can drive a brushless motor in Torque/Current Mode using SFD Feedback. The drive can be configured either with the S200Tools over the serial port or configured using the S1 and S2 switches. Configuring the drive with the S200Tools utility provides increased flexibility in setting parameters that are not available through the setup switches. When using the S200Tools utility, the configuration parameters should be saved to non-volatile memory (click the NV Save button) to allow the configuration to be recalled on power up.

To configure the drive for Current Mode with SFD feedback, set the following parameters:

Parameter	Value
<b>CommMode</b>	SetupS2-2 (Default value) with switch S2-2 set to the down position labeled, <b>S</b> on the drive. <i>or</i> SFD
<b>CommOff</b>	0 Degrees – for AKM motor series, check with your sales representative for the correct commutation offset angle for other motor series.
<b>OpMode</b>	SetupS2-1 with switch S2-1 set to the down position labeled, <b>I</b> , on the drive. <i>or</i> Current
<b>SelSFDParam</b>	SFD (Default value) – recommended setting. This setting will automatically set the motor parameters. To change motor parameters refer to Configuring with SFD Feedback Motor Parameters.
<b>CmdSrc</b>	Sets the source of the command.
<b>CmdGain</b>	Sets the command gain for the command input.
<b>CmdOffset</b>	Sets the command offset for the command input.
<b>CMDFO</b>	Sets the filtering on analog input commands.

The following are optional parameters that can be set.

Parameter	Function
<b>EncOut</b>	<b>Sets the line count of the emulated encoder output.</b>
<b>EnInhibitCW</b> <b>EnInhibitCCW</b>	<b>Enables the hardware over travel limits.</b>

## 7.4.3 SFD Velocity Mode

The S200 can drive a brushless motor in Velocity Mode using SFD Feedback. The drive can be configured either with the S200 tools over the serial port or configured using the S1 and S2 switches. Configuring the drive with the S200Tools utility provides increased flexibility in setting parameters that are not available through the setup switches. When using the S200Tools utility, the configuration parameters should be saved to non-volatile memory (click the NV Save button) to allow the configuration to be recalled on power up.

To configure the drive for SFD feedback set the following parameters:

Parameter	Value
<b>CommMode</b>	SetupS2-2 (Default value) with switch S2-2 set to the down position labeled, <b>S</b> on the drive. <i>or</i> SFD
<b>CommOff</b>	0 Degrees – for AKM motor series. Check with your sales representative for the correct commutation offset angle for other motor series.
<b>OpMode</b>	Velocity <i>or</i> SetupS2-1 with switch S2-1 set to the up position labeled, <b>V</b> as shown on the drive.
<b>SeISFDParam</b>	SFD (Default value) – recommended setting This setting automatically sets the motor parameters. <b>KVP</b> is set for 75 Hz nominal velocity loop bandwidth with an unloaded motor. To change <b>KVP</b> or other motor parameters, refer to Configuring with SFD Feedback Motor Parameters.
<b>ARF0</b> <b>ARF1</b>	Single pole filters in the velocity loop forward path. Set to accommodate the effects of mechanical resonance
<b>KVI</b>	Sets the velocity loop break out frequency from integral to proportional compensation.
<b>CmdSrc</b>	Selects Analog, PWM, or Command variable for command.
<b>CmdGain</b>	Sets the command gain for the command input.
<b>CmdOffset</b>	Sets the command offset for the command input.
<b>CmdF0</b>	Sets the filtering on analog input command.

The following are optional parameters that can be set.

Parameter	Function
<b>EncOut</b>	<b>Sets the line count of the emulated encoder output.</b>
<b>EnInhibitCW</b> <b>EnInhibitCCW</b>	<b>Enables the hardware over travel limits.</b>

## 7.4.4 SFD Position Mode

The base S200 can drive a motor in Position Mode using SFD Feedback. The source of the command can either be Step and Direction, or A,B differential quadrature signals. The drive needs to be configured using the S200Tools utility. The configuration parameters should be saved to non-volatile memory (click the NV Save button) to allow the configuration to be recalled on power up.

To configure the drive for SFD feedback set the following parameters:

Parameter	Value
<b>CommMode</b>	SetupS2-2 (Default value) with switch S2-2 set to the down position labeled, <b>S</b> on the drive. <i>or</i> SFD
<b>CommOff</b>	0 Degrees – for AKM motor series. Check with your sales representative for the correct commutation offset angle for other motor series.
<b>OpMode</b>	Position
<b>PosCmdSrc</b>	Selects the source of the command, either Step-Dir or AquadB.
<b>GearIn GearOut</b>	Sets the distance the shaft moves for each input position command pulse/count.
<b>KPP</b>	Sets the proportional gain of the position loop.
<b>KVFF</b>	Sets the feed forward gain of the derivative or the position command to the internal velocity command.
<b>SeISFDParam</b>	SFD (Default value) – recommended setting This setting will automatically set the motor parameters. <b>KVP</b> will be set for 75 Hz nominal velocity loop bandwidth with an unloaded motor. To change <b>KVP</b> or other motor parameters refer to Configuring with SFD Feedback Motor Parameters.
<b>KVI</b>	Sets the velocity loop break out frequency from integral to proportional compensation.
<b>ARF0 ARF1</b>	Single pole filters in the velocity loop forward path. Set to accommodate the effects of mechanical resonance.

The following are optional parameters that can be set.

Parameter	Function
<b>EncOut</b>	Sets the line count of the emulated encoder output. <b>NOTE:</b> Emulated Encoder Outputs are not available when the PosSrcCmd is set to AquadB.
<b>EnInhibitCW EnInhibitCCW</b>	Enables the hardware over travel limits

## 7.5 REVERSING MOTION DIRECTION

In order to reverse the motion direction of the drive, the command to the drive needs to be reversed. In addition, the emulated encoder output polarity needs to be reversed if an external controller is using the emulated encoder outputs for feedback.

To reverse the command to the drive in Torque or Velocity Modes either change the wiring or change the parameters:

CmdSrc Setting	Wiring Method	Parameter Method
Analog Command	Swap the analog command connections (J4-24 and J4-25)	Change the sign of <b>CmdGain</b>
Command Variable	None	Change the sign of <b>Command</b>
PWM Input	Swap the PWM connections (J4-10 and J4-11)	Change the sign of <b>CmdGain</b>

To reverse the command to the drive in Position Modes:

PosCmdSrc Setting	Wiring Method
<b>PosCmdSrc</b> = AQuadB	Reverse the Ch A input to the drive by swapping J4-19 and J4-20.
<b>PosCmdSrc</b> = Step-Dir	The Direction command, J4-5, to the drive needs to be inverted by the user's controller.

To reverse the **Emulated Encoder Outputs** from the drive:

- Reverse the Emulated Encoder Outputs if the external control loops use the emulated encoder outputs for feedback.
- Swap the CHA and CHA/ emulated encoder outputs (J4-19 and J4-20) going to the external controller.



## 8 ADVANCED CONFIGURATION

The S200 is shipped with a factory configuration that is designed to work with a Smart Feedback Device (SFD) equipped motor to implement an analog commanded Torque/Current block.

The +10 V input (factory configuration) yields a maximum clockwise torque/current.  
The -10 V input yields a maximum counter clockwise torque/current.

By adjusting the rotary switch (S1) to set the emulated quadrature encoder output, a completed setup of the drive is now ready for many applications.

To configure the drive as an analog velocity loop with medium velocity loop bandwidth/stiffness, adjust the DIP switch (S2) so that pin 1 is in the up position.

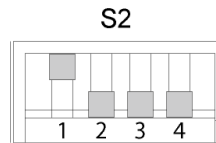

If this functionality serves the application need, the factory setup can be used as is in an application.

For applications other than the two standard configurations described above, such as using a PWM digital line for the command or implementing a position loop with Step and Direction command, the drive configuration will have to be customized through the Windows® PC compatible setup software called, S200Tools.

The rest of this chapter describes the S200 configuration options through diagrams of the control loops, reference lists of setup parameters with their definitions and range, and further explanations of drive capabilities.

# 8.1 BASE DRIVE TORQUE/VELOCITY CONTROL BLOCK DIAGRAM

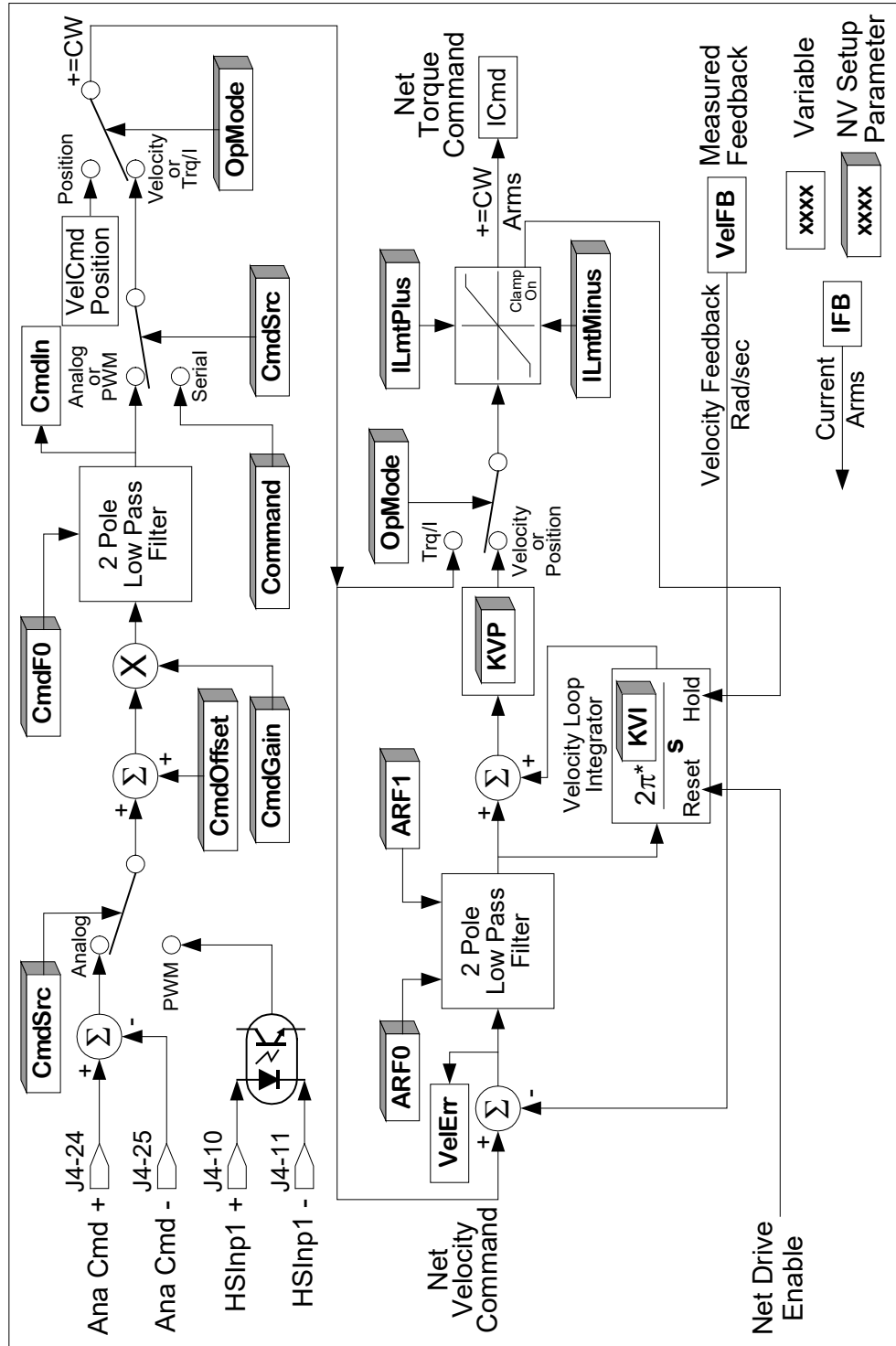

## 8.2 BASE DRIVE POSITION CONTROL BLOCK DIAGRAM

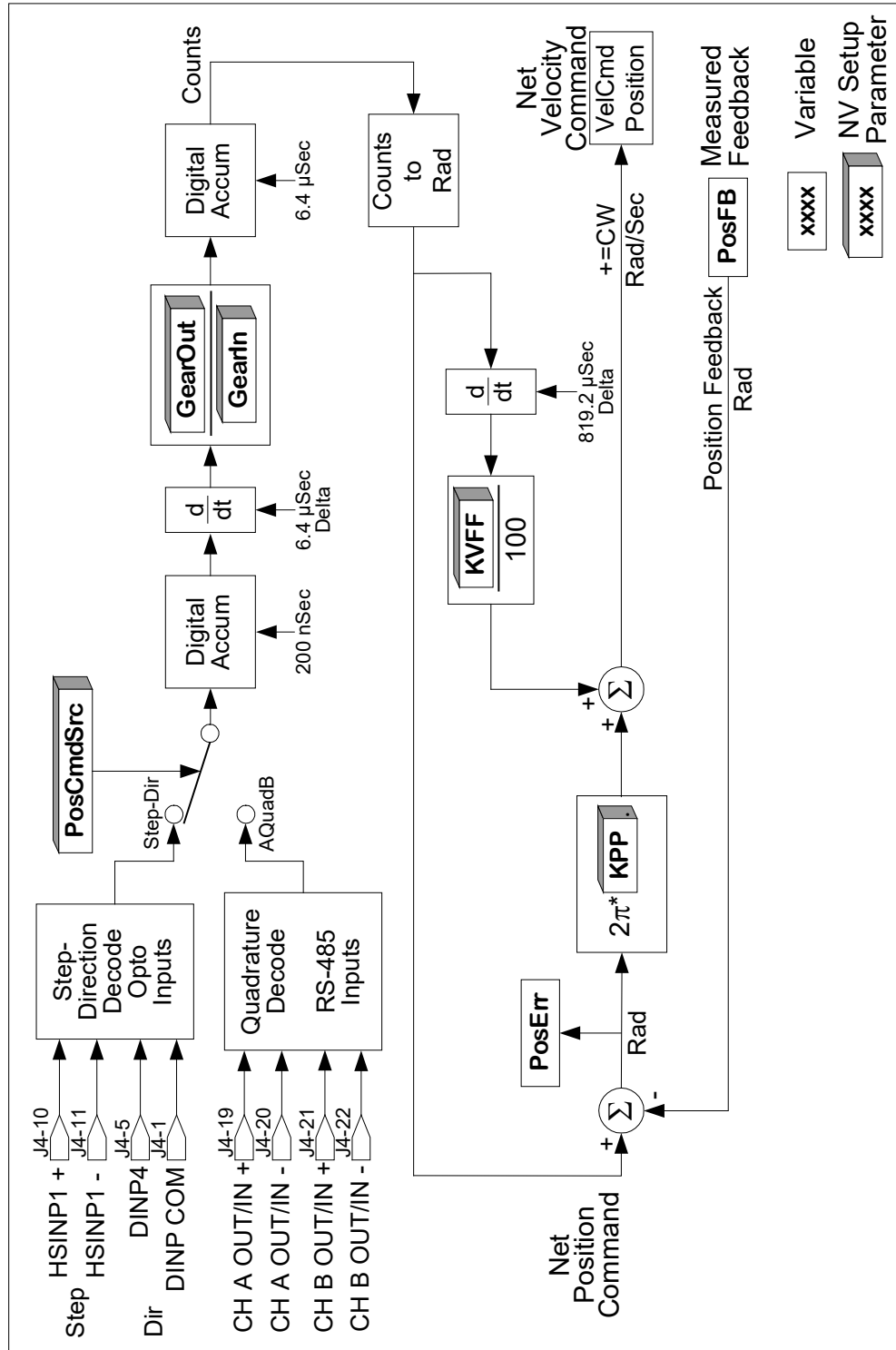

### 8.3 SYNQNET DRIVE TORQUE CONTROL BLOCK DIAGRAM

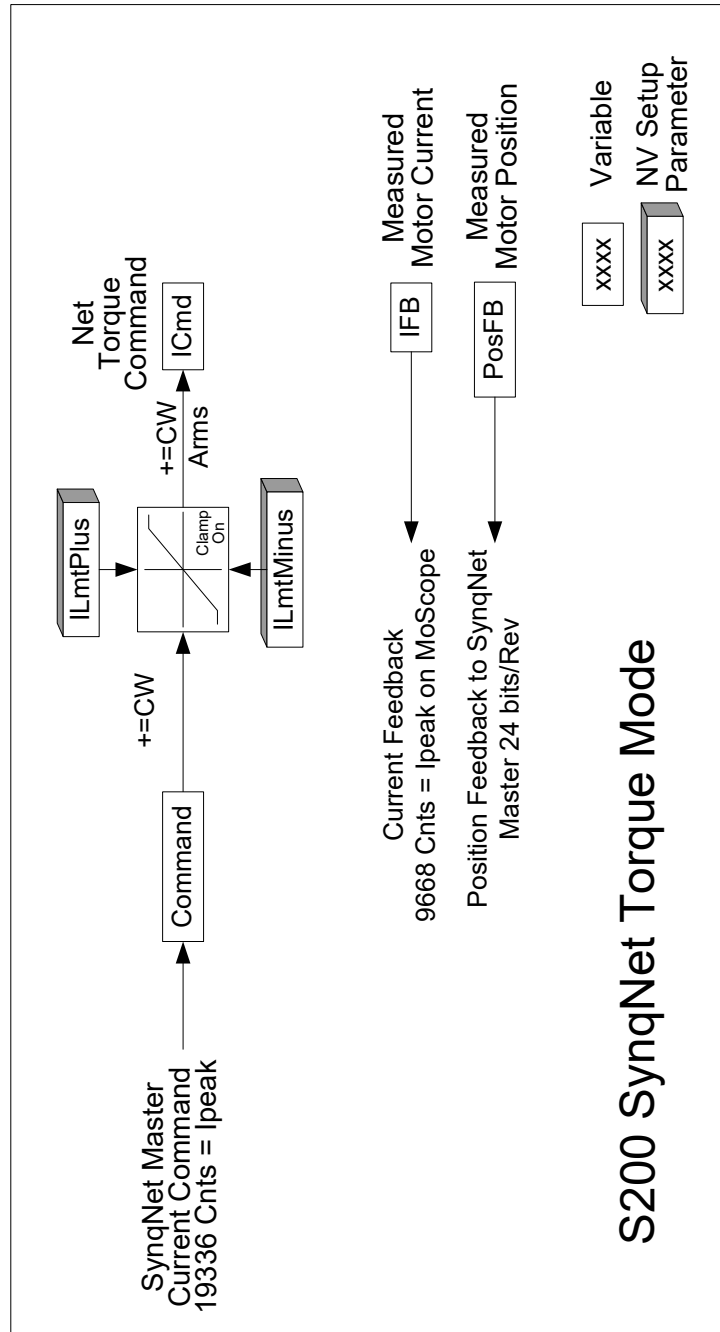

# 8.4 SYNQNET DRIVE VELOCITY CONTROL BLOCK DIAGRAM

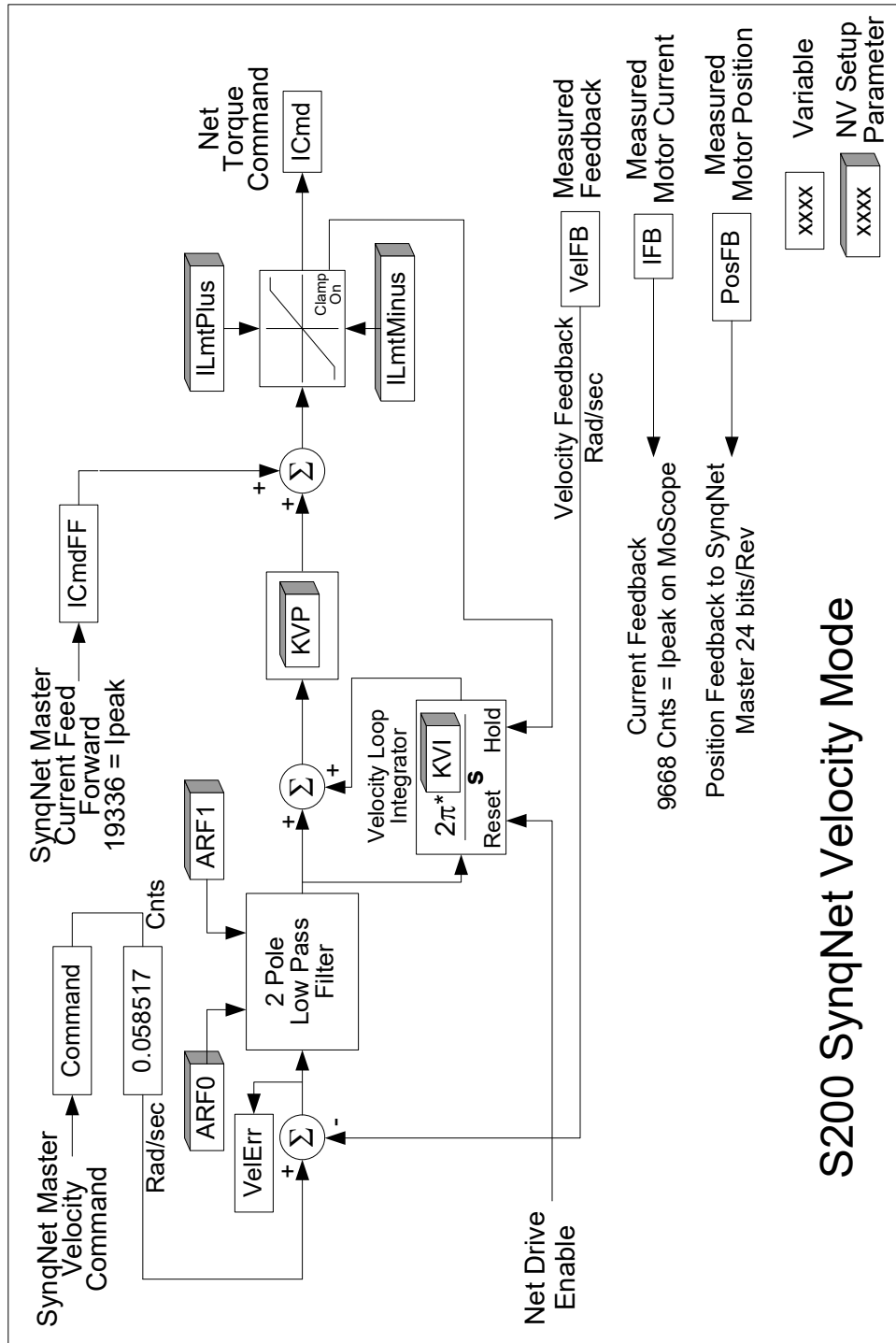

S200 SynqNet Velocity Mode

## 8.5 PARAMETERS AND VARIABLES

Setup parameter values control the operation and configuration of an S200 and read only variables give status information about the present operation of the drive. The below defines the three types of parameters and variables.

- **NV Parameter:** A type of variable stored in the non-volatile (NV) permanent memory on the drive. See NV Parameters for a complete list and descriptions.
- **Status Variable:** Gives information about the present state of the drive. Most of these variables are Read-Only, meaning that you cannot directly change them; their value is controlled by the drive itself, for example, measured shaft speed. See Status and Control Variables for a complete list and descriptions.
- **Control Variable:** A variable that controls a particular function on the drive. Control Variables are volatile (erased when power is removed) and are initialized at fixed default values every time that the drive is turned on. See Status and Control Variables for a complete list and descriptions.

The next section gives more details on the memory structure of the drive and how values are initialized. The succeeding two sections give detailed lists and descriptions of NV Parameters and Status, Control Variables respectively. The functionality of the drive may be updated from time to time, which may add to these lists.

### 8.5.1 Parameter and Variable Storage

The S200 has two types of memory: non-volatile memory and RAM. S200 non-volatile memory (NV memory) is similar to disk memory in a personal computer in that it can be written to and read from and maintains its settings without power. The S200 memory RAM is temporary memory. When control power is applied, all NV parameter values are automatically copied from NV memory into S200 RAM memory. The S200 operates out of temporary memory; that is the temporary memory parameter values set the S200 configuration and adjustments.

S200 Tools configuration software changes S200 settings, which include both parameters and variables. In the Offline branches of S200Tools configuration software, changes made to a setting are made only in the PC S200Tools memory on the PC. Clicking the **Download Drive** button sends the values to the drive's temporary memory. Clicking the **Download NV** button sends the values to the drive's NV permanent memory. In the latter case the drive's control power must be cycled to get the drive to load the values into active use. When downloading or uploading to the S200 from S200Tools software, all drive settings are copied. It is not possible to upload or download only one parameter or variable.

In the online branch of S200Tools, the **Drive Setup** screen of S200Tools operates differently than in offline. Under the Drive Setup screen, any change to a parameter is automatically communicated to the drive's temporary memory. Once all the parameters are set you should use the File menu to do a file save on the PC to save the drive configuration (\*.S2C). If a drive is connected, you can click the **Download Drive** or the **Download NV** buttons to send the parameter set into the drive.

In the online section of S200Tools the **Status** screen allows a custom selection of NV Parameters and variables to be selected. This screen is useful for interactively making setup changes and to view drive status. When changes are made to an NV Parameter or a Variable in this screen, the value in the S200 Tools PC memory is automatically copied to the S200 RAM memory for that particular parameter. Clicking **NV Save** on the Status screen uploads the current state of the drive temporary RAM and downloads all these settings to the S200 non-volatile memory. This step should be done before power cycling the drive control power and losing the drive setup changes.

## 8.5.2 Model Dependent Scale Factors

The Model Dependent Scale Factors are used to calculate limits for some of the drive parameters. The following table lists the model dependent scale factors.

<b>Model Dependent Scale Factors</b>			
<b>Model User</b>	<b>DIpeak ARMS</b>	<b>VBusScale Relative x</b>	<b>Description</b>
S20260	4.5	1	240 VAC 4.5 ARMS peak
S20360	9	1	240 VAC 9 ARMS peak
S20660	18	1	240 VAC 18 ARMS peak
S20330	9	0.25	90 VDC 9 ARMS peak
S20630	18	0.25	90 VDC 18 ARMS peak

## 8.5.3 Read/Write NV Parameters

**ARF0** 1.518 – 96382 Hz

**ARF1** 1.518 – 96382 Hz

ARF0 and ARF1 set the break frequency in Hz for the two single-pole anti-resonance low pass filters in the forward path of the velocity loop. They are used to help accommodate mechanical resonance in the system introduced by the load connected to the motor. See the Base Drive Torque/Velocity Control Block Diagram for more information.

**AuxFBDivisor** 1 to 2,147,483,647

(Option Card Only)

Supported over SynqNet.

This parameter is the divisor used to scale the raw incremental encoder counts or the Sin-Cos encoder interpolated counts from the Aux Feedback interface to the Aux position word. If the Aux Feedback device is used only for controller feedback then this parameter may be set to any value convenient for the application. If the Aux Feedback device is used to commutate the motor then it must be set to a specific value. For rotary motor commutation, this scaling converts the Aux Feedback position word to a word with 24 bits per revolution. For linear motor commutation, it converts to 24 bits per motor magnetic pole pitch distance. The table below lists a number of commonly desired settings for AuxFBDivisor.

Incremental (A quad B) encoder	
No motor commutation, 1 encoder quadrature count = 1 Aux Feedback count:	AuxFBDivisor = $2^{24} = 16,777,216$
Commutating a rotary motor or 24 bits per revolution:	AuxFBDivisor = number of quadrature counts per mechanical revolution
Commutating a linear motor or 24 bits per magnetic pole pitch:	AuxFBDivisor = number of quadrature counts per magnetic pole pitch

1 Vp-p Sin-Cos	
No motor commutation, 1 interpolation lsb = 1 Aux Feedback count or 65536 counts/Sin-Cos cycle:	AuxFBDivisor = $2^8 = 256$
Commutating a rotary motor or 24 bits per revolution:	AuxFBDivisor = number of Sin-Cos cycles per mechanical revolution
Commutating a linear motor or 24 bits per magnetic pole pitch:	AuxFBDivisor = number of Sin-Cos cycles per magnetic pole pitch

**AuxFBType** Type

(Option Card Only)

Supported over SynqNet.

This parameter selects the type of feedback wired to the AuxFB connector. It is a combination of the following single bit parameters:

AFBHalIDis, AFBDivisorSrc, AFBEnDatEnb, and AFBFBSrc.

The following table defines the state of these parameters for each supported feedback device.

Type	AFBHalIDis	AFBEnDatEnb	AFBDivisorSrc	AFBFBSrc
Incremental A Quad B	Disable	Disable	AuxFBDivisor	AQB
Incremental A Quad B with Halls	Enable	Disable	AuxFBDivisor	AQB
1 Vp-p Sin-Cos Incremental	Disable	Disable	AuxFBDivisor	SCD
1 Vp-p Sin-Cos Inc. with Halls	Enable	Disable	AuxFBDivisor	SCD



EnDat 2.1	Disable	Enable	AuxPPR	SCD
EnDat 2.1 Linear	Disable	Enable	AuxFBDivisor	SCD

See AuxFBDivisor to complete the setup of the Aux Feedback interface.

Note: Many EnDat 2.2 devices can be wired to the J14 AuxFB Connector as long as the 1 Vp-p Sin-Cos analog signals are also wired and the device will run in EnDat 2.1 compatibility mode. Power up initialization of absolute position will work.

#### **BatFDis**    **Enable/Disable**

This parameter enables or disables the Battery Low fault. The Battery input on the command I/O connector is an optional feature and is not required for proper operation of the drive. It is only required if the battery backup of the multi-turn information is required from the SFD. If the feedback device is not an SFD, then the battery does nothing.

0 - Enable Battery Fault

1 - Disable Battery Fault

#### **CmdF0**    **1.518 – 93254 Hz**

CmdF0 sets the break frequency in Hz for two cascaded single pole low pass filters on the hardware command input. There are two ranges of values for CmdF0; from 2915 to 24873 Hz cannot be set. The lower range is the active range suggested for velocity control and the upper range is used to effectively turn the filter off for velocity control or for use with torque/current control. This parameter is particularly useful when CmdSrc selects the PWM input for the command source. CmdF0 should be less than the input PWM frequency divided by 10 and preferably divided by 50 or more. See the Base Drive Torque/Velocity Control Block Diagram for more information.

#### **CmdGain**    **See Chart**

CmdGain sets the scale factor from the user input on the Command I/O connector (J4) to the internal servo loop command. CmdGain can be negative or positive, which allows the direction polarity to be changed. Because the input to the command processing block can be an analog voltage or a digital duty cycle and the servo loop could be Torque/Current or velocity there are four combinations of units listed below. See CmdSrc and OpMode for these settings. See CmdOffset for adding an offset to the command.

Expressed as an equation:

$$\text{CmdIn} = [(\text{User Input}) - \text{CmdOffset}] * \text{CmdGain}$$

**NOTE:** The Range of CmdGain is clipped by the value of CmdOffset. The chart below gives CmdGain units and numerical range assuming that CmdOffset is 0 V/50%.

CmdSrc	OpMode	CmdGain Units	+/- CmdGain Range
Analog	Torque / Current	ARMS / V	ARMS / V
Analog	Velocity	krpm / V	krpm / V
PWM	Torque / Current	ARMS / %	ARMS / %
PWM	Velocity	krpm / %	krpm / %

#### **CmdInNullEnb**    **Enable/Disable**

CmdInNullEnb enables or disables the Command In ADC Null function. CmdInNullEnb enabled allows the user to null the base drive CmdIn ADC by asserting DInp4 for a minimum of one second. The CmdInNull function will update the variable CmdOffset to null out the DC offset that is present and the CmdIn ADC at the time DInp4 is asserted. This function updates the drive NV memory copy of CmdOffset as well.

0 - Enable CmdIn ADC Null function

1 - Disable CmdIn ADC Null function (default setting)

#### **CmdOffset**    **Volts or Percent**

CmdOffset is added to the user input on the Command I/O connector J4 to allow any constant offset present in the source to be cancelled. Because the input to the command processing block can be an analog voltage or a digital duty cycle, there are two possible units. See CmdSrc for this setting and CmdGain for scaling the gain of the input command.

Expressed as an equation:

$$\text{CmdIn} = [(\text{User Input}) - \text{CmdOffset}] * \text{CmdGain}$$

**NOTE:** The range and resolution of CmdOffset is affected by the value of CmdGain. Its range covers the entire range of CmdIn.

**CmdSrc**    **Analog, PWM CMD, or Command Variable**

CmdSrc selects the source of the command. It selects between using the command I/O connector analog input or PWM CMD digital input or the serial command parameter.

- 00 - Analog input sets command (default).
- 01 - PWM input sets command.
- 10 - Software Command Variable sets command (analog input Cmd proc).
- 11 - Software Command Variable sets command (PWMCMD input Cmd proc).

**Command**    **± DIpeak or ± 18,310 rpm**

**Not supported over SynqNet.**

Sets the value of the command when CmdSrc is set to Command variable as opposed to the standard Analog or PWM CMD digital hardware inputs. The parameter units depend on whether the drive is in current or velocity control mode. **When OpMode is set to Position, this variable is not used.**

**CommMode**    **SetupS2-2, SFD, 6-Step, Brush**

Selects the commutation mode of the drive. The following table describes the different values for this parameter.

Mode	Description
SetupS2-2	DIP switch S2 position 2 selects between 6-step and SFD commutation, feedback.
SFD	Forces the drive to use SFD for feedback.
6-Step	Forces the drive to use 6-step.
Brush	Forces 6-step commutation with CU, CV, CW = 1 1 0.

**CommOff**    **± 180 Degrees**

Offsets the origin for the electrical commutation angle in degrees. Normally set to zero. Non-zero allows matching non-standard motors or systems.



***In 6-step mode, this parameter must be set to 0 for proper operation. See also CommMode.***

**Dinp1Pol**    **Invert or Normal**

This parameter selects the polarity of the Dinp1. When this parameter is set, the input to the FPGA is inverted before it is used by the logic. This parameter affects the sense of the enable I/O input. The following describes the different values for this parameter.

- 0 - Normal
- 1 - Invert

**Dinp2Pol**    **Invert or Normal**

This parameter selects the polarity of the Dinp2. When this parameter is set, the input to the FPGA is inverted before it is used by the logic. This parameter affects the sense of the InhibitCW I/O input. The following describes the different values for this parameter.

- 0 - Normal
- 1 - Invert

**Dinp3Pol**    **Invert or Normal**

This parameter selects the polarity of the Dinp3. When this parameter is set, the input to

the FPGA is inverted before it is used by the logic. This parameter affects the sense of the InhibitCCW I/O input. The following describes the different values for this parameter.

- 0 - Normal
- 1 - Invert

#### Dinp4Pol Invert or Normal

This parameter selects the polarity of the Dinp4. When this parameter is set, the input to the FPGA is inverted before it is used by the logic. This parameter affects the sense of the MSInp1 I/O input. The following describes the different values for this parameter.

- 0 - Normal
- 1 - Invert

#### DM1Map/DM2Map See Chart

Selects the variable sent to **DACMon1**, **DACMon2** analog output pins on Command I/O connector J4. The **DACMon1/2** output pins have a  $\pm 2.0$  V range centered around a 2.5 V bias, that is the output varies from 0.5 to 4.5 V and is 2.5 V when the selected DAC signal is zero.



**These DAC outputs are not clamped at maximum analog range. When the signal reaches maximum analog output, further signal increases cause it to wrap around to the opposite range extreme.**

#### DM1Map:

Parameter Value	Definition
VelErr 286 rpm/V	Velocity error.
PosFB 0.25 rev/V	Position big bits.
IdFB 0.8474 * DIpeak ARMS /V	Non-torque current.
VelFB 2288 rpm/V	Velocity little bits.
VelFB 9155 rpm/V	Velocity big bits.
PosErr 0.0625 Rev/V	Position loop position error.
VdCmd 134.5 * VBusScale/V	Quadrature voltage command.
PosFB 244.1e-6 rev/V	Position little bits.

#### DM2Map:

Parameter Value Velocity mode	Parameter Value Torque mode	Definition
VBus 380 * VBusScale V/V	-	Bus voltage.
CmdIn 9155 rpm/V	CmdIn 0.8474 * DIpeak/V	Command.
IFB 0.8474 * DIpeak/V	-	Torque current.
VelFB 1144 rpm/V	-	Velocity.
I2TFilt0.7152* (DIpeak <sup>2</sup> ) A <sup>2</sup> /V	-	I*I*t filtered value.
VU 812 * VBusScale /V	-	U phase l-n voltage command.
VqCmd 134.5 * VbusScale /V	-	Torque voltage command.
ICMD 0.8474 * DIpeak ARMS /V	-	Torque Current command.

Model Dependent Scale Factors			
Model User	DIpeak ARMS	VBusScale Relative x	Description
S20250	4.5	1	240 VAC 4.5 ARMS peak

S20260	4.5	1	240 VAC 4.5 ARMS peak
S20330	9	0.25	90 VDC 9 ARMS peak
S20350	9	1	240 VAC 9 ARMS peak
S20360	9	1	240 VAC 9 ARMS peak
S20630	18	0.25	90 VDC 18 ARMS peak

**DPoles 0 – 62 Poles (even numbers only)**

DPoles sets the drive for the appropriate motor pole count. Typically set to match the motor pole count. With a feedback device that has multiple cycles per revolution, DPoles is set to twice the ratio of motor electrical cycles to feedback device electrical cycles per revolution. Setting DPoles to zero turns electronic commutation off.

Binary 0 = 0 Poles

Binary 1 = 2 Poles

...

Binary 31 = 62 Poles



***When the DPoles setting does not match the actual motor pole count, the motor's operation will be erratic and could be dangerous.***

**EncOut 125 to 32768 Lines Via Rotary Switch S1, See Chart**

Supported over SynqNet.

Sets the J4-17 to J4-22 emulated encoder output signal's line count (pulses per revolution) when the EMU setup rotary switch S1 on the base drive is set to position 0. All other settings for rotary switch S1 have fixed line counts. (EncOut \* 4) = the number of quadrature counts per revolution.

EncOut	Line Count	EncOut	Line Count
0	500	8	8192
1	512	9	10000
2	1000	10	125
3	1024	11	128
4	2000	12	16384
5	2048	13	20000
6	4096	14	Programmable by EncOutPPR Default = 32768
7	5000	15	2500

**EncOutPPR 0 to 65535 Lines**

Supported over SynqNet.

Sets an arbitrary emulated encoder output line count, also know as pulses per revolution, for J4-17 to J4-22 outputs. EncOutPPR is only used if the EMU setup switch S1 on the base drive is set to position 0 and the EncOut NV parameter is set to Programmable.

Note that if EncOutPPR is set to 0 with EncOut set to programmable the J4-17,18 Z-pulse can be turned off. A SynqNet master application program can then switch EncOut from 14 to an appropriate other value to enable and disable the Z CH output at the right point in a machine cycle to be used to trigger an action like a camera. EncOutZOffset can be used to position the Z CH OUT pulse at the exact desired position.

**EncOutZOffset 0 to 65535 Counts**

Supported over SynqNet.

EncOutZOffset sets the location of the emulated encoder marker or Z-pulse on the J4-17,18 CH Z OUT. Base unit (PosFB – EncOutZOffset) is sent to the decoding logic to

make the CH Z OUT so EncOutZOffset allows electronically setting the exact mechanical location for the emulated Z pulse. See diagram for exact phase of the Z-pulse.

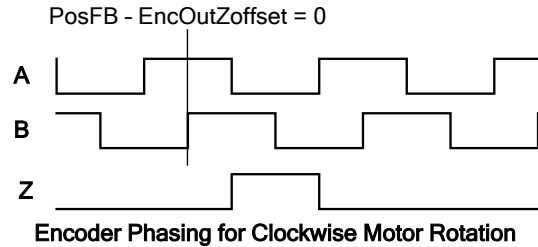

#### **EnInhibitCCW On or Off**

**Not supported over SynqNet.**

Enables or disables the hardware input that prevents motion in the counter clockwise direction. When enabled and the hardware input is active, current/torque operation clamps the current command to 0 or positive/clockwise. With a velocity loop, function enabled, and the hardware input active, the velocity command is clamped to 0 or positive/clockwise. When both InhibitCCW and InhibitCW are enabled and both hardware inputs are active, the motion command is clamped to 0.

- 0 - OFF
- 1 - ON

#### **EnInhibitCW On or Off**

**Not supported over SynqNet.**

Enables or disables the hardware input that prevents motion in the clockwise direction. When enabled and the hardware input is active, current/torque operation clamps the current command to be 0 or negative/counter clockwise. With a velocity loop, function enabled, and the hardware input active the velocity command is clamped to be 0 or negative/counter clockwise. When both InhibitCCW and InhibitCW are enabled and both hardware inputs are active, the motion command is clamped to 0.

- 0 - OFF
- 1 - ON

#### **FBSrc Base Unit Feedback, Option Card Feedback**

**(Option Card Only)**

**Supported over SynqNet.**

Enables When this bit is set to the Option Card Feedback position, it disables both the SFD and Hall feedback faults and device interfaces on the base unit. This bit also forces the feedback position word from the SFD to be zero. The drive is set for sine commutation. In this mode, writing to the CommOff parameter will change the motor position. This mode is used when an Option card is attached and the primary feedback device is a Comcoder.

- 0 - Base Unit feedback device connected.
- 1 - Option card feedback device connected.

#### **FltDiag Off or Diagnostic Blink Code**

FltDiag selects between the DOUT1 (Fault) line being static low for no fault and static high for drive off and/or faulted, to low for no fault and toggle high low N number of times with the diagnostic LED fault blink code. The DOUT1 line output is still static high for drive off. See FaultCode entry for a chart giving the blink counts for each fault.

- 0 - OFF (default)
- 1 - Diagnostic Blink Code

#### **FltRstMode Edge or Level**

FltRstMode selects how faults are reset by the hardware enable input DInp1 on J4-2. When set to Level, faults are reset when the drive is in the hardware disabled state. When set to Edge, faults are reset when DInp1 hardware enable transitions from disabled to enabled.

- 0 - Edge - Reset faults on DInp1 disabled to enabled transition.
- 1 - Level - Reset faults on hardware disabled state. (Default)

#### **GearIn 0 - 65535**

**Not supported over SynqNet.**

GearIn is used to scale the input position command when configured as a position

controller (OpMode = Position). This parameter is the divisor used to calculate the revs per step for the position mode. The formula for calculating motor shaft revs per input count is:

$$[\text{GearOut}/\text{GearIn}]/256 = \text{revs per input count}$$

There is 1 input count per step input or per input quadrature count depending on the position command source selected by PosCmdSrc.

**See Also:** GearOut and OpMode.

**GearOut**    -32768 – +32767

**Not supported over SynqNet.**

GearOut is used to scale the input position command when configured as a position controller (OpMode = Position). This parameter is the dividend used to calculate the revs per step for the position mode. Typically, this parameter is 256, which allows GearIn to be numerically equal to the number of steps per rev. GearOut negative reverses the direction of motion for a given command. The formula for calculating motor shaft revs per input step is:

$$[\text{GearOut}/\text{GearIn}]/256 = \text{revs per input step}$$

There is 1 input count per step input or per input quadrature count depending on the position command source selected by PosCmdSrc.

**See Also:** GearIn and OpMode.

**HSInp1Pol**    Invert or Normal

This parameter selects the polarity of the HSInp1. When this parameter is set, the input to the FPGA is inverted before it is used by the logic. This parameter affects the sense of the HSInp1 I/O input.

0 - Normal

1 - Invert

**I2TF0**    23.16e-6 – 1.470 Hz

I2T0 sets the break frequency in Hz for the I2T filter used to protect the motor coils from transient thermal overload caused by very high peak currents compared to the motor's continuous current capability. I2Tf0 should be set based on the motor coil's thermal time constant. However, typical motor data sheets only give the thermal time constant for the entire motor (coil+back iron+housing) and no data for the coil's time constant. Since the coil thermal time constant is much faster than the entire motor time constant I2Tf0 is typically set to between 4 and 10 times faster than the motor's bulk thermal time constant published in the data sheet. Given a desired time constant, set the I2TF0 value to:

$$I2TF0 = 1/[(2\pi) * (\text{Motor Thermal Time Constant in sec})]$$

**I2TTrip**    0 to 1.19 DIpeak

I2TTrip sets the fault trip level for the I2T fault used to protect the motor coils from transient thermal overload caused by very high peak currents compared to the motor's continuous current capability. It is typically set equal to the motor data sheet continuous current capability when the motor has no internal thermal shut down sensor. When the motor includes a thermal sensor I2TTrip is typically set 1.25 times larger than the motor's continuous current capability with the motor's internal thermal sensor providing protection against small overloads.

**ILmtPlus/ILmtMinus**    % of DIpeak

ILmtPlus and ILmtMinus are the clockwise and counter-clockwise current limits, respectively. They set the maximum allowable torque command in their respective directions. They are a percentage of the drive's peak current rating DIpeak.

**ITMode**    Fault/Foldback

Selects whether the drive faults on too much peak current for too long, i.e., excessive I\*t, or folds the current limits back by clamping them to 67% (IFldBack) or less. If ILmtPlus and ILmtMinus are set to 67% or less, fold back has no effect. See FoldBack for related information.

**KIP**    79.226\*VBusScale/DIpeak to 19014\*VbusScale / DIpeak V / A

KIP sets the proportional gain of the current loops. The bandwidth of the current loop in Hz is = KIP/(Motor I-L)/(2π). See the drive specification section for recommended bandwidths.

**KPP 0.379 – 93.99 Hz****Not supported over SynqNet.**

Sets KPP sets the proportional gain of the position loop in Hz. When OpMode = Position the net velocity command (VelCmd) in rad/sec is:

$$\text{VelCmd} = \text{KPP} * (2\pi) * (\text{PosErr}) + \text{KVFF} / 100 * d/dt(\text{PosCmd})$$

**KVFF 0 – 199 %**

Sets the feed forward gain from the derivative of the position command directly to the velocity command of the velocity loop and has the units of percent. When OpMode = Position the net velocity command (VelCmd) in rad/sec is:

$$\text{VelCmd} = \text{KPP} * (2\pi) * (\text{PosErr}) + \text{KVFF} / 100 * d/dt(\text{PosCmd})$$

**KVI 0, 0.0238 – 753.9 Hz**

KVI adjusts the velocity loop integral compensation. It sets the break out frequency between predominantly integral compensation and predominantly proportional compensation. Higher KVI values give higher integral gain and shorter time constants. A value of below 0.19 Hz turns off KVI. There is no integral compensation only proportional from KVP. See the Base Drive Torque/Velocity Control Block Diagram for more information.

**KVP 221.0e-6\*DIpeak to 25.09\*DIpeak ARMS/rad/sec**

KVP sets the proportional gain of the velocity loop and has the units of ARMS/rad/sec. The idealized velocity loop bandwidth in Hz is  $\text{KVP} * \text{KT} / \text{JTOT} / (2\pi)$  where KT is the motor's torque constant, JTOT is the total shaft inertia and the units of KT/JTOT should come out to rad/sec<sup>2</sup>/ARMS. See the Base Drive Torque/Velocity Control Block Diagram for more information.

**OpMode Current, Velocity, SetupS2-1, Position****Not supported over SynqNet.**

OpMode selects between current/torque, velocity, and position control modes or whether the SETUP1 hardware switch is used for selecting between current/torque or velocity operating mode.

OpMode	Description
000	Torque/Current Mode
001	Velocity Mode (default)
010	Setup DIP switch S2 position 1 (SetupS2-1 = 0 = Velocity).
011	Position Mode

**Note:** With SynqNet OpMode is written to by the SynqNet master over the network each network update period. All SynqNet master versions that support the S200 can work in Torque/Current mode. Newer SynqNet master versions can optionally be set to run the drive in Velocity Mode.

**PosCmdSrc Step-Dir, AQuadB****Not supported over SynqNet.**

PosCmdSrc selects the source of the position command. It selects between using Command I/O connector J4 optically isolated inputs for Step-Dir and the emulated encoder port used as an A quad B differential input. J4-10,11 and J4-5 for Step-Dir and J4-19,20 and J4-21,22 for A quad B inputs. See the Base Drive Torque/Velocity Control Block Diagram for more information.

0 - AQuadB

1 - Step-Dir (default)

**PosErrorMax 0 to 255.996 Rev****Not supported over SynqNet.**

PosErrorMax sets the following error limit. When

$$|(\text{commanded position}) - (\text{PosFB})| > \text{PosErrorMax}$$

The drive will fault with a following error fault. The following error fault, and thus PosErrorMax, are only active when OpMode is Position. Default value is maximum value.

**SelSFDParm SFD or Drive**

Determines whether the SFD motor parameters or drive setup values are used for the following parameters:

<b>KVP</b>	Velocity loop proportional gain.
<b>KIP</b>	Current loop proportional gain.
<b>DPoles</b>	Drive poles.
<b>I2TF0</b>	Response speed for motor transient thermal protection.
<b>I2TTrip</b>	Fault trip level for motor transient thermal protection.
<b>ILmtPlus</b>	Sets the drive maximum lout based on motor I <sub>PEAK</sub> .
<b>ILmtMinus</b>	Sets the drive maximum lout based on motor I <sub>PEAK</sub> .

**SFDSpan Span or No Span**

Sets how the drive handles single sample communication errors with the SFD. Span interpolates SFD feedback position for isolated single sample communications errors. No Span faults the drive on any SFD communication error. Recommended (default) setting is Span.

- 0 - No Span
- 1 - Span

**SWClrFault Not Clear or Clear**

This parameter will clear the fault logic.

- 0 - Not Clear (default)
- 1 - Clear



## 8.5.4 Status And Control Variables

**AuxFBComAng** +180° to -180° (Option Card Only)  
Supported over SynqNet.

This register is the value of the commutation position from the AFB interface. It is used to generate the commutation angle in the drive.

**AuxFBEnDatFlt** Fault, No Fault (Option Card Only)  
Supported over SynqNet.

This bit indicates that the Aux Feedback interface encountered an error when trying to read data from an EnDat device. Sources of error are:

- 1 - EnDat device recover timeout from last transaction.
- 2 - EnDat device calculation timeout.
- 3 - EnDat CRC fault.

**AuxFBHallFlt** Fault, No Fault (Option Card Only)  
Supported over SynqNet.

This bit indicates the AuxFB Halls are in an illegal state of either all ones or zeros.

- 0 - No Fault
- 1 - Fault

**AuxFBPTCFlt** Fault, No Fault (Option Card Only)  
Supported over SynqNet.

This bit indicates the AuxFB PTC has generated a fault.

- 0 - No Fault
- 1 - Fault

**AuxFBSCDFlt** Fault, No Fault (Option Card Only)  
Supported over SynqNet.

This bit indicates that the amplitude of the sum of the sine and cosine signals is not within +/-30% of the nominal 1.0 Vp-p.

- 0 - No Fault, amplitude in range.
- 1 - Fault, amplitude not within ±30%.

**CmdIn** (-Dipeak to +Dipeak) or (-18,310 to +18,310 rpm)

CmdIn is the value of the output of the command processing block. This variable's units depend on whether the drive is in current or velocity control mode. See OpMode for control mode information.

**DInp1** Inactive, Active

Indicates the state of the drive's enable input on the Command I/O connector (J4).

- 0 - Active state, current flows in opto isolator input diode.
- 1 - Inactive state, no current flow.

**DInp2** Inactive, Active

For SynqNet, see mpiMotorGeneralln.

Indicates the state of the hardware input DINP2 on the Command I/O connector (J4).

- 0 - Active state, current flows in opto isolator input diode.
- 1 - Inactive state, no current flow.

**DInp3** Inactive, Active

Indicates the state of the hardware input DINP3 on the Command I/O connector (J4).

- 0 - Active state, current flows in opto isolator input diode.
- 1 - Inactive state, no current flow.

**DInP4      Inactive, Active**

Indicates the state of the hardware input DInP4 on the Command I/O connector (J4). For OpMode = Position, PosCmdSrc = Step-Dir this input is the Direction input. In the inactive state, no LED current, with positive GearOut PosCmd increments with each Step input edge, i.e. the motor moves clockwise.

0 - Active state, current flows in opto isolator input diode.

1 - Inactive state, no current flow.

**DriveOK      Fault , No Fault**

Drive fault status indicator. This signal is actually the inverse of the FAULT/ DOUT1 output of the drive on the Command I/O connector (J4). Current flows through DOUT1 when DriveOK is active or logic one.

0 - Drive fault, see FaultCode.

1 - Drive not faulted.

**EMUAI      0, 1**

This variable indicates the state of the emulated encoder channel A pin on the Command I/O connector (J4).

0 - Input CH A OUT– more positive then CH A OUT+.

1 - Input CH A OUT+ more positive then CH A OUT–.

**EMUBI      0, 1**

This variable indicates the state of the emulated encoder channel B pin on the Command I/O connector (J4).

0 - Input CH B OUT– more positive then CH B OUT+.

1 - Input CH B OUT+ more positive then CH B OUT–.

**Enabled      Off, On**

This variable indicates the enable state of the drive power stage. This signal is the inverse of the active on RUN/DOUT2 output of the drive on the Command I/O connector (J4).

Current flows through DOUT2 when Enabled is active or logic one.

0 - Drive disabled power stage OFF.

1 - Drive enabled power stage ON.

**EnDatDistMT      0 to 65535**

Supported over SynqNet.

If an EnDat 2.1/2.2 encoder is present, this variable holds the number of distinguishable multi-turns a rotary encoder can resolve.

**EnDatPPR      0 to  $2^{32} - 1$** 

Supported over SynqNet.

If an EnDat 2.1/2.2 encoder is present, this variable holds the number of signal periods per revolution for a rotary encoder or signal period length in nm (0.001um) for linear encoders.

**ExtFaults      Status Value**

This variable gives the extended fault status of the drive. Each bit represents an individual fault that is logically OR-ed with other faults. Note that this variable remembers its last active value and can be used as a one deep fault log.

Code	Extended fault	Code	Extended fault
1	SFD UART parity error	9	Drive under temperature
2	SFD UART overrun error	10	Drive short circuit
3	SFD UART framing error	11	Drive output over current
4	SFD frame timeout	12	Option card read timeout
5	SFD transfer incomplete	13	Option card watchdog timeout
6	SFD CRC error(s)	14	Step size overflow
7	SFD Motor Data timeout	15	Position error overflow
8	Drive over temperature	16	AuxFB Fault

**FaultCode Status Value**

This variable gives the fault status of the drive. The below table lists the possible fault states and gives the number of blinks that the drive's front panel Status LED will blink to indicate the fault. See also ExtFaults for further specifics on a given fault.

Blink Count	Status	Blink Count	Status
1	Not Assigned	11	Hall Fault
2	Motor Over Temp	12	SFD Configuration Error
3	Drive Over/Under Temp	13	SFD Short
4	Drive I*t Too High	14	SFD Motor Data Error
5	Motor I*t Too High	15	SFD Sensor Failure
6	Optional Battery low	16	SFD UART Error
7	Bus Over Voltage	17	SFD Communication Error
8	Bus Under Voltage	18	Option card Watch Dog timeout
9	Motor I-l or I-n Short	19	Position error too large
10	Output Over Current	20	Open Card Fault

**FoldBack Normal, Foldback**

Indicates whether the drive is actively folding back the peak current limits because of excessive I\*t. ITMode can be set to fault the drive on either excessive I\*t or fold back.

0 - Not in fold back/Not asserting I\*t fault.

1 - Fold back/I\*t fault.

**HallInp 0-7 Decimal**

This variable reads back the state of the Hall inputs to the drive on the drive feedback connector.

Input Bit	Description
IN8	Hall A
IN9	Hall B
IN10	Hall C

Input CW	Input CU	Input CV	HallInp Value
1	1	1	7
1	0	1	6
1	1	0	5
1	0	0	4
0	1	1	3
0	0	1	2
0	1	0	1
0	0	0	0

**HSInp1 Inactive, Active**

Indicates the state of the hardware input HSInp+, HSInp- on the Command I/O connector (J4). For OpMode = Position, PosCmdSrc = Step-Dir this input is the Step input. Input transitions from LED current to no LED current yields a step count while input transitions from no LED current to LED current yields no action.

0 - Active state, current flows in opto isolator input diode.

1 - Inactive state, no current flow.

**HSOT -50° C to 137.6° C**

Read only variable HSOT is the temperature at which the drive will generate a Heat Sink over temperature fault. Comparing HSOT minus ambient temp to HSTemp minus ambient temp can give an indication of the amount of head room from thermal overload that the drive has during normal operation.

**HSTemp** -41.1° C to 125.8° C

HSTemp reads back the heat sink temperature. HSTemp determines how close the drive is to thermal shut down by comparing the temperature rise above ambient to the potential rise above ambient at the drive over temperature fault trip, which can be read as HSOT.

**IFB, IdFB** -DIpeak to +DIpeak

These variables read back the torque (IFB) and non-torque (IdFB) derated current values.

IFB - Motor torque current.

IdFB - Motor non-torque current.

**LogicVer** 0 - 15 Decimal

LogicVer gives the version number of the drive logic as a 4-bit unsigned integer. Versions are assigned sequentially and if necessary, the numbers wrap around (if there are more than 16 versions). Primarily indicates control logic hardware revisions. See variable VerLW for the control logic version.

**Model** 0 - 31 Decimal

**Model** is the base unit identity code for the drive. The only codes defined are in the chart below. Other codes are configuration errors.

Base Model	
S20260	240 VAC 4.5 ARMS
S20360	240 VAC 9 ARMS
S20660	240 VAC 18 ARMS
S21260	240 VAC 30 ARMS
S22460	240 VAC 48 ARMS
S20330	90 VDC 9 ARMS
S20630	90 VDC 18 ARMS

**MTemp** 0 - 864,870 Ohms

This variable reads back the motor temperature A/D value from the SFD. The value is read back as the thermal sensor resistance. Using the motor thermal sensor specification this value can then be converted to a winding temperature.

**PosFBMTrn** -2048 to +2047 Turns

This variable reads back an instantaneous sample of the shaft position multi-turn from the SFD feedback port (J3).

**PosFB** 0 to 65535.9961 Counts

This variable reads back an instantaneous sample of the shaft position within one rev. There are 24 bits within one rev, but the displayed value is scaled for 65536 counts per rev (i.e. bits 17 through 24 show up as a fractional count after the decimal point). See PosFBMtrn for integral revolutions.

**PWMLo** Base, Half Base

Indicates whether the drive has switched to half base PWM frequency. The drive switches to half base PWM frequency; when the measured motor current is above  $0.53 * DI_{peak}$  and the electrical commutation frequency is less than 2.9 Hz. The PWM frequency returns to base if the measured motor current reduces below  $0.32 * DI_{peak}$  or the drive speeds up beyond 4.77 Hz commutation electrical frequency.

0 - Drive uses base PWM frequency.

1 - Drive uses half base PWM frequency

**SetupS1** 0-9

This variable reads back the state of the rotary user setup switch S1 that determines the line count of the emulated encoder EMUA and EMUB outputs with SFD feedback or the current loop proportional gain KIP for 6-step feedback. See Configuring with SFD Feedback.

**SetupS2** 0-15 decimal

This variable reads back the state of the 4 position DIP setup switch S2 on the drive.

Switch position #1 is LSB.

Open (high)

Closed (low)

**SFDExtFaults Status Value**

This variable gives the detailed fault code of the SFD.

FaultCode	Status
000	No Fault
001	Sensor Error
010	No Fault
011	Multi-turn Fault
100	No Fault
101	No Fault
110	No Fault
111	No Fault

**SixStep SFD, 6-Step**

This variable indicates whether the drive is in 6-step or sinusoidal current control.

**SWEnable Disable, Enable**

Serial communications channel motor power enable. Both the hardware enable input on the command I/O connector and SWEnable must be active for power to flow to the motor. Base units have SWEnable active at power up. This variable is provided for convenience when working with a PC set utility.

0 - Disables drive.

1 - Enable set by state of hardware enable input (default).

**VBus 0 to 523 volts : AC Input Drives****0 to 131 volts : DC Input Drives**

This variable reads back an instantaneous sample of the voltage of the bus supplying power to the motor.

**VelFB -18,310 rpm to +18,310 rpm**

This variable reads back an instantaneous sample of the shaft velocity feedback. It has a resolution of 0.5588 rpm. When measuring speed, use Velocity for least noise and maximum accuracy.

**Velocity -18,310 rpm to +18,310 rpm**

This variable reads back a filtered version of the shaft velocity feedback. It has the same units as VelFB, but it is much more precise for careful measurements of shaft speed because the filtering greatly lowers noise. To implement the filtered velocity value the drive subtracts two consecutive PosFB values sampled at a 26.21 mSec sample period which corresponds to a 38.15 Hz sample rate. This filter is equivalent to adding 512 consecutive samples of VelFB and dividing by 512.

**VerLW 0.0a to 255.9z**

VerLW gives the version number of the drives logicware as three integer bytes.

This manual documents VerLW 3.0A and newer.

## 9 SYNQNET CONFIGURATION

For S200 Series drives that support SynqNet, the following sections explain proper drive configuration.

### 9.1 DRIVE FPGA TABLE

Node Type	Option	Valid FPGAs
0x00030030	0x00000000	0xC0FE0036

For more information about FPGAs, visit Motion Engineering, Inc.'s Technical Support site. (<http://support.motioneng.com>)

Go to Hardware -> Drives -> FPGA Images

Parameter	Specification
Node Type	0x00000000
Option	0x00000000
FPGA	0xC0FE0036
Motor Count	1
Drive Count	0
Secondary Encoder Count	1
SqNode Digital Out Count	0
SqNode Digital In Count	0
SqNode Analog Out Count	0
SqNode Analog In Count	0

Parameter	Motor0
Capture Count	1
Probe Count	1
Pulse Count	0
Dedicated In 0 – Amp Fault	1
Dedicated In 1 – Brake Applied	0
Dedicated In 2 – Home	1
Dedicated In 3 – Limit HW Pos	1
Dedicated In 4 – Limit HW Neg	1
Dedicated In 5 – Index Primary	1
Dedicated In 6 – Feedback Fault	1
Dedicated In 7 – Captured	0
Dedicated In 8 – Hall A	1
Dedicated In 9 – Hall B	1
Dedicated In 10 – Hall C	1
Dedicated In 11 – Amp Active	1
Dedicated In 12 – Index Secondary	1
Dedicated In 13 – Warning	1
Dedicated In 14 – Drive Status 9	1
Dedicated In 15 – Drive Status 10	0
Dedicated Out 0 – Amp Enable	1
Dedicated Out 0 – Brake Release	0

<b>Motor</b>	<b>General Purpose I/O Bit</b>	<b>Name</b>	<b>Valid Configurations</b>
0	0	RS422 IN 0	Input
0	1	RS422 IN 1	Input
0	2	RS422 IN 2	Input
0	3	RS422 IN 3	Input
0	4	RH 1	Input
0	5	RH 2	Input
0	6	RH 3	Input
0	7	PS OK	Input
0	8	IO SHORT	Input
0	9	DINP2	Input
0	10	DINP3	Input
0	11	DINP4	Input
0	12	HSINP1	Input

## 9.2 **DRIVE MONITOR**

### 9.2.1 Drive Monitor Table

```

/* kollmorgen_s200.h */

/*
 * Drive Monitor Table
 */

typedef enum {

    S200MonitorAddressCMD_IN = 0x3938, /* Value of the output of the command
processor block */
    S200MonitorAddressHS_TEMP = 0x8726, /* Heat sink temperature value */
    S200MonitorAddressIFB = 0x4544, /* Torque derotated current value */
    S200MonitorAddressIDFB = 0x4746, /* Non-torque derotated current value */
    S200MonitorAddressM_TEMP = 0x8700, /* Motor temperature A/D value frm the
SFD */
    S200MonitorAddressPOS_MTRN = 0x5756, /* Multi turn feedback data */
    S200MonitorAddressPOS_FB_LSBS = 0x2E2D, /* Lower 16 bits of the feedback */
    S200MonitorAddressPOS_FB_MSBS = 0x872F, /* Upper 8 bits of the feedback */
    S200MonitorAddressVBUS = 0x3736, /* Motor power voltage */
    S200MonitorAddressVEL_FB = 0x1D1C /* Shaft velocity feedback */
} S200MonitorAddress;

```

### 9.2.2 Monitoring Real-time Data from Drive

Some data from the drive is not part of the standard MEI I/O. However, it can be monitored in real-time from the drive. For more information on how to monitor real-time data from the drive, see Drive Monitor.

List of real-time monitor fields. This is a partial list of supported fields. Consult your drive manual for a complete list.

- CmdIn
- HSTemp
- IFB
- IdFb
- MTemp
- Pos\_MTrn (PosFbMTrn)
- PosFbLSBS (PosFb)
- PosFbMSBS (PosFb)
- VBus
- VelFB



## 9.3 ACCESSING DRIVE PARAMETERS OVER SYNQNET

### 9.3.1 Introduction

The drive's functionality is designed to use various drive parameters and instructions, which are communicated over SynqNet. Some parameters have read-only access, whereas other parameters may have read/write access. The parameters can be stored in non-volatile memory on the drive and are used on each power-up cycle.

Examples of **read-only drive parameters** are:

- drive command value (CMD\_IN)
- drive model number (MODEL)
- drive bus voltage (V\_BUS)

Examples of **read/write drive parameters** are:

- commutation offset value (COMM\_OFF)
- proportional gain of the current loop (KIP)
- motor pole count (D\_POLES)

Drives are shipped from the factory with motor parameters set to zero and application parameters set to their default values.

Parameters are identified by their **command string** and **index**. The index is used when accessing a parameter over SynqNet. Drive parameters are implemented for particular drive models and firmware versions.

**NOTE:** Supported parameters for a drive may be different, depending on the version of firmware.

The MPI library contains a general drive parameter interface that is able to handle any set of drive parameters, independent of the MPI library version. It uses a drive parameter map file to determine the valid drive parameters. Individual drive parameters can be set (or read) using MPI methods or with the sqDriveParam Utility. A list of drive parameters can also be set (or read) using MPI methods or with the sqDriveConfig Utility.

The following sections describe the syntax of utilities used when accessing parameters. These utilities are typically executed from a DOS window in the XMP\bin\WinNT directory.

### 9.3.2 Memory Operations on Drive Parameters

The drive firmware operates by using parameters stored in RAM. However, these parameters can also be saved in non-volatile memory (E2PROM), where they are loaded into RAM upon power up. The non-volatile memory can also be cleared. Parameters may be reset to their default values and a set of saved parameters may be loaded from the non-volatile memory into the RAM.

The operations described above are executed using SynqNet Direct Commands, which are listed in the table below. The command string is used to identify the specific command. It also indicates the syntax of the command used when communicating with the drive over the serial port.

SynqNet Direct Commands			
Description	Command String	SynqNet Direct Command	Notes
Save Parameters	SAVE	0x1C	Save all parameters to non-volatile memory.

### 9.3.3 Accessing Individual Parameters

Use the sqDriveParam Utility for accessing individual parameters. The syntax follows the conventions listed below.

- **x** is the node number. Nodes are numbered starting from zero.
- **y** is the drive, or axis, number on that node. Drives are numbered starting from zero.
- **<parameter index>** identifies the parameter being accessed.
- **<data value>** is the data being written to the parameter.

Syntax for reading drive parameters:

```
sqdriveparam -server <ip address> -node x -drive y -read <parameter index>
```

Syntax for writing drive parameters:

```
sqdriveparam -server <ip address> -node x -drive y -write <parameter index> -data <value>
```

#### Examples

To read the value of the drive rated peak current:

```
sqdriveparam -server <ip address> -node x -drive y -read 0x3
```

Set the encoder resolution to 2048:

```
sqdriveparam -server <ip address> -node x -drive y -write 0x7 -data 2048
```

## 9.3.4 Accessing an Entire Parameter Set

Use the sqDriveConfig Utility for reading or writing an entire set of drive parameters. The utility uses a Drive Parameter Map File that contains definitions and properties of the drive parameters. The map file needs to match the drive processor firmware version in terms of version number and in terms of the set of supported parameters.

Syntax for reading an entire set of parameters to a file:

```
SqDriveConfig -server <ip address> -node x -drive y -get
<destination file name> -map <map file name>
```

Syntax for writing an entire set of parameters from a file:

```
SqDriveConfig -server <ip address> -node x -drive y -set
<source file name> -map <map file name>
```

Map files for each drive are delivered with the MPI installation and can be found in the XMP\bin subdirectory. In addition, the map file matched to a specific version of drive firmware can be downloaded from the Drive Firmware section. Simply select the drive and retrieve the appropriate firmware and map file information.

### 9.3.4.1. DRIVE PARAMETER MAP FILE

The drive parameter map file is a text file that contains a list of valid drive parameters for a particular drive model. The file contains five sections: File Header, Drive Identification, Parameter Identification, Configuration, and File Footer. Each Drive Identification section is matched with a Parameter Identification and Configuration section. Depending on the firmware version, there may be more than one parameter section.

The format is described below. A sample map file, for the S200-SynqNet drive is shown in the Sample Drive Map File.

#### File Header

The file header contains one line:

```
#MPI Drive Parameters
```

#### Drive Identification Section

This section contains one line, which describes the name of the manufacturer, the model number, and the drive firmware versions that are compatible with the drive parameter list.

```
#"Manufacturer and Model" "drive firmware version" (file-
specific)
```

For the S200-SynqNet, the "Manufacturer and Model" text will always be "Kollmorgen S200."

#### Examples

```
# "Kollmorgen S200" "2.0a"
```

#### Parameter Identification Section

This section contains definitions of the parameters that are valid for the firmware version(s) listed in the Drive Identification section. The section begins with the following header line:

```
#parameters
```

Each line in this section contains the following parameter identification information.

Parameter Identification	
Name	Description
number	Drive parameter number (in hex).
name	Drive parameter name, or command string.
read/write access	Read/write (rw) or read-only (ro).
data type	One of the pre-defined data types (see the Data Types table).
values	List of valid values, range of valid values, or an address.
default value	Parameter value to be used if value is not specified.
help string	Simple string to provide help to user.

All service commands and drive parameters are accessed over the service channel as 32-bit quantities, but the 32 bits of data can represent different types of data. To support various data types with generic software tools, the supported data types have been predefined. Here are the data type names that are supported for the drive parameter map file.

Data Types	
Name	Description
unsigned8	An 8-bit unsigned binary number.
unsigned16	A 16-bit unsigned binary number.
unsigned32	A 32-bit unsigned binary number.
signed8	An 8-bit binary, twos-complement number.
signed16	An 16-bit binary, twos-complement number.
signed32	An 32-bit binary, twos-complement number.
hex32	An 32-bit unsigned hexadecimal number (same as unsigned32 but displayed as hexadecimal).
enumerated	A list of numbers 1, 2, 3, 4 where each number has a specific meaning (same as unsigned32 but displayed as a selectable list).
mask	A set of bits 1, 2, 4, 8 where each bit has a specific meaning (same as unsigned32 but displayed as a set of selectable flags).
character	An ASCII character.
Single	A 32-bit floating point number according to IEEE754.
action	A write-only parameter where the data is always zero. Performs an action/command on the drive that does not need any data.

A few examples from the CD SynqNet and the PicoDAD are:

0x01	MBEMFCOMP	rw signed 16	{0-100}	0 "Back EMF compensation percentage"
0x02	DICONT	ro signed 16	{10-1100}	0 "Drive rated continuous current"
0x03	DIPEAK	ro signed 16	{10-1100}	0 "Drive rated peak current"
0x04	ICONT	rw signed 16	{0-1000}	0 "Application rated continuous current"

## Parameter Configuration Section

The Configuration Section lists the parameters that will be downloaded to a drive from a drive configuration file, or uploaded from a drive to a configuration file, using the sqDriveConfig Utility. The section begins with the following header line:

```
#config
```

The header is followed by a list of drive parameter names (names only; not values). For example:

```
ARF0
ARF1
BAT_F_DIS
CMD_F0
```

// – Indicates a comment and the line is ignored by the parser.

The sequence of names does not need to correspond to the sequence in the Parameter Identification section. However, it does need to follow the sequence of parameters required by the drive.

The configuration section typically ends with a –1. This code is used to instruct the sqDriveConfig Utility to execute a drive CONFIG after the parameters have been downloaded. After changing certain drive parameters (primarily motor and feedback parameters), the drive will be in a "Not Configured" state and will require the execution of CONFIG to configure the drive.

## File Footer

#end – Designates the end of the parameter map file.

### 9.3.4.2. DRIVE CONFIGURATION FILE

The drive configuration file contains the actual parameter values. The file has a one-line header that identifies the following:

- node number
- drive number
- drive identification
- firmware version number

The drive configuration file must match the map file, the firmware version of the drive being addressed, and the location of that drive on the SynqNet network.

Here is an example of the header line:

```
# sqNode[3] drive[0] "Kollmorgen S200" "2.0a"
```

This header shows that the file contains data for the S200-SynqNet drive that is located on **Node 3**. The header also specifies that the drive has firmware version **2.0a**. If the drive does not have this version, an error message will be displayed.

The rest of the file consists of parameter command strings followed by their values. For an example, see the Sample Drive Map File.

The easiest way to create a template for the drive configuration file is to read a file of data from a drive. It is important that the map file exists and is valid.

## 10 ACCESSORIES, CONNECTOR KITS, AND CABLES

S200 drives are not shipped with a connector kit or serial communication cable. Customers are responsible for ordering the proper connector kit(s) and other accessories necessary for drive setup. For assistance in proper selection, please contact a sales representative.

### 10.1 ACCESSORIES

Part Number	Description
P7S2-232-9D	RS232 serial communication cable (DB-9 to Mod Jack) -- 6 feet.
768-026902-01	Terminal Block adaptor for J4 I/O connector.
MSM20001	S200 Base/SynqNet User Manual.

### 10.2 CONNECTOR KITS

Part Number	Description
CK-S200-MF	Motor power and feedback mating connectors for S200 AC or DC units.
CK-S200-IP-DC	I/O and input power mating connectors for base S200 DC drive.
CK-S200-IP-DC-TB	I/O and input power mating connectors for base S200 DC drive with terminal block adaptor for I/O connector.
CK-S200-IP-AC	I/O and input power mating connectors for base S200 AC drives S20260, S20360, S20660.
CK-S200-IP-ACL	I/O and input AC control power mating connectors for base S200 AC drives S21260, S22460.
CK-S200-IP-AC-TB	Terminal block adaptor I/O connector and input power mating connectors for base S200 AC drives S20260, S20360, S20660.
CK-S200-IP-ACL-TB	Terminal block adaptor I/O connector and input AC control power mating connectors for base S200 AC drives S21260, S22460.
CK-S200-SQ	Option card SynqNet (-SRS, -SDS) I/O, Aux Feedback mating connectors.
CK-S200-SQ-TB	Option card SynqNet (-SRS, -SDS) terminal block adaptors for I/O, Aux Feedback.
CK-S200-CNDN	Option card CD/DN and I/O mating connectors for S200.
CK-S200-CNDN-TB	Option card CD/DN and I/O mating connectors, terminal block adaptors for I/O and feedback connector for S200.

## 10.3 CABLES

Part Number	Description
P7S2-232-9D	RS232 serial communication cable (DB9 to Mod Jack) -- 6 feet.
CF-DA0111N-XX-X	Feedback Cable "value series" - Euro connector at the motor end to IEEE1394 connector at the drive end for Smart Feedback Device support.
CP-102ACN-XX-X	Power Cable "value series" - Molex connector at the motor end to S200 crimp pin pluggable connector at the drive end.
CP-102AAAN-XX-X	Power Cable "value series" - Euro connector at the motor end to S200 crimp pin pluggable connector at the drive end.
CC-D01CO2N-XX-X	Composite Cable "value series" - Single Molex connector at the motor end to IEEE1394 connector and S200 crimp pin pluggable connector at the drive end for Smart Feedback Device and power support in the single cable.
CC-D01AO2N-XX-X	Composite Cable "value series" - Euro style connector for power and feedback at the motor end to IEEE1394 connector and S200 crimp pin pluggable connector at the drive end for Smart Feedback Device and power support in a single cable. Only available on AKM3 and AKM4 series motors.

# 11      **DIAGNOSTICS AND TROUBLESHOOTING**

The S200 drive incorporates:

- Output motor short circuit protection line-to-line, line-to-neutral and line-to-PE.
- Internal monitoring of the power stage heat sink temperature for drive over-temperature.
- Bus over-voltage and under-voltage detection.
- Control under voltage detection.
- Excessive current  $I^*t$  fault/foldback. Depending on drive setup, when excessive  $I^*t$  is detected either the peak output current limit is dropped to 67% of maximum or the drive faults.
- Excessive motor current  $I^2t$  protection.
- Invalid smart feedback device (SFD) shaft feedback signal.
- Motor over temperature on SFD equipped motors.
- Option card detected faults e.g. Aux Feedback interface faults.



## 11.1 DRIVE FAULT CODES

The Drive Status LED is located on the front panel. The drive status and fault codes are communicated by the state of the LED.

Status LED	Drive Status																																										
<b>ON</b>	Drive is enabled, not faulted. Output stage is enabled and controlling power to the motor																																										
<b>OFF</b>	Drive control power input is not powered or has insufficient voltage applied																																										
<b>Fast Blinking</b>	Drive is not enabled, not faulted. Output stage is not enabled – no power to the motor																																										
<b>Slow Blinking</b> (with a pause)	Drive is blinking a fault code The number of blinks corresponds to the fault code as follows: <table border="1" data-bbox="592 569 1198 1205"> <thead> <tr> <th>Blink Count</th> <th>Fault Code</th> </tr> </thead> <tbody> <tr><td>1</td><td>Not Fault</td></tr> <tr><td>2</td><td>Motor Over Temp</td></tr> <tr><td>3</td><td>Drive Over/Under Temp</td></tr> <tr><td>4</td><td>Drive I<sup>2</sup>t Too High</td></tr> <tr><td>5</td><td>Motor I<sup>2</sup>T Too High</td></tr> <tr><td>6</td><td>Optional Battery low</td></tr> <tr><td>7</td><td>Bus Over Voltage</td></tr> <tr><td>8</td><td>Bus Under Voltage</td></tr> <tr><td>9</td><td>Motor I-I or I-n Short</td></tr> <tr><td>10</td><td>Output Over Current</td></tr> <tr><td>11</td><td>Hall Fault</td></tr> <tr><td>12</td><td>SFD Configuration Error</td></tr> <tr><td>13</td><td>SFD Short</td></tr> <tr><td>14</td><td>SFD Motor Data Error</td></tr> <tr><td>15</td><td>SFD Sensor Failure</td></tr> <tr><td>16</td><td>SFD UART Error</td></tr> <tr><td>17</td><td>SFD Communication Error</td></tr> <tr><td>18</td><td>Option Card Watch Dog Timeout</td></tr> <tr><td>19</td><td>Position Error Too Large</td></tr> <tr><td>20</td><td>OC Fault</td></tr> </tbody> </table>	Blink Count	Fault Code	1	Not Fault	2	Motor Over Temp	3	Drive Over/Under Temp	4	Drive I <sup>2</sup> t Too High	5	Motor I <sup>2</sup> T Too High	6	Optional Battery low	7	Bus Over Voltage	8	Bus Under Voltage	9	Motor I-I or I-n Short	10	Output Over Current	11	Hall Fault	12	SFD Configuration Error	13	SFD Short	14	SFD Motor Data Error	15	SFD Sensor Failure	16	SFD UART Error	17	SFD Communication Error	18	Option Card Watch Dog Timeout	19	Position Error Too Large	20	OC Fault
Blink Count	Fault Code																																										
1	Not Fault																																										
2	Motor Over Temp																																										
3	Drive Over/Under Temp																																										
4	Drive I <sup>2</sup> t Too High																																										
5	Motor I <sup>2</sup> T Too High																																										
6	Optional Battery low																																										
7	Bus Over Voltage																																										
8	Bus Under Voltage																																										
9	Motor I-I or I-n Short																																										
10	Output Over Current																																										
11	Hall Fault																																										
12	SFD Configuration Error																																										
13	SFD Short																																										
14	SFD Motor Data Error																																										
15	SFD Sensor Failure																																										
16	SFD UART Error																																										
17	SFD Communication Error																																										
18	Option Card Watch Dog Timeout																																										
19	Position Error Too Large																																										
20	OC Fault																																										

### Fault Generation

The following sequence occurs when the protection circuits generate a fault.

- One or more faults are detected by the control logic
- The fault source is latched – only for latched faults
- The output stage is disabled.
- The LED indicates the appropriate fault code.
- For non-latched faults when the fault condition is cleared the drive re-enables automatically.

Latched faults are cleared by setting the Enable/ input to the disable state or by cycling (off/on) the Control Power.

**NOTE:** The large bus capacitors store substantial energy. To use the control power to reset a fault, the power should be removed for at least 30 seconds to ensure that the fault resets. Self-resetting faults disable the drive and do not return it to normal operation until 50-100 ms after the fault condition clears.

When multiple faults occur, the highest priority fault is reported. After that fault is cleared and the drive is reset by cycling the enable input, the next highest priority fault that still exists will be displayed.

## 11.2 DIAGNOSTICS

The following table lists the S200 fault codes and possible causes of the fault condition.

Status LED Blink Code	Fault Description	Possible Cause
ON	No faults, power stage Enabled	Normal Operation
OFF	Control power not applied or insufficient control power applied	Loose or open circuit wiring of control power input. Low input voltage to control power supply.
Fast Blink	No faults, power stage Disabled	Hardware or Software Enable inactive, to enable drive apply hardware enable and set software enable.
1	Not Assigned	
2	Motor Over Temp  Motor temperature exceeds allowed limit	High ambient temperature at motor. Insufficient motor heat sinking from motor mounting. Operating above the motor's continuous current rating. Motor temperature sensor failure or not connected.
3	Drive Over/Under Temp  Temperature of drive heatsink/chassis is outside of allowed limits	High or low drive ambient temperature. Restriction of cooling air due to insufficient space around unit.. Operating above the drive's continuous current rating.
4	Drive I*t Too High The product of the drives output current multiplied by time has exceeded allowed limits.  If current foldback is enabled the drive peak output current automatically reduces to 0.67% of <b>DIpeak</b> . If foldback is not enabled, the drive will fault.	Mechanically-jammed motor. Motion profile acceleration requires peak current for too long of a time duration. Machine load on the motor increased by friction. Wiring problem between drive and motor yielding improper motion. Motor commutation error. Drive under-sized for application, friction or load.
5	Motor I <sup>2</sup> *t Too High  Motor current amplitude squared multiplied by time has exceed allowed limits	Mechanically-jammed motor. Motion profile acceleration requires peak current for too long of a time duration. Machine load on the motor increased by friction. Motor commutation error. Motor under-sized for application, friction or load.
6	Optional Battery low  Optional fault used to indicate SFD battery supply voltage is low	Battery low fault enabled and battery is not installed. SFD Battery backup voltage is low.

Status LED Blink Code	Fault Description	Possible Cause
7	Bus Over Voltage - Self Resetting  The BUS voltage has exceed the upper threshold limit	AC Line voltage (AC unit) or DC bus power supply voltage (DC unit) is too high. Regenerative energy during deceleration is causing the BUS to rise: On AC Drives add regen resistor. On S200 DC input drives external BUS capacitor is too small; add capacitance.
8	Bus Under Voltage - Self Resetting  S200 DC drive fault only  BUS voltage is below specified 20 VDC minimum	On S200 DC input drives: BUS voltage is too low. BUS voltage is pulled down during high acceleration or loading. External BUS capacitor is too small.
9	Motor I-I or I-n Short  Line-to-Line, Line-to-Neutral or Line-to-PE short on the motor output causing an instantaneous over current.	Motor power wiring short circuit - line-to-ground / neutral. Motor cable short line-to-line. Motor power cable length exceeds the data sheet specification causing excessive motor line-to-earth ground/neutral capacitance. Internal motor winding short circuit. Motor L too small. <b>KIP</b> set too large.
10	Output Over Current	Insufficient motor inductance <b>KIP</b> or <b>KII</b> improperly set causing excessive output current overshoots.
11	Hall Fault  Valid only when drive is set for 6 Step (Hall feedback) operation	Invalid configuration. Motor overspeed. Invalid hall state. Invalid hall transition.
12	SFD Configuration Error	SFD UART error during SFD initialization. Bad motor data check sum. The drive will attempt to initialize the SFD up to 4 times. If it fails this error is reported.
13	J3 FB +5V Short  Excessive current drain on SFD +5 supply output	Excessive loading on SFD +5 supply. Short in the feedback cable on SFD +5 (J3-1) to ground.
14	SFD Motor Data Error Motor data in SFD is outside drive limits or is inconsistent	Motor and Drive are not compatible. Auto setup calculation yielded a desired parameter value outside valid range. Incorrect/inconsistent motor data loaded into the SFD.
15	SFD Sensor Failure	Internal SFD failure. Excessive electrical noise in the drive environment causing communications interference.
16	SFD UART Error	Internal SFD failure.

<b>Status LED Blink Code</b>	<b>Fault Description</b>	<b>Possible Cause</b>
17	SFD Communication Error	Feedback cable not connected at the drive or at the motor. Feedback cable shield not connected. Defective feedback cable Internal SFD failure. Excessive electrical noise in the drive environment causing communications interference.
18	Option Card Watch Dog Time out	Communication error between option card and main board.
19	Position Error Too Large	Check <b>ExtFaults</b> : <b>ExtFaults</b> = Step size over flow means <b>GearOut/GearIn</b> is too large. <b>ExtFaults</b> = Position error over flow means that the following error, = <b>PosErr</b> , has exceeded $\pm 128$ revs. Check if the motor is stalling or if the commanded speed is higher than the motor can achieve at the present bus voltage.
20	Option Card Fault	Check <b>ExtFaults</b> : If <b>ExtFaults</b> is <b>AuxFBFault</b> , then the AuxFB device is in error. Check the AuxFB faults: <b>AuxFBEnDatFit</b> , <b>AuxFBPTCFit</b> or <b>AuxFBSCDFit</b> . Check to make sure that the drive is set up for the correct feedback device and that the device is functioning correctly. If <b>ExtFaults</b> is "No Extended Fault," then this was a fault induced by the controller, such as <b>SynqLost</b> .

## 11.2.1 Fault Generation

The following sequence occurs when the protection circuits generate a fault.

- One or more faults are detected by the control logic.
- The fault source is latched – only for latched faults.
- The output stage is disabled.
- The LED indicates the appropriate fault code.
- For non-latched faults. When the fault condition is cleared, the drive re-enables automatically.

Latched faults are cleared by setting the Enable/ input to the disable state or by cycling (off/on) the Control Power.

**NOTE:** The large bus capacitors store substantial energy. To use the control power to reset a fault, the power should be removed for at least 30 seconds to ensure that the fault resets. Self-resetting faults disable the drive and do not return it to normal operation until 50-100 ms after the fault condition clears.

When multiple faults occur, the highest priority fault is reported. After the fault is cleared and the drive is reset by cycling the enable input, the next highest priority fault that still exists will be displayed.

## APPENDIX A – DC POWER SUPPLY DESIGN

### A.1 DESIGN

This section has additional considerations for DC power supplies.

#### A.1.1 Single Power Supply Operation

A single power supply can be used to provide main or motor power and control power for the DC power input. The voltage range of a single supply is 20 V to 90 V.



**The drive can be damaged if the supply voltage exceeds 90 V, even briefly. The DC level plus transients plus regenerative pump up MUST NEVER exceed 90 V.**

Wire the single supply +terminal to J1-3 (+Bus) and to J1-1 (+CTRL) and the power supply –terminal to J1-2 (Bus/Ctrl Gnd). This power supply is typically unregulated, but a regulated supply can also be used. The power supply outputs must be isolated from the power line. See Regulatory Information for more details on isolation requirements. Wire both the power supply negative terminal and the drive chassis to earth for safety.

The maximum continuous and peak (3 sec) main power and current at 75 V bus for the S200 DC drives is shown in the table below.

	3/9 ARMS S200 DC	6/18 ARMS S200 DC
<b>Main (continuous)</b>	250 watts	500 watts
	3.33 ADC at 75 V	6.67 ADC at 75 V
<b>Main Peak (3 sec)</b>	750 watt	1,500 watt
	10 ADC at 75 V	20 ADC at 75 V

The next figures provide representative connection diagrams and some detailed recommendations.

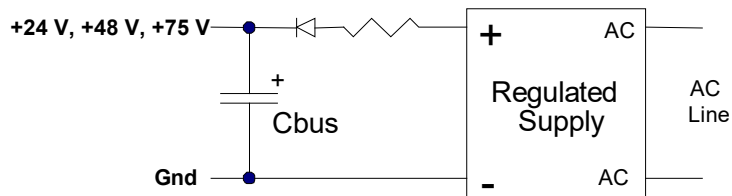

**(Optional) Regulated, Isolated Supply**

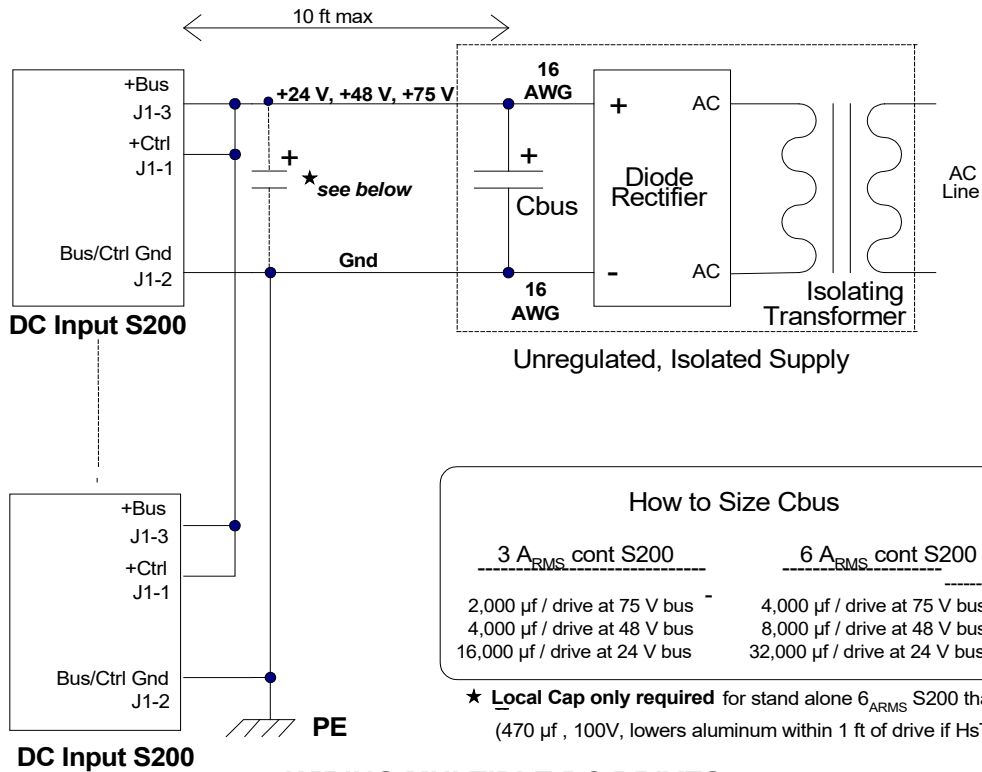

### WIRING MULTIPLE DC DRIVES



**CAUTION**

*An appropriately-sized output capacitor in the main power supply is the key to economically delivering high peak power. In most applications, the capacitor supplies much of the peak power needed to accelerate the motor and inertia (under 20 ms). It also lowers the cost of the supply by reducing its silicon current. In addition, it also absorbs regenerated energy with a limited pump up of voltage and stabilizes the bus voltage for better dynamics.*



**NOTE**

*While the maximum peak-to-continuous power capability is 3:1, most applications have much higher ratios. The requirement that the main supply have a high peak-to-continuous power ratio is very important in selecting or designing the power supply.*

## A.1.2 Main Supply Output Capacitance (J1-3 to J1-2)



NOTE

*The location of the main output capacitor is not critical. Up to 10 ft from the drive is an acceptable length, as long as the wire is sized so resistive drops at peak current are low. Voltage clipping of the inverter can cause the peak bus current to equal the motor current. A good rule is to size the bus wiring for  $18 \text{ ARMS} \times r_t(2) = 25.4 \text{ ARMS}$  peak per drive. Use at least 16 AWG. The inductance of the bus and ground wiring is not critical because the internal drive bus capacitance can handle all the PWM current in most cases.*

Servos put high peak power demands on the power supply. The easiest and best way to build a power supply to deliver and absorb pulses of peak power is for the supply to have an appropriately-sized output capacitor.

Capacitance Requirements	
3/9 ARMS DC S200	6/18 ARMS DC S200
2,000 $\mu\text{f}$ / drive at 75 V bus	4,000 $\mu\text{f}$ / drive at 75 V bus
4,000 $\mu\text{f}$ / drive at 48 V bus	8,000 $\mu\text{f}$ / drive at 48 V bus
16,000 $\mu\text{f}$ / drive at 24 V bus	32,000 $\mu\text{f}$ / drive at 24 V bus

This can be the output capacitor of an unregulated power supply or a capacitor in parallel with the output of a regulated supply. In most cases, this capacitor does not need to be close to the drive, so a single capacitor can be shared by multiple drives. This capacitor does several jobs:

1. **Bus capacitance absorbs net regenerated mechanical energy from the inertia when the motor decelerates.**

If the bus capacitance is sufficient, regeneration causes a controlled, limited rise in bus voltage and the over-voltage fault is not tripped.



NOTE

*If the regenerated mechanical energy is high, additional bus capacitors can be added in parallel. The bus capacitance can be increased almost without limit.*



NOTE

*The over-voltage fault is a non-latching fault that turns off the inverter transistors when the bus voltage is above the over-voltage threshold. An over-voltage fault trip interrupts the regeneration of mechanical energy back to the bus. This limits the bus voltage rise and protects the drive. However, it interrupts motor torque, so the machine cycle is affected. In most cases it is undesirable to allow the bus voltage to pump up to the over-voltage fault threshold.*

In many applications, much or all of the rotational mechanical energy is dissipated as heat in the motor windings when the motor decelerates. The maximum regenerated rotation energy back to the bus occurs (counter-intuitively) during a low torque deceleration from high speed. In this case, the resistive losses in the motor are low. If mechanical drag is low, much of the stored rotational energy is regenerated to the bus.

2. **Bus capacitance absorbs net regenerated inductive energy from the motor winding when the drive is disabled or faulted.**

The worse case, regenerated inductive bus voltage rise is a trip of the bus over-voltage fault when decelerating the motor at full torque. Tripping the bus over-voltage fault, while stopping the flow of regenerative mechanical energy back to the bus, causes a fraction of the inductive energy stored in the windings to regenerate to the bus, causing the bus voltage to go higher than the over-voltage threshold. If there is insufficient bus capacitance to absorb this energy, the bus voltage rise is excessive and can damage the drive.



NOTE

*Failure to provide adequate external capacitance on the main bus can damage the drive. The regeneration of motor inductive energy allows some pump up of the bus voltage above the bus over-voltage threshold.*

3. **Bus capacitance improves motor dynamics by holding the bus voltage stable during acceleration.**



An adequately sized bus capacitor helps provide the high peak bus current needed for rapid motor acceleration with minimum bus voltage sag. If the bus voltage sags excessively during acceleration, inverter voltage saturation occurs with loss of motor torque.

4. **Bus capacitance lowers peak current requirements in the silicon of the power supply.**

Sizing the power supply for average power, rather than peak power, lowers power supply cost and size.

5. **In most cases, a bus capacitor does not need to be mounted close to the drive.**

The inductance of the bus and ground wiring is not critical because the internal drive bus capacitance generally handles all the PWM current of the drive. A local capacitor is not needed in the following cases:

- 3/9 ARMS DC S200
- 6/18 ARMS DC S200 with **HSTemp** less than 65° C
- 6/18 ARMS DC S200 mounted adjacent to other S200 drives with main bus supplies tied locally together. The internal bus capacitors of the adjacent drives should provide the needed capacitance.

The exception is a single, isolated 6/18 ARMS DC S200 drive running hot (HSTemp > 65° C). In this case, connect across the bus within 1 ft of the drive, using twisted wire, a 470 µf (min), 100 V, low ESR, and an aluminum bus capacitor.

6. **Bus capacitor for multiple drives**

A conservative rule is to scale up the recommended output capacitance for one drive by the number of drives. If this value is too large, the capacitor can be calculated from energy flows. See the A.4 Bus Energy & Power Numerical Examples.

***Bus capacitance can be tweaked experimentally. Increase bus capacitance if there are overvoltage trips. In general, there is sufficient bus capacitance if the bus voltage variation is ± 5 V (from 75 VDC) during the machine cycle. Check the bus voltage with an oscilloscope. Scope ground on J1-2 (Bus/Ctrl Gnd) and probe on J1-3 (+bus), Hor: 5 ms / div.***



**NOTE**



**NOTE**

***Some bus voltage variation is normal and required for the output bus capacitor to supply or absorb energy.***

7. **Bus over-voltage fault (non-latching)**

If regeneration is too high while bus capacitance is too low, the bus voltage rises to the bus over-voltage fault threshold and disables the drive transistors. It typically takes 1 to 2 ms for the motor current and torque to go to zero. After it has reached zero, there is no further rise in the bus voltage. When the bus capacitors discharge to below the over-voltage threshold by a hysteresis value, the over-voltage fault is cleared and normal operation resumes. While this protects the drive by limiting the bus voltage rise, it may not be desirable because it interrupts normal motor torque.

8. **Unregulated power supply**

External bus capacitance requirements are usually met by the output capacitor in an unregulated power supply, as long as there is no diode between the drives and bus capacitor. The same capacitor that filters the 120 Hz or 360 Hz line ripple also provides energy leveling and regeneration absorption capability.

### 9. Regulated power supply

Some regulated supplies do not tolerate an increase in voltage above the supply voltage set point. In this case, insert a diode between the positive supply terminal and the positive capacitor terminal to prevent reverse current flow into the supply. The diode should be a rectifier diode with a voltage and current rating equal to or greater than the supply.

A low ohm ( $< 1 \Omega$ ) power resistor between the power supply and the capacitor may be desirable. By reducing the stiffness of the voltage across the capacitor, it enhances the ability of the capacitor to supply current to the drive during motor acceleration and prevents the current limit of the regulated supply from cutting in.

### 10. Bus wire resistance

Bus wire current is the sum of DC current providing power to the drive and AC current between the drive and external capacitor. The wire between the drive and external bus capacitance should be a low enough resistance, so peak currents do not cause excessive voltage drop in the wire. Peak instantaneous bus current can be up to 25 A per drive. Size the positive Bus wiring to minimize the peak voltage drop. As a general guide, use no smaller than 16 AWG wire to span 10 feet from the drive to the shared energy leveling capacitor.

The AC and DC bus currents also flow in the Control or Bus terminal. Size the ground wire to the drive to be no smaller than the positive Bus wire. A larger wire size yields a cleaner ground.

If a separate control supply is used, connect the control supply ground and main bus supply ground together at or near the drives not at the supplies.

### 11. Bus wire inductance and bus resonance

The time domain of motor-related energy flow is measured in milliseconds. The inductive voltage drop in the bus and ground wiring for these times is small. For this reason, the energy leveling bus capacitor does not need to be located near the drive and a single bus capacitor can be shared by multiple drives.



**NOTE**

#### ***Be aware of bus resonance.***

Current can oscillate between capacitors in any distributed DC power system with the capacitor located apart and connected in parallel with wires. The capacitors and wiring inductance form an underdamped LC circuit that can ring when excited by PWM currents.

The easiest way to monitor the current in the bus wiring of the drive is with a current probe. The ringing occurs if the current probe shows a large ( $> 10 \text{ A}$ ) quasi-sinusoidal current in the 1 to 10 kHz range. While more difficult to see in voltage, it does cause small sinusoidal voltage (few volts) to occur across the drive positive Bus (J1-3) to Gnd (J1-2) terminals.

Occasional bursts of bus ringing are usually not too serious, but sustained or too frequent ringing is undesirable because high currents can cause heating of wires and capacitors.

The simplest way to squelch bus ringing is to lower or change the inductance of the bus wiring with the following:

- a. Move the external bus capacitor closer to the drive

***or***

- b. Twist the bus and ground wires between the drive and supply

***or***

- c. Add extra capacitance (470  $\mu\text{f}$  or more) near the drive bus terminals

### 12. Recommended External Bus Capacitors

Aluminum electrolytic, computer-grade, screw top cans are available with panel mount hardware. The voltage rating should exceed the maximum bus voltage. Choose a cap with a 100 V rating for operation at 75 V bus nominal. The important capacitor

parameter is capacitance (energy storage), so an 85° C, general-purpose type (such as are listed below) is acceptable.

**Panasonic G-AA series**

1.375 x 4.125	8,200 µf 100 V	EEGAA2A822CKE
2 x 4.125	22,000 µf 100 V	EEGAA2A223FKE
3 x 4.125	47,000 µf 100 V	EEGAA2A473HKE

**Cornell Dubilier DCMC series**

1.375 x 4.125	8,600 µf 100 V	DCMC862U100AC2B
2 x 4.125	20,000 µf 100 V	DCMC203U100BC2B
3 x 4.125	49,000 µf 100 V	DCMC493U100DC2B

**United Chemicon U36D series**

1.375 x 4.625	8,200 µf 100 V	U36D100LG822M35X117HP
2 x 4.625	18,000 µf 100 V	U36D100LG183M51X117HP
3 x 4.625	47,000 µf 100 V	U36D100LG473M76X117HP

## A.2 TWO POWER SUPPLY OPERATION

Powering the drive control power separately from the bus power has the advantage that fault and status information is preserved when bus power is down for safety.

Wire the control supply positive terminal to J1-1 (+CTRL) and the control supply negative terminal to J1-2 (Bus/Ctrl Gnd). Wire the main supply positive terminal to J1-3 and its negative terminal to J1-2. J1-2 is a shared ground for control power and main power. Separate ground wires from the two supplies should join at or near the shared drive ground pin (J1-2).



***The drive can be damaged if the supply voltage exceeds 90 V, even briefly.***

### A.2.1 Control Supply (J1-1 to J1-2)

The voltage range of the control supply is + 10 to + 90 V. This supply can be either unregulated or regulated. However, it must be isolated from the power line as its negative terminal is typically earthed for safety and commoned with main power negative terminal.

For reliable starting, the control supply should have a peak power rating of at least 20 W. A typical continuous control power drawn by an S200 DC drive is 2 to 8 W. A single, relatively low power, low voltage supply (+ 12 V or + 24 V) can provide control power and I/O power for multiple drives.

## A.3 MULTI-AXIS CONSIDERATIONS

In multi-axis applications, the drive's power terminals can either be wired separately to the power supplies or paralleled locally (daisy-chained) and then wired to the power supplies. In the latter case, increase the wire size to handle the higher current.



***Locally paralleling the main power terminals of multiple drives parallels the internal bus capacitors of the drives (200 µf per drive). This allows the PWM currents of the drives to spread out, thereby lowering the temperature of the capacitor in the hottest drive.***

## A.4 **BUS ENERGY & POWER NUMERICAL EXAMPLES**

The energy flows in the drive bus are:

- **In** - Motoring mechanical energy + Motor losses (motor accelerates).
- **Out** - Regenerated mechanical energy – Motor losses (motor decelerates).
- **Out** - Regenerated motor inductive energy (disable or fault).

### A.4.1 **Min. External Bus Capacitance**

Inductance in AKM motors mated to S200s can be as high as 5 mH (line-to-line). The inductive energy stored in a 5 mH motor at 18 ARMS is calculated as:

$$\begin{aligned} E_{\text{winding}} &= 0.75 \times \text{Inductance line-to-line} \times I_{\text{RMS}} \times I_{\text{RMS}} \\ &= 0.75 \times 0.005 \text{ henry} \times 18_{\text{RMS}} \times 18_{\text{RMS}} \\ &= 1.2 \text{ joules} \end{aligned}$$

The bus capacitor needed to absorb the regenerated energy ( $E_{\text{REGEN}}$ ) is sized using the general rule that the energy stored in the capacitor be a minimum of  $5 * E_{\text{REGEN}}$ . This limits the voltage increase on the bus due to regeneration to 10% of the DC value. Using this general rule to find the minimum bus capacitance for the motor in the above example (for simplicity, ignore that a fraction of regenerated inductive energy is dissipated in the motor):

$$\begin{aligned} E_{\text{bus cap}} &= 5 \times 1.2 \text{ joules} = 6 \text{ joules} \\ E_{\text{bus cap}} &= 1/2 C_{\text{bus}} \times \text{DC voltage} \times \text{DC voltage} \end{aligned}$$

Assume the bus DC voltage is 75 volts

$$\begin{aligned} C_{\text{bus}} &= 2 \times E_{\text{bus cap}} / (75 \text{ V} \times 75 \text{ V}) \\ &= 2 \times 6 \text{ joules} / (75 \text{ V} \times 75 \text{ V}) \\ &= 2,133 \mu\text{F} \end{aligned}$$

The internal S200 bus capacitance is 200  $\mu\text{f}$ , which is less than 10% of the required capacitance for energy absorption.

### A.4.2 **Energy from Acceleration Time**

The bus supply for a group of S200 drives must have enough total capacitance to handle brief, high-current bus transient flows (positive and negative) a few milliseconds without excessive bus voltage variation. The peak output power of a 6/18 ARMS DC S200 can be as high as 1.5 kW (1.5 kW = 18 ARMS  $\times$   $\sqrt{2}$   $\times$  60 V (emf + IR)). This is an energy flow of 3 joules for 2 ms or 15 joules for 10 ms.

Mechanical energy is estimated by considering the load to be pure inertia and measuring the velocity transition times. A full torque acceleration or deceleration of an inertia load yields a triangle power pulse with an energy (in joules) half of the peak power (in watts) multiplied by the velocity ramp time (in seconds) from zero speed. Monitor the motor acceleration by mapping velocity and torque to DAC monitor pins (J4-14, 15), and then looking at them with a scope. Set DM1Map to VelFB and DM2Map to IFB. See the I/O Setting tab in S200Tools. At a peak power flow to the shaft of 1 kW = (25 A  $\times$  40 V EMF), the energy delivered vs. acceleration time is:

5 ms	2.5 joules
10 ms	5.0 joules
15 ms	7.5 joules

### A.4.3 Capacitor Energy Absorb/Deliver

The capacitor energy absorbed or delivered for a 5 V change from a 75 bias is:

3 joules for 8,000  $\mu\text{f}$

7 joules for 20,000  $\mu\text{f}$

16 joules for 45,000  $\mu\text{f}$

### A.4.4 Bus DC Input Power

Bus input power can be estimated by adding motor shaft power and motor resistive winding loss. The shaft power equation is:

Shaft power (watt) = Torque (N-m) x Speed (rad/sec)

where rad/sec = rpm/60 x  $2\pi$

The equation for motor resistive (heat) loss is:

Winding loss (watt) =  $1.5 \times R_{\text{line-to-line}} \times I_{\text{RMS}} \times I_{\text{RMS}}$

## APPENDIX B – CABLES

### B.1 LONG CABLES

The DC resistance of long motor power cables steals some of the available voltage when motor current is high. The principal effect of this is some reduction in peak motor power so acceleration and deceleration times can be longer. The cable resistance has no significant effect on lower speed torque or top speed. For most applications, the loss of performance is small with cables up to the maximum cable length specification. Do not operate an S200 DC Input Drive with long cables at the lower end of the bus voltage range because too much of the available voltage is stolen by the cable resistance.

For S200 AC Input Drives, the DC resistance of the motor power cable is rarely an issue because the voltage drop across the resistance is usually a small fraction of the available nominal bus voltage.

For S200 DC Input Drives with long cables and demanding dynamics, the 14 AWG cable is preferred over the 18 AWG cable. Cable voltage drop vs. cable length is shown in the table below.

Cable Voltage Drop vs. Length

Cable Length (meter)	AWG 18 2 x Rphase (ohm)	V line-line 0-peak at 0.866 x 18 ARMS AWG 18 cable	V <sub>LOSS</sub> in cable as a percent of 75 V bus	
			AWG 18 cable	AWG 14 cable
3	0.126	2.77	3.7 %	1.5 %
10	0.413	9.09	12.1 %	4.8 %
25	1.03	22.7	30.3 %	12.0 %
50	(50 m not recommended with DC 6/18 ARMS)		N/A	24.0 %

## B.2 CUSTOM COMPOSITE CABLES

A composite cable has both feedback and power wires within one overall cable jacket. One of the critical requirements for a composite cable is to provide a high degree of isolation between the power and feedback wires. With 240 VAC-connected drives the power wires can have up to 400 V<sub>peak-peak</sub> fast switching PWM waveforms that can couple to the feedback wiring. These coupled signals can cause communication errors between the Smart Feedback Device (SFD) and the drive. Kollmorgen has developed and sells a composite cable that has very good isolation between the power and feedback sections. It is strongly recommended that this raw cable be used for custom composite cable designs. Contact your Kollmorgen sales representative for additional information.

If this cable does not meet your specifications, the following are some guidelines for custom composite cable development.

***Due to the complexity of modeling and understanding cable coupling, a new composite cable needs to be prototyped and tested to have confidence that it will be reliable.***

### 1) Composite cable should have double concentric feedback shields – one shield within another.

The raw composite cable that has been tested and is known to work well with the S200 has the following structure: *double, concentric shields* around the feedback wires, plus an outer shield around the whole cable (see diagram below). This type of raw cable is strongly recommended. Testing shows double, concentric, shielding is ten times better than single shielding at reducing coupling from the power wires to the feedback data wires.

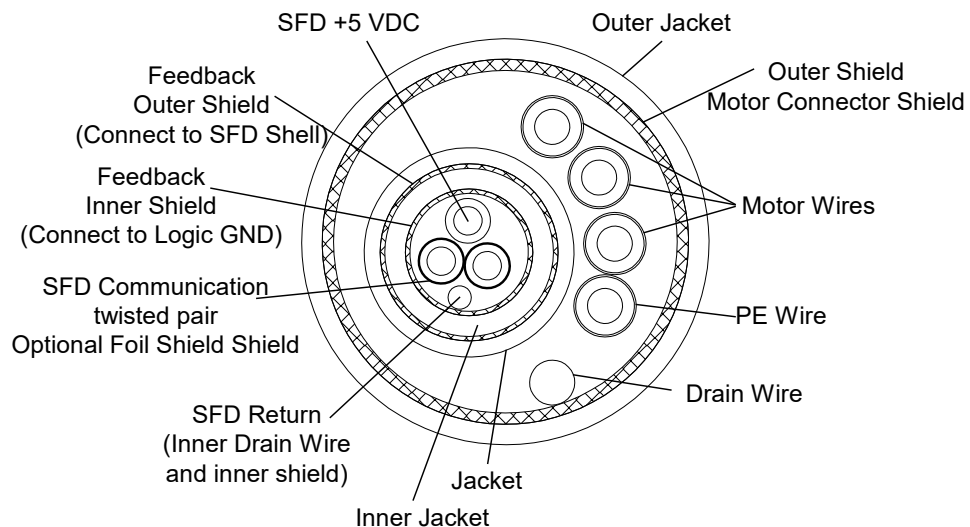

**Composite Cable Cross-Section**



There can be substantial capacitance between the power wires and adjacent feedback shield in a composite cable. Some of the PWM ampere level spikes tend to return in this adjacent shield, affecting the power stage voltage and current drive the feedback shield nearest to the power wires. In a single-shielded feedback cable this driven shield is also around the feedback data wires, so some coupling can occur. With double, concentric feedback shields, the driven shield is the outer of the two feedback shields, and interposed between the driven shield and feedback data wires is the inner feedback shield. Typically, the inner feedback shield is isolated from the connector shells and is connected to the return for the power supply powering the feedback device.



NOTE

***A raw cable with two pairs of twisted, shielded feedback sections inside a composite cable is electrically the same as single feedback shielding. There may physically be two feedback shields in such a cable, but these shields are not concentric. There is only one shield between the power and feedback wires. Whereas the double, concentric feedback shields have two shields between the power and feedback wires.***

### 2) SFD +5 and Gnd Resistance Spec

To insure that the SFD +5 V at the SFD inside the motor is within specification, the voltage drop total in the SFD +5 V wire and SFD +5 V RTN wire must not be greater than 0.5 V at 150 mA. For this reason, a cable requirement is that the total resistance of the feedback SFD +5 V wire plus SFD +5 V RTN wire must be  $< 3.33 \Omega$  (at 20° C). In practice, this means that for long cables, the AWG wire gage needs to be considered.



NOTE

***The inner shield of the a double, concentric feedback cable, when isolated from the terminating connector shells, can also function as a conductor to carry some or all of the SFD +5 V RTN current. This is useful to keep the total SFD +5 and RTN resistance within specification on long cables without having large diameters.***

### 3) Feedback Characteristic Impedance

Kollmorgen's S200 feedback cables are designed to have a feedback data pair differential impedance of  $81 \Omega$  (at 1 MHz). Impedances in the range of 50 to  $100 \Omega$ , while not tested, will likely work properly with the S200.

Two suggestions simplify the design of customer composite cable:

1. Purchase the raw composite cable from Kollmorgen. The cable has good shielding properties.
2. Purchase a composite feedback cable built by Kollmorgen. Review its construction, and test its performance. There are many ways to connect the multiple shields of a composite cable. A good way to understand how the Kollmorgen composite cable is built is to buy a short Kollmorgen S200 composite cable, open it up, and see how the shields at both the motor and drive end are connected.

# APPENDIX C – KOLLMORGEN LINEAR MOTOR WIRING

The S200 Drive with SynqNet option card runs linear motors with a linear feedback device connected to J14. Feedback device possibilities include A quad B incremental encoder with Hall, 1 Vp-p analog Sin-Cos encoder with Hall, and EnDat 2.1/2.2 with absolute linear position. Be sure to set the following drive NV parameters to their proper values.

**AuxFBType** to match the feedback device type connected to J14

**FBSrc** to Option Card to use the J14 Aux Feedback to commutate the motor

**AuxFBDivisor** to the proper value to allow commutation with **DPoles** = 2

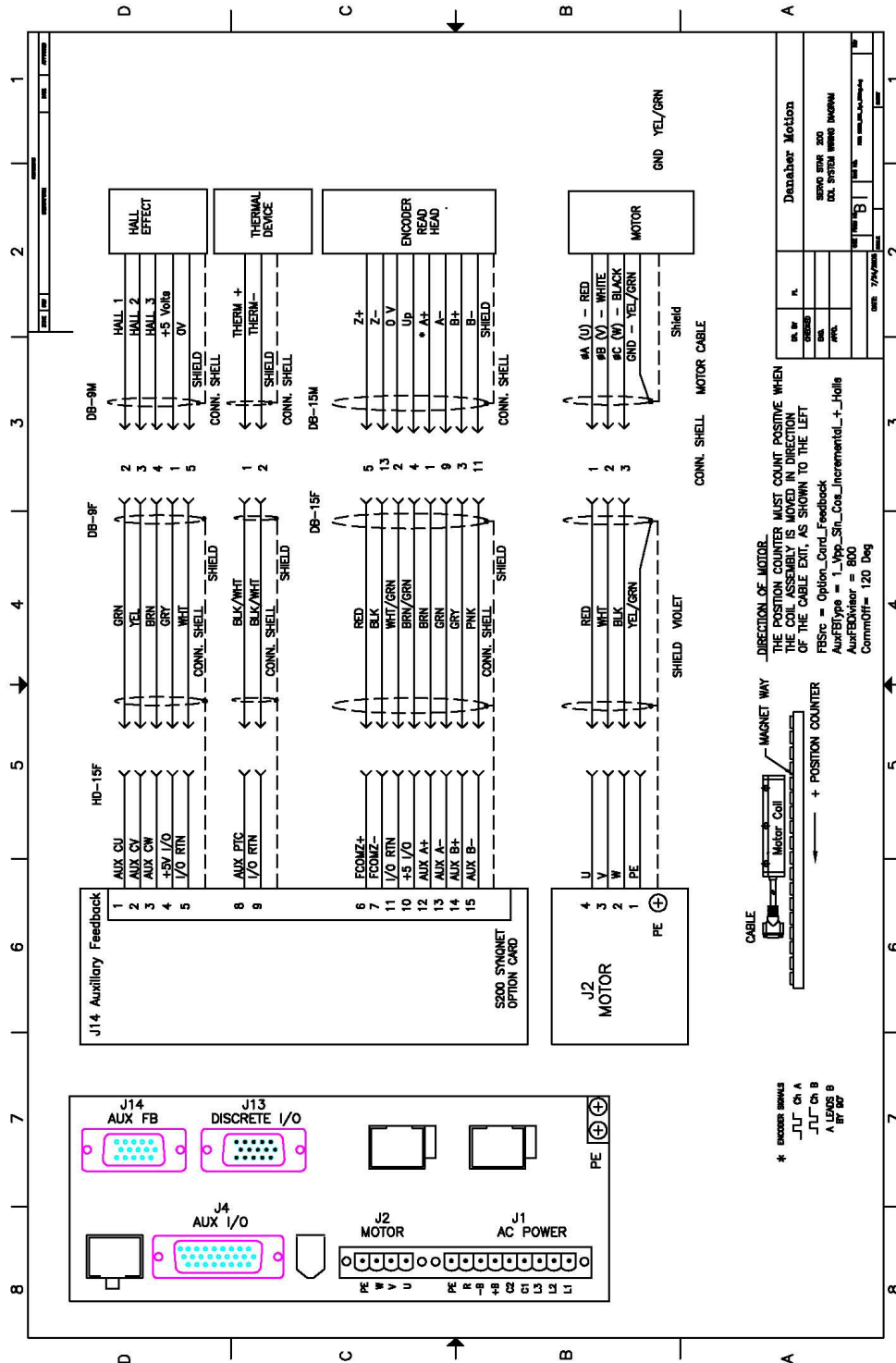

## APPENDIX D – PROCESS TO SETUP NON-KOLLMORGEN MOTORS

The S200 drive family is available with a full set of plug and run accessories and aids for the Kollmorgen AKM family of high performance general purpose rotary servo motors. However, S200 drives should be able to run any three phase permanent magnet motor that has a compatible feedback device.

**Table D.1** Possible combinations of S200 drive and non-catalog or custom motors.

Model	Feedback Type	Wiring	Comment
Base or Base+SynqNet S200	SFD to J3	Chapter 6	Drive to motor Should auto set up
	6-step/Hall to J3	Section 7.3	Wire, set KIP, and run
SynqNet Option Card Only	Incremental + Hall to J14	Chapter 6 power Section 6.9 feedback	Use this Appendix to discover proper wiring and manually set up drive motor parameters
	1 Vp-p Analog Sin-Cos + Hall to J14		
	EnDat 2.1/2.2 from Heidenhain to J14		

For motors not already catalog setup to work with the Kollmorgen S200 drives you need to figure out the wiring between the motor coils, the Hall commutation sensors, and the encoder feedback device to the drive. There is no industry standard definition for the designation of the motor coil terminals, the Hall terminals, or the feedback device terminals. Each manufacturer has their own definitions and the proper wiring between the drive and the motor, feedback device(s) must be found experimentally. Each of these three connection sets can be done multiple different ways.

To get a consistent working set of wiring the motion direction for the motor coils and the feedback device(s) must be the same. The following procedure gives a step by step set of tests to figure out a working set of wiring between a SynqNet equipped S200 drive and the non-catalog motor. During the process the drive is configured for that motor. The goal of each of the below steps is to insure that positive motion as defined by the application is actually positive sequence wiring for each element in the system. For reference, Kollmorgen standard for positive direction is clockwise motion when facing the motor shaft for rotary motors and coil motion in the direction of the motor cable lead exit. In short, you could call the following a procedure to insure the 3 Positives.

## D.1 DETAILED DRIVE MOTOR WIRING DISCOVERY PROCEDURE

### Initial Set Up:

Before wiring the motor, feedback device(s) to the drive turn on control power to the drive and perform a reset to factory defaults if the drive is not brand new. Then, set the feedback device parameters to match the feedback device type. Make sure to NV save these parameters.

With the power off, wire the motor coils, Hall commutation signals, and encoder to the drive in any manner that seems reasonable based on the names of the terminals. For example, wire encoder A+ to drive A+, Hall 1 to drive Hall U, etc. This initial wiring is just a starting point for the process of finding a working set of wiring.

### Positive #1: Monitor and confirm positive encoder wiring:

With the drive control power on and the drive disabled, move the motor manually in the desired direction for positive increasing motion. In S200 Tools monitor PosFB on the Status page of the tool. Be careful because PosFB wraps around every  $2^{16}$  full counts. For SynqNet units the SynqNet master's MoCon encoder count display does not wrap around and increments in the same direction as the drive variable PosFB. If encoder counts do not increment positively, then swap encoder leads J14-13 Aux A+ and J14-14 Aux A-.

**NOTE:** EnDat 2.1/2.2 devices are really two feedback devices in one. At power up a digital communication link gets the initial position and then the analog 1 Vp-p Sin-Cos signals are used to keep track of incremental motion after the absolute position sample. These two directions must agree. So, with EnDat devices positive motion direction is determined by the feedback device and can not be set by application requirement. To see the direction defined by the internal EnDat device power up the drive, feedback device note the position reported by the drive. Then power cycle the drive, move the position and then check the position reported by the drive. If position increased then the moved direction is positive else it was negative.

### Positive #2: Monitor and confirm positive Hall wiring:

Assign the three Hall signals U, V, and W to traces in MoScope on the SynqNet master. For a good visual display on the MoScope software oscilloscope set the scale and offset to Ch U - Gain 6, offset -2; Ch V - Gain 6, Offset 0; Ch W - Gain 6 Offset 2.

With the drive disabled manually move the motor in the positive direction. Hall signals U, V, W should form a three phase set with:

V lagging U by 120 degrees and W lagging V by 120 degrees.

In truth table format, use the following for positive direction movement:

In (Hall UVW format): (101), (100), (110), (010), (011), (001).

If the Hall sequence is not in the expected U then V then W 120 phase order, then Hall wires will need to be swapped.

**NOTE:** In some non-Kollmorgen systems the Halls have 60 degree separation which is equivalent to the Kollmorgen standard with the middle signal Hall V logically inverted. The S200 drive is not compatible with this non-standard Hall format. The inverted logic Hall commutation signal will have to be inverted by circuitry outside of the S200 to get the system to work.

### Positive #3: Monitor and confirm positive motor coil wiring:

This step will be the first time the drive is enabled and the motor will have current in it. Make sure that the motor current loop gain parameter KIP in the drive is set to  $2\pi \times 2000 \times (\text{motor L line-line in Henry})$  and NV saved by using S200 Tools. The drive, SynqNet master will be set to output fixed current vectors independent of actual motor position and the motor will be moved in small increments like a stepper motor.

Set the MEI filter gains to zero. In S200 Tools, set the drive to "stepper motor mode" (no commutation) by setting DPoles = 0. Set the S200 parameter CommOff to 0. Command a positive current in the coil via MoCon by setting a low but nonzero positive and negative current limit (say, +2500 counts each). The rms current in the motor will be this value times the drive Ipeak divided by the scaling number 19336 counts. For example, in an S20660 18 Arms peak drive 2500 corresponds to  $18 \times 2500 / 19336 = 2.3$  Arms. Make sure the current selected is low enough not to overheat the motor coils but high enough to get the motor to move.

Enable the drive and the motor should move to a magnetic pole alignment position. That is, the motor will swing to its pole position, oscillate around that position, and stop. Note the encoder position. Now command a small (try 10) positive CommOff. The resulting motion should be in the positive encoder direction. That is the encoder counts should have increased. If there is enough friction in the system you may need to adjust the current higher, just make sure the current is within the motor coil rating. You can also try going further by setting CommOff to higher angles up to 180 degrees. If the resulting motion was in the negative encoder direction, you will need to swap any pair of motor power leads.

The setup now has the motor coils, the Hall commutation sensor, and the encoder all agreeing on the same positive direction.

Disable the drive.

### Set Commutation Offset Angle:

Zero the current command in the MEI MoCon utility as done in the Positive #3 step.

Restore DPoles to its proper non-zero value. For linear motors this is usually 2 and for rotary motors must be the actual number of magnetic poles per revolution. For linear motors make sure AuxFBDivisor is set correctly to get commutation to work. See Chapter 8 **Advanced Configuration** for help with these NV parameters.

Enable the drive while holding the motor. There should be 0 current command and there should be no force yet. Now apply a small (for example +1000 counts) current command in the MEI MoCon utility as described above. The motor should show a uniform force that doesn't vary as a function of magnetic cycle. Don't worry about the force direction.

Now, try setting CommOff in S200 Tools to -120, 0, +120. Two of these settings will produce force in the wrong (negative) direction at one-half the expected force level. Use the value that produces positive direction force with the higher force level.

**NOTE:** The above last step assumes that the motor was built conventionally and the Hall Commutation logic edges mechanically lined up with the motor line-line back EMF zero crossings. If the Hall commutation sensor has random alignment then you may need to make more careful measures to set CommOff to the optimal value which will give you the most force per amp of drive current.

## Summary:

The S200 drive is now properly configured to run the non-catalog motor. Do an NVSave in the S200 Tools to save the settings, do a file save to save the settings for future reference, and document the working motor to drive wiring. If you would like to help others who might someday run the same motor email the setup file and wiring connections to your Kollmorgen products application engineer so they can share it with others.

## APPENDIX E – VOLTAGE SAG STANDARD – SEMI F47, F42

Semiconductor F47 and F42 standards relate to the ability of equipment to *ride-through* voltage dips of various magnitudes and duration. F47 requires that semiconductor equipment tolerate transient voltage sags or dips on the AC power line. Voltage dip to:

- 50% of nominal for 200 ms
- 70% of nominal for 0.5 second
- 80% of nominal for one second

F42 specifies how to test for compliance with F47. To robust the S200 for F47 type voltage sags, power the S200 using AC line voltage and phasing as described below.

<b>AC S200 Control Power</b>	240 VAC, one-phase
<b>AC S200 Bus Power</b>	Three-Phase, 240 VAC
<b>DC S200</b>	DC power supply operated from three-phase, 240 AC line

### AC Control Power

The use of 240 VAC, single-phase, nominal for control power results in the control voltage remaining within the drive control voltage specification (85 VAC to 265 VAC) during an F47 50% sag (deepest F47-specified sag). Powering the control with 240 VAC also maximizes the ride-through time for larger amplitude sags because more energy is stored in the control bus capacitor.

### AC Bus Power

If three-phase 240 VAC is available for bus power, it provides much better F47 ride-through than either single-phase 240 VAC or 120 VAC because F47 and F42 standards mandate that in a three-phase system, only one phase of the three phases is sagged at a time. If the AC S200 is powered by three-phase 240 VAC, it keeps its bus capacitors reasonably well-charged by pulling power from the one line-to-line voltage that does not sag.

With single-phase AC bus power, a full torque acceleration of the motor to high speed during an F47-mandated voltage sag has the potential to drag the bus voltage down. If only the internal bus capacitors of a 3 A / 9 ARMS S200 are supplying the full 3 kW peak output power, the bus voltage sag rate is 13 V/ms.

A single 10 to 20 ms motor acceleration during a 50% F47 voltage sag has the potential to drop the bus voltage about 50%. Options to handle this problem are:

- a) Limited hold-up time of 20 to 30 ms is achieved by adding additional capacitance on the bus. Wire an external 1,500 uf or higher, 450 VDC, aluminum cap across the +bus to -bus. In this case, simply wire a rectifier or surge limiter between the drive AC terminals and the cap to help charge the external capacitance at power up. The bus voltage does not return to normal until the line returns to normal, so multiple accelerations during the sag are a problem with this option.
- b) Monitor the line voltage and quickly *pause* the machine when the voltage sags.
- c) Combination of a) and b)
- d) A robust, costly option to ride through all F47 mandated voltage sags when three-phase 240 VAC is not available is either to double the peak power capability of the motor/drive system, or to derate the motor's maximum speed 50%. If a motor's top speed can be achieved with a 50% low bus voltage, the worse case F47 voltage sag of 50% is tolerated with little or no effect on motor performance.
- e) If three-phase power is available within the plant, but at higher voltage than 240 VAC, consider adding a power transformer to step it down to 240 VAC for use as AC bus power for the S200 drives in the machine. This is also a robust option.

## APPENDIX F – USING A VOLTAGE DOUBLER MODE DRIVE

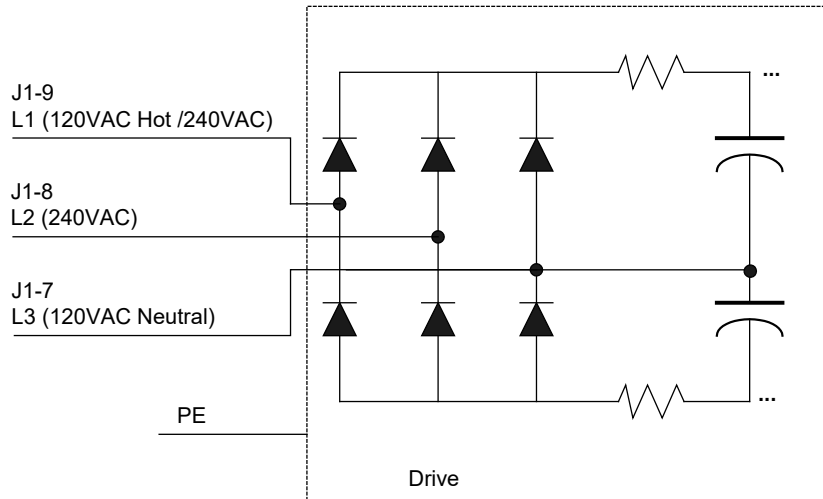

Figure 1. Main Power Line Connection of the S2xx50 AC Input Voltage Doubler Drive

In the S2xx50 AC input voltage doubler drives, AC line L3 is shorted to the center point of the two series connected bus capacitors as shown in Figure 1. For voltage doubling, connect single-phase 120 VAC to J1-9 L1 and J1-7 L3. On the same unit, connecting 240 VAC to J1-9 L1 and J1-8 L2 gives standard single-phase full wave rectification. In both cases, the result is a 320 VDC nominal bus voltage.

Three-phase AC line operation is not possible with the S2xx050 AC input voltage doubler models. In fact, connection to a three-phase source will damage the drive. Please use the standard S2xx60 AC input version of the product.

When doubling a 120 VAC line, the drive continuous power specification is derated to about 70% of standard single-phase ratings. The following table gives the power specifications for 120 VAC voltage doubled operation. Refer to the ratings in Voltage Sag Standard for 240 VAC single-phase operation.



## F.1 S2XX50 AC LINE VOLTAGE DOUBLING DRIVE POWER SPECIFICATIONS

120 VAC Voltage Doubling	S20250	S20350
Peak Output Current (ARMS) 0 to 40°C Ambient	4.5	9.0
Minimum Peak Current Time Starting from 0 Amps	3.0	3.0
Cont. Output Current (ARMS) 0 to 40°C Ambient	1.5	3.0
Continuous Output Power (Watts)	350	750
Peak Output Power (Watts)	1200	2400
RMS Line Current at Continuous Output Power (RMS)	5	10
Fusing – Line Inputs	FRN-R-10	FRN-R-20



*S200 units with the voltage doubling option manufactured before June 2004 have the function of L1 and L3 reversed. Using 240 VAC on old voltage doubled units with this new documentation will lead to catastrophic failure of the drive.*

### Requirements for Safe Operation of the Drive

It is the machine builder's responsibility.

## APPENDIX G – REGULATORY INFORMATION

### G.1 CONFORMANCE REQUIREMENTS

The equipment described herein has been developed, produced, tested and documented in accordance with the corresponding standards. During use conforming with requirements, the equipment is not dangerous for people or equipment. Use conforming with requirements means that the safety recommendations and warnings detailed in this manual are complied with and that the applicable regulations for safety (machine directives, etc.) and noise suppression (EMC Directives) are observed while operating the drive. At the end of its lifetime, dispose of or recycle the drive according to the regulations applicable at that time.

### G.2 CE APPROVAL

The CE initials confirm that the S200 drives satisfy all requirements of CE Directives. However, the equipment is not ready to operate without additional installations (cable, motor, etc.). Thus, all necessary tests and measurements had to be made on a typical installation. The test installation with all peripheral devices, as well as the test results and measurements are recorded in detail in documentation that is available from the manufacturer on request.

### G.2 CE EMC COMPLIANCE

*If the connection method on your machine is different from the ones pictured in this manual, or in the event of use of components other than those specified, adherence to CE interference limit values cannot be guaranteed.*



NOTE

*The machine builder should incorporate good EMC installation and wiring practices in the machine design. Some machine designs require more EMC consideration than others. For example, a multi-axis machine generates more noise than a single-axis machine. Therefore, multi-axis machines may require additional noise reduction techniques, such as a metal enclosure or clamping of cables' shields to an RF ground.*

## G.2.1. CE Test Setup

### AC MODELS S2XX6X-XXX, S2XX5X-XXX

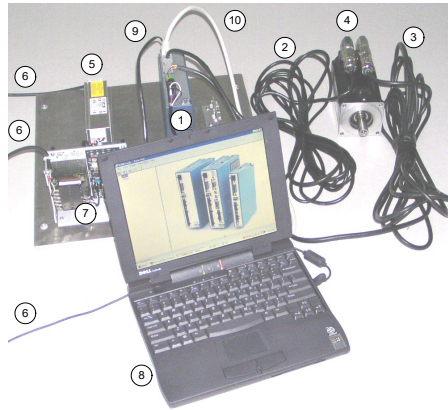

Example of Test Setup

- 1) **S200 AC DRIVE:** S20360-VTS
  - 2) **MOTOR FEEDBACK CABLE:** CF-DA0111N-05-0 (CF-DA0111N-50-0 for conducted emissions)
  - 3) **MOTOR POWER CABLE:** CP-102AAAN-05-0 (CP-102AAAN-50-0 for conducted emissions)
  - 4) **MOTOR:** KOLLMORGEN AKM43K-ANCNC-00
  - 5) **LINE FILTER:** MTE RF30006-4 (see \* below)
  - 6) CORDS FOR AC MAINS CONNECTION
  - 7) 5V POWER SUPPLY FOR ENABLE OPTO
  - 8) PERSONAL COMPUTER
  - 9) SERIAL CABLE (for setup and diagnostics)
  - 10) SHIELDED I/O CABLE WITH DSUB SHELL GROUNDED AT EACH END
- \* (cable between filter and drive shielded with shield tied to PE with a 360 degree termination at each end of the cable)

## G.2.2 CE Test Setup

(DC MODELS S2XX3X-XXX)

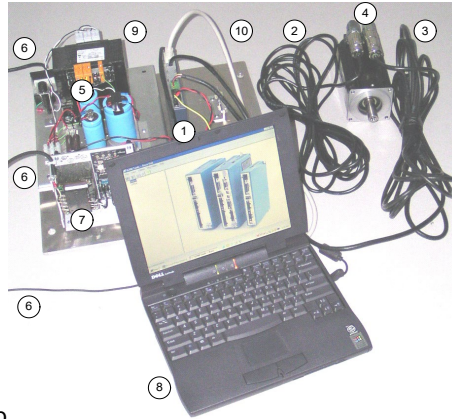

Example of Test Setup

- 1) **S200 DC DRIVE:** S20630-VTS
- 2) **MOTOR FEEDBACK CABLE:** CF-DA0111N-05-0 (CF-DA0111N-50-0 for conducted emissions)
- 3) **MOTOR POWER CABLE:** CP-102AAAN-05-0 (CP-102AAAN-50-0 for conducted emissions)
- 4) **MOTOR:** KOLLMORGEN AKM43K-ANCNC-00
- 5) SAFETY ISOLATED DC BUS POWER SUPPLY
- 6) CORDS FOR AC MAINS CONNECTION
- 7) 5V POWER SUPPLY FOR ENABLE OPTO
- 8) PERSONAL COMPUTER
- 9) SERIAL CABLE (for setup and diagnostics)
- 10) SHIELDED I/O CABLE WITH DSUB SHELL GROUNDED AT EACH END

## G.2.3 Declaration of Conformity

In our Declaration of Conformity, we affirm our compliance with Directive 73/23/EEC (Low voltage Directive) and with Directive 89/336/EEC (EMC Directive).

EMC testing was done according to EN61800-3: (Emission limits according to chapter 6.3.1 of that regulation, First environment / restricted distribution) for the following drives:

- S20260-VTS, S20360-VTS, S20330-VTS, S20630-VTS,  
S20260-SRS, S20360-SRS, S20330-SRS, S20630-  
SRS, S20260-SDS, S20360-SDS, S20330-SDS,  
S20630-SDS, S20660-VTS, S20660-SRS, S20660-  
SDS, S21260-VTS, S21260-SRS, S21260-SDS  
S22460-VTS, S22460-SRS, S22460-SDS

During assembly of our product in a machine, startup (that is, normal operation) is prohibited until the end-product complies with Directive 89/392/EEC (Machine Directive) and directive 89/336/EEC (EMC Directive).

The machine manufacturer must prove that the complete system conforms with all relevant European Directives.

Drive conformance to specified standards is certified by the Declaration of Conformity in this manual.

## CE Declaration of Conformity

### We, the company

Kollmorgen  
201 West Rock Road  
Radford, VA 24141

Hereby in sole responsibility declare the conformity of the product series

### Kollmorgen Motion S200 Digital Servo Drives

Which includes the models:

S20330-VTS, S20630-VTS, S20260-VTS, S20250-VTS, S20360-VTS, S20350-VTS, S20660-VTS,  
S21260-VTS, S22460-VTS,  
S20330-SRS, S20630-SRS, S20260-SRS, S20250-SRS, S20360-SRS, S20350-SRS, S20660-SRS,  
S21260-SRS, S22460-SRS  
S20330-SDS, S20630-SDS, S20260-SDS, S20250-SDS, S20360-SDS, S20350-SDS, S20660-SDS,  
S21260-SDS, S22460-SDS

### With the following standards:

- **Low Voltage Directive 73/23/EEC**
- **EMC Directive 89/336/EEC**

### European Harmonized, National, & International Standards

EN 50178

EN 61800-3

*Product has been reviewed, tested, and found to be in conformity with the above standards. Product has also been reviewed per UL508C, IEC 721-3-2, and IEC 721-3-3.*

**For recommended configurations see the installation manual or instructions (M-SM-200-01).**

**This Declaration does not contain any assurance of properties in the meaning of product liability.**

**The notes on safety and protection in the operating instruction must always be observed.**

**The above-mentioned company has the following technical documentation for examination:**

- **Proper operating instruction**
- **Diagrams**
- **Other technical documentation (for EU authority only)**
- **Technical construction file (for EU authority only)**

Legally binding

Signature



### **G.3      *INSTALLATION AND COMMISSIONING***

Installation and wiring of the drive must be completed only by qualified personnel having a basic knowledge of electronics, installation of electronic and mechanical components, and all applicable wiring regulations.

Only qualified personnel having broad knowledge of electronics and motion control technology are to commission the machine utilizing the drives.

This manual should be read in its entirety. This appendix contains important regulatory information not necessarily covered in earlier chapters. The material in this section should be taken into consideration to ensure compliance with applicable regulatory requirements. This section alone does not contain all the information needed to install and operate an S200 drive. General information on installation and wiring are explained in detail in previous sections.

### **G.4      *SAFETY REQUIREMENTS***

As the user or person applying this unit, you are responsible for determining the suitability of this product for the application. In no event will Kollmorgen be responsible or liable for indirect or consequential damage resulting from the misuse of this product.

Read this manual completely to effectively and safely operate the S200.

### **G.5      *EUROPEAN COMPLIANCE***

In Germany, these include:

- DIN VDE 0100 (instructions for setting up power installations with rated voltages below 1000 V).
- DIN - EN 60204 - Part 1, (VDE 0113, part 1) instructions relative to electric equipment in machines for industrial use.
- DIN EN 50178, (VDE 0160) instructions relative to electronic equipment for use in power installations.

## **G.6 LOW VOLTAGE DIRECTIVE AND EN50178**

To ensure compliance with the Low Voltage Directive and EN50178, following these requirements:

- Electronic drives contain electrostatic sensitive devices, that can be damaged when handled improperly. Qualified personnel must follow ESD protection measures. For example: wear grounded heel and wrist straps when contacting drive.
- The climatic conditions shall be in accordance with EN 50178 climatic class: Type B, temperature and relative humidity: Class 3K3.
- The drives shall be installed in an environment of Pollution Degree 2 or better.
- The S200 drives are not considered portable and are to be mounted in the intended manner in a motor/control cabinet having adequate strength and thickness with acceptable spacing for the end product classification accessible by qualified personnel only. The enclosure/cabinet shall meet at least the requirements of Protective Type IP2X according to 5.1 of EN 60529. If the top surface of the enclosure/cabinet is easily accessible it shall meet at least the requirements of the Protective Type IP4X.
- Care shall be taken to ensure that the larger device or enclosure that accommodates the built-in device provides protection against direct contact.
- The S200 drives may be erected in closed electrical operating areas if a protection against direct contact is available or assigned for by means of obstacles and/or a distance according to IEC 364-4-412.3 and IEC 364-4-412.4.
- Follow IEC 536-2 and IEC 1140 for installation protection against electric shock.
- Installation shall be performed in accordance with local electric codes, local accident prevention rules, EN 50178 and EN 61800-3.
- Never connect or disconnect any drive connectors or terminals while the power is switched on.
- Due to high leakage current, permanently install this drive (hard wired or fixed type). The PE connection shall be made by two separate protective conductors satisfying the requirements for protective conductors as given in 543 of HD 384.5.54 S1 between the earth ground and the PE terminal(s) on the drive, or by a protective conductor having a cross section of at least 10 mm<sup>2</sup> Cu. The S200 drives are designed to Protective Class I.
- The discharge time for the bus capacitors may be as long as 5 minutes. After disconnecting the drive from the ac mains be sure to wait 5 minutes before removing the drive's cover and exposing live parts.
- The finished installation shall comply with the requirements of the IEC 364-4-41 series of standards.
- The cables and leads (except the protective conductors) used in the erection of the S200 in an installation which are accessible for contact without opening or removing a barrier or are laid on extraneous conductive parts shall have double or reinforced insulation between the core and the surface or shall be surrounded by a metal screen having a satisfactory current-carrying capacity in the event of a short-circuit between the core and the screen.
- When installing the S200 into its operating location, it shall be ensured that any existing protective separation according to 5.2.18 of EN50178 is maintained throughout the entire length of the circuit in question. In installations the compliance for of the measures for protective separation shall be checked by visual inspection.
- Refer to Sections 1 and 4 of this manual for external fusing information.
- Motor cable shield must be connected to protective earth.
- During periods of extreme regeneration or excessively high input voltage the temperature of the regen resistor may exceed 70 °C.
- When using an external regen resistor, if regen cabling is accessible during normal machine operation, regen resistor cable should be rated at 300 Vac and shielded with shield connected to PE.

- Consult the factory before using this product on a circuit protected by a residual-current-operated protective device (RCD).
- All covers shall be closed during operation.
- The S200 drives should be used within their specified ratings.

## **G.7 UL AND cUL CONFORMANCE**

The S200 drives are UL and cUL Recognized to UL 508C under UL File number E137798. Consider the following points to ensure that final installation meets UL requirements:

- The drive should be used within its specified ratings.
- The drive should be mounted in the intended manner in an enclosure having adequate strength and thickness with acceptable spacing for the end product classification.
- The spacing from the exposed live-metal parts to the enclosure wall should be in accordance with the requirements for the overall equipment.
- These drives shall be used in a pollution degree 2 environment in order to comply with the spacing requirements of UL 840 and UL 508C.
- The UL temperature tests were done with a metal heat plate with overall dimensions, 6 in x 12 in x 1/8 in. The machine builder is responsible for ensuring adequate heat sinking capability in the final installation.
- The thermal protective device(s) provided integral to the motor drives were not evaluated by UL.
- The terminals are suitable for factory wiring only.
- These motor drives have not been evaluated to provide solid-state overload or over speed protection.
- The DC models were evaluated by UL for use with an isolated power supply rated no more than 150 V open circuit secondary voltage and 10 kVA secondary power. This combination shall be maintained to satisfy UL requirements.



## G.8 ADDITIONAL SAFETY PRECAUTIONS

### Motor Case Grounding

Insure that the motor's case is connected to PE ground. The fourth wire in the motor cable connecting J2-1 or TB1-1 to the motor case accomplishes this.



*If the motor is not properly grounded, dangerous voltages can be present on the motor case due to capacitive coupling between the motor windings and case.*

### Requirements for Safe Operation of the Drive

It is the machine builder's responsibility to insure that the complete machine complies with the Machine Directive (EN60204).

The following requirements relate directly to the servo controller:

#### 1. Emergency Stop



*If personal injury can result from motor motion, the user must provide an external hardwired emergency stop circuit outside the drive. This circuit must simultaneously remove power from the drive's motor power terminal J2-2, J2-3, and J2-4 or TB1-2, TB1-3, and TB1-4 and disable the drive (by open circuiting the connection to J4 pin 2).*



*The motor will coast under this condition with no braking torque.*



*If braking torque is required to quickly stop the motor, a dynamic brake can be added that loads the motor's windings resistively. The motor should not be loaded until the servo drive is disabled. The holding brake, optional on Kollmorgen motors, is not intended to stop a spinning motor. It is designed to prevent a stopped motor from rotating due to an applied torque.*

#### 2. Avoid Unexpected Motion



*Always remove power from J1 or TB1, J1 and wait 5 minutes before working on the machine or working anywhere where injury can occur due to machine motion.*

#### 3. Avoid Electrical Shock



- *Never power the servo drive with the cover removed or with anything attached to circuitry inside the cover.*
- *If the drive must be removed from the cabinet, wait at least five minutes after turning off power before removing any cables from the drive or removing the drive from the mounting panel.*
- *Never connect or disconnect any wiring to the drive while power is applied. Always power down and wait five minutes before connecting or disconnecting any wires to the terminals.*

#### 4. Avoid Burns



*The temperature of the drive's heat sink and housing as well as an external regen resistor may exceed 60° C. Therefore, there is a danger of severe burns if these regions are touched.*

#### 5. Prevent Damage to the Drive

Follow these guidelines to prevent damage to the servo drive during operation:

- *Never plug or unplug connectors with power applied.*
- *Never connect or disconnect any wires to terminals with power applied.*
- *If the drive indicates a fault condition, find the cause of the fault and fix it prior to resetting the fault or power-cycling the drive.*

## G.9 EMC COMPLIANCE WITH EN61800-3

### Use in a Domestic Environment



*The products covered in this manual are of the restricted sales distribution class according to IEC 61800-3. In a domestic environment this product may cause radio interference in which case the user may be required to take adequate measures.*



*Because applications differ, it is impossible for the drive manufacturer to guarantee machine EMC compliance. In some applications, it may be necessary for the machine builder to incorporate more EMC mitigation techniques than Kollmorgen had to use in the EMC test setups.*

### General Suggestions to Improve Machine EMC Performance

- Use Kollmorgen cables – Kollmorgen cables have been designed with EMC considerations in mind. Because subtle differences in cable construction can cause dramatic changes in EMC performance use of Kollmorgen's motor power and feedback cables is recommended.
- When joining or splicing sections of cable, be sure to maintain the integrity of the cable shield along the entire length of the finished cable.
- Separate cables according to type - AC Mains input, motor power and signal cables should be separated from each other by at least 100 mm (4 in) to avoid cross coupling between them. If cables of different types have to cross, they should do so at a 90° angle.
- Route wiring close to machine frame - It is a good practice to run wires along the machine frame (local ground) whenever practical, this couples some high frequency noise/signals that could otherwise be troublesome directly to the local ground.
- Remove paint from all drive, filter, and cable clamp mounting locations.
- Add clamp-on ferrites to cables – Adding clamp-on ferrites to noisy cables can reduce emissions by absorbing RF energy before it is radiated.
- Use the appropriate line filter – A line filter is required for CE applications, more information on line filter selection can be found in D.10
- Add a balun to the motor power cable – adding a balun in series with the U, V and W phases of the motor power cable can attenuate both conducted and radiated emissions.
- Ensure that cables shields have a good RF ground – more information on this can be found in D.10.

## G.10 AC MAINS CONDUCTED EMISSIONS

### Line Filter

To meet the CE-conducted EMC requirements, an external line filter (in series with the AC mains) is necessary. It is the responsibility of the machine builder to choose filter(s) appropriate for the application. Kollmorgen is willing to assist in this choice. Often, the decision is made to filter the machine as a whole instead of filtering the individual drives.

Mount the line filter as close as possible to the point where incoming power enters the machine/cabinet. Locate the drive(s) as close as possible to the line filter. To provide maximum high frequency filtering, remove any paint from between the filter, the drive and the conductive surface, ground plane to which they are bonded. For maximum benefit, separate input wiring to the line filter and output wiring from the line filter from each other.

During CE testing, multiple line filters were qualified for use with 50 m motor and feedback cables to represent worse-case, conducted emissions compliance. The below lists filters used during CE testing. Match filter rating to drive input ac ratings for proper combinations.

Corcom 6EQ1 (single phase)

Corcom 36FCD10 (three phase)

MTE RF30006-4 (three phase)

Schaffner FN258-7, FN258-16, FN258-30, FN3258-16, FN3258-30 (three phase)

Information on these and other filters can be found at:

Corcom, Inc.	MTE Corporation	Schaffner
USA 1-800-468-2023		
<b>or</b>	USA 1-800-455-4MTE	USA 1-800367-5566
847-680-7400		
Germany 49-89-857920	International 1-262-253-8200	Switzerland 41-32-6816-626
<a href="http://www.cor.com">http://www.cor.com</a>	<a href="http://www.mtecorp.com">http://www.mtecorp.com</a>	<a href="http://www.schaffner.com">http://www.schaffner.com</a>



**NOTE**

For complete instructions on wiring an AC version S200 drive refer to AC Input Drive Wiring, of this manual. For complete instructions on wiring a DC version S200 drive refer to the DC Input Drive Wiring.

### Motor Power Cable Filtering

In typical applications, the S200 drives do not require additional filtering in the motor leads. Machines with many drives and long motor power cables may require an external balun in series with the power motor power cable to reduce the machine's conducted emissions. Additional information can be found in Pacific Scientific Application Notes 106 (**Reducing Motor Drive Line Noise**) and 107 (**Reducing Motor Drive Radiated Emissions**).



**NOTE**

**Balun PN: 104-090003-01**

**Current Rating** 60 A sinewave pk (42 ARMS) 5 sec  
20 A sinewave pk (14 ARMS) cont

**Inductance** 340  $\mu$ h nominal

**Energy Rating** 7,200  $\mu$ J nominal

**Resistance** 0.021  $\Omega$  nominal

**Gap** 10 mil

### Ground Cable Shields

The Motor Power (J2 or TB1), Feedback (J3), Command I/O (J4), and Serial Port (J5) cables must be shielded and the shields should be connected to PE. The safety PE connection can be made through connector pin or shell.



**All cables used with the S200 drives should be shielded with the shields connected to PE. Dangerous voltages, resulting from cable capacitance, exist on some cable shields if the shields are not connected to PE ground.**

#### Avoid Crosstalk



**To avoid the risk of crosstalk, keep the motor and feedback cables away from sensitive signal cables (i.e., telephone and intercommunication lines). Shield all cables used with the S200 drives with the shields connected to PE.**

EMC testing was performed using a single drive with standard wiring. When a machine incorporates several drives or is designed for use in an environment requiring very low emissions, additional steps may be necessary to reduce the overall machine emissions and/or susceptibility. High frequency grounding of cable shields may help reduce radiated and conducted emissions as well as protect against susceptibility to external and self-generated noise.

#### High Frequency Grounding of Cable Shields

- When a cable with a separate inner foil shield and outer braided shield is used, EMC performance may be improved by connecting the foil shield to the PE location on the connector and removing about 10 mm (0.5 in) of the outer cable jacket close to the drive [within 0.6 m (2 ft) of the drive] to expose the braided shield and clamping the outer braided shield to the ground plane with a 360°-type clamp.
- If a ground plane is available at the motor end of these cables, similar use of a conductive clamp at that end to connect the shield to the ground plane may help as well. Clamping the cable shields to PE typically reduces the level of emissions and increases the level of immunity to interference.



#### Example of 360° clamping of cable shields



## G.11 REGEN RESISTOR

### Regen Wiring (AC drives)

For complete instructions pertaining to an external regen resistor with an AC input drive, refer to Base AC Drive Wiring. In addition to the information in that section, users installing drives for use in a CE installation should use an appropriately-grounded, shielded regen cable to reduce overall system emissions.

#### Accessible Regen Cables



**When using an external regen resistor, if regen cabling is accessible during normal machine operation, the cable should be a shielded cable rated at 450 VDC with the shield connected to PE.**

#### High Frequency Grounding of Regen Cable Shield



**When using a regen resistor in a CE installation, the cable should be appropriately rated and have a braided shield connected to PE for safety, and clamped to the ground plane with a 360° clamp for EMC purposes**

## **G.12 ADDITIONAL EMC INFORMATION SOURCES**

Additional information on EMC performance and noise reduction techniques can be found on the Kollmorgen website ([www.Kollmorgen.com](http://www.Kollmorgen.com)):

Kollmorgen Application Note *EMI Noise Checklist*

Pacific Scientific Application Note 106 - *Reducing Motor Drive Line Noise*

Pacific Scientific Application Note 107 - *Reducing Motor Drive Radiated Emissions*

## **G.13 CUSTOMER SUPPORT**

Kollmorgen products are available world-wide through an extensive authorized distributor network. These distributors offer literature, technical assistance, and a wide range of models off the shelf for the fastest possible delivery.

Kollmorgen sales and application engineers are conveniently located to provide prompt attention to customer needs world wide. Call the nearest office for ordering and application information and assistance or for the address of the closest authorized distributor. If you do not know who your sales representative is, contact us at:

### **Europe**

#### **Kollmorgen Customer Service Europe**

Phone: +49(0)203 9979 0

Fax: +49(0)203 9979 155

Email: [sales.europe@kollmorgen.com](mailto:sales.europe@kollmorgen.com)

Website: [www.Kollmorgen.com](http://www.Kollmorgen.com)

### **North America**

#### **Kollmorgen Customer Service North America**

Phone: 1-540-633-3545

Fax: 1-540-639-4162

Email: [support@Kollmorgen.com](mailto:support@Kollmorgen.com)

Website: [www.Kollmorgen.com](http://www.Kollmorgen.com)

# APPENDIX H – HARDWARE AND REGULATORY UPDATE

## H.1 INTRODUCTION

Since the introduction of the S200 servo drive product family a few key electronic components have gone obsolete. Keeping form, fit, and function exactly equivalent products in production meant making power board hardware updates. Given that updates were being done, components that had a small predicted remaining life were also proactively updated.

These updates affect all S200 base units. The SynqNet (-SRS), CANOpen (-CNS), and the DeviceNet (-DNS) option cards have not been changed. Since the option card hardware is not changing, then the option card FW is not changing either. Only power board circuitry and power board FPGA Control Logic are being updated.

These hardware updates started shipping in some model numbers late in calendar 2021 and the last of the S200 models were updated by the end of 2022. Looking at the product label you can check the HW revision. Revision “C” is the updated hardware that is documented in this Appendix.

<b>HW Rev A</b>	Original units pre-RoHS with Control Logic 1.xxx and 2.xxx prior to 2006
<b>HW Rev B</b>	RoHS units with Control Logic 3.xx (latest 3.2M) from 2006 through 2022
<b>HW Rev C</b>	RoHS updated hardware units with Control Logic 4.xx from 2021 onward

While bringing these form, fit, and functionally equivalent replacement products to market there are 2 areas of enhancement/changes to be aware of.

### 1. Regulatory Certification Changes:

- a. UL certification had to be changed. When the S200 originally entered the market the UL 508C standard governed drive products like the S200. On February of 2020 UL obsoleted the UL 508C standard and replaced it with UL 61800-5-1 that is modeled after the EN 61800-5-1 EU specification to better world-wide harmonize standards. As such, updated S200 drives are certified to UL 61800-5-1. HW Rev C units will change from cURus marked recognized component to be cULus marked listed component. cULus also covers Canadian applications.
- b. For EU market approvals there has also been evolution since original product certifications in the 2004 time frame. The old HW had EN 50178 and the HW Rev C has EN 61800-5-1 for compliance certification for the Low Voltage Directive.

### 2. Functionality Enhancements:

- a. In the original S200 family there were a few customized units with different base unit Control Logic to give a couple of additional features. For these updated products the updated features are being integrated in the standard base unit Control Logic. Access to these new functions is by new NV setup parameters when using the updated S200Tool GUI setup software available on [www.kollmorgen.com](http://www.kollmorgen.com).
- b. Bus voltage sensing in the S20260, S20360, S20660, and S21260 originally used a resistive differential amplifier resulting in very low, but not zero, leakage from the ac line to the control circuitry ground. The updated versions of these four drive models were improved to work like the S22460 and have full galvanic isolation from the ac line to the control circuitry.
- c. Enhanced PWM frequencies from 8.2 kHz to 10.4 kHz for lower audible noise and tighter current control on S20660 and S21260 products.

## **H.2 BASE UNIT FPGA CONTROL LOGIC UPDATE**

One of the proactive updates was changing the base unit control FPGA to a newer part. The newer part runs 95% the exact same Control Logic design that the previous version did. However, a small amount of the logic design had to be updated to accommodate the new FPGA. In addition, a few previously custom Control Logic options were merged into the standard product. Lastly, the Control Logic download file internal file format for the new part is different. Consequences of this FPGA update are:

- New Control Logic versions 4.xxx are required for the Rev C updated units
  - Old power board Control Logic versions (3.2M and prior) are not compatible with updated Rev C S200 power hardware
- Default 4.0xx Control Logic for Rev C HW provides functionally identical operation to Rev B HW with 3.2M Control Logic (latest version for Rev B HW).
- 4.xx Control Logic adds two new options that were previously customized Control Logic versions:
  - Filter type: ARfx default and now new BiQuad option
  - Feedback type: SFD default and now new options for ENDAT2.2, BiSS B, BiSS C, and Tamagawa all digital feedback devices
- New S200 Tools 2.8.0 user GUI or later is required to change new parameters or download Control Logic updates to updated Rev C HW. This new version 2.09.0 or newer also fully supports prior Control Logic versions and will work fine with Rev B or even Rev A HW for all the old functionality and for downloading older Control Logic files to those older HW's.

Because previously customized versions are now integrated in the standard unit some customers previously ordering customized versions will need to order the HW Rev C catalog standard version and use the new setup parameters.

Please refer to figure H.1 for a flow chart to determine if this update affects your application.

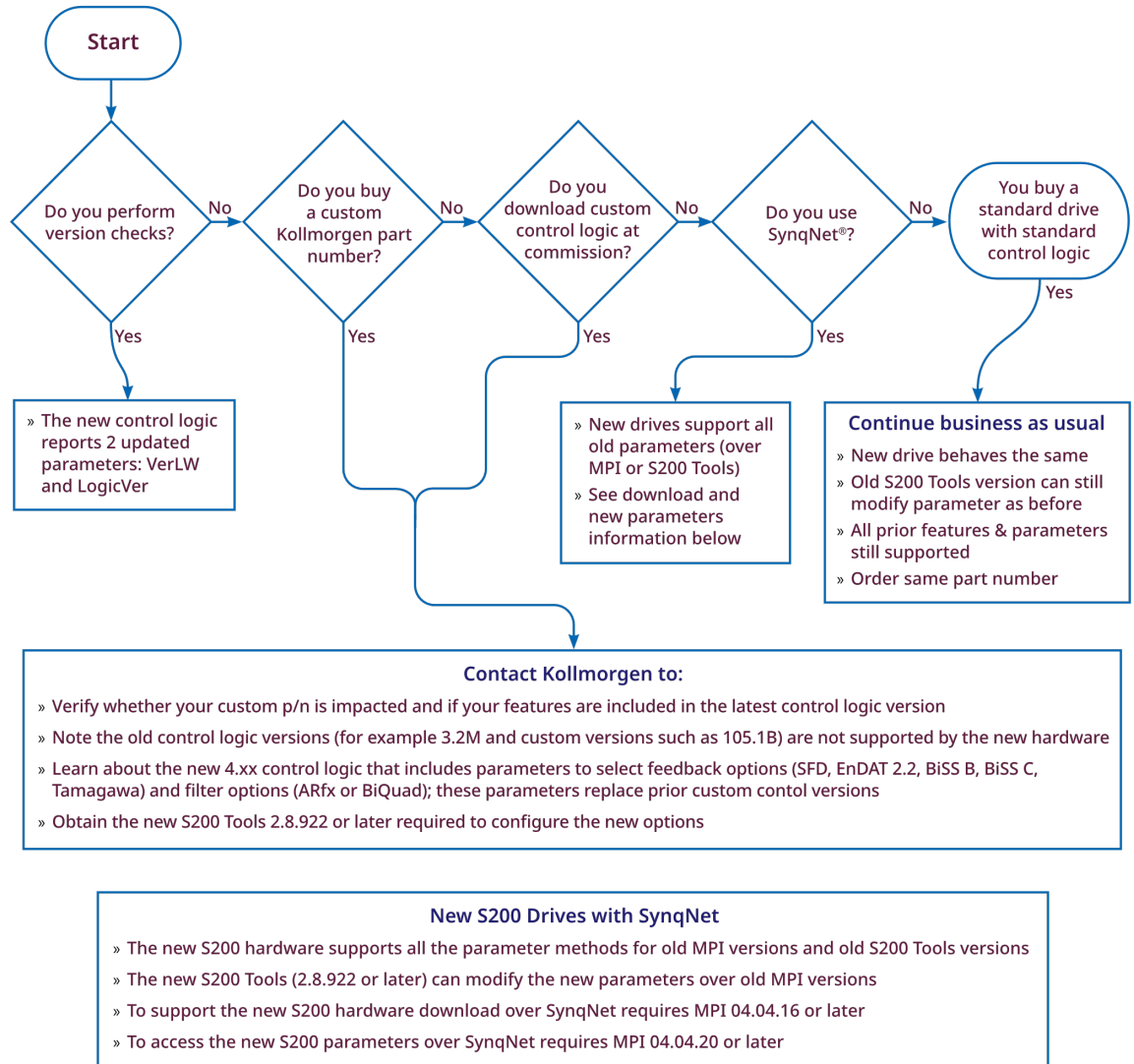
**Figure H.1: Decision Tree – Does this HW update cause any customer change?**



## H.3 FUNCTIONALITY ENHANCEMENTS

By default, the new Control Logic 4.xx features are identical to the latest Control Logic for the previous HW which was version 3.2M. In addition, the 4.xx Control Logic adds two new parameters. These parameters allow a single 4.xx Control Logic to replace 3.2M and multiple special versions of the older Control Logic. Note a new version of S200 Tools (2.09.xxx or later) is required to access these parameters. The prior versions of S200 Tools are compatible with Control Logic 4.xx except:

- No access to the new parameters
- No ability to download Control Logic updates.
- Will not properly reset to factory defaults for enhanced PWM frequency.

It is recommended that **all users** update to the latest S200Tools GUI software for complete support of all versions of S200 drives. Download from the Kollmorgen website.

For S200 drives with SynqNet option cards, access to the new parameters requires MPI version 04.04.16 or later.

### H.3.1 NEW PARAMETERS FOR CONTROL LOGIC 4.XX

Control Logic 4.xx adds two new parameters: **FilterType** and **FbType**. These parameters are described below. **FBDivisor** is also documented here even though it is not new. It was previously only used on customized versions.

<b>FilterType</b>	<b>ARfx or BiQuad</b>	<b>ARfx Default</b>
This parameter selects between the velocity loop forward path default single pole Anti-Resonance (ARfx) filters, and second order full BiQuad filters. Set the value, NVsave, and power cycle the drive to take effect. This parameter is available in SynqNet with MPI 04.04.16 or later.		

**WARNING:** do not change **FilterType** while the drive is enabled. Unexpected transient motion could occur.

3 = ARfx (default)  
 2 = BiQuad  
 1-0 = reserved

<b>FbType</b>	<b>SFD, BiSS B, BiSS C, EnDat 2.2, or Tamagawa</b>	<b>SFD Default</b>
This parameter selects between the different feedback options for the S200 base unit feedback connector J3. Note for feedback types other than SFD/Hall, switch S2-3 must be UP/Open, also SelSFDParam must be set to Drive. Set the value, NVsave, and power cycle the drive to take effect. This parameter is available in SynqNet with MPI 04.04.16 or later.		

**WARNING:** do not change **FbType** while the drive is enabled. Drive state is not fully defined while changing feedback devices.

15 = SFD or Six-Step Hall Feedback (default)  
 DIP switch S2-1 Down/Closed selects SFD (default)  
 DIP switch S2-1 Up/Open selects Six-Step (Hall)

See also parameter **CommMode**

14 = BiSS B Feedback (digital only, bidirectional, aka Hengstler)

13 = BiSS C Feedback (digital only, unidirectional, aka Renishaw)

12 = EnDat 2.2 Feedback (digital only)

11 = Tamagawa Feedback

10-0 = reserved

**FBDivisor**                      **1 to 2,147,483,647**

This parameter is the divisor used to scale the EnDat 2.2 and BiSS Mode C encoder absolute counts. This parameter is not used for other **FbType**. This parameter is set automatically by the drive for rotary encoders for EnDat 2.2 feedback and must be manually set for BiSS Mod C feedback.

**FBDivisor** =  $\{ 2^{(32 - \text{number of position bits})} * (\text{motor pole Pitch}) \} / (\text{encoder resolution})$

Example Linear Axis: 23 bit encoder, motor pole pitch of 32 mm and encoder resolution of 5um

**FBDivisor** =  $\{ 2^{(32-23)} * 32e-3 \} / 5e-6 = 3276800$

## H.3.2 PROCEDURE TO CHANGE FBTYPE

The proper sequence to change **FbType** is:

1. Disable the drive
2. Set **SelSfdParam** = Drive. S200 Tools may return an error message if an SFD drive was not attached at power-on; please ignore this error message.
3. For feedback types BiSS B, BiSS C, EnDat 2.2, or Tamagawa, set the switch S2-3 to Up/Open. For SFD/Hall set S2-3 Down/Closed

Set S2-2, S2-4 to Down/Closed.

4. Attach the new feedback device
5. Set **FbType** to the new feedback type
6. Save to NV
7. Power-cycle the S200 drive. At this point the new feedback selection will take effect, position data will be valid, and no faults should occur.
8. Confirm that position changes with motor rotation, the direction is correct (positive = clockwise facing into the motor spindle) and that position scales correctly per rev (**PosFB** rolls over from 65536 to 0).
9. If this is not a Kollmorgen motor, it may be necessary to set **CommOff** to correct for motor phase wiring and/or swap wiring to get everything to work. See Appendix D – Process to Setup Non-Kollmorgen Motors for more information.
10. If this is not an SFD motor, please set **DPoles**, **I2Tf0**, **I2TTrip**, **IlmtPlus**, **IlmtMinus**, **KIP**, and **KVP** as required.

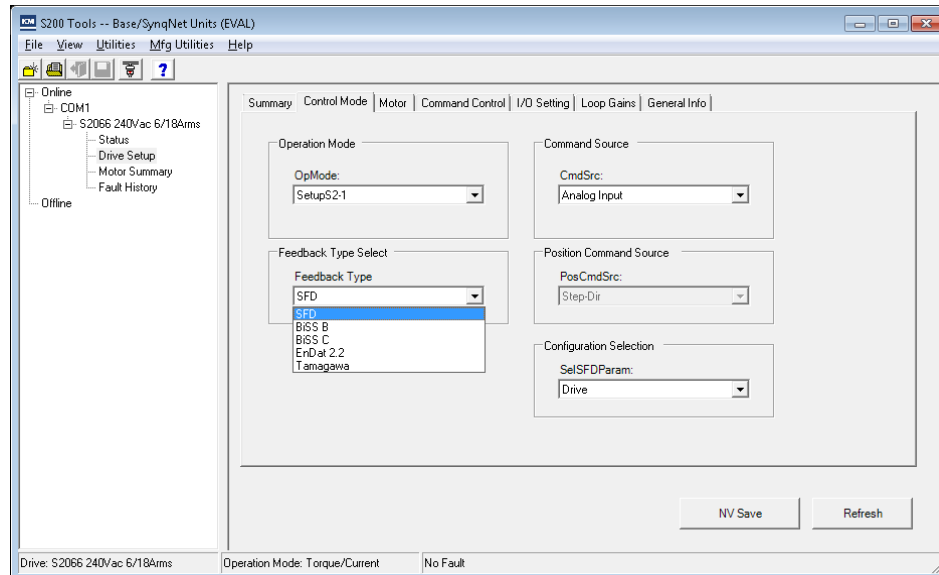

**SFD Details:** The **SeISFDParam** controls the reading of motor data for certain parameters (see **SeISFDParam** documentation for details). **SeISFDParam** is forced to Drive until the S200 is power-cycled with **FbType** = SFD and SFD motor attached. S200 Tools may report a parameter error until the **FbType** matches the motor and the S200 is power-cycled (just ignore the error and power-cycle the drive to continue). Note **FBDivisor** is NOT used for SFD feedback.

**BiSS B details:** This is a bi-directional BiSS mode. Note **FBDivisor** is NOT used for BiSS B feedback.

*Fault Codes:* BiSS B errors are mapped to standard drive SFD fault codes. Use the following information to interpret S200 GUI fault information:

BiSS error	SFD Error
BiSS configuration error	SFD configuration error
BiSS transfer timeout	SFD transfer timeout

BiSS configuration errors are:

- 1) device not present or non-functional
- 2) BiSS Mode B command set not supported
- 3) Incremental encoders not supported
- 4) External Interface Box (EIB) type not supported
- 5) CRC errors

BiSS transfer timeout: Failed to complete data transfer within 62.5usecs.

**BiSS C details:** This is a uni-directional BiSS mode. Note **FBDivisor** MUST be manually set for BiSS C feedback. Contact the factory to adjust clock rate or the number of position bits.

*Fault Codes:* BiSS C errors are mapped to standard drive SFD fault codes. Use the following information to interpret S200 GUI fault information:

Fault Code	Blink Count	Status SFD	Status BiSS
01100	13	SFD Short	BiSS Short
01110	15	SFD Sensor Failure	BiSS Slave Sensor Failure
01111	16	SFD UART Error	BiSS CDS error
10000	17	SFD Comm Error	BiSS Comm Error

Bit	Extended fault	Definition (SFD)	Definition (BiSS)	Fault (code)
1	SFD UART parity error	The SFD UART received a parity error.	BiSS CDS error	SFD UART Error or BiSS CDS Error(16)
4	SFD Frame timeout	Indicates that more then 89.6 usecs has elapsed since last frame was received.	BiSS Sensor Frame Error	SFD Comm Error or BiSS Master Sensor Error(17)
5	SFD transfer incomplete	Indicates that a transfer started but did not complete in 18.4 usecs.	BiSS Sensor Timeout Error	
6	SFD CRC error(s)	In SFDSpan mode, this indicates that there was more then one CRC error over 256 transfers. If not in SFDSpan mode, any CRC error will fault.	BiSS Sensor CRC error	

BiSS transfer timeout: Failed to complete data transfer within 51.2 uSec.

EnDat 2.2 details: This is digital-only EnDat. The **FBDivisor** will be automatically set for rotary encoders, but the user must set **FBDivisor** manually for linear encoders. Please contact the factory if you need to read motor data over Endat.

*Fault Codes:* EnDat errors are mapped to standard drive SFD fault codes. Use the following information to interpret S200 GUI fault information:

EnDat error	SFD Error
EnDat configuration error	SFD configuration error
EnDat transfer timeout	SFD transfer timeout
EnDat flag 1	SFD UART parity error
EnDat flag 2	SFD UART overrun error

EnDat configuration errors are:

- 1) device not present or non-functional
- 2) EnDat 2.2 command set not supported by encoder
- 3) Incremental encoders not supported
- 4) External Interface Box (EIB) type not supported
- 5) CRC errors

EnDat transfer timeout: Failed to complete data transfer within 62.5 uSec.

Tamagawa details: This supports 17-bit/rev Tamagawa encoders with multi-turn data as per Tamagawa TS5667N420 specification. Note **FBDivisor** is NOT used for Tamagawa feedback. If Tamagawa feedback faults when first configured, please contact the factory for the manual method to change a hidden NV bit that enables multi-turn feedback. Also contact the factory if you need a procedure to send a special encoder reset command, or for encoder EEPROM access.

*Fault Codes:* Tamagawa errors are mapped to standard drive SFD fault codes. Use the following information to interpret S200 GUI fault information:

Tamagawa error	SFD error
Tamagawa sensor/command error	SFD sensor error
Tamagawa transfer timeout	SFD transfer timeout
Tamagawa transfer incomplete	SFD transfer incomplete
Tamagawa CRC error	SFD multiple CRC error
Tamagawa start transfer timeout	SFD UART parity error
Tamagawa UART over run error	SFD UART over run error
Tamagawa UART frame error	SFD UART frame error

Tamagawa sensor/command errors are:

- 1) Encoder counting error
- 2) Encoder multi-turn error
- 3) Battery error
- 4) Encoder received command parity error
- 5) Encoder received framing error.

Tamagawa transfer timeout: more then 89.6 usecs since last position transfer

Tamagawa transfer incomplete: A position transfer started, but did not complete.

Tamagawa CRC error: The calculated CRC did not match the received CRC.

Tamagawa start transfer timeout: A position transfer never started.

Tamagawa UART over run error: UART over run error.

Tamagawa UART frame error: UART frame error.

### H.3.3 J3 FEEDBACK PINOUTS

Pinouts for base unit feedback connector J3 are listed below for each **FbType**

Pin	SFD/Hall	EnDat 2.2	BiSS B, C	Tamagawa
J3-1	SFD +5 V (200 mA)	+5V	+5V	+5V
J3-2	SFD +5 RTN	+5 RTN	+5 RTN	+5 RTN
J3-3	SFD COM-	DATA-	SL-	SD-
J3-4	SFD COM+/CU	DATA+	SL+	SD+
J3-5	NC/CV	CLOCK-	MA-	
J3-6	NC/CW	CLOCK+	MA+	
x	x	x	x	BAT+
x	x	x	x	BAT-
Shell	Shield	Shield	Shield	Shield

**Notes:**

- 1) Use shielded cable, 22 AWG wires, twisted pair nominal 100 ohms (90 min to 150 max), up to 50 meters.
- 2) S200 provides regulated 5.1V +/-3.5% max 200mA encoder power at the drive.

## H.3.4 PROCEDURE TO CHANGE FILTERTYPE

The preferred sequence to change **FilterType** is:

1. Disable the drive
2. Set **FilterType** = BiQuad (ARfx is default)
3. Adjust filter constants as desired
4. Save to NV
5. Power-cycle the S200 drive. At this point the new filter values will be in effect

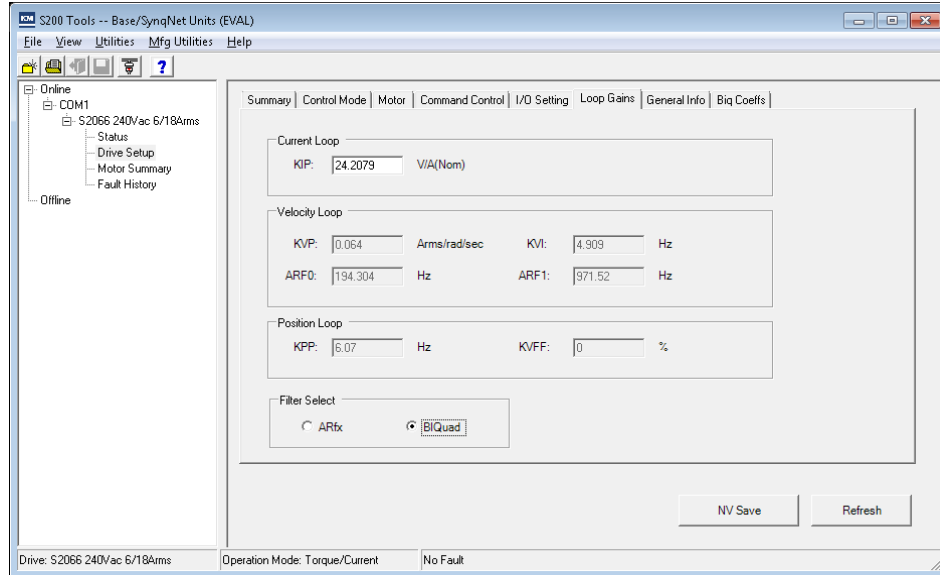

Note: after selecting the BiQuad filter option, the “Biq Coeffs” tab will be enabled:

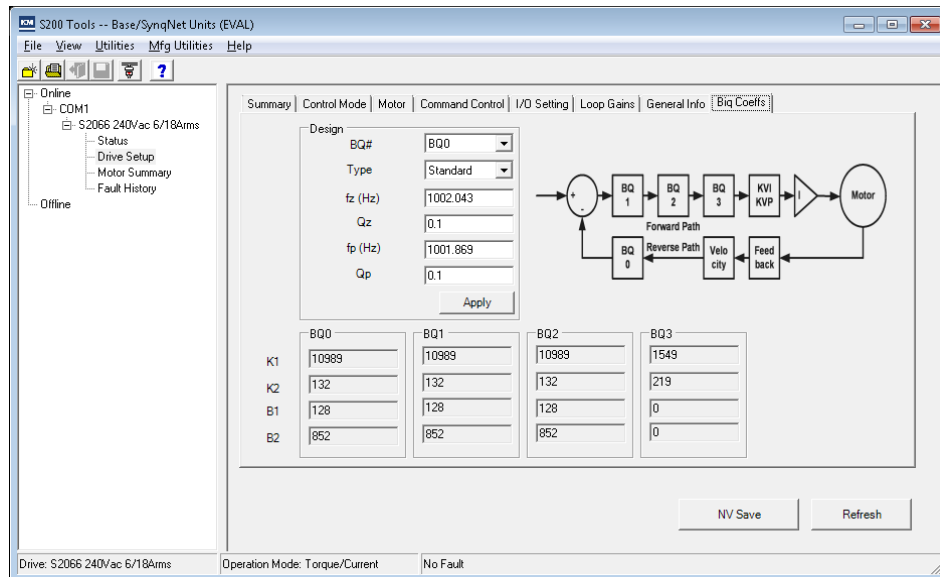

### H.3.5 BIQUAD FILTER FEATURE

The 4.xx Control Logic includes an optional BiQuad filter feature in the forward and feedback path of the velocity loop. Enable this feature by setting **FilterType** = BiQuad. There are 4 BiQuad blocks arranged per the diagram below. The S200 Tools program includes a filter design feature that calculates and loads the parameters for specific behaviors such as a low pass filter or lead / lag filter (see below). Each BiQuad is controlled by four 16-bit set point parameters. For example, BiQuad 0 is controlled by BQ0B1, BQ0B2, BQ0K1, BQ0K2. These parameters may be modified and saved to NV by normal S200 parameter methods.

**WARNING:** Disable the drive before changing any Biquad filter parameters. In the default ARfx mode you can change the filter values while the drive is enabled.

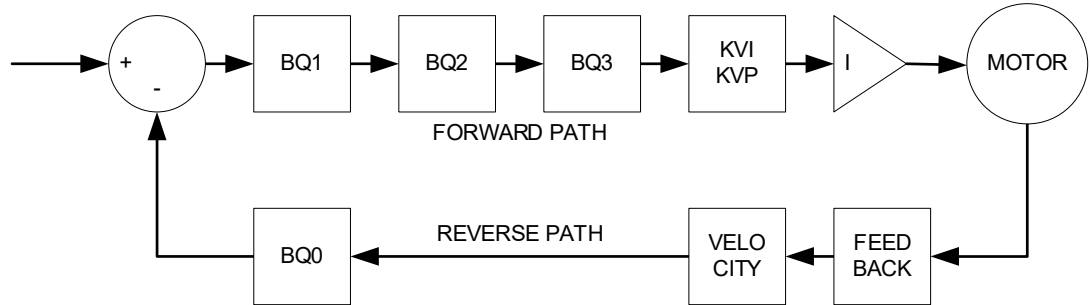

#### H.3.5.1 S200 TOOLS BIQ COEFFS PANE

The S200 Tools program displays the *Biq Coeffs* pane when the FilterType is BiQuad. The *Design* calculation tool can be used to configure common BiQuad functions as described in the following sections. For more complex BiQuad configurations, please contact Kollmorgen for support.

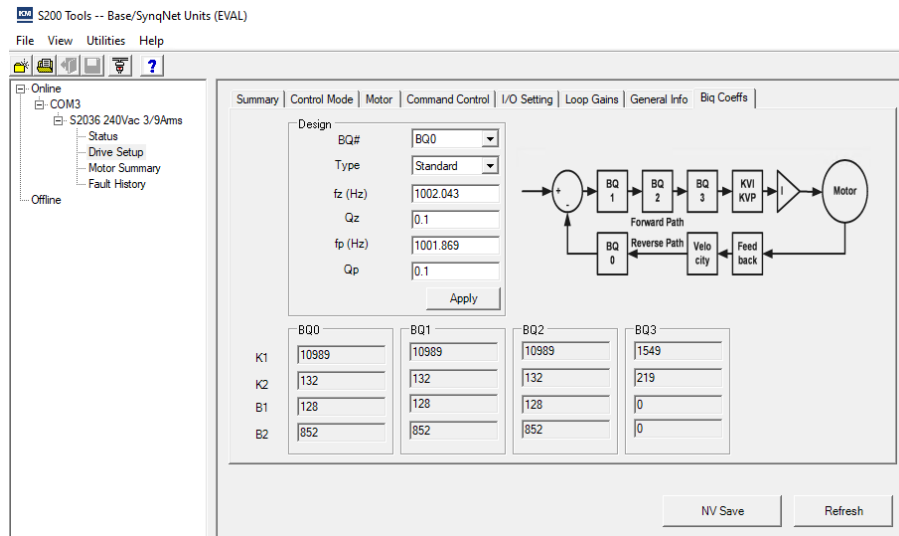



Design Type: Low Pass - Select the target BiQuad, enter the corner frequency, click Apply. This is a second order low pass filter.

The screenshot shows a dialog box titled "Design" for a Low Pass filter. It contains the following fields: "BQ#" is a dropdown menu set to "BQ0"; "Type" is a dropdown menu set to "Low Pass"; "Corner Freq (Hz)" is a text input field containing "100"; there are three additional text input fields, each containing "N/A"; and an "Apply" button at the bottom right.

Design Type: Lead / Lag - Select the target BiQuad, enter frequency and gains, click Apply.

The screenshot shows a dialog box titled "Design" for a Lead / Lag filter. It contains the following fields: "BQ#" is a dropdown menu set to "BQ0"; "Type" is a dropdown menu set to "Lead / Lag"; "Center Freq (Hz)" is a text input field containing "100"; "Low Freq Gain (dB)" is a text input field containing "0"; "High Freq Gain (dB)" is a text input field containing "5"; there is one additional text input field containing "N/A"; and an "Apply" button at the bottom right.

Design Type: Resonator -> Select the target BiQuad, enter frequencies and gain, click Apply.

The screenshot shows a dialog box titled "Design" for a Resonator filter. It contains the following fields: "BQ#" is a dropdown menu set to "BQ0"; "Type" is a dropdown menu set to "Resonator"; "Center Freq (Hz)" is a text input field containing "100"; "Bandwidth (Hz)" is a text input field containing "75"; "Gain (dB)" is a text input field containing "15"; there is one additional text input field containing "N/A"; and an "Apply" button at the bottom right.

Design Type: Unity/No signal change -> Select the target BiQuad, click Apply.

The screenshot shows a dialog box titled "Design" for a Unity/No signal change filter. It contains the following fields: "BQ#" is a dropdown menu set to "BQ0"; "Type" is a dropdown menu set to "Unity Gain"; there are four additional text input fields, each containing "N/A"; and an "Apply" button at the bottom right.

Design Type: Standard -> Select the target BiQuad, enter frequencies and gains, click Apply.

Design

BQ#

Type

fz (Hz)

Qz

fp (Hz)

Qp

Where the transfer function representation is:

$$F(s) = \frac{\frac{s^2}{\omega_z^2} + \frac{s}{Q_z \cdot \omega_z} + 1}{\frac{s^2}{\omega_p^2} + \frac{s}{Q_p \cdot \omega_p} + 1}$$

And the input parameters are:

$$f_z = \frac{\omega_z}{2\pi} \quad f_p = \frac{\omega_p}{2\pi}$$

Parameter	Range
fz, fp	5 Hz to 5000 Hz
Qz, Qp	.2 to 20

## **H.4 REGULATORY APPROVAL CHANGES.**

The S200 family of products was originally UL approved to UL 508 C. In 2015 UL announced UL 508C would be obsoleted on February 1, 2020 and that by then all new designs for this equipment class must be approved to UL 68100-5-1. UL 68100-5-1 is equal to or more stringent than UL 508 C and UL allows grandfather use of older product to UL 508 C or new product to UL 68100-5 in the same machine.

This UL regulation change means that any S200 product where the power board is updated is migrating from UL 508C to UL 68100-5-1. All HW Rev C units except the S22460 had their power boards changed and were updated to UL 68100-5-1. The S22460 Rev C product remains UL 508C even though it uses the new FPGA/Control Logic and has enhanced features.

Due to changes in the standard there need to be changes in how the power, current ratings of the product are listed. This will affect the rating numbers on the product label. However, there has been no change to product power or current capabilities. Product capability and specifications listed in section **3.1 Drive Family Power** have not changed except for the ac line currents due to changed operating conditions during the UL ac line ratings test.

## H.5 AGENCY RATINGS AND FUSE RECOMMENDATIONS

UL 61800-5-1 Specifications						
	S20250	S20350	S20260	S20360	S20660	S21260
<b>RMS Line Current at Continuous Output Power</b>						
100-240 Vac 3 Phase (A <sub>RMS</sub> )	-	-	2.6	4.5	7.3	14
100-240 Vac 1 Phase (A <sub>RMS</sub> )	-	-	4.2	7	11	16
100-120 Vac 1 Phase (A <sub>RMS</sub> ) Voltage Doubler	5	9.8	-	-	-	-
<b>Continuous Output Current</b>	<b>100-120 Vac Input Voltage Doubler</b>		<b>100-240 Vac Input</b>			
0 - 30° C amb (A <sub>RMS</sub> )	2.25	4.5	2.25	4.5	9.0	15.0
40° C amb (A <sub>RMS</sub> )	1.5	3.0	1.5	3.0	6.0	12.0
50° C amb (A <sub>RMS</sub> )	1.0	2.0	1.0	2.0	4.0	8.0
<b>Continuous Output Watts</b>	-	-	<b>240 Vac 3 phase</b>			
0 - 40° C amb (Watts)	-	-	600	1100	2000	4000
50° C amb (Watts)	-	-	400	730	1300	2500
<b>Continuous Output Watts</b>	<b>100-120 Vac Input Voltage Doubler</b>		<b>240 Vac 1 phase</b>			
0 - 40° C amb (Watts)	350	750	500	900	1500	2300
50° C amb (Watts)	230	500	333.3	597	975	1500
<b>Continuous Regen Watts</b>						
0 - 40° C amb (Watts)	440	640	440	640	1000	1500
50° C amb (Watts)	352	512	352	512	800	1200

Recommended Fusing Line Inputs	Voltage Doubler		S20260	S20360	S20660	S21260
	S20250	S20350				
<b>Type – Class J Time Delay Fuse 100 – 240 Vac Single or Three Phase</b>						
Mains Single Axis	7A	15A	6A	10A	15A	20A
Mains Group Installation	Up to 30A Class J					
Control Single Axis	1/2A Class CC					
Control Group Installation	Up to 1-6/10A Class CC or J					

\* For S22460 AC line and fuse specification see earlier UL 508C ratings in this manual.

Inrush Current at Control Power On	S20260	S20360	S20660	S21260
Max Inrush Peak Current at 240 Vac	10 A 0-p			
Inrush Pulse Width	1.6 ms			

Recommended Fuse AC Control Input	S20260	S20360	S20660	S21260
<b>Single Installation 600 Vac Time Delay Fuse</b>				
100-240 Vac 1 Phase (A <sub>RMS</sub> )	Bussmann LP-CC-1/2			
<b>Group Installation 600 Vac Time Delay Fuse</b>				
100-240 Vac 1 Phase (A <sub>RMS</sub> )	Bussmann LP-CC-1-6/10 Or LPJ-1-6/10SP			

Inrush Currents at Mains Power On	S20260	S20360	S20660	S21260
Max Inrush Peak Current at 240 Vac	140 A 0-p	140 A 0-p	240 A 0-p	None, soft start
Inrush Pulse Width	1.5 ms	1.5 ms	2.0 ms	NA

Recommended Fuses AC Mains Input	S20260	S20360	S20660	S21260
<b>Single Installation 600 Vac Time Delay Fuse</b>				
100-240 Vac 3 Phase (A <sub>RMS</sub> )	Bussmann LPJ-4SP	Bussmann LPJ -8SP	Bussmann LPJ-15SP	Bussmann LPJ-20SP
100-240 Vac 1 Phase (A <sub>RMS</sub> )	Bussmann LPJ-6SP	Bussmann LPJ-10SP	Bussmann LPJ-20SP	Bussmann LPJ-30SP
Voltage Doubler	<b>S20250</b>	<b>S20350</b>	NA	
100-120 Vac 1 Phase (A <sub>RMS</sub> )	Bussmann LPJ-6SP	Bussmann LPJ-10SP		
<b>Group Installation 600 Vac Time Delay Fuse</b>				
100-240 Vac 1/3 Phase (A <sub>RMS</sub> )	Bussmann LPJ-30SP			

## H.6 CE REGULATORY CERTIFICATION DETAILS

For the CE Declaration of Conformity to EN 61800-5-1 and EN61800-3 please see [www.kollmorgen.com](http://www.kollmorgen.com) under the S200 drive section to download a current copy.

## H.7 UL CRITERIA OF ACCEPTANCE

Marking - Industrial control equipment shall be plainly marked with (1) the Listee's name or "E141084", (2) electrical ratings, (3) the catalog number. All markings shall be located so as to be visible after installation.

Installation Instructions - Each controller is provided with installation instructions which include the following:

1. Identification of the terminals on the controller are coded so they may be identified in the instructions. The instructions shall identify power connections for power supply, load, control, and ground.
2. "Integral solid state short circuit protection does not provide branch circuit protection. Branch circuit protection must be provided in accordance with the National Electrical Code and any additional local codes", or the equivalent.
3. The following fuse types are required for S200 Logic Supply in the operating manual.

Model	Class	Ratings
S20260 S20360	CC	1/2A, 600V, 200kA max
S20250 S20350 S20660 S21260	CC	1/2A, 600V, 200kA max
Group Installation		
Model	Class	Ratings
S20250 S20260 S20350 S20360 S20660 S21260	J	1-6/10A, 600V, 300kA max
	CC	1-6/10A, 600V, 200kA max

4. The following fuse types are required for S200 mains in the operating manual.

Model	Class	Ratings
S20260 S20360	J	10A, 600V, 300kA max
S20250 S20350 S20660	J	15A, 600V, 300kA max
S21260	J	20A, 600V, 300kA max
Group Installation		
Model	Class	Ratings
S20250 S20260 S20350 S20360 S20660 S21260	J	Max. 30A, 600V 300kA max

5. These drives provide solid state motor overload protection at 125% of the rated FLA Current.
6. These drives are intended for use in a Pollution Degree 2 environment.
7. "Use minimum 75°C Copper Wire"

8. The following table illustrates the torque requirements for the field wiring connectors:

Model	Mains Connector (in-lbs)	Motor Phase Connector (in-lbs)
S20250 S20260 S20350 S20360 S20660	4.4 - 5.3	4.4 - 5.3
S21260	Control Power Connector (in-lbs) J1	Mains & Motor Phase Connector (in-lbs) TB1
	4.4 - 5.3	12.4-14.2 Prepared 14.2-16 Stranded
S22460		10.5-15

9. Maximum Ambient temperature of 40°C de-rated up to 55C.
10. Warning Markings – The following marking should be provided on the device or equivalent.
- “CAUTION – Risk of Electric Shock”, followed by instructions to discharge the specific capacitor or indicating the time required for the capacitor to discharge to a level below 50 V DC.

**CAUTION – Risk of electric shock, Residual Voltage Wait 5 min. after removing power before servicing. See manual.**

- “ATTENTION – The opening of branch-circuit protective device may be an indication that a fault has been interrupted. To reduce the risk of fire or electric shock, current-carrying parts and other components of the controller should be examined and replaced if damaged.”

- Example: ATTENTION – Opening of branch-circuit, see manual
- Example: ATTENTION – Opening of branch-circuit protective device indicates a fault. To reduce risk of fire or electric shock, examine controller & replace any damaged components.

<p><b>CAUTION</b> – Risk of electric shock  <b>ATTENTION</b> – Opening of branch-circuit protective device indicates a fault. To reduce risk of fire or electric shock, examine controller &amp; replace any damaged components.</p>
--

11. Industrial control equipment must be placed in an enclosure with a min. size of

S202xx, S203xx, S206xx:	16" x 18" x 8"
S21260:	16" x 16" x 10"

12. Suitable for motor group installation on a circuit capable of delivering not more than 5,000 rms symmetrical amperes, 240 V max when protected by Class J fuses.