

PRICE: \$17.50

**INSTALLATION  
INSTRUCTIONS  
for  
SLO-SYN<sup>®</sup> MICRO SERIES  
230 and 430  
PACKAGED DRIVES**



**Superior Electric**

Bristol, Connecticut 06010-7488



# TABLE OF CONTENTS

## THINGS TO KNOW BEFORE USING THIS EQUIPMENT

	Page
<b>SECTION 1: INTRODUCTION</b>	<b>3</b>
1.1 Using This Manual	3
1.2 Product Features	3
<b>SECTION 2: EXPRESS START UP PROCEDURE</b>	<b>3</b>
<b>SECTION 3: INSTALLATION GUIDELINES</b>	<b>4</b>
3.1 General Wiring Guidelines	4
3.2 Mounting	6
3.3 Selecting Input Voltage Range	7
3.4 Connector Locations And Pin Assignments	8

<b>SECTION 4: SPECIFICATIONS</b>	<b>12</b>
4.1 Mechanical Specifications	12
4.2 Electrical Specifications	12
4.3 Environmental Specifications	12
4.4 Motor Compatibility	13
4.5 Reduce Current Operation	13
4.6 Indicator Lights	13
<b>SECTION 5: TORQUE VERSUS SPEED CHARACTERISTICS</b>	<b>14</b>
<b>SECTION 6: TROUBLESHOOTING</b>	<b>27</b>
<b>APPENDIX A: TROUBLESHOOTING ELECTRICAL INTERFERENCE PROBLEMS</b>	<b>27</b>

© 1990, The Superior Electric Company.

## THINGS TO KNOW BEFORE USING THIS EQUIPMENT

- Only qualified personnel should install or perform servicing procedures on this equipment. Do not operate the unit without the enclosures in place as voltage present in this unit can cause serious or fatal injury.
- Before performing any work on the unit, allow at least five minutes for the capacitors to discharge fully.
- Voltage is present on unprotected pins when unit is operational.
- The "PWR ON" LED must be off for approximately 30 seconds before connecting or disconnecting the motor connector. **Failure to turn the power off may result in damage to the drive and/or motor connector.**
- Motors powered by this drive may develop extremely high torque. Be sure to disconnect ac power to this drive before doing any mechanical work.

## WARRANTY RESTRICTIONS

Reconfiguration of the circuit in any fashion not shown in this manual will void the Warranty.

Failure to follow the proper wiring practices as described in Section 3.1 will void the Warranty.

# SECTION 1: INTRODUCTION

## 1.1 USING THIS MANUAL

It is important that you understand how the 230 or 430 Series unit is installed and operated before you attempt to use it. **We strongly recommend that you read this manual completely before proceeding with the installation of this unit.**

This manual is an installation and operating guide to the Drive section of 230 and 430 model Micro Series Motion Controls. These models can be supplied as Translators, Translator/Oscillators or Indexers. Instructions for the control portion (Translator, Translator/Oscillator or Indexer) of the unit are given in the attached manual.

Section 1 gives an overview of the Drive and its features. Section 2 describes the steps necessary to place the drive portion of the unit into operation. General wiring guidelines as well as the Physical mounting of the unit and connections to the drive portion are covered in Section 3.

Complete specifications, listed in Section 4, provide easily referenced information concerning electrical, mechanical and performance specifications. The procedure for reconfiguring the drive to provide a reduced motor current level is also covered in this section.

Torque versus speed characteristics with all appropriate SLO-SYN Stepper Motors are given in Section 5.

Section 6, Troubleshooting, gives procedures to follow if the drive fails to operate properly.

Appendix A provides procedures for troubleshooting electrical interference problems.

## 1.2 PRODUCT FEATURES

230 and 430 model Micro Series Drives are low cost, energy efficient, drives which can provide full or half step operation of a SLO-SYN Stepper Motor. They are available as Translators, Translator/Oscillators, Preset Indexers or Programmable Indexers. The maximum running speed is 10,000 full steps per second. To reduce the chances of electrical noise problems, the control signals are optically isolated from the drive circuit.

The 230 and 430 drives are differentiated as follows:

	MOTOR CURRENT PER PHASE	VA PER PHASE
230 Models	2 amperes peak	56 VA nominal
430 Models	3.5 amperes peak	96 VA nominal

# SECTION 2: EXPRESS START UP PROCEDURE

The following instructions define the minimum steps necessary for the **Drive** section of your unit to become operational. Be sure to follow the Express Start Up Procedure for the Control section of the unit as given in the attached Instruction Manual.

### CAUTION:

**Always disconnect the ac power to the unit and be certain that the "PWR ON" LED is OFF before connecting or disconnecting the motor connector or leads. FAILURE TO DO THIS WILL RESULT IN DAMAGE TO THE DRIVE.**

**Always operate the Motor and the Drive GROUNDED. Be sure to twist together the wires for each motor phase. Six twists per foot is a good guideline.**

1. Check to see that the motor used is compatible with the drive. Refer to Section 4.4 for a list of compatible motors.
2. If operation at a reduced motor current level is desired, follow the instructions in Section 4.5.

3. Wire the motor per the "Motor Connections" description in Section 3.4.
4. Connect 120 volts ac, 50/60 hertz to the AC input terminal strip. The terminal labeled "H" is hot, "C" is common and "G" is ground.

NOTE: If motor operates erratically, refer to Section 5, "Torque Versus Speed Characteristics".

Clockwise and counterclockwise directions are properly oriented when viewing the motor from the label end.

### MOTOR CONNECTOR PART NUMBERS FOR 230 AND 430 SERIES PACKAGED DRIVES

(This connector mates with the female motor connector on drive)

Male Connector Body: AMP part number 206434-1  
Pins (5 required): AMP part number 66506-8  
Cable Clamp: AMP part number 206062-1

# SECTION 3: INSTALLATION GUIDELINES

## 3.1 GENERAL WIRING GUIDELINES

SLO-SYN Micro Series drives use modern solid-state electronics such as microprocessors to provide the features needed for advanced motion control applications. In some cases, these applications produce electromagnetic interference (EMI, or electrical "noise") that may cause inappropriate operation of the microprocessor logic used in the Micro Series product, or in any other computer-type equipment in the user's system.

In general, any equipment that causes arcs or sparks or that switches voltage or current at high frequencies can cause interference. In addition, ac utility lines are often "polluted" with electrical noise from sources outside a user's control (such as equipment in the factory next door). Some of the more common causes of electrical interference are:

- power from the utility ac line
- relays, contactors and solenoids
- light dimmers
- arc welders
- motors and motor starters
- induction heaters
- radio controls or transmitters
- switch-mode power supplies
- computer-based equipment
- high frequency lighting equipment
- dc servo and stepper motors and drives

The following wiring practices should be used to reduce noise interference.

**Failure to properly wire the system will void the Warranty.**

- **Solid grounding of the system is essential.** Be sure that there is a solid connection to the ac system earth ground. Bond the drive case to the system enclosure. Use a single-point grounding system for all related components of a system (a "hub and spokes" arrangement). Keep the ground connection short and direct.
- **Keep signal and power wiring well separated.** If possible, use separate conduit or ducts for each. If the wires must cross, they should do so at right angles to minimize coupling.

Note: Power wiring includes ac wiring, motor wiring, etc. and signal wiring includes inputs and outputs (I/O), serial communications (RS232 lines), etc.

- **Use shielded, twisted-pair cables for Indexer I/O lines. BE SURE TO GROUND SHIELDS ONLY AT ONE END, THE INDEXER/DRIVE END.**
- **Suppress all relays to prevent noise generation.** Typical suppressors are capacitors or MOV's. (See manufacturer's literature for complete information). Whenever possible, use solid-state relays instead of mechanical contact types to minimize noise generation.

If you are experiencing problems with drive operation which might be related to EMI, refer to Appendix A for troubleshooting pointers.

# Recommended Wiring Practices

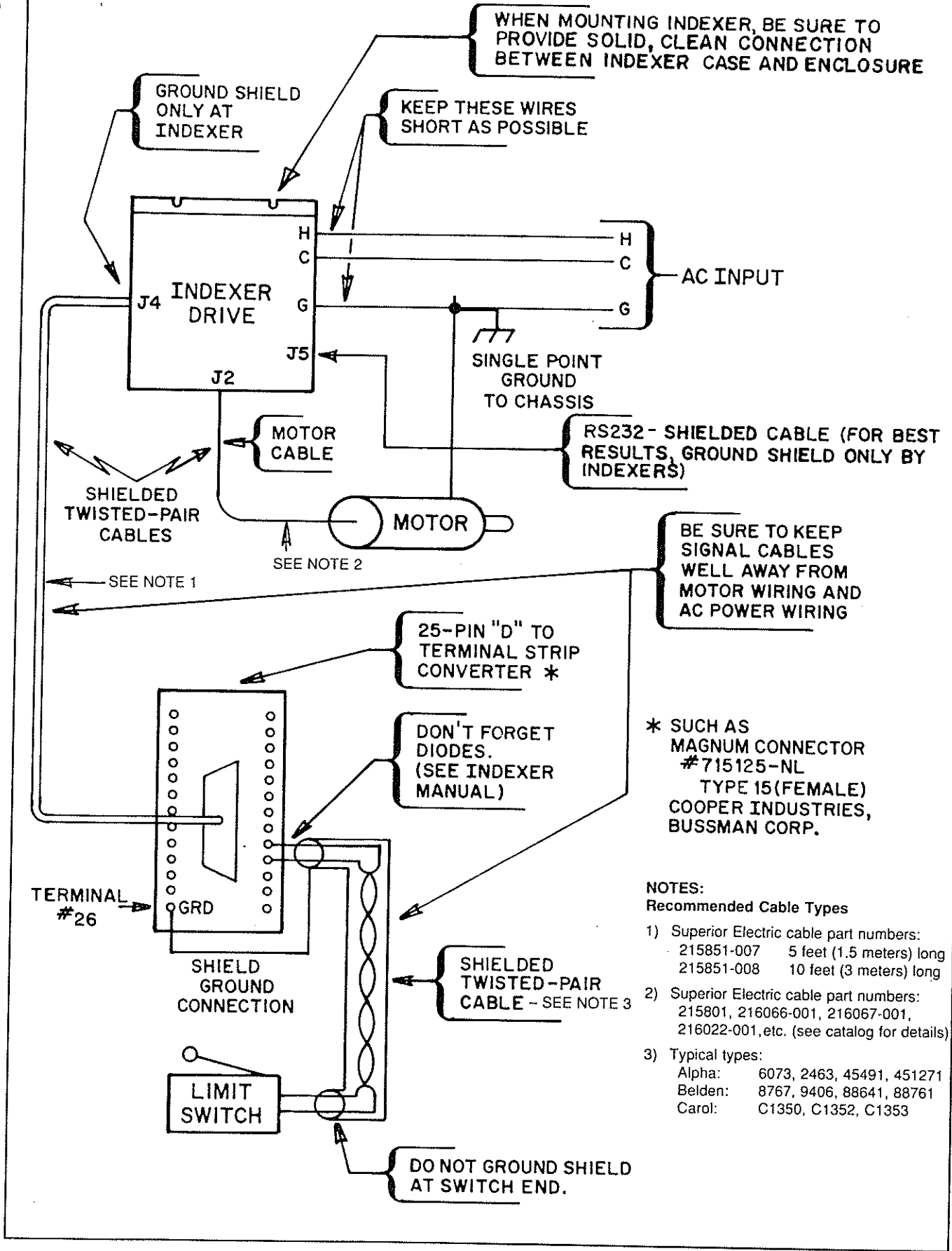

Figure 3.1

### 3.2 MOUNTING

The 230 or 430 Series Motion Control is mounted by fastening its mounting brackets to a flat surface. The mounting brackets can be located in either of two positions. Figure 3.2 shows the locations and diameters of the mounting holes and indicates the possible locations of the brackets.

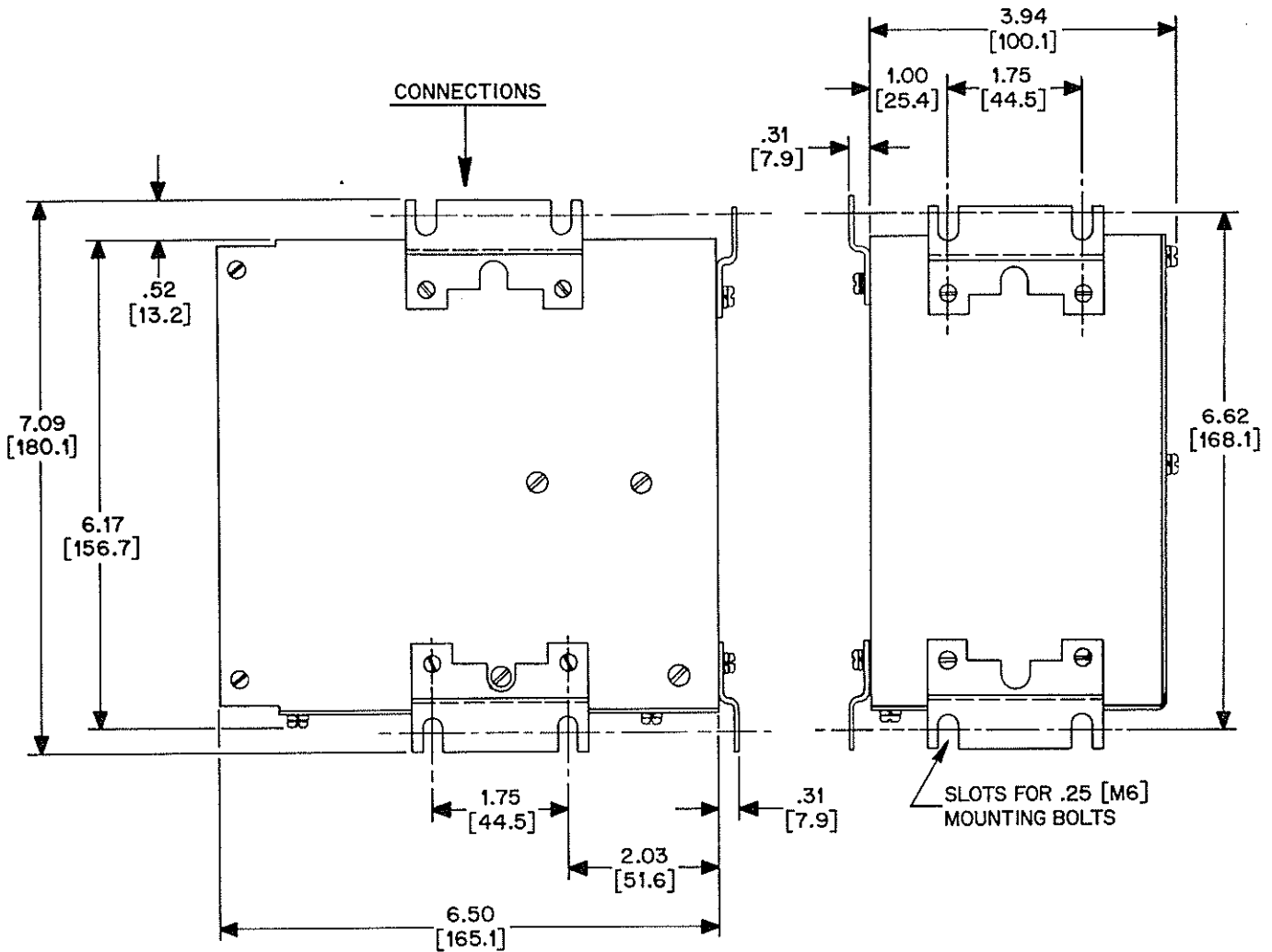

Figure 3.2, Mounting Diagram

**NOTE:** The heat sink should always be mounted with the fins oriented vertically, or proper cooling will not occur. Air flow should not be obstructed. Heat sink temperature should not exceed +70°C (+158°F). Forced air cooling may be required to maintain temperature within the stated limits.

When selecting a mounting location, it is important to leave at least two inches (51mm) of space around the top, bottom and sides of the unit to allow proper airflow for cooling.

It is also important to keep the drive away from obvious noise sources. If possible, locate the drive in its own metal enclosure to shield it and its wiring from noise sources. If this cannot be done, keep the drive at least three feet from any noise sources.

### 3.3 SELECTING INPUT VOLTAGE RANGE (models with letter "X" in type number only)

230 and 430 Drives which have a letter "X" in their type numbers can operate from nominal input voltages of 220, 230 or 240 volts, 50/60 hertz. Before connecting the unit to an ac voltage source, select the desired nominal input voltage level as described below. The factory default is 240 volts.

1. Disconnect any motor, logic or input power cables from the unit.
2. Place the unit so the heat sink is up and the connectors are facing to the left. Remove the following six screws:
  - A. Four screws located on the nameplate panel (two screws fasten to the heat sink, one is adjacent to the motor connector and the fourth is at the bottom center of the panel (see Figure 3.3A).

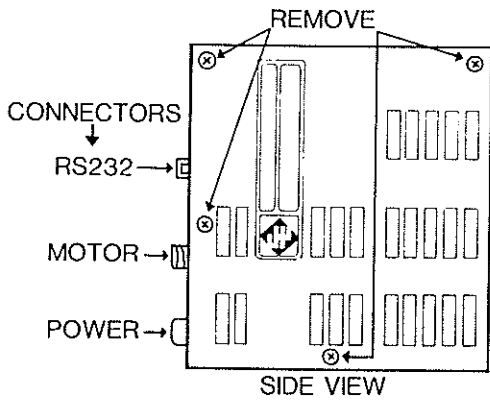

Figure 3.3A

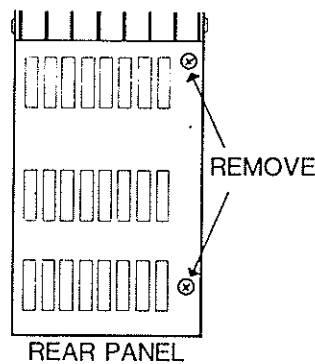

Figure 3.3B

3. Three input taps labeled 220V, 230V and 240V are located on the transformer. A wire is connected to one of these taps via a quick-disconnect terminal. Unplug this wire and connect it to the tap which corresponds to the desired nominal input voltage (see Figure 3.3C). Be sure to seat the connector so that it is held firmly in place.
4. Reinstall the side panel and its six screws in reverse order of assembly.
5. Reconnect the motor, logic and power input cables.

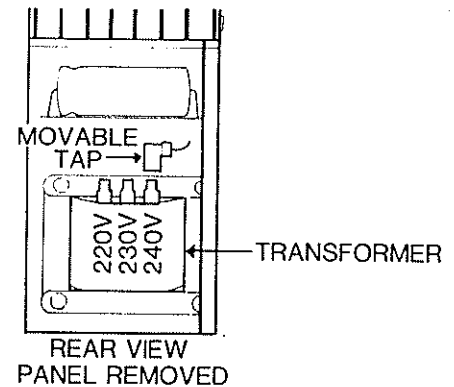

Figure 3.3C

### 3.4 CONNECTOR LOCATIONS AND PIN ASSIGNMENTS

Figure 3.4 shows the connector locations for 230 and 430 Series Drives.

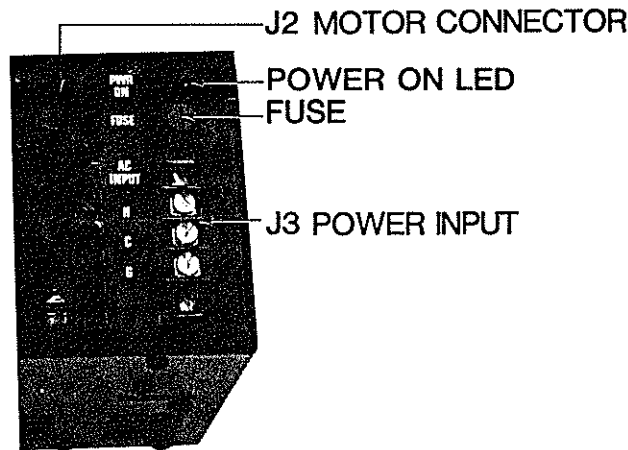

Figure 3.4, Connector Locations

### MOTOR CONNECTIONS

All motor connections are made via the 8-pin circular AMP connector. Pin assignments for this connector are:

Pin	Assignment
1	M4
2	M1
3	No Connection
4	Ground
5	No Connection
6	M5
7	No Connection
8	M3

**NOTE:** Motor phase A is M1 and M3 and motor phase B is M4 and M5.

AMP male connector 206434-1 (AMP pin part number 66506-8 and cable clamp part number 20606-1) will mate with this connector.

Cabling from the drive to the motor should be done with a shielded, twisted pair cable. As a guideline, the wires for each motor phase should be twisted about six times per foot. Superior Electric offers the following motor cable configurations:

Length	Unterminated Leads On Motor End) Part Number	(Plug On Motor End)* Part Number
10 ft. (3 m)	B215801-001	B216066-001
25 ft. (7.6 m)	B215801-002	B216066-002
50 ft. (15.2 m)	B215801-003	B216066-003

\* Mates with receptacle on M061, M062 and M063 motors equipped with connectors (M061-CS08, etc.).

Figure 3.5 shows the proper motor wiring configuration.



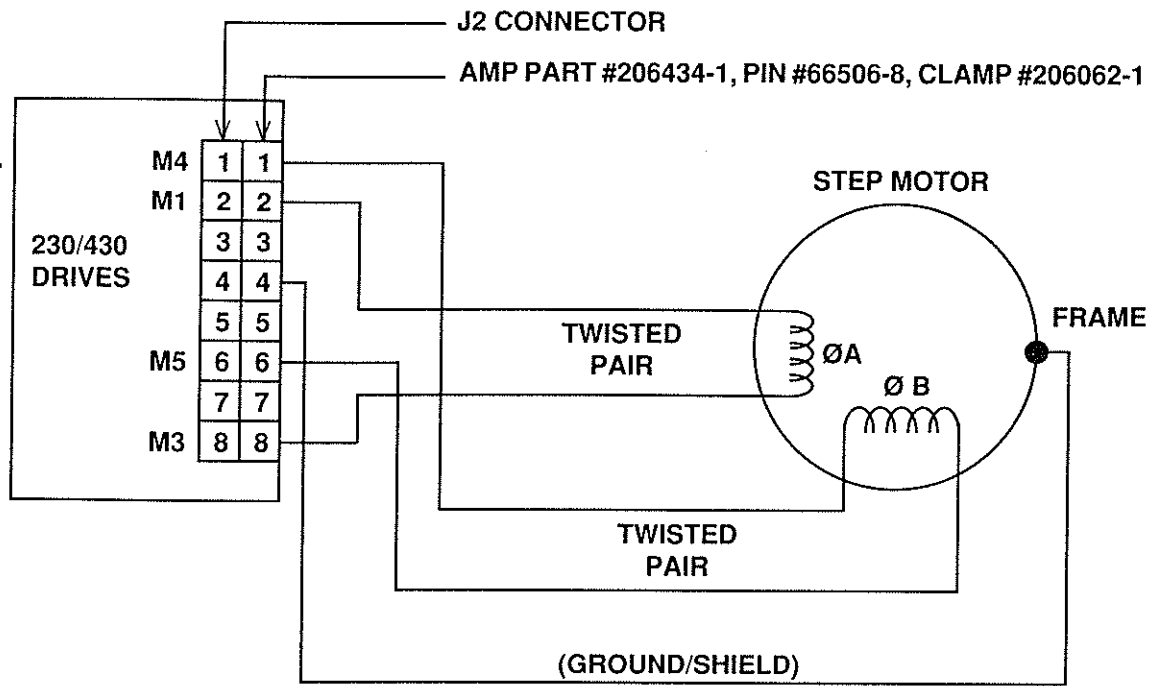

NOTE: Wires connected to Pins 1 and 6 should be twisted, as well as those connected to Pins 2 and 8, approximately 6 twists per foot. The two pairs should then be shielded to minimize radiated EMI.

Figure 3.5, Motor Wiring Configurations

The diagrams in Figures 3.6 through 3.9 show connections for each motor type.

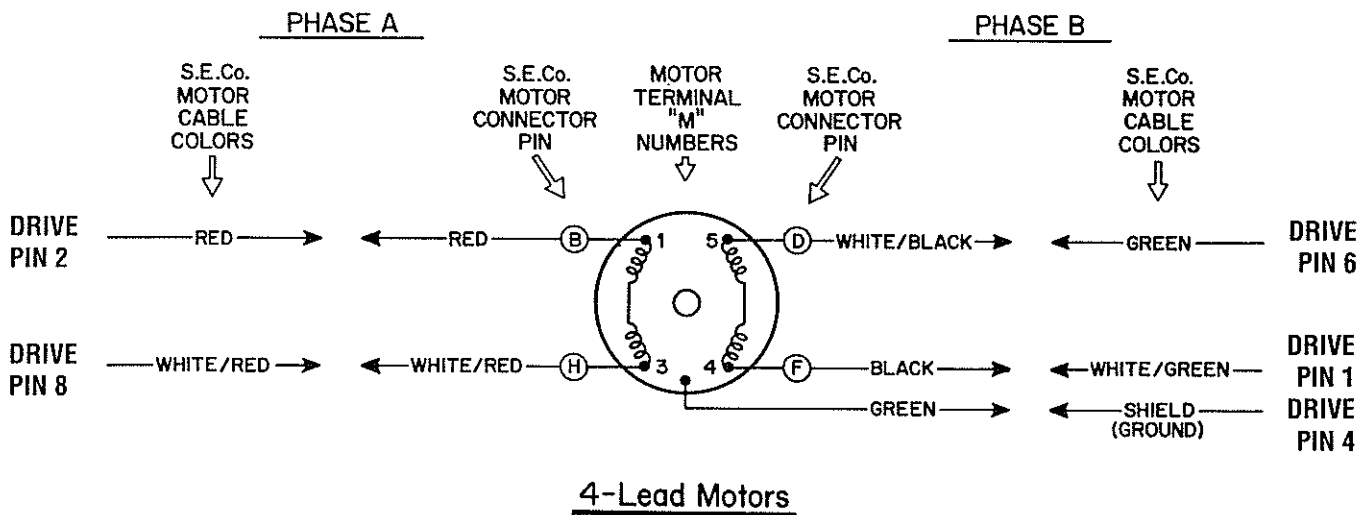
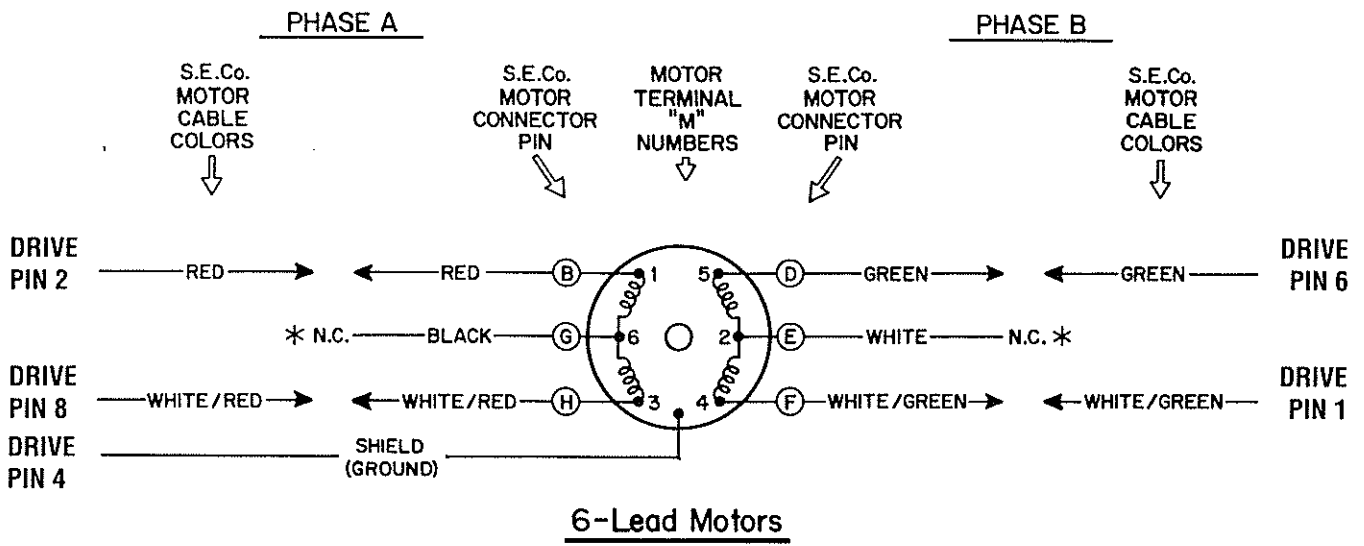
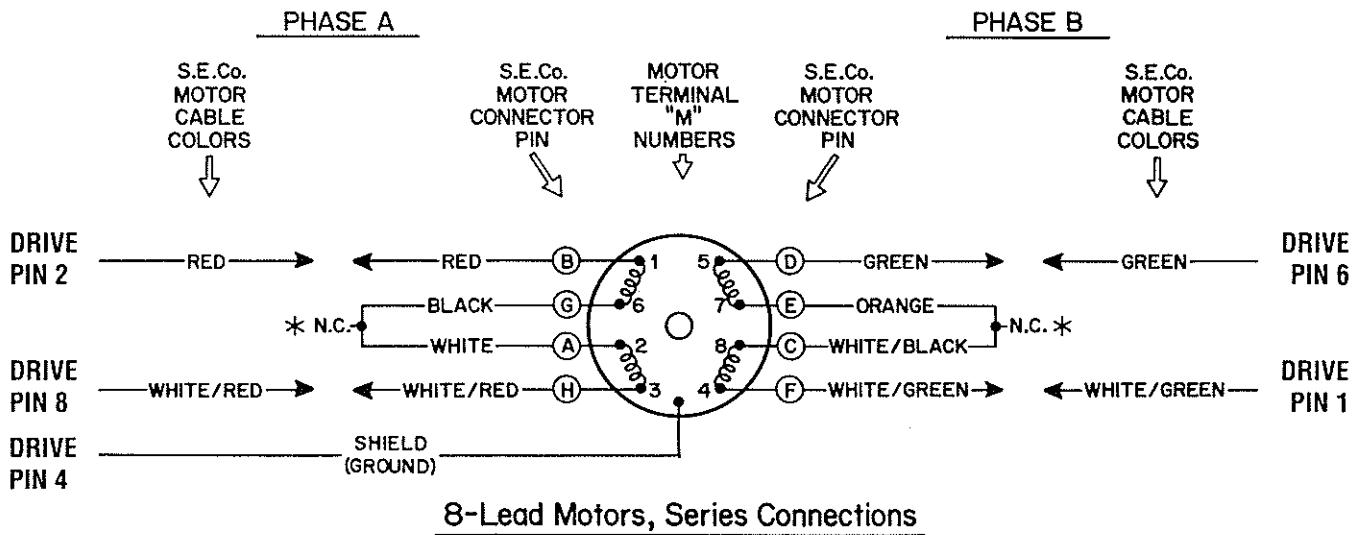

Figure 3.6, Four -Lead Motor Connections



\* = NOT connected to drive or ground. These leads must be insulated and isolated or damage to drive may occur.

Figure 3.7, Six-Lead Motor Connections



\* = NOT connected to drive or ground. These leads must be insulated and isolated or damage to drive may occur.

Figure 3.8, Eight-Lead Motors, Series Connection

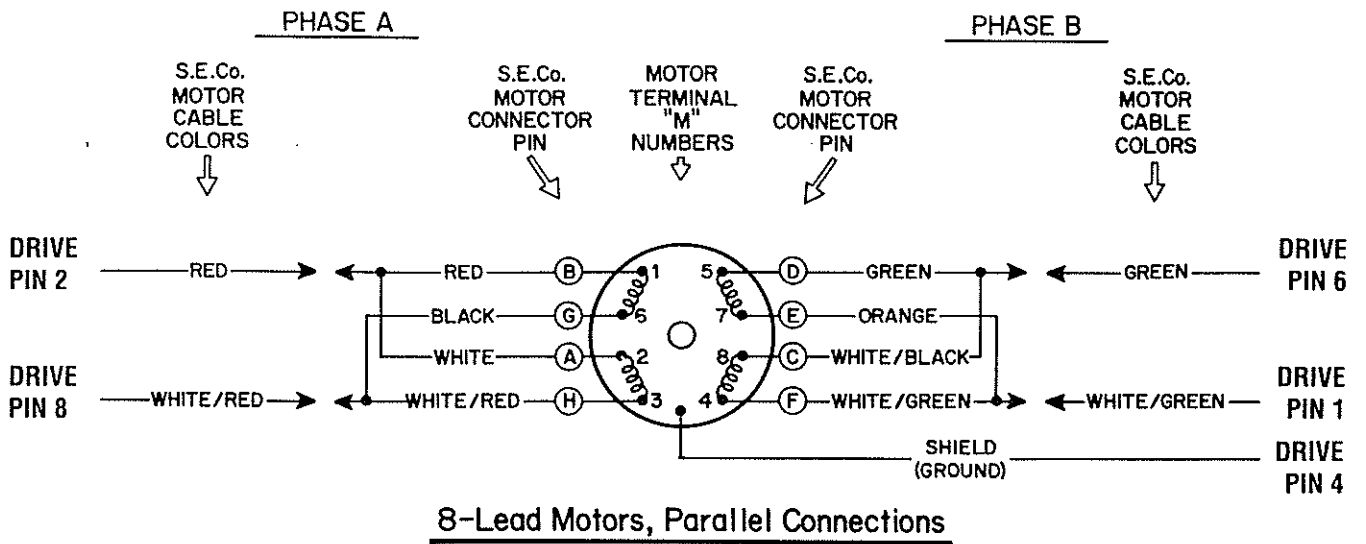

Figure 3.9, Eight-Lead Motors, Parallel Connections

### POWER INPUT

The ac power is connected to a 3-screw terminal strip. The terminals are labeled:

- "H" for Hot (black)
- "C" for Common or Neutral (white)
- "G" for Ground (green)

# SECTION 4: SPECIFICATIONS

## 4.1 MECHANICAL SPECIFICATIONS

### TRANSLATOR DRIVES

Size	
(Inches)	6.5 W x 3.94 D x 7.09 H (height over connectors, excluding mounting flanges. Height with flanges is 7.31 inches)
(mm)	165.1 W x 100.01 D x 180.1 H
Weight	
230 Models	8.5 pounds (3.7 kg)
430 Models	9.0 pounds (4.07 kg)

### TRANSLATOR/OSCILLATORS, PRESET INDEXERS, PROGRAMMABLE INDEXERS

Size	
(Inches)	6.5 W x 3.94 D x 7.09 H (height over connectors, excluding mounting flanges. Height with flanges is 7.31 inches)
(mm)	165.1 W x 100.01 D x 180.1 H
Weight	
230 Models	8.5 pounds (3.7 kg)
430 Models	9.0 pounds (4.07 kg)

## 4.2 ELECTRICAL SPECIFICATIONS

AC Voltage	
230 And 430	102 to 132 volts, 50/60 hertz
230 And 430 (X Models)	187 to 242 volts (220 nominal), 50/60 hertz 196 to 253 volts (230 nominal), 50/60 hertz 204 to 264 volts (240 nominal), 50/60 hertz
AC Current	
230 Drive	1.0 ampere
230X Drive	0.5 ampere
430 Drive	1.5 ampere
430X Drive	0.75 ampere
Fuse Rating	250 volts, 3 amperes (slow blow)
Fuse Type	Littelfuse part number 326003 or Bussman part number MDA-3*

### Drive Power Dissipation

(Worst Case)

230 Models	45 watts (drive only) 50 watts (drive plus control)
430 Models	65 watts (drive only) 70 watts (drive plus control)

\* If this fuse blows, the power supply will be prevented from energizing any of its outputs, hence, the unit will not operate. Usually, this fuse will only blow if an internal failure occurs. Therefore, if an open fuse condition occurs, the unit must be returned to the factory for service. **DO NOT REPLACE THE FUSE OR THE UNIT MAY BE FURTHER DAMAGED.**

## 4.3 ENVIRONMENTAL SPECIFICATIONS

Operating Temperature	+32° F to +122° F (0° C to +50° C) free air ambient
Storage Temperature	-40° F to +167° F (-40° C to +75° C)
Drive Heatsink Operating Temperature	+32° F to +158° F (0° C to +70° C)
Humidity	95% max. noncondensing
Altitude	10,000 feet (3048 m) max.
Cooling	will operate up to 122° F (50° C) as long as maximum heat sink temperature of 158° F (70° C) is maintained; forced-air (fan) cooling may be required.

**Note: Forced-air cooling may be required when operating a 430 model at ambient temperatures greater than +95° F (+35° C). If the heatsink temperature exceeds +158° F (+70° C), forced-air cooling MUST BE used.**

## 4.4 MOTOR COMPATIBILITY

	230 MODELS	430 MODELS
Motor Types	M Series	M Series
Frame Sizes	M061 thru M092	M061 thru M112
No. of Connections	4, 6 or 8	4, 6 or 8
Minimum Inductance	0.55 mH	0.55 mH
Max. Resistance	3.5 ohms including drive-to-motor cable	

**Table 4.1, Motor Families and Drive Compatibility**

### MOTORS FOR USE WITH 230 DRIVES

All motors listed here for use with 230 Series drives operate at 2 amperes in either series or parallel connection.

#### MOTORS WITH CONNECTORS

M061-CS08	M062-CS09	M063-CS06
M061-CE08	M062-CE09	M063-CS09
		M063-CE09

#### MOTORS WITH LEADS

M061-LS08	M063-LE09	M092-FD09
M061-LE08	M091-FC09	M092-FD310
M062-LS09	M091-FD09	M092-FD8009
M062-LE09	M091-FD8009	M092-FD8109
M063-LS06	M091-FD8109	M092-FD8814
M063-LS09		

### MOTORS FOR USE WITH 430 DRIVES

Except as noted, all motors listed here for use with 430 Series drives operate at 3.5 amperes in either series or parallel connection.

#### MOTORS WITH CONNECTORS

M061-CS08	M062-CE09	M063-CS09
M061-CE08 <sup>1</sup>	M063-CS06	M063-CE09
M062-CS09	M063-CE06 <sup>2</sup>	

#### MOTORS WITH LEADS

M061-LS08	M091-FD06 <sup>3</sup>	M093-FD8011
M061-LE08 <sup>1</sup>	M091-FD8106	M093-FD8014
M062-LS09	M092-FC09	M111-FD12
M062-LE09	M092-FD09	M111-FD16
M063-LS06	M092-FD310	M111-FD8012
M063-LE06 <sup>2</sup>	M092-FD8009	M112-FD327
M063-LS09	M092-FD8109	M112-FD8012
M063-LE09	M093-FC14	M112-FJ8012
M091-FC06 <sup>3</sup>	M093-FD14	M112-FJ8030

NOTE: For series operation, motor current must be reduced as described in Section 4.5.

1. Use 2.75 ampere setting.
2. Use 2.0 ampere setting.
3. Use 2.25 ampere setting.

## 4.5 REDUCED CURRENT OPERATION

**WARNING:** The following procedure requires disassembly of the enclosure and skilled workmanship must be accomplished. Failure to strictly follow these procedures or entering the enclosure for any other purpose will void the warranty. **ALWAYS DISCONNECT POWER AND ALL CABLES BEFORE PROCEEDING. REASSEMBLE THE ENCLOSURE BEFORE REAPPLYING POWER.**

The 230 and 430 Drives can be reconfigured to supply less than rated current to the motor. To do this, a jumper or a resistor is connected between LOGIC COMMON (pin 3) and REDUCE CURRENT (pin 4) on the 8-pin connector to the Interface circuit card. These pins protrude through holes in the interface circuit card.

To gain access to the pins, first remove the six screws that hold the nameplate side of the enclosure in position and remove it (see Figure 3.3A). Then remove the two screws that fasten the heatsink to the other side of the enclosure. Pivot the heatsink together with the attached drive module and Interface card away from the assembly to gain access to pins 3 and 4 of J5.

Care should be taken to **keep the resistor or jumper leads less than 2 inches (51 mm) long and to prevent them from contacting each other or any other part of the assembly.** This signal is not optically isolated.

The proper resistor values or jumper leads and their associated current values are shown in the following two Sections.

#### Reduced Current For 230 Models

CURRENT (amps)	RESISTOR (ohms)
1.00	0 (jumper)
1.25	2.49 k, 1/4 watt, 1%
1.50	7.50 k, 1/4 watt, 1%
1.75	23.7 k, 1/4 watt, 1%
2.0	open

#### Reduced Current For 430 Models

CURRENT (amps)	RESISTOR (ohms)
1.5	0 (jumper)
1.75	0.825 k, 1/4 watt, 1%
2.0	1.78 k, 1/4 watt, 1%
2.25	3.48 k, 1/4 watt, 1%
2.5	5.62 k, 1/4 watt, 1%
2.75	9.09 k, 1/4 watt, 1%
3.0	16.2 k, 1/4 watt, 1%
3.25	42.2 k, 1/4 watt, 1%
3.5	open

## 4.6 INDICATOR LIGHTS

"PWR ON" LED, Red

Lights when the +5V drive logic power supply is present, indicating that the drive is energized.

# SECTION 5: TORQUE VERSUS SPEED CHARACTERISTICS

All stepper motors exhibit instability at their natural frequency and harmonics of that frequency. Typically, this instability will occur at speeds between 50 and 500 full steps per second and, depending on the dynamic motor load parameters, can cause excessive velocity modulation or improper positioning.

There are also other instabilities which may cause a loss of torque at stepping rates outside the range of natural resonance frequencies. One such instability is broadly defined as mid-range instability. This is identified by the dotted area (...) on the torque versus speed curves.

Usually, the dampening of the system and acceleration/deceleration through the resonance areas aid in reducing instability to a level that provides smooth shaft velocity and accurate positioning. If instability does cause unacceptable performance under actual operating conditions, the following techniques can be used to reduce velocity modulation.

- 1) Avoid constant speed operation at the motors unstable frequencies. Select a base speed that is above the motors resonant frequencies and adjust acceleration and deceleration to move the motor through unstable regions quickly.
- 2) The motor winding current can be reduced as discussed in Section 4.5. Lowering the current will reduce torque proportionally. The reduced energy delivered to the motor can decrease velocity modulation.
- 3) Use the half-step mode of operation to provide smoother operation and reduce the effects of mid range instability. Note that half-stepping reduces the shaft speed for a given pulse rate.

## TYPICAL TORQUE VERSUS SPEED CURVES 230 SERIES MOTION CONTROLS

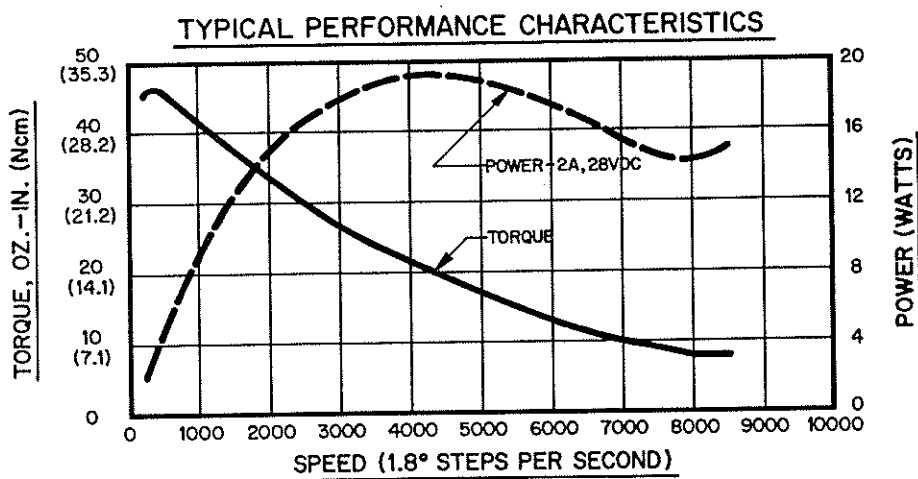

SERIES CONNECTION - M061-CS08 AND M061-LS08 MOTORS

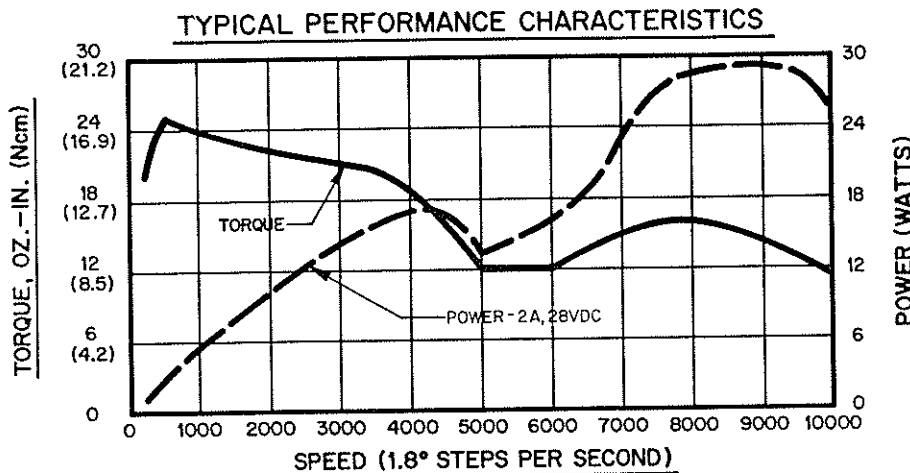

PARALLEL CONNECTION - M061-CE08 AND M061-LE08 MOTORS

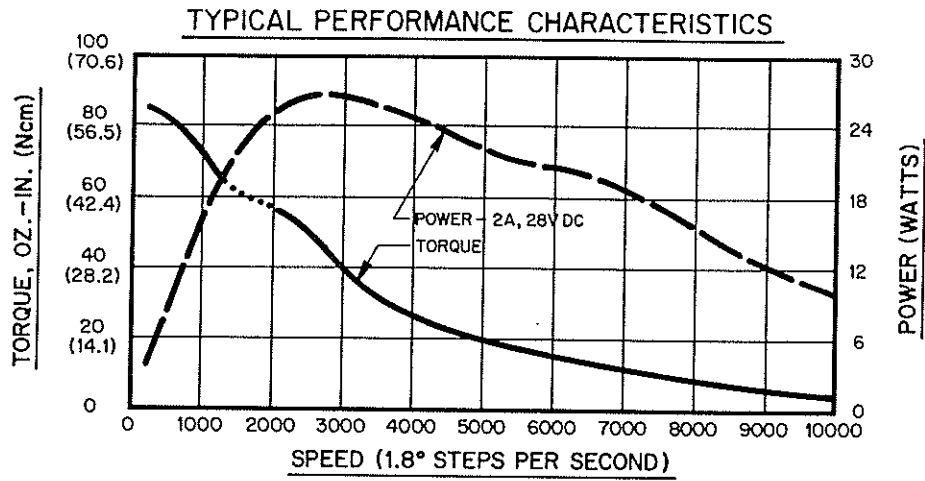

SERIES CONNECTION - M062-CS09 AND M062-LS09 MOTORS

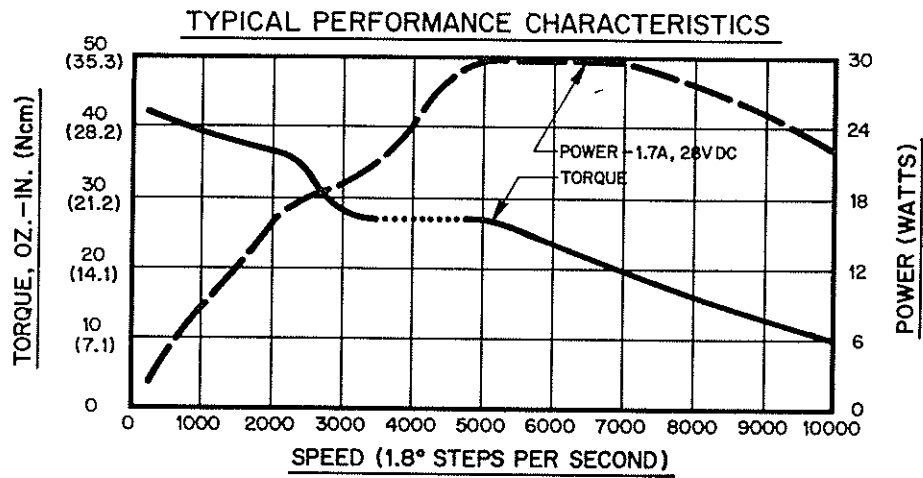

PARALLEL CONNECTION - M062-CE09 AND M062-LE09 MOTORS

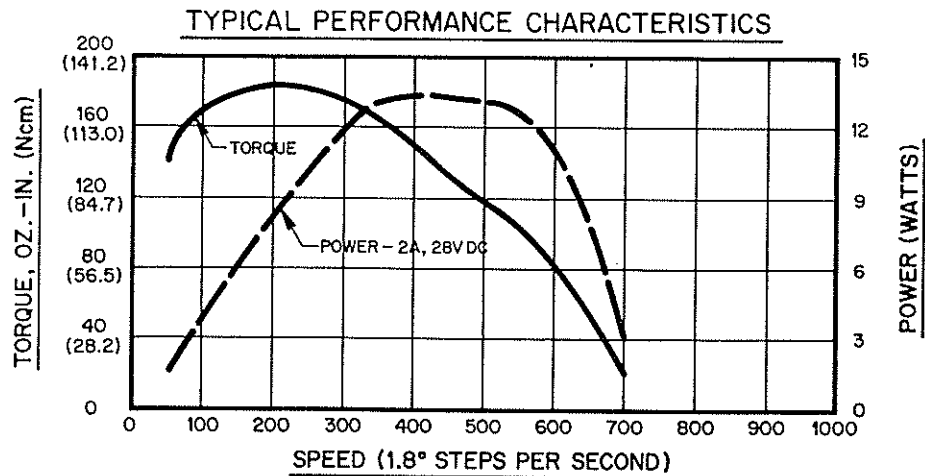

SERIES CONNECTION - M063-CS06 AND M063-LS06 MOTORS

### TYPICAL PERFORMANCE CHARACTERISTICS

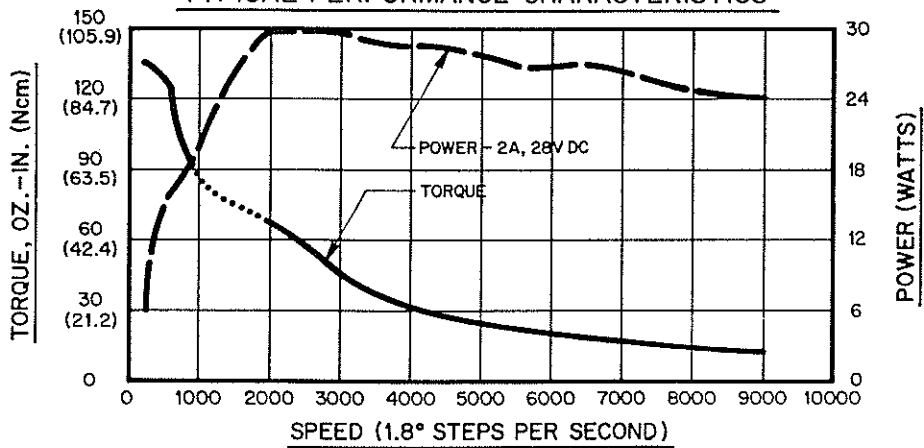

SERIES CONNECTION - M063-CS09 AND M063-LS09 MOTORS

### TYPICAL PERFORMANCE CHARACTERISTICS

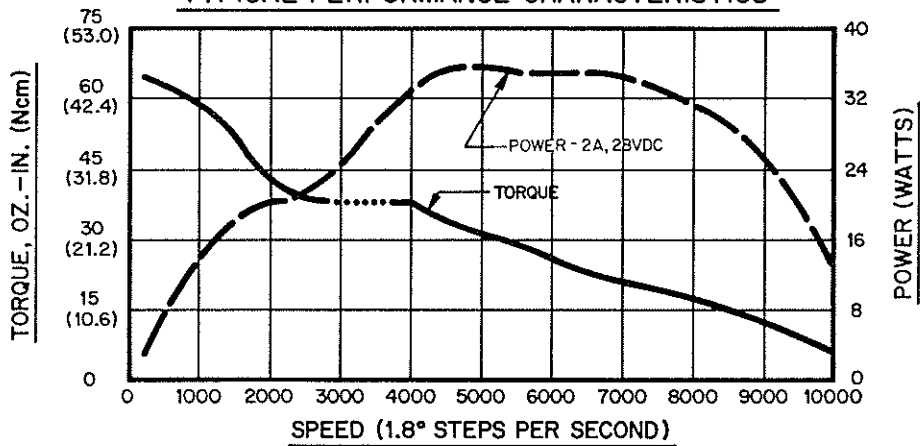

PARALLEL CONNECTION - M063-CE09 AND M063-LE09 MOTORS

### TYPICAL PERFORMANCE CHARACTERISTICS

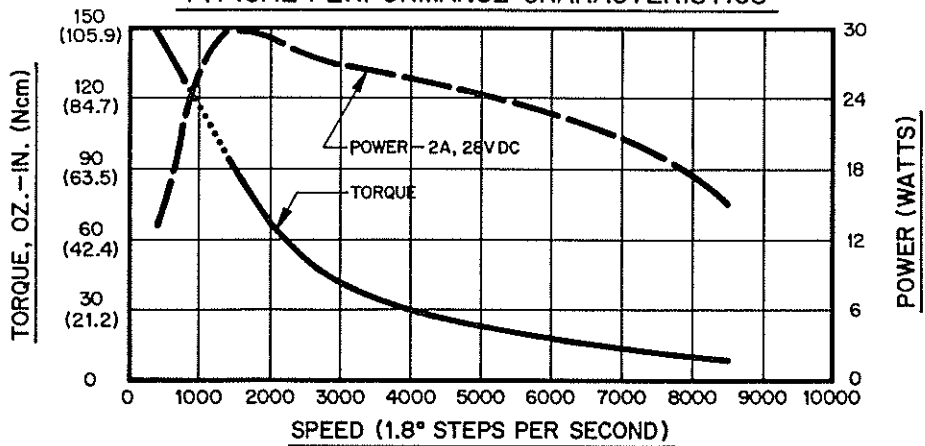

SERIES CONNECTION - M091-FC09 AND M091-FD09 MOTORS



### TYPICAL PERFORMANCE CHARACTERISTICS

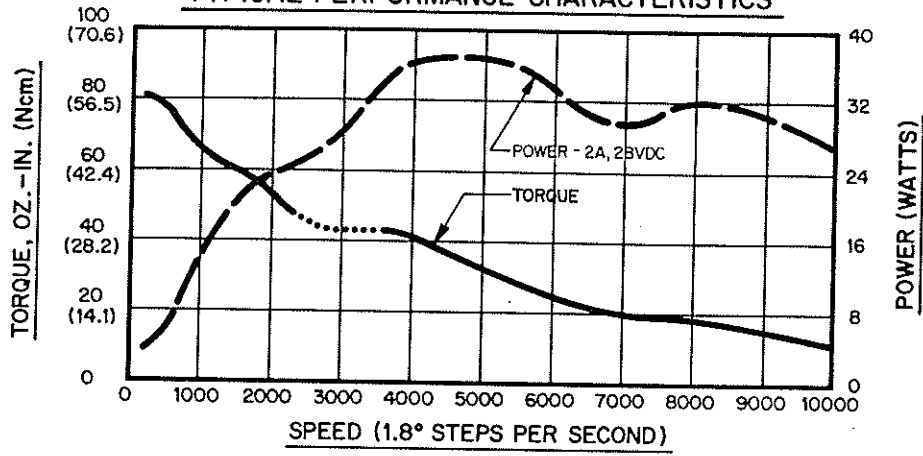

PARALLEL CONNECTION - M091-FD8009 AND M091-FD8109 MOTORS

### TYPICAL PERFORMANCE CHARACTERISTICS

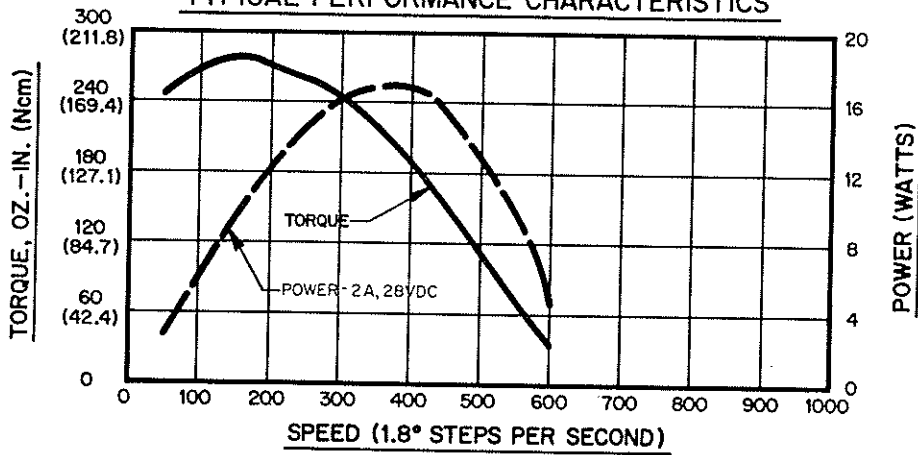

SERIES CONNECTION - M092-FC09 AND M092-FD09 MOTORS

### TYPICAL PERFORMANCE CHARACTERISTICS

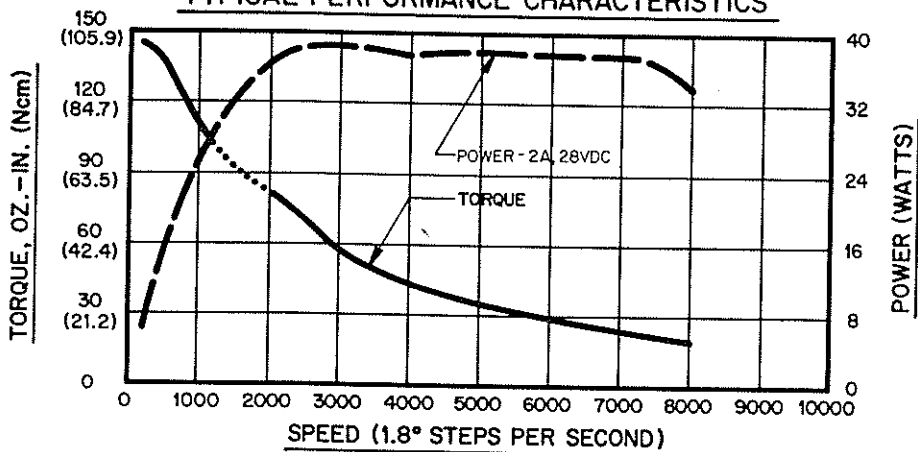

PARALLEL CONNECTION - M092-FD8109 AND M092-FD8009 MOTORS

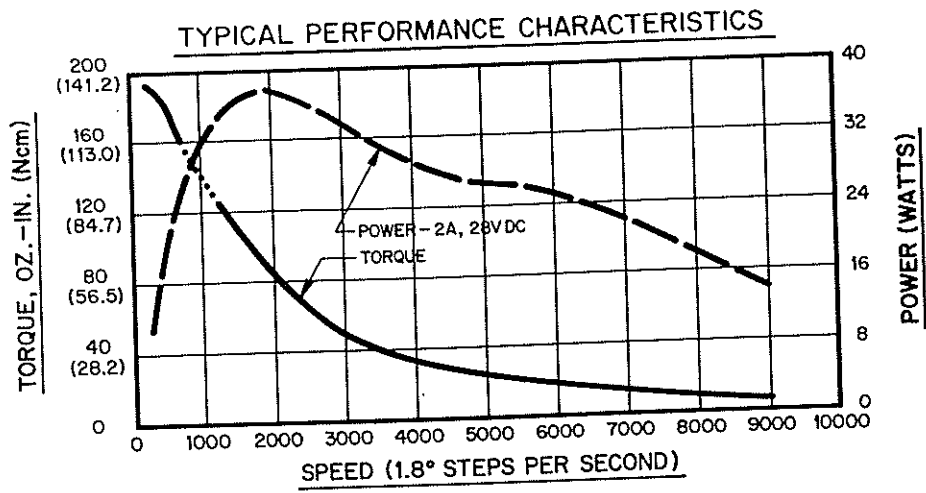

SERIES CONNECTION - M092-FD310 MOTOR

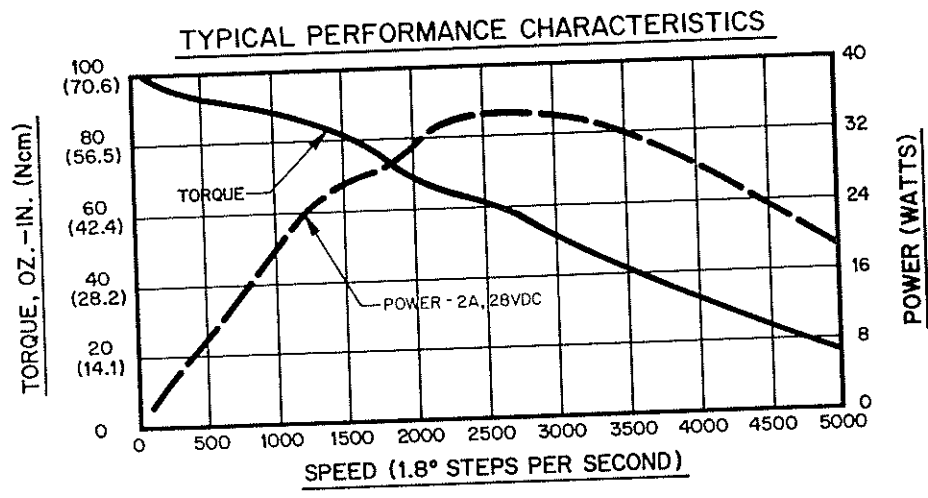

PARALLEL CONNECTION - M092-FD8814 MOTOR

# TYPICAL TORQUE VERSUS SPEED CHARACTERISTICS – 430 SERIES MOTION CONTROLS

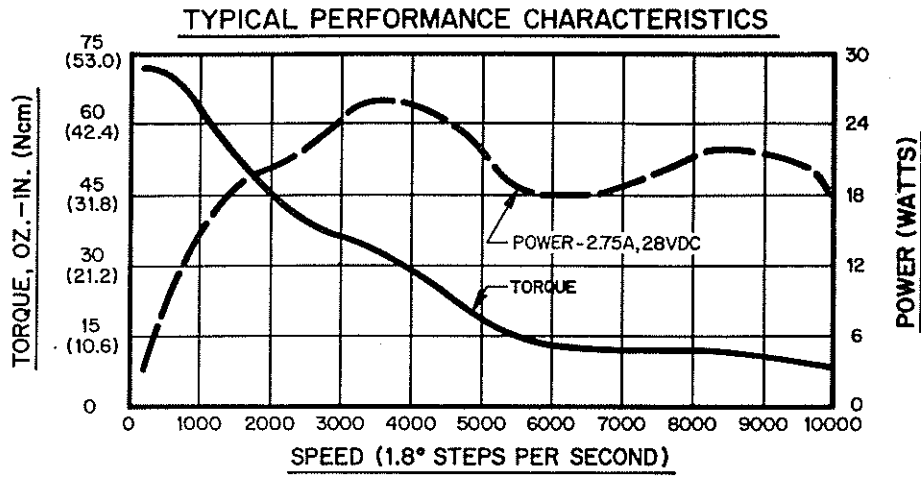

**SERIES CONNECTION – M061-CS08 AND M061-LS08 MOTORS**

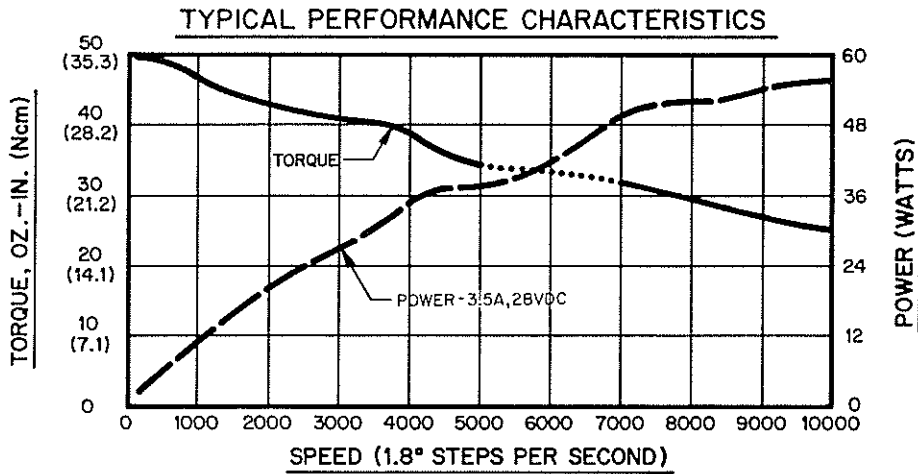

**PARALLEL CONNECTION – M061-CE08 AND M061-LE08 MOTORS**

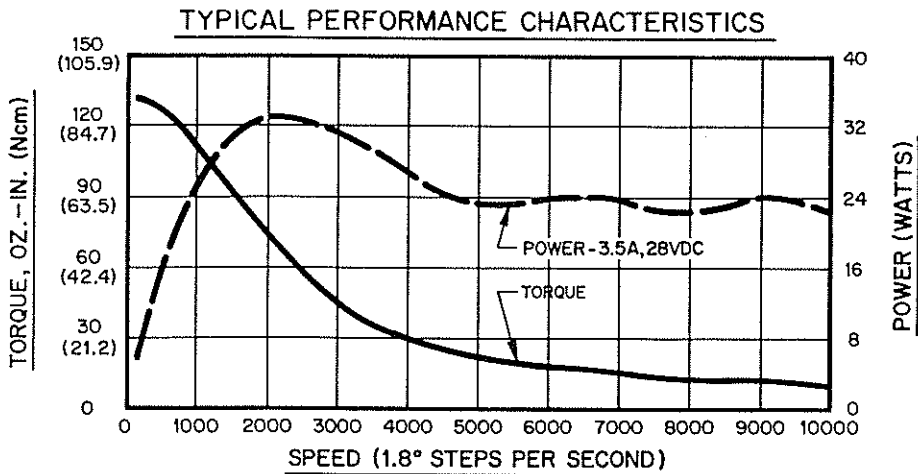

**SERIES CONNECTION – M062-CS09 AND M062-LS09 MOTORS**

TYPICAL PERFORMANCE CHARACTERISTICS

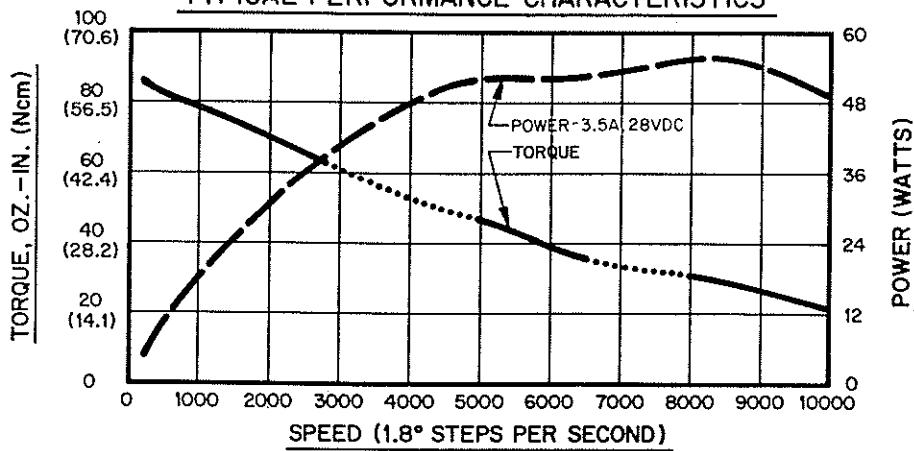

PARALLEL CONNECTION - M062-CE09 AND M062-LE09 MOTORS

TYPICAL PERFORMANCE CHARACTERISTICS

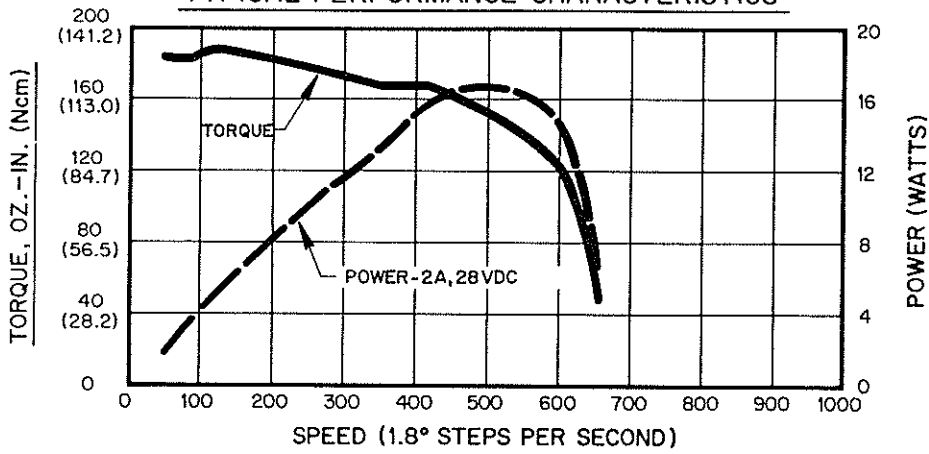

SERIES CONNECTION - M063-CS06 AND M063-LS06 MOTORS

TYPICAL PERFORMANCE CHARACTERISTICS

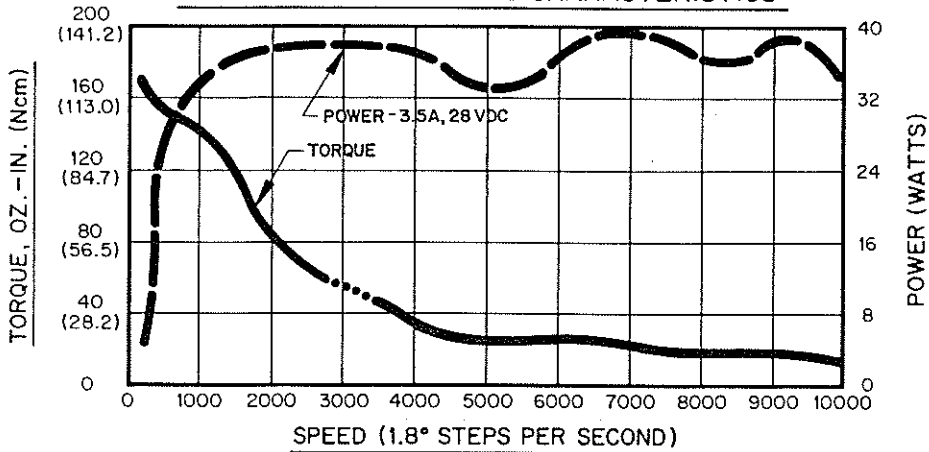

PARALLEL CONNECTION - M063-CE06 AND M063-LE06 MOTORS

TYPICAL PERFORMANCE CHARACTERISTICS

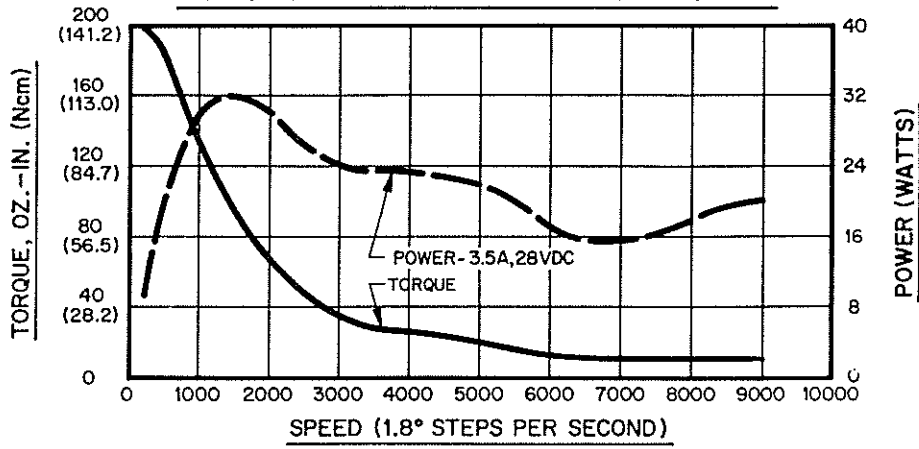

SERIES CONNECTION - M063-CS09 AND M063-LS09 MOTORS

TYPICAL PERFORMANCE CHARACTERISTICS

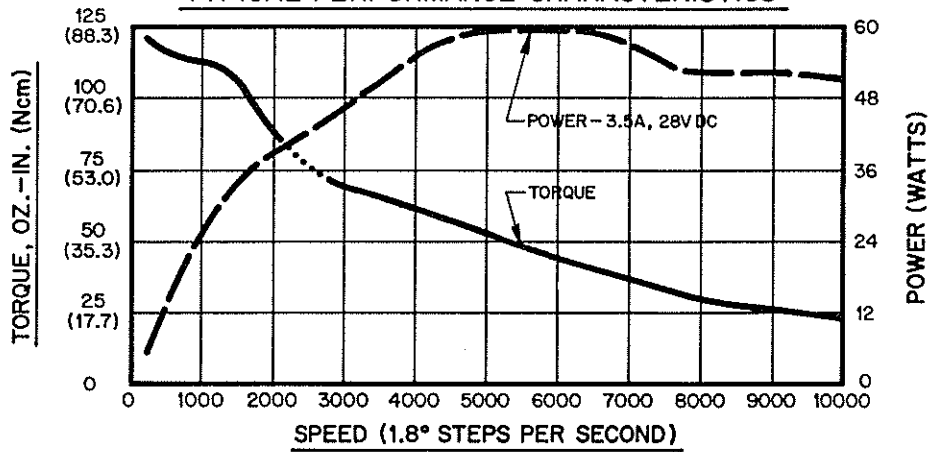

PARALLEL CONNECTION - M063-CE09 AND M063-LE09 MOTORS

TYPICAL PERFORMANCE CHARACTERISTICS

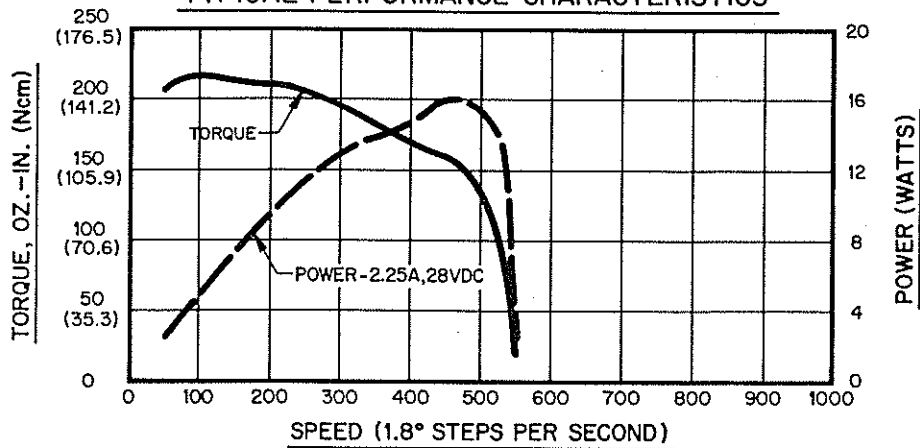

SERIES CONNECTION - M091-FC06 AND M091-FD06 MOTORS

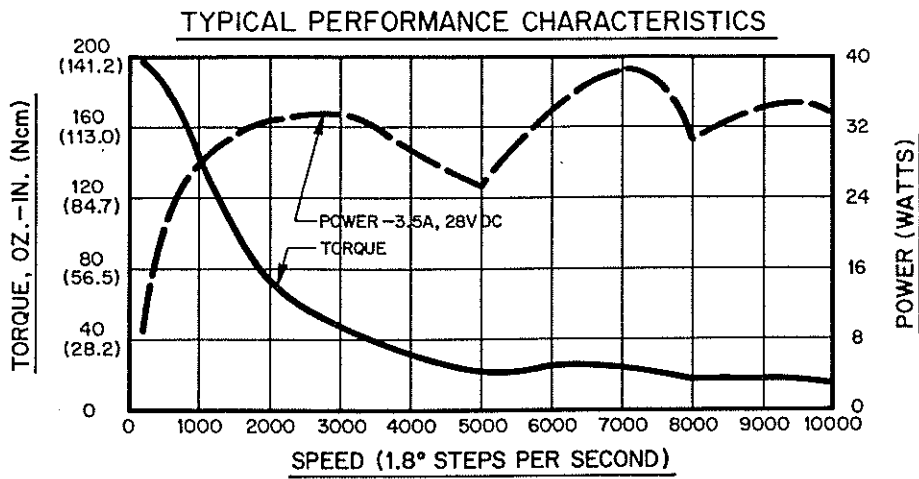

**PARALLEL CONNECTION - M091-FD8106 MOTOR**

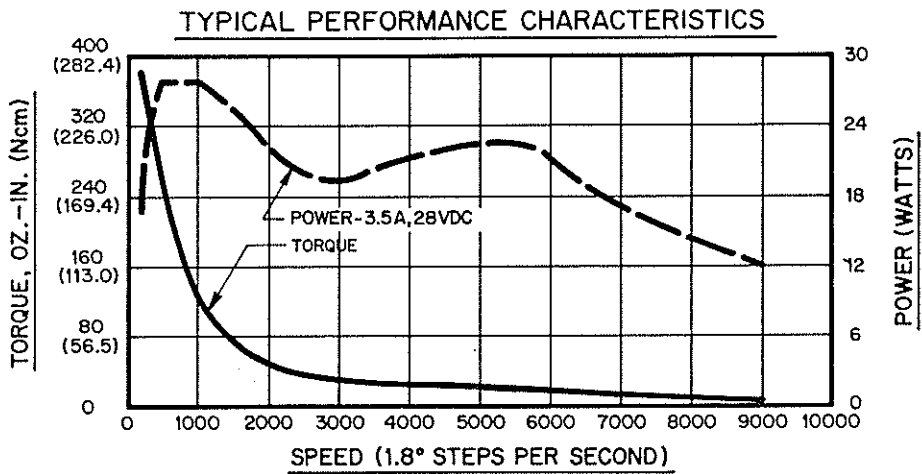

**SERIES CONNECTION - M092-FC09 AND M092-FD09 MOTORS**

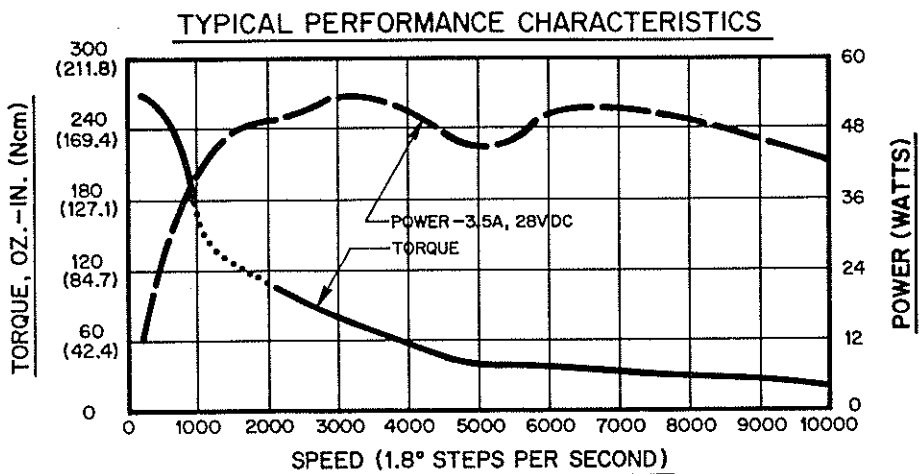

**PARALLEL CONNECTION - M092-FD8109 AND M092-FD8009 MOTORS**

TYPICAL PERFORMANCE CHARACTERISTICS

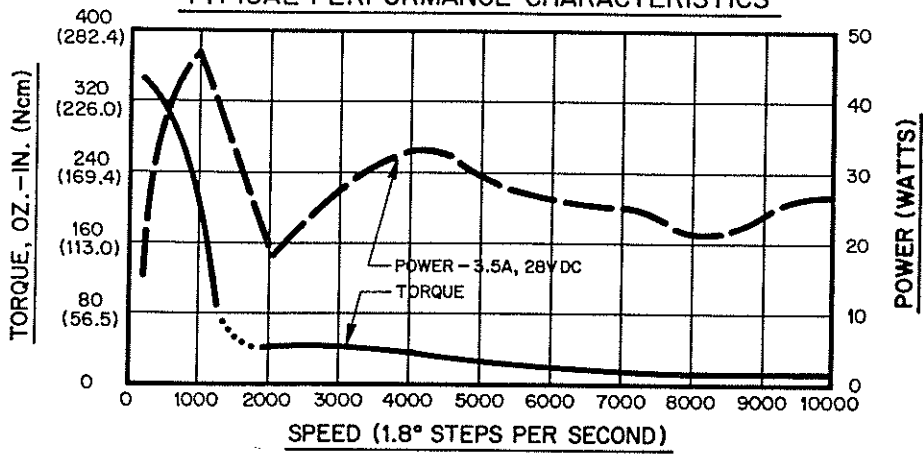

SERIES CONNECTION - M092-FD310 MOTOR

TYPICAL PERFORMANCE CHARACTERISTICS

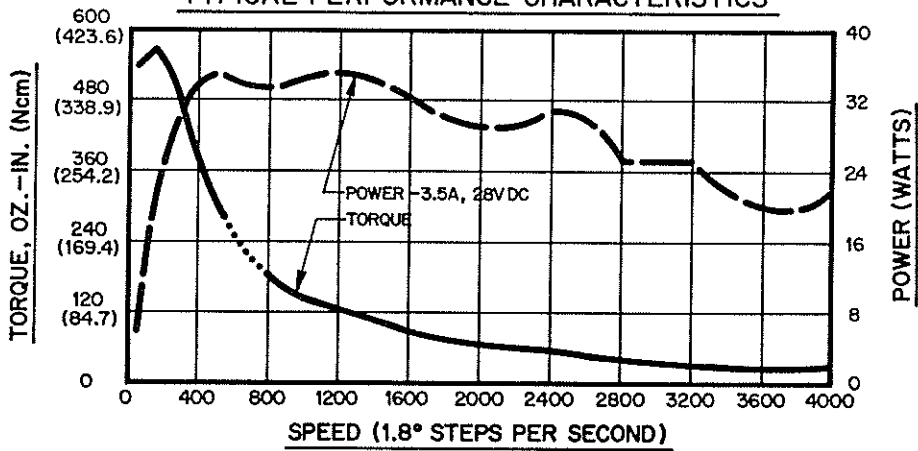

SERIES CONNECTION - M093-FD8011 MOTOR

TYPICAL PERFORMANCE CHARACTERISTICS

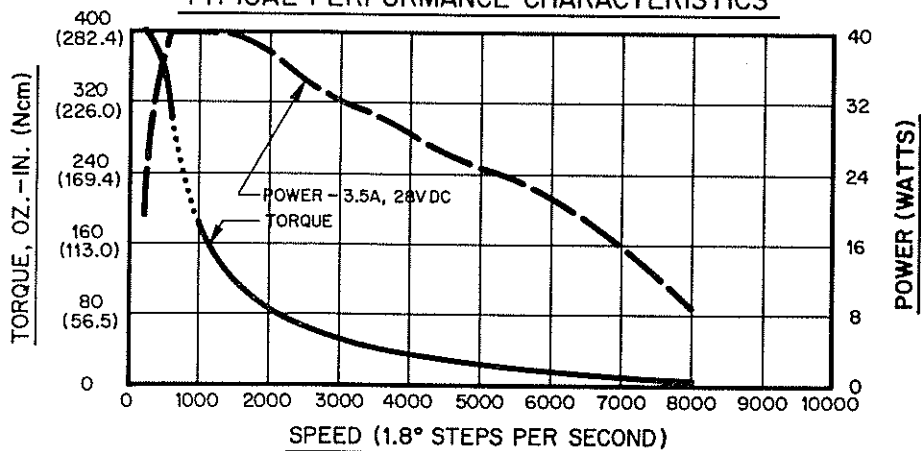

SERIES CONNECTION - M093-FC14 AND M093-FD14 MOTORS

TYPICAL PERFORMANCE CHARACTERISTICS

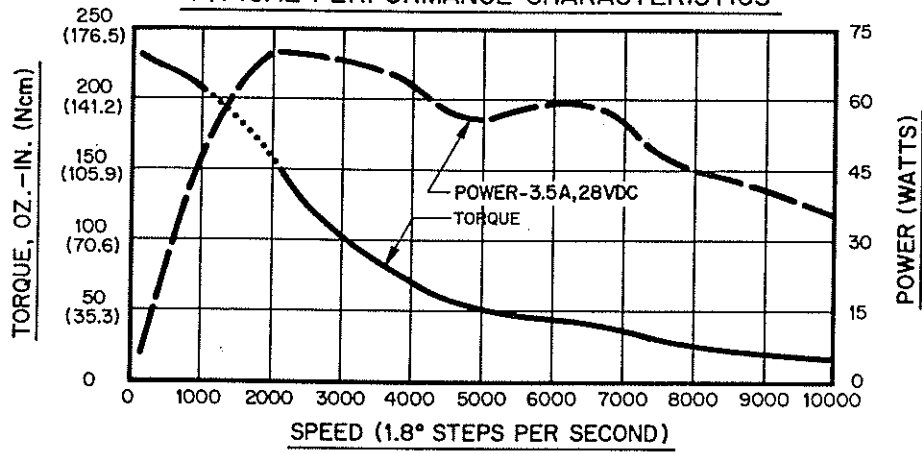

PARALLEL CONNECTION - M093-FD8014 MOTOR

TYPICAL PERFORMANCE CHARACTERISTICS

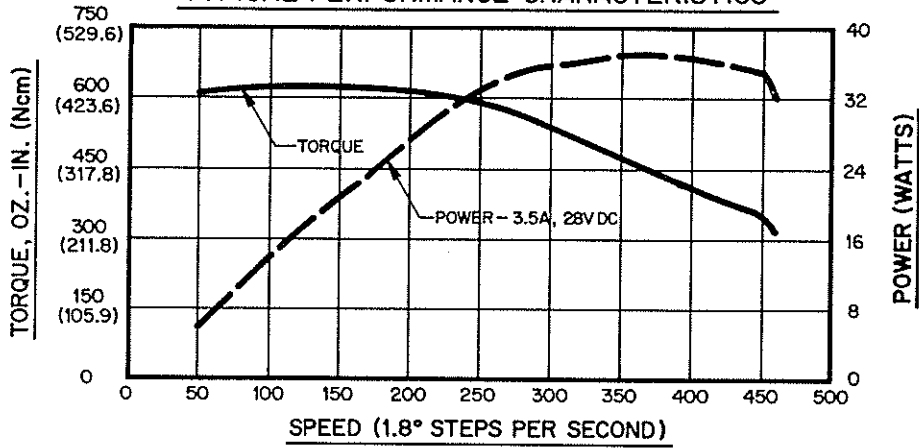

SERIES CONNECTION - M111-FD12 MOTOR

TYPICAL PERFORMANCE CHARACTERISTICS

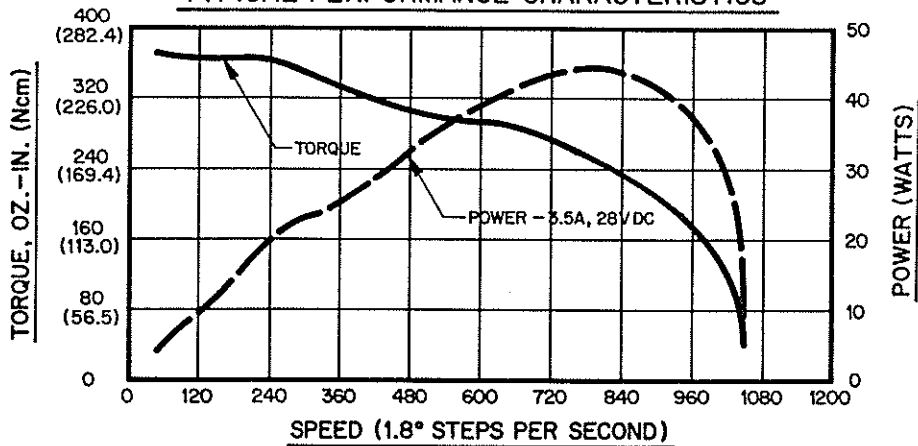

PARALLEL CONNECTION - M111-FD8012 MOTOR



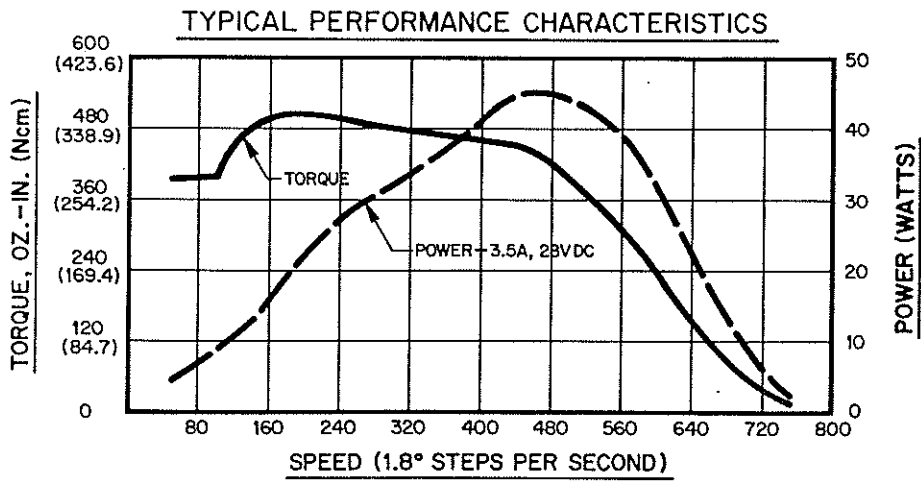

**SERIES CONNECTION - M111-FD16 MOTOR**

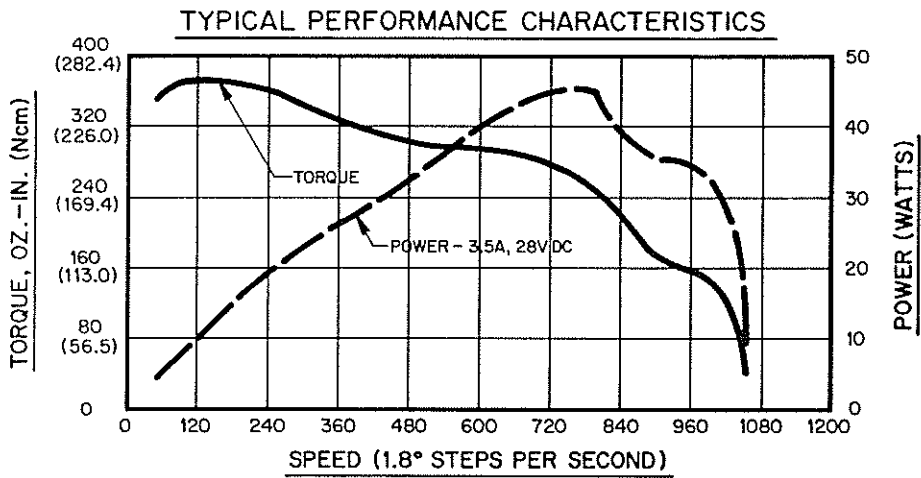

**PARALLEL CONNECTION - M112-FD8012 AND M112-FJ801 MOTORS**

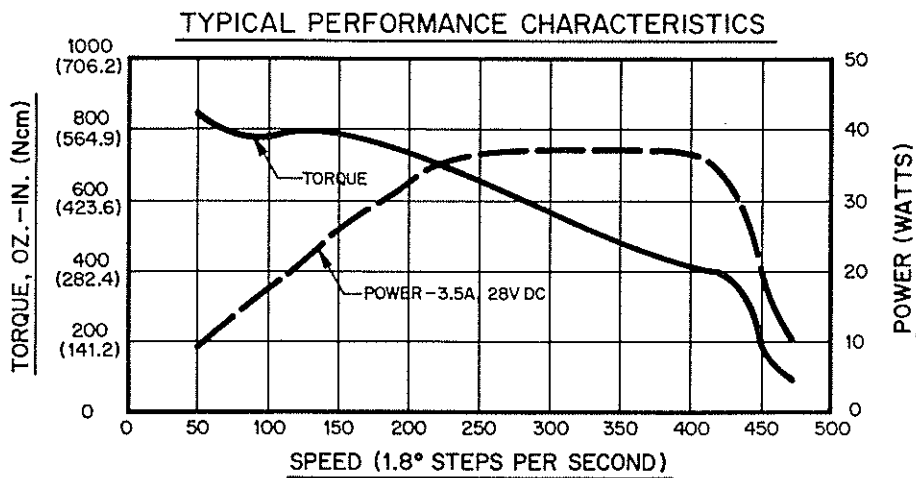

**SERIES CONNECTION - M112-FJ327 MOTOR**

TYPICAL PERFORMANCE CHARACTERISTICS

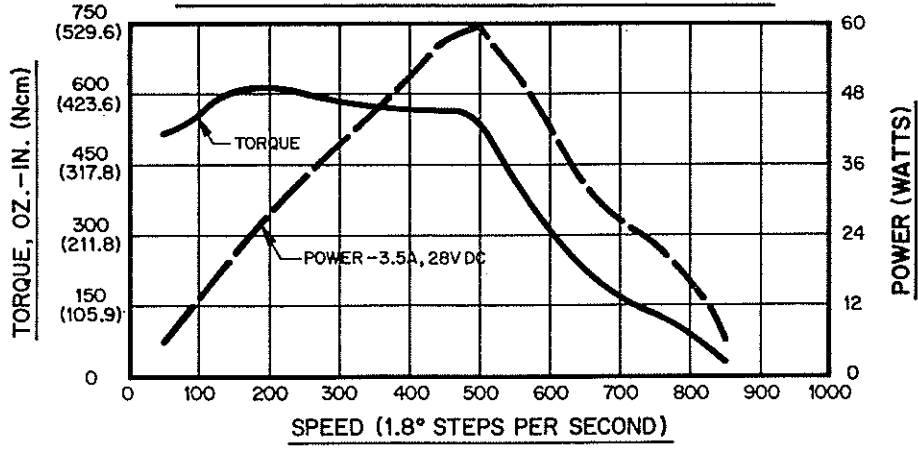

SERIES CONNECTION - M112-FJ8030 MOTOR

TYPICAL PERFORMANCE CHARACTERISTICS

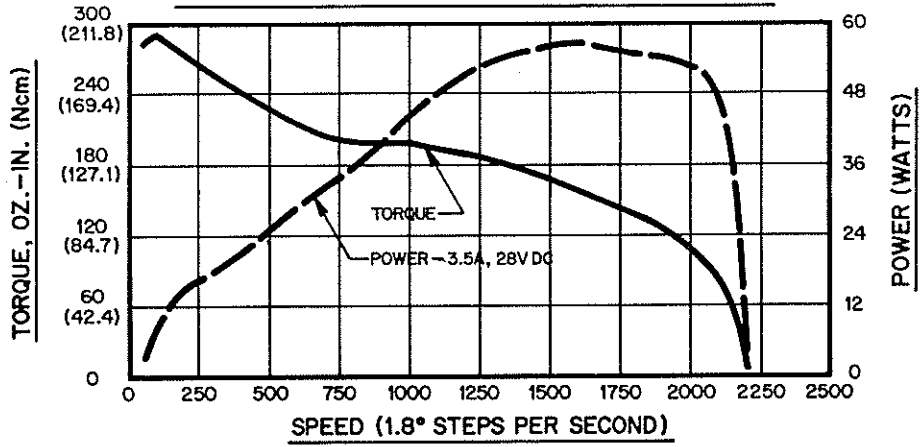

PARALLEL CONNECTION - M112-FJ8030 MOTOR

## SECTION 6: TROUBLESHOOTING

### WARNING:

Motors connected to this drive can develop high torque and large amounts of mechanical energy.

Keep clear of the motor shaft and all parts mechanically linked to the motor shaft.

Turn off all power to the drive before performing work on parts mechanically coupled to the motor.

If installation and operating instructions have been followed carefully, this unit should perform correctly. If the motor fails to step properly, the following checklist will be helpful in locating and correcting the problem.

### In General:

- Check all installation wiring carefully for wiring errors or poor connections.
- Check to see that the proper voltage levels are being supplied to the unit.
- Be sure that the motor is a correct model for use with this unit.

### Specifically:

#### IF MOTOR DIRECTION (CW, CCW) IS REVERSED, Check For:

Reversed connections to the Motor Connector.

#### IF THE MOTOR MOTION IS ERRATIC, Check For:

Supply voltage out of tolerance.

Proper motion parameters (low speed, acceleration/deceleration, jog speed, home speed and feed rate).

Operation in dotted area of speed-torque curve.

#### IF TORQUE IS LOW, Check For:

All Windings Off active or Reduced Current active

Improper supply voltage.

Operation in dotted area of speed-torque curve.

If a malfunction occurs that cannot be corrected by making the preceding checks, contact The Superior Electric Company.

---

## APPENDIX A: TROUBLESHOOTING ELECTRICAL INTERFERENCE PROBLEMS

Electrical interference problems are common with today's computer-based controls, and such problems are often difficult to diagnose and cure. If such a problem occurs with your system, it is recommended that the following checks be made to locate the cause of the problem.

1. Check the quality of the ac line voltage using an oscilloscope and a line monitor, such as the Superior Electric VMS series. If line voltage problems exist, use appropriate line conditioning, such as line filters or isolation transformers.
2. Be certain all of the recommended wiring practices are followed for location, grounding, wiring and relay suppression (see Section 3.1).
3. Double check the grounding connections to be sure they are good electrical connections and are as short and direct as possible.
4. Try operating the drive with all suspected noise sources switched off. If the drive functions properly, switch the noise sources on again, one at a time, and try to isolate which ones are causing the interference problems. When a noise source is located, try rerouting wiring, suppressing relays or other measures to eliminate the problem.

## DISTRIBUTION COAST-TO-COAST AND INTERNATIONAL

Superior Electric products are available nationwide through an extensive authorized distributor network. These distributors offer literature, technical assistance and a wide range of models off the shelf for fastest possible delivery.

In addition, Superior Electric sales engineers and manufacturers' representatives are conveniently located to provide prompt attention to customers' needs. Call the nearest office listed for ordering and application information or for the address of the closest authorized distributor.

### BRISTOL

383 Middle Street  
Bristol, CT 06010  
Tel: (203) 582-9561  
TWX: 710-454-0682  
FAX: 203-589-2136

### IN EUROPE

Superior Electric Nederland B.V.  
Koperwerf 33  
2544 EM The Hague, Netherlands  
Tel: 31 70 3 679590  
TELEX: 31436 Supe nl  
FAX: 011 31 70 296274

### IN CANADA

The American Superior Electric  
Company, Ltd.  
1815 Ironstone Manor Apt. 13  
Pickering, Ontario  
Canada L1W 3W9  
Tel: (416) 420-5988  
FAX: (416) 420-5942

### WARRANTY AND LIMITATION OF LIABILITY

Superior Electric (the "Company"), Bristol, Connecticut, warrants to the first end user purchaser (the "purchaser") of equipment manufactured by the Company that such equipment, if new, unused and in original unopened cartons at the time of purchase, will be free from defects in material and workmanship under normal use and service for a period of one year from date of shipment from the Company's factory or a warehouse of the Company in the event that the equipment is purchased from the Company or for a period of one year from the date of shipment from the business establishment of an authorized distributor of the Company in the event that the equipment is purchased from an authorized distributor.

THE COMPANY'S OBLIGATION UNDER THIS WARRANTY SHALL BE STRICTLY AND EXCLUSIVELY LIMITED TO REPAIRING OR REPLACING, AT THE FACTORY OR A SERVICE CENTER OF THE COMPANY, ANY SUCH EQUIPMENT OR PARTS THEREOF WHICH AN AUTHORIZED REPRESENTATIVE OF THE COMPANY FINDS TO BE DEFECTIVE IN MATERIAL OR WORKMANSHIP UNDER NORMAL USE AND SERVICE WITHIN SUCH PERIOD OF ONE YEAR. THE COMPANY RESERVES THE RIGHT TO SATISFY SUCH OBLIGATION IN FULL BY REFUNDING THE FULL PURCHASE PRICE OF ANY SUCH DEFECTIVE EQUIPMENT. This warranty does not apply to any equipment which has been tampered with or altered in any way, which has been improperly installed or which has been subject to misuse, neglect or accident.

THE FOREGOING WARRANTY IS IN LIEU OF ANY OTHER WARRANTIES, EXPRESS OR IMPLIED, INCLUDING, WITHOUT LIMITATION, ANY IMPLIED WARRANTY OF MERCHANTABILITY OR FITNESS FOR A PARTICULAR PURPOSE, and of any other obligations or liabilities on the part of the Company; and no person is authorized to assume for the Company any other liability with respect to equipment manufactured by the Company. The Company shall have no liability with respect to equipment not of its manufacture. **THE COMPANY SHALL HAVE NO LIABILITY WHATSOEVER IN ANY EVENT FOR PAYMENT OF ANY INCIDENTAL OR CONSEQUENTIAL DAMAGES, INCLUDING, WITHOUT LIMITATION, DAMAGES FOR INJURY TO ANY PERSON OR PROPERTY.**

Written authorization to return any equipment or parts thereof must be obtained from the Company. The Company shall not be responsible for any transportation charges.

IF FOR ANY REASON ANY OF THE FOREGOING PROVISIONS SHALL BE INEFFECTIVE, THE COMPANY'S LIABILITY FOR DAMAGES ARISING OUT OF ITS MANUFACTURE OR SALE OF EQUIPMENT, OR USE THEREOF, WHETHER SUCH LIABILITY IS BASED ON WARRANTY, CONTRACT, NEGLIGENCE, STRICT LIABILITY IN TORT OR OTHERWISE, SHALL NOT IN ANY EVENT EXCEED THE FULL PURCHASE PRICE OF SUCH EQUIPMENT.

Any action against the Company based upon any liability or obligation arising hereunder or under any law applicable to the sale of equipment, or the use thereof, must be commenced within one year after the cause of such action arises.

These products are sold subject to the standard Limitation of Liability and/or Warranty of The Superior Electric Company, The American Superior Electric Company, Ltd., or Superior Electric Nederland B.V.

The right to make engineering refinements on all products is reserved. Dimensions and other details are subject to change.



# Superior Electric

® Bristol, Connecticut 06010-7488 

TEL: (203) 582-9561 TELEX: 96-2446 TWX: 710-454-0682  
Cable Address: SUPELEC FAX: (203) 589-2136