

**INSTRUCTIONS  
FOR  
SUPERIOR SLO-SYN  
TD SERIES  
BRUSHLESS SERVO  
DRIVES**

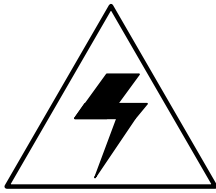



**Warning**

Dangerous voltages, currents, temperatures, and energy levels exist within this unit, on certain accessible terminals, and in the servo motor(s) and motor wiring. Caution should be exercised when installing and applying this product. Only qualified personnel should attempt to utilize, install or operate this product. It is essential that proper electrical practices, applicable electrical codes, and the contents of this manual be followed.



**Caution**

Servo motors develop high torque and speed. Precautionary measures should be used prior to performing any mechanical work or applying power to the unit. Proper preparations should be made ie. installation of limit switches, use of Following Error (in the Servo controller), power removal guards, etc. to avoid injury due to motor run away, motor oscillations, improper servo loop gains, etc..



**Caution**

Servo motors can have temperatures of up to or exceeding 100°C. Use caution when handling the motors. Where appropriate, guards should be used to prevent inadvertent contact with the motors.

---

---

#### ENGINEERING CHANGES

Superior Electric reserves the right to make engineering refinements on all its products. Such refinements may affect information given in instructions, Therefore, **USE ONLY THE INSTRUCTIONS THAT ARE PACKED WITH THE PRODUCT.**

©Superior Electric 1997

# Table Of Contents

<b><u>SECTIONS &amp; TITLE</u></b>	<b><u>PAGE</u></b>
Things to Know Before Using This Equipment	ii
1.0 - Introduction	1
1.1 - Using This Manual	1
1.2 - Product Features	
2.0 - Specifications	2
2.1 - Mechanical and Environmental Specifications	2
2.2 - Electrical Specifications	2
2.3 - Signal Specifications	3
2.4 - LED Specifications	4
2.5 - Current Specifications	5
2.6 - Motor Specifications	5
3.0 - Installation	6
3.1 - Mounting	6
3.2 - General Wiring Guidelines	7
3.3 - AC Power Wiring	9
3.4 - Motor Wiring	10
3.5 - Regenerative Resistor Connections	11
3.6 - Control Wiring	12
4.0 - Operation	13
4.1 - Introduction	13
4.2 - Initial Start-Up	13
4.3 - Sequence of Operation	13
4.4 - Protective Features	14
5.0 - Troubleshooting Guide	15
Appendix A - CE Compliance Installation Requirements and Information	17
Warranty Information	19

## **THINGS TO KNOW BEFORE GETTING STARTED**

- Only qualified personnel should install or perform service on this equipment. Do not operate the unit without the enclosure as voltage present in this unit can cause serious or fatal injuries.
- Before performing any work on this unit or the wiring, allow at least 5 minutes for the capacitors to fully discharge, to prevent electrical shock hazards.
- Motors powered by this unit develop high torque. Be sure to disconnect AC power before doing any mechanical work.
- When energizing the system, be aware that mechanical motion may occur. Be prepared to take the appropriate action to protect personnel and equipment.

# 1.0 INTRODUCTION

## 1.1 Using This Manual

It is important that you understand how TD330 units operate before installing and using these products. We strongly recommend that you read this manual completely before proceeding with the installation.

This manual is an installation and operating guide for the TD330/04 and the TD330/08 Torque Mode Amplifiers (Drives). Section 1 gives you an overview of the product functions and features. Section 2 gives detailed information on the specifications for the product and pertinent system requirements. Section 3 provides the recommended installation guidelines. Section 4 contains the recommended operating instructions for the system.

Other information included is a troubleshooting guide in Section 5, and warranty information.

## 1.2 Product Features

The TD330 drives are designed to operate hall commutation DC brushless motors. Alternatively, motors with encoders having the appropriate commutation signals may be used. The amplifier operates in the torque mode which can be connected to a positioning system such as the Superior SLO-SYN MX2000 control. A version with a built-in single-axis controller is also available as the TDC330/04 and the TDC 330/08.

- \* Line operated 115/230 Vac input
- \* Switch selectable current scaling for easy installation (no potentiometers to adjust)
- \* Latched short circuit protection (phase to phase and phase to ground)
- \* Latched over temperature protection
- \* Latched DC bus over voltage protection
- \* Optically isolated inputs
- \* 50 ohm 50 watt regenerative energy circuit included

## 2.0 SPECIFICATIONS

### 2.1 Mechanical and Environmental Specifications

Size: 2.88W x 10.63H x 8.07D (See Figure 3.1)  
Weight: TD330/04: 6.75 lbs.  
TD330/08: 7.25 lbs.

Temperature: 0°C to 50°C (32°F to 122°F) operating  
-40°C to 75°C (-40°F to 167°F) storage

Max. Heatsink Temp: 70°C (158°F); forced air cooling may be necessary

Humidity: 95% maximum, non-condensing

Altitude: 10,000 feet max.

### 2.2 Electrical Specifications

Input Voltage: Single Phase 95 to 264 Vac, 50/60 Hz

Input Current: TD330/04, 7 amps, fuse rating: **8 amp 3AB Fast Acting**  
TD330/08, 14 amps, fuse rating **15 amp 3AB Fast Acting**

Internal Bus Voltage: 130 to 375 Vdc depending on AC Input Voltage

Motor Current: TD330/04, 4 amps continuous, 8 amps peak  
TD330/08, 8 amps continuous, 16 amps peak  
(maximum value of a 6-step waveform)

Regenerative Energy Circuit: Internal: 50 ohm, 50 watt resistor  
External: Connections available  
See example for size selection in Section 3.5 or consult factory

Regenerative Energy Circuit Fusing: **1 amp 3AG Slo-Blo**

## 2.3 Signal Specifications

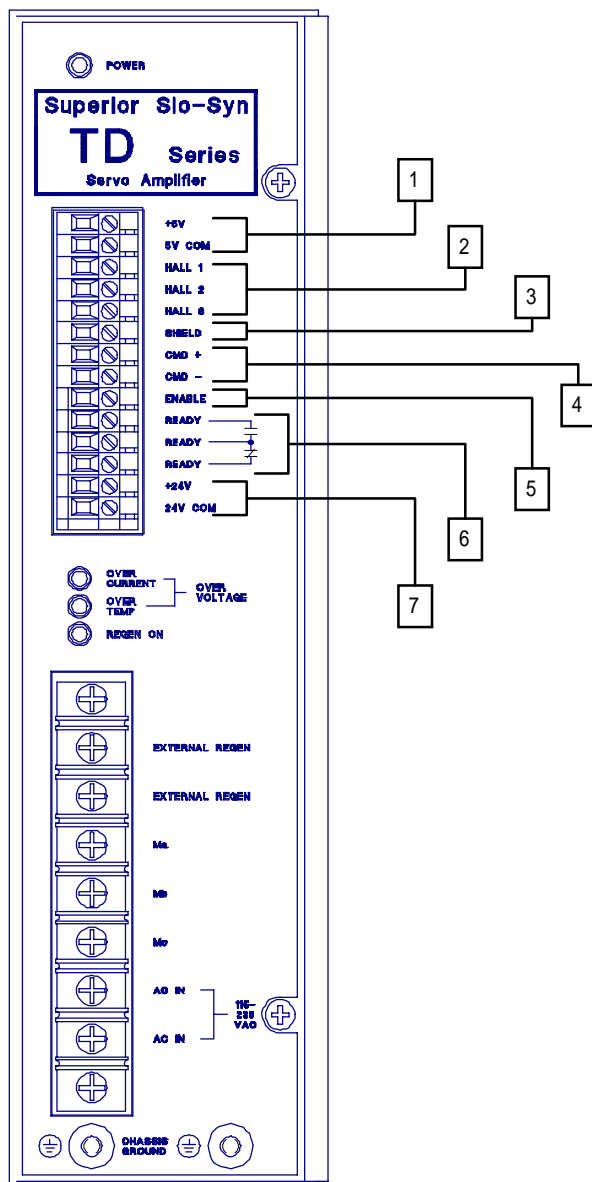

**Figure 2.1**  
**I/O Signals**

**1** **+5V and +5V COM**: 5Vdc, 0.3 amps power supply to be used for hall and/or encoder devices.

**2** **HALL 1, 2, 3**: Optically isolated inputs for the commutation devices. The inputs are pulled up to a +5 V supply through a 1000 ohm resistor. Low level current is less than 4 milliamperes. See figure 2.1 for details.

**SHIELD**: Connection to unit ground for cable shields.

**3**  
**4** **CMD+, CMD-**: The analog interface to an external controller. A voltage from +10 to -10 Volts between these two inputs commands the drive to deliver from +2X full current selected to -2X full current selected to the motor. See figure 2.1 for details.

**5** **ENABLE**: Optically isolated input which when pulled low activates the drive. The input is pulled up to the +15 V supply through a 2200 ohm resistor. The low level current is < 7 milliamps. See figure 2.1 for details.

**6** **READY**: A relay output with NO and NC contacts. The relay activates when the drive is ready. The contact current rating is 0.5 amps at 24Vdc resistive load. See figure 2.1 for details.

**7** **+24V & 24V COM**: Isolated DC supply for customer use rated 24 Vdc +/- 10% and 0.5 amps. See figure 2.1 for details.

## 2.4 LED Specifications

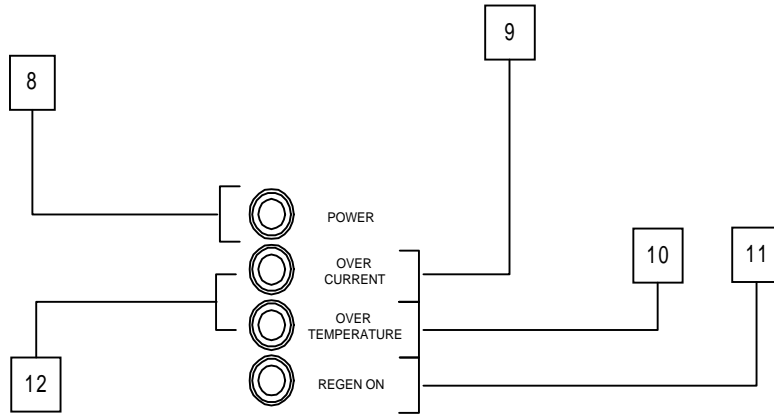

**Figure 2.2**  
**LED's**

8	Power LED:	The power LED indicates that there is AC power applied to the drive and that the logic supply is active.
9	Over Current LED:	The over current LED, when active, indicates the possibility of a short circuit from phase to ground or phase to phase. It may also be caused by a non-compatible motor being used.
10	Over temperature LED:	This LED shows that the unit has shut down due to an over temperature situation, which could be caused by the temperature of the heat sink being in excess of 70 °C (158°F) or the ambient temperature is greater than 50 °C (122°F).
11	Regen on LED:	When this LED is on the regenerative circuitry is active. <b>It does not indicate a fault.</b>
12	Over Current LED & Over temperature LED:	If the over current and the over temperature LED's are active this indicates that an over voltage condition has occurred, bus voltage > 410VDC.



## 2.5 Current Settings:

The current settings of the drive reflect the continuous current capability of the motor. Peak current is twice the continuous current setting. The TD-04 has a maximum continuous current of 4 amps and a peak current of 8 amps. The TD-08 has a maximum continuous current of 8 amps with 16 amps peak current. The highest DIP switch setting in the on position will be the max. continuous current supplied by the drive. See figure 2.3.

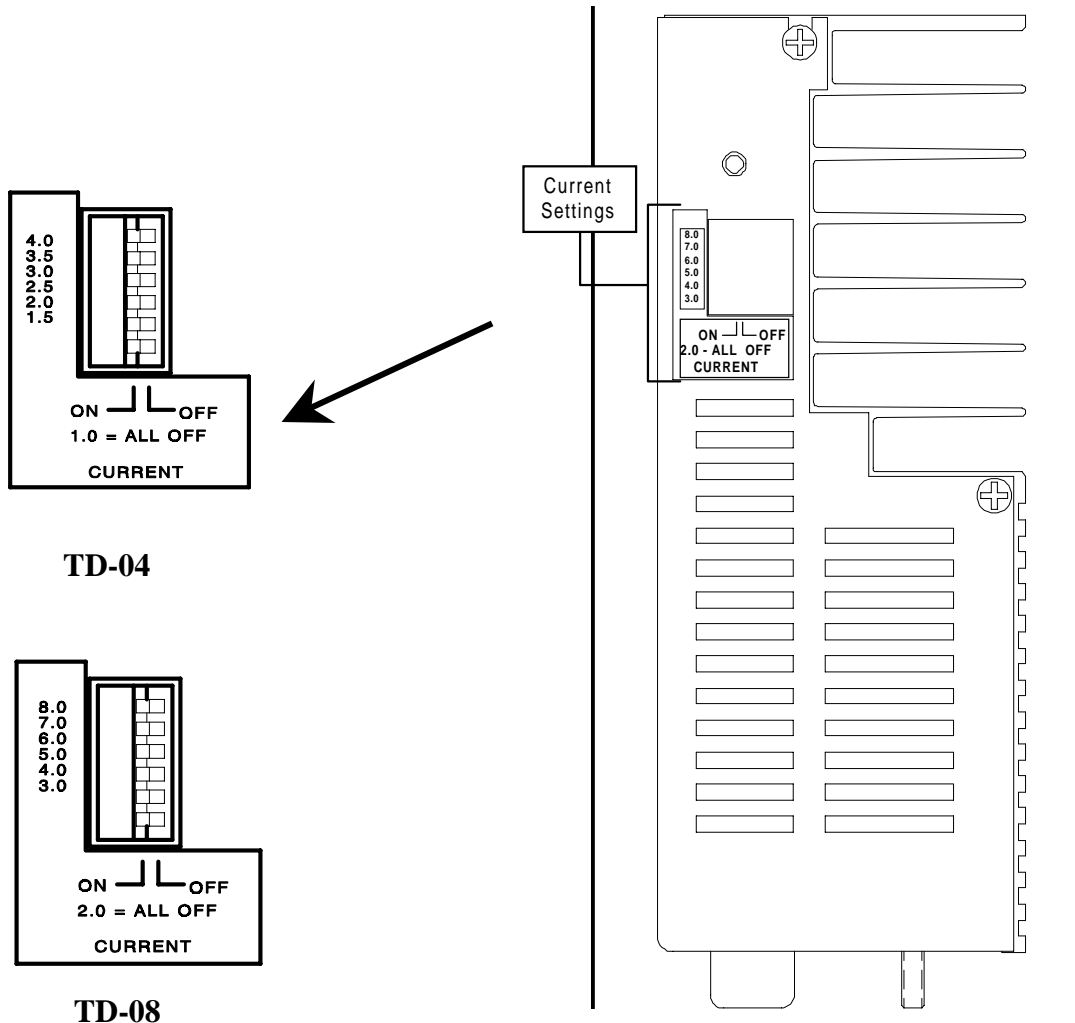

**Figure 2.3**  
**Current Settings**

## 2.6 Motor Specifications

Type:	3 Phase Brushless motor with Hall commutation or encoder with commutaion tracks
Voltage:	Capable of withstanding bus voltages of 350 Volts.
Current:	TD330/04 1 to 4 Amp continuous, 2 to 8 amp peak TD330/08 2 to 8 Amp continuous, 4 to 16 amp peak
Recommended Inductance:	4 mH minimum

**NOTE: DUTY CYCLE LIMITING WILL BE REQUIRED TO KEEP THE SHELL TEMPERATURE BELOW ITS RATING.**

### 3.0 INSTALLATION

#### 3.1 Mounting

The servo drive is intended to be mounted with the brackets supplied with the unit. When selecting a mounting location, it is important to leave at least 2 inches unrestricted space around the top, bottom, and sides of the unit to allow for proper airflow for cooling. Keep the unit away from potential noise sources or sensitive electronic equipment.

NOTE: The unit should be mounted upright with the cooling fins vertical. The case temperature should not exceed 70 °C (158 °F). Forced air cooling may be required to keep the temperature within the stated limits.

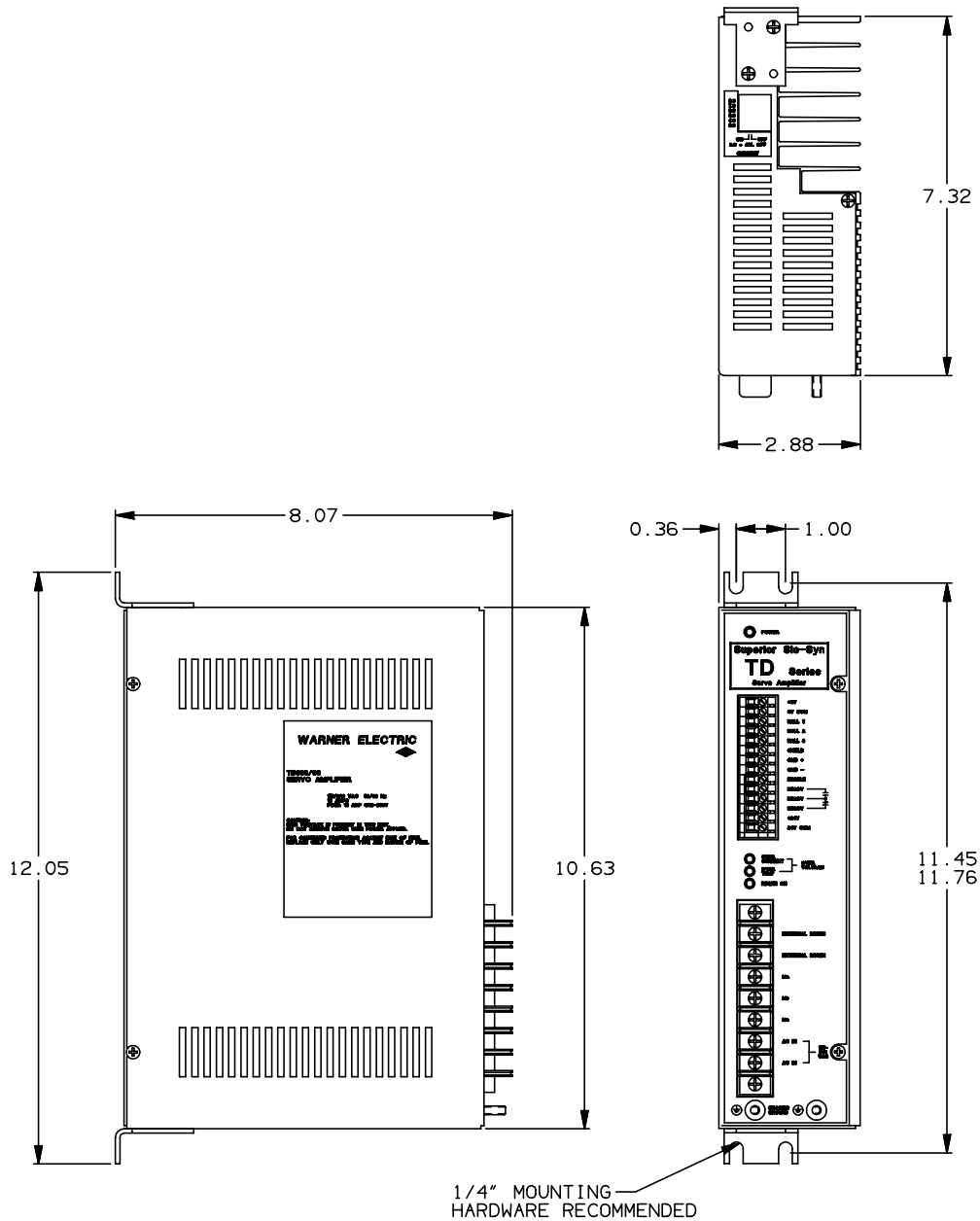

Figure 3.1  
Outline Dimensions

## 3.2 General Wiring Guidelines



**Dangerous voltages, currents, temperatures, and energy levels exist within this unit, on certain accessible terminals, and at the servo motor. NEVER operate the unit with its protective cover removed! Caution should be exercised when installing and applying this product. Only qualified personnel should attempt to install and/or operate this product. It is essential that proper electrical practices, applicable electrical codes and the contents of this manual be followed strictly.**

Superior SLO-SYN controls and drives use modern solid-state digital electronics to provide the features needed for advanced motion control applications. Although care has been taken to ensure proper operation under a wide range of conditions, some user equipment may produce considerable electromagnetic interference (EMI) which can cause inappropriate operation of the digital logic used in the control, drive, or other computer-type equipment in the user's system.

In general, any equipment that causes arcs or sparks or that switches voltage or current at high frequencies can cause interference. In addition, ac utility lines are often "polluted" with electrical noise from sources outside a user's control (such as equipment in the factory next door). Some of the more common causes of electrical interference are:

- power from the utility ac line
- relays, contactors, and solenoids
- light dimmers
- arc welders
- motors and motor starters
- induction heaters
- radio controls or transmitters
- switch-mode power supplies
- computer-based equipment
- high frequency lighting equipment
- dc servo and stepper motors and drives

**The following wiring practices should be used to reduce noise interference.**

**Solid grounding of the system is essential.** Be sure that there is a solid connection to the ac system protective earth ground (PE). Insure that there is a good electrical connection through the drive case to the control system enclosure. A separate grounding strap may be required to properly ground the unit to the control system enclosure. This strap should ideally be constructed using copper braid at least 0.5" in width.

Use a single-point grounding system for all related components of the system (a "hub and spokes" arrangement). Keep the ground connection short and direct. Grounding through **both** a mechanical connection to the control enclosure and through a grounding strap is optimal.

**Keep power and signal wiring separated.** Power wiring includes ac wiring, motor wires, etc. Signal wiring is inputs and outputs (I/O), encoder wiring, serial communications (RS232 lines), etc. If possible, use separate conduit or ducts for each. If the wires must cross, they should do so at right angles to minimize coupling.

**Use separately bundled shielded cables** for the drive to motor, encoder, serial communications, analog input, and digital I/O wiring. For motor connections, **BE SURE TO GROUND THE SHIELD AT THE SLO-SYN DRIVE END.** For other connections it is recommended that the shields be terminated at the Slo-Syn unit as well. Shield connections are provided on the unit terminal connectors for this purpose. All cable shielding should be terminated at **ONE END ONLY.** Grounding the serial communications connections at the opposite end of the controller may be necessary in some systems. If the cable shield must be connected at the opposite end from the Slo-Syn unit, the shield should **NOT** also be connected at the unit as this may cause a “ground loop” and introduce electrical noise problems.

**Suppress all relays** as close to the coil as possible to prevent noise generation. Typical suppressors are diodes, capacitors or MOV's. (See manufacturer's literature for complete information). Whenever possible, use solid-state relays instead of mechanical contact types to minimize noise generation.

In some extreme cases of interference, it may be necessary to **add external filtering** to the ac line(s) feeding the affected equipment, or to **use isolation transformers** to supply their ac power.

NOTE: Superior Electric makes a wide range of ac power line conditioners that can help solve electrical interference problems. Contact 1-800-SUP-ELEC (1-800-787-3532) for further assistance.

### 3.3 AC Power Wiring

The ac input power, 13, is connected to the 7 position terminal strip at the connection points marked AC IN and the chassis ground. The terminals are labeled as follows:

<u>Terminal</u>	<u>Neutral Connected System</u>	<u>Line to Line Connected System</u>
AC IN	Line	Line 1
AC IN	Neutral	Line 2
Chassis Ground	Ground	Ground

Note: Two chassis ground studs are provided (located near each end of the motor/AC terminal strip).

The voltage from “line” to ground in the neutral connected system, or “Line 1” and “Line 2” to ground in the line to line connected system must not exceed 264 volts ac. Refer to figure 3.2.

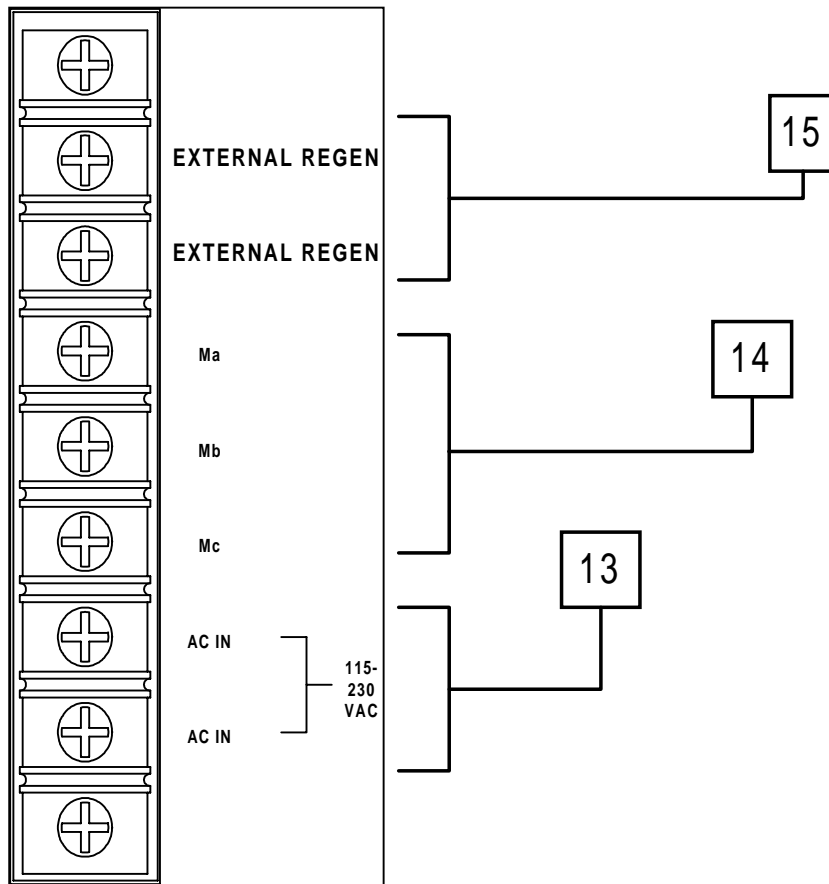

### 3.4 Motor Wiring

The motor wiring is connected to the 7 position terminal strip at the connection points marked Ma, Mb, and Mc, 14. Refer to figure 3.2. The motor ground is connected to the Chassis Ground provided. The terminals are marked as follows:

<u>Terminal</u>	<u>Connection</u>
Ma	Motor Phase A
Mb	Motor Phase B
Mc	Motor Phase C
Chassis Ground	Motor Ground

Note: Two chassis ground studs are provided (located near each end of the motor/AC terminal strip).

#### Motor & Hall Sensor Commutation Table

HALL 1	HALL 2	HALL 3	MOTOR VOLTAGE
+5 VDC	0V	0V	Ma to Mb
0V	+5VDC	0V	Mb to Mc
0V	0V	+5VDC	Mc to Ma

The above table must be used to properly “phase” your motor’s windings to the three hall effect sensors or encoder commutation tracks.

**Note:** A pull-up resistor of 1Kohm to +5VDC is provided on the three HALL inputs internal to the drive unit. If an open-collector hall sensor is used, the device must be off to yield a +5VDC signal at the drive HALL terminal.

Reference figure 3.3 for additional information.

### 3.5 Regenerative Resistor Connections

An external regenerative resistor can be connected to the 7 position terminal strip connection points marked external regen, 15. Refer to Figure 3.2. See the following example to determine if an external regenerative resistor is required.

For determining if the internal regenerative resistor is sufficient use the following formula:

**J<sub>rotor</sub>** = Inertia of the rotor in lb-in-sec<sup>2</sup>  
**J<sub>load</sub>** = Inertia of the load in lb-in-sec<sup>2</sup>  
**P** = Power of regen resistor in watts  
**N** = Speed of the motor in RPM  
**T<sub>frict</sub>** = Frictional torque in lb-in  
**t<sub>decel</sub>** = Deceleration time  
**t<sub>cyc</sub>** = Cycle time  
**E** = energy in motor in joules

$$E = \frac{1}{1616} * (J_{rotor} + J_{load}) * N^2 - \frac{1}{85} * T_{frict} * N * t_{decel}$$

$$t_{cyc} = \frac{E}{P}$$

where: **P** = Power of the internal resistor = 50 W

The internal resistor is sufficient if the calculated energy is  $\leq 200$  Joules **and** the cycle time is greater than the calculated cycle time.

Example:

**J<sub>rotor</sub>** = .0026 lb in sec<sup>2</sup>  
**J<sub>load</sub>** = 0.130 lb in sec<sup>2</sup>  
**P** = 50 W  
**N** = 4000  
**T<sub>frict</sub>** = 5 lb. in.  
**t<sub>decel</sub>** = .25 sec

$$E = \frac{1}{1616} * (.0026 + .0130) * (4000)^2 - \frac{1}{85} * 5 * 4000 * .25 = 95.63$$

$$t_{cyc} \geq \frac{95.63}{50} \geq 1.9$$

Since the energy is less than 200 joules and if the cycle time is greater than 1.9 seconds no external regen is required. If the energy is greater than 200 joules or the cycle time is less than the calculated cycle time consult the factory for the proper external regen resistor.

### 3.6 Control Wiring

The control wiring is grouped together on the terminal strip based on their origin. The hall sensor power and signals get connected to the motor. The command signals, the enable, and the ready signal typically connect to the controller. (see Figure 2.1). The 24 volt supply is for customer use and is not ground referenced. The use of shielded cable is recommended. Refer to figure 3.3 for a typical installation utilizing a MX2000 controller.

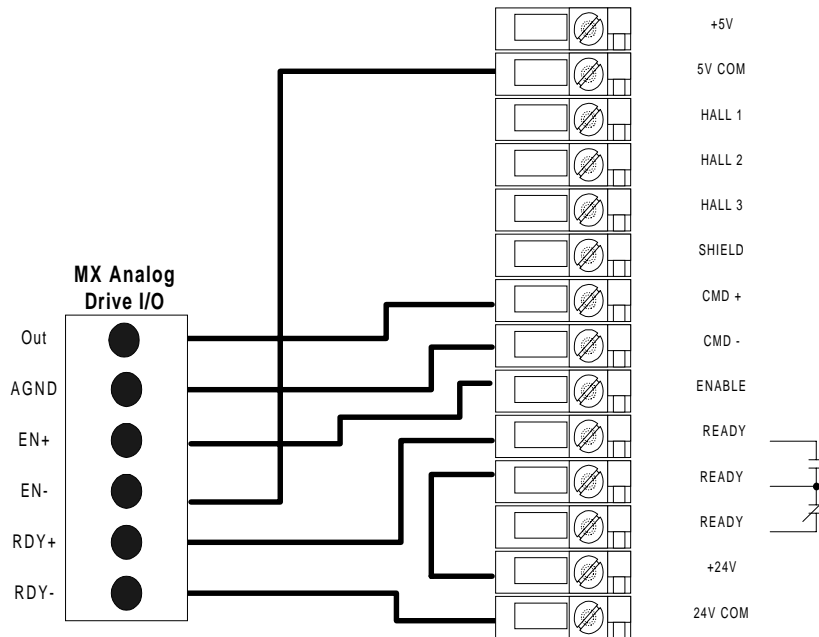

**Figure 3.3**  
**Typical Control Wiring**



## 4.0 OPERATION

### 4.1 Introduction

The TD330 series operates as a torque mode amplifier. When the drive is enabled and there are no internal shutdowns, a voltage present between the CMD inputs gets translated into motor current. This current creates torque in the motor which yields a rotational force. When connected to a motion controller such as the MX2000, the commanded voltage is issued from the MX2000. The drive's output current is scaled based on the selected dip switch setting (see Figure 2.3). The setting should be matched to the motor's specifications. Always refer to the controller manual to set up your motion control system.

### 4.2 Initial Start-Up

At this point your system should be wired including all safety devices and limit switches. The functionality of these devices **MUST** be verified before proceeding with the drive activation. Be prepared to shutdown the system in the event of servo loop problems that can include run away situations and motor oscillations.

### 4.3 Sequence of Operations

This section contains basic information for the start up of a drive and control system. Always refer to the controller manual for it's operational characteristics.

- 1) Power up the controller that is connected to the TD330 drive.



**ENSURE THAT THE FOLLOWING ERROR IS ENABLED TO PREVENT MOTOR RUN AWAY CONDITIONS, SYSTEM DAMAGE, OR INJURY.**

- 2) Verify the CMD signal to the drive is 0 volts and the enable signal is HIGH.
- 3) Power up the drive and verify the power LED is on. (There should be no motion at this time.)
- 4) Verify that there are no other drive LED's on.
- 5) Have the controller enable the drive. **BE PREPARED TO SHUTDOWN THE SYSTEM.**
- 6) If operational problems occur, refer to the troubleshooting guide contained in this manual or in the controller manual.

## **4.4 Protective Features**

### **4.4.1 AC Line Fusing**

The AC line is protected by fuses located inside the unit on the circuit card near the input terminals. Since access to the fuses requires disassembly of the unit and an open fuse would normally indicate a drive malfunction, such as a blown output IGBT, it is recommended that the unit be returned to the factory for repair.

### **4.4.2 Regen Resistor Fusing**

The regen resistor is protected by a fuse located inside the unit on the heat sink. An open fuse normally indicates a drive malfunction, such as a bad regen resistor or a failed driver transistor. Because of this fact and since access to the fuse requires disassembly of the unit, if the fuse blows, return the unit to the factory for repair.

### **4.4.3 Over Current**

The over current feature protects the unit from short circuits between the motor output terminals and between the motor output terminals and the terminals to ground. The LED will activate if either of these conditions occur. AC power must be turned off and back on to reset the drive. Ensure the LED is off and the source of the short circuit is corrected before reenergizing the drive.

### **4.4.4 Over Temperature**

The drive is protected from over temperature by utilizing a thermal switch mounted on the inside of the heat sink. When the switch temperature exceeds 70 °C (158 °F), the over temperature LED will activate. AC power must be turned off and back on to reset the drive. Fan cooling may be required to keep the drive within the temperature specifications listed in Section 2.1.

### **4.4.5 Over Voltage**

The drive has over voltage protection which will activate both LED's when the DC bus voltage exceeds 410 volts. The most likely causes for this condition are too high of a regeneration energy from the servo system or an open regen fuse. AC power must be turned off and back on to reset the drive. If the load regeneration is too high, an external regeneration resistor is required. See Section 3.5 for application details.

## 5.0 Troubleshooting Guide



**Dangerous high voltages exist in the TD330 drive products. Be certain the power has been removed for 5 minutes before any service work is performed.**

### Symptom: Power LED does not come on

1. Verify that the AC power to the unit is between 95 and 264 Vac.
2. Ensure there are no short circuits or heavy electrical loads on the +5 Vdc or +24 Vdc supplies.
3. Check for blown input fuses. Replace with same value and type listed.



**In order to provide the correct levels of protection in the unit, replacement fuses must be the same exact style and ratings as the originals in the unit. If a fuse has been blown, return the unit to the Factory for repair.**

### Symptom: Over current LED on

1. Power down the unit until the power and over current LED's go out. Power the unit back up and see if fault goes away.
2. Check the motor wiring for short circuits to ground or phase to phase.
3. Verify the motor selected is one that is compatible with the drive.
4. Verify the current setting on the drive matches that of the motor's specification.

### Symptom: Over temperature LED on

1. Power down the unit until the power and over temperature LED's go out. Power the unit back up and see if the fault goes away;
2. Check the ambient temperature to be sure it is less than 50 °C (122 °F). If the ambient temperature is greater;
3. Check heat sink temperature to be sure it is less than 70 °C (158 °F).



**Temperature of the heatsink or the unit could be hot to the touch. Caution should be used when determining the temperature.**

### Symptom: Both the Over current and Over temperature LED's are on

1. Power down the unit until the power and over temperature LED's go out. Power the unit back up and see if fault goes away.
2. If there is an external regenerative resistor:
  - a. Insure that it is connected and connected properly.
  - b. That the values for the wattage and the resistance are correct for the unit.
3. If there is no external regenerative resistor, one may be necessary.
4. Verify that the input voltage is between 95 and 264 VAC.



**External regenerative resistors are a shock and temperature hazard. Regen resistors should be mounted and enclosed properly with safe clearances around the regen resistor enclosures. Proper ventilation must also be provided for cooling purposes.**

**Symptom: Motor operates erratically**

1. Verify the motor is compatible with the drive.
2. Verify the current setting is for the motor being utilized.
3. Refer to the controller manual to obtain the proper tuning for the system and troubleshooting of the controller.
4. Verify the motor wiring.
5. Verify the hall sensor wiring.

**Symptom: Motor does not operate at all**

1. Verify the current setting is for the motor being utilized.
2. Check the drive Ready signal to be sure that there is no fault in the drive.
3. Check that the Enable signal from the control is present.
4. Check that the command voltage is being sent to the drive.
5. Verify the control wiring to drive.
6. Verify the motor wiring.
7. Verify the hall sensor wiring.



**Incorrect motor phasing or encoder wiring could produce erratic operation, a runaway condition, or system damage. Caution should always be taken when enabling the drive.**

# Appendix A

## CE Compliance

### Installation Requirements and Information

Certain practices must be followed when installing a TD servo drive or a TDC servo drive/controller in order to meet the CE Electromagnetic Compatibility (EMC) Directive (89/336/EEC) and the Low Voltage Directive (73/23/EEC). The TD family of products are components intended for installation within other electrical systems or machines. The system or machine builder must ensure their system or end product complies with all applicable standards required for that equipment, including overall CE certification. Following these practices will help ensure (but cannot guarantee) that the machine in which these components are utilized will meet overall CE requirements.

#### Electromagnetic Compatibility Directive

In order to meet the various EMC Standards, all wiring must be done in accordance with the practices shown in Figure 1.

With the addition of a suitable ac line filter, such as Corcom part number 15ET1 (connected externally), the TD drive and TDC drive/controller meet all the applicable EMC emission and immunity standards on a “stand-alone” basis:

EN55011, Class A:	for Radiated and Conducted Emissions
IEC1000-4-3:	for RF Radiated Immunity (RFRI)
IEC1000-4-4:	for Electrical Fast Transient Immunity (EFT)
IEC1000-4-6:	for RF Conducted Immunity (RFCI)

In order to achieve full CE compliance, an additional requirement must be met:

IEC1000-4-2:	for ESD Immunity
--------------	------------------

To meet this requirement, the TD or TDC must be placed inside a metal enclosure, as shown in Figure 1.

#### Low Voltage Directive

- 1) These drives are to be operated in a pollution degree 2 environment as described in standard EN50178.
- 2) All of the control inputs and outputs are isolated from the main input power with a “basic insulation rating”; e.g., their impulse withstand voltage capability is 2.5kV (1.2 / 50 us) as referenced in EN50178. Control inputs and outputs may need another level of protection against direct contact if such protection is required by the standards governing the overall system or machine and its intended operating environment. It is the machine-builder’s responsibility to provide this protection, if needed.
- 3) For electrical safety, and to protect personnel against direct contact with live electrical parts, the terminal cover (provided with the unit) MUST be installed over the AC input, motor output, and External REGEN terminals.
- 4) All cautions and warnings listed throughout the operators manual MUST be followed to insure safe system operation.

# Figure 1: Installation for EC EMI/RFI Compliance

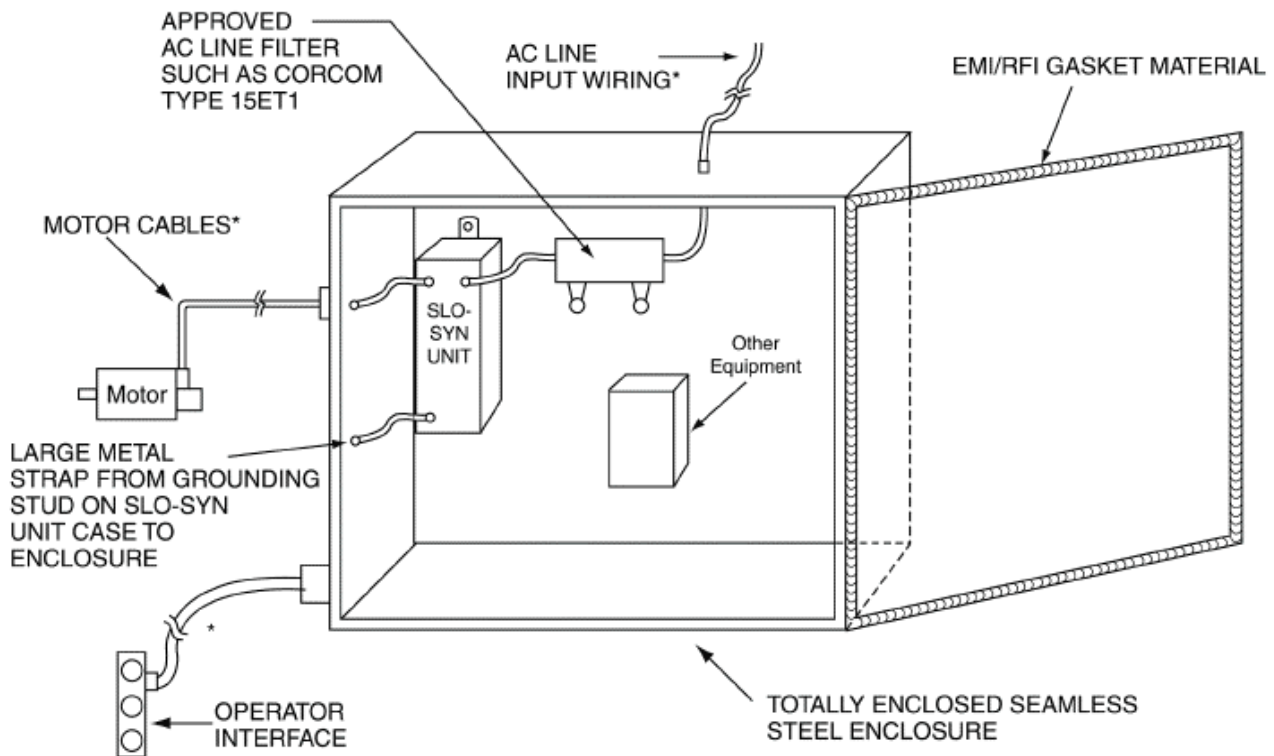

\* ALL WIRING RUNS THROUGH METAL JACKETED CONDUIT WHICH ARE ATTACHED TO ENCLOSURE WITH CLAMPS MAKING SOUND ELECTRICAL CONTACT.

## NOTES:

- 1) All metal mating surfaces within the enclosure, and any mounting plates should be cleaned of paint, anodizing and coating material for proper electrical bonding. This includes mounting of SLO-SYN unit, line filter, and any other equipment.
- 2) If mounting plates are used, proper electrical contact to the main enclosure must be maintained. Using copper straps with length-to-width ratios less than 3 is optimum.

## WARRANTY AND LIMITATION OF LIABILITY

Superior Electric (the "Company"), Bristol, Connecticut, warrants to the first end user purchaser (the "purchaser") of equipment manufactured by the Company that such equipment, if new, unused and in original unopened cartons at the time of purchase, will be free from defects in material and workmanship under normal use and service for a period of one year from date of shipment from the Company's factory or a warehouse of the Company in the event that the equipment is purchased from the Company or for a period of one year from the date of shipment from the business establishment of an authorized distributor of the Company in the event that the equipment is purchased from an authorized distributor.

**THE COMPANY'S OBLIGATION UNDER THIS WARRANTY SHALL BE STRICTLY AND EXCLUSIVELY LIMITED TO REPAIRING OR REPLACING, AT THE FACTORY OR A SERVICE CENTER OF THE COMPANY, ANY SUCH EQUIPMENT OF PARTS THEREOF WHICH AN AUTHORIZED REPRESENTATIVE OF THE COMPANY FINDS TO BE DEFECTIVE IN MATERIAL OR WORKMANSHIP UNDER NORMAL USE AND SERVICE WITHIN SUCH PERIOD OF ONE YEAR. THE COMPANY RESERVES THE RIGHT TO SATISFY SUCH OBLIGATION IN FULL BE REFUNDING THE FULL PURCHASE PRICE OF ANY SUCH DEFECTIVE EQUIPMENT.**

This warranty does not apply to any equipment which has been tampered with or altered in any way, which has been improperly installed or which has been subject to misuse, neglect or accident.

**THE FOREGOING WARRANTY IS IN LIEU OF ANY OTHER WARRANTIES, EXPRESS OR IMPLIED, INCLUDING, WITHOUT LIMITATION, ANY IMPLIED WARRANTY OF MERCHANTABILITY OR FITNESS FOR A PARTICULAR PURPOSE, and of any other obligations or liabilities on the part of the Company; and no person is authorized to assume for the Company any other liability with respect to equipment manufactured by the Company. The Company shall have no liability with respect to equipment not of its manufacture. THE COMPANY SHALL HAVE NO LIABILITY WHATSOEVER IN ANY EVENT FOR PAYMENT OF ANY INCIDENTAL OR CONSEQUENTIAL DAMAGES, INCLUDING, WITHOUT LIMITATION, DAMAGES FOR INJURY TO ANY PERSON OR PROPERTY.**

Written authorization to return any equipment or parts thereof must be obtained from the Company. The Company shall not be responsible for any transportation charges.

**IF FOR ANY REASON ANY OF THE FOREGOING PROVISIONS SHALL BE INEFFECTIVE, THE COMPANY'S LIABILITY FOR DAMAGES ARISING OUT OF ITS MANUFACTURE OR SALE OF EQUIPMENT, OR USE THEREOF, WHETHER SUCH LIABILITY IS BASED ON WARRANTY, CONTRACT, NEGLIGENCE, STRICT LIABILITY IN TORT OR OTHERWISE, SHALL NOT IN ANY EVENT EXCEED THE FULL PURCHASE PRICE OF SUCH EQUIPMENT.**

Any action against the Company based upon any liability or obligation arising hereunder or under any law applicable to the sale of equipment, or the use thereof, must be commenced within one year after the cause of such action arises.

---

The right to make engineering refinements on all products is reserved. Dimensions and other details are subject to change.

## Distribution Coast-To-Coast and International

Superior SLO-SYN products are available worldwide through an extensive authorized distributor network. These distributors offer literature, technical assistance and a wide range of models off the shelf for fastest possible delivery and service.

In addition, Superior Electric sales engineers are conveniently located to provide prompt attention to customers' needs. Call the nearest office listed for ordering and application information or for the address of the closest authorized distributor.

### In U.S.A. and Canada

383 Middle Street  
Bristol, CT 06010  
Tel: 860-585-4500  
Fax: 860-589-2136  
Customer Service: 1-800-787-3532  
Product Application: 1-800-787-3532  
Product Literature Request: 1-800-787-3532  
Fax: 1-800-766-6366

### In Europe

Warner Electric (Int.) Inc.  
La Pierreire  
CH-1029 Villars-Ste-Croix, Switzerland  
Tel: 41 21 631 33 55  
Fax: 41 21 636 07 04

---

[www.superiorelectric.com](http://www.superiorelectric.com)



383 Middle Street • Bristol, CT 06010  
(860)585-4500 • Fax:(860)589-2136

