

# Technical Description



*DEUTSCH*

**PROFIBUS - Erweiterungskarte**

*ENGLISH*

**PROFIBUS - Expansion Card**

*FRANÇAIS*

**PROFIBUS - Carte d'Expansion**

*ITALIANO*

**PROFIBUS - Scheda di Espansione**

S300 & S600 & S700 Servo Amplifiers

Edition: March 2021



For safe and proper use, follow these instructions.  
Keep them for future reference.

## Contents



Deutsch

(→ #3)



Français

(→ #7)



English

(→ #5)



Italiano

(→ #9)

### Documents available from [www.kollmorgen.com](http://www.kollmorgen.com)

- **Instructions Manual** (PDF format):  
This manual provides instructions for installation and servo amplifier setup.
- **Accessories Manual** (PDF format):  
It provides information for accessories like cables, filters, chokes and brake resistors.
- **CAN-BUS Fieldbus Interface** (PDF format):  
Describes how to use your servo amplifier in CANopen applications.
- **DeviceNET Fieldbus Interface** (PDF format):  
Describes how to use your servo amplifier in DeviceNET applications.
- **EtherCAT Fieldbus Interface** (PDF format):  
Describes how to use your servo amplifier in EtherCAT applications.
- **PROFIBUS DP Fieldbus Interface** (PDF format):  
Describes how to use your servo amplifier in PROFIBUS DP applications.
- **PROFINET Fieldbus Interface** (PDF format):  
Describes how to use your servo amplifier in PROFINET applications.
- **sercos<sup>®</sup> 2 Fieldbus Interface** (PDF format):  
Describes how to use your servo amplifier in sercos<sup>®</sup> applications.
- **SynqNet Fieldbus Interface** (PDF format):  
Describes how to use your servo amplifier in SynqNet applications.
- **DRIVEGUI.EXE Online help** (CHMs format):  
The online help includes the *ASCII Object Reference* which provides information for the parameters and commands used to setup the servo amplifier.

### Technical changes which improve the performance of the device may be made without prior notice!

This document is the intellectual property of Kollmorgen. All rights reserved. No part of this work may be reproduced in any form (by photocopying, microfilm or any other method) or stored, processed, copied or distributed by electronic means without the written permission of Kollmorgen.

# 1 Erweiterungskarte -PROFIBUS-

Dieses Kapitel beschreibt die PROFIBUS Erweiterungskarte. Informationen über den Funktionsumfang und das Softwareprotokoll finden Sie in unserem Handbuch "PROFIBUS DP Feldbus Schnittstelle".

Die PROFIBUS-Erweiterungskarte verfügt über zwei parallel verdrahtete, 9-polige Sub-D-Buchsen.

Die Spannungsversorgung der Erweiterungskarte übernimmt der Servoverstärker.

## 1.1 Frontansicht



## 1.2 Einbau

### ACHTUNG

Schalten Sie die Geräte vor Beginn der Arbeiten spannungsfrei.

### INFO

- Hebeln Sie die Abdeckung des Optionsschachtes mit einem geeigneten Schraubendreher heraus.
- Achten Sie darauf, dass keine Kleinteile (Schrauben o.ä.) in den geöffneten Optionsschacht fallen.
- Stecken Sie die Erweiterungskarte in den Schacht.
- Verschrauben Sie die Frontplatte der Erweiterungskarte mit den vorgesehenen Schrauben.

## 1.3 Anschlusstechnik

Leitungsauswahl, Leitungsführung, Schirmung, Busanschlussstecker, Busabschluss und Laufzeiten werden in den "Aufbauanleitung PROFIBUS-DP/FMS" der PROFIBUS-Nutzerorganisation PNO beschrieben.

## 1.4 Anschlussbild

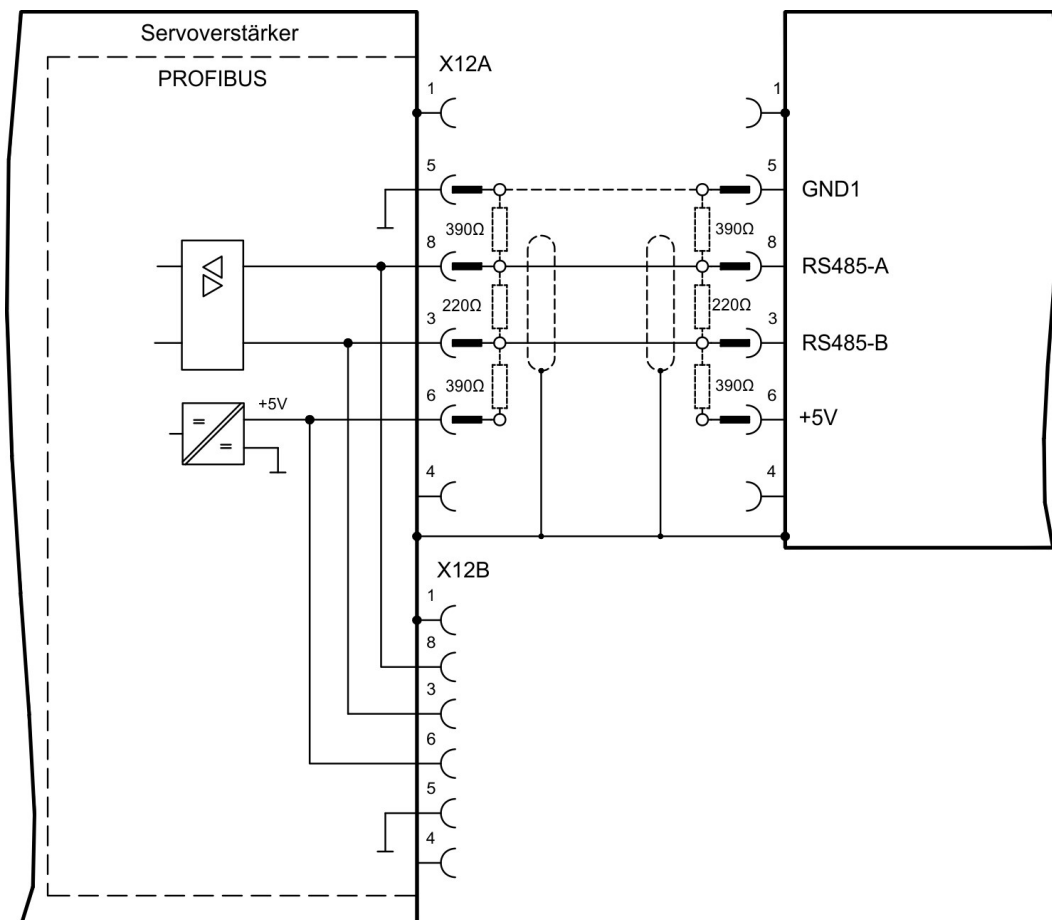

### **ACHTUNG**

Beim SERVOSTAR 600 müssen zusätzlich AGND und DGND (Stecker X3) gebrückt werden!

## 2 Expansion card -PROFIBUS-

This section describes the PROFIBUS expansion card.

Information on the range of functions and the software protocol can be found in our manual “Communication Profile PROFIBUS DP”.

The PROFIBUS expansion card has two 9-pin SubD sockets wired in parallel.

The supply voltage for the expansion card is provided by the servo amplifier.

### 2.1 Front view



### 2.2 Installation

#### **NOTICE**

Before starting work, switch off the power to the device

#### **NOTE**

- Use a suitable screwdriver to lever off the cover of the option slot.
- Take care that no small items (such as screws) fall into the open option slot.
- Push the expansion card into the slot.
- Use the screws provided to fasten the front plate of the expansion card in place.

### 2.3 Connection technology

Cable selection, cable routing, shielding, bus connector, bus termination and transmission times are all described in the “Installation Guidelines for PROFIBUS-DP/FMS” from PNO, the PROFIBUS User Organization.

## 2.4 Connection diagram

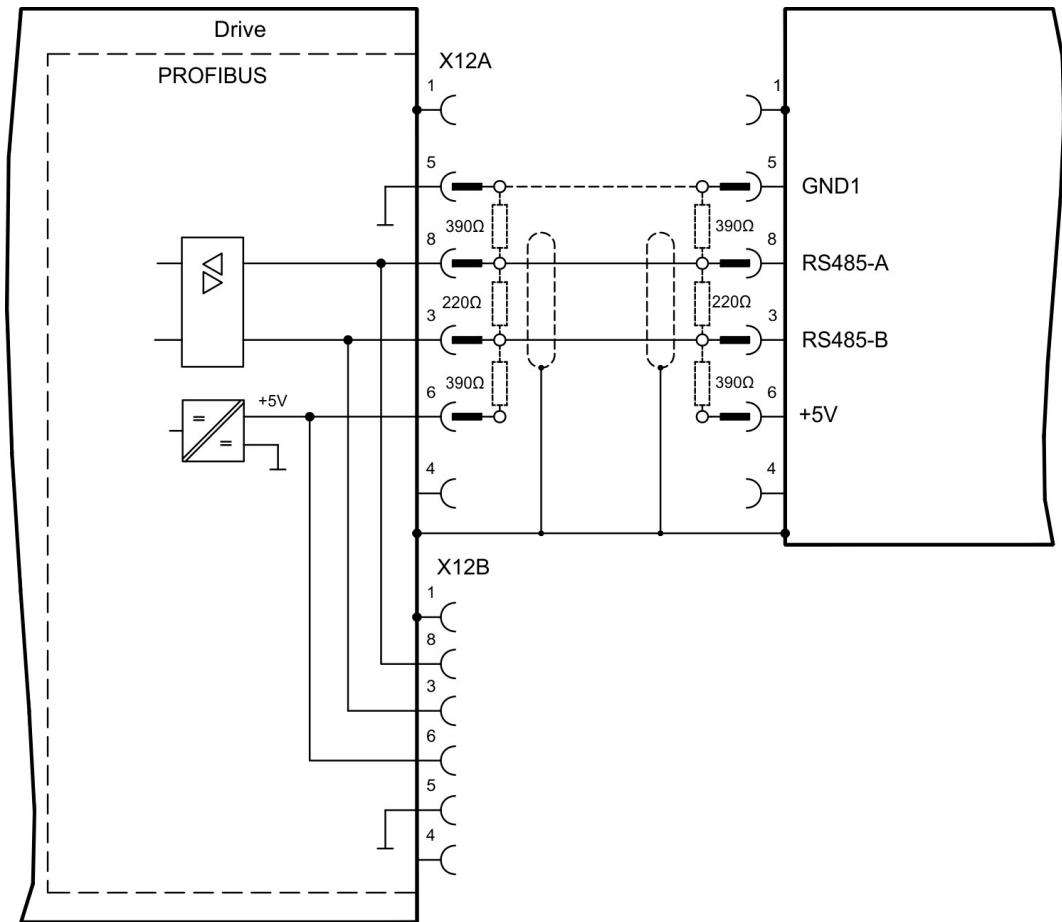

**NOTICE**

With SERVOSTAR 600 terminals AGND and DGND (connector X3) must be joined together !

### 3 Carte d'expansion -PROFIBUS-

Ce chapitre décrit la carte d'expansion PROFIBUS. Les informations relatives à l'étendue des fonctions et le protocole de logiciel figurent dans la description "Profil de communication PROFIBUS DP".

La carte d'expansion PROFIBUS possède deux connecteurs femelles Sub-D 9 pôles câblés en parallèle.

L'alimentation en tension de la carte d'expansion est assurée par le variateur.

#### 3.1 Vue de face

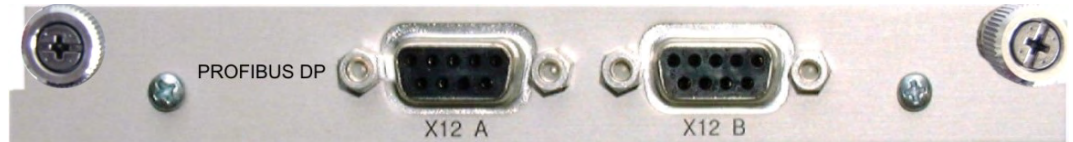

#### 3.2 Montage

##### AVIS

Avant de commencer le travail, mettez l'appareil hors tension.

##### INFORMATION

- Soulever le couvercle de l'emplacement des options à l'aide d'un tournevis approprié.
- S'assurer qu'aucune petite pièce (vis ou autres) ne chute dans l'emplacement ouvert.
- Enfichez la carte d'expansion dans le port.
- Vissez la face avant de la carte d'expansion à l'aide des vis prévues à cet effet.

#### 3.3 Technique de raccordement

Le choix des câbles, la disposition des câbles, le blindage, le connecteur de raccordement de bus, la terminaison du bus et les temps de parcours sont décrits dans les "Directives de montage PROFIBUS-DP/FMS" de l'organisation PNO des utilisateurs du PROFIBUS.

### 3.4 Schéma de raccordement

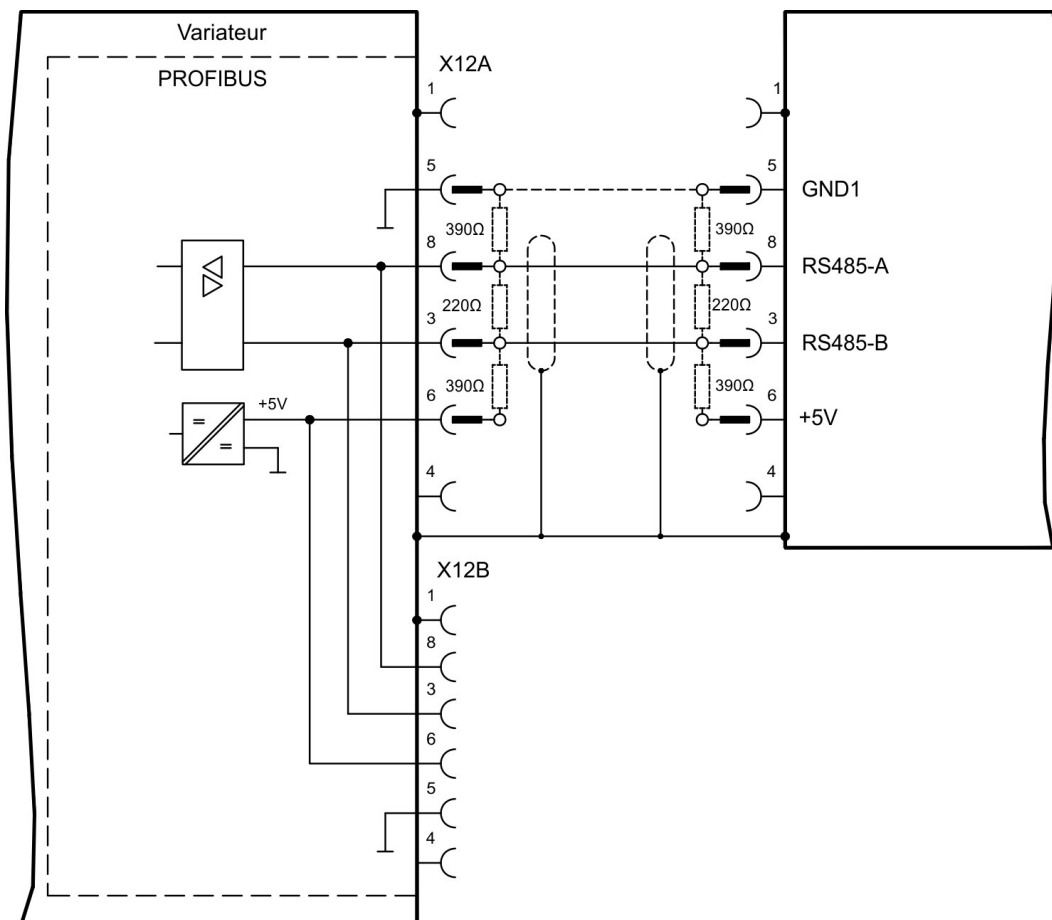

**AVIS**

Avec SERVOSTAR 600 AGND et DGND (connecteur X3) doivent être strappés !



## 4 Scheda di espansione -PROFIBUS-

PROFIBUS Questo capitolo descrive la scheda di espansione PROFIBUS. Le informazioni sul volume di funzioni e sul protocollo software si trovano nella manuale "Profilo di comunicazione PROFIBUS DP".

La scheda di espansione PROFIBUS dispone due connettori femmina Sub-D a 9 poli, cablati in parallelo. L'alimentazione della scheda di espansione avviene tramite il servovalimentatore.

### 4.1 Vista frontale



### 4.2 Montaggio

#### AVVISO

Prima di iniziare il lavoro, spegnere il dispositivo.

#### INFORMAZIONI

- Utilizzare un cacciavite adatto per rimuovere il coperchio dello slot opzionale.
- Fare attenzione che nessun piccolo oggetto (come le viti) cada nello slot opzionale aperto.
- Inserire la scheda di espansione nello slot.
- Avvitare la piastra frontale della scheda di espansione con le viti in dotazione.

### 4.3 Sistema di allacciamento

La scelta dei cavi, la conduttività dei cavi, la schermatura, il connettore di collegamento bus, la terminazione bus e i tempi d'esercizio sono descritti nelle "Indicazioni di montaggio PROFIBUS-DP/FMS" dell'Associazione degli utenti PROFIBUS PNO.

### 4.4 Schema collegamenti

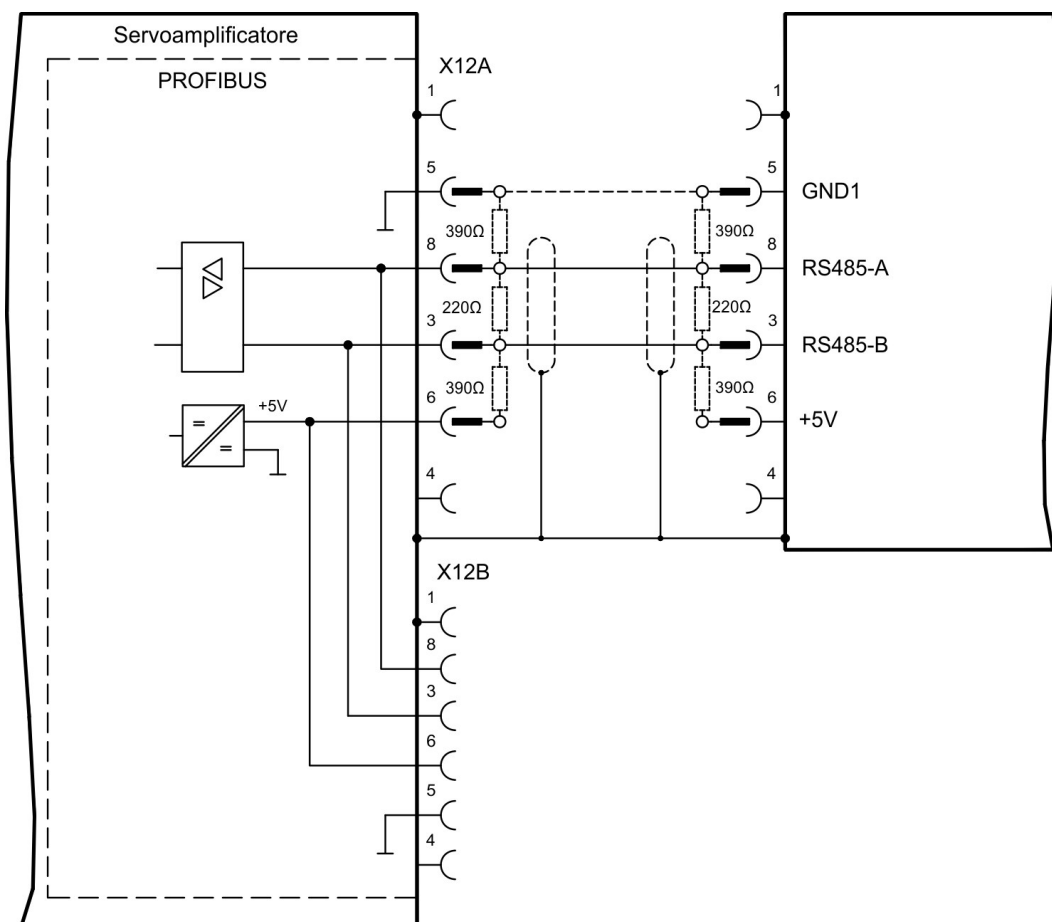

**AVVISO**

Con il SERVOSTAR 600 è necessario ponticellare anche AGND e DGND (connettore X3)!

-- / --

## Service

Kollmorgen bietet seinen Kunden einen umfassenden Kundendienst.



Besuchen Sie das [Kollmorgen Developer Network](#). Stellen Sie Fragen an die Community, durchsuchen Sie die "Knowledge Base", laden Sie Dateien herunter und schlagen Sie Verbesserungen vor.



### Europa

KOLLMORGEN

Internet: [www.kollmorgen.com/de-de](http://www.kollmorgen.com/de-de)

E-Mail: [technik@kollmorgen.com](mailto:technik@kollmorgen.com)

Tel.: +49 - 2102 - 9394 - 0

Fax: +49 - 2102 - 9394 - 3155



### Nordamerika

KOLLMORGEN

Internet: [www.kollmorgen.com/en-us](http://www.kollmorgen.com/en-us)

E-Mail: [support@kollmorgen.com](mailto:support@kollmorgen.com)

Tel.: +1 - 540 - 633 - 3545

Fax: +1 - 540 - 639 - 4162



### Südamerika

KOLLMORGEN

Internet: [www.kollmorgen.com/pt-br](http://www.kollmorgen.com/pt-br)

E-Mail: [contato@kollmorgen.com](mailto:contato@kollmorgen.com)

Tel.: +55 - 11 - 4615-6300



### Asien

KOLLMORGEN

Internet: [www.kollmorgen.cn](http://www.kollmorgen.cn)

E-Mail: [sales.china@kollmorgen.com](mailto:sales.china@kollmorgen.com)

Tel: +86 - 400 668 2802

Fax: +86 - 21 6248 5367

