



# S200-CNS Product Manual

## Hardware Installation Manual

Revision B1 May 08, 2008



Keep all product manuals as a product component during the life span of the servo amplifier. Pass all product manuals to future users/owners of the servo amplifier.



**Record of Revisions**

<b>Date</b>	<b>Issue</b>	<b>Description</b>
9/14/07	A	Separated Installation and Operation into separate manuals
11/13/07	B	Reversed Polarity of DINP10 on Schematics
05/08/08	B1	Restructured, size A4

©2006 2007 Danaher Motion - All rights reserved. Printed in the Germany.

Danaher Motion® is a registered trademark of the Danaher Corporation.

Technical changes which improve the performance of the equipment may be made without prior notice!  
All rights reserved. No part of this work may be reproduced in any form (by printing, photocopying, microfilm or any other method) or stored, processed, copied or distributed by electronic means without the written permission of Danaher Motion.

**Table of Contents**

<b>1</b>	<b>Product Documentation.....</b>	<b>5</b>
<b>2</b>	<b>Safety.....</b>	<b>6</b>
2.1	Safety Symbols.....	6
2.2	Safety Notes .....	6
<b>3</b>	<b>Product Overview .....</b>	<b>8</b>
3.1	Highlights .....	8
3.2	Increased Machine Throughput & Longer Life.....	9
3.3	Reduced Engineering & Support Time .....	9
3.4	CE- / UL- Conformity .....	9
3.5	Model Number Scheme.....	10
3.6	Valid Drive Model Numbers .....	10
<b>4</b>	<b>Specifications.....</b>	<b>11</b>
4.1	Drive Family Power .....	11
4.2	Input Power Specifications.....	13
4.3	DC Input Drives - Control and Power.....	14
4.4	Control Loop Performance.....	14
4.5	Mechanical Specifications.....	16
4.6	I/O Specifications .....	16
4.7	Environmental Specifications.....	17
4.8	Smart Feedback Device (SFD).....	18
<b>5</b>	<b>Accessories.....</b>	<b>19</b>
5.1	Cables .....	19
5.1.1	Motor and feedback cables .....	19
5.1.2	Serial Communications Cable .....	19
5.2	Connector Kits.....	20
5.2.1	Base Unit Connector Kits .....	20
5.2.2	Position Node Connector Kits .....	23
5.3	Regen Resistor.....	23
5.4	Din Rail Terminal Break Outs.....	24
5.5	Operator Interface Terminals .....	24
5.6	Systems Capabilities.....	24
<b>6</b>	<b>Installation.....</b>	<b>25</b>
6.1	Unpacking and Inspecting .....	25
6.2	Mounting .....	25
6.3	Dimensions.....	26
6.4	Mounting Outline .....	27
<b>7</b>	<b>Wiring Diagrams.....</b>	<b>28</b>
7.1	Low Power AC Drive Wiring Diagram.....	28
7.2	High Power AC Wiring Diagram .....	29
7.3	DC Models Drive Wiring Diagram .....	30
<b>8</b>	<b>Connector Pinout and DDescriptions.....</b>	<b>31</b>
8.1	PE All Drive Models .....	31
8.2	J1 – Low Power AC Input Power Models Drive Power.....	32
8.3	J1 – AC Input Control Power High Power AC Models .....	34
8.4	TB1: High Power AC Power Connections .....	35
8.5	J1 – DC Input Power Models Drive Power Connector .....	36
8.6	J2 – Motor Power Connector.....	37
8.7	J3 – SFD Feedback Connector .....	37
8.8	J4 – Command I/O Connector.....	38
8.9	J5: Serial Port Connections .....	39
8.10	J11 CAN bus Connections .....	39
8.11	J12 Connector.....	40
8.12	J13 Encoder Feedback Connector .....	41
<b>9</b>	<b>DC Input Power Model Power Supply Requirements.....</b>	<b>42</b>
9.1	Control Voltage .....	43
9.2	Grounding.....	43
9.3	Bus Capacitance .....	43
9.4	Bus Switching and Fusing.....	44

<b>10</b>	<b>Detailed Wiring Information .....</b>	<b>45</b>
10.1	Cables .....	45
10.1.1	Long Cables .....	45
10.1.2	Custom Composite Cables.....	45
10.2	Definitions Discussion.....	47
10.3	PE Earth Ground Connections.....	47
10.4	Serial port Wiring .....	48
10.5	Wiring Discrete Digital Inputs .....	48
10.6	Typical wiring with sinking switches:.....	49
10.7	Typical Wiring with Sourcing Switches.....	50
10.8	Wiring DINP5 and DINP10 .....	51
10.9	Wiring Discrete Digital Outputs.....	52
10.10	Using the DAC Monitors.....	53
10.11	Wiring Encoder Output Signals.....	53
10.12	Motor Wiring.....	53
10.13	Regen Resistor Wiring .....	54
10.14	Step and Direction or Electronic Gearing Wiring .....	54
10.15	Encoder Motor Feedback .....	56
<b>11</b>	<b>System Startup .....</b>	<b>58</b>
11.1	Wiring Checks .....	58
11.2	Switch Settings .....	58
11.3	Apply control Power.....	58
11.4	Control Wiring Checks.....	59
11.5	Additional Safety Checks .....	59
11.6	Applying Bus Power .....	59
11.7	Motor Motion Checks.....	60
11.8	System Tuning.....	60
<b>12</b>	<b>Regulatory Information.....</b>	<b>61</b>
12.1	Conformance Requirements .....	61
12.2	UL and cUL Conformance .....	61
12.3	CE Approval.....	61
12.4	CE EMC Compliance .....	61
12.5	CE Test Setup.....	62
12.6	CE Test Setup.....	62
12.7	Declaration of Conformity .....	63
12.8	Installation and Commissioning .....	64
12.9	European Compliance .....	64
12.10	Low Voltage Directive and EN50178 .....	64
12.11	EMC Compliance with EN61800-3 .....	65
12.12	AC Mains Conducted Emissions.....	66
12.13	Regen Resistor.....	67
12.14	Additional EMC Information Sources.....	67

# 1 PRODUCT DOCUMENTATION

The S200 Position node system documentation contains information broken into several manuals and documents. Not all documents are required but no document stands alone. The documents are:

## Hardware Installation Manual

This document includes all aspects of product specifications and installation procedures. Wiring diagrams, mounting dimensions and recommendations, and physical properties can be found here. It is required to properly mount and wire the S200 Position Node product.

## User's Operation Manual

This document provides all information required to get an S200 Position Node product set up and configured for operation in the application. It includes functional descriptions, interface details, and troubleshooting information. Information regarding serial communications using Modbus is also provided in this document.

## S200 Position Node with CANopen Reference Manual

This document provides reference material and examples for communicating to the S200 Position Node over the CANopen field bus protocol.

## **S200 Position Node with DeviceNet Reference Manual**

This document provides reference material and examples for communicating to the S200 Position Node over the DeviceNet field bus protocol.

## Support materials

There may be a number of supporting documents located at our web site. Please check for the latest information.

## Locating Support Materials

All support materials are posted on the Danaher Motion website at [www.DanaherMotion.com](http://www.DanaherMotion.com). These files can be found under Drives \ AC Servo Drives \ S200.

## **Firmware and Software Updates**

A good general practice remains: If its not broken, don't fix it. There are times when firmware and software upgrade is required. These files can also be found at [www.DanaherMotion.com](http://www.DanaherMotion.com). Procedures can be found in the companion S200 Position Node User's Guide.

## **Abbreviations and Definitions**

Some common abbreviations used in this document are defined at the first use but the reader may note the following:

**S200 PN**: Short hand notation for the S200 Position Node product.

**'x'**: A lower case x may be used to signify a 'don't care' character in a string, number, or model number.

**GUI**: Graphical User Interface also called S200 OC Tools.

**Home**: A reference position to which other positioning motion is referenced.

**PE**: Protective Earth Ground

**REGEN**: Regenerated energy from a back-driven motor pumping energy back into the drive.

**REGEN Resistor**: An external power resistor attached to the drive that allows the drive to burn off excessive REGEN energy.

**Hall Channel**: A term used for a motor feedback signal that provides coarse absolute positioning information. Three channels provide 1-part-in-6 resolution per motor electrical cycle.

**Bus**: Short for Main Internal DC Bus Power Supply that is the DC voltage source for motor power.

**OIT**: Operator Interface Terminal; Same as HMI

**HMI**: Human Interface Terminal; Same as OIT

## 2 SAFETY

### 2.1 SAFETY SYMBOLS



**Warnings alert users to potential physical danger or harm. Failure to follow warning notices could result in personal injury or death.**



**Cautions direct attention to general precautions which, if not followed, could result in personal injury and/or equipment damage.**



**Notes highlight information critical to your understanding or use of the product.**

### 2.2 SAFETY NOTES

- As the user or person applying this unit, you are responsible for determining the suitability of this product for the application. In no event will Danaher Motion be responsible or liable for indirect or consequential damage resulting from the misuse of this product.



**READ these instructions before connecting power. Damage can result from MISWIRING at the power terminals.**

**DANGEROUS voltages are present on power input and motor output terminals.**

- Only qualified personnel are permitted to transport, assemble, commission, and maintain this equipment. Properly qualified personnel are persons who are familiar with the transport, assembly, installation, commissioning and operation of motors, and who have the appropriate qualifications for their jobs.
- Read all available documentation before assembling and using. Incorrect handling of products described in this manual can result in injury and damage to people and/or machinery. Strictly adhere to the technical information regarding installation requirements.
- Keep all covers and cabinet doors shut during operation.
- Be aware that during operation, the product has electrically charged components and hot surfaces.
- Control and power cables can carry a high voltage, even when the motor is not rotating.
- Never disconnect or connect the product while the power source is energized.
- After removing the power source from the equipment, wait at least 5 minutes before touching or disconnecting sections of the equipment that normally carry electrical charges (e.g., capacitors, contacts, screw connections). To be safe, measure the electrical contact points to each other and to electrical safety earth with a meter before touching the equipment.

### Motor Case Grounding

Ensure that the motor's case is connected to PE ground. The fourth wire in the motor cable connecting J2,1 to the motor case accomplishes this.



*If the motor is not properly grounded, dangerous voltages can be present on the motor case due to capacitive coupling between the motor windings and case.*

### Requirements for Safe Operation of the Drive

It is the machine builder's responsibility to insure that the complete machine complies with the Machine Directive (EN60204). The following requirements relate directly to the servo amplifier:

#### Emergency Stop



*If personal injury can result from motor motion, the user must provide an external hardwired emergency stop circuit outside the drive. This circuit must simultaneously remove power from the drive's motor power terminal J2-2, J2-3, and J2-4 and disable the drive (by open circuiting the connection to J4 pin 2).*



NOTE

*The motor will coast under this condition with no braking torque.*



CAUTION

*If braking torque is required to quickly stop the motor, a dynamic brake can be added that loads the motor's windings resistively. The motor should not be loaded until the servo drive is disabled. The holding brake, optional on Danaher Motion motors, is not intended to stop a spinning motor. It is designed to prevent a stopped motor from rotating due to an applied torque.*

#### Avoid Unexpected Motion



CAUTION

*Always remove power from J1 and wait 5 minutes before working on the machine or working anywhere where injury can occur due to machine motion.*

#### Avoid Electrical Shock



CAUTION

- *Never power the servo drive with the cover removed or with anything attached to circuitry inside the cover.*
- *If the drive must be removed from the cabinet, wait at least five minutes after turning off power before removing any cables from the drive or removing the drive from the mounting panel.*
- *Never connect or disconnect any wiring to the drive while power is applied. Always power down and wait five minutes before connecting or disconnecting any wires to the terminals.*

#### Avoid Burns



CAUTION

*The temperature of the drive's heat sink and housing as well as an external regen resistor may exceed 60° C. Therefore, there is a danger of severe burns if these regions are touched.*

#### Prevent Damage to the Drive

Follow these guidelines to prevent damage to the servo drive during operation:

- Never plug or unplug connectors with power applied.
- Never connect or disconnect any wires to terminals with power applied.
- If the drive indicates a fault condition, find the cause of the fault and fix it prior to resetting the fault or power-cycling the drive.

## 3 PRODUCT OVERVIEW

The S200 Position Node with CANopen/DeviceNet™ brings greater flexibility to the S200 drive platform by adding profile generation and field bus capabilities. It also brings added I/O, Digital Oscilloscope emulation, and the ability to use incremental encoder with commutation tracks (ComCoder) for motor feedback.

The S200 Position Node brushless position node servo drives with CANopen push high performance servo technology into lower power applications than was previously possible without having to compromise on reliability or package size. Couple a S200 position node drive with an AKM servo motor for a complete servo control solution designed to excel in applications such as semiconductor fabrication, electronic assembly, packaging, medical, and woodworking equipment.

The S200 position node servo drives with CANopen communication are the first all digital industrial drives with a velocity loop bandwidth up to 400 Hz offering unmatched system throughput and simplified tuning. High resolution (24 bit) feedback and high performance 3-5 kHz current loop bandwidth provide smooth motion and rapid start and stop action to optimize machine performance. Smart feedback and industry leading high bandwidth deliver fast and accurate commissioning by eliminating the need for servo loop tuning in most applications.

A separate "keep alive" power input allows rapid recovery from emergency stop conditions. Optically isolated inputs/outputs, positive locking connectors and full fault protection promise long machine life and immunity to accidental damage. A single motor power/feedback cable simplifies connectivity. All connectors and LED status indicators are easily accessible from the front of the drive.

### 3.1 HIGHLIGHTS

- DC or AC input voltage:  
DC type: 20 V ... 90 V  
AC type: 110 V ... 240 V, 1Ø or 3Ø, 50/60 Hz
- Highest performance all digital servo in the industry
- Operation and Setup via a PC using the S200 OC Tools setup software
- Easy set up and tuning with Smart Feedback Device
- Optimized performance with Danaher Motion AKM motors
- Rugged optically isolated I/O
- UL508C recognition, CE (EN50178, EN61800-3)
- Very compact footprint
- Full fault protection
- Velocity, Position, and Electronic Gearing, Step and Direction control
- Indexing - 180 unique motion tasks can be defined and initiated via the serial port, Can Port, or discrete inputs
- Jogs, Relative, Absolute, Simple Registration, and Home motion tasks can be easily setup and executed
- Individual motion tasks can be linked or blended with each other
- Digital Oscilloscope Functions
- Built-in CANopen / DeviceNet Communication bus
- Incremental Encoder Input port allows ComCoder motor feedback for position loop control.



## **3.2 INCREASED MACHINE THROUGHPUT & LONGER LIFE**

- Servo system performance is synonymous with machine throughput. The S200 POSITION NODE family takes servo performance to new heights.
- Industry-leading current loop bandwidth up to 5 kHz and velocity loop bandwidth up to 400 Hz means machine throughput can be increased by as much as 2 to 3 times.
- Robust design including full fault protection, locking connectors and optical isolation promise greater machine “up-time”.
- Smooth motion, a benefit of sinusoidal current control and high resolution (24 bit) feedback minimizes harsh torque disturbances that can cut short the life of mechanical components.
- Both the AC and the DC input drives are equipped with separate control power input to speed recovery from “E-Stop” conditions.
- CANopen Field Bus or DeviceNet communications

## **3.3 REDUCED ENGINEERING & SUPPORT TIME**

- Simplified tuning, friendly Graphical User Interface and shared components with Stepper products.
- Windows-based Graphical User Interface models the tree format found in Explorer so learning is quick and easy.
- Digital Oscilloscope emulator for easier setup.
- Easy to debug with full fault diagnostics reduce engineering support time.
- Field bus connectivity.

## **3.4 CE- / UL- CONFORMITY**

- The S200 position node with CANopen meets all relevant standards:
- EMC Directive 89/336/EWG, standard used ENG61800-3
- Low Voltage Directive 73/23/EWG, standard used 50178
- UL / cUL 508C recognized

## 3.5 MODEL NUMBER SCHEME

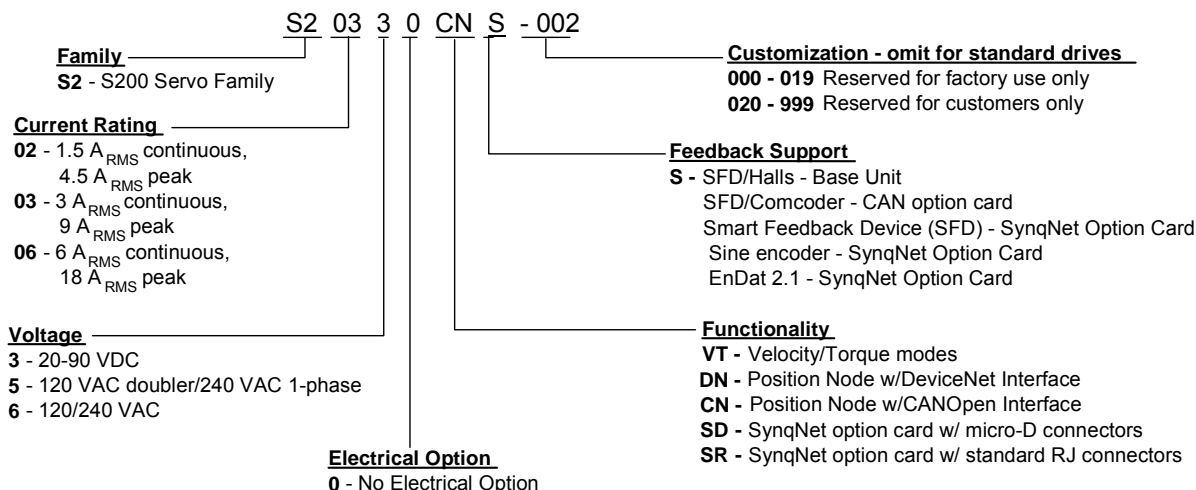

## 3.6 VALID DRIVE MODEL NUMBERS

### DC Input Power Drive Models

S20330-CNS: 90 V<sub>DC</sub>, 3/9 A<sub>RMS</sub> Base Unit, Profile Node with CanOpen

S20330-DNS: 90 V<sub>DC</sub>, 3/9 A<sub>RMS</sub> Base Unit, Profile Node with DeviceNet

S20630-CNS: 90 V<sub>DC</sub>, 6/18 A<sub>RMS</sub> Base Unit, Profile Node with CanOpen

S20630-DNS: 90 V<sub>DC</sub>, 6/18 A<sub>RMS</sub> Base Unit, Profile Node with DeviceNet

### AC Input Power Drive Models

S20250-CNS: 120VAC doubler/240VAC, 1 phase, 1.5/4.5 ARMS Base Unit, Profile Node with CanOpen

S20250-DNS: 120VAC doubler/240VAC, 1 phase, 1.5/4.5 ARMS Base Unit, Profile Node with DeviceNet

S20260-CNS: 120/240 VAC, 1/3-phase, 1.5/4.5 ARMS Base Unit, Profile Node with CanOpen

S20260-DNS: 120/240 VAC, 1/3-phase, 1.5/4.5 ARMS Base Unit, Profile Node with DeviceNet

S20350-CNS: 120VAC doubler/240VAC, 1 phase, 3/9 ARMS Base Unit, Profile Node with CanOpen

S20350-DNS: 120VAC doubler/240VAC, 1 phase, 3/9 ARMS Base Unit, Profile Node with DeviceNet

S20360-CNS: 120/240 VAC, 1/3-phase, 3/9 ARMS Base Unit, Profile Node with CanOpen

S20360-DNS: 120/240 VAC, 1/3-phase, 3/9 ARMS Base Unit, Profile Node with DeviceNet

S20650-CNS: 120VAC doubler/240VAC, 6/18 ARMS Base Unit, Profile Node with CanOpen

S20650-DNS: 120VAC doubler/240VAC, 6/18 ARMS Base Unit, Profile Node with DeviceNet

S20660-CNS: 120/240 VAC, 1/3-phase 6/18 ARMS Base Unit, Profile Node with CanOpen

S20660-DNS: 120/240 VAC, 1/3-phase 6/18 ARMS Base Unit, Profile Node with DeviceNet

S21260-CNS: 120/240 VAC, 1/3-phase 6/18 ARMS Base Unit, Profile Node with CanOpen

S21260-DNS: 120/240 VAC, 1/3-phase 6/18 ARMS Base Unit, Profile Node with DeviceNet

## 4 SPECIFICATIONS



NOTE

**Unless otherwise specified, the specifications are worst case limits and apply over the specified operating ambient temperature and over the specified operating line voltage.**

### 4.1 DRIVE FAMILY POWER

Drive Model Number	AC Input				DC Input	
	S20260	S20360	S20660	S212660	S20330	S20630
<b>Peak Output Current (<math>A_{RMS}</math>)<sup>1</sup></b>						
(0 to 40°C) Ambient ( $A_{RMS}$ )	4.5	9	18	30	9	18
<b>Minimum Peak Current Time</b>						
(Starting from 0 amps) seconds	3	3	3	3	3	3
<b>Continuous Output Current (<math>A_{RMS}</math>)<sup>2</sup></b>						
0 to 30°C ambient ( $A_{RMS}$ )	2.3	4.5	9	15	4.5	7.5
40° C ambient ( $A_{RMS}$ )	1.5	3	6	12	3	6
50° C ambient ( $A_{RMS}$ )	1	2	4	8	2	4
<b>Peak Output Power</b>						
240 VAC (VA), 3 phase	1500	3000	6000	10000	-	-
120 VAC (VA), 1 phase	750	1500	2400	-	-	-
75 VDC (VA)	-	-	-	-	750	1500
<b>Drive Continuous Output Power</b>						
240 VAC, 3 Phase (watts)	600	1100	2000	4000	-	-
240 VAC, 1 Phase (watts)	500	900	1500	2500	-	-
120 VAC, 1 Phase (watts)	250	450	-	-	-	-
75 VDC (watts)	-	-	-	-	250	500
<b>Continuous Motor Shaft Power at 3000 RPM (Nominal Bus – 10%)</b>						
0 to 30°C ambient (watts) 3-ph	300	750	1500	2500	-	-
0 to 30°C ambient (watts) 1-ph	300	750	1300	2200	180	315
40° C ambient (watts)	200	500	1000	2000	125	250
<b>RMS Line Current at Continuous Output Power</b>						
240 VAC 3 Phase ( $A_{RMS}$ )	2.7	5	9	16	-	-
240 VAC 1 Phase ( $A_{RMS}$ )	3.4	6.5	12 (Note 3)	18 (Note 3)	-	-
120 VAC 1 Phase ( $A_{RMS}$ )	3.4	6.5	12 (Note 3)	-	-	-
<b>+BUS Current – 75 VDC at Continuous Output Power<sup>3</sup></b>						
Average ( $A_{DC}$ )	-	-	-	-	3	6.7
Instantaneous Peak ( $A_{PEAK}$ )	-	-	-	-	12.7	25.5
Power Dissipation at 40°C $P_{CONT}$ (watts)	17	29	60	110	8	12

Drive Model Number:	AC Input				DC Input	
	S20260	S20360	S20660	S212660	S20330	S20630
<b>Shunt Regulator</b>						
Peak Power kW (500 ms)	4.4 at 36Ω	6.4 at 25Ω	10 at 15Ω	10 at 15Ω	-	-
Cont. Power watts	440 at 36Ω	640 at 25Ω	1000 at 15Ω	1500 at 15Ω	-	-
Maximum Regen Duty Cycle (%)	10 at 36Ω	10 at 25Ω	10 at 15Ω	15 at 15Ω	-	-
Regen Value (Ω)	25 – 50	25 – 50	12 – 50	8 – 50	-	-
<b>Bus Capacitance Energy Absorption (joules)</b>						
340 VDC Nominal BUS	15.5	15.5	20	45	-	-
75 VDC BUS with 4,000 μf (5 volt increase to 80 VDC)	-	-	-	-	1.5	1.5
<b>Output Current Ripple Freq fs (kHz)</b>	20	20	20	>16	31.2	31.2
<b>Minimum Motor Inductance I-I (mH)</b>	5	2.5	1.25	0.9	-	-
At 75 VDC	-	-	-	-	0.4	0.2
<b>Maximum Motor Inductance I-I (mH)</b>	300	150	75	45	30	15
<b>Maximum Motor Power Cable Length<sup>4</sup></b>						
18 AWG cable (m)	50	50	25	-	50	25
14 AWG Cable (m)	50	50	50	50	50	50

- 1 Peak Output Current listed is for sine mode. In six-step mode, the peak output currents are scaled to give the same output torque as in sine mode with a pure sinusoidal Back EMF motor.  
To convert  $A_{RMS}$  to  $A(0-pk)$ , multiply  $A_{RMS} * 1.414$ .
- 2 For Operation above 40° C ambient: Derate linearly to 67% at 50° C.  
At higher ambient temperatures (above 30° C) the S20360 drive needs to be mounted on a thermally conductive surface to limit the heatsink temperature to less than 75° C.
- 3 Single phase operation of the S20660 requires derating of continuous output power to avoid excessive AC line front-end currents.
- 4 See Appendix – Cables for voltage loss vs cable length.

## 4.2 INPUT POWER SPECIFICATIONS

AC Control Power Supply	
Input Voltage Range (RMS)	85 VAC to 265 VAC single phase 47 to 63 Hz 120 VDC to 375 VDC
Ride Through Time for AC Line Drop	85 VAC 60 Hz > 0.78 60 Hz cycles 120 VAC 60 Hz > 3.3 60 Hz cycles 240 VAC 60 Hz > 18.5 60 Hz cycles

AC Motor Power Supply	
Input Voltage Range (RMS) VAC	90 to 265
Phases	1 or 3
Transformer Suggested KVA	2 to 3
Maximum AC Line KVA <sup>1</sup>	100

<sup>1</sup>Maximum AC Line is specified to limit the mains surges to the drive.

AC Bus Voltage and Faults	
240 VAC Input Nominal Bus Voltage	320 VDC
120 VAC Input Nominal Bus Voltage	155 VDC
BUS Under voltage Fault	Factory Default is None
BUS Over voltage (BusOV) Fault	407 VDC $\pm$ 5%
BUS Regen Voltage	= 0.974*BusOV = 397 VDC Nominal

AC Inrush Current & Fusing	
Worse Case Inrush Peak Current at 240 VAC	140 A 0-p
Inrush pulse width	1.5 ms

Recommended Fusing Line Inputs				
Type – 250 VAC Time Delay Fuse				
	<b>S20260</b>	<b>S20360</b>	<b>S20660</b>	<b>S21260</b>
240 VAC 3 Phase (A <sub>RMS</sub> )	FRN-R-5	FRN-R-8	FRNR-15	FRN-R-25
240 VAC 1 Phase (A <sub>RMS</sub> )	FRN-R-5	FRN-R-10	FRN-R-20	FRN-R-30
120 VAC 1 Phase (A <sub>RMS</sub> )	FRN-R-5	FRN-R-10	FRN-R-20	-

AC Power on Delay	
Control Power Applied to Drive Operational	1.25 seconds

### 4.3 DC INPUT DRIVES - CONTROL AND POWER

DC Control Power	
Control Voltage Range (VDC) (J1-1 to J1-2)	+10 to +90
Control Input power (watts) <sup>1</sup>	2 to 8

<sup>1</sup>(20 watt min supply recommended) Refer to the DC Power Supply Section for detailed application information and requirements.

DC BUS Voltage and Faults	
+BUS Voltage Range (VDC) (J1-3 to J1-2)	+20 to +90
+BUS Under voltage Fault	+17 VDC nominal
+BUS Overvoltage Fault	+91 VDC nominal

DC Power On Delay	
Control Power Applied to Drive Operational	1.5 seconds

### 4.4 CONTROL LOOP PERFORMANCE

Motor Current Control	
Motor Phase Current Waveform	Pure sinusoidal or six-step, depending on feedback device
(In Sine or six-step mode output torque = Motor $K_T$ *Drive $I_{FB}$ )	

Motor Shaft Torque (Ignoring motor magnetic saturation)	
Peak	$K_T (N\text{-m}/A_{RMS}) * \text{Drive } I_{peak} (A_{RMS})$
Instantaneous	$K_T (N\text{-m}/A_{RMS}) * I_{FB} (A_{RMS})$

<b>Current Loop Bandwidth</b>	
<b>Maximum Bandwidth</b>	
AC Input Drive (kHz)	3
DC Input Drive (kHz)	5
<b>Recommended Bandwidth</b>	
AC Input Drive (kHz)	2
DC Input Drive (kHz)	3
SFD Auto Set (kHz) AC & DC	2
Bandwidth Variation For Fixed Motor L (% regulated independent of bus volt)	$\pm 2.5$
Update Period ( $\mu$ s)	0.8

<b>Recommended Max Motor Electrical Frequency (Hz)</b>	
AC Input Drive (Hz)	600
DC Input Drive (Hz)	900

<b>Velocity Loop Performance</b>	
Maximum Stable Bandwidth (Hz with SFD)	400
Update Period ( $\mu$ s)	0.8
Range (rpm)	0 to 18,300
Command Resolution	< 0.001 rpm analog 0.558 rpm serial

<b>Velocity Loop Compensation</b>	
KVP Range (Depends on I <sub>peak</sub> )	0.00044 to 0.106 (I <sub>peak</sub> )(1/rad/sec)
KVP Resolution (%)	10
KVI Range (Hz)	0 to > 22
KVI Resolution (%)	10
ARF0 <sup>1</sup> Range (Hz)	24.3 to > 46627
ARF1 <sup>1</sup> Range (Hz)	24.3 to > 46627

<sup>1</sup>Values for ARF0, ARF1; from 3012 to 24873 Hz cannot be set.

<b>Current Loop Specifications</b>	
- 3 dB Bandwidth (Hz)	> 2000
- 45° Phase Lag (Hz)	> 1000

<b>General Performance</b>	
Max Tracking Rate (rpm)	> 48600
Max Recommended Rate (rpm)	25000
Max Tracking Acceleration (rpm/sec)	> 16x10 <sup>6</sup>
Maximum Feedback Cable Length	50 m (164 ft)

## 4.5 MECHANICAL SPECIFICATIONS

Physical Dimensions and Specifications					
	S20330-CNS S20330-DNS S20630-CNS S20630-DNS	S20250-CNS S20250-DNS S20260-CNS S20260-DNS	S20350-CNS S20350-DNS S20360-CNS S20360-DNS	S20650-CNS S20650-DNS S20660-CNS S20660-DNS	S21260-CNS S21260-DNS
Drive Height (A)	152.4 mm 6.00 in	152.4 mm 6.00 in	175.0 mm 6.9 in	175.0 mm 6.90 in	177.0 mm 6.97 in
Drive Width (B)	28.7 mm 1.90 in	48.3 mm 1.90 in	54.8 mm 2.16 in	54.8 mm 2.16 in	76.2 mm 3.0 in
Drive Depth <sup>1</sup> (C)	100.8 mm 3.97 in	100.8 mm 3.97 in	131.6 mm 5.18 in	131.6 mm 5.18 in	152 mm 5.98 in
Mounting Hardware	M4 or #8	M4 or #8	M4 or #8	M4 or #8	M4 or #8
Drive Weight	0.40 kg	0.5 kg	0.77 kg	0.82 kg	1.5 kg
Nominal	1.00lb	1.10 lb	1.69 lb	1.80 lb	3.2 lb

<sup>1</sup> Depth measurement is for drive only. Add approximately 50.8 mm (2 in) to depth given in the table to accommodate mating connectors and wire bend radius.

## 4.6 I/O SPECIFICATIONS

Note: Analog command is not allowed in this product. Digital Velocity and Motion Task position loop control is the only possibilities.

Analog Output (DacMon)	
DACMON1, DACMON 2 (J4 14,15)	
Maximum Range (volts)	0.5 – 4.5
Full Scale Tolerance (%)	
Typical (Worse Case)	+/- 1 (± 5)
Linearity (% Full Scale)	<0.1
Monotonic to	< 2 <sup>-16</sup> Full Scale
Offset (mV)	< 100
Offset Drift (µV/°C typ.)	250

Quadrature Input	
Quadrature Input CHA (J12-12, 13) CHB (J12-14,15)	
Type	RS-422/RS-485, TTL, Open Collector compatible
Input Voltage	+/- 200mV Differential
Input Termination	Please see diagrams in manual
Maximum Line Frequency	625 kHz (corresponds to 2.5 MHz quadrature pulse rate)



<b>General Purpose Digital Inputs</b>	
DINP1-4, DINP6-9 (J4 2-5 and J12 2-5)	
Input Voltage	± ( 4.0 - 30.0) volts
Referenced to DINPCOM (J4-5)	
Input Current	0.65 - 6.7 mA
Response Time	1.0 ms
DINP5/DINP10 (J4-10 & 11, J12-8 & 9)	
Input Voltage	3.0 – 6.0 volts
Input Current	9.0 – 24.0 mA

<b>General Purpose Outputs</b>	
DOUT1, DOUT2, DOUT3 (J4-6,7,8,9 J12-6,7)	
Maximum Output Voltage	- 0.30 to 30.0 volts
Clamp Voltage	33 volt ± 6%
Maximum Output Current	50 mA
On voltage	1.0 volts at 10 mA
	1.2 volts at 50 mA
Response Time	1.0 ms

<b>Quadrature Outputs</b>	
Quadrature Output (CHA- J4-19, 20 CHB- J4-21,22 CHZ- J4-17,18)	
Type	RS-422/RS-485
Output Voltage	5.0 V Differential Output - Unloaded
Hysteresis	1/2 Quadrature Count corresponding to 1/8 Encoder Line Count
Resolution (With SFD)	125, 128, 500, 512, 1000, 1024, 2000, 2048, 2500, 4096, 5000, 8192, 10000, 16384, 20000, 32768
Maximum Output Frequency	2.5 MHz
Marker Pulse Width	Approximately 120 degrees

*Kollmorgen branded products do not support encoder output when using encoder feedback on motor. Products branded Danaher Motion do.*

## 4.7 ENVIRONMENTAL SPECIFICATIONS

<b>Environmental Specifications</b>	
Operating Temperature (° C) – Full Rating	0 to 40
Operating Temperature (° C) – Derated Linearly Derate Continuous Current to 67% of 40° C Rating	40 – 50
Pollution Degree	2
Storage Temperature (° C)	-20 to 70
Humidity (% non-condensing)	10 to 90
Altitude	<1500 m (5000 feet)

## 4.8 SMART FEEDBACK DEVICE (SFD)

<b>SFD (Smart Feedback Device)</b>	
Resolution/Rev (arc min)	24 bits = 0.0013
Repeatability (arc min RMS)	$< \pm 2^{-19}$ Rev = $\pm 0.04$
Noise	
No Filtering (arc min RMS)	$< 2^{-17}$ Rev RMS = 0.16
150 Hz Single Pole Filtered (arc min RMS)	$< 2^{-18}$ Rev RMS = 0.08
10 Hz Single Pole Filtered (arc min RMS)	$< 2^{-19}$ Rev RMS = 0.02
DC Offset Temperature Drift	$< 2^{-18}$ Rev/ $^{\circ}$ C = 0.08 arc min/ $^{\circ}$ C
Absolute Accuracy	
AKM1 (arc min)	$\pm 2^{-10.3}$ Rev = $\pm 17$
AKM2 or 3, 4 (arc min)	$\pm 2^{-11.1}$ Rev = $\pm 10$
Communications Update Period ( $\mu$ s)	51.2

## 5 ACCESSORIES

### 5.1 CABLES

Danaher Motion offers pre-made high quality cables for help in installation.

#### 5.1.1 Motor and feedback cables

Motor and Feedback cable selections are covered in our Motioneering package to help select the correct sets based on motor and drive size selection.

#### 5.1.2 Serial Communications Cable

Danaher Motion offers a 6 ft serial communications cable designed to connect directly between the S200 Position Node and standard PC 9 Pin communications port. Order Part Number P7S2-232-D.



## 5.2 CONNECTOR KITS

Danaher Motion offers several connector kit options to help interface drive connections. Please note that there are connector kits that are designed to interface to just the base unit drive and connector kits designed for the auxiliary S200 Position Node auxiliary features. More than one connector kit may be required.

### 5.2.1 Base Unit Connector Kits

CK-S200-MF connector kit includes motor and feedback connectors for all low power base unit models. (JJ2 and J4).

This connector kit is useful in applications and customers not using Danaher Motion Cables Sets.

Applicable Drive Models:  
S202x0-xNS, S20350-xNS, S20360-xNS,  
S20660-xNS.



CK-S200-MP-AC connector kit includes motor and power connectors for all low power AC Input base unit models. (J1 and J2).

This connector kit is useful in applications and customers not using Danaher Motion Armature cables.

Applicable Drive Models:  
S20250-xNS, S20260-xNS, S20350-xNS,  
S20360-xNS, S20660-xNS.

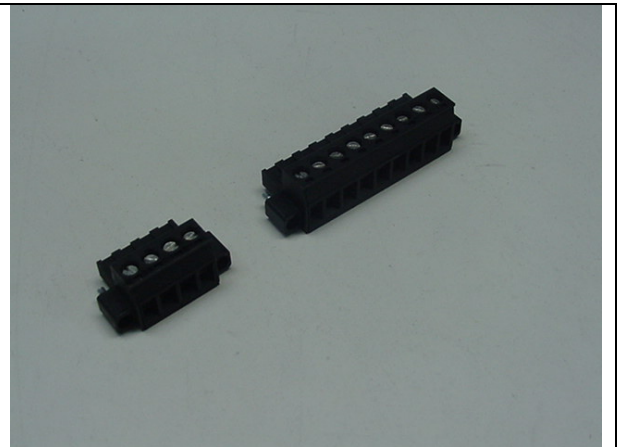

CK-S200-IP-DC connector kit includes power and signal connectors for the S200 Base Unit models. (J1 and J4).

This connector kit provides the auxiliary connectors required when purchasing Danaher Motion Cable sets.

Applicable Drive Models:  
S20330-xNS, S20630-xNS



CK-S200-IP-DC-TB connector kit includes the power connector and signal connector with terminal block break out for the DC S200 Base Unit models. (J1 and J4).

This connector kit provides the auxiliary connectors required when purchasing Danaher Motion Cable sets when screw terminals are preferred over soldering of J4.

Applicable Drive Models:  
S20330-xNS, S20630-xNS

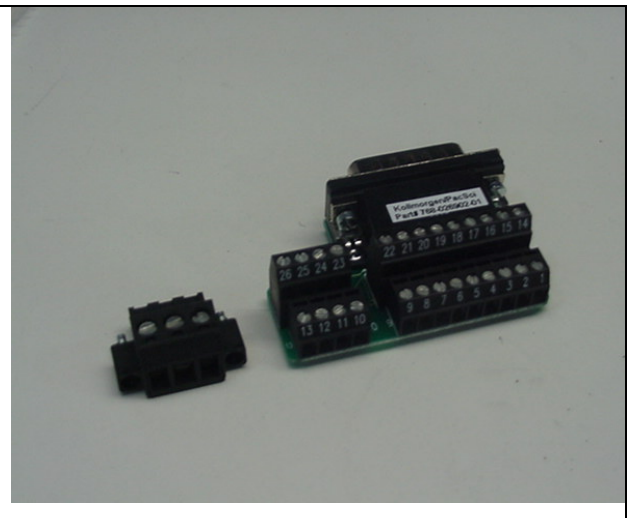

CK-S200-IN-AC connector kit includes both the command signal connector, J4, and the AC power connector, J1, for the low power S200 Base Unit models. Solder cup connector.

This connector kit provides the auxiliary connectors required when purchasing Danaher Motion Cable sets.

Applicable Drive Models:  
S20250-xNS, S20260-xNS, S20350-xNS, S20360-xNS, x20660-xNS.



CK-S200-IN-AC-TB connector kit includes both the command signal connector, J4, and the AC power connector, J1, for the low power S200 Base Unit models. Cage Clamp connector kit.

This connector kit provides the auxiliary connectors required when purchasing Danaher Motion Cable sets where terminal screws are preferred over soldering of J4.

Applicable Drive Models:  
S20250-xNS, S20260-xNS, S20350-xNS, S20360-xNS, x20660-xNS.

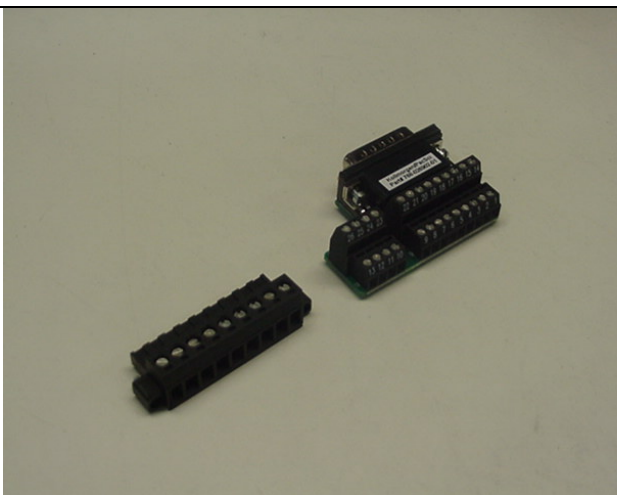

CK-S200-IN-AC connector kit includes command signal connector, J4, for the S200 Base Unit models. Solder cup connector.

Applicable Drive Models:  
All models



CK-S200-IN-AC-TB connector kit includes command signal connector, J4, for the S200 Base Unit models. Cage clamp screw terminal connector.

Applicable Drive Models:  
All models

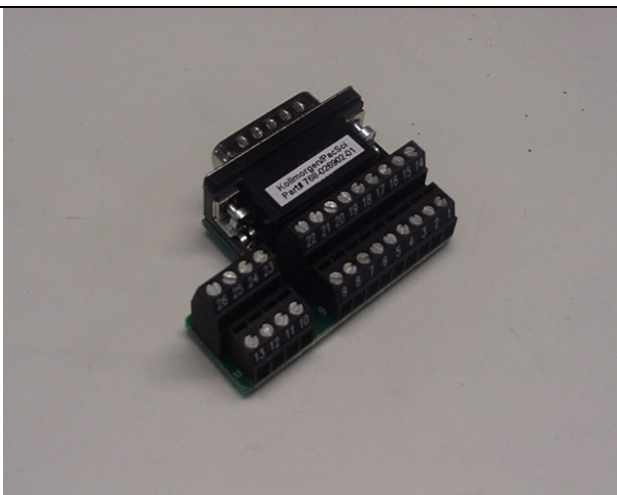



## 5.2.2 Position Node Connector Kits

CK-S200-CNDN connector kit includes command signal connector, J12, and the encoder connector, J13 for the S200 Position Node auxiliary functions. Solder cup connectors.

Applicable Drive Models:  
All models with DNS or CNS suffix.



CK-S200-CNDN-TB connector kit includes command signal connector, J12, and the encoder connector, J13 for the S200 Position Node auxiliary functions. For applications desiring screw terminal (cage clamp) over soldered connections

Applicable Drive Models:  
All models with DNS or CNS suffix.

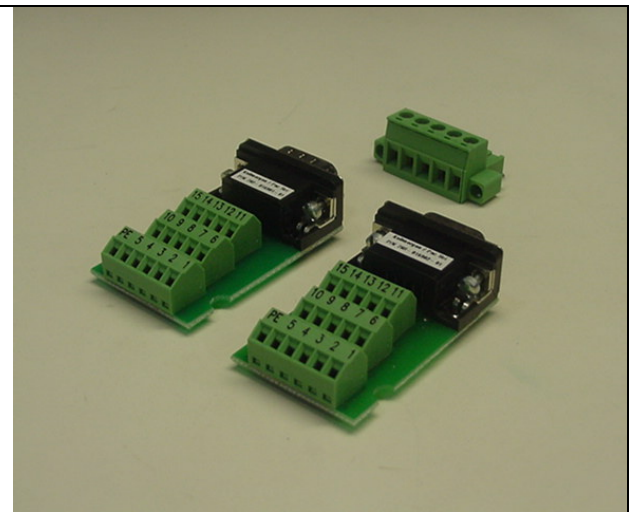

## 5.3 *REGEN RESISTOR*

Danaher Motion offers the ERH-26 fully enclosed, thermally protected regen resistor rated at 26 ohms, 150 watts. The resistor has connection leads and an integrated thermal switch with fast-on type connectors. The thermal switch can be wired into the user's safety circuit. The ERH-26 is a UL Recognized component.



## **5.4 *DIN RAIL TERMINAL BREAK OUTS***

Soon to be offered. Ask service representative for latest availability.

## **5.5 *OPERATOR INTERFACE TERMINALS***

Danaher Motion does not currently offer direct purchase of Operator Interface Terminals other than with complete systems. There are many units available in the general industrial equipment market place. Virtually any terminal that has the ability to be configured for your application and has support for MODbus RTU with the ability to read and write registers formatted for double registers (32 bit) in both long integer and floating point formats should be compatible with the S200 Position Node product.

## **5.6 *SYSTEMS CAPABILITIES***

Danaher Motion offers a variety of pre-configured systems from component kits to pre-wired systems in NEMA 12 enclosures. Please consult your local Danaher Motion representative for details.



## 6 INSTALLATION

### 6.1 UNPACKING AND INSPECTING

Open the box and remove all the contents. Check to ensure there is no visible damage to any of the equipment.



***Use proper procedures when handling electronic components to avoid damage to equipment.***



***Remove all packing material and equipment from the shipping container. Be aware that some connector kits and other equipment pieces may be quite small and can be accidentally discarded. Do not dispose of shipping materials until the packing list has been checked.***



***Upon receipt of the equipment, inspect components to ensure that no damage has occurred in shipment. If damage is detected, notify the carrier immediately. Check all shipping material for connector kits, documentation, diskettes, CD-ROM, or other small pieces of equipment.***

### 6.2 MOUNTING

The S200 drives are designed for operation in a cabinet using the following installation instructions:

- Mount the drives vertically inside a cabinet on a flat, solid, electrically conductive, mounting surface connected to PE (protective earth ground) and capable of supporting the weight of the unit.
- Provide a good connection to PE. Remove the paint on the mounting surface over an area extending at least 12 mm (0.5 in) from the mounting bolts to achieve good electrical connection over a large area between the drive and grounded mounting surface.
- Ensure the environment within the cabinet meets the requirements listed in the environmental specifications table.

## 6.3 DIMENSIONS

<b>Mounting Dimensions</b>				
	<b>S20330-CNS</b>	<b>S202x0-CNS</b>		
	<b>S20330-DNS</b>	<b>S202x0-DNS</b>		
	<b>S20630-CNS</b>	<b>S203x0-CNS</b>	<b>S206x0-CNS</b>	<b>S21260-CNS</b>
	<b>S20630-DNS</b>	<b>S203x0-DNS</b>	<b>S206x0-DNS</b>	<b>S21260-CNS</b>
<b>Drive Dimensions</b>				
Drive Height (A)	152.4 mm 6.00 in	175.0 mm 6.90 in	175.0 mm 6.90 in	177.0 mm 6.97 in
Drive Width (B)	48.3 mm 1.90 in	54.8 mm 2.16 in	64.0 mm 2.52 in	76.2 mm 3.0 in
Drive Depth <sup>1</sup> (C)	100.8 mm 3.97 in	131.6 mm 5.18 in	131.6 mm 5.18 in	152 mm 5.98 in
<b>Clearance Requirements</b>				
Top and Bottom (D)	12.7 mm 0.50 in	25.4 mm 1.0 in	25.4 mm 1.0 in	25.4 mm 1.0 in
Side to Side (E)	12.7 mm 0.50 in	25.4 mm 1.0 in	25.4 mm 1.0 in	25.4 mm 1.0 in
<b>Mounting Dimensions</b>				
Horizontal Mounting Offset (F)	24.6 mm 0.97 in	25.6 mm 1.01 in	25.6 mm 1.01 in	31.7 mm 1.25 in
Vertical Mounting Offset (G)	4.1 mm 0.16 in	4.3 mm 0.17 in	4.3 mm 0.17 in	4.8 mm 0.19 in
Vertical Mounting Height (H)	144.3 mm 5.68 in	169.5 mm 6.67 in	169.5 mm 6.67 in	169.5 mm 6.67 in
Drive to Drive Mounting (J)	60.96 mm 2.40 in	80.3 mm 3.16 in	89.4 mm 3.52 in	101.6 mm 4.0 in
<b>Mounting Hardware</b>	M4 or #8	M4 or #8	M4 or #8	M4 or #8
<b>Drive Weight</b>	0.5 kg 1.10 lb	0.85 kg 1.86 lb	0.5 kg 1.10 lb	1.5 kg 3.2 lb

<sup>1</sup> *Depth measurement is for drive only. Add approximately 50.8 mm (2 in) to depth given in the table to accommodate mating connectors and wire bend radius.*

## 6.4 MOUNTING OUTLINE

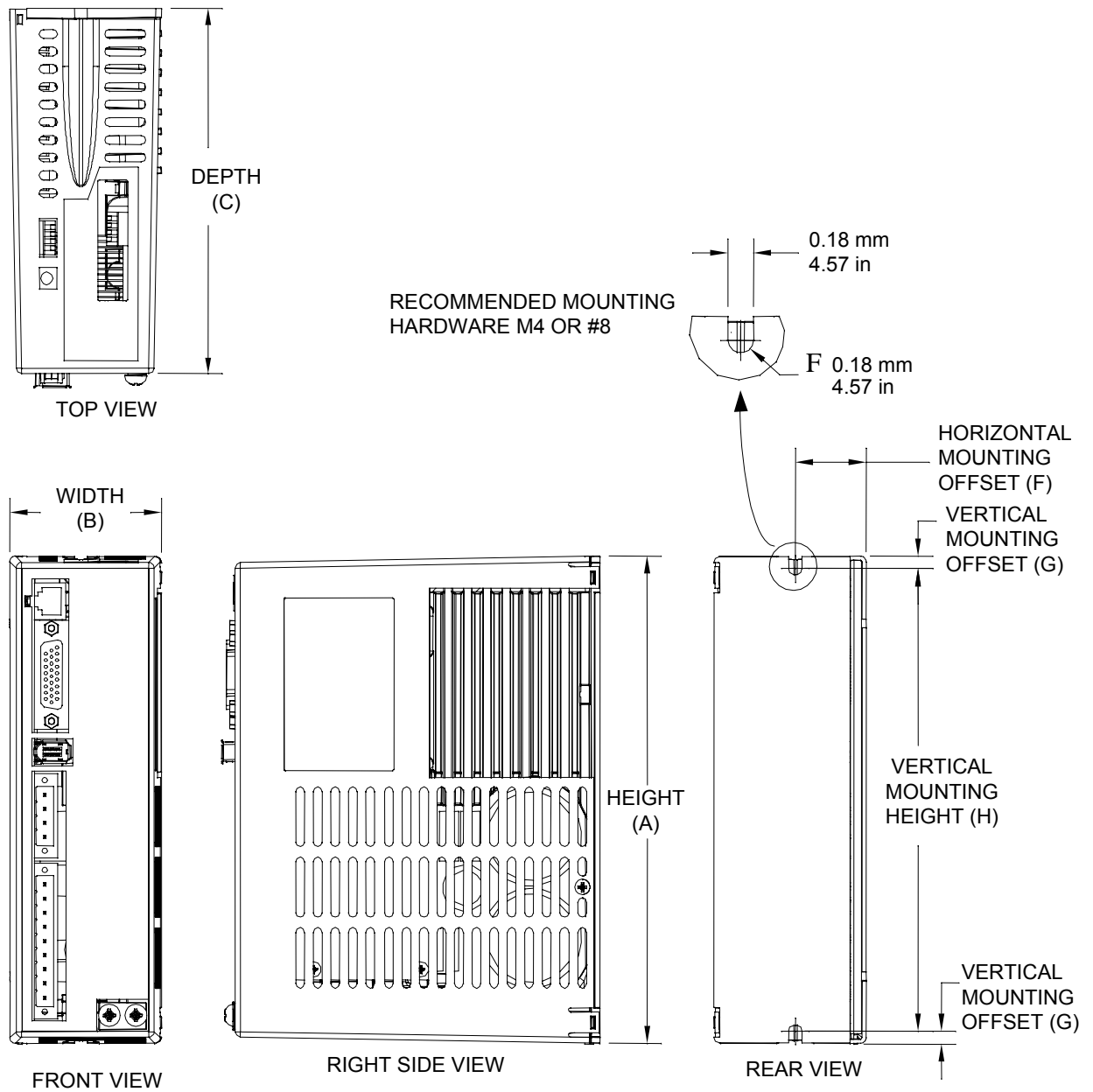

# 7 WIRING DIAGRAMS

The following diagrams present the electrical connection diagrams for High Power AC units, Low Power AC units, and DC Power units.

## 7.1 LOW POWER AC DRIVE WIRING DIAGRAM

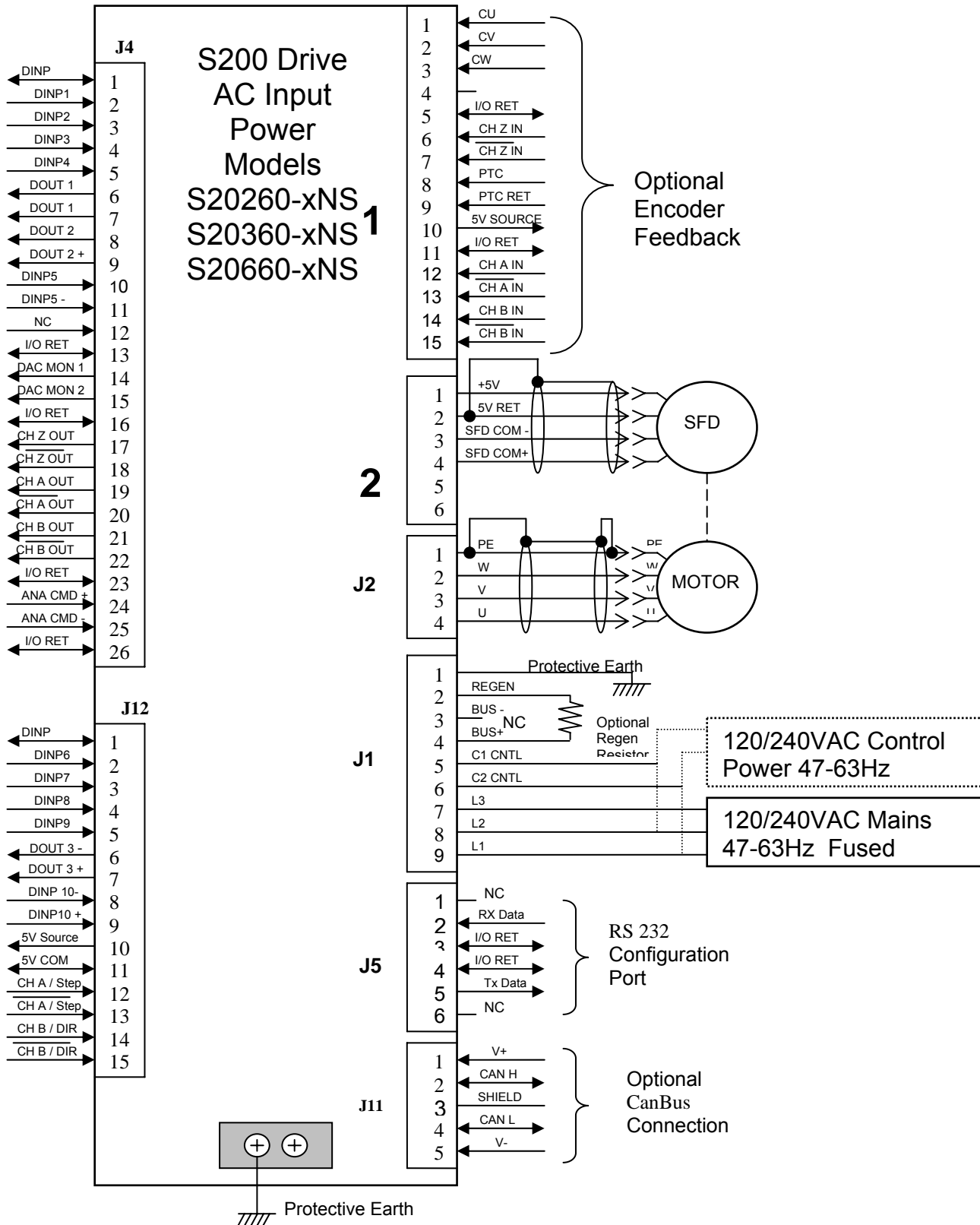

## 7.2 HIGH POWER AC WIRING DIAGRAM

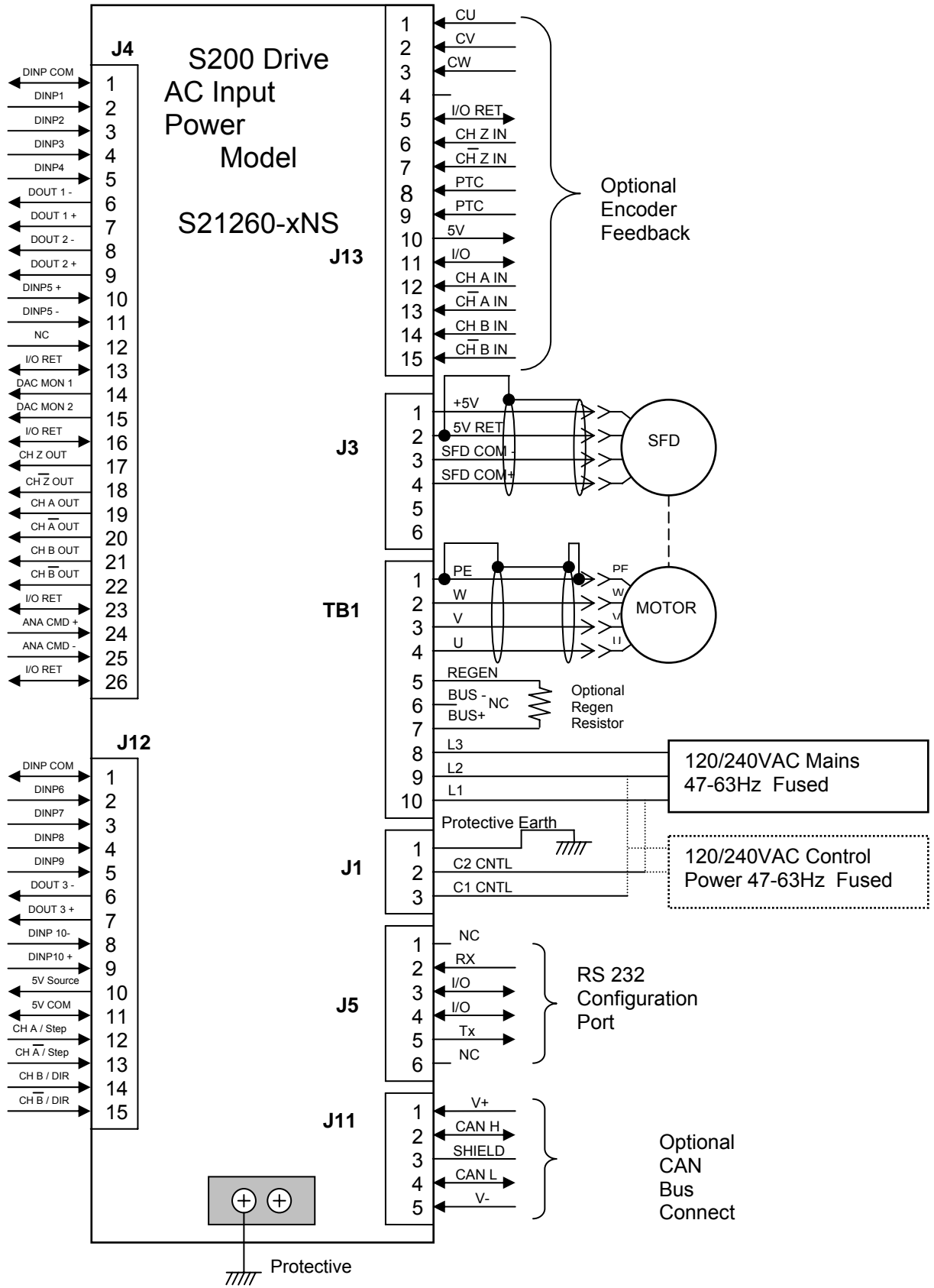

### 7.3 DC MODELS DRIVE WIRING DIAGRAM

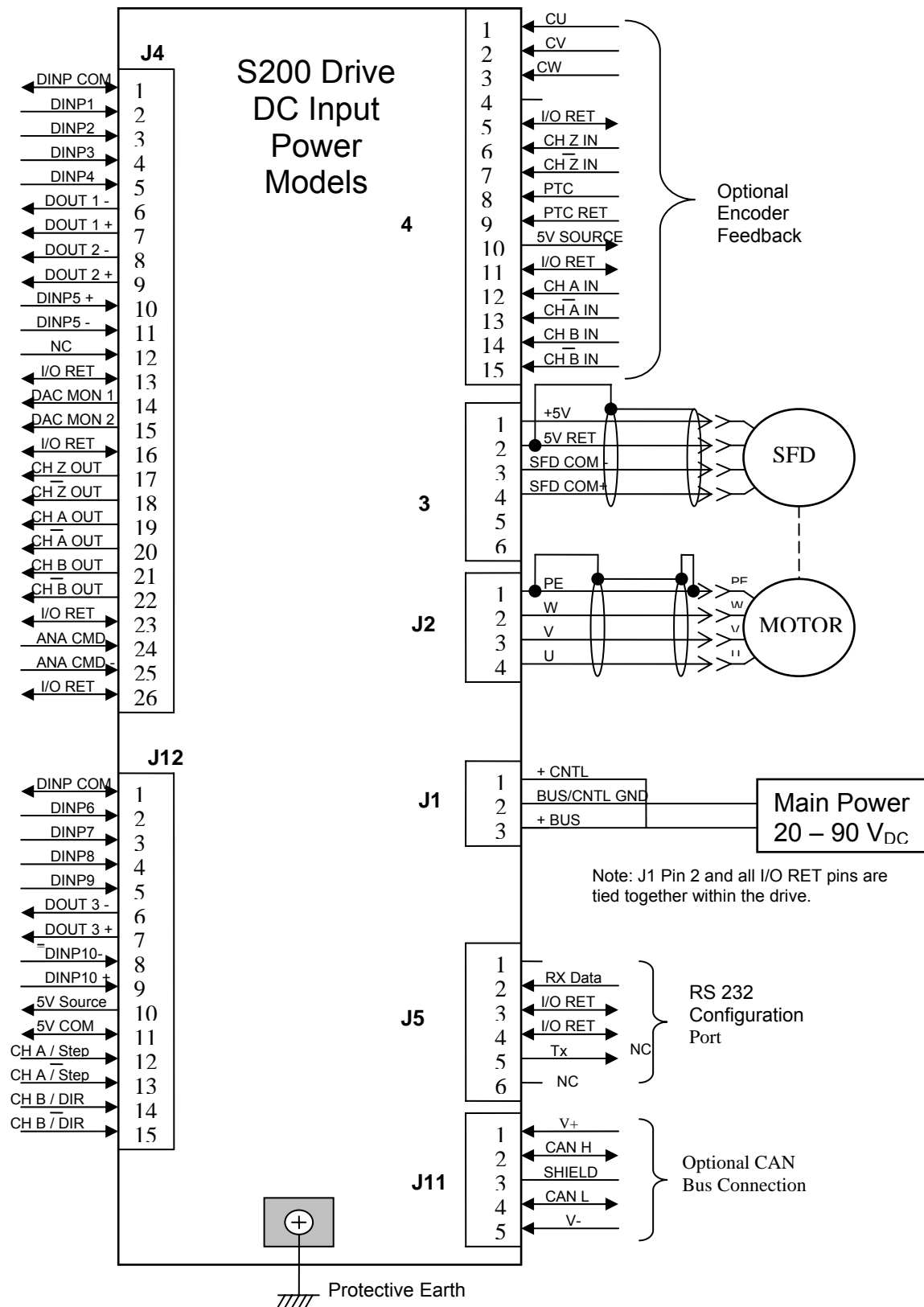

## 8 CONNECTOR PINOUT AND DESCRIPTIONS

The following section describes the user connections to the S200 Position Node by connector. The front part of this section presents AC / DC input Power and Power Terminal wirings for various drive models. J1 and TB1 vary according to the model. Please refer to the proper description for your model.

### 8.1 PE ALL DRIVE MODELS

Each S200 Position Node product has at least one screw terminal from its frame exposed to the front of the product for customer wiring to Protective Earth (PE) ground. This connection should be made with heavy gage, high strand count wire and a ring lug terminal directly back to the incoming earth ground distribution block. Power should not be applied if this connection does not exist.

PE Ground Terminals  
(Typical)



## 8.2 J1 – LOW POWER AC INPUT POWER MODELS DRIVE POWER

Models S202x60-xNS, S203x0-xNS, S206x0-xNS

The S200 AC input drives are capable of direct line operation. All units are fully isolated and do not require external isolation transformers. The inrush current on the connection to the line is internally limited to a safe level for the drive. There are no voltage selection or ranging switches required to operate within the specified voltage input ranges. Please note warnings that follow.

The S200 series drives are functionally compatible with all standard forms of three phase AC lines:

- Grounded neutral WYE
- Open-Delta Grounded Leg
- TEE

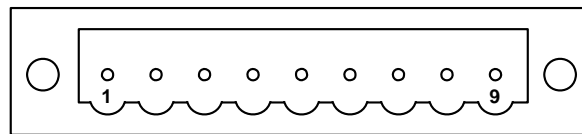

**Figure 7.1: J1 Connector view from front of drive**

Pin	Description
J1-1	PE (Protective Earth) – Must be tied back to central earth bar.
J1-2	REGEN – Connection for optional external regen resistor.
J1-3	-BUS DC – Internal DC Bus negative connection (Not normally used)
J1-4	+BUS – Internal DC Bus Positive Connection (Regen Resistor Termination Point)
J1-5	C2 CTRL VAC – Logic control Power can be tied to 120 or 230Vac input
J1-6	C1 CTRL VAC – Logic Control Power can be tied to 120 or 230Vac input
J1-7	L3 240 VAC – Main Line for Bus power: Used for 3 <sup>rd</sup> Phase
J1-8	L2 240/120 VAC – Main Line for Bus Power. Used for 1 or 3 Phase
J1-9	L1 240/120 VAC – Main Line. Used for 1 or 3 Phase

Please refer to the Specifications Section for appropriate rating and fusing requirements.



**NOTE**

***It is the customer's responsibility to supply appropriate fuses or circuit breakers in the J1 AC drive power lines to comply with local electrical codes.***



**NOTE**

For maximum line droop tolerance connect logic power to 230Vac instead of 115Vac

**WARNING**

After powering down the drive, monitor the BUS voltage by connecting a meter from J1-4 (+BUS) to J1-3 (-BUS) to verify the internal BUS capacitors have discharged prior to working on the drive.

**WARNING**

The Regen input is not short circuit protected. The Regen Resistance **MUST** be within specified ranges to prevent damage to the drive. For example, between 25 to 50  $\Omega$  for the S20260, S20360 drives or 15 to 50  $\Omega$  for the S20660.

**CAUTION**

To avoid damage to the connector and drive, **NEVER** plug or unplug J1 with power applied.

**WARNING**

For single-phase systems Main Bus power must be wired to L1 and L2. Do not connect L3.

**WARNING**

Selected Regen Resistor must be able to handle constant 390Vdc connection without risk of fire or must otherwise be thermally protected with an overload device.

### J1 Mating Connector Information

Screw Terminal Connector:

12 – 24 AWG Wire Range, Phoenix MSTB2,5/9-STF-5,08-BK

OR Spring Cage Clamp Connector

12 – 24 AWG Wire Range, Phoenix FKC 2,5/9-SFT-5,08-BK

OR Crimp Connector

14-20 AWG Wire Range, Phoenix MSTBC 2,5/9-STZF-5,08-BK

Crimp Contact: 14-16 AWG Wire Range, Phoenix MSTBC-MT 1,5-2,5

Crimp Contact: 18-20 AWG Wire Range, Phoenix MSTBC-MT 0,5-1,0

Refer to [www.phoenixcon.com](http://www.phoenixcon.com).

## 8.3 J1 – AC INPUT CONTROL POWER HIGH POWER AC MODELS

Models: S21260-xNS

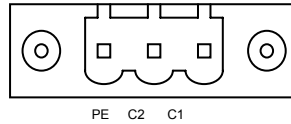

Pin	Description
J1-1	E (Protective Earth) – Must be tied back to central earth bar.
J1-2	2 CTRL VAC – Logic control Power. Use 120 or 240Vac.
J1-3	1 CTRL VAC – Logic Control Power. Use 120 or 240 Vac.

Please refer to the Specifications section for fusing and rating information.



NOTE

***It is the customer's responsibility to supply appropriate fuses or circuit breakers in the J1 AC drive power lines to comply with local electrical codes.***



NOTE

***For maximum line droop tolerance connect logic power to 230Vac instead of 115Vac***



CAUTION

***To avoid damage to the connector and drive, NEVER plug or unplug J1 with power applied.***

### Mating Connector Information:

Screw Terminal Connector

12 – 24 AWG Wire Range, Phoenix MSTB2,5/3-STF-5,08-BK

OR Spring Cage Clamp Connector

12 – 24 AWG Wire Range, Phoenix FKC 2,5/3-SFT-5,08-BK

OR Crimp Connector

Crimp Shell: 14-20 AWG Wire Range, Phoenix MSTBC 2,5/3-STZF-5,08-BK

Crimp Contact: 14-16 AWG Wire Range, Phoenix MSTBC-MT 1,5-2,5

Crimp Contact: 18-20 AWG Wire Range, Phoenix MSTBC-MT 0,5-1,0

Refer to [www.phoenixcon.com](http://www.phoenixcon.com).

## 8.4 TB1: HIGH POWER AC POWER CONNECTIONS

Models: S21260-xNS

The S200 AC input drives are capable of direct line operation. All units are fully isolated and do not require external isolation transformers. The inrush current on the connection to the line is internally limited to a safe level for the drive. There are no voltage selection or ranging switches required to operate within the specified voltage input ranges.

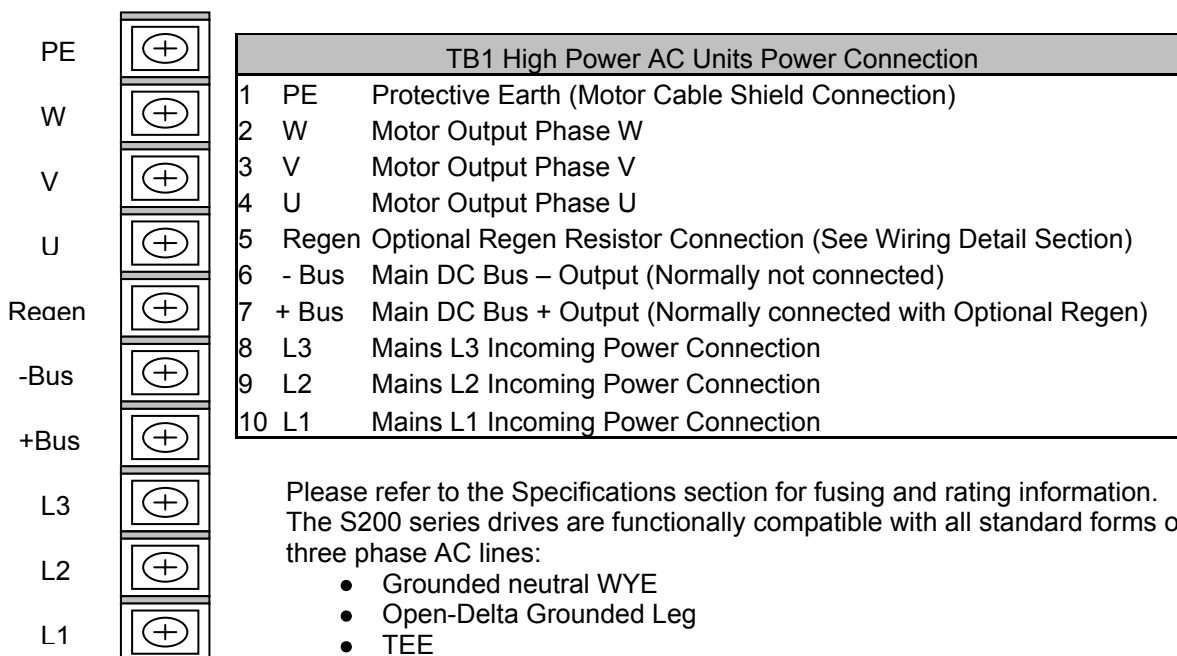

**NOTE**

***It is the customer's responsibility to supply appropriate fuses or circuit breakers in the TB1 AC drive power lines to comply with local electrical codes.***



**NOTE**

**For maximum line droop tolerance connect logic power to 230Vac instead of 115Vac**



**WARNING**

**After powering down the drive, monitor the BUS voltage by connecting a meter from TB1-7 (+BUS) to TB1-6 (-BUS) to verify the internal BUS capacitors have discharged prior to working on the drive.**



**WARNING**

**The Regen input is not short circuit protected. The Regen Resistance **MUST** be within specified ranges to prevent damage to the drive. 15 Ohms minimum resistance for the S21260-xNS.**



**WARNING**

**Selected Regen Resistor must be able to handle constant 390Vdc connection without risk of fire or must otherwise be thermally protected with an overload device.**



**WARNING**

***Do not apply power or operate unit without the terminal block cover in place.***

### Recommended Mating Connectors:

- Spring Fork Lugs or M4 or #8 screws
- Hollingsworth SS20948SF
- Molex 19099-032
- Or Equivalent

## 8.5 J1 – DC INPUT POWER MODELS DRIVE POWER CONNECTOR

The S200 DC input drives should be powered from power supplies with reinforced isolation. On DC input drives, J1 is a 3 pin plugable connector.

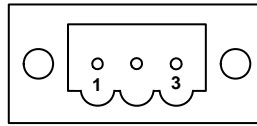

(J1 Connector view from front of drive).

J1: DC Units Control Power	
Pin	Description
J1-1	+ CNTL ( Logic Input Power 10-90Vdc less than 8 watts)
J1-2	BUS / CNTL GND (Logic and Bus Return)
J1-3	+ DC BUS Input Power (20 to 90Vdcc)

Please refer to the Specifications section for fusing and rating information.



CAUTION

**To avoid damage to the connector and drive, NEVER plug or unplug J1 with power applied.**



NOTE

**Refer to the DC Power Supply Requirements section for detailed requirements selecting a compatible power supply.**

### Mating Connector Information

- Screw Terminal Connector
- 12 – 24 AWG Wire Range, Phoenix MSTB2,5/3-STF-5,08-BK  
OR Spring Cage Clamp Connector
- 12 – 24 AWG Wire Range, Phoenix FKC 2,5/3-SFT-5,08-BK  
OR Crimp Connector
- Crimp Shell: 14-20 AWG Wire Range, Phoenix MSTBC 2,5/3-STZF-5,08-BK
- Crimp Contact: 14-16 AWG Wire Range, Phoenix MSTBC-MT 1,5-2,5
- Crimp Contact: 18-20 AWG Wire Range, Phoenix MSTBC-MT 0,5-1,0

Refer to [www.phoenixcon.com](http://www.phoenixcon.com).

## 8.6 J2 – MOTOR POWER CONNECTOR

Applicable Models: All except S21260-xNS (See TB1, above for this model).

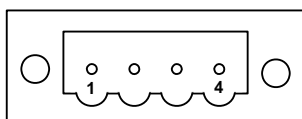

(J2 Connector view from front of drive).

Pin	Description
J2-1	PE (Chassis Ground) on S200 AC Input Drives BUS/CTRL GND on S200 DC Input Drives Intended for motor ground and motor cable shield connection.
J2-2	Motor Phase W Output
J2-3	Motor Phase V Output
J2-4	Motor Phase U Output

Please refer to the product specifications section for appropriate wire sizing information.

### Mating Connector Information

Screw Terminal Connector: 12 – 24 AWG Wire Range, Phoenix MSTB2,5/4-STF-5,08-BK  
OR

Spring Cage Clamp Connector: 12 – 24 AWG Wire Range, Phoenix FKC 2,5/4-SFT-5,08-BK  
OR

Crimp Connector

Crimp Shell: 14-20 AWG Wire Range, Phoenix MSTBC 2,5/4-STZF-5,08-BK

Crimp Contact: 14-16 AWG Wire Range, Phoenix MSTBC-MT 1,5-2,5

Crimp Contact: 18-20 AWG Wire Range, Phoenix MSTBC-MT 0,5-1,0

Refer to [www.phoenixcon.com](http://www.phoenixcon.com)

## 8.7 J3 – SFD FEEDBACK CONNECTOR

J3 is a 6-pin plugable IEEE 1394 style connector for the feedback device. Although this connector mechanically accepts standard IEEE 1394 cables, it is electrically **not** an IEEE 1394 interface. The base drive accepts either SFD (Smart Feedback Device) or Hall inputs.

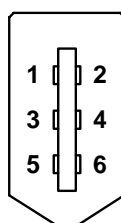

Pins	Description
J3-1	+5 V Supply (200 mA) from drive
J3-2	+5 RTN 5V common
J3-3	SFD Communications -
J3-4	SFD Communications +
J3-5	NC
J3-6	NC
Shell	Shield Connection

(J3 Connector view from front of drive)

### Mating Connector Information

IEEE1394, Firewire type, 2.0 mm plug set

22 AWG Max., Molex 55100-0600

Refer to [www.molex.com](http://www.molex.com) for assembly instructions.

## 8.8 J4 – COMMAND I/O CONNECTOR

J4 is a 26-Position High Density D subminiature female connector.

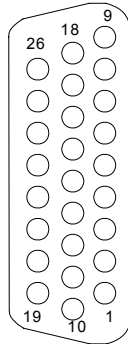

(J4 Connector view from front of drive.)

Pin	Description	Pin	Description
J4-1	DINP COM	J4-14	DAC MON1
J4-2	DINP1 (Enable)	J4-15	DAC MON2
J4-3	DINP2	J4-16	I/O RTN
J4-4	DINP3	J4-17	Encoder Output Channel Z
J4-5	DINP4	J4-18	Encoder Output Channel $\bar{Z}$
J4-6	DOUT1-	J4-19	Channel A Encoder Output
J4-7	DOUT1+ (Fault)	J4-20	Channel $\bar{A}$ Encoder Output
J4-8	DOUT2- $\text{---}$	J4-21	Channel B Encoder Output
J4-9	DOUT2+ (RUN)	J4-22	Channel $\bar{B}$ Encoder Output
J4-10	DINP 5+	J4-23	I/O RTN
J4-11	DIP5 $\text{---}$	J4-24	Analog Command Input +
J4-12	Reserved	J4-25	Analog Command Input -
J4-13	I/O RTN	J4-26	I/O RTN

See Specifications Section for ratings and Wiring Information for wiring details.

### Mating Connector Information

26-Pin Male High Density D-Sub with Back shell Kit  
 24 AWG Max., NorComp 180-026-102-001 – D-Sub Connector  
 NorComp 978-015-010-03-1 – Back shell Kit

**Refer to [www.norcomp.net](http://www.norcomp.net).**

## 8.9 J5: SERIAL PORT CONNECTIONS

The S200 Position Node serial port is wired to connector J5 using RS232 physical layer protocol.

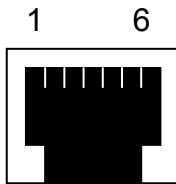

J5 RS232 Serial Port Connections		
Pin		Function
1	NC	
2	Drive Receive RS232 Data	
3	DC Common	
4	DC Common	
5	Drive Transmit RS232 Data	
6	NC	

### Mating Connector Information

Standard RJ11 cord

Or Plug Example AMP 5-555426-3

## 8.10 J11 CAN BUS CONNECTIONS

J11 is a five-pin plugable connector to the CAN physical layer and is compliant with CANOpen and the DeviceNet specification (less color code requirements).

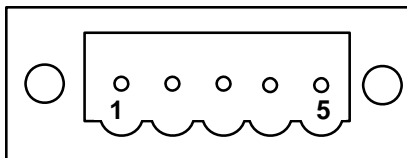

Pin	Description	DeviceNet Color
J11-1	V-: Power of CAN Bus	Black
J11-2	CAN_L: Comm Low	Blue
J11-3	Shield	Bare
J11-4	CAN_H: Comm High	White
J11-5	V+: Power of CAN bus	Red

### Mating Connector

PHOENIX MSTB 2,5/ 5-STF-5,08 AU

Or Equivalent

## 8.11 J12 CONNECTOR

J12, Option Card General Purpose I/O is a 15-Position High Density D subminiature male (plug) connector. 5 User-configurable discrete inputs, one user-configurable output, and encoder (or step and direction ) input channels are provided on this 15 Pin High Density D socket connector. Detailed electrical information is given elsewhere in this document.

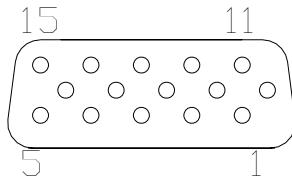

J12 Connector Pin Out		
Pin	Name	Description
J12-1	DINP COM	Common rail for DINP6-9
J12-2	DINP6	Digital Input 6 +/- 4 to 30V DC Operation
J12-3	DINP7	Digital Input 7 +/- 4 to 30V DC Operation
J12-4	DINP8	Digital Input 8 +/- 4 to 30V DC Operation
J12-5	DINP9	Digital Input 9 +/- 4 to 30V DC Operation
J12-6	DOUT3 -	DOUT 3 Opto Isolator Emitter
J12-7	DOUT3 +	DOUT3 Opto Isolator Collector
J12-8	DINP10 -	Digital Input 10 Cathode 5V nominal operation
J12-9	DINP10 +	Digital Input 10 Anode: 5V Nominal operation
J12-10	+5VDC	5V Source from drive. Not to exceed 150mA
J12-11	I/O RTN	5V Common, Common for CMD Channels
J12-12	CMD CH A+	Gearing Input Channel A
J12-13	CMD CH A-	Gearing Input Channel /A
J12-14	CMD CH B+	Gearing Input Channel B
J12-15	CMD CH B-	Gearing Input Channel /B
Shell	PE	Shield Earth Connection for 360 Bond

### Mating Connector Information

Solder cup, Metalized Shell

Norcomp 180-015-202-001 (or Equivalent)

Mating Hood/Shell: Metalized

Adam Tech DE09-HD-PN-SS (or Equivalent)



## 8.12 J13 ENCODER FEEDBACK CONNECTOR

J13, Option Card Optional Encoder Feedback is a 15-Position High Density D subminiature female (socket) connector. Connector pin out is described below with more detailed electrical information is given elsewhere in this document.

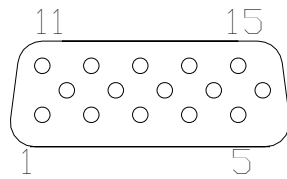

J13 Connector Pin Out		
Pin	Name	Description
J13-1	CU	Commutation track U (Hall U) Sourcing Input
J13-2	CV	Commutation track V (Hall V) Sourcing Input
J13-3	CW	Commutation track W (Hall W) Sourcing Input
J13-4	NC	No Connection
J13-5	I/O RET	5V Common
J13-6	Ch Z+	Encoder Z Channel Input (Marker, Index) Diff High
J13-7	CH Z-	Encoder /Z Channel Input (Marker, Index) Diff Low
J13-8	PTC	Motor Thermostat
J13-9	I/O RET	Motor Thermostat Return to 5V Common
J13-10	5VDC	5V Encoder Source, 200mA max
J13-11	I/O RET	5V Common
J13-12	CH A+	Encoder Channel A Input Differential High
J13-13	CH A-	Encoder Channel /A Input Differential Low
J13-14	CH B+	Encoder Channel B Input Differential High
J13-15	CH B-	Encoder Channel /B Input Differential Low
Shell	PE	Shield Earth Connection for 360 Bond

Encoder system wiring and operation can require detailed information. Not all encoder manufacturers or motors that contain encoders are all wired to the same conventions. Detailed information is provided later in this manual.

### Mating Connector Information

Solder cup, Metalized Shell

Adam Tech HDT-15-PD-RC (or Equivalent)

Mating Hood/Shell: Metalized

Adam Tech DE09-HD-PN-SS (or Equivalent)

## 9 DC INPUT POWER MODEL POWER SUPPLY REQUIREMENTS

Applicable Models: S20330-xNS, S20630-xNS

DC Unit Bus Input Power Specifications		
Bus Voltage (J1-3 to J1-2)	+ 20 VDC to + 90 VDC	
BUS Supply Current	48 VDC BUS	75 VDC BUS
S20330 Continuous	3.3 ADC at 160 W	3.3 ADC at 250 W
Peak (3 sec)	10 ADC at 480 W	10 ADC at 750 W
S20630 Continuous	6.7 ADC at 320 W	6.7 ADC at 500 W
Peak (3 sec)	20 ADC at 960 W	20 ADC at 3,000 W
BUS Output Capacitance (min)	48 VDC BUS	75 VDC BUS
S20330-xNS	4,000 $\mu$ f, 63 V	2,000 $\mu$ f, 100 V
S20630-xNS	8,000 $\mu$ f, 63 V	4,000 $\mu$ f, 100 V

### Bus Supply Characteristics

The BUS Supply should have the following characteristics:

- Must provide safety isolation from the power line
- Can be regulated or unregulated
- Bus Supply Return is connected to the Control Supply Return and I/O RTN in the drive

Typical BUS Supply:

- Unregulated, Isolating, step down transformer with secondary rectified into capacitive filter
- BUS Supply Return is connected to earth ground

### Wiring from BUS Supply to Drive

10 ft maximum  
16 AWG (minimum)  
Twisted pair  
Daisy chaining of multiple drives is acceptable  
No contactor or switching in the BUS wiring

### Control Voltage (J1-1 to J1-2)

+ 10 VDC to +90 VDC

### Control Supply Type

Isolating  
Unregulated or Regulated  
Common GND with bus supply and I/O RTN  
20 watt supply or 1 amp short circuit

### Control Supply Wiring

Wire control (J1-1) to bus (J1-3)  
*or*  
Wire control (J1-1) to separate supply to preserve status and fault information. (+ 10 VDC to + 30 VDC supply can be shared by Control and I/O)

### Control Supply Current

20 to 110 mA at 75 VDC  
60 to 330 mA at 24 VDC  
125 to 660 mA at 12 VDC

**Bus Voltage**

Bus voltage outside the operating range (20 to 90 V) causes an under-voltage or over-voltage fault. Under-voltage and over-voltage faults self clear when the fault condition clears.

**NOTE**

***Do Not allow the Bus Voltage to exceed + 90 VDC. This causes damage to the drive.***

Target design center voltage for unregulated supply is + 70 to + 75 VDC. This provides 15 to 20 VDC margin for line tolerance, transformer regulation, and regen pump up. Design center voltage for a regulated supply can be up to + 80 VDC.

**9.1 CONTROL VOLTAGE**

The control voltage range for normal operation is + 10 VDC to + 90 VDC. The control voltage can either be wired to the bus voltage so one supply can power the drive, or from a separate supply. Separately powering the control from the bus allows the bus to be powered down for safety while drive status and fault information remain available. A single + 10 VDC to + 30 VDC supply can be shared by Control and I/O.

**NOTE**

***Do Not allow the Control Voltage to exceed + 90 VDC as it can damage the drive.***

**9.2 GROUNDING**

Provide safety isolation with the external bus and control supplies from the power line.

**NOTE**

***The drive cannot be powered from an electrically Hot supply as it does not contain an isolation barrier.***

The Ctrl and Bus voltages and non-opto coupled I/O grounds (I/O RTN) are tied together inside the drive. The Ctrl and Bus power supplies share a ground pin (Bus/Ctrl Gnd). Join and connect to the negative terminals of the Ctrl and Bus power supplies. The I/O RTNs are normally connected to the signal ground of the system. (Some of the I/O is opto coupled and have separate returns. Thoroughly review this document for details.)

Earth the power supply negative terminal somewhere in the cabinet. Also earth the chassis. In normal operation, there should be no significant voltage between earth and the Bus/Ctrl Gnd and I/O RTNs.

**NOTE**

***The maximum voltage allowed between Bus/Ctrl Gnd and chassis is 100 VDC.***

**9.3 BUS CAPACITANCE**

There is a minimum requirement on the output capacitance of the bus power supply for the DC input S200. This capacitor is needed to absorb energy during motor deceleration and motor disable and to help provide energy during motor acceleration. For multiple S200 drives operated from one supply the recommendation is to increase the capacitance according to the number of drives. For example, for four 6 A / 18 A<sub>RMS</sub> DC S200 drives powered from one 75 VDC supply the recommended minimum bus output capacitance of the supply is  $4 \times 4,000 \mu\text{f} = 16,000 \mu\text{f}$ . Bus capacitor voltage rating should be 100 V. Bus capacitor type is aluminum electrolytic.

## 9.4 **BUS SWITCHING AND FUSING**

Do not put E-Stop switches or contactors between the drive bus pin (J1-3) and the power supply bus capacitor. There is a risk of damage to the drive if the bus is disconnected from the power supply capacitor when the drive is enabled. The motor does not need to be rotating to regenerate energy. The motor windings store magnetic energy that regenerates back to the supply when the drive is disabled.

E-stop switches can safely be located in series with the primary winding of a step down transformer. If individual axis E-Stop switches are required, connect a local (unswitched) capacitor (1,000  $\mu$ f, 100 V) across the drive bus terminals (J1-3 to J1-2).

If the buses of individual drives are to be fused, select the fuse type and rating for high margin.

<b>S20630 (6 amp)</b>	<b>S20330 (3 amp)</b>
15 A, Slo-Blo (Bussmann MDA-15)	7 A, Slo-Blo (Bussmann MDA-7)

## 10 DETAILED WIRING INFORMATION

Connector pin-out detail is provided in the prior section of this manual. This section deals with the details of the internal operation of the drive connections. This information is provided to allow the system designer insight sufficient to create a robust system wiring plan.

### 10.1 CABLES

#### 10.1.1 Long Cables

The DC resistance of long motor power cables steals some of the available voltage when motor current is high. The principal effect of this is some reduction in peak motor power so acceleration and deceleration times can be longer. The cable resistance has no significant effect on lower speed torque or top speed. For most applications, the loss of performance is small with cables up to the maximum cable length specification. Do not operate a DC input S200 with long cables at the lower end of the bus voltage range because too much of the available voltage is lost by the cable resistance. For AC input S200s, the DC resistance of the motor power cable is rarely an issue because the voltage drop across the resistance is usually a small fraction of the available nominal bus voltage.

For DC S200 applications with long cables and demanding dynamics, the 14 AWG cable is preferred over the 18 AWG cable. Cable voltage drop vs cable length is shown in the table below.

**Cable Voltage Drop vs Length**

Cable Length (meter)	2 x Rphase (ohm)	V line-line peak at 0.866 x 18 A <sub>RMS</sub> 18 AWG cable	V <sub>LOSS</sub> in cable as a percent of 75 V bus	
			18 cable	14 cable
3	0.126	2.77	3.7 %	1.5 %
10	0.413	9.09	12.1 %	4.8 %
25	1.03	22.7	30.3 %	12.0 %
50	(50 m not recommended with 6/18 A <sub>RMS</sub> )		N/A	24.0 %

#### 10.1.2 Custom Composite Cables

A composite cable has both feedback and power wires in one cable. One of the critical requirements for a composite cable is to provide a high degree of isolation between the power and feedback wires. For 240 VAC-connected drives, the power wires can have up to 400 V<sub>peak-peak</sub> fast switching PWM waveforms that can couple to the feedback wiring, causing communication errors between the Drive and the Smart Feedback Device (SFD).

Danaher Motion has developed and sells a composite cable that has very good isolation between the power and feedback sections. It is strongly recommended that this raw cable be used for custom composite cable designs. Contact your Danaher Motion sales representative for additional information. If this cable does not meet your specifications, the following are some guidelines for custom composite cable development. ***Due to the complexity of modeling and understanding cable coupling, a new composite cable needs to be prototyped and tested to have confidence that it will be reliable.***

**Composite cable should have double concentric feedback shields – one shield within another.**

The raw composite cable that has been tested and is known to work well with the S200 has the following structure: *double, concentric shields* around the feedback wires plus an outer shield around the whole cable (see diagram below). This type of raw cable is strongly recommended. Testing shows double, concentric, shielding is ten times better than single shielding at reducing coupling from the power wires to the feedback data wires.

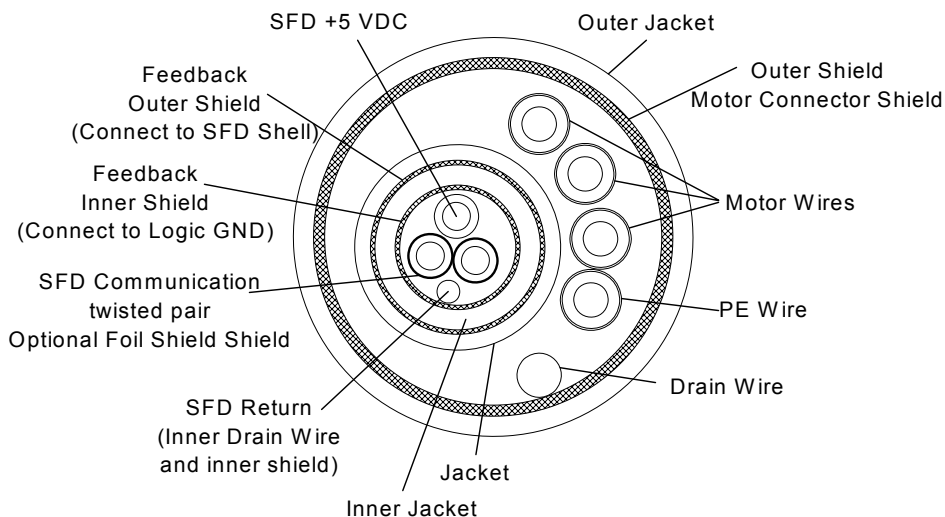

### Composite Cable Cross-Section

There can be substantial capacitance between the power wires and adjacent feedback shield in a composite cable. Some of the PWM ampere level spikes tend to return in this adjacent shield. In effect, the power stage voltage and current *drive* the feedback shield nearest to the power wires. In a single-shielded feedback cable this *driven* shield is also around the feedback data wires, so some coupling can occur. With double, concentric feedback shields, the *driven* shield is the outer of the two feedback shields, and interposed between the *driven* shield and feedback data wires is the inner feedback shield. Typically, the inner feedback shield is isolated from the connector shells and connected to the return for the power supply powering the feedback device.



NOTE

***A raw cable with two pairs of twisted, shielded feedback sections inside a composite cable is electrically the same as single feedback shielding. There may physically be two feedback shields in such a cable, but these shields are not concentric. There is only one shield between the power wires and feedback wires, where with double, concentric feedback shields, there are two.***

### SFD +5 and Gnd Resistance Spec

To insure that the SFD + 5 voltage at the SFD inside the motor is within specification, the voltage drop total in the SFD + 5 V wire and SFD + 5 V RTN wire must not be greater than 0.5 V at 150 mA. For this reason, a cable requirement is that the total resistance of the feedback SFD + 5 V wire plus SFD + 5 V RTN wire must be  $< 3.33 \Omega$  (at 20° C). In practice, this means that for long cables, the AWG wire gage needs to be considered.



NOTE

***The inner shield of the a double, concentric feedback cable, when isolated from the terminating connector shells, can also function as a conductor to carry some or all of the SFD + 5 V RTN current. This is useful to keep the total SFD + 5 and RTN resistance within specification on long cables without having large diameters.***

### Feedback Characteristic Impedance

Danaher Motion's S200 feedback cables are designed to have a feedback data pair differential impedance of 81  $\Omega$  (at 1 MHz). Impedances in the range of 50 to 100  $\Omega$ , while not tested, will likely work properly with the S200.

Purchase a Danaher Motion-built composite feedback cable, review its construction, and test its performance. There are many ways to connect the multiple shields of a composite cable. A good way to understand how the Danaher Motion composite cable is built is to buy a short Danaher Motion S200 composite cable, open it up, and see how the shields at both the motor and drive end are connected.

## 10.2 DEFINITIONS DISCUSSION

Bred from the older days of PLCs and the newer days of digital logic some words have become standard in some industries. Some terms are described here to make this document easier to understand:

**Common Rail:** Common rail is simply a term meaning that more than one input (or output) has one terminal of its device tied to the other inputs (or outputs). An example of a common rail is shown below:

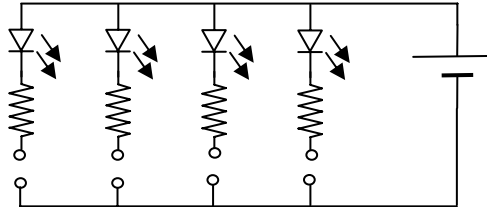

Figure 8.1 Common Rail Illustration

In Figure 8.1 each input is represented by the LED. Each input has a common connection (Anode) to the positive side of the I/O power source. This is what is referred to as a common rail. It is also allowable to modify this circuit where each anode goes to the switch and each resistor is tied to the negative side of the I/O supply.

**Sourcing Input:** A sourcing input is an input that must be taken to ground to operate. (It SOURCES current). The above figure shows discrete inputs arranged for sourcing. These are used with sinking output device such as Open Collector drivers. Some manufacturers of driving devices refer to sinking outputs as 'NPN' devices after then name of the driving device transistor type.

**Sinking Input:** A sinking input has the opposite arrangement of sourcing inputs where a current-to-ground must be supplied to the input. (Sinking current to ground). These are used with sourcing output devices. Some manufacturers of driving devices refer to sinking outputs as 'PNP' devices after then name of the driving device transistor type.

## 10.3 PE EARTH GROUND CONNECTIONS

It has been noted throughout this manual that a connection to earth ground is required. Multiple connections may be required. The connection to earth ground can affect safety and electrical noise immunity and emissions. The purpose of this text is to alert the user to the requirement of the earth ground connection. When connecting earth grounds it is often required to have a connection that can not come undone so ring lugs to the frame is highly recommended. Each earth ground wire should go directly back to the central earth ground block in the cabinet; do not daisy-chain the connections. Large gage wires consisting of many fine strands of wire are superior to other types for conducting high frequency noise and the use of high strand count wire is recommended.

## 10.4 SERIAL PORT WIRING

Connector J5 is the RS232 Serial Port. Danaher Motion offers a pre-made serial communications cable P/N P7S2-232-D for direct connect to a computers 9-pin serial communications port. The following information is supplied for applications choosing to not use this cable.

While some computers may vary in the actual pin-out most computers have followed standardizing these connections. The following diagrams are provided for standard 9 pin and 25 pin Subminiature D-type connectors provided on most computers. Many HMI/OIT manufactures have chosen to swap pins to allow the cable to be made pin-for-pin. Always consult the manufacture's recommendations before wiring these types of products.

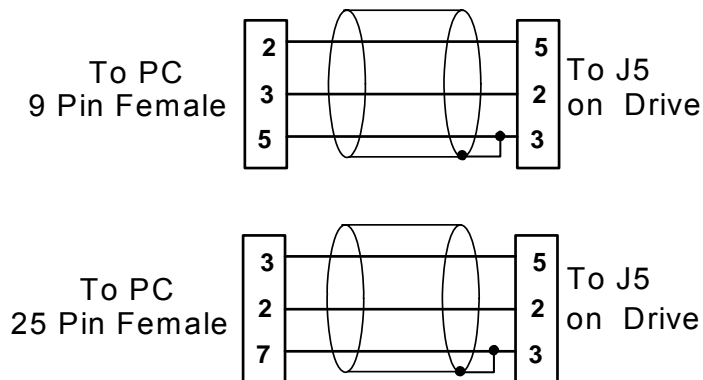

## 10.5 WIRING DISCRETE DIGITAL INPUTS

The discrete digital inputs are DINP1-10. This section discusses wiring of inputs DINP1-4, and 6-9. Digital inputs 5 and 10 are different than the rest and will be covered in the next section.

DINP1-4 and 6-9 are available on J4 and J12 and are identical sets of 4 inputs on each connector. These inputs are bipolar common rail inputs rated for operation from 4 to 30 Vdc. Common rail means that each one of the set-of-four have one pin each tied together to come out of the drive as one pin. Bipolar means that the input will function regardless of the connection polarity.

Input DINP1 is a dedicated hardware enable and it must be asserted to get the drive to enable the motor. DINP2-DINP10 are user configurable but have default assignments as listed in the S200 Position Node User's Guide. Inputs can be wired for sourcing or sinking devices.



## 10.6 TYPICAL WIRING WITH SINKING SWITCHES:

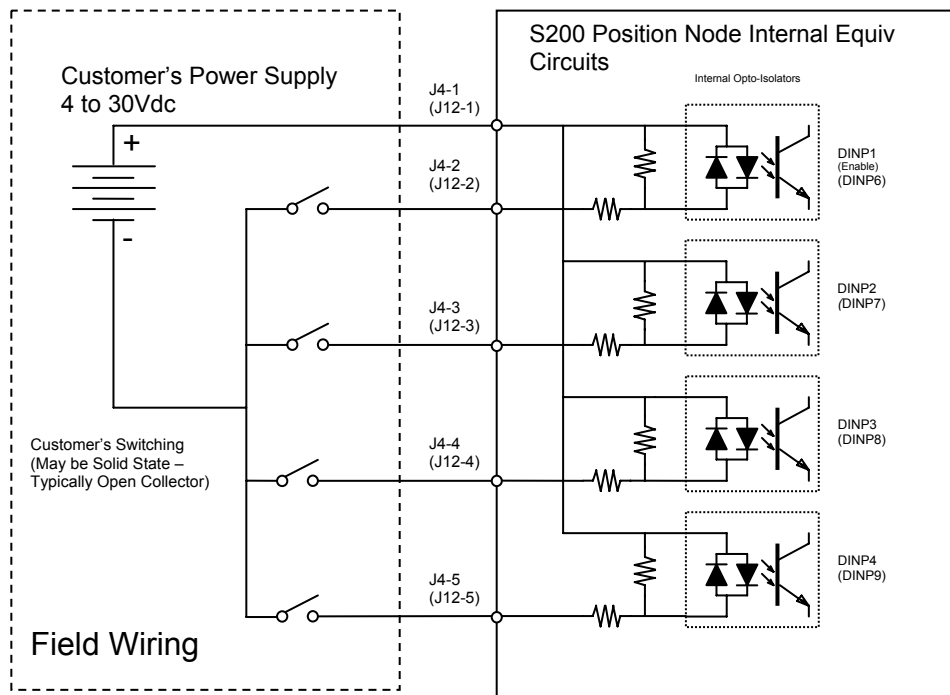

In the above diagram the switches conduct electrical current through the S200 PN inputs to ground. Many interface devices encountered in machine control use solid-state switches that are commonly NPN transistors.

## 10.7 TYPICAL WIRING WITH SOURCING SWITCHES

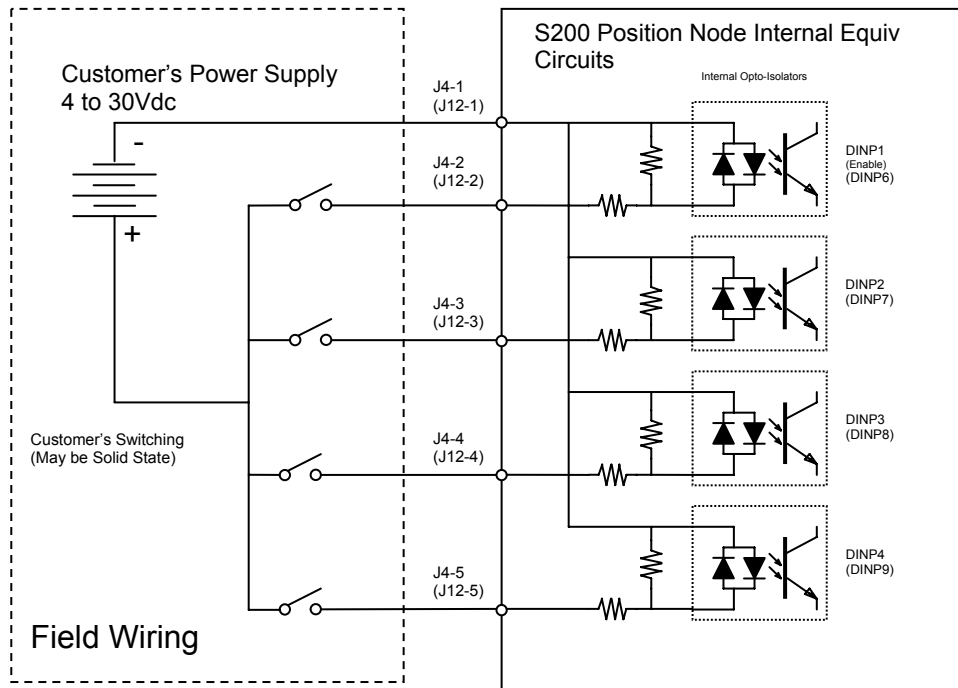

The above diagram shows typical wiring for Sourcing switches. The Switches supply the source of current through the S200 PN input. These devices may be solid state and are sometimes called PNP devices.

Current drain for the inputs is identified in the following table.

Input Voltage ( $\pm$ )	Input Current ( $\pm$ )
4.0 volts	0.65 mA
5.0 volts	0.95 mA
12 volts	2.5 mA
24 volts	5.3 mA
30 volts	6.7 mA

## 10.8 WIRING DINP5 AND DINP10

As noted DINP5 and DINP10 are high speed opto-isolated input devices that do not have a connection to a common rail. They are designed for 5 volt operation and the polarity of the power supply used is critical for functionality. Not having a common rail connection the inputs can be wired for sourcing or sinking according to the need of the application.

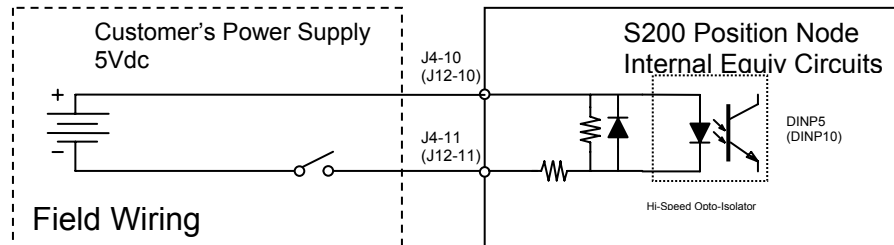

For systems desiring to use input voltages exceeding the 5V rating for DINP5 and DINP10 an external current limiting resistor must be used. The resistor should be in series with the input line. The following table indicates the recommended resistor values.

Supply Voltage	Resistor Value
3-6V	No Resistor
12V	470 Ohm ¼ Watt
24V	1200 Ohm, ½ Watt

## 10.9 WIRING DISCRETE DIGITAL OUTPUTS

The S200 Position Node has 3 outputs; Fault, /Run, and one user-configurable. These outputs can handle no more than 50mA current and no higher than 30Vdc circuit design. Each output is 'uncommitted'. That term simply means that both pins of each output are user-wired, not tied to a common rail. The purpose for this is to allow greater flexibility in the end application. The outputs are solid-state transistors and are polarity sensitive: Proper polarity must be observed. All three outputs are electrically identical.

**Fault Output:** The fault output is a dedicated normally closed output for user use. This means that the output is in the on state when no fault is present. If a fault is detected the S200 PN will turn this output off. This method is considered fail-safe in that many failure modes of this circuit will cause the host to detect a fault.

**Run Output:** The Run output is a dedicated normally closed output for user use. This means that the output is in the on state when the S200 PN is ready to run. Internally, the Run output is conceptually equivalent to the Power Stage Enable line. If the power stage is enabled the output will be on. If the user disables the drive, either by hardware or software disable, or if the drive detects a fault and shuts down the power stage then the output will open. This logic is typical of systems requiring holding brakes.

**User Configurable Output:** The S200 Position Node User's Guide has information regarding the function of this output.

Typical wiring configurations of any of these outputs are either direct logic connection back to a host controller or to a relay. The following diagrams show typical wiring configurations.



**Connection of any inductive load, such as a relay coil, must use diode suppression across the coil to prevent excessive voltage kick-back at turn off. Outputs are not overload protected. Do not exceed maximum rated current.**

Wiring Discrete Output to LED or Opto Isolator

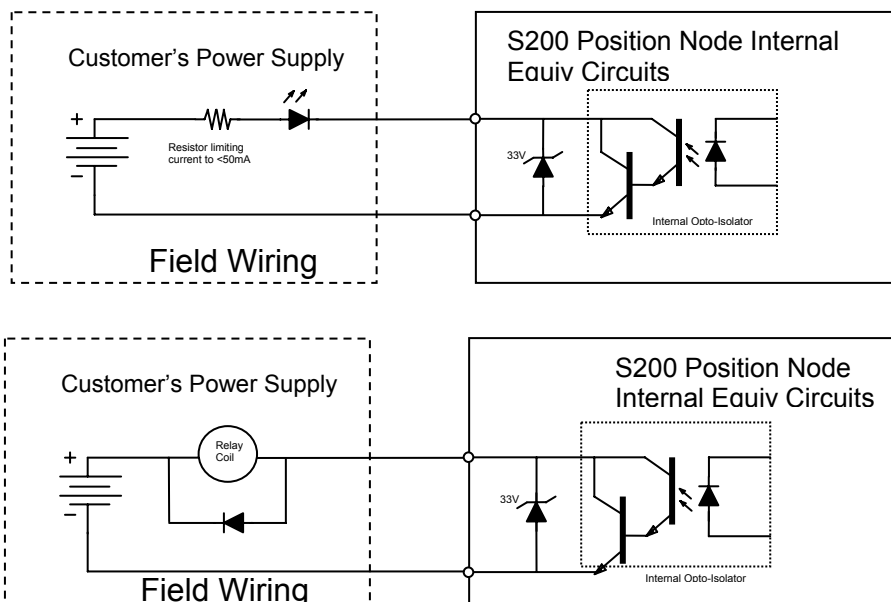

The above diagrams are applicable to systems implementing a solid-state load or relay connected to an S200 PN output. Load LED and resistor or relay coil (reverse diode) can be in either leg of the power circuit.

## 10.10 USING THE DAC MONITORS

The S200 PN has two analog outputs for use by the customer at J4. Each has a list of possible assignments and a default value as listed in the S200 Position Node User's Guide. The DAC (Digital to Analog Converters) are OPAMP (Operational Amplifier) outputs and care should be taken to assure noise-free signal reception. The range of each monitor is 0.5Vdc to 4.5Vdc and have an internal source impedance of 2k ohms. This internal impedance limits to short circuit current to 2mA and can be a source of signal attenuation if too much load is drawn from these outputs. These outputs are intended to feed instrumentation such as an Analog input to a host or an oscilloscope for function monitoring. Each DAC Monitor output supplies a single-ended output voltage referenced to the I/O RTN pin. The use of shielded, twisted pair wire is recommended if these circuits are to be wired to another device. The shield should be tied to the frame of J4 at the drive and the frame of the receiving equipment.

## 10.11 WIRING ENCODER OUTPUT SIGNALS

Available at J4 for the customer's use are encoder equivalent output signals. These signals provide incremental encoder performance for the motor driven by the S200 PN and can be used by a host controller or monitor. The signals are differential driven and are RS-485 / RS 422 compliant. The use of terminating resistors at the receiving end (120 ohm) is recommended. The output drivers are short-circuit protected. The encoder resolution can be adjusted by switch S1 at the top of the drive or by the S200 OC Tools software. Refer to the S200 User's Guide for setup information on the resolution of the output.

Wiring for these signals should be done with individually twisted/shielded pairs. Shields should be tied at the frame of J4 at the S200 PN and at the frame of the receiving equipment. An additional wire to tie the two system's DC common together is highly recommended to prevent damage from ground-shift spikes. Tie the connection to any I/O RTN pin on J4 at the S200 PN.

## 10.12 MOTOR WIRING

Good motor wiring practice is a must when applying any PWM controlled servo motor drive to the motor. The S200 PN uses PWM voltage control to the motor. The frequency of the PWM may vary according to the model number. PWM systems switch high voltage at very fast rates. This voltage switching creates fast edged on the voltage signals traveling down the motor cable to the servomotor. This switching voltage can couple capacitively in both the cable and the motor creating high frequency current flows that must be controlled. Danaher Motion offers highly engineered cables to provide the best control of these signals.

Should the user decide to wire the motor there are a few important recommendations that should be followed:

The motor cable must have a separate conductor that carries the motor frame back to the S200 PN's PE terminal designated for the motor cable.

Chosen cable should be at least 600V rated and should have relatively low capacitance. The motor cable should have >90% shield coverage and the shield should be of braided design, not foil. The cable shield should terminate, along with the motor case wire, to the S200 PN's PE terminal designated for the motor cable at the drive end and to the connector housing at the motor with a 360-degree bond attachment.

Motor cables should be uninterrupted from the drive to the motor. In case where this is not practical the motor cable connection should be made with a connector type that allows 360 degree shield coverage so that the cable shield appears uninterrupted.

Appendix A has more information on installation practices that allow for trouble-free installation. Please read that section before proceeding.

## 10.13 REGEN RESISTOR WIRING

Applicable Models: All AC Input units.

Many applications do not require the use of a regen resistor. Danaher Motion's Motioneering software can predict the need for a regen resistor. There is also an application note on the Danaher Motion website ([www.DanaherMotion.com](http://www.DanaherMotion.com)) providing the equations to calculate the regenerative levels. Nuisance over voltage tripping is the symptom indicating the need for a regen resistor. Danaher Motion offers the ERH-26 regen resistor compatible for use meeting all the requirements of the S200 Position Node product line.

Connection for an optional regeneration power resistor to absorb regenerated energy from the motor is provided on each S200 Position Node. If the ERH-26 is not used then the user should choose a wire-wound resistor with 1500 V<sub>RMS</sub> isolation between terminals and case. The regen resistor must not have a lower ohm value than specified for the given drive. The power rating of the regen resistor depends on the amount of regenerated energy that needs to be dissipated. In many applications there is little need for an aggressive low-ohm value resistor. The chosen resistor must be self-protecting against overheating failure. This can be done any number of ways including; thermal snap action fuse protection, a series thermal overload heater relay, or with a resistor value that can limit the maximum wattage to the rating of the resistor. Any protection using contacts would have the switch wired into a safety circuit that shut down the system in the event of a resistor over temperature to prevent a fire hazard.

Wiring to the regen resistor should be short and the leads should be twisted together. Although never required, in systems with sensitive electronics it is not uncommon to shield these wires with a braided cable with shields tied to earth at both ends. Thermal overload protection is wired into the machine safety circuit such that it causes a machine shut-down upon sensing excessive regen resistor temperatures.

## 10.14 STEP AND DIRECTION OR ELECTRONIC GEARING WIRING

The S200 Position Node has the ability to accept position commands from an external source in the form of pulses. Typical systems use one of two devices for this command; incremental encoder signals or step (pulse) and direction signals. The S200 PN electrical input circuits for these signals uses differential line receivers and resistor biasing to allow use with differential line transmitters, open collector, or TTL driver circuits. The circuit arrangement is shown in the following diagrams. Due to this circuit design it is very important to tie the DC Commons of the two systems together.

Incremental encoder signals are typical of systems that are used as a gear-follower, some times called master or line-shaft. Details of how these systems work can be found in the S200 Position Node User's Guide. The basics are that an encoder signal (A/B differential) is wired into the S200 PN's J12 connector. These signals are translated into quadrature pulses that increment or decrement the internal position loop command register, subject to acceleration and deceleration limits. The S200 PN has no use for an encoder Z (marker or index) channel for these applications. The source of these signals can be either another controller with encoder outputs or a stand-alone incremental encoder. A 5V supply is available at J12 as a power source for the stand-alone encoder.

Typical interconnect is presented below.

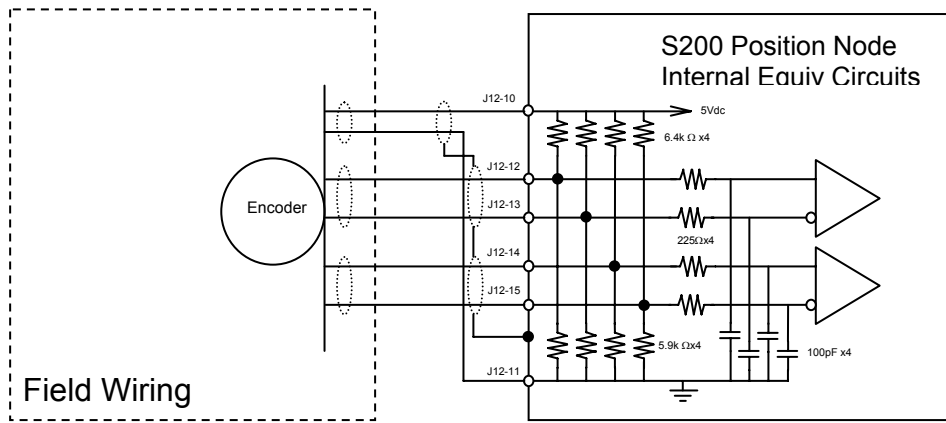

For systems desiring TTL interface, TTL outputs would be tied to A and B while leaving /A and /B not connected. The DC Commons must be tied together. Open collector interface is shown below.

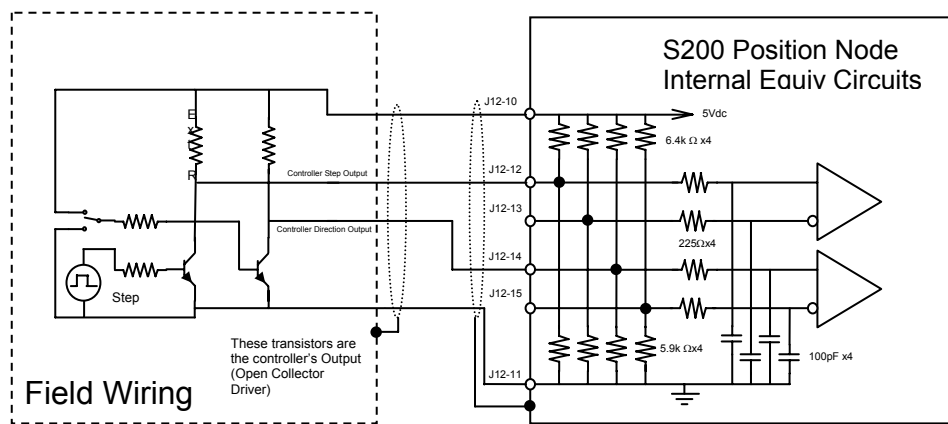

The above circuit shows a generic interface using open collector drives to drive the encoder input signals of the S200 PN. Several manufacturers of PLC with step and direction output use this method. Note the required use of pull up resistors.

## 10.15 ENCODER MOTOR FEEDBACK

The following diagrams indicate how to wire an encoder feedback to the S200 Position Node drive. The information provided pertains to Danaher Motion AKM Series motors. Other motors or encoder manufacturers may use different conventions when naming signals. Danaher Motion can not be responsible for the differences but a phasing diagram and some explanations are provided to help the user determine the proper wiring and setup for other component suppliers.

The AKM motor wiring is provided below in both schematic and tabular form.

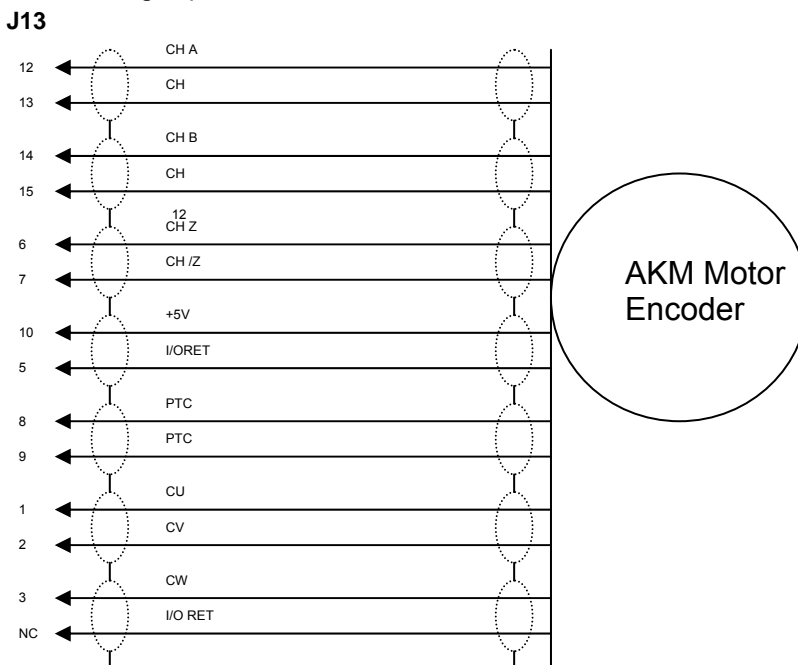

Signal Name	Drive Pin# On J13	AKM 'C' Option Pin #	Motor Wire Color	AKM 'M' Option Pin #	Description
CU	1	15	BRN	15	Open Collector U Channel commutation input
CV	2	16	GRY	16	Open Collector V Channel commutation input
CW	3	17	WHT	17	Open Collector W Channel commutation input
NC	4	-	-	-	No connection
I/O RET	5	7	BLK	7	Signal common for 5V supply from drive
Z	6	5	VIO	5	Z channel (Also called Marker or Index) to drive.
/Z	7	6	VIO/BLK	6	Z Complement (Differential driver) to drive.
PTC	8	8	ORG	8	Motor Thermostat (Active Open)
PTC RET	9	9	ORG/BLK	9	Motor Thermostat Return (Common)
+5VDC	10	10	RED	10	+5V Source from drive for encoder power.
I/O RTN	11	-		-	Additional 5V source return common.
A+	12	3	BLU	3	A Data Channel Input
A-	13	4	BLU/BLK	4	A Channel complement (Differential driver)
B+	14	1	GRN	1	B Data Channel Input
B-	15	2	GRN/BLK	2	B Channel complement (Differential driver)
Case	Case	-	Shell	18	Cable shield connections. Normally connects the back shell on both ends of the cables. (Molex does not have a back shell so pin 18 is used).

Motors using incremental encoders used with the S200 Position Node must provide hall emulation commutation tracks in with open collector drive circuits. The alignment of the commutation tracks to the motor's back EMF (magnetic alignment) is critical. The following phase diagram will indicate the proper alignment. S200 OC Tools and the S200 PN support a phase offset adjustment when the hall tracks cannot be properly aligned but the actual determination of the correct offset is by trial and error. The basic procedure is not discussed other than to say that the phase is correct when the motor's actual output torque is balanced in both directions for a given command.



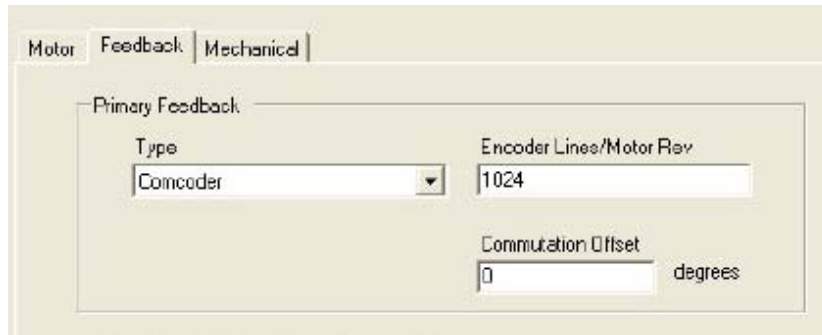

The following phasing diagram can be helpful when using motors other than Danaher Motion's AKM Series with encoder feedback.

### COMMUTATING ENCODER

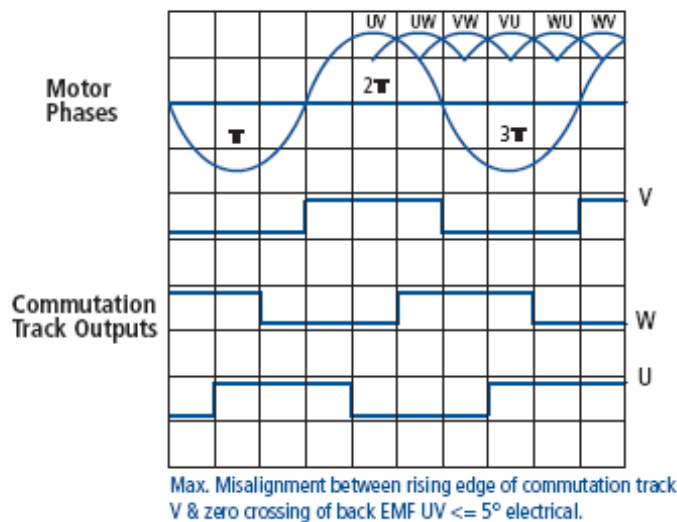
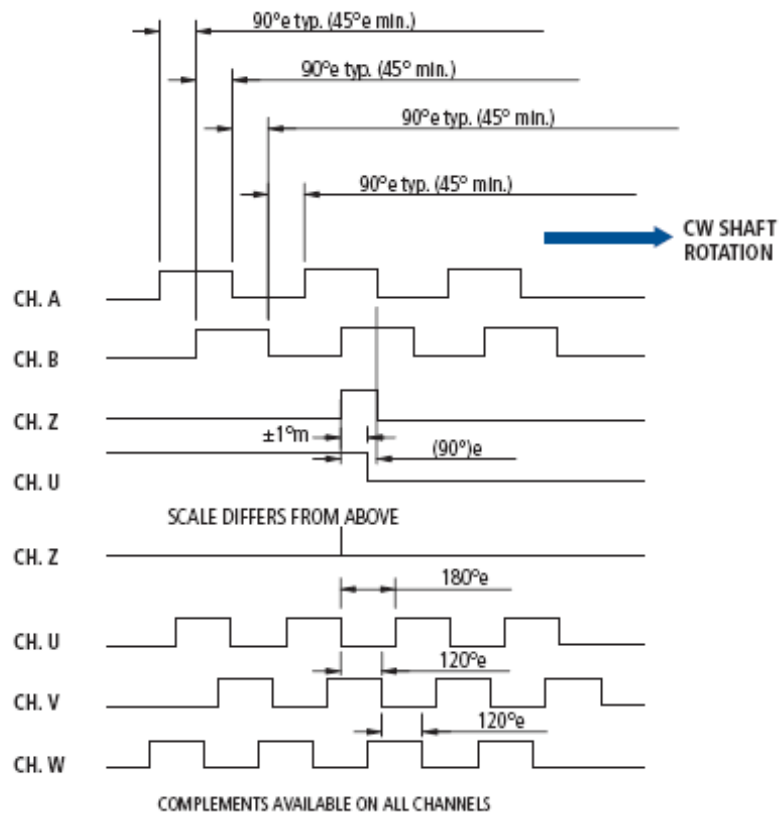

# 11 SYSTEM STARTUP

The companion S200 Position Node User's guide has information pertaining to installation and use of the User Interface Program (GUI) called S200 OC Tools. The following startup recommendations assume that the user has the GUI installed on the computer for test and setup and that it is appropriately connected via RS232 communications.

## 11.1 WIRING CHECKS

Before applying any power please double check all wiring for accuracy and quality. Wiring should be done to local and national wiring standards. In addition please ensure the following:

Earth ground must be connected to all PE terminals and the Screw block on the front of the S200 Position Node.

Signal wires (low voltage) must be separated from power wires (high voltage).

All terminals should be torqued to appropriate specifications

No wire strands should protrude from any connection.

## 11.2 SWITCH SETTINGS

The S200 Position Node has several user-settable switches. The function of these switches are defined in the S200 Position Node User's Guide. Default settings of these switches will support the installation and startup procedures in this document. These switches affect CANbus baud rate, Modbus and CANbus address assignment, and encoder equivalent output resolution. If the user finds any of these to be adjusted as part of a comprehensive startup procedure then the S200 Position Node User's Guide should be referenced at this time.

## 11.3 APPLY CONTROL POWER

Apply control power only to the S200 Position Node. Note the following:

- The green status LED to the left of J5 should flash at 2 Hertz (500ms on / 500ms off).
- The 7 Segment display should flash a sequence indicating the drive model number. For example, an S20360 drive will flash 'b'-S'-2'-0'-3'-6'.
- That flash should be followed by a steady 'd' in the display indicating that the drive is disabled.

A display of anything other than described above is probably a recognized fault condition. See the S200 Position Node User Guide for further information pertaining to fault and corrective actions.

If an AKM motor with SFD feedback is used nothing more need be done at this time. If an encoder based motor is intended to use the commutation encoder for feedback then the startup process must continue with the following encoder checks:

The importance of the position feedback counting up for motor shaft CW (Looking at the load-end of the motor) is extremely important. Do not proceed if this is not the case.

Under the S200 OC Tools GUI select the Motor and Mechanical \ Feedback form. Select the Feedback type as COMCODER. Enter the encoder line count. Go back to the status screen and note the Position Feedback number. Rotate the encoder (motor) one revolution CW. The new Position feedback number should be approximately equal to the previous feedback position plus 4 times the encoder line count.

Since the AKM with SFD feedback device automatically loads all the motor parameters but is not present on these systems, all motor data sheet parameters must be manually entered using the S200 OC Tools GUI. Under the Motor and Mechanical Setup \ Motor tab: Search the Motor selection box to see if your motor is located in the GUI database. Select it if it is and the correct settings will be loaded. If the motor does not exist than it must be manual entered using the Utilities\Motor Database Editor menu. Select ' New Motor, enter the data, then Add. Exit the database and return to the Motor and Mechanical Setup \ Motor form and select the newly added motor.



**All drive configuration settings made in the previous steps must be saved to non-volatile memory or the settings will be lost upon power cycle. Use the Save to NV button to accomplish this.**



## 11.4 CONTROL WIRING CHECKS

System wiring varies greatly from application-to application. The following section is a rough guideline as to what to look for.

- Using S200 OC Tools the Status form should indicate that the System status is 'Drive OK'.
- While S200 OC Tools has the Status form up on the computer screen the 'Position Feedback' box is updated 'pseudo real time'. Rotating the motor shaft by hand should cause this position to count upward. If the position does not count upward the chances are that the system is using an encoder feedback device that is incorrectly wired.
- Each discrete input wired to the S200 Position Node can be activated and the Status screen will illuminate its associated 'LED' (radial light button) accordingly. Check all input wiring in the manor.

## 11.5 ADDITIONAL SAFETY CHECKS



The next steps will allow motor motion. Care must be taken to allow the motor to move freely without any possibility of damage to equipment or personnel. The motor should be mounted or clamped in a way that will prevent jumping if exposed to high acceleration rates.

## 11.6 APPLYING BUS POWER

Assure that the hardware enable (DINP1) is inactive. Apply bus power. Note for anything suspicious such as noises, sparks, or smoke.



Nothing is expected to happen at this point. Ensure that no faults have been detected and annunciated in the status display. Immediately kill power if anything other than what is described here occurs.

Enable the drive by activating the hardware enable (DINP1). The motor should not move. A slight high frequency noise is common but not required.

Note: Along with the hardware enable line (DINP1) there is also a software enable feature. Nothing in this procedure, short of a fault, would cause a software disable. However, part of the drive setup allows the user to configure the drive to power up software disabled. If the drive has not seemed to enable power to the motor at this point then please use the GUI to ensure that the drive is enabled.



The above picture of the GUI keys indicates that the drive is software disabled and ready to accept an 'EN' command to software enable it.

## 11.7 MOTOR MOTION CHECKS

Using S200 OC Tools click the mouse on the jog buttons and confirm controlled motor motion. Clicking on an arrow causes motion in that direction. Moving the mouse away from the arrow stops motor motion. Check both directions.

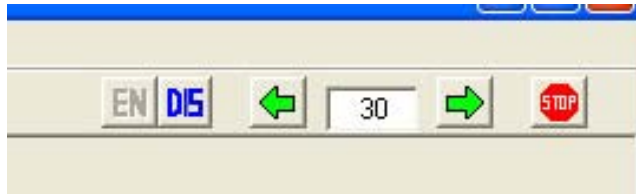

Motion control from the GUI is available as indicated in the above screen shot. The drive can be disabled, Jogged CCW or CW. The jog speed (30 RPM) can be changed, or the motor can be stopped.

Note: The difference between the DIS and STOP functions is that the DIS disables the power stage allowing the motor to coast to a stop. The STOP input initiates a deceleration to 0 speed but does not disable the drive's power stage.

## 11.8 SYSTEM TUNING

Remove all power to the system. At this point the motor may be coupled to the load and the system may be tuned. See the S200 Position Node User's guide for more information on system tuning.

## 12 REGULATORY INFORMATION

### 12.1 CONFORMANCE REQUIREMENTS

The equipment described herein has been developed, produced, tested and documented in accordance with the corresponding standards. Use conforming with requirements means that the safety recommendations and warnings detailed in this manual are complied with and that the applicable regulations for safety (machine directives, etc.) and noise suppression (EMC Directives) are observed while operating the drive. At the end of its lifetime, dispose of or recycle the drive according to the regulations applicable at that time.

### 12.2 UL AND cUL CONFORMANCE

The S200 drives are UL and cUL Recognized to UL 508C under UL File number E137798. Consider the following points to ensure that final installation meets UL requirements:

- The drive should be used within its specified ratings.
- The drive should be mounted in the intended manner in an enclosure having adequate strength and thickness with acceptable spacings for the end product classification.
- The spacings from the exposed live-metal parts to the enclosure wall should be in accordance with the requirements for the overall equipment.
- These drives shall be used in a pollution degree 2 environment in order to comply with the spacing requirements of UL 840 and UL 508C.
- The UL temperature tests were done with a metal heat plate with overall dimensions, 6 in x 12 in x 1/8 in. The machine builder is responsible for ensuring adequate heat sinking capability in the final installation.
- The thermal protective device(s) provided integral to the motor drives were not evaluated by UL.
- The terminals are suitable for factory wiring only.
- These motor drives have not been evaluated to provide solid-state overload or over speed protection.
- The DC models were evaluated by UL for use with an isolated power supply rated no more than 150 V open circuit secondary voltage and 10 kVA secondary power. This combination shall be maintained to satisfy UL requirements.

### 12.3 CE APPROVAL

The CE initials confirm that the S200 drives satisfy all requirements of CE Directives. However, the equipment is not ready to operate without additional installations (cable, motor, etc.). Thus, all necessary tests and measurements had to be made on a typical installation. The test installation with all peripheral devices, as well as the test results and measurements are recorded in detail in documentation that is available from the manufacturer on request.

### 12.4 CE EMC COMPLIANCE



If the connection method on your machine is different from the ones pictured in this manual, or in the event of use of components other than those specified, adherence to CE interference limit values cannot be guaranteed.

The machine builder should incorporate good EMC installation and wiring practices in the machine design. Some machine designs require more EMC consideration than others. For example, a multi-axis machine generates more noise than a single-axis machine. Therefore, multi-axis machines may require additional noise reduction techniques, such as a metal enclosure or clamping of cables shields to an RF ground.

## 12.5 CE TEST SETUP

### AC MODELS S2XX6X-VTS

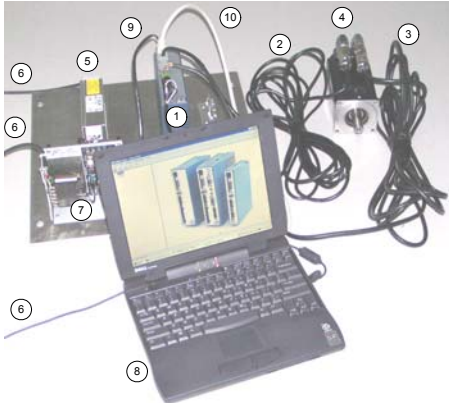

- 1) **S200 AC DRIVE:** S20360-VTS
  - 2) **MOTOR FEEDBACK CABLE:** CF-DA0111N-05-0 (CF-DA0111N-50-0 for conducted emissions)
  - 3) **MOTOR POWER CABLE:** CP-102AAAN-05-0 (CP-102AAAN-50-0 for conducted emissions)
  - 4) **MOTOR:** KOLLMORGEN AKM43K-ANCNC-00
  - 5) **LINE FILTER:** MTE RF30006-4 (see \* below)
  - 6) CORDS FOR AC MAINS CONNECTION
  - 7) 5V POWER SUPPLY FOR ENABLE OPTO
  - 8) PERSONAL COMPUTER
  - 9) SERIAL CABLE (for setup and diagnostics)
  - 10) SHIELDED I/O CABLE WITH DSUB SHELL GROUNDED AT EACH END
- \* (cable between filter and drive shielded with shield tied to PE with a 360 degree termination at each end of the cable)

## 12.6 CE TEST SETUP

### DC MODELS S2XX3X-VTS

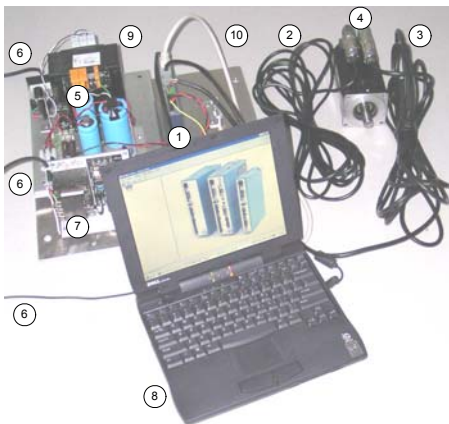

- 1) **S200 DC DRIVE:** S20630-VTS
- 2) **MOTOR FEEDBACK CABLE:** CF-DA0111N-05-0 (CF-DA0111N-50-0 for conducted emissions)
- 3) **MOTOR POWER CABLE:** CP-102AAAN-05-0 (CP-102AAAN-50-0 for conducted emissions)
- 4) **MOTOR:** KOLLMORGEN AKM43K-ANCNC-00
- 5) SAFETY ISOLATED DC BUS POWER SUPPLY
- 6) CORDS FOR AC MAINS CONNECTION
- 7) 5V POWER SUPPLY FOR ENABLE OPTO
- 8) PERSONAL COMPUTER
- 9) SERIAL CABLE (for setup and diagnostics)
- 10) SHIELDED I/O CABLE WITH DSUB SHELL GROUNDED AT EACH END

## 12.7 DECLARATION OF CONFORMITY

In our Declaration of Conformity, we affirm our compliance with Directive 73/23/EEC (Low voltage Directive) and with Directive 89/336/EEC (EMC Directive).

For the S20260-VTS, S20360-VTS, S20330-VTS, and S20630-VTS, EMC testing was done according to EN61800-3:1997 with the incorporation of amendment A11:2000 (Emission limits according to chapter 6.3.1 of that regulation, First environment / restricted distribution).

During assembly of our product in a machine, startup (that is, normal operation) is prohibited until the end-product complies with Directive 89/392/EEC (Machine Directive) and directive 89/336/EEC (EMC Directive). The machine manufacturer must prove that the complete system conforms with all relevant European Directives.

Drive conformance to specified standards is certified by the Declaration of Conformity in this manual.

### CE Declaration of Conformity

This is to certify that: Kollmorgen Industrial Drives  
201 Rock Rd  
Radford, VA 24141

Declares that the product(s):

Designation DIGITAL SERVO DRIVE

Type S20260-DNS, S20360-DNS, S20330-DNS, S20630-DNS,  
S20250-DNS, S20350- DNS, S20260-CNS, S20360-CNS,  
S20330-CNS, S20630-CNS, S20250-CNS, and S20350-CNS

comply with the following relevant regulations:

CE Guideline 72/23/EEC Low Voltage Directive

Applied harmonized standards: EN 50178: 1998

CE Guideline 89/336/EEC EMC Directive

Applied harmonized standards: EN 61800-3:1997

Manufacturer's Contact: Peter Deneault, Compliance Engineer  
Danaher Motion GPS North America  
Pacific Scientific

Issued By: Steve McClellan, Engineering Services Director  
Danaher Motion GPS North America  
Kollmorgen Industrial Drives

Place, Date: Radford, VA, USA 03/15/2005

Legally binding

Signature



## 12.8 INSTALLATION AND COMMISSIONING

Installation and wiring of the drive must be completed only by qualified personnel having a basic knowledge of electronics, installation of electronic and mechanical components, and all applicable wiring regulations.

Only qualified personnel having broad knowledge of electronics and motion control technology are to commission the machine utilizing the drives.

This manual should be read in its entirety. This appendix contains important regulatory information not necessarily covered in earlier chapters. The material in this section should be taken into consideration to ensure compliance with applicable regulatory requirements. This section alone does not contain all the information needed to install and operate an S200 drive. General information on installation and wiring are explained in detail in previous sections.

## 12.9 EUROPEAN COMPLIANCE

In Europe, these include:

- DIN - EN 60204 - Part 1, instructions relative to electric equipment in machines for industrial use.
- DIN EN 50178, instructions relative to electronic equipment for use in power installations.

## 12.10 LOW VOLTAGE DIRECTIVE AND EN50178

To ensure compliance with the Low Voltage Directive and EN50178, following these requirements:

- Electronic drives contain electrostatic sensitive devices, that can be damaged when handled improperly. Qualified personnel must follow ESD protection measures. For example: wear grounded heel and wrist straps when contacting drive.
- The climatic conditions shall be in accordance with EN 50178 climatic class: Type B, temperature and relative humidity: Class 3K3.
- The drives shall be installed in an environment of Pollution Degree 2 or better.
- The S200 drives are not considered portable and are to be mounted in the intended manner in a motor/control cabinet having adequate strength and thickness with acceptable spacings for the end product classification accessible by qualified personnel only. The enclosure/cabinet shall meet at least the requirements of Protective Type IP2X according to 5.1 of EN 60529. If the top surface of the enclosure/cabinet is easily accessible it shall meet at least the requirements of the Protective Type IP4X.
- Care shall be taken to ensure that the larger device or enclosure that accommodates the built-in device provides protection against direct contact.
- The S200 drives may be erected in closed electrical operating areas if a protection against direct contact is available or assigned for by means of obstacles and/or a distance according to IEC 364-4-412.3 and IEC 364-4-412.4.
- Follow IEC 536-2 and IEC 1140 for installation protection against electric shock.
- Installation shall be performed in accordance with local electric codes, local accident prevention rules, EN 50178 and EN 61800-3.
- Never connect or disconnect any drive connectors or terminals while the power is switched on.
- Due to high leakage current, permanently install this drive (hard wired or fixed type). The PE connection shall be made by two separate protective conductors satisfying the requirements for protective conductors as given in 543 of HD 384.5.54 S1 between the earth ground and the PE terminal(s) on the drive, or by a protective conductor having a cross section of at least 10 mm<sup>2</sup> Cu. The S200 drives are designed to Protective Class I.
- The discharge time for the bus capacitors may be as long as 5 minutes. After disconnecting the drive from the ac mains be sure to wait 5 minutes before removing the drive's cover and exposing live parts.
- The finished installation shall comply with the requirements of the IEC 364-4-41 series of standards.
- The cables and leads (except the protective conductors) used in the erection of the S200 in an installation which are accessible for contact without opening or removing a barrier or are laid on extraneous conductive parts shall have double or reinforced insulation between the core and the surface or shall be surrounded by a metal screen having a satisfactory current-carrying capacity in the event of a short-circuit between the core and the screen.
- When installing the S200 into its operating location, it shall be ensured that any existing protective separation according to 5.2.18 of EN50178 is maintained throughout the entire length of the circuit in question. In installations the compliance for of the measures for protective separation shall be checked by visual inspection.



- Refer to Sections 1 and 4 of this manual for external fusing information.
- Motor cable shield must be connected to protective earth.
- During periods of extreme regeneration or excessively high input voltage the temperature of the regen resistor may exceed 70 °C.
- When using an external regen resistor, if regen cabling is accessible during normal machine operation, regen resistor cable should be rated at 450 VDC and shielded with shield connected to PE.
- Consult the factory before using this product on a circuit protected by a residual-current-operated protective device (RCD).
- All covers shall be closed during operation.
- The S200 drives should be used within their specified ratings.

## 12.11 EMC COMPLIANCE WITH EN61800-3

### Use in a Domestic Environment



**WARNING**

*The products covered in this manual are of the restricted sales distribution class according to IEC 61800-3. In a domestic environment this product may cause radio interference in which case the user may be required to take adequate measures.*



**CAUTION**

*Because applications differ, it is impossible for the drive manufacturer to guarantee machine EMC compliance. In some applications, it may be necessary for the machine builder to incorporate more EMC mitigation techniques than Danaher Motion had to use in the EMC test setups.*

### General Suggestions to Improve Machine EMC Performance

- Use Danaher Motion cables – Danaher Motion cables have been designed with EMC considerations in mind. Because subtle differences in cable construction can cause dramatic changes in EMC performance use of Danaher Motion's Kollmorgen motor power and feedback cables is recommended.
- When joining or splicing sections of cable, be sure to maintain the integrity of the cable shield along the entire length of the finished cable.
- Separate cables according to type - AC Mains input, motor power and signal cables should be separated from each other by at least 100 mm (4 in) to avoid cross coupling between them. If cables of different types have to cross, they should do so at a 90° angle.
- Route wiring close to machine frame - It is a good practice to run wires along the machine frame (local ground) whenever practical, this couples some high frequency noise/signals that could otherwise be troublesome directly to the local ground.
- Remove paint from all drive, filter, and cable clamp mounting locations.
- Add clamp-on ferrites to cables – Adding clamp-on ferrites to noisy cables can reduce emissions by absorbing RF energy before it is radiated.
- Use the appropriate line filter – A line filter is required for CE applications, more information on line filter selection can be found in B.10
- Add a balun to the motor power cable – adding a balun in series with the U, V and W phases of the motor power cable can attenuate both conducted and radiated emissions.
- Ensure that cables shields have a good RF ground.

## 12.12 AC MAINS CONDUCTED EMISSIONS

### Line Filter

To meet the CE-conducted EMC requirements, an external line filter (in series with the AC mains) is necessary. It is the responsibility of the machine builder to choose filter(s) appropriate for the application. Danaher Motion is willing to assist in this choice. Often, the decision is made to filter the machine as a whole instead of filtering the individual drives.

Mount the line filter as close as possible to the point where incoming power enters the machine/cabinet. Locate the drive(s) as close as possible to the line filter. To provide maximum high frequency filtering, remove any paint from between the filter, the drive and the conductive surface, ground plane to which they are bonded. For maximum benefit, separate input wiring to the line filter and output wiring from the line filter from each other.

During CE testing, three (3) line filters were qualified for use with 50 m motor and feedback cables to represent worst-case, conducted emissions compliance. The following filters were used:

Corcom 6EQ1 (single phase)

Corcom 36FCD10 (three phase)

MTE RF30006-4 (three phase)

Information on these and other filters can be found at:

#### Corcom, Inc.

USA 1-800-468-2023 *or*  
847-680-7400

Germany 49-89-857920  
<http://www.cor.com>

#### MTE Corporation

USA 1-800-455-4MTE

International 1-262-253-8200  
<http://www.mtecorp.com>



#### NOTE

**For complete instructions on wiring an AC DC version S200 drive refer to the wiring and connector descriptions of this manual.**

### Motor Power Cable Filtering

In typical applications, the S200 drives do not require additional filtering in the motor leads. Machines with many drives and long motor power cables may require an external balun in series with the power motor power cable to reduce the machine's conducted emissions. Additional information can be found in Pacific Scientific Application Notes 106 (*Reducing Motor Drive Line Noise*) and 107 (*Reducing Motor Drive Radiated Emissions*).



#### NOTE

**Balun part number is 104-090003-01.**

Current Rating	60 A sine wave pk (42 ARMS) 5 sec 20 A sine wave pk (14 ARMS) cont
Inductance	340 $\mu$ h nominal
Energy Rating	7,200 $\mu$ J nominal
Resistance	0.021 Ohm nominal
Gap	10 mil

### Ground Cable Shields

The Motor Power (J2), Feedback (J3), Command I/O (J4), and Serial Port (J5) cables must be shielded and the shields should be connected to PE. The safety PE connection can be made through connector pin or shell.



#### CAUTION

**All cables used with the S200 drives should be shielded with the shields connected to PE. Dangerous voltages, resulting from cable capacitance, exist on some cable shields if the shields are not connected to PE ground.**

## Avoid Cross talk



**To avoid the risk of cross talk, keep the motor and feedback cables away from sensitive signal cables (i.e., telephone and intercommunication lines). Shield all cables used with the S200 drives with the shields connected to PE.**

EMC testing was performed using a single drive with standard wiring. When a machine incorporates several drives or is designed for use in an environment requiring very low emissions, additional steps may be necessary to reduce the overall machine emissions and/or susceptibility. High frequency grounding of cable shields may help reduce radiated and conducted emissions as well as protect against susceptibility to external and self-generated noise.

## High Frequency Grounding of Cable Shields

- When a cable with a separate inner foil shield and outer braided shield is used, EMC performance may be improved by connecting the foil shield to the PE location on the connector and removing about 10 mm (0.5 in) of the outer cable jacket close to the drive [within 0.6 m (2 ft) of the drive] to expose the braided shield and clamping the outer braided shield to the ground plane with a 360°-type clamp.
- If a ground plane is available at the motor end of these cables, similar use of a conductive clamp at that end to connect the shield to the ground plane may help as well. Clamping the cable shields to PE typically reduces the level of emissions and increases the level of immunity to interference.



### Example of 360° clamping of cable shields



## 12.13 REGEN RESISTOR

### Regen Wiring (AC drives)

For complete instructions pertaining to an external regen resistor with an AC input drive, refer to the System Wiring Diagrams. In addition to the information in that section, users installing drives for use in a CE installation should use an appropriately-grounded, shielded regen cable to reduce overall system emissions.

### Accessible Regen Cables



**When using an external regen resistor, if regen cabling is accessible during normal machine operation, the cable should be a shielded cable rated at 450 VDC with the shield connected to PE.**

### High Frequency Grounding of Regen Cable Shield



**When using a regen resistor in a CE installation, the cable should be appropriately rated and have a braided shield connected to PE for safety, and clamped to the ground plane with a 360° clamp for EMC purposes**

## 12.14 ADDITIONAL EMC INFORMATION SOURCES

Additional information on EMC performance and noise reduction techniques can be found on the Danaher Motion website ([www.DanaherMotion.com](http://www.DanaherMotion.com)):

Kollmorgen Application Note *EMI Noise Checklist*

Pacific Scientific Application Note 106 - *Reducing Motor Drive Line Noise*

Pacific Scientific Application Note 107 - *Reducing Motor Drive Radiated Emissions*

## **Sales and Service**

We are committed to quality customer service. In order to serve in the most effective way, please contact your local sales representative for assistance.  
If you are unaware of your local sales representative, please contact us.

### **Europe**

#### **Danaher Motion Customer Support Europe**

E-Mail [support\\_dus.germany@danahermotion.com](mailto:support_dus.germany@danahermotion.com)

Internet [www.DanaherMotion.net](http://www.DanaherMotion.net)

Tel.: +49(0)203 - 99 79 - 0

Fax: +49(0)203 - 99 79 - 216

### **North America**

#### **Danaher Motion Customer Support North America**

Internet [www.DanaherMotion.com](http://www.DanaherMotion.com)

E-Mail [DMAC@danahermotion.com](mailto:DMAC@danahermotion.com)

Phone: +1 - 540 - 633 - 3400

Fax: +1 - 540 - 639 - 4162

